

MLX90215

Precision Programmable Linear Hall Effect Sensor

1. Features and Benefits

- Programmable Linear Hall IC
- Quad Switched / Chopper Stabilized
- Ratiometric Output for A/D Interface
- Adjustable Quiescent Voltage (VOQ)
- Very Low Quiescent Voltage
Temperature Drift
- Adjustable Sensitivity
- Adjustable Temperature
Compensation of Sensitivity

2. Application Examples

- Rotary position sensor
- Linear position sensor
- Current sensing

3. Ordering information

Product Code	Temperature Code	Package Code	Option Code	Packing Form Code
MLX90215	E	VA	AAA-106	BU
MLX90215	L	VA	AAA-111	BU

Legend:

Temp. Code:

E for Temperature Range: -40C to +85C

L for Temperature Range: -40C to +150C

Package Code:

VA for Plastic Single in Line Thickness 1.5mm- 1.6mm

Packing Form Code:

BU for bulk

Ordering Example:

MLX90215EVA-AAA-106-BU

Contents

1. Features and Benefits	1
2. Application Examples	1
3. Ordering information	1
4. Functional Diagram	3
5. Description.....	3
6. Electrical specifications	4
7. How does it work?	5
8. MLX90215 Performance	8
9. Melexis Programmer.....	9
10. Absolute Maximum Ratings.....	10
11. Clamping the Output Voltage.....	12
12. Application comments	12
13. Installation Comments	12
14. Physical Characteristics	13
15. Standard Information.....	14
16. ESD Precautions	14
17. Contact	14
18. Disclaimer	15

4. Functional Diagram

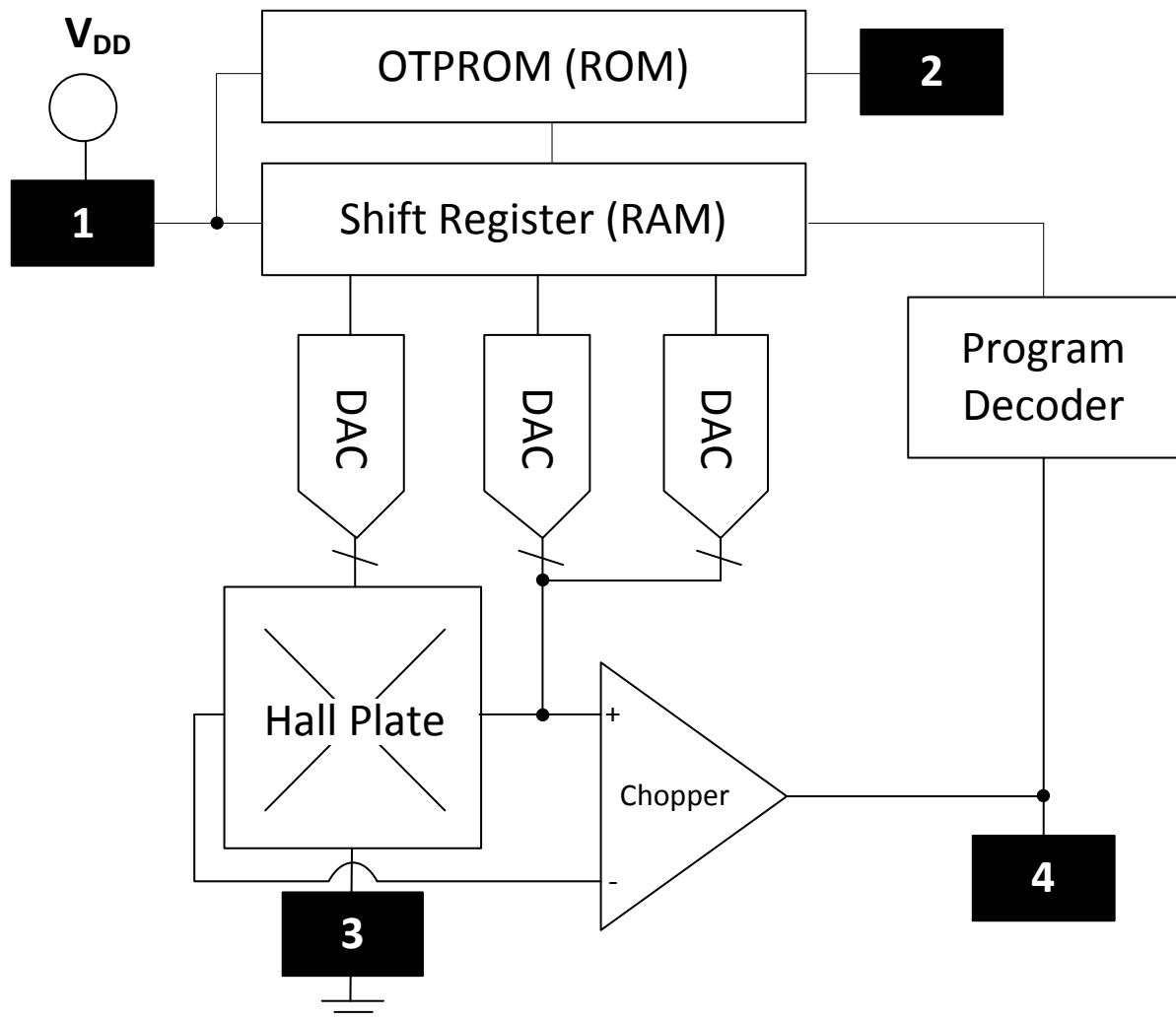

5. Description

The MLX90215 is a Programmable Linear Hall Effect sensor IC fabricated utilizing silicon-CMOS technology. It possesses active error correction circuitry which virtually eliminates the offset errors normally associated with analog Hall Effect devices. All magnetic response functions of the MLX90215 are fully programmable for even greater versatility. The VOQ ($V_{OUT@ B=0}$), sensitivity, direction of slope and the magnitude of sensitivity drift over temperature, are all programmable.

The ratiometric output voltage is proportional to the supply voltage. When using the supply voltage as a reference for an A/D converter, fluctuations of $\pm 10\%$ in supply voltage will not affect accuracy. When programmed for a conventional sensitivity (with a positive gain), the voltage at the output will increase as a South magnetic field is applied to the branded face of the MLX90215. Conversely, the voltage output will decrease in the presence of a North magnetic field. The MLX90215 has a sensitivity drift of less than +1% error, and VOQ stability drift of less than +0.4% error, over a broad temperature range.

6. Electrical specifications

DC Operating Parameters TA = -40oC to 150oC, VDD = 5.0V (Unless otherwise specified)

Parameter	Symbol	Test Conditions	Min	Typ	Max	Units
Supply Voltage	V _{DD}	Operating	4.5	5.0	5.5	V
Supply Current	I _{OUT}	B = 0, V _{DD} = 5V, I _{OUT} = 0	2.5	4.0	6.5	mA
Output Current ⁽¹⁾		V _{DD} = 5V ± 10%	-2	-	2	mA
Quiescent Output Voltage ⁽²⁾	V _{OQ}	10 – Bit Programmable, B = 0	0.5	-	4.5	V
Output Voltage ⁽¹⁾	V _{OH}	V _{DD} = 5V, I _{OUT} = -2mA	4.5	4.65		V
Output Voltage ⁽¹⁾	V _{OL}	V _{DD} = 5V, I _{OUT} = 2mA		0.35	0.50	V
Sampling Rate	f _{SAMP}	RoughGain @ Max and Min	4	-	40	kHz
Bandwidth ⁽³⁾	BW	RoughGain @ Min		-	1.300	kHz
Bandwidth ⁽³⁾	BW	RoughGain @ Max	0.130	-		kHz
Step Response Time ⁽⁶⁾	T _{RMIN}	RoughGain @ Min	25	-		µs
Step Response Time ⁽⁶⁾	T _{RMIN}	RoughGain @ Max	250			µs
Offset Voltage Adjustment Resolution	ΔV _{OQ}	B = 0, TA = 25°C, ½ V _{DD} - 1 B = 0, TA = 25°C, ½ V _{DD} = 0	-1.5 -6	-	1.5 6	mV mV
Offset Voltage Drift over Temperature	ΔV _{OQ} /ΔT	B = 0, TA = -40°C to 150°C S < 100mV/mT & V _{OQ} > 0.75V	-20	-	20	mV
Offset Voltage Drift over Temperature ⁽²⁾	ΔV _{OQ} /ΔT	B = 0, TA = -40°C to 150°C S > 100mV/mT & V _{OQ} < 0.75V	-40	-	40	mV
Range of Sensitivity ⁽⁷⁾	S	13 – Bit Programmable	5	-	140	mV/mT
Peak to Peak Noise ⁽⁴⁾			8	25	60	mV
Output Resistance	R _{OUT}			6		Ω
Sensitivity Drift ⁽⁵⁾		TA = 25°C	-1	-	1	%

Notes:

(1) If output current and voltage specifications are exceeded, linearity will be degraded.

(2) If V_{OQ} is programmed beyond these limits, the temperature compensation may become a problem at high temperatures. It is not recommended to program values of V_{OQ} below 1V or above 4V when sensitivity exceeds 100 mV/mT. Temperature instability can occur on some devices under these conditions.

(3) Bandwidth is related to the sample rate and ROUGHGAIN. Bandwidth is estimated by (sample rate / 30)

(4) Peak to Peak Noise is a function of ROUGHGAIN setting. See figure on Peak to Peak Noise versus Sensitivity.

(5) Sensitivity drift is independent of other parameters and does not include individual tolerances (V_{OQ} or V_{OQ}/T). The tolerance for sensitivity $\pm 1\%$ of its initial value. This does not include tolerance stack-up.

(6) If the step input occurs in the middle of a sample interval, the small signal response delay will double. For ROUGHGAIN values less than or equal to 3, response time may be limited by the slew rate.

(7) 1 mT = 10 Gauss

7. How does it work?

The MLX90215 programming is done through the output pin, by changing supply voltage levels. Please note that the V_{DD} is raised to approximately 13V and 18V during programming. **Any connected components must also tolerate this voltage excursion.** When the supply voltage is at 4.5V to 5.5V, the output behaves normally. If the supply voltage is raised to 13V, the output then behaves as an input, or LOAD mode, allowing the 37-bit word to be clocked in. All data is loaded through a single line, with no dedicated clock signal. Clock and data are integrated into one signal which is initiated with the beginning of the LOAD sequence, then clocked with the positive edge of each bit. Variables are changed with the PC software and loaded into the temporary register of the device (RAM) via the timings of the programmer's microcontroller. Data can be loaded as many times as desired while in LOAD mode. Once a word is loaded, results are checked by observing the output voltage. This can be done with an external Voltmeter attached directly to pin 4 of the device, or with the internal ADC of the programmer. Once the desired program is loaded, the word can be "Zapped" permanently into ROM. This is done when the supply voltage rises above 18V, or ZAP mode, creating enough current to "Zap" 31 zener diodes which correspond to the temporary register. The ZAP function is a one-time function and cannot be erased. The above description is only for reference. The voltage levels and data transfer rates are completely controlled by the ASIC programmer. For more information on the programmer hardware, contact Melexis and request a datasheet for the programmer.

Programming The Quiescent Offset Voltage (V_{OQ}) 10 bits, 1024 steps of resolution, are allotted to adjust the Quiescent Offset Voltage (V_{OQ}). By utilizing the HALFVDD function, the V_{OQ} can be set to one of two ranges. With the HALFVDD function disabled, the V_{OQ} can be programmed within a range of 10% to 90% V_{DD} with about 5mV per step resolution. With the HALFVDD function enabled, the device may be programmed within a 2V to 3V window with less than 1mV per step resolution.

Programming the Sensitivity (Gain)

The sensitivity is programmed with a ROUGHGAIN and a FINEGAIN adjustment. The ROUGHGAIN is adjusted by utilizing three bits, or 8 increments. The FINEGAIN is programmed with 10 bits or 1024 increments. The sensitivity can be programmed within a range of 5mV/mT to 140mV/mT. Another 1-bit function allows the direction of the sensitivity to be reversed. The INVERTSLOPE function, when activated, will cause the Voltage output of the MLX90215 to decrease in the presence of a South magnetic field, and to increase in the presence of a North magnetic field. Table 2 expresses examples of sensitivity resulting from programming ROUGH GAIN and FINE GAIN codes, with the INVERT SLOPE function turned off.

Note: Tables 1 and 2 are examples how various codes affect the device. Output voltage will vary slightly from device to device. Use these tables for reference only.

HalfVDD	OffsetDAC	Output	Units
0	0	4.97	V
0	512	2.47	V
0	1023	0.03	V
1	0	3.07	V
1	512	2.45	V
1	1023	1.83	V

Table 1 – Programming Offset Voltage (V_{OQ})

RougGain	FineGain	Output	Units
0	0	4.1	mV/mT
0	1023	9.4	mV/mT
1	0	6.2	mV/mT
1	1023	14.6	mV/mT
2	0	9.5	mV/mT
2	1023	22.4	mV/mT
3	0	14.2	mV/mT
3	1023	33.1	mV/mT
4	0	21.5	mV/mT
4	1023	50.4	mV/mT
5	0	31.3	mV/mT
5	1023	72.5	mV/mT
6	0	46.2	mV/mT
6	1023	107	mV/mT
7	0	68.9	mV/mT
7	1023	140	mV/mT

Table 2 – Programming Sensitivity

Temperature Compensation

Temperature compensation (TC) is defined as the change in sensitivity over temperature. Expressed in (Parts Per Million per Degree Celcius) ppm/°C.

$$TC = \frac{Sens_{T1} - Sens_{T2}}{Sens_{25}} * \frac{1}{T1 - T2} * 10^6 \frac{ppm}{^{\circ}C}$$

SensT1 = Sensitivity measured at Temperature 1 (T1)

SensT2 = Sensitivity measured at Temperature 2 (T2)

Sens25 = Initial Sensitivity measured at 25°C

Programming the Temperature Compensation

The MLX90215 has a 5-bit (32 step) programmable adjustment that changes its sensitivity drift over a given temperature range. By adjusting the TC code the sensitivity can be programmed to increase as temperature increases to counteract the decrease in magnetic flux most magnets display over temperature.

For example a SmCo (Samarium Cobalt) magnet has a temperature coefficient of approximately $-300 \text{ ppm}/^{\circ}\text{C}$. The MLX90215 can be programmed with a TC of $300 \text{ ppm}/^{\circ}\text{C}$ to counteract the TC of the magnet and greatly improve linearity in the application over temperature.

TC Code	Min	Typical	Max	Units
0	-700	-550	-350	ppm/ $^{\circ}\text{C}$
1	-625	-450	-275	ppm/ $^{\circ}\text{C}$
2	-525	-375	-175	ppm/ $^{\circ}\text{C}$
3	-450	-300	-100	ppm/ $^{\circ}\text{C}$
4	-350	-200	-25	ppm/ $^{\circ}\text{C}$
5	-275	-125	50	ppm/ $^{\circ}\text{C}$
6	-200	-50	125	ppm/ $^{\circ}\text{C}$
7	-100	25	225	ppm/ $^{\circ}\text{C}$
8	125	275	425	ppm/ $^{\circ}\text{C}$
9	225	350	525	ppm/ $^{\circ}\text{C}$
10	300	425	600	ppm/ $^{\circ}\text{C}$
11	375	525	700	ppm/ $^{\circ}\text{C}$
12	450	600	775	ppm/ $^{\circ}\text{C}$
13	525	675	850	ppm/ $^{\circ}\text{C}$
14	600	775	950	ppm/ $^{\circ}\text{C}$
15	675	850	1025	ppm/ $^{\circ}\text{C}$
16	975	1300	1550	ppm/ $^{\circ}\text{C}$
17	1025	1375	1650	ppm/ $^{\circ}\text{C}$
18	1125	1470	1750	ppm/ $^{\circ}\text{C}$
19	1200	1550	1825	ppm/ $^{\circ}\text{C}$
20	1275	1650	1950	ppm/ $^{\circ}\text{C}$
21	1325	1725	2025	ppm/ $^{\circ}\text{C}$
22	1425	1800	2125	ppm/ $^{\circ}\text{C}$
23	1475	1900	2200	ppm/ $^{\circ}\text{C}$
24	1500	2000	2125	ppm/ $^{\circ}\text{C}$
25	1550	2100	2525	ppm/ $^{\circ}\text{C}$
26	1600	2200	2625	ppm/ $^{\circ}\text{C}$
27	1675	2275	2700	ppm/ $^{\circ}\text{C}$
28	1750	2375	2825	ppm/ $^{\circ}\text{C}$
29	1825	2450	2925	ppm/ $^{\circ}\text{C}$
30	1900	2550	3025	ppm/ $^{\circ}\text{C}$
31	1950	2650	3125	ppm/ $^{\circ}\text{C}$

Table 3 – Temperature Compensation

Table 3 (left) illustrates the way the TC code affects the sensitivity temperature drift. Also note in Table 3, the overlap in TC codes. The numbers in the table represent typical results and are for reference only. For accurate results the TC code must be determined experimentally. This TC code map applies to MLX90215's with a first line brand showing "215DB"

Special Note

The MLX90215 programmed with a zero TC code (default) has a typical TC value between the range of -300 to $-600 \text{ ppm}/^{\circ}\text{C}$. This means sensitivity will decrease slightly as temperature increases. The slightly negative initial TC value allows the MLX90215 to be accurately programmed up to 0 TC. Almost all magnets have a naturally negative TC code. The natural TC of a magnet added with the initial negative TC value of the MLX90215 could degrade linearity over a large temperature span. Using a TC code of 6, 7, or 8 will give the MLX90215 a slightly positive TC code. Previous revisions of the MLX90215 with second line brand of "15AXX" or "15DXX" should refer to factory for TC code maps.

Condition	Output Level
VOUT Shorted to VDD	VOUT = VDD
VOUT Shorted to VSS	VOUT = VSS
VOUT open with pull up load	VOUT = VDD
VOUT open with pull down load	VOUT = VSS
VSS open with pull up load	VOUT = VDD
VSS open with pull down load > 10 K Ohms	VOUT = VDD or 94% VDD
VDD open with pull up load > 4.7k Ohms	VOUT = VSS or 3% VDD
VDD open with pull down load	VOUT = VSS

8. MLX90215 Performance

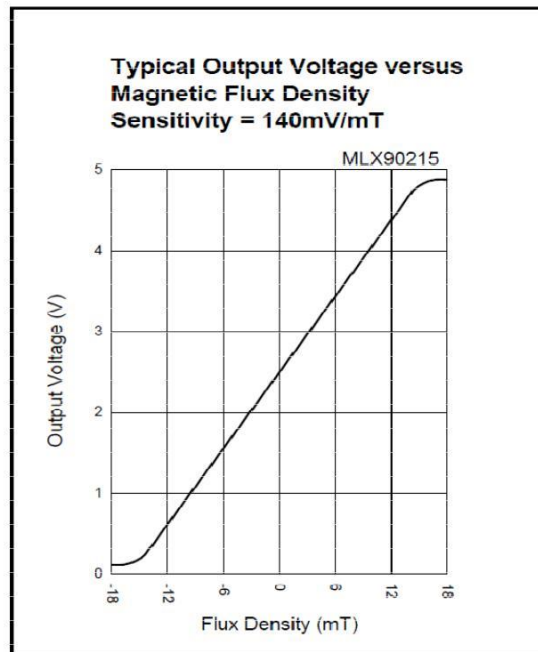
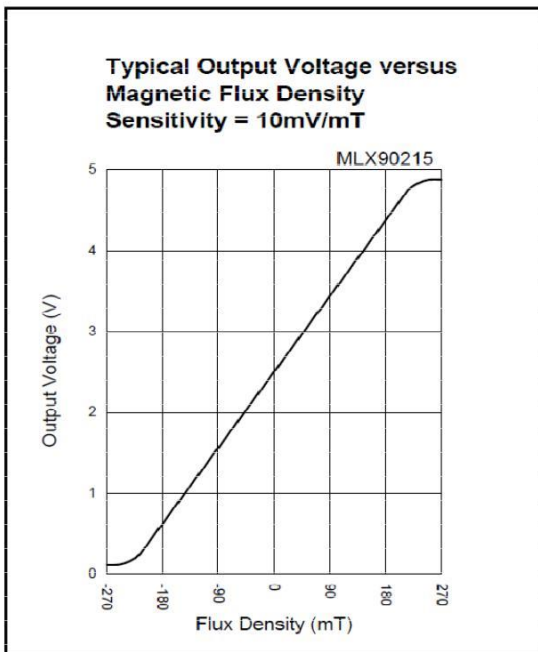
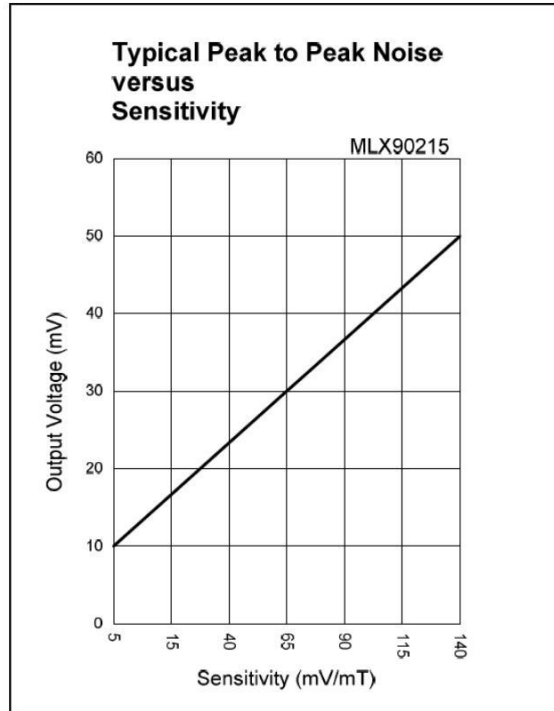
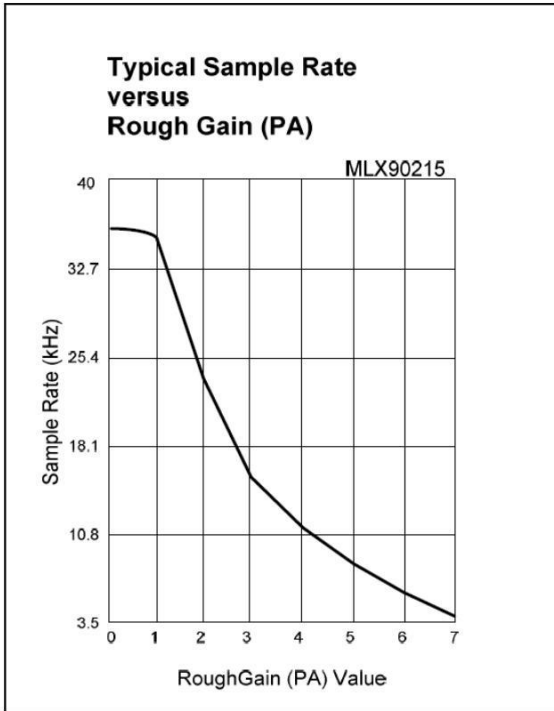

9. Melexis Programmer

Melexis offers a programmer for programming the MLX90215. The tool comes complete with windows based software that makes programming the MLX90215 simple. The programmer communicates with a PC via a RS232 serial interface. The programmer and software allows users to load settings in the MLX90215, take measurements, calibrate sensors, and program the MLX90215. For more information, please contact your sales representative.

10. Absolute Maximum Ratings

Supply Voltage (Over Voltage)	18V
Supply Voltage (Operating)	5V ± 10%
Reverse Voltage Protection	-14.5V
Magnetic Flux Density	Unlimited
Supply Current, IDD	6.5 mA
Output Current (Short to VDD)	+12 mA
Output Current (Short to VSS)	-12 mA
Operating Temperature Range, TA	-40°C to 150°C
Storage Temperature Range, TS	-55°C to 165°C
ESD Sensitivity	±5kV

Pin Description
Recommended Wiring

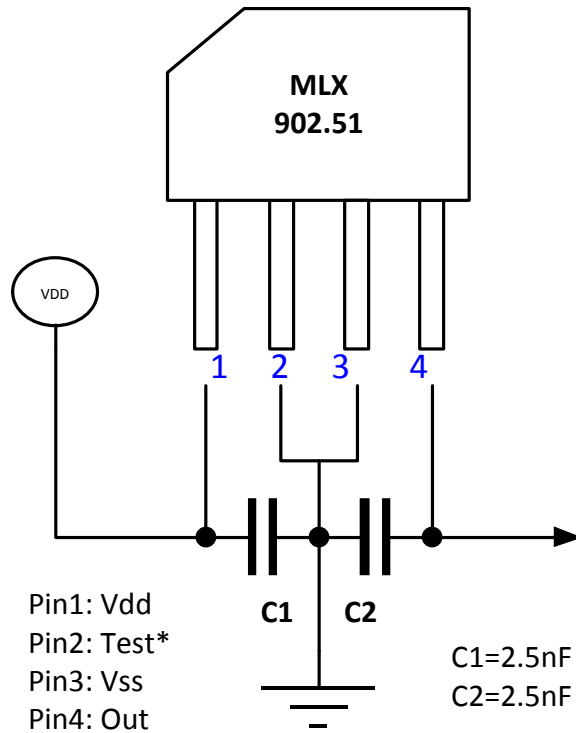

**Readback diagnostic use only. Pin2 is not for programming device. For best results tie to Vss.*

11. Clamping the Output Voltage

The MLX90215 has a 2-bit CLAMP feature which allows Four output voltage options. The CLAMP feature is independent of the gain, and will not affect sensitivity of the device. The table below illustrates limits for each of the four options.

Bit Value	Limits (% VDD)
0	(default) no clamp
1	5 to 45
2	10 to 90
3	5 to 95

12. Application comments

The following is a list of recommended operating parameters that will help to ensure the accuracy and stability of the MLX90215. These are not the absolute programming limits of the device.

- 1) Voq is best programmed in the absence of any magnetic influence and to voltages closest to 1/2 VDD, where temperature drift will be +/-0.4% or less. It is not recommended to use VOQ values close to 0 volts or VDD when programming extremely high sensitivity (> 100 mV/mT) values. Temperature instability may be observed on some devices under these conditions.
- 2) Best linearity of sensitivity is obtained when VOQ is programmed at 1/2VDD. This is with the 1/2VDD function enabled.
- 3) Best linearity of sensitivity is obtained when the gain is programmed between 5mV/mT and 100mV/mT.
- 4) Best temperature stability is realized when the temperature compensation function is programmed to zero ppm/oC.
- 5) The Test/Readback pin is for diagnostic use only. This pin is normally tied to GND. Contact Melexis for more details on programming this device.

13. Installation Comments

- 1) Avoid mechanical stress on leads or package. Stress may cause V_{OQ} shift.
 - A) Avoid bending leads at the package interface.
 - B) Support the leads by clamping, when bending.
 - C) Avoid gluing device to another material. This may cause temperature-related stress.
- 2) CMOS products are static sensitive devices, please observe ESD precautions.
- 3) Observe temperature limits during soldering

Bit	Function
1	INVERTSLOPE
2	OFFSETDAC 5
3	OFFSETDAC 6
4	OFFSETDAC 7
5	OFFSETDAC 8
6	OFFSETDAC 9
7	OFFSETDAC 4
8	OFFSETDAC 3
9	OFFSETDAC 2
10	OFFSETDAC 1
11	OFFSETDAC 0
12	FINEGAIN 0
13	FINEGAIN 1
14	FINEGAIN 2
15	HALFVDD
16	FINEGAIN 3
17	FINEGAIN 4
18	FINEGAIN 5
19	FINEGAIN 8
20	FINEGAIN 9
21	FINEGAIN 6
22	FINEGAIN 7
23	ROUGHGAIN 2
24	ROUGHGAIN 1
25	ROUGHGAIN 0
26	TEMP CO 0
27	TEMP CO 1
28	TEMP CO 2
29	TEMP CO 3
30	TEMP CO 4
31	CLAMP 1
32	CLAMP 0
33	MEMLOCK
34	TEST 0
35	TEST 1
36	TEST 2
37	TEST 3

14. Physical Characteristics

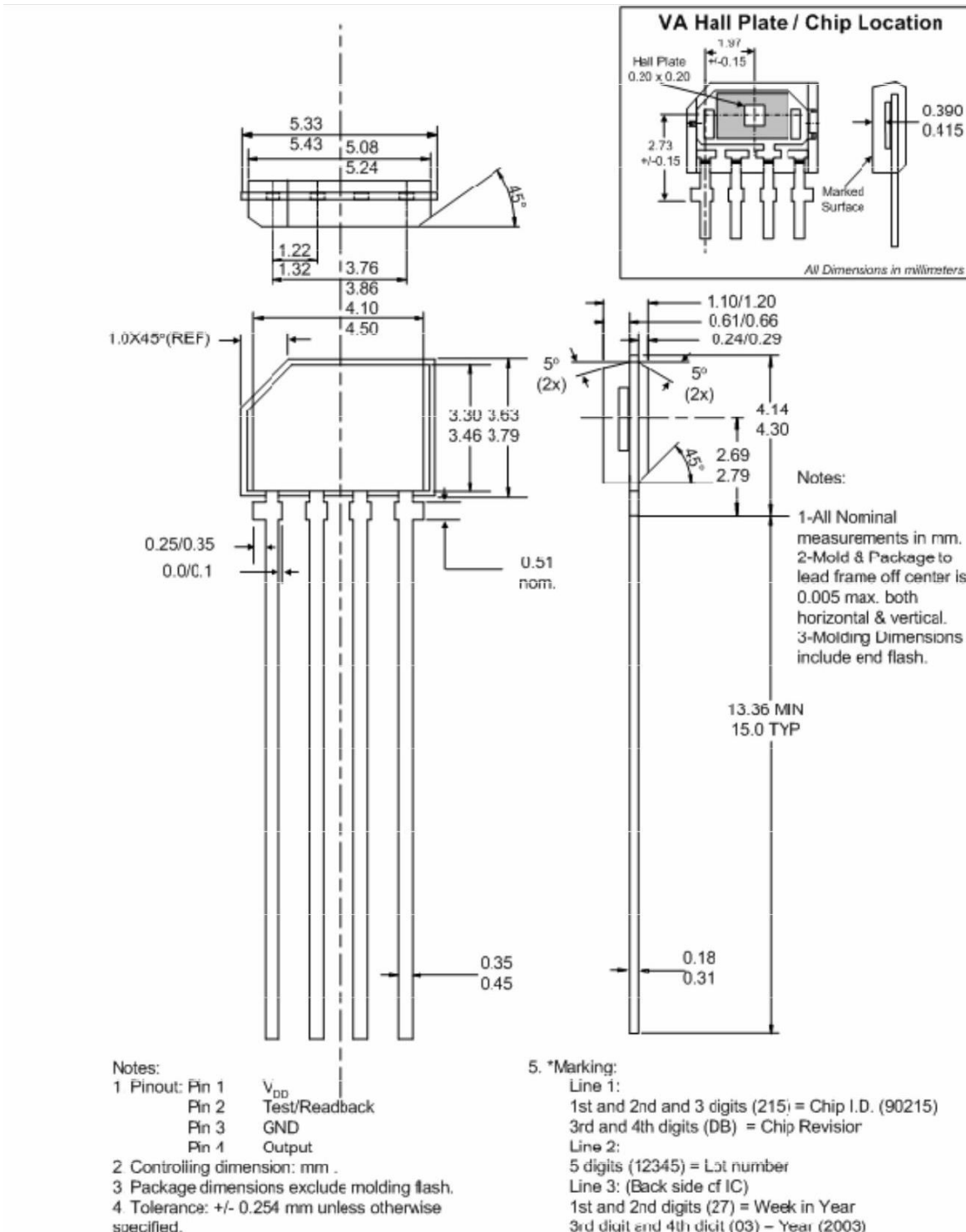

15. Standard Information

Our products are classified and qualified regarding soldering technology, solderability and moisture sensitivity level according to standards in place in Semiconductor industry.

For further details about test method references and for compliance verification of selected soldering method for product integration, Melexis recommends reviewing on our web site the General Guidelines [soldering recommendation](#). For all soldering technologies deviating from the one mentioned in above document (regarding peak temperature, temperature gradient, temperature profile etc), additional classification and qualification tests have to be agreed upon with Melexis.

For package technology embedding trim and form post-delivery capability, Melexis recommends to consult the dedicated trim&form recommendation application note: [lead trimming and forming recommendations](#)

Melexis is contributing to global environmental conservation by promoting **lead free** solutions. For more information on qualifications of **RoHS** compliant products (RoHS = European directive on the Restriction Of the use of certain Hazardous Substances) please visit the quality page on our website: <http://www.melexis.com/en/quality-environment>

16. ESD Precautions

Electronic semiconductor products are sensitive to Electro Static Discharge (ESD).

Always observe Electro Static Discharge control procedures whenever handling semiconductor products.

17. Contact

For the latest version of this document, go to our website at www.melexis.com.

For additional information, please contact our Direct Sales team and get help for your specific needs:

Europe, Africa	Telephone: +32 13 67 04 95
	Email : sales_europe@melexis.com
Americas	Telephone: +1 603 223 2362
	Email : sales_usa@melexis.com
Asia	Email : sales_asia@melexis.com

18. Disclaimer

The information furnished by Melexis herein ("Information") is believed to be correct and accurate. Melexis disclaims (i) any and all liability in connection with or arising out of the furnishing, performance or use of the technical data or use of the product(s) as described herein ("Product") (ii) any and all liability, including without limitation, special, consequential or incidental damages, and (iii) any and all warranties, express, statutory, implied, or by description, including warranties of fitness for particular purpose, non-infringement and merchantability. No obligation or liability shall arise or flow out of Melexis' rendering of technical or other services.

The Information is provided "as is" and Melexis reserves the right to change the Information at any time and without notice. Therefore, before placing orders and/or prior to designing the Product into a system, users or any third party should obtain the latest version of the relevant information to verify that the information being relied upon is current. Users or any third party must further determine the suitability of the Product for its application, including the level of reliability required and determine whether it is fit for a particular purpose.

The Information is proprietary and/or confidential information of Melexis and the use thereof or anything described by the Information does not grant, explicitly or implicitly, to any party any patent rights, licenses, or any other intellectual property rights.

This document as well as the Product(s) may be subject to export control regulations. Please be aware that export might require a prior authorization from competent authorities.

The Product(s) are intended for use in normal commercial applications. Unless otherwise agreed upon in writing, the Product(s) are not designed, authorized or warranted to be suitable in applications requiring extended temperature range and/or unusual environmental requirements. High reliability applications, such as medical life-support or life-sustaining equipment are specifically not recommended by Melexis.

The Product(s) may not be used for the following applications subject to export control regulations: the development, production, processing, operation, maintenance, storage, recognition or proliferation of 1) chemical, biological or nuclear weapons, or for the development, production, maintenance or storage of missiles for such weapons; 2) civil firearms, including spare parts or ammunition for such arms; 3) defense related products, or other material for military use or for law enforcement; 4) any applications that, alone or in combination with other goods, substances or organisms could cause serious harm to persons or goods and that can be used as a means of violence in an armed conflict or any similar violent situation.

The Products sold by Melexis are subject to the terms and conditions as specified in the Terms of Sale, which can be found at <https://www.melexis.com/en/legal/terms-and-conditions>.

This document supersedes and replaces all prior information regarding the Product(s) and/or previous versions of this document.

Melexis NV © - No part of this document may be reproduced without the prior written consent of Melexis. (2016)

ISO/TS 16949 and ISO14001 Certified

Компания «Океан Электроники» предлагает заключение долгосрочных отношений при поставках импортных электронных компонентов на взаимовыгодных условиях!

Наши преимущества:

- Поставка оригинальных импортных электронных компонентов напрямую с производств Америки, Европы и Азии, а так же с крупнейших складов мира;
- Широкая линейка поставок активных и пассивных импортных электронных компонентов (более 30 млн. наименований);
- Поставка сложных, дефицитных, либо снятых с производства позиций;
- Оперативные сроки поставки под заказ (от 5 рабочих дней);
- Экспресс доставка в любую точку России;
- Помощь Конструкторского Отдела и консультации квалифицированных инженеров;
- Техническая поддержка проекта, помощь в подборе аналогов, поставка прототипов;
- Поставка электронных компонентов под контролем ВП;
- Система менеджмента качества сертифицирована по Международному стандарту ISO 9001;
- При необходимости вся продукция военного и аэрокосмического назначения проходит испытания и сертификацию в лаборатории (по согласованию с заказчиком);
- Поставка специализированных компонентов военного и аэрокосмического уровня качества (Xilinx, Altera, Analog Devices, Intersil, Interpoint, Microsemi, Actel, Aeroflex, Peregrine, VPT, Syfer, Eurofarad, Texas Instruments, MS Kennedy, Miteq, Cobham, E2V, MA-COM, Hittite, Mini-Circuits, General Dynamics и др.);

Компания «Океан Электроники» является официальным дистрибьютором и эксклюзивным представителем в России одного из крупнейших производителей разъемов военного и аэрокосмического назначения «JONHON», а так же официальным дистрибьютором и эксклюзивным представителем в России производителя высокотехнологичных и надежных решений для передачи СВЧ сигналов «FORSTAR».



JONHON

«JONHON» (основан в 1970 г.)

Разъемы специального, военного и аэрокосмического назначения:

(Применяются в военной, авиационной, аэрокосмической, морской, железнодорожной, горно- и нефтедобывающей отраслях промышленности)

«FORSTAR» (основан в 1998 г.)

ВЧ соединители, коаксиальные кабели, кабельные сборки и микроволновые компоненты:

(Применяются в телекоммуникациях гражданского и специального назначения, в средствах связи, РЛС, а так же военной, авиационной и аэрокосмической отраслях промышленности).



Телефон: 8 (812) 309-75-97 (многоканальный)

Факс: 8 (812) 320-03-32

Электронная почта: ocean@oceanchips.ru

Web: <http://oceanchips.ru/>

Адрес: 198099, г. Санкт-Петербург, ул. Калинина, д. 2, корп. 4, лит. А