

Programmable-Current LED Lamp Driver IC with PWM Dimming

Features

- Programmable Output Current to 50mA
- PWM Dimming / Enable
- Universal 85-264VAC Operation
- Fixed OFF-Time Buck Converter
- Internal 500V Power MOSFET
- Over Temperature Protection with Hysteresis

Applications

- Decorative Lighting
- Low Power Lighting Fixtures

General Description

The HV9925 is a pulse width modulated (PWM) high-efficiency LED driver control IC with PWM dimming capabilities. It allows efficient operation of high brightness LED strings from voltage sources ranging up to 400VDC. The HV9925 includes an internal high-voltage switching MOSFET controlled with a fixed off-time T_{OFF} of approximately 10 μ s. The LED string is driven at constant current, thus providing constant light output and enhanced reliability. Selecting a value of a current sense resistor can externally program the output LED current of the HV9925. The peak current control scheme provides good regulation of the output current throughout the universal AC line voltage range of 85 to 264VAC or DC input voltage of 20 to 400V. The HV9925 is designed with a built in thermal shutdown to prevent excessive power dissipation in the IC.

Typical Application Circuit

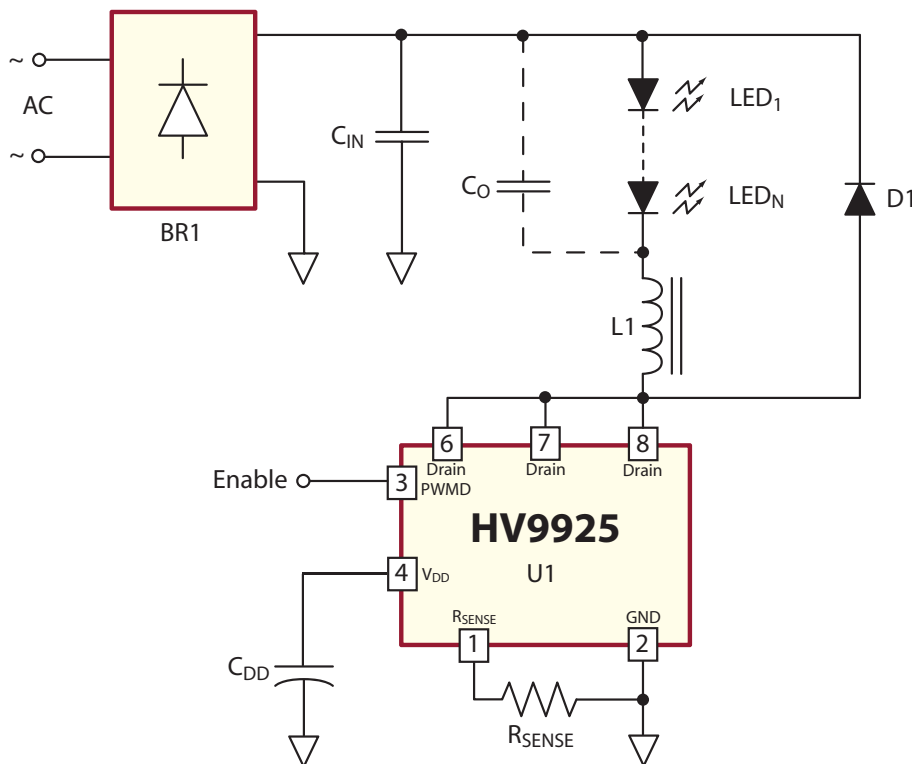

Ordering Information

DEVICE	Package Options
	8-Pin SOIC w/ Heat Slug
HV9925	HV9925SG-G

-G indicates package is RoHS compliant ('Green')



Absolute Maximum Ratings*

Parameter	Value
Supply Voltage, V_{DD}	-0.3 to +10V
PWMD, R_{SENSE} Voltage	-0.3 to +10V
Supply Current, I_{DD}	+5mA
Operating Ambient Temperature Range	-40°C to +85°C
Operating Junction Temperature Range	-40°C to +125°C
Storage Temperature Range	-65°C to +150°C
Power Dissipation @ 25°C	800mW**

All voltages referenced to GND pin.

**The power dissipation is given for the standard minimum pad without a heat slug, and based on $R_{\theta JA}=125^{\circ}C/W$. $R_{\theta JA}$ is the sum of the junction-to-case and case-to-ambient thermal resistance, where the latter is determined by the user's board design. The junction-to-ambient thermal resistance is $R_{\theta JA} = 105^{\circ}C/W$ when the part is mounted on a 0.04 in² pad of 1 oz copper, and $R_{\theta JA} = 60^{\circ}C/W$ when mounted on a 1 in² pad of 1 oz copper.

Pin Configuration

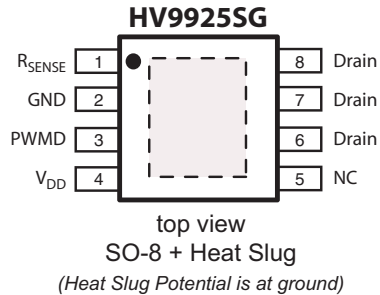

DRAIN (6,7,8) – This is a drain terminal of the output switching MOSFET and a linear regulator input.

V_{DD} (4) – This is a power supply pin for internal control circuits. Bypass this pin with a 0.1uF low impedance capacitor.

R_{SENSE} (1) – This is a source terminal of the output switching MOSFET provided for current sense resistor connection.

GND (2) – This is a common connection for all circuits.

PWMD (3) – This is the PWM Dimming input to the IC.

Electrical Characteristics

(The * denotes the specifications which apply over the full operating temperature range of $-40^{\circ}C < T_A < +85^{\circ}C$, otherwise the specifications are at $T_A = 25^{\circ}C$. $V_{DRAIN} = 100V$, unless otherwise noted)

Symbol	Parameter	Min	Typ	Max	Units	Conditions
V_{DD}	V_{DD} regulator output	-	7.5	-	V	--
V_{UVLO}	V_{DD} undervoltage threshold	5.0	-	-	V	--
ΔV_{UVLO}	V_{DD} undervoltage lockout hysteresis	-	200	-	mV	--
I_{DD}	Operating supply current	-	300	500	μA	$V_{DD(EXT)} = 8.5V$
Output (DRAIN)						
V_{BR}	Breakdown voltage	500	-	-	V	* --
V_{DRAIN}	V_{DRAIN} supply voltage	20	-	-	V	--
R_{ON}	ON resistance	-	100	200	Ω	$I_{DRAIN} = 50mA$
C_{DRAIN}	Output capacitance	-	1.0	5.0	pF	$V_{DRAIN} = 400V$
I_{SAT}	DRAIN saturation current	100	150	-	mA	--
Current Sense Comparator						
V_{TH}	Threshold voltage	0.44	0.47	0.50	V	--
T_{BLANK}	Leading edge blanking delay	200	300	400	ns	* --
$T_{ON(MIN)}$	Minimum ON time	-	-	650	ns	--

Electrical Characteristics (cont.)

Symbol	Parameter	Min	Typ	Max	Units	Conditions
OFF-Time Generator						
T_{OFF}	OFF time	8.0	10.5	13	μs	--
PWM Dimming						
$V_{PWMD,HI}$	PWMD input high voltage	2.0	-	-	V	* --
$V_{PWMD,LO}$	PWMD input low voltage	-	-	0.8	V	* --
R_{PWMD}	PWMD pull down resistance	100	200	300	$\text{k}\Omega$	$V_{PWMD} = 5\text{V}$
Thermal Shutdown						
T_{OT}	Over temperature trip limit	-	140	-	$^{\circ}\text{C}$	--
T_{HYST}	Temperature hysteresis	-	60	-	$^{\circ}\text{C}$	--

Functional Block Diagram

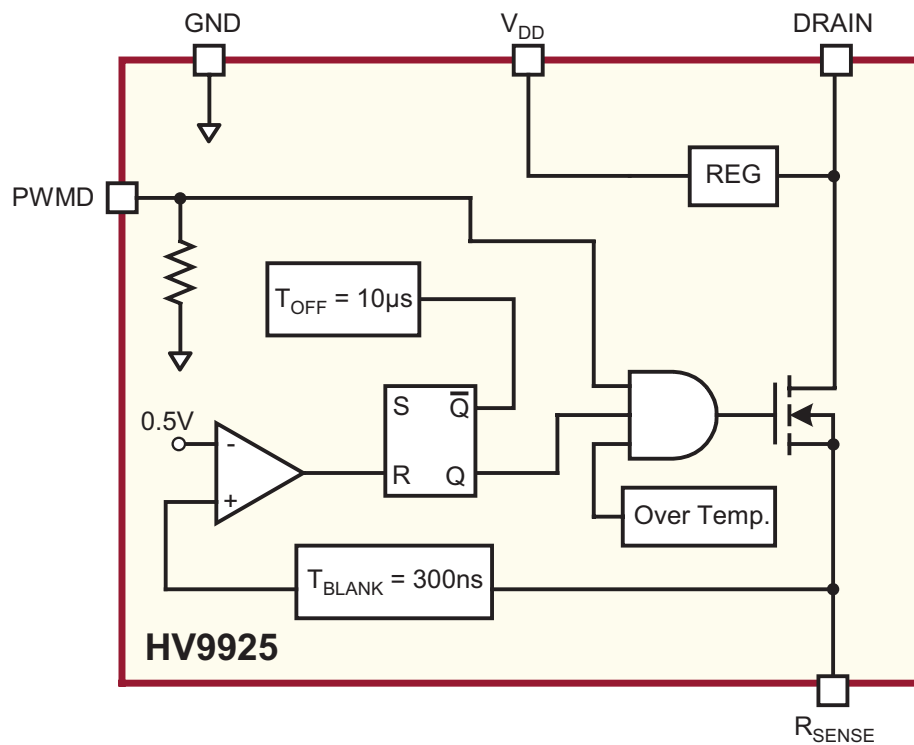

Typical Performance Characteristics ($T_J = 25^\circ\text{C}$ unless otherwise noted)

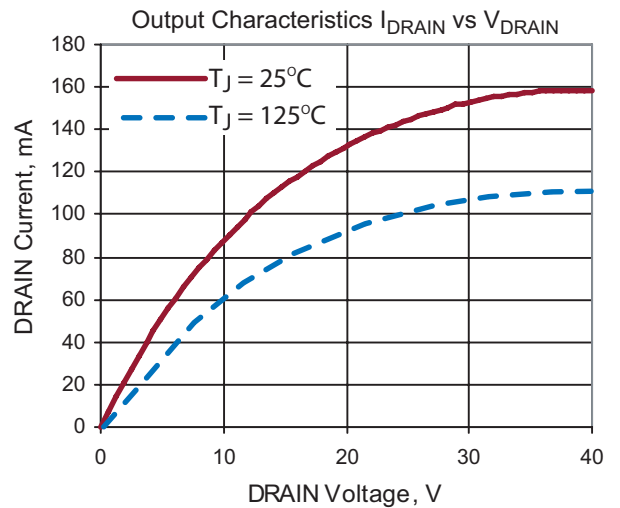
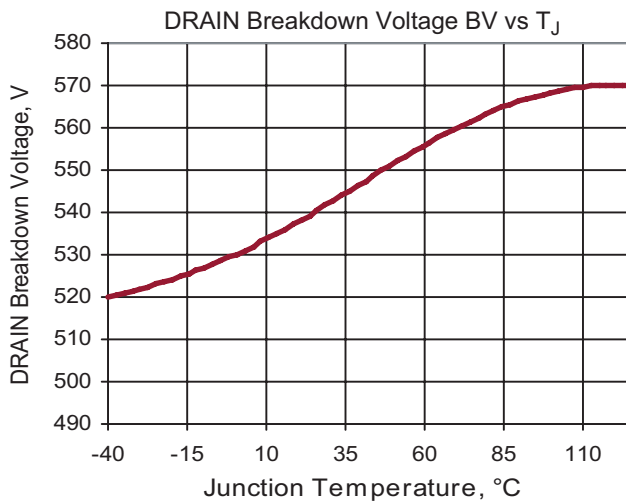
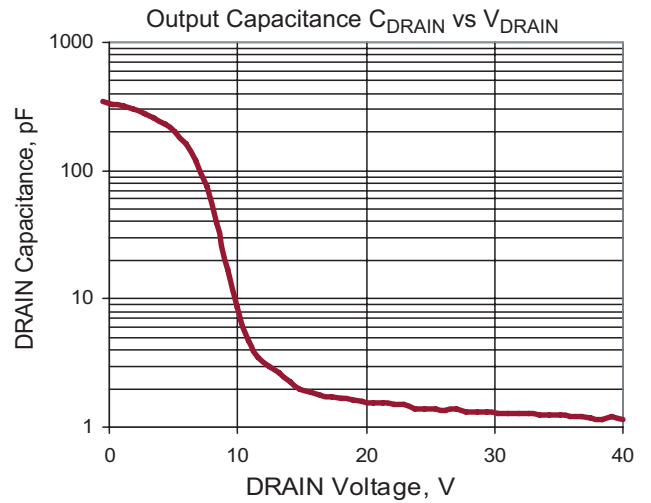
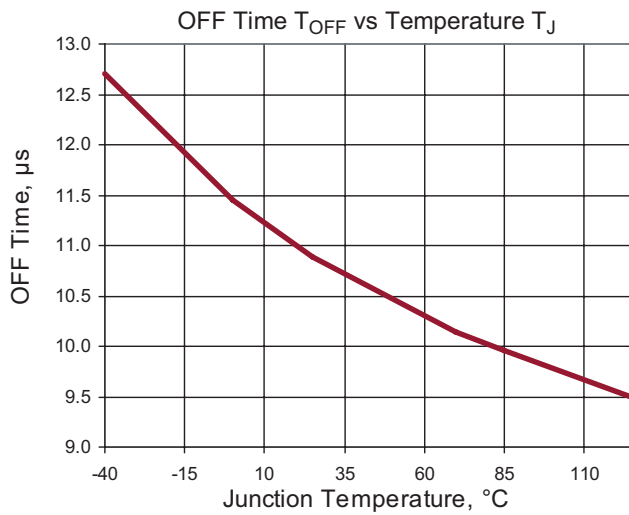
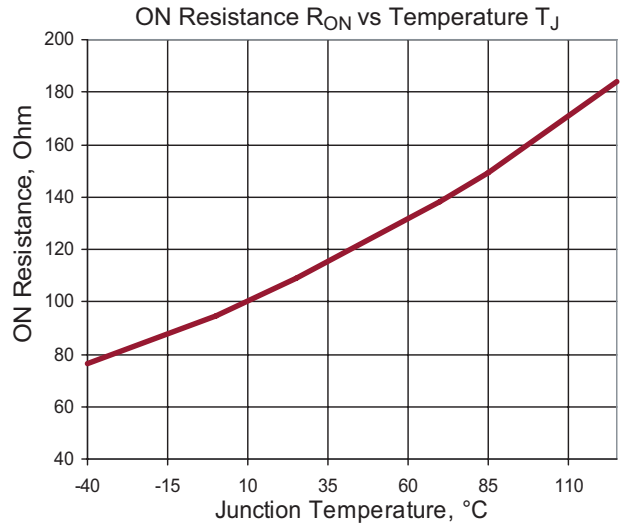
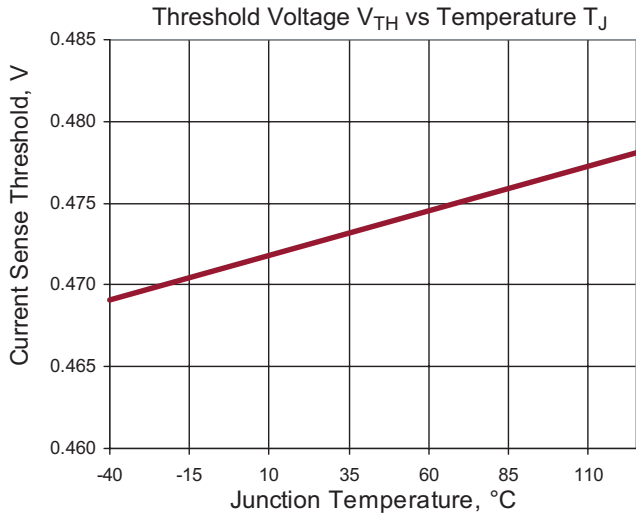

Functional Description

The HV9925 is a PWM peak current control IC for driving a buck converter topology in continuous conduction mode (CCM). The HV9925 controls the output current (rather than output voltage) of the converter that can be programmed by a single external resistor (R_{SENSE}), for the purpose of driving a string of light emitting diodes (LED). An external enable input (PWMD) is provided that can be utilized for PWM dimming of an LED string. The typical rising and falling edge transitions of the LED current when using the PWM dimming feature of the HV9925 are shown in Fig. 6 and Fig. 7.

When the input voltage of 20 to 400V appears at the DRAIN pin, the internal linear regulator seeks to maintain a voltage of 7.5VDC at the V_{DD} pin. Until this voltage exceeds the internally programmed under-voltage threshold, no output switching occurs. When the threshold is exceeded, the integrated high-voltage switch turns on, pulling the DRAIN low. A 200mV hysteresis is incorporated with the under-voltage comparator to prevent oscillation.

When the voltage at R_{SENSE} exceeds 0.47V, the switch turns off and the DRAIN output becomes high impedance. At the same time, a one-shot circuit is activated that determines the off-time of the switch (10 μ s typ.).

A “blinking” delay of 300ns is provided upon the turn-on of the switch that prevents false triggering of the current sense comparator due to the leading edge spike caused by circuit parasitics.

Application Information

Selecting L1 and D1

The required value of L1 is inversely proportional to the ripple current ΔI_O in it. Setting the relative peak-to-peak ripple to 20~30% is a good practice to ensure noise immunity of the current sense comparator.

$$L1 = \frac{V_O \cdot T_{OFF}}{\Delta I_O} \quad (1)$$

V_O is the forward voltage of the LED string. T_{OFF} is the off-time of the HV9925. The output current in the LED string (I_O) is calculated then as:

$$I_O = \frac{V_{TH}}{R_{SENSE}} - \frac{1}{2} \cdot \Delta I_O \quad (2)$$

where V_{TH} is the current sense comparator threshold, and R_{SENSE} is the current sense resistor. The ripple current introduces a peak-to-average error in the output current setting that needs to be accounted for. Due to the constant off-time control technique used in the HV9925, the ripple current is nearly independent of the input AC or DC voltage

variation. Therefore, the output current will remain unaffected by the varying input voltage.

Adding a filter capacitor across the LED string can reduce the output current ripple even further, thus permitting a reduced value of L1. However, one must keep in mind that the peak-to-average current error is affected by the variation of T_{OFF} . Therefore, the initial output current accuracy might be sacrificed at large ripple current in L1.

Another important aspect of designing an LED driver with HV9925 is related to certain parasitic elements of the circuit, including distributed coil capacitance of L1, junction capacitance, and reverse recovery of the rectifier diode D1, capacitance of the printed circuit board traces C_{PCB} and output capacitance C_{DRAIN} of the controller itself. These parasitic elements affect the efficiency of the switching converter and could potentially cause false triggering of the current sense comparator if not properly managed. Minimizing these parasitics is essential for efficient and reliable operation of HV9925.

Coil capacitance of inductors is typically provided in the manufacturer’s data books either directly or in terms of the self-resonant frequency (SRF).

$$SRF = 1/(2\pi\sqrt{L \cdot C_L})$$

where L is the inductance value, and C_L is the coil capacitance. Charging and discharging this capacitance every switching cycle causes high-current spikes in the LED string. Therefore, connecting a small capacitor C_O (~10nF) is recommended to bypass these spikes.

Using an ultra-fast rectifier diode for D1 is recommended to achieve high efficiency and reduce the risk of false triggering of the current sense comparator. Using diodes with shorter reverse recovery time t_{rr} and lower junction capacitance C_J , achieves better performance. The reverse voltage rating V_R of the diode must be greater than the maximum input voltage of the LED lamp.

The total parasitic capacitance present at the DRAIN output of the HV9925 can be calculated as:

$$C_P = C_{DRAIN} + C_{PCB} + C_L + C_J \quad (3)$$

When the switch turns on, the capacitance C_P is discharged into the DRAIN output of the IC. The discharge current is limited to about 150mA typically. However, it may become lower at increased junction temperature. The duration of the leading edge current spike can be estimated as:

$$T_{SPIKE} = \frac{V_{IN} \cdot C_P}{I_{SAT}} + t_{tr} \quad (4)$$

In order to avoid false triggering of the current sense comparator, C_p must be minimized in accordance with the following expression:

$$C_p < \frac{I_{SAT} \cdot (T_{BLANK(MIN)} - t_{tr})}{V_{IN(MAX)}} \quad (5)$$

where $T_{BLANK(MIN)}$ is the minimum blanking time of 200ns, and $V_{IN(MAX)}$ is the maximum instantaneous input voltage.

The typical DRAIN and R_{SENSE} voltage waveforms are shown in Fig. 3 and Fig. 4.

Estimating Power Loss

Discharging the parasitic capacitance C_p into the DRAIN output of the HV9925 is responsible for the bulk of the switching power loss. It can be estimated using the following equation:

$$P_{SWITCH} = \left(\frac{C_p V_{IN}^2}{2} + V_{IN} I_{SAT} \cdot t_{tr} \right) \cdot F_s \quad (6)$$

where F_s is the switching frequency and I_{SAT} is the saturated DRAIN current of the HV9925. The switching loss is the greatest at the maximum input voltage.

The switching frequency is given by the following:

$$F_s = \frac{V_{IN} - \eta^{-1} \cdot V_O}{V_{IN} \cdot T_{OFF}} \quad (7)$$

where η is the efficiency of the power converter.

When the HV9925 LED driver is powered from the full-wave rectified AC input, the switching power loss can be estimated as:

$$P_{SWITCH} \approx \frac{1}{2 \cdot T_{OFF}} (V_{AC} \cdot C_p + 2 \cdot I_{SAT} \cdot t_{tr}) (V_{AC} - \eta^{-1} \cdot V_O) \quad (8)$$

V_{AC} is the input AC line voltage.

The switching power loss associated with turn-off transitions of the DRAIN output can be disregarded. Due to the large amount of parasitic capacitance connected to this switching node, the turn-off transition occurs essentially at zero-voltage.

Conduction power loss in the HV9925 can be calculated as:

$$P_{COND} = D \cdot I_O^2 \cdot R_{ON} + I_{DD} \cdot V_{IN} \cdot (1-D) \quad (9)$$

where $D = V_O / \eta V_{IN}$ is the duty ratio, R_{ON} is the ON resistance, I_{DD} is the internal linear regulator current.

When the LED driver is powered from the full-wave

rectified AC line input, the exact equation for calculating the conduction loss is more cumbersome. However, it can be estimated using the following equation:

$$P_{COND} = K_C \cdot I_O^2 \cdot R_{ON} + K_d \cdot I_{DD} \cdot V_{AC} \quad (10)$$

where V_{AC} is the input AC line voltage. The coefficients K_C and K_d can be determined from the minimum duty ratio $D_m = 0.71 V_O / (\eta V_{AC})$.

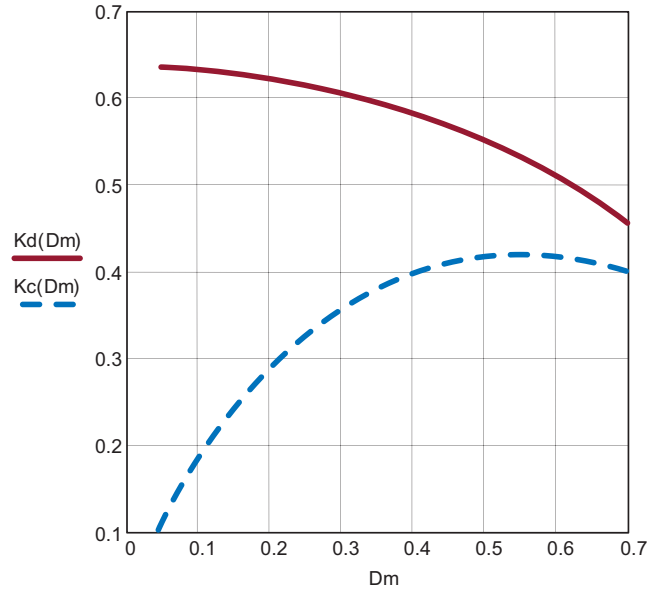

Fig. 1. Conduction Loss Coefficients K_C and K_d

EMI Filter

As with all off-line converters, selecting an input filter is critical to obtaining good EMI. A switching side capacitor, albeit of small value, is necessary in order to ensure low impedance to the high frequency switching currents of the converter. As a rule of thumb, this capacitor should be approximately 0.1-0.2 $\mu F/W$ of LED output power. A recommended input filter is shown in Figure 2 for the following design example.

Design Example 1

Let us design an HV9925 LED lamp driver meeting the following specifications:

- Input: Universal AC, 85-264VAC
- Output Current: 20mA
- Load: String of 10 LED (LW541C by OSRAM
 $V_F = 4.1V$ max. each)

The schematic diagram of the LED driver is shown in Fig.2.

Step 1. Calculating L1.

The output voltage $V_O = 10 \cdot V_F \approx 41V$ (max.). Use equation (1) assuming a 30% peak-to-peak ripple.

$$L1 = \frac{41V \cdot 10\mu s}{0.3 \cdot 20mA} = 68mH$$

Select L1 68mH, I=30mA. Typical SRF = 170KHz. Calculate the coil capacitance.

$$C_L = \frac{1}{L1 \cdot (2\pi \cdot SRF)^2} = \frac{1}{68mH \cdot (2\pi \cdot 170KHz)^2} \approx 13pF$$

Step 2. Selecting D1

Usually, the reverse recovery characteristics of ultra-fast rectifiers at $I_F = 20\sim 50mA$ are not provided in the manufacturer's data books. The designer may want to experiment with different diodes to achieve the best result.

Select D1 MUR160 with $V_R = 600V$, $t_{rr} \approx 20ns$ ($I_F = 20mA$, $I_{RR} = 100mA$) and $C_j \approx 8pF$ ($V_F > 50V$).

Step 3. Calculating total parasitic capacitance using:

$$C_p = 5pF + 5pF + 13pF + 8pF = 31pF \quad (3)$$

Step 4. Calculating the leading edge spike duration using: (4), (5)

$$T_{SPIKE} = \frac{264V \cdot \sqrt{2} \cdot 31pF}{100mA} + 20ns \approx 136ns < T_{BLANK(MIN)}$$

Step 5. Estimating power dissipation in HV9925 at 264VAC using (8) and (10)

Let us assume that the overall efficiency $\eta = 0.7$.

Switching power loss:

$$P_{SWITCH} \approx \frac{1}{2 \cdot 10\mu s} (264V \cdot 31pF + 2 \cdot 100mA \cdot 20ns) \left(264V - \frac{41V}{0.7} \right)$$

$$P_{SWITCH} \approx 125mW$$

Minimum duty ratio:

$$D_m = 0.71 \cdot 41V / (0.7 \cdot 264V) \approx 0.16$$

Conduction power loss:

$$P_{COND} = 0.25 \cdot (20mA)^2 \cdot 210\Omega + 0.63 \cdot 200\mu A \cdot 264V \approx 55mW$$

Total power dissipation at $V_{AC(max)}$:

$$P_{TOTAL} = 125mW + 55mW = 180mW$$

Step 6. Selecting input capacitor C_{IN}

$$\text{Output Power} = 41V \cdot 20mA = 820mW$$

Select C_{IN} ECQ-E4104KF by Panasonic (0.1 μ F, 400V, Metalized Polyester Film).

Design Example 2

Let us now design a PWM-dimmable LED lamp driver using the HV9925:

Input: Universal AC, 85-135VAC

Output Current: 50mA

Load: String of 12 LED (Power TOPLED[®] by OSRAM, $V_F = 2.5V$ max. each)

The schematic diagram of the LED driver is shown in Fig.3. We will use an aluminum electrolytic capacitor for C_{IN} in order to prevent interruptions of the LED current at zero crossings of the input voltage. As a "rule of thumb", 2~3 μ F per each watt of the input power is required for C_{IN} in this case.

Step 1. Calculating L1.

The output voltage $V_O = 12 \cdot V_F = 30V$ (max.). Use equation (1) assuming a 30% peak-to-peak ripple.

$$L1 = \frac{30V \cdot 10.5\mu s}{0.3 \cdot 50mA} = 21mH$$

Select L1 22mH, I = 60mA. Typical SRF = 270KHz. Calculate the coil capacitance.

$$C_L = \frac{1}{L1 \cdot (2\pi \cdot SRF)^2} = \frac{1}{22mH \cdot (2\pi \cdot 270KHz)^2} \approx 15pF$$

Step 2. Selecting D1

Select D1 ES1G with $V_R = 400V$, $t_{rr} \approx 35ns$ and $C_j < 10pF$.

Step 3. Calculating total parasitic capacitance using: (3)

$$C_p = 5pF + 5pF + 13pF + 8pF = 31pF$$

Step 4. Calculating the leading edge spike duration using (4), (5)

$$T_{SPIKE} = \frac{135V \cdot \sqrt{2} \cdot 35pF}{100mA} + 35ns \approx 100ns < T_{BLANK(MIN)}$$

Step 5. Estimating power dissipation in HV9925 at 135VAC using (6), (7) and (9)

Switching power loss:

$$F_s = \frac{135V \cdot \sqrt{2} - 30V / 0.7}{135V \cdot \sqrt{2} \cdot 10\mu s} = 78kHz$$

$$P_{\text{SWITCH}} = \left(35\text{pF} \cdot (135\text{V})^2 + 135\text{V} \cdot \sqrt{2} \cdot 100\text{mA} \cdot 35\text{ns} \right) \cdot 78\text{kHz}$$

$$P_{\text{SWITCH}} \approx 52\text{mW}$$

Minimum duty ratio:

$$D_m = 30\text{V} / (0.7 \cdot 135\text{V} \cdot \sqrt{2}) \approx 0.23$$

Conduction power loss:

$$P_{\text{COND}} = \frac{30\text{V} \cdot (50\text{mA})^2 \cdot 200\Omega}{0.7 \cdot 85\text{V} \cdot \sqrt{2}} + 0.5\text{mA} \cdot \left(85\text{V} \cdot \sqrt{2} - \frac{30\text{V}}{0.7} \right)$$

$$P_{\text{COND}} = 217\text{mW}$$

Total power dissipation in HV9925:

$$P_{\text{TOTAL}} = 52\text{mW} + 217\text{mW} = 269\text{mW}$$

Step 6. Selecting input capacitor C_{IN}

$$\text{Output Power} = 30\text{V} \cdot 50\text{mA} = 1.5\text{W}$$

Select C_{IN} 3.3 μF , 250V.

Figure 2. Universal 85-264VAC LED Lamp Driver

($I_o = 20\text{mA}$, $V_o = 50\text{V}$) from Example 1

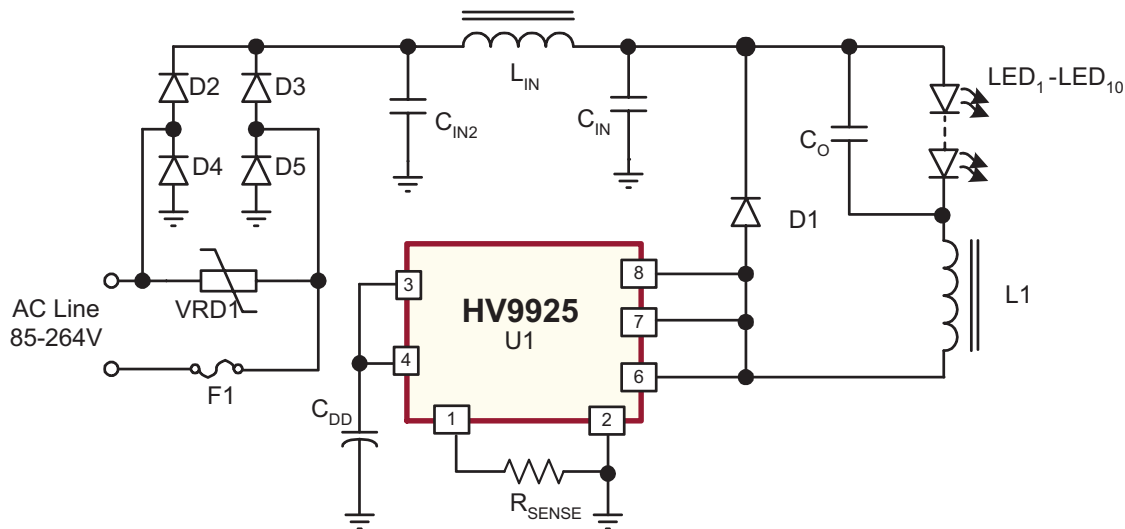

Figure 3. 85-135VAC LED Lamp Driver with PWM Dimming

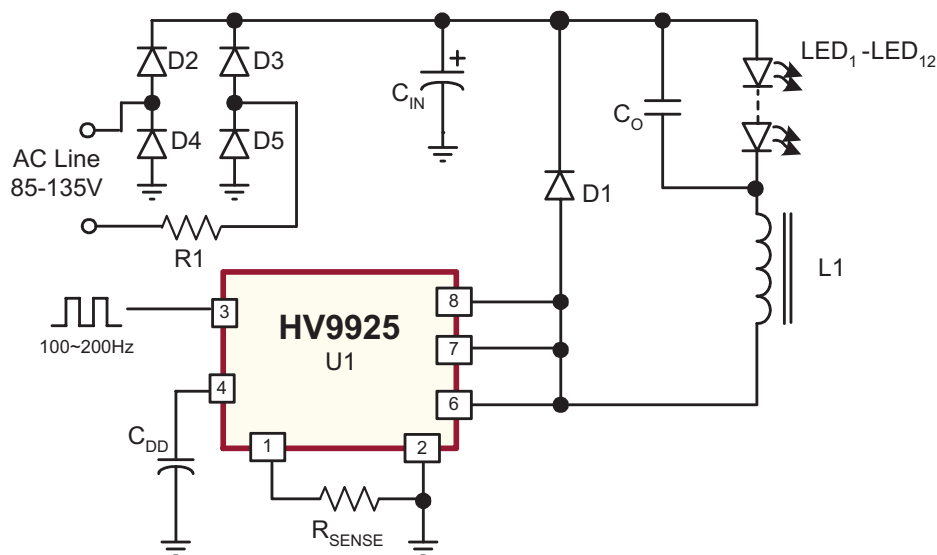

Figure 4. Switching Waveforms. CH1: V_{RSENSE} , CH2: V_{DRAIN}

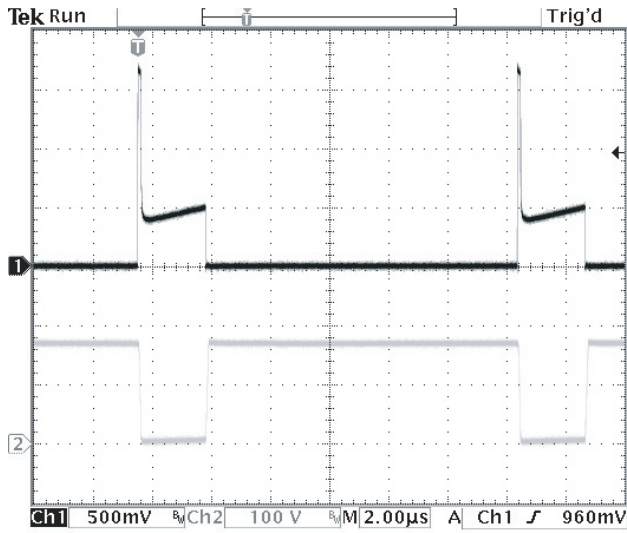

Figure 5. Switch-On Transition – Leading Edge Spike. CH1: V_{RSENSE} , CH2: V_{DRAIN}

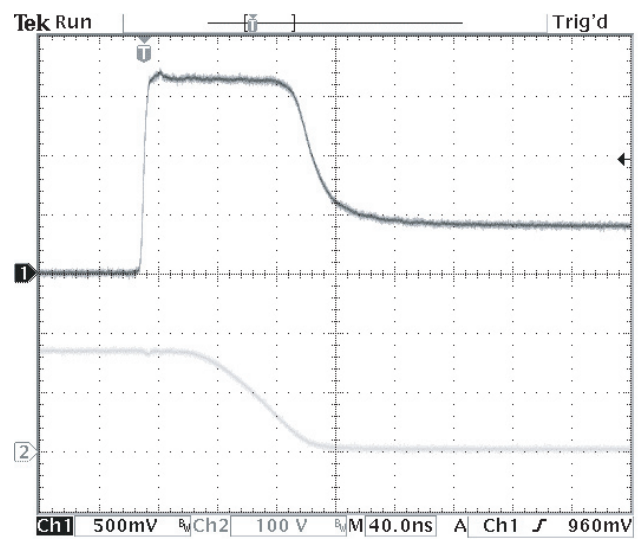

Figure 6. PWM Dimming – Rising Edge. CH4: $10 \times I_{OUT}$

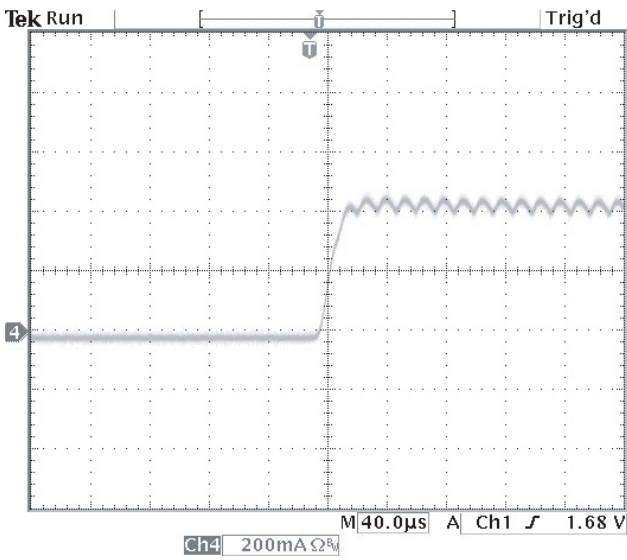
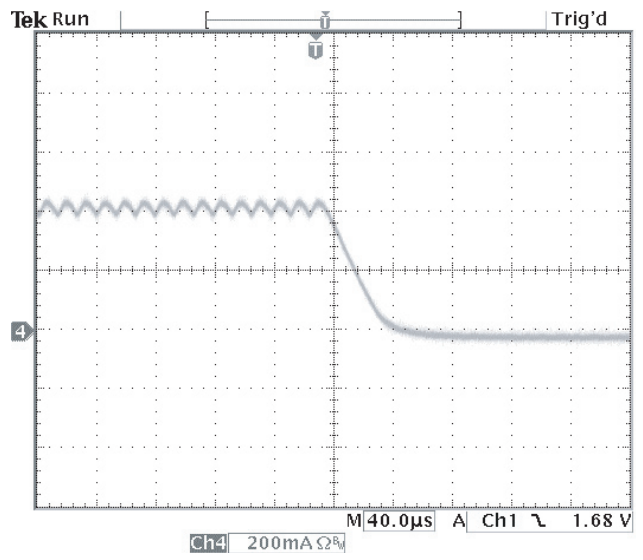
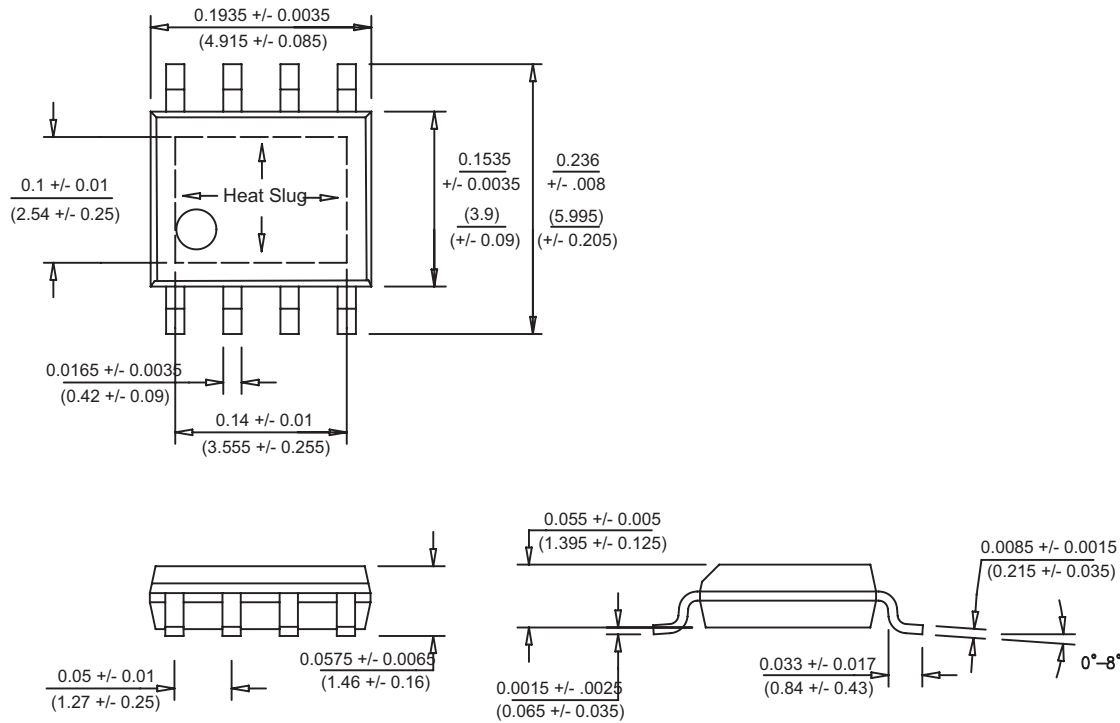

Figure 7. PWM Dimming – Falling Edge. CH4: $10 \times I_{OUT}$



8-LEAD SMALL OUTLINE PACKAGE WITH HEAT SLUG (SG)



Measurement Legend = $\frac{\text{Dimensions in Inches}}{\text{(Dimensions in Millimeters)}}$

Supertex inc. does not recommend the use of its products in life support applications, and will not knowingly sell its products for use in such applications, unless it receives an adequate "product liability indemnification insurance agreement". **Supertex** does not assume responsibility for use of devices described and limits its liability to the replacement of the devices determined defective due to workmanship. No responsibility is assumed for possible omissions or inaccuracies. Circuitry and specifications are subject to change without notice. For the latest product specifications, refer to the **Supertex** website: <http://www.supertex.com>.

©2006 **Supertex inc.** All rights reserved. Unauthorized use or reproduction is prohibited.

Supertex inc.
1235 Bordeaux Drive, Sunnyvale, CA 94089
TEL: (408) 222-8888 / FAX: (408) 222-4895
www.supertex.com

Компания «Океан Электроники» предлагает заключение долгосрочных отношений при поставках импортных электронных компонентов на взаимовыгодных условиях!

Наши преимущества:

- Поставка оригинальных импортных электронных компонентов напрямую с производств Америки, Европы и Азии, а так же с крупнейших складов мира;
- Широкая линейка поставок активных и пассивных импортных электронных компонентов (более 30 млн. наименований);
- Поставка сложных, дефицитных, либо снятых с производства позиций;
- Оперативные сроки поставки под заказ (от 5 рабочих дней);
- Экспресс доставка в любую точку России;
- Помощь Конструкторского Отдела и консультации квалифицированных инженеров;
- Техническая поддержка проекта, помощь в подборе аналогов, поставка прототипов;
- Поставка электронных компонентов под контролем ВП;
- Система менеджмента качества сертифицирована по Международному стандарту ISO 9001;
- При необходимости вся продукция военного и аэрокосмического назначения проходит испытания и сертификацию в лаборатории (по согласованию с заказчиком);
- Поставка специализированных компонентов военного и аэрокосмического уровня качества (Xilinx, Altera, Analog Devices, Intersil, Interpoint, Microsemi, Actel, Aeroflex, Peregrine, VPT, Syfer, Eurofarad, Texas Instruments, MS Kennedy, Miteq, Cobham, E2V, MA-COM, Hittite, Mini-Circuits, General Dynamics и др.);

Компания «Океан Электроники» является официальным дистрибьютором и эксклюзивным представителем в России одного из крупнейших производителей разъемов военного и аэрокосмического назначения «JONHON», а так же официальным дистрибьютором и эксклюзивным представителем в России производителя высокотехнологичных и надежных решений для передачи СВЧ сигналов «FORSTAR».



JONHON

«JONHON» (основан в 1970 г.)

Разъемы специального, военного и аэрокосмического назначения:

(Применяются в военной, авиационной, аэрокосмической, морской, железнодорожной, горно- и нефтедобывающей отраслях промышленности)

«FORSTAR» (основан в 1998 г.)

ВЧ соединители, коаксиальные кабели, кабельные сборки и микроволновые компоненты:

(Применяются в телекоммуникациях гражданского и специального назначения, в средствах связи, РЛС, а так же военной, авиационной и аэрокосмической отраслях промышленности).



Телефон: 8 (812) 309-75-97 (многоканальный)

Факс: 8 (812) 320-03-32

Электронная почта: ocean@oceanchips.ru

Web: <http://oceanchips.ru/>

Адрес: 198099, г. Санкт-Петербург, ул. Калинина, д. 2, корп. 4, лит. А