

MAXIM **$\pm 15\text{kV}$ ESD-Protected, 460kbps, $1\mu\text{A}$, RS-232-Compatible Transceiver****General Description**

The MAX3314E is a $\pm 5\text{V}$ -powered EIA/TIA-232-compatible interface. It has one transmitter and one receiver in a flow-through architecture. The transmitter output and the receiver input are protected to $\pm 15\text{kV}$ using IEC 1000-4-2 Air-Gap Discharge, $\pm 8\text{kV}$ using IEC 1000-4-2 Contact Discharge, and $\pm 15\text{kV}$ using the Human Body Model.

The transmitter has a low-dropout output stage providing minimum RS-232-compatible $\pm 3.7\text{V}$ output levels while driving $3\text{k}\Omega$ and 1000pF at 460kbps. Both $+5\text{V}$ and -5V must be supplied externally.

The MAX3314E has a $\overline{\text{SHDN}}$ function that reduces supply current to $1\mu\text{A}$. The transmitter is disabled and put into tristate while the receiver remains active.

The MAX3314E is available in 8-pin μMAX , SOT23, and SO packages.

Applications

Digital Cameras
PDA's
GPS
POS
Telecommunications
Handy-Terminals
Set-Top Boxes

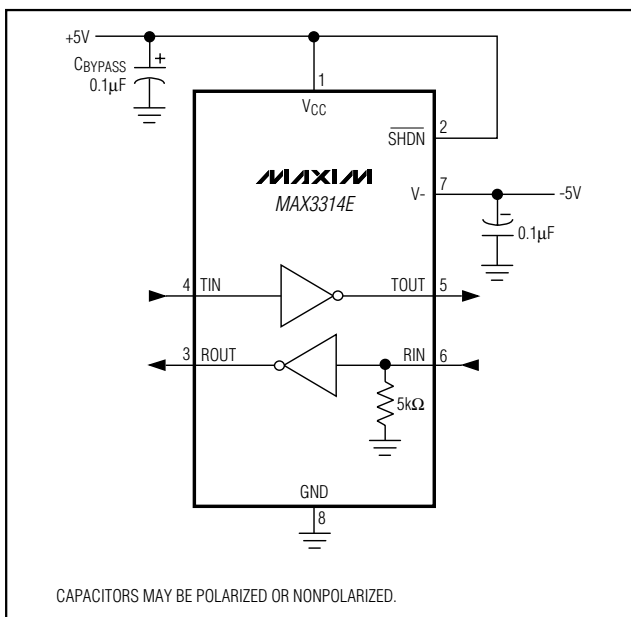
Typical Operating Circuit**Features**

- ◆ ESD Protection for RS-232 I/O Pins
 - $\pm 15\text{kV}$ —Human Body Model
 - $\pm 8\text{kV}$ —IEC 1000-4-2 Contact Discharge
 - $\pm 15\text{kV}$ —IEC 1000-4-2 Air-Gap Discharge
- ◆ $1\mu\text{A}$ Low-Power Shutdown with Receiver Active
- ◆ $30\mu\text{A}$ Operating Supply Current
- ◆ 460kbps Guaranteed Data Rate
- ◆ 8-Pin SOT23 Package
- ◆ $\pm 3.7\text{V}$ RS-232-Compatible Levels

Ordering Information

PART	TEMP. RANGE	PIN-PACKAGE
MAX3314ECKA-T	0°C to +70°C	8 SOT23-8
MAX3314ECUA	0°C to +70°C	8 μMAX
MAX3314ECSA	0°C to +70°C	8 SO
MAX3314EEKA-T	-40°C to +85°C	8 SOT23-8
MAX3314EEUA	-40°C to +85°C	8 μMAX
MAX3314EESA	-40°C to +85°C	8 SO

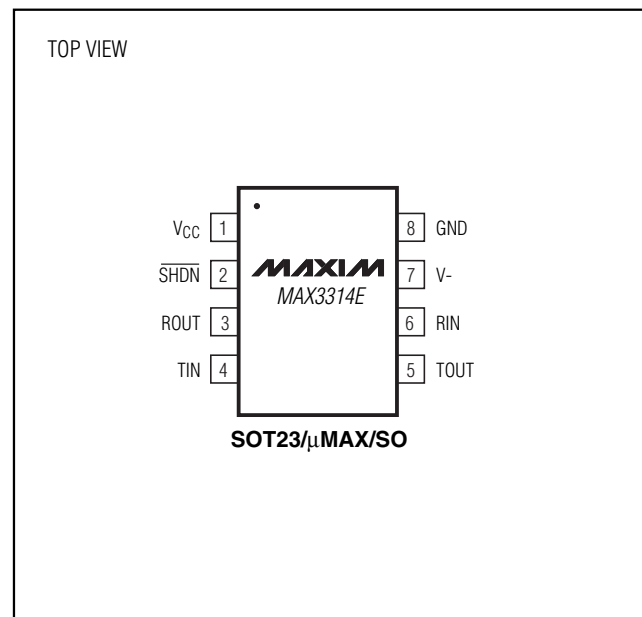
Pin Configuration**MAXIM**

Maxim Integrated Products 1

For pricing, delivery, and ordering information, please contact Maxim/Dallas Direct! at 1-888-629-4642, or visit Maxim's website at www.maxim-ic.com.

MAX3314E

±15kV ESD-Protected, 460kbps, 1μA, RS-232-Compatible Transceiver

ABSOLUTE MAXIMUM RATINGS

V _{CC} to GND	-0.3V to +6V	Continuous Power Dissipation	
V ₋ to GND	+0.3V to -6V	8-Pin SOT23 (derate 9.7mW/°C above +70°C).....	777mW
Input Voltages		8-Pin μMAX (derate 4.1mW/°C above +70°C).....	300mW
T _{IN} , $\overline{\text{SHDN}}$ to GND	-0.3V to +6V	8-Pin SO (derate 5.88mW/°C above +70°C).....	471mW
R _{IN} to GND	±25V	Operating Temperature Ranges	
Output Voltages		MAX3314EC_A	0°C to +70°C
T _{OUT} to GND.....	±13.2V	MAX3314EE_A.....	-40°C to +85°C
R _{OUT}	-0.3V to (V _{CC} + 0.3V)	Junction Temperature.....	+150°C
Short-Circuit Duration		Storage Temperature Range	-65°C to +150°C
T _{OUT} to GND	Continuous	Lead Temperature (soldering, 10s)	+300°C

Stresses beyond those listed under "Absolute Maximum Ratings" may cause permanent damage to the device. These are stress ratings only, and functional operation of the device at these or any other conditions beyond those indicated in the operational sections of the specifications is not implied. Exposure to absolute maximum rating conditions for extended periods may affect device reliability.

ELECTRICAL CHARACTERISTICS

(V_{CC} = +5V, V₋ = -5V, T_A = T_{MIN} to T_{MAX}. Typical values are at T_A = +25°C.)

PARAMETER	SYMBOL	CONDITIONS	MIN	TYP	MAX	UNITS
DC CHARACTERISTICS						
Positive Supply Operating Range	V _{CC}		4.75	5	5.25	V
Negative Supply Operating Range	V ₋		-4.75	-5	-5.25	V
Positive Supply Current		$\overline{\text{SHDN}} = V_{CC}$, no load		30	100	μA
Negative Supply Current		$\overline{\text{SHDN}} = V_{CC}$, no load		15	30	μA
Shutdown Supply Current		$\overline{\text{SHDN}} = \text{GND}$		1	10	μA
LOGIC INPUTS (T_{IN}, $\overline{\text{SHDN}}$)						
Input Logic Threshold Low	V _{IL}		0.8			V
Input Logic Threshold High	V _{IH}				2.4	V
Transmitter Input Hysteresis				0.5		V
Input Leakage Current				±0.01		μA
RECEIVER OUTPUT						
Output Voltage Low	V _{OL}	I _{OUT} = 1.6mA			0.4	V
Output Voltage High	V _{OH}	I _{OUT} = -1.0mA	V _{CC} -0.3	V _{CC} -0.1		V
RECEIVER INPUT						
Input Threshold Low	V _{IL}		0.8			V
Input Threshold High	V _{IH}				2.4	V
Input Hysteresis				0.5		V
Input Resistance				5		kΩ
TRANSMITTER OUTPUT						
Output Voltage Swing		Transmitter output loaded with 3kΩ to ground	±3.7			V
Output Resistance (Note 1)		V _{CC} = V ₋ = 0, transmitter output = ±2V	300			Ω
Output Short-Circuit Current					±60	mA
Output Leakage Current		V _{OUT} = ±12V, transmitter disabled			25	μA
ESD PROTECTION (Transmitter Output, Receiver Input)						
ESD-Protection Voltage		Human Body Model	±15		kV	
		IEC 1000-4-2 Air-Gap Discharge	±15			
		IEC 1000-4-2 Contact Discharge	±8			

±15kV ESD-Protected, 460kbps, 1μA, RS-232-Compatible Transceiver

MAX3314E

TIMING CHARACTERISTICS

(V_{CC} = +5V, V₋ = -5V, T_A = T_{MIN} to T_{MAX}. Typical values are at T_A = +25°C.)

PARAMETER	SYMBOL	CONDITIONS	MIN	TYP	MAX	UNITS
Maximum Data Rate		R _L = 3kΩ, C _L = 1000pF, transmitter switching	460			kbps
Receiver Propagation Delay	t _{PLH}	Receiver input to receiver output, C _L = 150pF		0.15		μs
	t _{PHL}	Receiver input to receiver output, C _L = 150pF		0.15		
Transmitter Skew				100		ns
Receiver Skew				50		ns
Transition Region Slew Rate		R _L = 3kΩ to 7kΩ, C _L = 150pF to 1000pF, measured from +3V to -3V or -3V to +3V		8		V/μs

Note 1: Not tested, guaranteed by design.

Typical Operating Characteristics

(V_{CC} = +5V, V₋ = -5V, 250kbps data rate, transmitter loaded with 3kΩ and C_L, T_A = +25°C, unless otherwise noted.)

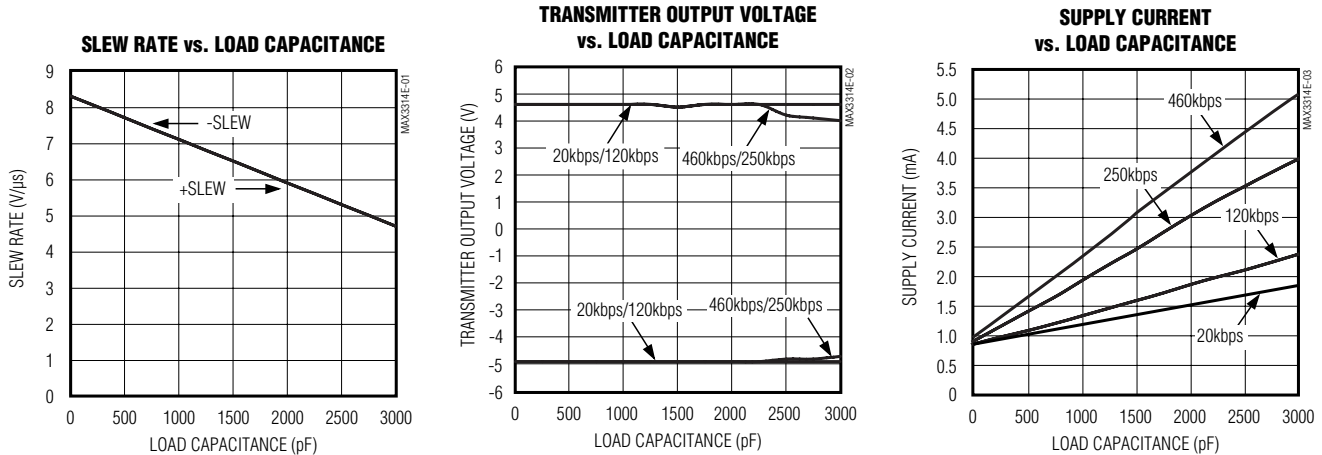

±15kV ESD-Protected, 460kbps, 1μA, RS-232-Compatible Transceiver

Pin Description

PIN	NAME	FUNCTION
1	V _{CC}	+5V ±5% External Power Supply. Decouple with a 0.1μF capacitor to ground.
2	$\overline{\text{SHDN}}$	Shutdown, Active low (0 = off, 1 = on).
3	ROUT	TTL/CMOS Receiver Output
4	TIN	TTL/CMOS Transmitter Input
5	TOUT	RS-232-Compatible Transmitter Output
6	RIN	RS-232-Compatible Receiver Input
7	V-	-5V ±5% External Power Supply. Decouple with a 0.1μF capacitor to ground.
8	GND	Ground

Detailed Description

RS-232-Compatible Drivers

The transmitter is an inverting level translator that converts CMOS-logic levels to ±3.7V EIA/TIA-232-compatible levels. It guarantees data rates up to 460kbps with worst-case loads of 3kΩ in parallel with 1000pF. When $\overline{\text{SHDN}}$ is driven low, the transmitter is disabled and put into tristate. The transmitter input does not have a pull-up resistor. Connect to ground if unused.

RS-232-Compatible Receivers

The MAX3314E's receiver converts RS-232 signals to CMOS-logic output levels. The receiver is rated to receive signals to ±25V. It will remain active during shutdown mode.

MAX3314E Shutdown Mode

In shutdown mode, the transmitter output is put into high impedance (Table 1). This reduces supply current to 1μA. The time required to exit shutdown is less than 2.5μs.

Applications Information

Capacitor Selection

The capacitor type used is not critical for proper operation; either polarized or nonpolarized capacitors are acceptable. If polarized capacitors are used, connect polarity as shown in the *Typical Operating Circuit*.

Bypass V_{CC} and V- to ground with at least 0.1μF.

Transmitter Outputs When Exiting Shutdown

Figure 1 shows the transmitter output when exiting shutdown mode. The transmitter is loaded with 3kΩ in

parallel with 1000pF. The transmitter output displays no ringing or undesirable transients as the MAX3314E comes out of shutdown.

High Data Rates

The MAX3314E maintains minimum RS-232-compatible ±3.7V transmitter output voltage even at high data rates. Figure 2 shows a transmitter loopback test circuit. Figure 3 shows the loopback test result at 120kbps, and Figure 4 shows the same test at 250kbps.

±15kV ESD Protection

As with all Maxim devices, ESD-protection structures are incorporated on all pins to protect against electrostatic discharges encountered during handling and assembly. The MAX3314E driver outputs and receiver inputs have extra protection against static discharge. Maxim's engineers have developed state-of-the-art structures to protect these pins against ESD of ±15kV without damage. The ESD structures withstand high ESD in all states: normal operation, shutdown, and powered down. After an ESD event, Maxim's E versions keep working without latchup, whereas competing products can latch and must be powered down to remove latchup.

ESD protection can be tested in various ways. The transmitter outputs and receiver inputs of the product family are characterized for protection to the following limits:

- ±15kV using the Human Body Model
- ±8kV using the Contact Discharge method specified in IEC 1000-4-2
- ±15kV using the IEC 1000-4-2 Air-Gap method

$\pm 15\text{kV}$ ESD-Protected, 460kbps, $1\mu\text{A}$, RS-232-Compatible Transceiver

MAX3314E

Table 1. Shutdown Logic Truth Table

$\overline{\text{SHDN}}$	TRANSMITTER OUTPUT	RECEIVER OUTPUT
L	High Z	Active
H	Active	Active

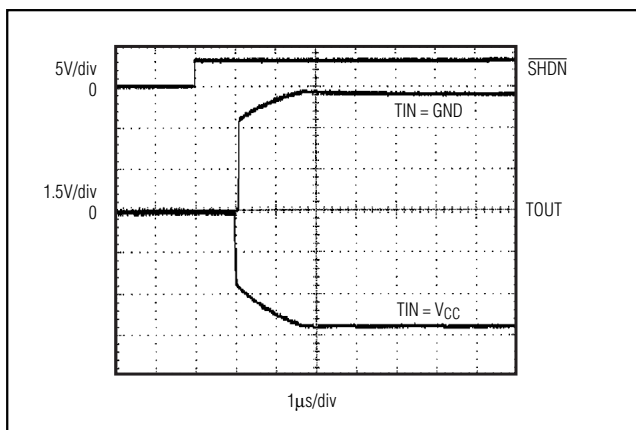

Figure 1. Transmitter Outputs When Exiting Shutdown or Powering Up

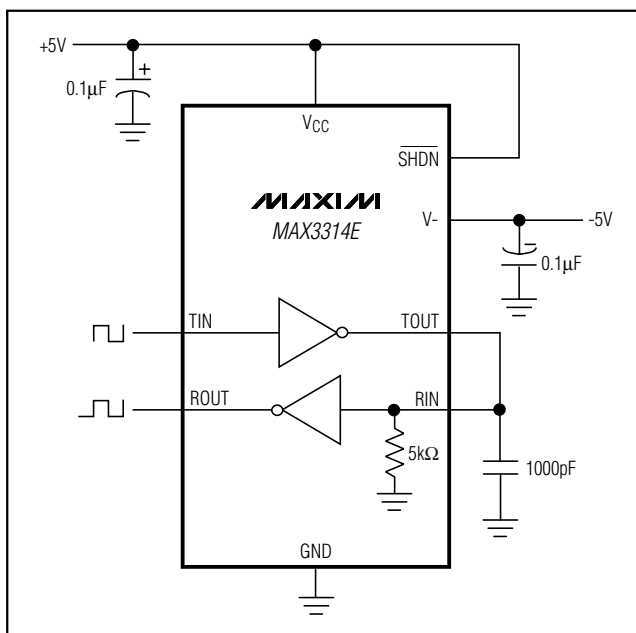

Figure 2. Loopback Test Circuit

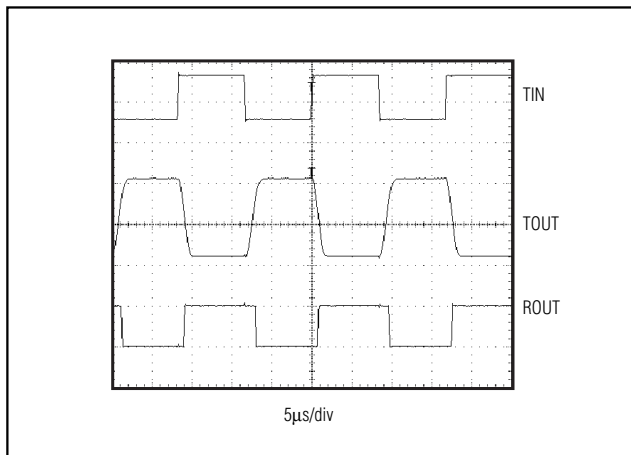

Figure 3. Loopback Test Result at 120kbps

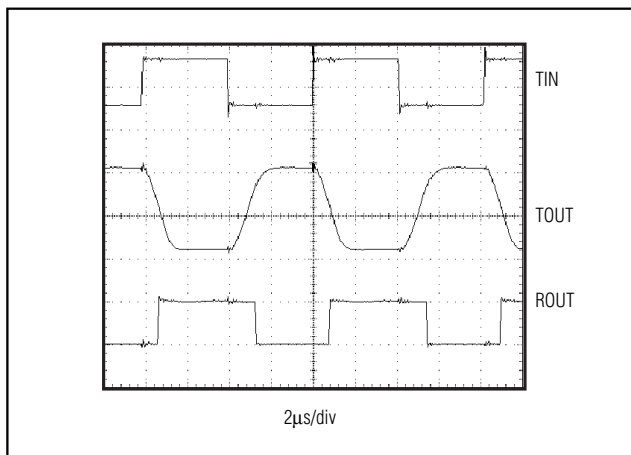

Figure 4. Loopback Test Result at 250kbps

ESD Test Conditions

ESD performance depends on a variety of conditions. Contact Maxim for a reliability report that documents test setup, test methodology, and test results.

Human Body Model

Figure 5 shows the Human Body Model, and Figure 6 shows the current waveform it generates when discharged into low impedance. This model consists of a 100pF capacitor charged to the ESD voltage of interest, which is then discharged into the test device through a 1.5kΩ resistor.

±15kV ESD-Protected, 460kbps, 1μA, RS-232-Compatible Transceiver

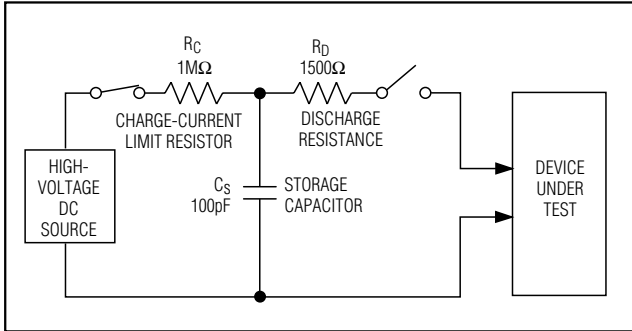

Figure 5. Human Body ESD Test Model

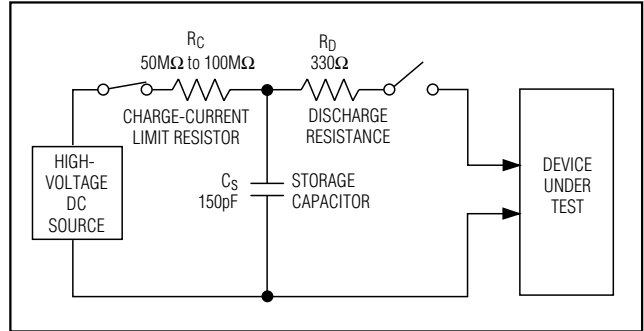

Figure 7. IEC 1000-4-2 ESD Test Model

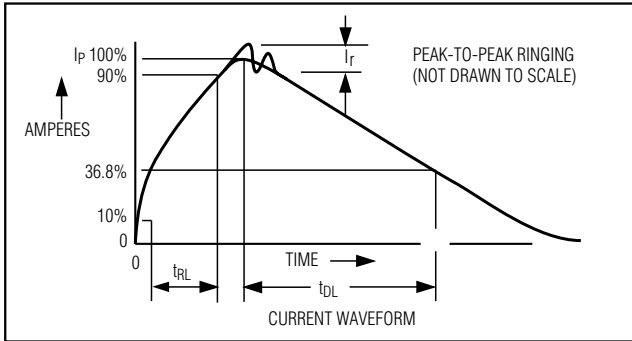

Figure 6. Human Body Current Waveform

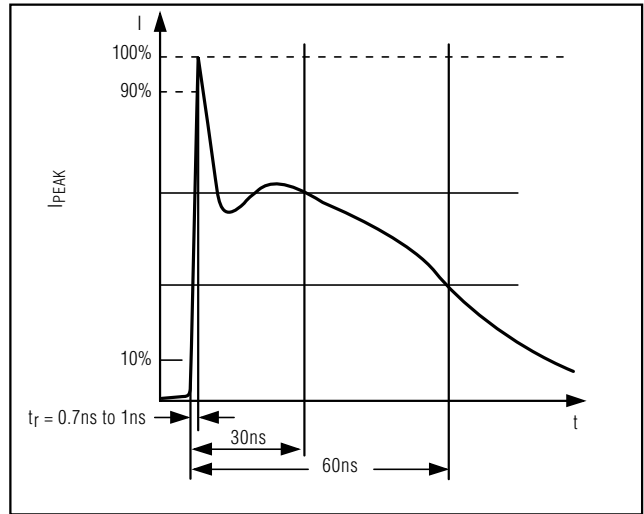

Figure 8. IEC 1000-4-2 ESD Generator Current Waveform

IEC 1000-4-2

The IEC 1000-4-2 standard covers ESD testing and performance of finished equipment; it does not specifically refer to ICs. The MAX3314E helps design equipment that meets Level 4 (the highest level) of IEC 1000-4-2 without the need for additional ESD-protection components.

The major difference between tests done using the Human Body Model and IEC 1000-4-2 is higher peak current in IEC 1000-4-2 because series resistance is lower in the IEC 1000-4-2 model. Hence, the ESD withstand voltage measured to IEC 1000-4-2 is generally lower than that measured using the Human Body Model. Figure 7 shows the IEC 1000-4-2 model, and Figure 8 shows the current waveform for the 8kV, IEC 1000-4-2, Level 4, ESD Contact Discharge test.

The Air-Gap test involves approaching the device with a charged probe. The Contact Discharge method connects the probe to the device before the probe is energized.

Machine Model

The Machine Model for ESD tests all pins using a 200pF storage capacitor and zero discharge resistance. Its objective is to emulate the stress caused by

contact that occurs with handling and assembly during manufacturing. Of course, all pins require this protection during manufacturing, not just RS-232 inputs and outputs. Therefore, after PC board assembly, the Machine Model is less relevant to I/O ports.

Chip Information

TRANSISTOR COUNT: 128

±15kV ESD-Protected, 460kbps, 1µA, RS-232-Compatible Transceiver

Package Information

MAX3314E

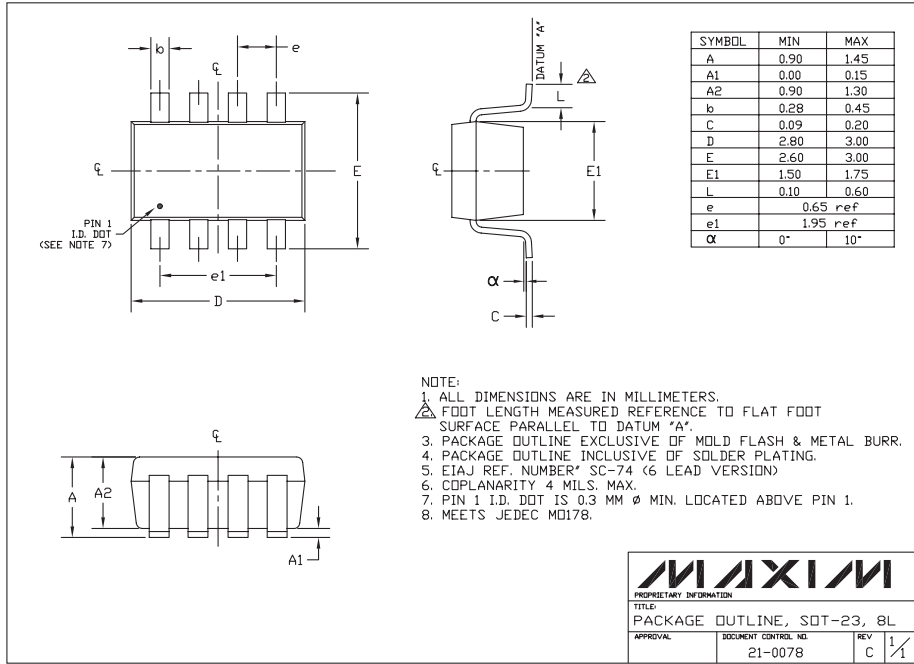

SOT23, 8LEPS

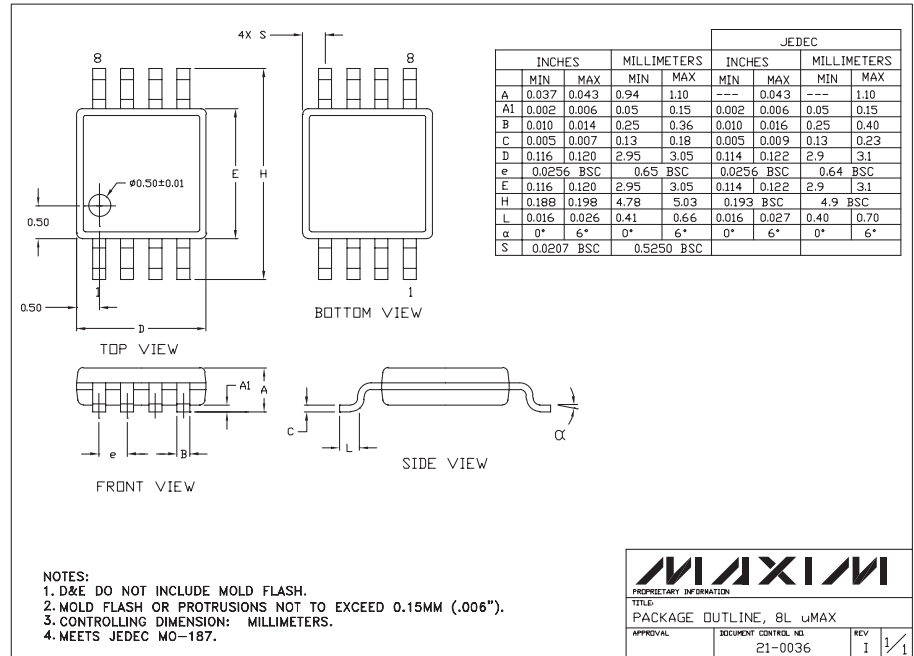

8LUMAXDEPS

±15kV ESD-Protected, 460kbps, 1µA, RS-232-Compatible Transceiver

Package Information (continued)

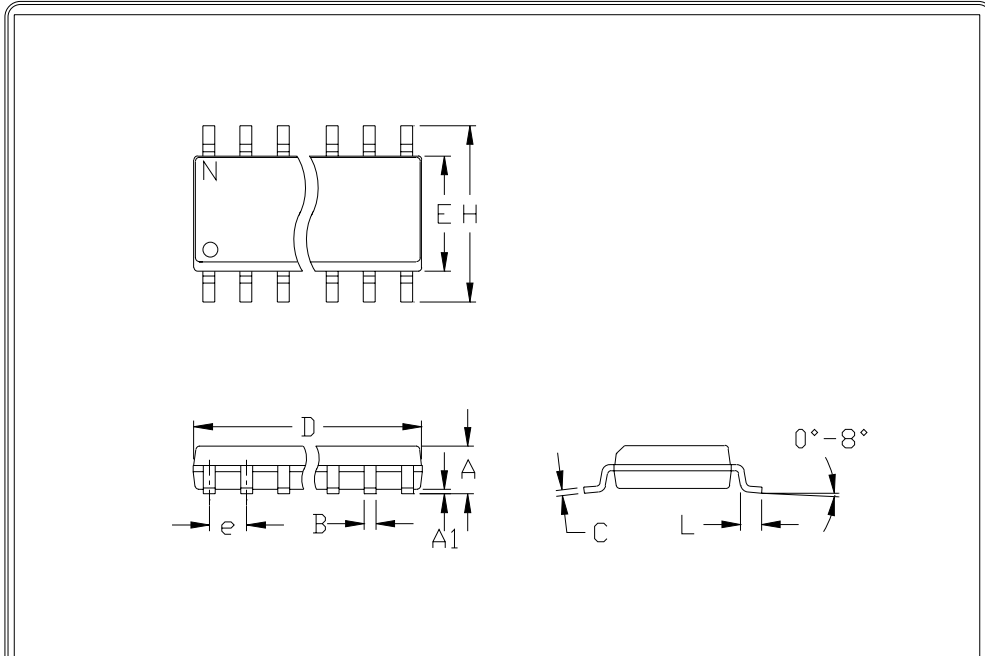

SOICNERS

	INCHES		MILLIMETERS	
	MIN	MAX	MIN	MAX
A	0.053	0.069	1.35	1.75
A1	0.004	0.010	0.10	0.25
B	0.014	0.019	0.35	0.49
C	0.007	0.010	0.19	0.25
e	0.050		1.27	
E	0.150	0.157	3.80	4.00
H	0.228	0.244	5.80	6.20
h	0.010	0.020	0.25	0.50
L	0.016	0.050	0.40	1.27

	INCHES		MILLIMETERS		N	MS012
	MIN	MAX	MIN	MAX		
D	0.189	0.197	4.80	5.00	8	A
D	0.337	0.344	8.55	8.75	14	B
D	0.386	0.394	9.80	10.00	16	C

- NOTES:
1. D&E DO NOT INCLUDE MOLD FLASH
 2. MOLD FLASH OR PROTRUSIONS NOT TO EXCEED .15mm (.006")
 3. LEADS TO BE COPLANAR WITHIN .102mm (.004")
 4. CONTROLLING DIMENSION: MILLIMETER
 5. MEETS JEDEC MS012-XX AS SHOWN IN ABOVE TABLE
 6. N = NUMBER OF PINS

 <small>120 SAN GABRIEL DR. SUNNYVALE CA 94086 FAX (408) 737-7194</small> <small>PROPRIETARY INFORMATION</small>	PACKAGE FAMILY OUTLINE: SOIC .150"		21-0041 A

Maxim cannot assume responsibility for use of any circuitry other than circuitry entirely embodied in a Maxim product. No circuit patent licenses are implied. Maxim reserves the right to change the circuitry and specifications without notice at any time.

8 **Maxim Integrated Products, 120 San Gabriel Drive, Sunnyvale, CA 94086 408-737-7600**

Компания «Океан Электроники» предлагает заключение долгосрочных отношений при поставках импортных электронных компонентов на взаимовыгодных условиях!

Наши преимущества:

- Поставка оригинальных импортных электронных компонентов напрямую с производств Америки, Европы и Азии, а так же с крупнейших складов мира;
- Широкая линейка поставок активных и пассивных импортных электронных компонентов (более 30 млн. наименований);
- Поставка сложных, дефицитных, либо снятых с производства позиций;
- Оперативные сроки поставки под заказ (от 5 рабочих дней);
- Экспресс доставка в любую точку России;
- Помощь Конструкторского Отдела и консультации квалифицированных инженеров;
- Техническая поддержка проекта, помощь в подборе аналогов, поставка прототипов;
- Поставка электронных компонентов под контролем ВП;
- Система менеджмента качества сертифицирована по Международному стандарту ISO 9001;
- При необходимости вся продукция военного и аэрокосмического назначения проходит испытания и сертификацию в лаборатории (по согласованию с заказчиком);
- Поставка специализированных компонентов военного и аэрокосмического уровня качества (Xilinx, Altera, Analog Devices, Intersil, Interpoint, Microsemi, Actel, Aeroflex, Peregrine, VPT, Syfer, Eurofarad, Texas Instruments, MS Kennedy, Miteq, Cobham, E2V, MA-COM, Hittite, Mini-Circuits, General Dynamics и др.);

Компания «Океан Электроники» является официальным дистрибьютором и эксклюзивным представителем в России одного из крупнейших производителей разъемов военного и аэрокосмического назначения «**JONHON**», а так же официальным дистрибьютором и эксклюзивным представителем в России производителя высокотехнологичных и надежных решений для передачи СВЧ сигналов «**FORSTAR**».



JONHON

«**JONHON**» (основан в 1970 г.)

Разъемы специального, военного и аэрокосмического назначения:

(Применяются в военной, авиационной, аэрокосмической, морской, железнодорожной, горно- и нефтедобывающей отраслях промышленности)

«**FORSTAR**» (основан в 1998 г.)

ВЧ соединители, коаксиальные кабели,
кабельные сборки и микроволновые компоненты:

(Применяются в телекоммуникациях гражданского и специального назначения, в средствах связи, РЛС, а так же военной, авиационной и аэрокосмической отраслях промышленности).



Телефон: 8 (812) 309-75-97 (многоканальный)

Факс: 8 (812) 320-03-32

Электронная почта: ocean@oceanchips.ru

Web: <http://oceanchips.ru/>

Адрес: 198099, г. Санкт-Петербург, ул. Калинина, д. 2, корп. 4, лит. А