

LTC3886/LTC3870

60V Dual Output Step-Down DC/DC Controller with Digital Power System Management

DESCRIPTION

Demonstration circuit 2155A is available in two configurations. The DC2155A-A is a dual output synchronous step-down converter featuring the [LTC®3886](#), a dual-phase current mode controller. The DC2155A-B is a single output synchronous step-down converter that operates with four phases: two from the LTC3886 and two from LTC3870, a phase extender. Both versions have a PMBus interface and digital power system management functions.

The DC2155A uses discrete MOSFETs in the power stage. The input range of this board is from 18V to 54V. The output voltage can be programmed from 5V to 12V with an output current of up to 12A per phase. For the DC2155A-A version, the factory default setting for the CH0 output is 12V and CH1 output is 5V. In addition, this demo board has an on-board dynamic load circuit, which makes it easy to evaluate the transient performances.

The DC2155A powers up to default settings and produces power based on configuration resistors or its program file loaded within its onboard EEPROM without the need for any serial bus communication. This allows easy evaluation

of the DC/DC converter aspects of the LTC3886. To fully explore the extensive power system management features of the parts, download the GUI software LTpowerPlay® onto your PC and use LTC's I²C/SMBus/PMBus Dongle DC1613A to connect to the board. LTpowerPlay allows the user to reconfigure the part on the fly and store the configuration in EEPROM, view telemetry of voltage, current, temperature and fault status.

GUI Software Download

The software can be downloaded from:

[LTpowerPlay](#)

For more details and instructions of LTpowerPlay, please visit Help menu in LTpowerPlay.

[Design files for this circuit board are available.](#)

All registered trademarks and trademarks are the property of their respective owners.

PERFORMANCE SUMMARY Specifications are at T_A = 25°C

DC2155A-A Assembly (Dual Output, LTC3886 Only)

SYMBOL	PARAMETER	CONDITIONS	MIN	TYP	MAX	UNITS
V _{IN}	Input Supply Range		18	32	54	V
FSW	Factory Default Switching Frequency			150		kHz
V _{OUT0}	CH0 Factory Default Output Voltage	I _{OUT0} = 0A to 12A, V _{IN} = 18V to 54V		12		V
I _{OUT0}	CH0 Output Current Range		0		12	A
EFF	CH0 Efficiency	V _{OUT0} = 12V, V _{IN} = 32V, I _{OUT} = 12A, See Figure 6a		96.2		%
V _{OUT1}	CH1 Factory Default Output Voltage	I _{OUT1} = 0A to 12A, V _{IN} = 18V to 54V		5		V
I _{OUT1}	CH1 Output Current Range		0		12	A
EFF	CH1 Efficiency	V _{OUT1} = 5V, V _{IN} = 32V, I _{OUT} = 12A, See Figure 6b		93.6		%

DEMO MANUAL

DC2155A-A/DC2155A-B

PERFORMANCE SUMMARY Specifications are at $T_A = 25^\circ\text{C}$

DC2155A-B Assembly (Four-Phase Single Output, LTC3886 and LTC3870)

SYMBOL	PARAMETER	CONDITIONS	MIN	TYP	MAX	UNITS
V_{IN}	Input Supply Range		18	32	54	V
V_{OUT0}	Factory Default Output Voltage	$I_{OUT} = 0\text{A TO } 48\text{A}$, $V_{IN} = 18\text{V to } 54\text{V}$		12		V
I_{OUT0}	Output Current Range		0		48	A
FSW	Factory Default Switching Frequency			150		kHz
EFF	Efficiency	$V_{IN} = 32\text{V}$, $V_{OUT} = 12\text{V}$, $I_{OUT} = 48\text{A}$, See Figure 7		96.9		%

QUICK START PROCEDURE

Demonstration circuit 2155A makes it easy to set up to evaluate the performances of the LTC3886. Refer to Figure 1 and Figure 2 for proper measurement equipment setup and follow the procedure below:

NOTE. When measuring the input or output voltage ripple, care must be taken to avoid a long ground lead on the oscilloscope probe. Measure the output voltage ripple by touching the probe tip directly across the C10 for CH0 and C26 for CH1. See Figure 5 for proper scope probe technique.

1. Make sure jumpers are in the following positions:

JUMPER	POSITION	FUNCTION
JP1	ON	EXT 5V (on-board bias supply) for $EXTV_{CC}$ and dynamic load circuit
JP2	NC for DC2155A-A; C for DC2155A-B	$\overline{\text{FAULT0}}$ to $\overline{\text{FAULT1}}$
JP3	NC for DC2155A-A; C for DC2155A-B	RUN0 to RUN1
JP5	INT	External or on-board pulse generator for transient circuit
JP6	OFF	On-board pulse generator ON/OFF

2. With power off, connect the input power supply to V_{IN} and GND. Connect active load to output.

3. Make sure both RUN switches (SW1, SW2) are OFF.
4. Turn on the power at the input.

NOTE. Make sure that the input voltage does not exceed 54V.

5. Turn on both SW1 (for RUN0), and SW2 (for RUN1) switches, as desired.
6. Check for the correct output voltage from E5 to E6 for CH0, E7 to E8 for CH1. For DC2155A-A version, $V_{OUT0} = 12.0\text{V} \pm 0.5\%$ (11.94V ~ 12.06V), $V_{OUT1} = 5\text{V} \pm 0.5\%$ (4.975V ~ 5.025V). For DC2155A-B version, $V_{OUT0} = 12.0\text{V} \pm 0.5\%$ (11.94V ~ 12.06V).

NOTE. If there is no output, temporarily disconnect the load to make sure that the load is not set too high.

7. Once the proper output voltage is established, adjust the loads within the operating range and observe the output voltage regulation, ripple voltage, efficiency and other parameters.
8. Connect the dongle and control the output voltage from the GUI. See "LTpowerPlay QUICK START" session for details.

QUICK START PROCEDURE

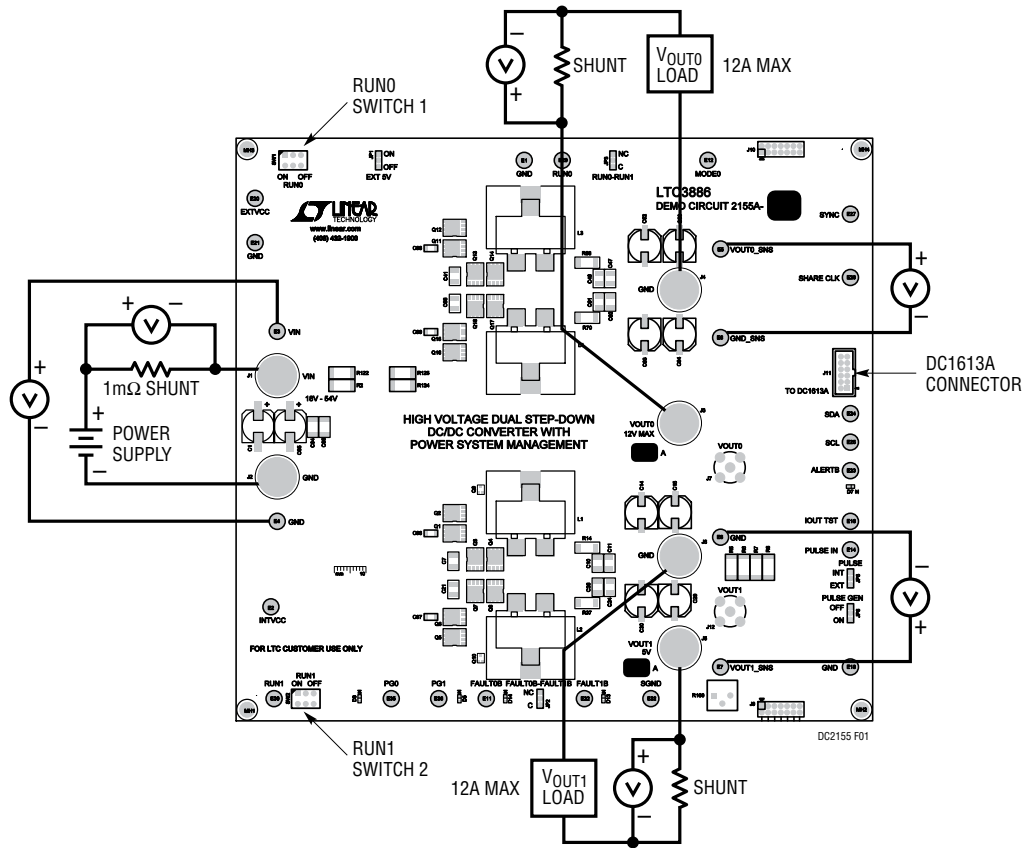

Figure 1. Test Setup for DC2155A-A

DEMO MANUAL

DC2155A-A/DC2155A-B

QUICK START PROCEDURE

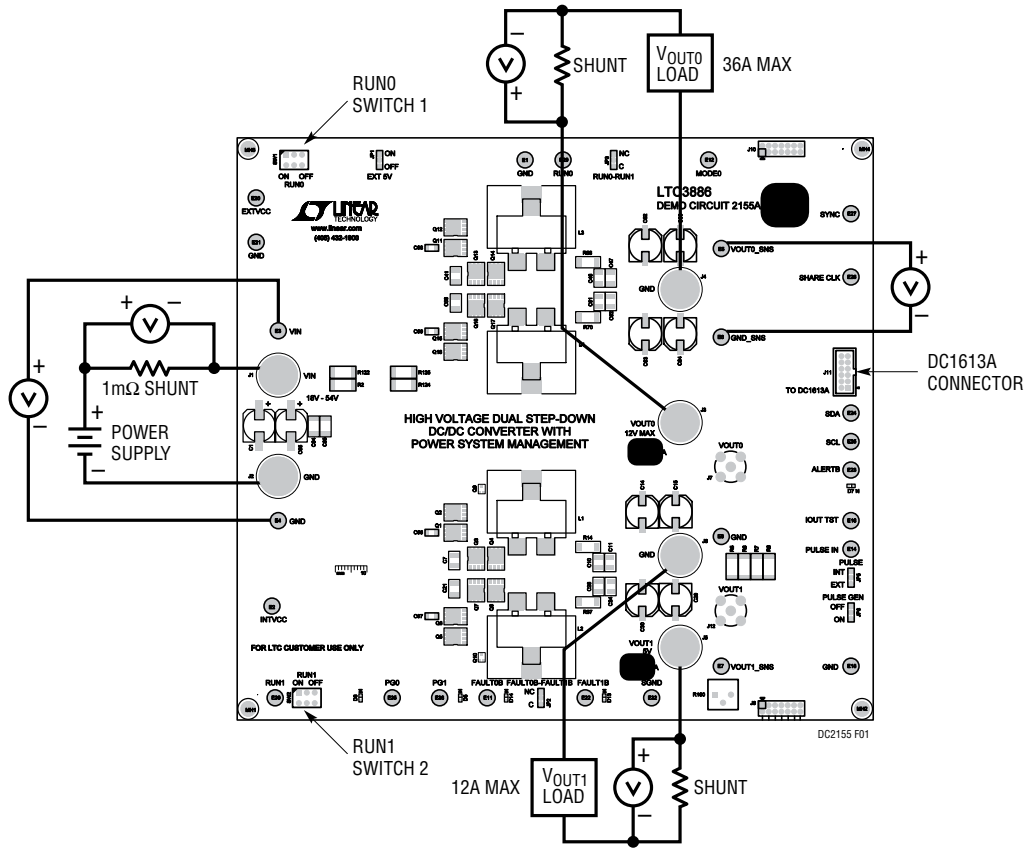

Figure 2. Test Setup for DC2155A-B

QUICK START PROCEDURE

Connecting a PC to DC2155A

You can use a PC to reconfigure the power management features of the LTC3886 such as: nominal V_{OUT} , margin set points, OV/UV limits, temperature fault limits,

sequencing parameters, the fault log, fault responses, GPIO and other functionality. The DC1613A dongle may be plugged in regardless of whether or not V_{IN} is present. Dongle can be hot plugged.

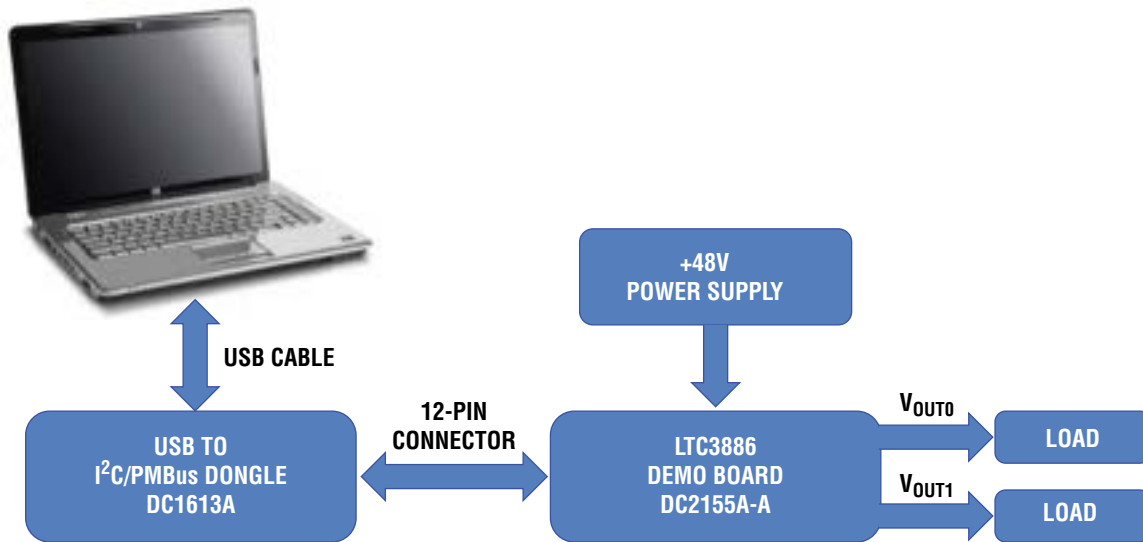

Figure 3. Demo Setup with PC for DC2155A-A

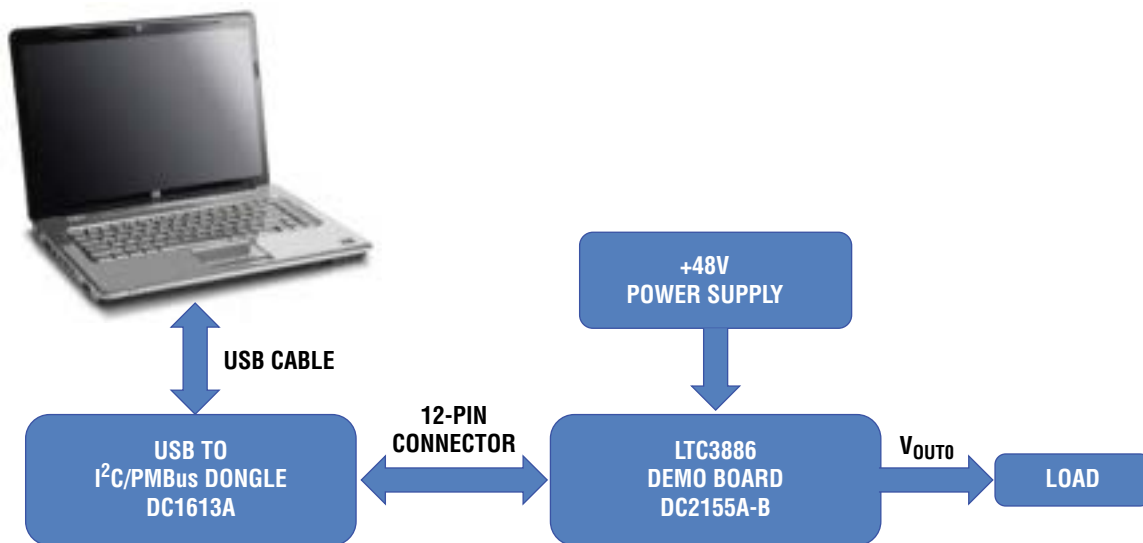

Figure 4. Demo Setup with PC for DC2155A-B

QUICK START PROCEDURE

Measuring Efficiency

To accurately measure efficiency of any configuration, do the following:

- Set JP6 to OFF position to disable the pulse generator circuits.
- DC2155A-A version. Measure V_{IN} across the input ceramic capacitor (C7 for CH0, C21 for CH1). Measure V_{OUT} across the output ceramic capacitor (C10 for CH0, C26 for CH1).

- DC2155A-B version. Measure V_{IN} across the input ceramic capacitor C7. Measure V_{OUT} across the output ceramic capacitor C10.

Measuring Output Ripple Voltage

An accurate ripple measurement may be performed by using the below configuration across C10/C26.

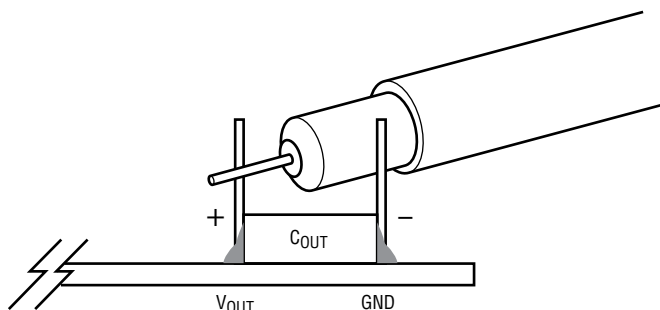
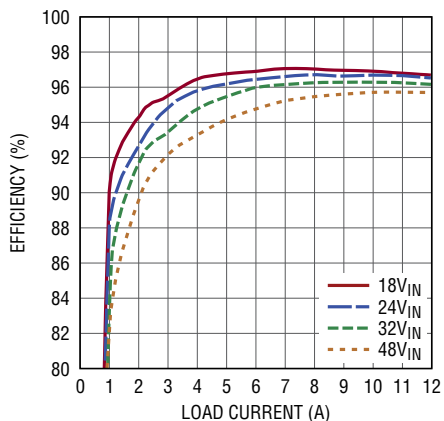

Figure 5. Measuring Output Voltage Ripple



$I_{LOAD} = 0A$ to $12A$
 $f_{SW} = 150kHz$
 $EXTV_{CC} = 12V$ (TIED TO V_{OUT})
 ONE OUTPUT RAIL IS
 ENABLED AT A TIME.

DC2155 F06a

(a) DC2155A-A: Efficiency at 12V_{OUT}

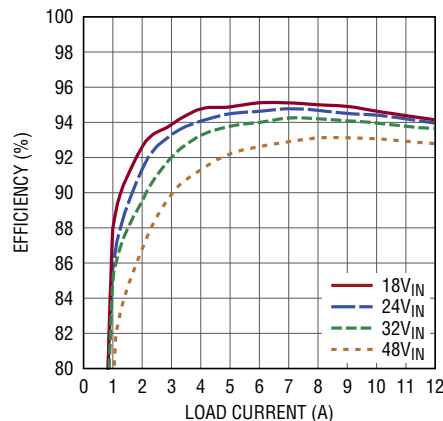

$I_{LOAD} = 0A$ to $12A$
 $f_{SW} = 150kHz$
 $EXTV_{CC} = 5V$ (TIED TO V_{OUT})
 ONE OUTPUT RAIL IS
 ENABLED AT A TIME.

DC2155 F06b

(b) DC2155A-A: Efficiency at 5V_{OUT}

Figure 6.

QUICK START PROCEDURE

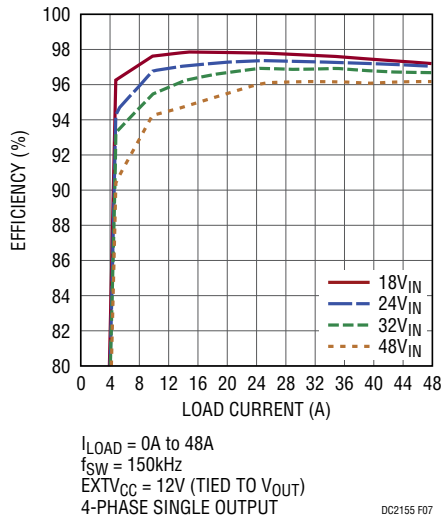
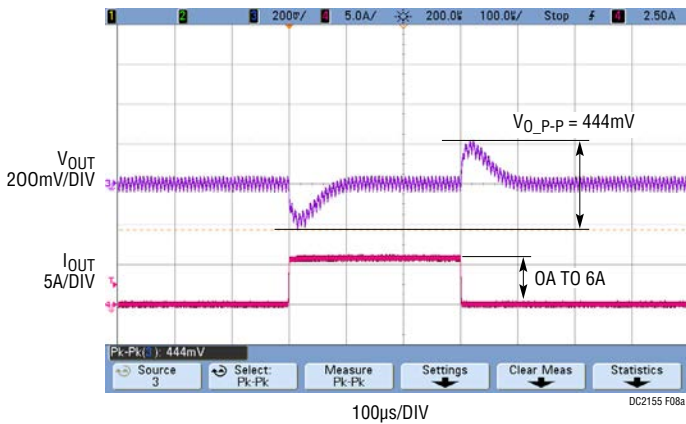
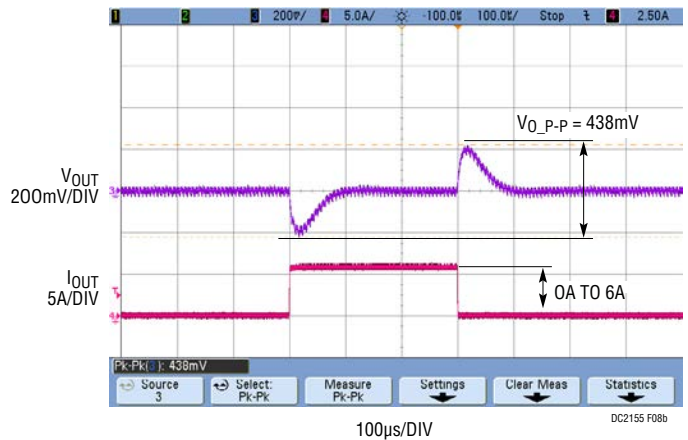

Figure 7. DC2155A-B: Efficiency at 12V_{OUT}



$V_{IN} = 32V$
 $V_{OUT0} = 12V$
 $f_{SW} = 150kHz$
 $I_{LOAD} \text{ STEP} = 0A \text{ TO } 6A \text{ AT } 6A/\mu s$
 (DEFAULT SET-UP)

(a) DC2155A-A Load Step Response, 12V_{OUT}



$V_{IN} = 32V$
 $V_{OUT1} = 5V$
 $f_{SW} = 150kHz$
 $I_{LOAD} \text{ STEP} = 0A \text{ TO } 6A \text{ AT } 6A/\mu s$
 (DEFAULT SET-UP)

(b) DC2155A-A Load Step Response, 5V_{OUT}

Figure 8. DC2155A-A Load Step Response

DEMO MANUAL

DC2155A-A/DC2155A-B

QUICK START PROCEDURE

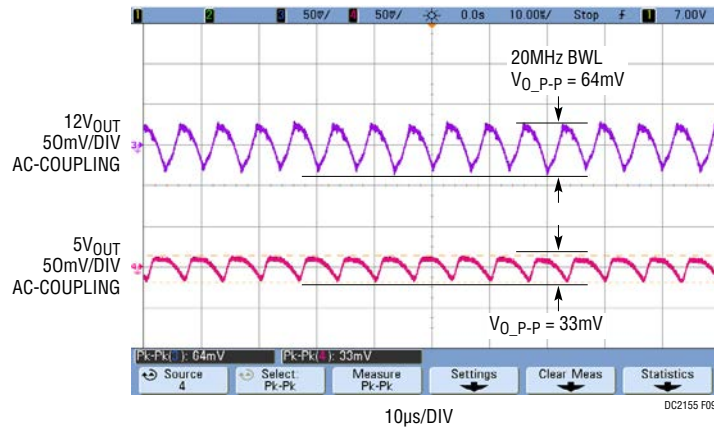

V_{IN} = 32V
V_{OUT0} = 12V AT 12A
V_{OUT1} = 5V AT 12A
f_{SW} = 150kHz
(DEFAULT SET-UP)

Figure 9. DC2155A-A Output Ripple Voltages

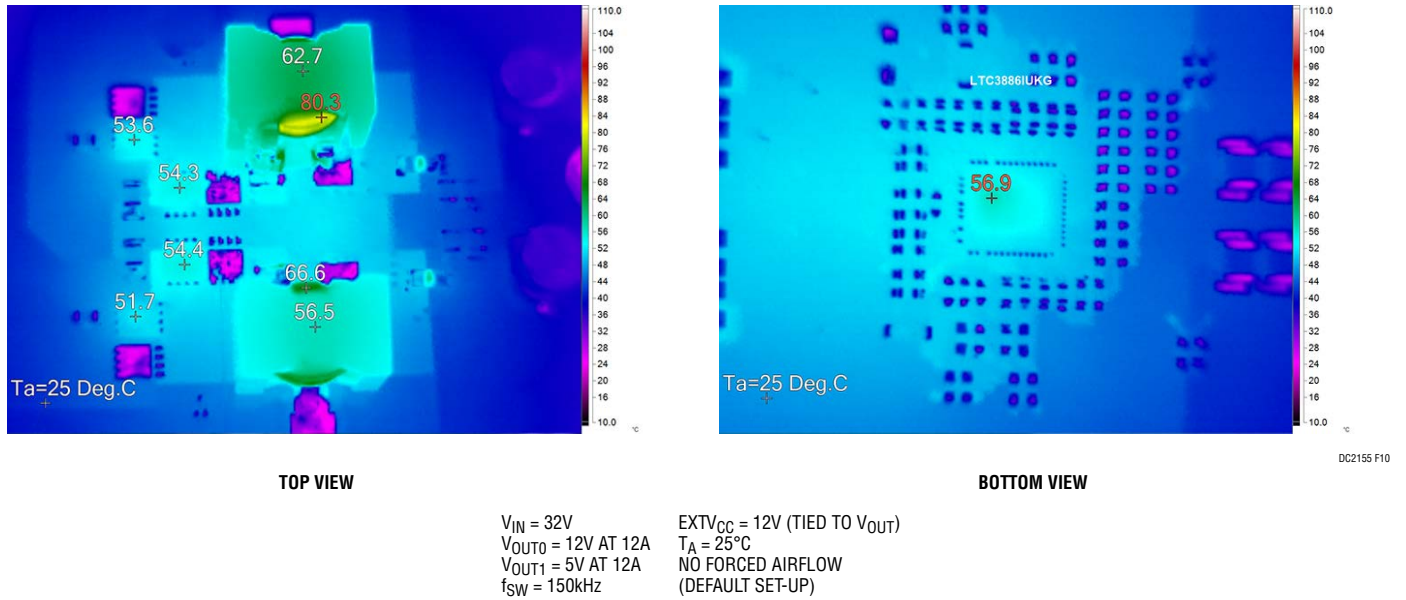

Figure 10. DC2155A-A Thermal Performance

QUICK START PROCEDURE

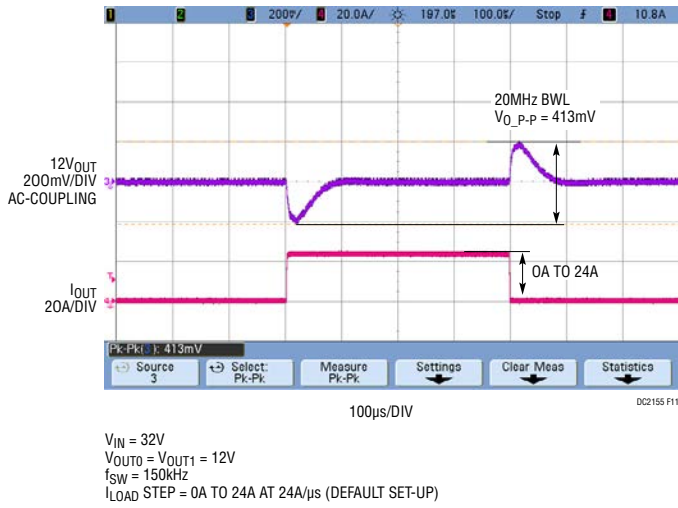

Figure 11. DC2155A-B Load Step Response $V_{IN} = 32V$

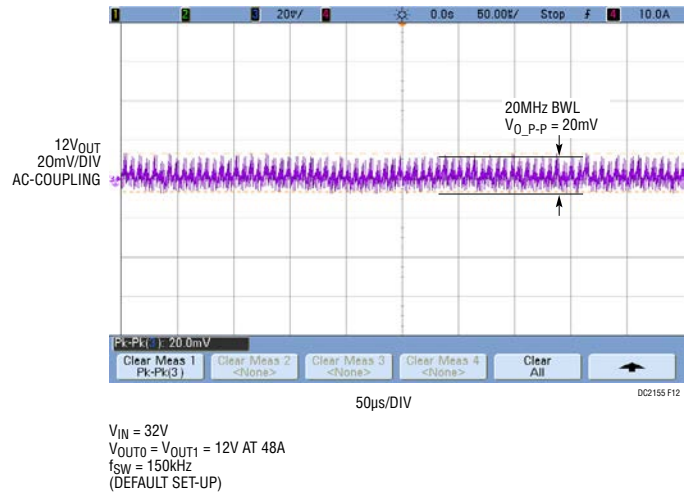
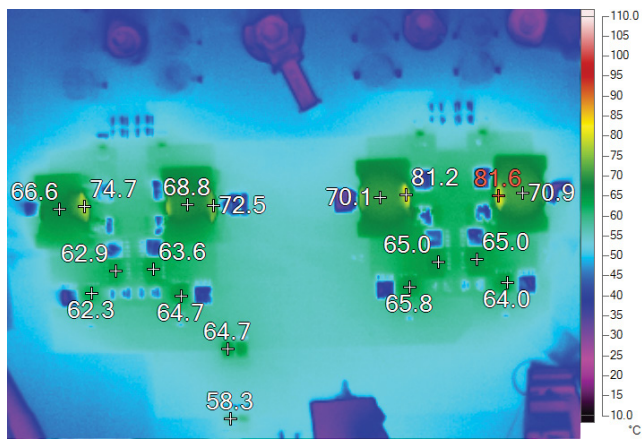
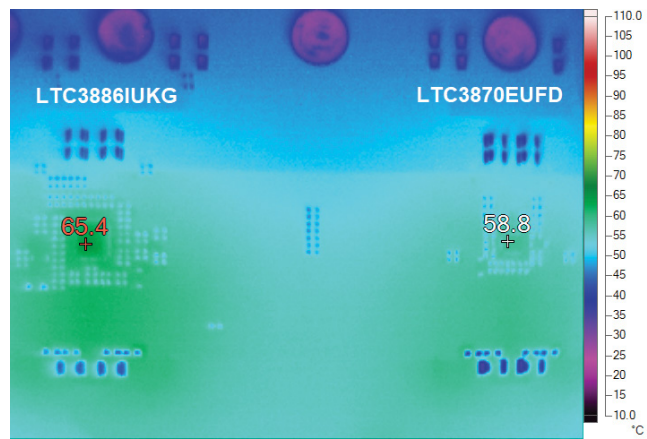

Figure 12. DC2155A-B Output Ripple Voltages



TOP VIEW

$V_{IN} = 32V$
 $V_{OUT0} = V_{OUT1} = 12V AT 48A$
 $f_{SW} = 150kHz$
 $LTC3886 EXT_{V_{CC}} = 12V$ (TIED TO V_{OUT0})



BOTTOM VIEW

$LTC3870 EXT_{V_{CC}} = 5V$ (TIED TO 5V ON-BOARD
 EXTERNAL BIAS SUPPLY VOLTAGE FROM U3)
 $T_A = 25^\circ C$
 NO FORCED AIRFLOW
 (DEFAULT SET-UP)

Figure 13. DC2155A-B Thermal Performance

DEMO MANUAL

DC2155A-A/DC2155A-B

LTpowerPlay SOFTWARE GUI

LTpowerPlay is a powerful Windows based development environment that supports Analog Devices power system management ICs, including the LTC3880, LTC3883, LTC3882, LTC3887 and LTC3886. The software supports a variety of different tasks. You can use LTpowerPlay to evaluate Analog Devices ICs by connecting to a demo board system. LTpowerPlay can also be used in an offline mode (with no hardware present) in order to build a multichip configuration file that can be saved and reloaded at a later time. LTpowerPlay provides unprecedented diagnostic and debug features. It becomes a valuable diagnostic tool during board bring-up to program or tweak the power management scheme in a system, or to diagnose

power issues when bringing up rails. LTpowerPlay utilizes the DC1613A USB-to-SMBus controller to communicate with one of many potential targets, including the LTC3886's DC2155A demo system, or a customer board. The software also provides an automatic update feature to keep the software current with the latest set of device drivers and documentation. The LTpowerPlay software can be downloaded from:

[LTpowerPlay](#)

To access technical support documents for LTC Digital Power Products visit Help. View online help on the LTpowerPlay menu.

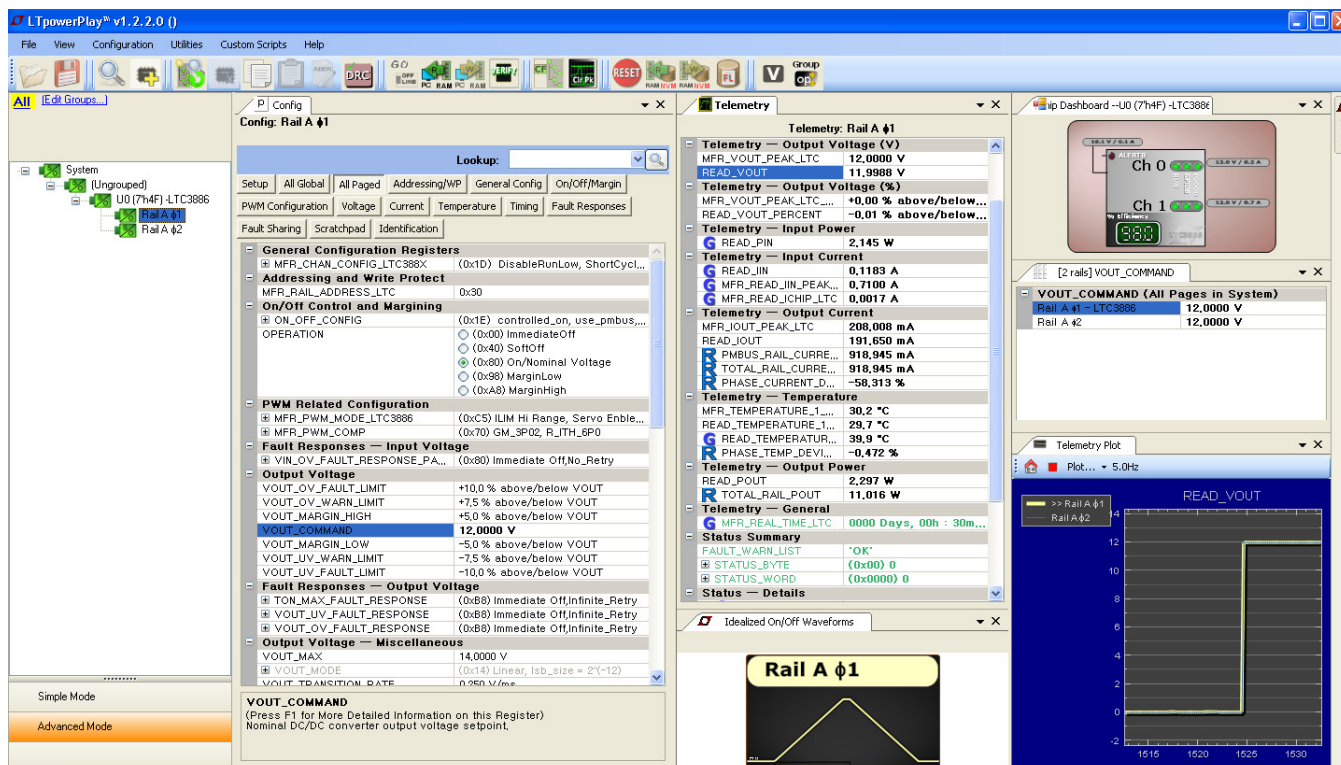

Figure 14. LTpowerPlay Main Interface

LTpowerPlay QUICK START PROCEDURE

The following procedure describes how to use LTpowerPlay to monitor and change the settings of LTC3886.

1. Download and install the LTpowerPlay GUI:

LTpowerPlay

2. Launch the LTpowerPlay GUI.

- a. The GUI should automatically identify the DC2155A. The system tree on the left hand side should look like this:

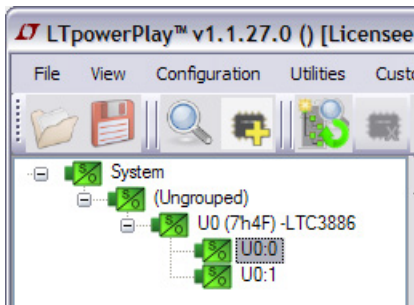

- b. A blue message box shows for a few seconds in the lower left hand corner, confirming that the LTC3886 is communicating:

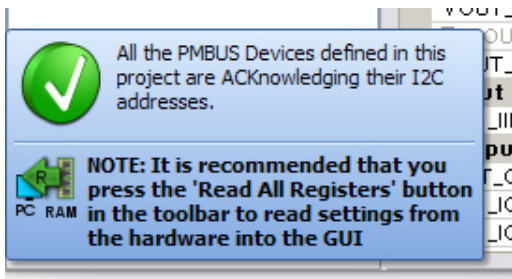

- c. In the Toolbar, click the “R” (RAM to PC) icon to read the RAM from the LTC3886. This reads the configuration from the RAM of LTC3886 and loads it into the GUI.



- d. If you want to change the output voltage to a different value, like 10V: in the Config tab, type in 10 in the VOUT_COMMAND box, like this:

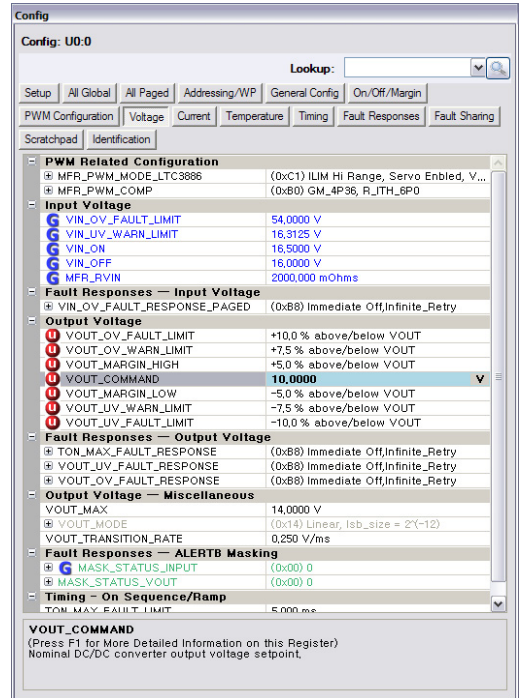

Then, click the “W” (PC to RAM) icon to write these register values to the LTC3886. After finishing this step, you will see the output voltage will change to 10V.



If the write is successful, you will see the following message:



- e. You can save the changes into the NVM. In the tool bar, click “RAM to NVM” button, as following:



- f. Save the demo board configuration to a (*.proj) file. Click the Save icon and save the file with a new file name.

DEMO MANUAL

DC2155A-A/DC2155A-B

PARTS LIST DC2155A-A

ITEM	QTY	REFERENCE	PART DESCRIPTION	MANUFACTURER/PART NUMBER
Required Circuit Components				
1	2	C1, C85	CAP, 56µF 20% 63V ELEC	SUNCON 63HVP56M
2	3	C3, C9, C23	CAP, 0603 0.1µF 10% 100V X7R	MURATA GRM188R72A104KA35D
3	4	C4, C5, C27, C33	CAP, 0603 10nF 10% 100V X7R	MURATA GRM188R72A103KA01D
4	3	C6, C13, C28	CAP, 0603 1nF 10% 100V X7R	AVX 06031C102KAT2A
5	5	C7, C8, C21, C22, C74	CAP, 1210 2.2µF 10% 100V X7R	MURATA GRM32ER72A225KA35L
6	8	C10, C11, C12, C24, C25, C26, C88, C93	CAP, 1210 22µF 20% 16V X7R	AVX 1210YC226MAT2A
7	4	C14, C15, C29, C30	CAP, 150µF 16V ELEC. OS-CON	PANASONIC 16SVP150M
8	2	C18, C34	CAP, 0603 4.7nF 10% 50V X7R	AVX 06035C472KAT2A
9	2	C20, C36	CAP, 0603 100pF 5% 50V C0G	AVX 06035A101JAT2A
10	2	C37, C38	CAP, 0603 2.2µF 10% 16V X5R	AVX 0603YD225KAT2A
11	1	C39	CAP, 0603 4.7µF 10% 10V X5R	AVX 0603ZD475KAT2A
12	1	C40	CAP, 0603 4.7µF 10% 16V X5R	MURATA GRM188R61C475KAAJD
13	2	C70, C103	CAP, 0805 2.2µF 10% 16V X7R	AVX 0805YC225KAT2A
14	1	C72	CAP, 0603 47nF 10% 25V X7R	AVX 06033C473KAT2A
15	1	C76	CAP, 0603 0.1µF 10% 25V X7R	AVX 06033C104KAT2A
16	1	C78	CAP, 0805 220nF 10% 100V X7R	MURATA GRM21AR72A224KAC5L
17	2	C79, C80	CAP, 1210 100µF 20% 10V X5R	MURATA GRM32ER61A107ME20L
18	1	C81	CAP, 0603 220pF 10% 50V X7R	AVX 06035C221KAT2A
19	2	C82, C83	CAP, 0603 10nF 10% 25V X7R	AVX 06033C103KAT2A
20	2	C84, C101	CAP, 0603 100nF 20% 16V X7R	AVX 0603YC104MAT2A
21	2	C94, C95	CAP, 1812 10µF 20% 100V X7S	TDK CKG45NX7S2A106M500JH
22	2	C96, C97	CAP, 1206 2.2µF 10% 100V X7R	MURATA GRM31CR72A225KA73L
23	1	C100	CAP, 0603 150pF 5% 50V NPO	AVX 06035A151JAT2A
24	1	C102	CAP, 0603 1µF 20% 25V X5R	AVX 06033D105MAT2A
25	2	D1, D2	DIODE, SCHOTTKY 100V, 1A	DIODES/ZETEX, DFSL1100-7
26	4	D5, D6, D13, D14	LED, 0603 GREEN	OSRAM LG L29K-G2J1-24-Z
27	1	D7	LED, 0603 RED	OSRAM LS L29K-H1J2-1-Z
28	1	D15	DIODE, SCHOTTKY, 30V, 250mW, 100mA, SOD-323	CENTRAL SEMI. CMDSH-3 TR
29	26	E1, E2, E3, E4, E5, E6, E7, E8, E11, E12, E14, E16, E18, E20, E21, E22, E23, E24, E25, E26, E27, E29, E30, E32, E35, E36	TURRET	MILL-MAX 2501-2-00-80-00-00-07-0
30	2	L1, L2	IND, 8.6µH	WURTH ELEKTRONIK 7443630860
31	1	L5	IND, 68µH	SUMIDA CDRH105RNP-680NC
32	2	Q1, Q6	XSTR, MOSFET N-CH 60V 47A 8 PIN PG-TDSON-8	INFINEON BSC094N06LS5
33	2	Q3, Q7	XSTR, MOSFET N-CH 60V 100A 8 PIN PG-TDSON-8	INFINEON BSC027N06LS5
34	2	Q9, Q10	XSTR, PNP GENERAL PURPOSE SOT-323	DIODES INC. MMST3906-7-F
35	1	Q19	XSTR., MOSFET, N-CH, 40V, TO-252 (DPAK)	VISHAY SUD50N04-8M8P-4GE3
36	1	Q20	XSTR, MOSFET P-CH 20V 5.2A SOT-23	VISHAY SI2365EDS-T1-GE3
37	4	Q22, Q23, Q28, Q29	XSTR, MOSFET N-CH 60V 115mA SOT23	FAIRCHILD 2N7002A

DEMO MANUAL

DC2155A-A/DC2155A-B

PARTS LIST DC2155A-A

ITEM	QTY	REFERENCE	PART DESCRIPTION	MANUFACTURER/PART NUMBER
38	2	R2, R122	RES, 2512 0.006Ω 1% 1W	PANASONIC ERJ-M1WSF6MU
39	2	R3, R4	RES, 0603 1k 5% 1/10W	VISHAY CRCW06031K00JNEA
40	4	R9, R12, R30, R38	RES, 0603 2Ω 5% 1/10W	VISHAY CRCW06032R00JNEA
41	12	R10, R11, R13, R15, R16, R18, R23, R25, R28, R89, R112, R113	RES, 0603 10k 5% 1/10W	VISHAY CRCW060310K0JNEA
42	2	R14, R37	RES, 2010 3mΩ 1% 1W	VISHAY WSL20103L000FEA18
43	14	R17, R21, R22, R27, R43, R44, R45, R96, R98, R106, R109, R128, R129, R132	RES, 0603 0Ω JUMPER	VISHAY CRCW06030000Z0EA
44	5	R24, R26, R50, R51, R155	RES, 0603 100Ω 5% 1/10W	VISHAY CRCW0603100RJNEA
45	4	R87, R88, R171, R172	RES, 0603 200Ω 5% 1/10W	VISHAY CRCW0603200RJNEA
46	1	R91	RES, 2010 0.01Ω 1% 2W	VISHAY WSL2010R0100FEK
47	1	R93	RES, 0603 127Ω 1% 1/10W	VISHAY CRCW0603127RFKEA
48	1	R99	RES, 0603 220k 5% 1/10W	VISHAY CRCW0603220KJNEA
49	2	R114, R115	RES, 0603 10Ω 5% 1/10W	VISHAY CRCW060310R0JNEA
50	2	R119, R120	RES, 0603 4.99k 1% 1/10W	VISHAY CRCW06034K99FKEA
51	2	R124, R125	RES, 2512 0Ω JUMPER	VISHAY CRCW25120000Z0EG
52	1	R146	RES, 0805 4.7Ω 1% 0.125W	VISHAY CRCW08054R70FKEA
53	1	R151	RES, 0603 1MΩ 5% 1/10W	VISHAY CRCW06031M00JNEA
54	1	R152	RES, 0603 681k 1% 1/10W	VISHAY CRCW0603681KFKEA
55	1	R153	RES, 0603 3.3Ω 1% 1/10W	VISHAY CRCW06033R30FKEA
56	1	R154	RES, 0603 82.5Ω 1% 1/10W	VISHAY CRCW060382R5FKEA
57	1	R157	RES, 0603 2Ω 5% 1/10W	VISHAY CRCW06032R00JNEA
58	1	R158	RES, 0603 27.4k 1% 1/10W	VISHAY CRCW060327K4FKEA
59	1	R159	RES, 0603 226K 1% 1/10W	VISHAY CRCW0603226KFKEA
60	1	R160	RES, VARIABLE 5k	BOURNS 3386P-1-502-LF
61	1	R161	RES, 0603 20k 5% 1/10W	VISHAY CRCW060320K0JNEA
62	1	R162	RES, 1206 0Ω JUMPER	VISHAY CRCW12060000Z0EA
63	1	R168	RES., 4.7Ω, 1%, 1/10W, 0603, AEC-Q200	VISHAY CRCW06034R70FKEA
64	1	R170	RES, 0603 340Ω 1% 1/10W	VISHAY CRCW0603340RFKEA
65	1	U1	IC, 60V DUAL OUTPUT STEP-DOWN CONTROLLER WITH DIGITAL POWER SYSTEM MANAGEMENT	ANALOG DEVICES, INC., LTC3886IUKG#10E2-1PBF-ES
66	1	U3	IC, SYNCHRONOUS STEP-DOWN CONVERTER	ANALOG DEVICES, INC. LTC3630EMSE#PBF
67	1	U4	IC, 24LC025/ST	MICROCHIP 24LC025-I/ST

Additional Demo Board Circuit Components

1	0	C16, C17, C31, C32, C51, C53, C65, C66	CAP, 7343 OPTION	OPTION
2	0	C19, C35, C43, C44, C45, C49, C54, C55, C56, C57, C60, C68, C69, C73	CAP, 0603 OPTION	OPTION
3	0	C41, C42, C46, C47, C48, C58, C59, C61, C62, C67, C75, C89, C90	CAP, 1210 OPTION	OPTION
4	0	C50, C52, C63, C64	CAP, 16V ELEC. OPTION	OPTION

DEMO MANUAL

DC2155A-A/DC2155A-B

PARTS LIST DC2155A-A

ITEM	QTY	REFERENCE	PART DESCRIPTION	MANUFACTURER/PART NUMBER
5	0	C71, C77, C91, C92	CAP, 0805 OPTION	OPTION
6	0	C86, C87	CAP, ELEC OPTION	OPTION
7	0	C98, C99	CAP, 1206 OPTION	OPTION
8	0	D3, D4, D9, D12	DIODE, OPTION	OPTION
9	0	D8	DIODE, ZENER OPTION	OPTION
10	0	L3, L4	IND, OPTION	OPTION
11	0	L7, L9	IND, 6.8μH OPTION	COILCRAFT SER2915H-682KL OPTION
12	0	Q27	XSTR, N-CHANNEL DMOS FET OPTION	OPTION
13	0	R5, R6, R7, R8	RES, 2512 0Ω JUMPER OPTION	RN5326 2512 TEPRO NAKOMA OPTION
14	0	Q2, Q4, Q5, Q8, Q11, Q12, Q13, Q14, Q15, Q16, Q17, Q18	XSTR, OPTION	OPTION
15	0	R19, R20, R29, R31, R32, R33, R34, R35, R36, R39, R40, R41, R42, R46, R47, R48, R49, R52, R53, R54, R55, R56, R57, R59, R60, R61, R62, R63, R64, R65, R66, R67, R68, R69, R71, R72, R73, R74, R75, R76, R77, R78, R79, R80, R81, R82, R83, R97, R100, R101, R102, R103, R104, R105, R108, R110, R111, R116, R117, R118, R121, R130, R131, R144, R145, R147, R148, R169, R173, R174	RES, 0603 OPTION	OPTION
16	0	R58, R70	RES, 2010 OPTION	OPTION
17	0	R90, R92, R94, R95	RES, 0805 OPTION	OPTION
18	0	R107	RES, 1206 OPTION	OPTION
19	0	R163	RES, 1206 0Ω JUMPER OPTION	VISHAY CRCW12060000Z0EA OPTION
20	0	U2	IC, POLYPHASE STEP-DOWN SLAVE CONTROLLER OPTION	ANALOG DEVICES, INC., LTC3870EUFD#PBF OPTION

Hardware:

1	5	JP1, JP2, JP3, JP5, JP6	HEADER, 3 PIN 2mm	SULLINS NRPN031PAEN-RC
2	6	J1, J2, J3, J4, J5, J6	STUD, TESTPIN	PEM KFH-032-10
3	2	J7, J12	CONN, BNC, 5 PINS	CONNEX 112404
4	1	J9	HEADER, 14PIN DUAL ROW R/A	MOLEX 87760-1416
5	1	J10	CONN, SOCKET 14PIN DUAL ROW R/A	SULLINSINC. NPPN072FJFN-RC
6	1	J11	HEADER, 12PIN 2mm STR DL	FCI 98414-G06-12ULF
7	6	J1, J2, J3, J4, J5, J6	LUG RING, #10	KEYSTONE 8205
8	4	MH1, MH2, MH3, MH4	STANDOFF, SNAP ON	KEYSTONE_8831
9	12	J1, J2, J3, J4, J5, J6	NUT, BRASS 10-32	ANY #10-32
10	2	SW1, SW2	SWITCH, SUBMINATURE SLIDE	C&K JS202011CQN
11	6	J1, J2, J3, J4, J5, J6	WASHER, #10 TIN PLATED BRASS	ANY #10 EXT BZ TN
12	5	XJP1, XJP2, XJP3, XJP5, XJP6	SHUNT	SAMTEC 2SN-BK-G

DEMO MANUAL

DC2155A-A/DC2155A-B

PARTS LIST DC2155A-B

ITEM	QTY	REFERENCE	PART DESCRIPTION	MANUFACTURER/PART NUMBER
Required Circuit Components				
1	2	C1, C85	CAP, 56µF, ALUM. ELECT., 63V, 20%, SMD	SUN ELECTRONIC INDUSTRIES CORP. 63HVP56M
2	6	C3, C9, C23, C44, C54, C60	CAP, 0603 0.1µF 10% 100V X7R	MURATA GRM188R72A104KA35J
3	2	C4, C5	CAP, 0603 10nF 10% 100V X7R	AVX 06031C103KAT2A
4	5	C6, C13, C28, C55, C68	CAP., 1000pF, X7R, 100V, 10%, 0603	AVX 06031C102KAT2A
5	9	C7, C8, C21, C22, C41, C42, C58, C59, C74	CAP, 1210 2.2µF 10% 100V X7R	MURATA GRM32ER72A225KA35L
6	16	C10, C11, C12, C24, C25, C26, C46, C47, C48, C61, C62, C67, C88, C89, C90, C93	CAP, 1210 22µF 20% 16V X7R	MURATA GRM32ER71C226MEA8L
7	8	C14, C15, C29, C30, C50, C52, C63, C64	CAP, 150µF 16V ELEC. OS-CON	PANASONIC 16SVP150M
8	1	C18	CAP, 0603 8.2nF 10% 50V X7R	AVX 06035C822KAT2A
9	2	C20, C36	CAP, 0603 100pF 5% 50V COG	AVX 06035A101JAT2A
10	4	C27, C33, C82, C83	CAP, 0603 10nF 10% 25V X7R	AVX 06033C103KAT2A
11	2	C37, C38	CAP, 0603 2.2µF 10% 16V X5R	AVX 0603YD225KAT2A
12	2	C39, C45	CAP, 0603 4.7µF 10% 10V X5R	AVX 0603ZD475KAT2A
13	2	C40, C43	CAP, 0603 4.7µF 10% 16V X5R	MURATA GRM188R61C475KAAJD
14	2	C49, C57	CAP, 0603 10pF 5% 50V COG	AVX 06035A100JAT2A
15	2	C70, C103	CAP, 0805 2.2µF 10% 16V X7R	AVX 0805YC225KAT2A
16	1	C72	CAP, 0603 47nF 10% 25V X7R	AVX 06033C473KAT2A
17	1	C76	CAP, 0603 0.1µF 10% 25V X7R	AVX 06033C104KAT2A
18	1	C78	CAP, 0805 220nF 10% 100V X7R	MURATA GRM21AR72A224KAC5L
19	2	C79, C80	CAP, 1210 100µF 20% 10V X5R	MURATA GRM32ER61A107ME20L
20	1	C81	CAP, 0603 220pF 10% 50V X7R	AVX 06035C221KAT2A
21	2	C84, C101	CAP, 0603 100nF 20% 16V X7R	AVX 0603YC104MAT2A
22	2	C94, C95	CAP, 1812 10µF 20% 100V X7S	TDK CKG45NX7S2A106M500JH
23	4	C96, C97, C98, C99	CAP, 1206 2.2µF 10% 100V X7R	MURATA GRM31CR72A225KA73L
24	1	C100	CAP, 0603 150pF 5% 50V NPO	AVX 06035A151JAT2A
25	1	C102	CAP, 0603 1µF 20% 25V X5R	AVX 06033D105MAT2A
26	4	D1, D2, D3, D4	DIODE, SCHOTTKY 100V, 1A	DIODES/ZETEX, DFLS1100-7
27	4	D5, D6, D13, D14	LED, 0603 GREEN	OSRAM LG L29K-G2J1-24-Z
28	1	D7	LED, 0603 RED	OSRAM LS L29K-H1J2-1-Z
29	1	D15	DIODE, SCHOTTKY, 30V, 250mW, 100mA, SOD-323	CENTRAL SEMI. CMDSH-3 TR
30	4	L1, L2, L3, L4	IND, 8.6µH	WURTH ELEKTRONIK 7443630860
31	1	L5	IND, 68µH	SUMIDA CDRH105RNP-680NC
32	4	Q1, Q6, Q11, Q15	XSTR, MOSFET N-CH 60V 47A 8 PIN PG-TDSON-8	INFINEON BSC094N06LS5
33	4	Q3, Q7, Q13, Q18	XSTR, MOSFET N-CH 60V 100A 8 PIN PG-TDSON-8	INFINEON BSC027N06LS5
34	2	Q9, Q10	XSTR, PNP GENERAL PURPOSE SOT-323	DIODES INC. MMST3906-7-F
35	1	Q19	XSTR, MOSFET, N-CH, 40V, TO-252 (DPAK)	VISHAY SUD50N04-8M8P-4GE3

DEMO MANUAL

DC2155A-A/DC2155A-B

PARTS LIST DC2155A-B

ITEM	QTY	REFERENCE	PART DESCRIPTION	MANUFACTURER/PART NUMBER
36	1	Q20	XSTR, MOSFET P-CH 20V 5.2A SOT-23	VISHAY SI2365EDS-T1-GE3
37	4	Q22, Q23, Q28, Q29	XSTR, MOSFET N-CH 60V 115mA SOT23	FAIRCHILD 2N7002A
38	2	R2, R122	RES, 2512 0.003Ω 1% 1W	PANASONIC ERJ-M1WTF3M0U
39	2	R3, R4	RES, 0603 1k 5% 1/10W	VISHAY CRCW06031K00JNEA
40	6	R5, R6, R7, R8, R124, R125	RES, 2512 0Ω JUMPER	VISHAY CRCW25120000Z0EG
41	7	R9, R12, R30, R38, R52, R53, R67	RES, 0603 2Ω 5% 1/10W	VISHAY CRCW06032R00JNEA
42	12	R10, R11, R13, R15, R16, R18, R23, R25, R28, R89, R112, R113	RES, 0603 10k 5% 1/10W	VISHAY CRCW060310K0JNEA
43	4	R14, R37, R58, R70	RES, 2010 3mΩ 1% 1W	VISHAY WSL20103L000FEA18
44	35	R17, R21, R22, R27, R43, R44, R45, R56, R57, R59, R60, R61, R62, R64, R66, R69, R73, R74, R78, R80, R81, R96, R98, R106, R109, R118, R121, R128, R129, R130, R131, R132, R148, R173, R174	RES, 0603 0Ω JUMPER	VISHAY CRCW06030000Z0EA
45	9	R24, R26, R50, R51, R63, R65, R75, R76, R155	RES, 0603 100Ω 5% 1/10W	VISHAY CRCW0603100RJNEA
46	1	R68	RES, 0603 49.9k 1% 1/10W	VISHAY CRCW060349K9FKEA
47	4	R87, R88, R171, R172	RES, 0603 200Ω 5% 1/10W	VISHAY CRCW0603200RJNEA
48	1	R91	RES, 2010 0.01Ω 1% 2W	VISHAY WSLP2010R0100FEA
49	1	R93	RES, 0603 127Ω 1% 1/10W	VISHAY CRCW0603127RFKEA
50	1	R99	RES, 0603 220k 5% 1/10W	VISHAY CRCW0603220KJNEA
51	2	R114, R115	RES, 0603 10Ω 5% 1/10W	VISHAY CRCW060310R0JNEA
52	2	R119, R120	RES, 0603 4.99k 1% 1/10W	VISHAY CRCW06034K99FKEA
53	1	R146	RES, 0805 4.7Ω 1% 0.125W	VISHAY CRCW08054R70FKEA
54	1	R151	RES, 0603 1MΩ 5% 1/10W	VISHAY CRCW06031M00JNEA
55	1	R152	RES, 0603 681k 1% 1/10W	VISHAY CRCW0603681KFKEA
56	1	R153	RES, 0603 3.3Ω 1% 1/10W	VISHAY CRCW06033R30FKEA
57	1	R154	RES, 0603 82.5Ω 1% 1/10W	VISHAY CRCW060382R5FKEA
58	1	R157	RES, 0603 2Ω 5% 1/10W	VISHAY CRCW06032R00JNEA
59	1	R158	RES, 0603 27.4k 1% 1/10W	VISHAY CRCW060327K4FKEA
60	1	R159	RES, 0603 226k 1% 1/10W	VISHAY CRCW0603226KFKEA
61	1	R160	RES, VARIABLE 5k	BOURNS 3386P-1-502-LF
62	1	R161	RES, 0603 20K 5% 1/10W	VISHAY CRCW060320K0JNEA
63	2	R162, R163	RES, 1206 0Ω JUMPER	VISHAY CRCW12060000Z0EA
64	1	R168	RES., 4.7Ω, 1%, 1/10W, 0603, AEC-Q200	VISHAY CRCW06034R70FKEA
65	1	R170	RES, 0603 340Ω 5% 1/10W	VISHAY CRCW0603340RJNEA
66	1	U1	IC, 60V DUAL OUTPUT STEP-DOWN CONTROLLER WITH DIGITAL POWER SYSTEM MANAGEMENT	ANALOG DEVICES, INC., LTC3886IUKG#10E3-1PBF-ES
67	1	U2	IC, POLYPHASE STEP-DOWN SLAVE CONTROLLER	ANALOG DEVICES, INC., LTC3870EUFDPBF
68	1	U3	IC, SYNCHRONOUS STEP-DOWN CONVERTER	ANALOG DEVICES, INC., LTC3630EMSE#PBF
69	1	U4	IC, 24LC025-I/ST	MICROCHIP 24LC025-I/ST
70	1	U5	IC, LTC6992IS6-1	ANALOG DEVICES, INC. LTC6992IS6-1

Rev. C

DEMO MANUAL

DC2155A-A/DC2155A-B

PARTS LIST DC2155A-B

ITEM	QTY	REFERENCE	PART DESCRIPTION	MANUFACTURER/PART NUMBER
71	1	U6	IC, SINGLE OP AMP	ANALOG DEVICES, INC., LT1803IS5

Additional Demo Board Circuit Components

1	0	C16, C17, C31, C32, C51, C53, C65, C66	CAP, 7343 OPTION	OPTION
2	0	C19, C34, C35, C56, C69, C73	CAP, 0603 OPTION	OPTION
3	0	C71, C77, C91, C92	CAP, 0805 OPTION	OPTION
4	0	C75	CAP, 1210 OPTION	OPTION
5	0	C86, C87	CAP, ELEC OPTION	OPTION
6	0	D8	DIODE, ZENER OPTION	OPTION
7	0	D9, D12	DIODE, OPTION	OPTION
8	0	L7, L9, L10, L11	IND, 6.8 μ H OPTION	COILCRAFT SER2915H-682KLOPTION COILCRAFTSER2918H-682KL OPTION
9	0	Q2, Q4, Q5, Q8, Q12, Q14, Q16, Q17	XSTR, OPTION	OPTION
10	0	Q27	XSTR, N-CHANNEL DMOS FET OPTION	OPTION
11	0	R19, R20, R29, R31, R32, R33, R34, R35, R36, R39, R40, R41, R42, R46, R47, R48, R49, R54, R55, R71, R72, R77, R79, R82, R83, R97, R100, R101, R102, R103, R104, R105, R108, R110, R111, R116, R117, R144, R145, R147, R169	RES, 0603 OPTION	OPTION
12	0	R90, R92, R94, R95	RES, 0805 OPTION	OPTION
13	0	R107	RES, 1206 OPTION	OPTION

Hardware:

1	26	E1, E2, E3, E4, E5, E6, E7, E8, E11, E12, E14, E16, E18, E20, E21, E22, E23, E24, E25, E26, E27, E29, E30, E32, E35, E36	TURRET	MILL-MAX 2501-2-00-80-00-00-07-0
2	4	MH1, MH2, MH3, MH4	STANDOFF, SNAP ON	KEYSTONE_8831
3	12	J1, J2, J3, J4, J5, J6	NUT, BRASS 10-32	ANY #10-32
4	6	J1, J2, J3, J4, J5, J6	WASHER, #10 TIN PLATED BRASS	ANY #10 EXT BZ TN
5	5	JP1, JP2, JP3, JP5, JP6	HEADER, 3 PIN 2mm	SULLINS NRPNO31PAEN-RC
6	6	J1, J2, J3, J4, J5, J6	STUD, TESTPIN	PEM KFH-032-10
7	2	J7, J12	CONN, BNC, 5 PINS	CONNEX 112404
8	1	J9	HEADER, 14PIN DUAL ROW R/A	MOLEX 87760-1416
9	1	J10	CONN, SOCKET 14PIN DUAL ROW R/A	SULLINS INC. NPPN072FJFN-RC
10	1	J11	HEADER, 12PIN 2mm STR DL	FCI 98414-G06-12ULF
11	6	J1, J2, J3, J4, J5, J6	LUG RING, #10	KEYSTONE 8205
12	2	SW1, SW2	SWITCH, SUBMINATURE SLIDE	C&K JS202011CQN
13	5	XJP1, XJP2, XJP3, XJP5, XJP6	SHUNT	SAMTEC 2SN-BK-G

DEMO MANUAL DC2155A-A/DC2155A-B

SCHEMATIC DIAGRAM

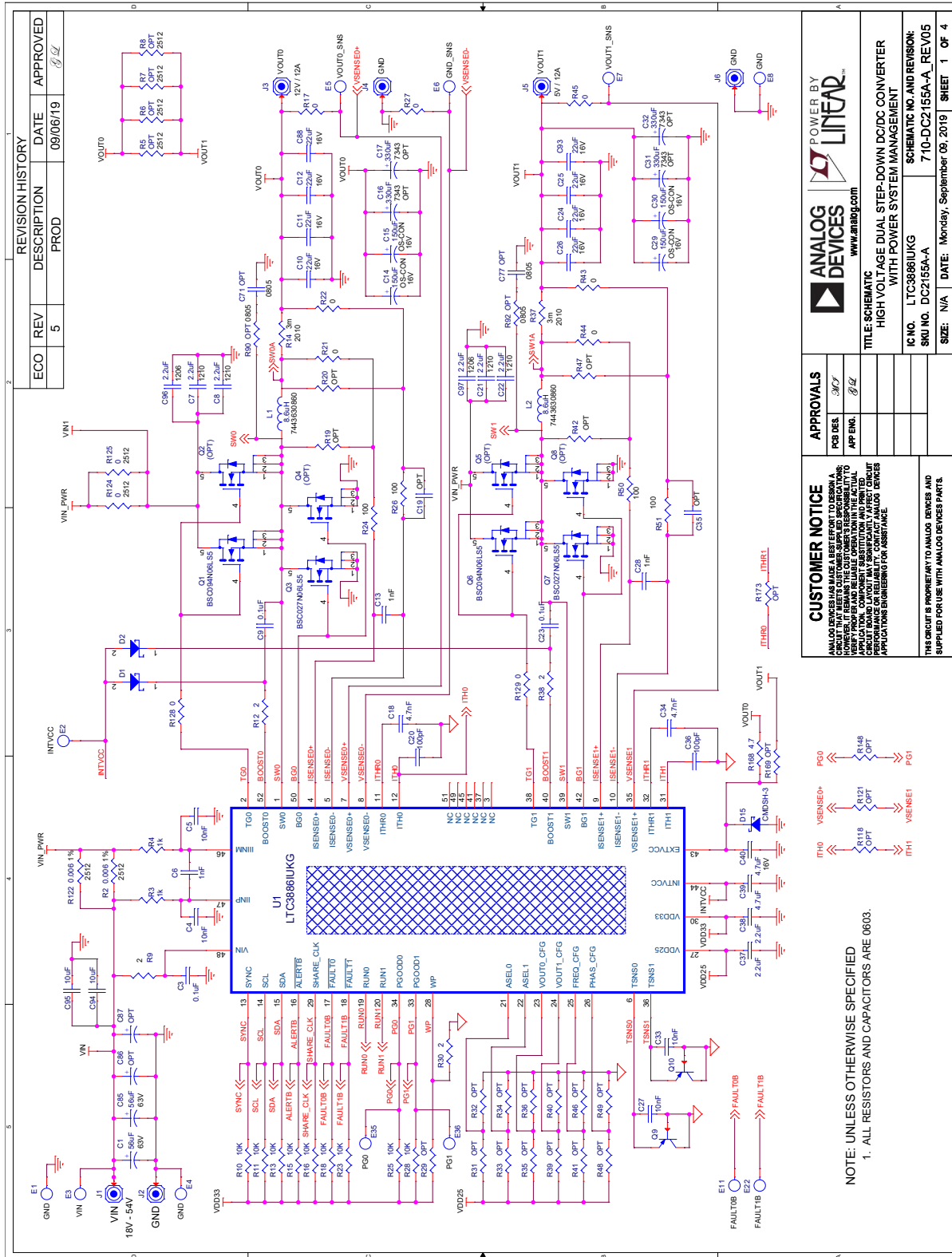
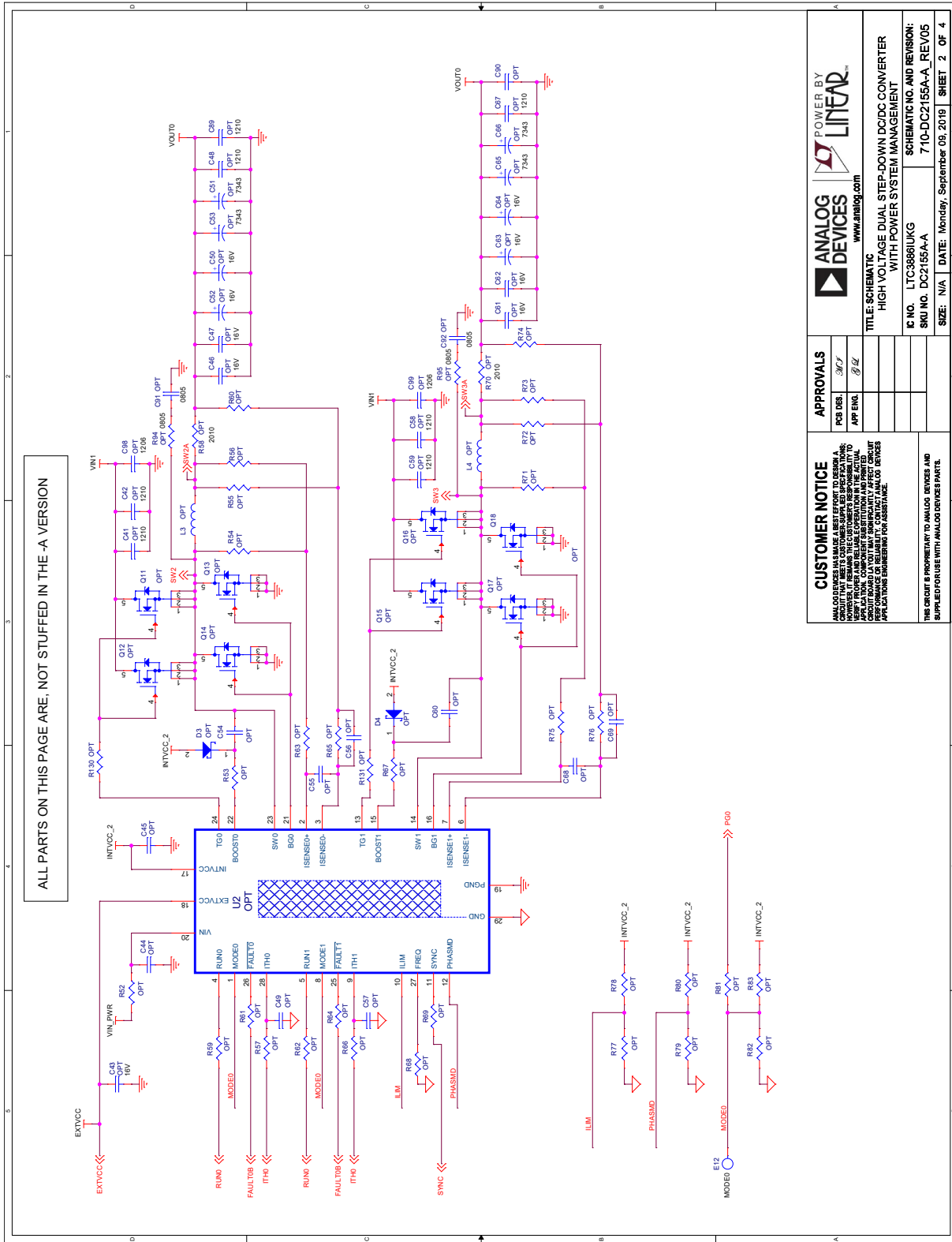

Figure 15a. DC2155A-A Demo Circuit Schematic, Sheet 1

SCHEMATIC DIAGRAM



CUSTOMER NOTICE		APPROVALS	
<p>ANALOG DEVICES IS A REGISTERED TRADEMARK OF ANALOG DEVICES INC. IN THE UNITED STATES AND OTHER COUNTRIES. ALL OTHER TRADEMARKS ARE THE PROPERTY OF THEIR RESPECTIVE OWNERS. THE INFORMATION IN THIS DOCUMENT IS PROVIDED AS A GUIDE ONLY. IT IS THE CUSTOMER'S RESPONSIBILITY TO VERIFY THE INFORMATION IN THIS DOCUMENT AGAINST THE ACTUAL DEVICE. ANALOG DEVICES ASSUMES NO LIABILITY FOR DAMAGES OR REPAIRS. CONTACT ANALOG DEVICES FOR A COMPLETE LIST OF PRODUCT SUPPORT PARTS.</p>		<p>PCB DES: <i>3/07</i></p> <p>APP ENG: <i>6/4</i></p>	<p>POWER BY ANALOG DEVICES www.analog.com</p>
<p>TITLE: SCHEMATIC HIGH VOLTAGE DUAL STEP-DOWN DC/DC CONVERTER WITH POWER SYSTEM MANAGEMENT</p>		<p>SCHEMATIC NO. AND REVISION: 710-DC2155A-A_REV/05</p>	
<p>IC NO: LTC3888LUG</p>		<p>SKU NO: DC2155A-A</p>	
<p>DATE: Monday, September 09, 2019</p>		<p>SHEET: 2 OF 4</p>	

Figure 15b. DC2155A-A Demo Circuit Schematic, Sheet 2

DEMO MANUAL

DC2155A-A/DC2155A-B

SCHEMATIC DIAGRAM

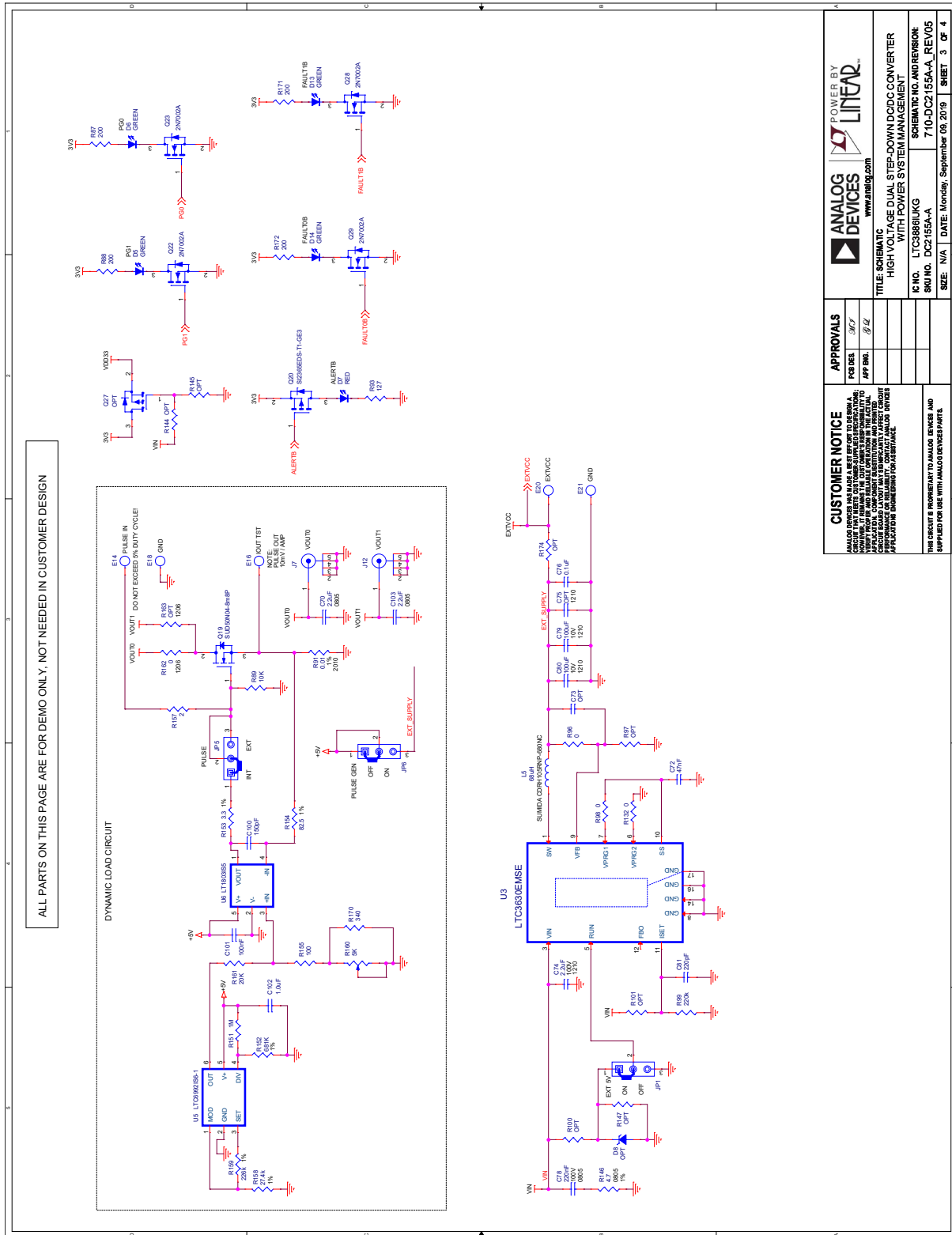
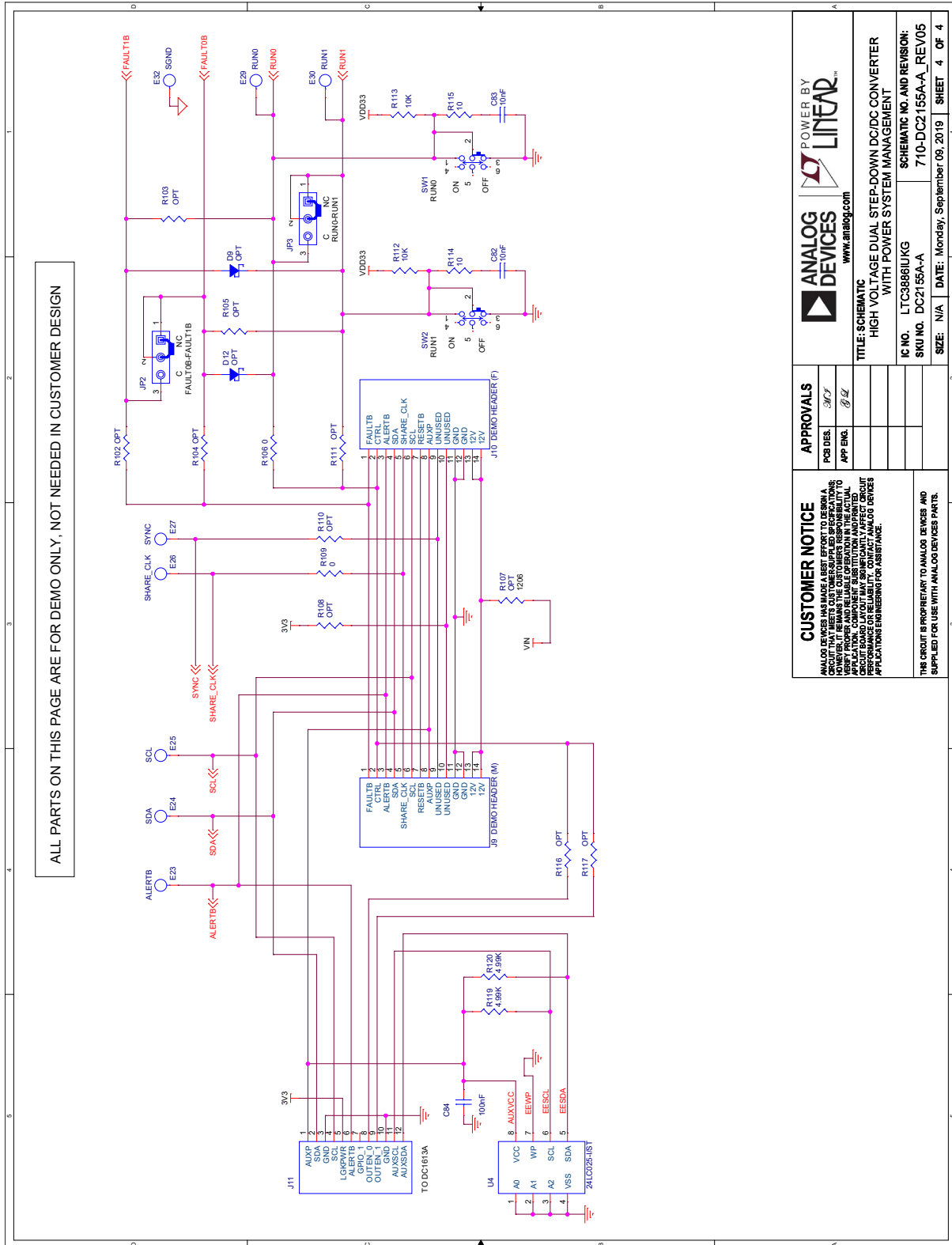

Figure 15c. DC2155A-A Demo Circuit Schematic, Sheet 3

SCHEMATIC DIAGRAM



ANALOG DEVICES www.analog.com		POWER BY LINEAR™	
TITLE: SCHEMATIC HIGH VOLTAGE DUAL STEP-DOWN DC/DC CONVERTER WITH POWER SYSTEM MANAGEMENT			
IC NO. LTC3886IJKG		SCHEMATIC NO. AND REVISION: 710-DC2155A-A_REV05	
SKU NO. DC2155A-A		DATE: Monday, September 09, 2019	
SIZE: N/A		SHEET: 4 OF 4	
CUSTOMER NOTICE ANALOG DEVICES MAKES NO REPRESENTATION OR WARRANTY, EITHER EXPRESS OR IMPLIED, THAT THIS CIRCUIT MEETS CUSTOMER SPECIFICATIONS. HOWEVER, IT REMAINS THE CUSTOMER'S RESPONSIBILITY TO VERIFY THAT THE CIRCUIT MEETS THE SPECIFICATIONS FOR THEIR APPLICATION. COMPONENT SUBSTITUTION AND PRINTED BOARD MANUFACTURING VARIATIONS MAY AFFECT PERFORMANCE OR RELIABILITY. CONTACT ANALOG DEVICES APPLICATIONS ENGINEERING FOR ASSISTANCE.		APPROVALS PCB DES. <i>3/27</i> APP. ENG. <i>B/L</i>	
THIS CIRCUIT IS PROPRIETARY TO ANALOG DEVICES AND SUPPLIED FOR USE WITH ANALOG DEVICES PARTS.			

Figure 15d. DC2155A-A Demo Circuit Schematic, Sheet 4

DEMO MANUAL

DC2155A-A/DC2155A-B

SCHEMATIC DIAGRAM

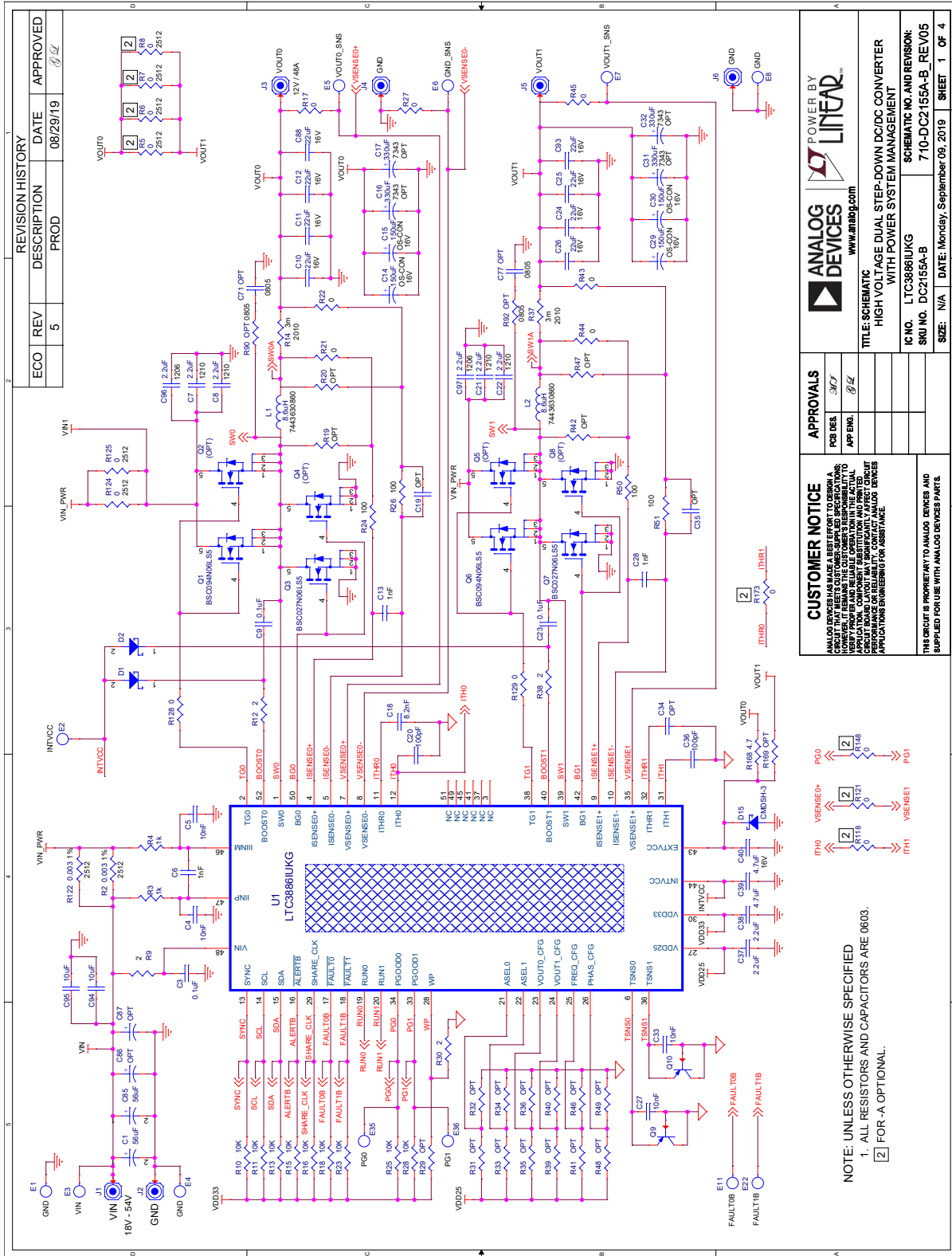

Figure 16a. DC2155A-B Demo Circuit Schematic, Sheet 1

SCHEMATIC DIAGRAM

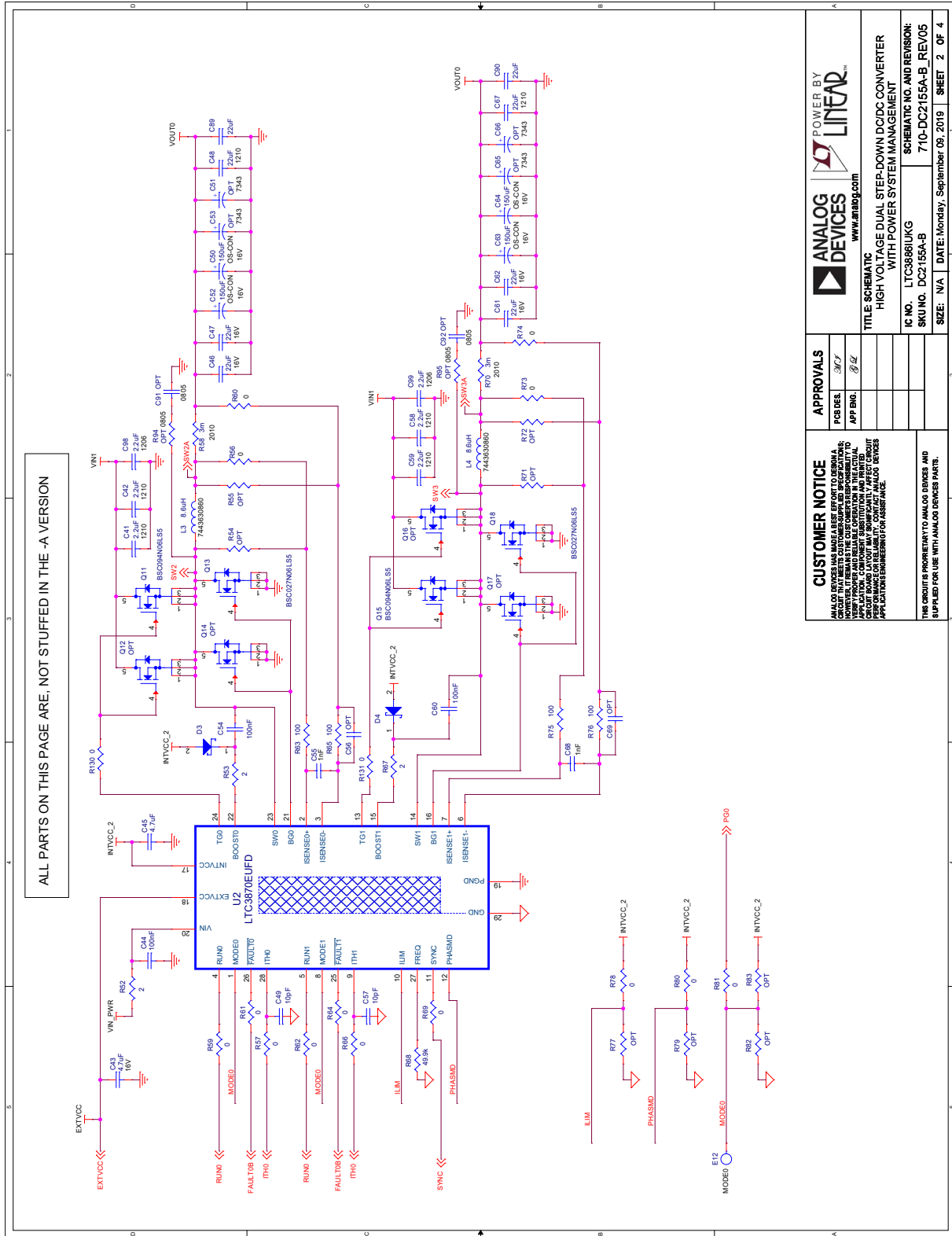

Figure 16b. DC2155A-B Demo Circuit Schematic, Sheet 2

DEMO MANUAL DC2155A-A/DC2155A-B

SCHEMATIC DIAGRAM

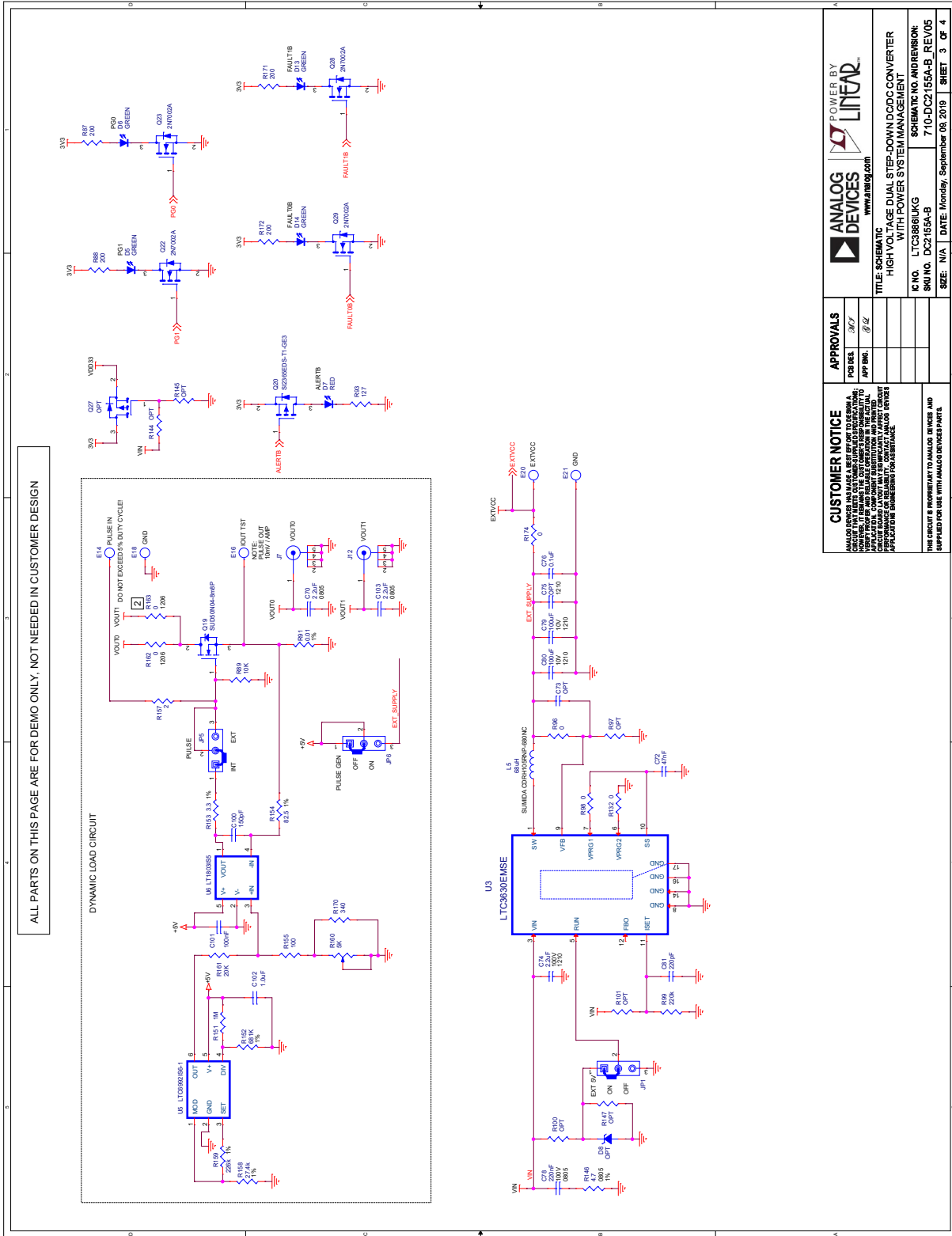

Figure 16c. DC2155A-B Demo Circuit Schematic, Sheet 3

DEMO MANUAL

DC2155A-A/DC2155A-B



ESD Caution

ESD (electrostatic discharge) sensitive device. Charged devices and circuit boards can discharge without detection. Although this product features patented or proprietary protection circuitry, damage may occur on devices subjected to high energy ESD. Therefore, proper ESD precautions should be taken to avoid performance degradation or loss of functionality.

Legal Terms and Conditions

By using the evaluation board discussed herein (together with any tools, components documentation or support materials, the "Evaluation Board"), you are agreeing to be bound by the terms and conditions set forth below ("Agreement") unless you have purchased the Evaluation Board, in which case the Analog Devices Standard Terms and Conditions of Sale shall govern. Do not use the Evaluation Board until you have read and agreed to the Agreement. Your use of the Evaluation Board shall signify your acceptance of the Agreement. This Agreement is made by and between you ("Customer") and Analog Devices, Inc. ("ADI"), with its principal place of business at One Technology Way, Norwood, MA 02062, USA. Subject to the terms and conditions of the Agreement, ADI hereby grants to Customer a free, limited, personal, temporary, non-exclusive, non-sublicensable, non-transferable license to use the Evaluation Board FOR EVALUATION PURPOSES ONLY. Customer understands and agrees that the Evaluation Board is provided for the sole and exclusive purpose referenced above, and agrees not to use the Evaluation Board for any other purpose. Furthermore, the license granted is expressly made subject to the following additional limitations: Customer shall not (i) rent, lease, display, sell, transfer, assign, sublicense, or distribute the Evaluation Board; and (ii) permit any Third Party to access the Evaluation Board. As used herein, the term "Third Party" includes any entity other than ADI, Customer, their employees, affiliates and in-house consultants. The Evaluation Board is NOT sold to Customer; all rights not expressly granted herein, including ownership of the Evaluation Board, are reserved by ADI. CONFIDENTIALITY. This Agreement and the Evaluation Board shall all be considered the confidential and proprietary information of ADI. Customer may not disclose or transfer any portion of the Evaluation Board to any other party for any reason. Upon discontinuation of use of the Evaluation Board or termination of this Agreement, Customer agrees to promptly return the Evaluation Board to ADI. ADDITIONAL RESTRICTIONS. Customer may not disassemble, decompile or reverse engineer chips on the Evaluation Board. Customer shall inform ADI of any occurred damages or any modifications or alterations it makes to the Evaluation Board, including but not limited to soldering or any other activity that affects the material content of the Evaluation Board. Modifications to the Evaluation Board must comply with applicable law, including but not limited to the RoHS Directive. TERMINATION. ADI may terminate this Agreement at any time upon giving written notice to Customer. Customer agrees to return to ADI the Evaluation Board at that time. LIMITATION OF LIABILITY. THE EVALUATION BOARD PROVIDED HEREUNDER IS PROVIDED "AS IS" AND ADI MAKES NO WARRANTIES OR REPRESENTATIONS OF ANY KIND WITH RESPECT TO IT. ADI SPECIFICALLY DISCLAIMS ANY REPRESENTATIONS, ENDORSEMENTS, GUARANTEES, OR WARRANTIES, EXPRESS OR IMPLIED, RELATED TO THE EVALUATION BOARD INCLUDING, BUT NOT LIMITED TO, THE IMPLIED WARRANTY OF MERCHANTABILITY, TITLE, FITNESS FOR A PARTICULAR PURPOSE OR NON-INFRINGEMENT OF INTELLECTUAL PROPERTY RIGHTS. IN NO EVENT WILL ADI AND ITS LICENSORS BE LIABLE FOR ANY INCIDENTAL, SPECIAL, INDIRECT, OR CONSEQUENTIAL DAMAGES RESULTING FROM CUSTOMER'S POSSESSION OR USE OF THE EVALUATION BOARD, INCLUDING BUT NOT LIMITED TO LOST PROFITS, DELAY COSTS, LABOR COSTS OR LOSS OF GOODWILL. ADI'S TOTAL LIABILITY FROM ANY AND ALL CAUSES SHALL BE LIMITED TO THE AMOUNT OF ONE HUNDRED US DOLLARS (\$100.00). EXPORT. Customer agrees that it will not directly or indirectly export the Evaluation Board to another country, and that it will comply with all applicable United States federal laws and regulations relating to exports. GOVERNING LAW. This Agreement shall be governed by and construed in accordance with the substantive laws of the Commonwealth of Massachusetts (excluding conflict of law rules). Any legal action regarding this Agreement will be heard in the state or federal courts having jurisdiction in Suffolk County, Massachusetts, and Customer hereby submits to the personal jurisdiction and venue of such courts. The United Nations Convention on Contracts for the International Sale of Goods shall not apply to this Agreement and is expressly disclaimed.

Компания «Океан Электроники» предлагает заключение долгосрочных отношений при поставках импортных электронных компонентов на взаимовыгодных условиях!

Наши преимущества:

- Поставка оригинальных импортных электронных компонентов напрямую с производств Америки, Европы и Азии, а так же с крупнейших складов мира;
- Широкая линейка поставок активных и пассивных импортных электронных компонентов (более 30 млн. наименований);
- Поставка сложных, дефицитных, либо снятых с производства позиций;
- Оперативные сроки поставки под заказ (от 5 рабочих дней);
- Экспресс доставка в любую точку России;
- Помощь Конструкторского Отдела и консультации квалифицированных инженеров;
- Техническая поддержка проекта, помощь в подборе аналогов, поставка прототипов;
- Поставка электронных компонентов под контролем ВП;
- Система менеджмента качества сертифицирована по Международному стандарту ISO 9001;
- При необходимости вся продукция военного и аэрокосмического назначения проходит испытания и сертификацию в лаборатории (по согласованию с заказчиком);
- Поставка специализированных компонентов военного и аэрокосмического уровня качества (Xilinx, Altera, Analog Devices, Intersil, Interpoint, Microsemi, Actel, Aeroflex, Peregrine, VPT, Syfer, Eurofarad, Texas Instruments, MS Kennedy, Miteq, Cobham, E2V, MA-COM, Hittite, Mini-Circuits, General Dynamics и др.);

Компания «Океан Электроники» является официальным дистрибьютором и эксклюзивным представителем в России одного из крупнейших производителей разъемов военного и аэрокосмического назначения «JONHON», а так же официальным дистрибьютором и эксклюзивным представителем в России производителя высокотехнологичных и надежных решений для передачи СВЧ сигналов «FORSTAR».



JONHON

«JONHON» (основан в 1970 г.)

Разъемы специального, военного и аэрокосмического назначения:

(Применяются в военной, авиационной, аэрокосмической, морской, железнодорожной, горно- и нефтедобывающей отраслях промышленности)

«FORSTAR» (основан в 1998 г.)

ВЧ соединители, коаксиальные кабели, кабельные сборки и микроволновые компоненты:

(Применяются в телекоммуникациях гражданского и специального назначения, в средствах связи, РЛС, а так же военной, авиационной и аэрокосмической отраслях промышленности).



Телефон: 8 (812) 309-75-97 (многоканальный)

Факс: 8 (812) 320-03-32

Электронная почта: ocean@oceanchips.ru

Web: <http://oceanchips.ru/>

Адрес: 198099, г. Санкт-Петербург, ул. Калинина, д. 2, корп. 4, лит. А