

Aluminum Capacitors +85 °C, Large Can

FEATURES

- Useful life: 2000 h at +85 °C
- The industry standard for large can aluminum capacitors
- Ideal for high wattage power supplies and energy storage applications
- Capacitance values to 2.2 F
- Largest CV available
- Highest voltage available
- Screw terminal
- Material categorization: for definitions of compliance please see www.vishay.com/doc?99912

**RoHS
COMPLIANT**

QUICK REFERENCE DATA	
DESCRIPTION	VALUE
Nominal case size Ø D x L in inches (mm)	1.375 x 1.625 (35.0 x 41.3) to 3.00 x 8.675 (76.2 x 220.3)
Operating temperature	-40 °C to +85 °C
Rated capacitance range, C _R	100 µF to 2.2 F
Tolerance on C _R	-10 % to 50 %
Rated voltage range, U _R	6.3 WV _{DC} to 450 WV _{DC}
Termination	Screw thread
Life validation test at 85 °C	2000 h: ΔCAP ≤ 15 % from initial measurement. ΔESR ≤ 1.5 x initial specified limit ΔDCL ≤ initial specified limit
Shelf life at 85 °C	500 h: ΔCAP ≤ 15 % from initial measurement. ΔESR ≤ 1.2 x initial specified limit. ΔDCL ≤ 2 x initial specified limit.
DC leakage current	$I = k \sqrt{CV}$ k = 4.0 at +25 °C; k = 32.0 at +85 °C I in µA, C in µF, V in Volts

RIPPLE CURRENT MULTIPLIERS			
TEMPERATURE			
AMBIENT TEMPERATURE		MULTIPLIERS	
+85 °C		1.0	
+75 °C		1.4	
+65 °C		1.7	
+55 °C and below		2.0	
FREQUENCY (Hz)			
RATED WV _{DC}	120	400	1000 AND UP
0 to 50	1.0	1.05	1.10
51 to 100	1.0	1.10	1.15
150 to 300	1.0	1.15	1.25
301 to 450	1.0	1.20	1.30

DIMENSIONS in inches (millimeters)							
LARGE CAN CAPACITORS							
CASE CODE	NOMINAL		WITH INSULATION SLEEVE			TERMINAL SPACING M ± 0.016 (0.4)	TYPICAL WEIGHT (g)
	D ± 0.032 (0.8)	L ± 0.063 (1.6)	D (Max.)	L (Max.)	P TERMINAL H (Max.)		
AN	1.375 (35.0)	1.625 (41.0)	1.453 (36.9)	1.750 (44.5)	1.849 (47.0)	0.500 (12.7)	43.0
AY	1.375 (35.0)	1.875 (48.0)	1.453 (36.9)	2.000 (50.8)	1.099 (53.3)	0.500 (12.7)	54.0
AA	1.375 (35.0)	2.125 (54.0)	1.453 (36.9)	2.250 (57.2)	1.349 (59.7)	0.500 (12.7)	63.0
AM	1.375 (35.0)	2.625 (67.0)	1.453 (36.9)	2.750 (69.9)	1.849 (72.4)	0.500 (12.7)	82.0
AB	1.375 (35.0)	3.125 (79.0)	1.453 (36.9)	3.250 (82.6)	1.349 (85.1)	0.500 (12.7)	105.0
AL	1.375 (35.0)	3.625 (92.0)	1.453 (36.9)	3.750 (95.3)	1.849 (97.8)	0.500 (12.7)	122.0
AC	1.375 (35.0)	4.125 (105.0)	1.453 (36.9)	4.250 (108.0)	1.349 (110.5)	0.500 (12.7)	129.0
AD	1.375 (35.0)	4.625 (117.0)	1.453 (36.9)	4.750 (120.7)	1.849 (123.2)	0.500 (12.7)	162.0
AE	1.375 (35.0)	5.125 (130.0)	1.453 (36.9)	5.250 (133.4)	1.349 (125.9)	0.500 (12.7)	179.0
AF	1.375 (35.0)	5.625 (143.0)	1.453 (36.9)	5.750 (146.1)	1.849 (148.6)	0.500 (12.7)	201.0
EN	1.750 (44.0)	1.625 (41.0)	1.828 (46.4)	1.750 (44.5)	1.849 (47.0)	0.750 (19.1)	71.0



DIMENSIONS in inches (millimeters)							
LARGE CAN CAPACITORS							
CASE CODE	NOMINAL		WITH INSULATION SLEEVE			TERMINAL SPACING M ± 0.016 (0.4)	TYPICAL WEIGHT (g)
	D ± 0.032 (0.8)	L ± 0.063 (1.6)	D (Max.)	L (Max.)	P TERMINAL H (Max.)		
EY	1.750 (44.0)	1.875 (48.0)	1.828 (46.4)	2.000 (50.8)	2.099 (53.3)	0.750 (19.1)	88.0
EA	1.750 (44.0)	2.125 (54.0)	1.828 (46.4)	2.250 (57.2)	2.349 (59.7)	0.750 (19.1)	102.0
EM	1.750 (44.0)	2.625 (67.0)	1.828 (46.4)	2.750 (69.9)	2.849 (72.4)	0.750 (19.1)	133.0
EB	1.750 (44.0)	3.125 (79.0)	1.828 (46.4)	3.250 (82.6)	3.349 (85.1)	0.750 (19.1)	167.0
EL	1.750 (44.0)	3.625 (92.0)	1.828 (46.4)	3.750 (95.3)	3.849 (97.8)	0.750 (19.1)	198.0
EC	1.750 (44.0)	4.125 (105.0)	1.828 (46.4)	4.250 (108.0)	4.349 (110.5)	0.750 (19.1)	230.0
ED	1.750 (44.0)	4.625 (117.0)	1.828 (46.4)	4.750 (120.7)	4.849 (123.2)	0.750 (19.1)	252.0
EE	1.750 (44.0)	5.125 (130.0)	1.828 (46.4)	5.250 (133.4)	5.349 (135.9)	0.750 (19.1)	269.0
EF	1.750 (44.0)	5.625 (143.0)	1.828 (46.4)	5.750 (146.1)	5.849 (148.6)	0.750 (19.1)	318.0
BY	2.000 (51.0)	1.875 (48.0)	2.078 (52.8)	2.000 (50.8)	2.099 (53.3)	0.875 (22.2)	113.0
BA	2.000 (51.0)	2.125 (54.0)	2.078 (52.8)	2.250 (57.2)	2.349 (59.7)	0.875 (22.2)	133.0
BM	2.000 (51.0)	2.625 (67.0)	2.078 (52.8)	2.750 (69.9)	2.849 (72.4)	0.875 (22.2)	176.0
BB	2.000 (51.0)	3.125 (79.0)	2.078 (52.8)	3.250 (82.6)	3.349 (85.1)	0.875 (22.2)	213.0
BL	2.000 (51.0)	3.625 (92.0)	2.078 (52.8)	3.750 (95.3)	3.849 (97.8)	0.875 (22.2)	261.0
BC	2.000 (51.0)	4.125 (105.0)	2.078 (52.8)	4.250 (108.0)	4.349 (110.5)	0.875 (22.2)	381.0
BD	2.000 (51.0)	4.625 (117.0)	2.078 (52.8)	4.750 (120.7)	4.849 (123.2)	0.875 (22.2)	326.0
BE	2.000 (51.0)	5.125 (130.0)	2.078 (52.8)	5.250 (133.4)	5.349 (135.9)	0.875 (22.2)	337.0
BF	2.000 (51.0)	5.625 (143.0)	2.078 (52.8)	5.750 (146.1)	5.849 (148.6)	0.875 (22.2)	408.0
CB	2.500 (64.0)	3.125 (79.0)	2.578 (65.5)	3.250 (82.6)	n/a	1.125 (28.6)	329.0
CL	2.500 (64.0)	3.625 (92.0)	2.578 (65.5)	3.750 (95.3)	n/a	1.125 (28.6)	400.0
CC	2.500 (64.0)	4.125 (105.0)	2.578 (65.5)	4.250 (108.0)	n/a	1.125 (28.6)	473.0
CD	2.500 (64.0)	4.625 (117.0)	2.578 (65.5)	4.750 (120.7)	n/a	1.125 (28.6)	562.0
CE	2.500 (64.0)	5.125 (130.0)	2.578 (65.5)	5.250 (133.4)	n/a	1.125 (28.6)	607.0
CF	2.500 (64.0)	5.625 (143.0)	2.578 (65.5)	5.750 (146.1)	n/a	1.125 (28.6)	675.0
DB	3.000 (76.0)	3.125 (79.0)	3.078 (78.2)	3.250 (82.6)	n/a	1.250 (31.8)	496.0
DL	3.000 (76.0)	3.625 (92.0)	3.078 (78.2)	3.750 (95.3)	n/a	1.250 (31.8)	598.0
DC	3.000 (76.0)	4.125 (105.0)	3.078 (78.2)	4.250 (108.0)	n/a	1.250 (31.8)	700.0
DD	3.000 (76.0)	4.625 (117.0)	3.078 (78.2)	4.750 (120.7)	n/a	1.250 (31.8)	802.0
DE	3.000 (76.0)	5.125 (130.0)	3.078 (78.2)	5.250 (133.4)	n/a	1.250 (31.8)	944.0
DF	3.000 (76.0)	5.625 (143.0)	3.078 (78.2)	5.750 (146.1)	n/a	1.250 (31.8)	1004.0
DJ	3.000 (76.0)	8.625 (219.0)	3.078 (78.2)	8.750 (222.3)	n/a	1.250 (31.8)	1403.0

DIMENSIONS in inches (millimeters)						
BRACKETS (RoHS COMPLIANT)						
TYPE	PART NUMBER	A	B	C	FIGURE NUMBER	
2 feet	1245860035A	1.375 (34.9)	1.781 (45.2)	2.218 (56.3)	1	
3 feet	1245860036A	2.000 (50.8)	2.500 (63.5)	2.875 (73.0)	2	
3 feet	1245860037A	2.500 (63.5)	3.000 (76.2)	3.375 (85.7)	2	
3 feet	1245860038A	3.000 (76.2)	3.500 (88.9)	3.875 (98.4)	2	
SCREW INSERT TERMINAL DIMENSIONS						
TERMINAL CODE	THREAD	THREAD DEPTH	HEIGHT J ± 0.032 (0.8)	DIAMETER S ± 0.010 (0.25)	DIAMETER T ± 0.010 (0.25)	NOTES
A	10-32 NF-28	0.219 (5.6)	0.063 (1.6)	0.313 (8.0)	0.438 (11.1)	All cases codes
B	10-32 NF-28	0.375 (9.5)	0.250 (6.4)	0.313 (8.0)	0.438 (11.1)	All cases codes
D	1/4-28 NF-28	0.344 (8.7)	0.093 (2.4)	0.688 (17.5)	-	C and D dia. codes only

DIMENSIONS AND AVAILABLE FORMS

Screw Insert Terminals

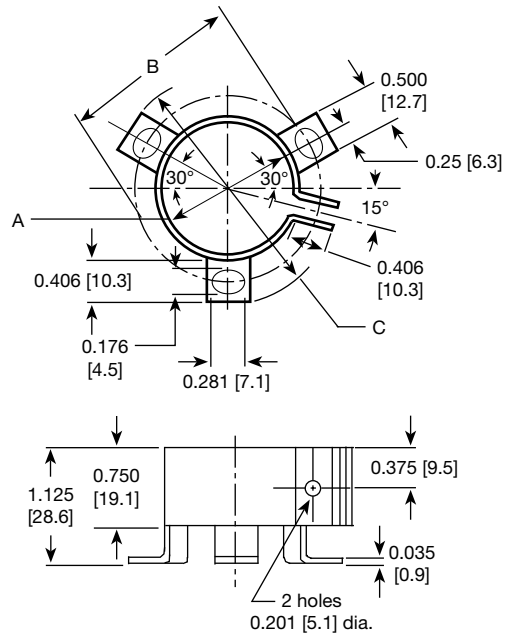
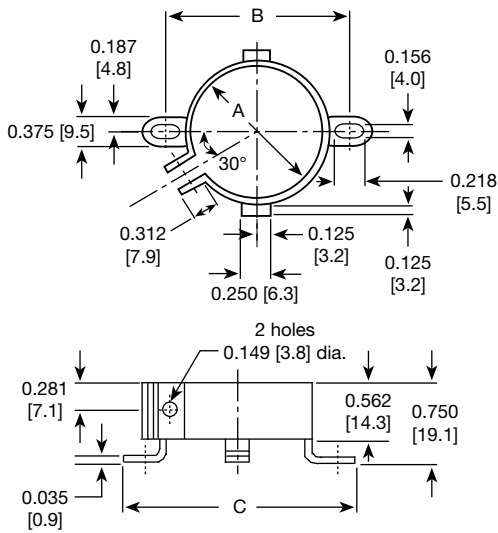
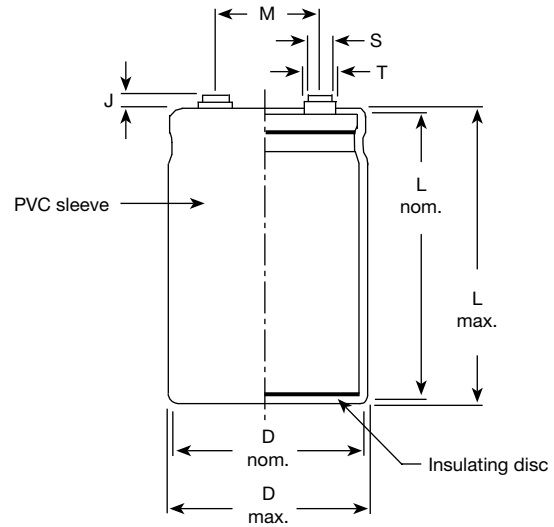
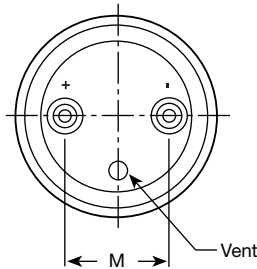

ORDERING EXAMPLE

Electrolytic capacitor 36DY series: 36DY 683 F 6R3 AA 2 A

DESCRIPTION	
CODE	EXPLANATION
36DY	Product type
683	Capacitance value (68 000 µF)
F	Tolerance (G = -10 % / +75 %; F = -10 % / +50 %)
6R3	Voltage rating at 85 °C (6.3 V)
AA	Can size (see Dimensions table)
2	PVC insulating sleeve
A	Terminal code (low insert 10-32 screw thread)



ELECTRICAL DATA AND ORDERING INFORMATION				
CAPACITANCE (μF)	PART NUMBER	NOMINAL CASE SIZE D x L	MAX. ESR AT 25 °C (mΩ) 120 Hz	MAX. RIPPLE AT +85 °C (A) 120 Hz
6.3 WV_{DC} AT +85 °C, SURGE = 8 V				
68 000.0	36DY683F6R3AA2A	1.375 x 2.125 (35.0 x 54.0)	32.0	5.92
120 000.0	36DY124F6R3AB2A	1.375 x 3.125 (35.0 x 79.0)	20.0	8.70
220 000.0	36DY224F6R3BB2A	2.000 x 3.125 (51.0 x 79.0)	11.2	14.4
560 000.0	36DY564F6R3BF2A	2.000 x 5.625 (51.0 x 143.0)	6.6	23.8
820 000.0	36DY824F6R3CF2A	2.500 x 5.625 (64.0 x 143.0)	4.1	34.4
1 000 000.0	36DY105F6R3DD2A	3.000 x 4.625 (76.0 x 117.0)	14.5	34.0
10 WV_{DC} AT +85 °C, SURGE = 12 V				
82 000.0	36DY823F010AB2A	1.375 x 3.125 (35.0 x 79.0)	19.8	8.65
150 000.0	36DY154F010AD2A	1.375 x 4.625 (35.0 x 117.0)	14.0	12.2
220 000.0	36DY224F010BL2A	2.000 x 3.625 (51.0 x 92.0)	9.6	16.5
390 000.0	36DY394F010BF2A	2.000 x 5.625 (51.0 x 143.0)	6.7	23.7
470 000.0	36DY474F010CC2A	2.500 x 4.125 (64.0 x 105.0)	5.0	27.6
680 000.0	36DY684F010DC2A	3.000 x 4.125 (76.0 x 105.0)	5.0	30.9
15 WV_{DC} AT +85 °C, SURGE = 18 V				
47 000.0	36DY473F015AM2A	1.375 x 2.625 (35.0 x 67.0)	25.0	7.19
68 000.0	36DY683F015AL2A	1.375 x 3.625 (35.0 x 92.0)	17.5	9.79
100 000.0	36DY104F015AD2A	1.375 x 4.625 (35.0 x 117.0)	14.2	12.1
56 000.0	36DY563F015BA2A	2.000 x 2.125 (51.0 x 54.0)	20.0	9.40
100 000.0	36DY104F015BB2A	2.000 x 3.125 (51.0 x 79.0)	11.6	14.2
150 000.0	36DY154F015BC2A	2.000 x 4.125 (51.0 x 105.0)	8.7	18.3
220 000.0	36DY224F015BF2A	2.000 x 5.625 (51.0 x 143.0)	6.7	23.6
470 000.0	36DY474F015CF2A	2.500 x 5.625 (64.0 x 143.0)	4.2	34.0
680 000.0	36DY684F015DF2A	3.000 x 5.625 (76.0 x 143.0)	4.1	38.4
25 WV_{DC} AT +85 °C, SURGE = 30 V				
18 000.0	36DY183F025AM2A	1.375 x 2.625 (35.0 x 67.0)	25.0	7.12
22 000.0	36DY223F025AB2A	1.375 x 3.125 (35.0 x 79.0)	21.0	8.42
47 000.0	36DY473F025AF2A	1.375 x 5.625 (35.0 x 143.0)	12.6	14.0
33 000.0	36DY333F025BM2A	2.000 x 2.625 (51.0 x 67.0)	15.4	11.5
47 000.0	36DY473F025BB2A	2.000 x 3.125 (51.0 x 79.0)	12.3	13.8
100 000.0	36DY104F025BF2A	2.000 x 5.625 (51.0 x 143.0)	7.2	22.8
120 000.0	36DY124F025CC2A	2.500 x 4.125 (64.0 x 105.0)	6.7	23.8
220 000.0	36DY224F025DE2A	3.000 x 5.125 (76.0 x 130.0)	4.5	35.3
390 000.0	36DY394F025DJ2A	3.000 x 8.625 (76.0 x 219.0)	3.5	49.5
40 WV_{DC} AT +85 °C, SURGE = 50 V				
4700.0	36DY472F040AN2A	1.375 x 1.625 (35.0 x 41.0)	59.0	3.89
10 000.0	36DY103F040AM2A	1.375 x 2.625 (35.0 x 67.0)	28.0	6.84
12 000.0	36DY123F040AB2A	1.375 x 3.125 (35.0 x 79.0)	23.0	8.10
15 000.0	36DY153F040AL2A	1.375 x 3.625 (35.0 x 92.0)	19.4	9.30
10 000.0	36DY103F040BY2A	2.000 x 1.875 (51.0 x 48.0)	30.0	7.40
27 000.0	36DY273F040BB2A	2.000 x 3.125 (51.0 x 79.0)	12.8	13.5
33 000.0	36DY333F040BL2A	2.000 x 3.625 (51.0 x 92.0)	10.9	15.5
39 000.0	36DY393F040BC2A	2.000 x 4.125 (51.0 x 105.0)	9.6	17.4
47 000.0	36DY473F040CB2A	2.500 x 3.125 (64.0 x 79.0)	9.1	18.4
100 000.0	36DY104F040DC2A	3.000 x 4.125 (76.0 x 105.0)	5.4	29.7
8200.0	36DY822F040AM2A	1.375 x 2.625 (35.0 x 67.0)	29.0	6.66
10 000.0	36DY103F040AB2A	1.375 x 3.125 (35.0 x 79.0)	24.0	7.79
15 000.0	36DY153F040AC2A	1.375 x 4.125 (35.0 x 105.0)	18.2	10.1



ELECTRICAL DATA AND ORDERING INFORMATION				
CAPACITANCE (μF)	PART NUMBER	NOMINAL CASE SIZE D x L	MAX. ESR AT 25 °C (mΩ) 120 Hz	MAX. RIPPLE AT +85 °C (A) 120 Hz
50 WV_{DC} AT +85 °C, SURGE = 65 V				
5600.0	36DY562F050AA2A	1.375 x 2.125 (35.0 x 54.0)	40.0	5.25
8200.0	36DY822F050AM2A	1.375 x 2.625 (35.0 x 67.0)	29.0	6.66
10 000.0	36DY103F050AB2A	1.375 x 3.125 (35.0 x 79.0)	24.0	8.60
47 000.0	36DY473F050BF2A	2.000 x 5.625 (51.0 x 143.0)	7.7	22.1
100 000.0	36DY104F050DE2A	3.000 x 5.125 (76.0 x 130.0)	4.8	34.2
180 000.0	36DY184F050DJ2A	3.000 x 8.625 (76.0 x 219.0)	3.6	48.8
60 WV_{DC} AT +85 °C, SURGE = 75 V				
2700.0	36DY272F060AN2A	1.375 x 1.625 (35.0 x 41.0)	69.0	3.62
4700.0	36DY472F060AA2A	1.375 x 2.125 (35.0 x 54.0)	42.0	5.10
8200.0	36DY822F060AB2A	1.375 x 3.125 (35.0 x 79.0)	25.0	7.72
10 000.0	36DY103F060AL2A	1.375 x 3.625 (35.0 x 92.0)	22.0	8.75
15 000.0	36DY153F060BB2A	2.000 x 3.125 (51.0 x 79.0)	13.9	13.0
22 000.0	36DY223F060BL2A	2.000 x 3.625 (51.0 x 92.0)	11.7	15.0
47 000.0	36DY473F060CD2A	2.500 x 4.625 (64.0 x 117.0)	6.6	25.1
100 000.0	36DY104F060DF2A	3.000 x 5.625 (76.0 x 143.0)	4.5	36.7
75 WV_{DC} AT +85 °C, SURGE = 95 V				
1800.0	36DY182F075AN2A	1.375 x 1.625 (35.0 x 41.0)	104.0	2.95
3300.0	36DY332F075AA2A	1.375 x 2.125 (35.0 x 54.0)	62.0	4.19
5600.0	36DY562F075AB2A	1.375 x 3.125 (35.0 x 79.0)	36.0	6.45
6800.0	36DY682F075AL2A	1.375 x 3.625 (35.0 x 92.0)	30.0	7.50
10 000.0	36DY103F075AD2A	1.375 x 4.625 (35.0 x 117.0)	24.0	9.26
12 000.0	36DY123F075BB2A	2.000 x 3.125 (51.0 x 79.0)	18.8	11.1
18 000.0	36DY183F075BC2A	2.000 x 4.125 (51.0 x 105.0)	13.7	14.5
47 000.0	36DY473F075CF2A	2.500 x 5.625 (64.0 x 143.0)	6.7	26.9
47 000.0	36DY473F075DC2A	3.000 x 4.125 (76.0 x 105.0)	8.9	23.2
120 000.0	36DY124F075DJ2A	3.000 x 8.625 (76.0 x 219.0)	5.0	41.5
100 WV_{DC} AT +85 °C, SURGE = 125 V				
1800.0	36DY182F100AM2A	1.375 x 2.625 (35.0 x 67.0)	56.0	4.82
4700.0	36DY472F100AC2A	1.375 x 4.125 (35.0 x 105.0)	32.0	7.68
4700.0	36DY472F100BM2A	2.000 x 2.625 (51.0 x 67.0)	30.0	8.29
10 000.0	36DY103F100BC2A	2.000 x 4.125 (51.0 x 105.0)	16.3	13.3
10 000.0	36DY103F100CB2A	2.500 x 3.125 (64.0 x 79.0)	14.8	14.5
18 000.0	36DY183F100DL2A	3.000 x 3.625 (76.0 x 92.0)	11.2	19.7
33 000.0	36DY333F100DE2A	3.000 x 5.125 (76.0 x 130.0)	7.9	26.7
150 WV_{DC} AT +85 °C, SURGE = 175 V				
2700.0	36DY272F150AF2A	1.375 x 5.625 (35.0 x 143.0)	35.0	6.84
2200.0	36DY222F150BB2A	2.000 x 3.125 (51.0 x 79.0)	57.0	5.22
5600.0	36DY562F150BF2A	2.000 x 5.625 (51.0 x 143.0)	22.0	10.66
10 000.0	36DY103F150CF2A	2.500 x 5.625 (64.0 x 143.0)	12.0	16.43
10 000.0	36DY103F150DC2A	3.000 x 4.125 (76.0 x 105.0)	17.0	13.68
200 WV_{DC} AT +85 °C, SURGE = 250 V				
1000.0	36DY102F200AB2A	1.375 x 3.125 (35.0 x 79.0)	84.0	1.5
1500.0	36DY152F200BM2A	2.000 x 2.625 (51.0 x 67.0)	72.0	4.36
2200.0	36DY222F200BL2A	2.000 x 3.625 (51.0 x 92.0)	49.0	5.97
2700.0	36DY272F200BC2A	2.000 x 4.125 (51.0 x 105.0)	40.0	6.95
3300.0	36DY332F200CB2A	2.500 x 3.125 (64.0 x 79.0)	32.0	8.03
4700.0	36DY472F200CC2A	2.500 x 4.125 (64.0 x 105.0)	22.0	10.73
10 000.0	36DY103F200DE2A	3.000 x 5.125 (76.0 x 130.0)	14.0	16.36



ELECTRICAL DATA AND ORDERING INFORMATION				
CAPACITANCE (μF)	PART NUMBER	NOMINAL CASE SIZE D x L	MAX. ESR AT 25 °C (mΩ) 120 Hz	MAX. RIPPLE AT +85 °C (A) 120 Hz
250 WV_{DC} AT +85 °C, SURGE = 300 V				
560.0	36DY561F250AM2A	1.375 x 2.625 (35.0 x 67.0)	132.0	2.55
1000.0	36DY102F250AL2A	1.375 x 3.625 (35.0 x 92.0)	74.0	3.89
2700.0	36DY272F250BD2A	2.000 x 4.625 (51.0 x 117.0)	34.0	7.90
3300.0	36DY332F250BF2A	2.000 x 5.625 (51.0 x 143.0)	29.0	9.44
2700.0	36DY272F250CB2A	2.500 x 3.125 (64.0 x 79.0)	34.0	7.79
4700.0	36DY472F250DL2A	3.000 x 3.625 (76.0 x 92.0)	24.0	10.99
10 000.0	36DY103F250DF2A	3.000 x 5.625 (76.0 x 143.0)	11.0	19.14
350 WV_{DC} AT +85 °C, SURGE = 400 V				
470.0	36DY471F350AB2A	1.375 x 3.125 (35.0 x 79.0)	272.0	1.91
1000.0	36DY102F350AF2A	1.375 x 5.625 (35.0 x 143.0)	128.0	3.58
1000.0	36DY102F350BL2A	2.000 x 3.625 (51.0 x 92.0)	136.0	3.58
1800.0	36DY182F350BF2A	2.000 x 5.625 (51.0 x 143.0)	76.0	5.73
3300.0	36DY332F350DC2A	3.000 x 4.125 (76.0 x 105.0)	44.0	8.50
4700.0	36DY472F350DE2A	3.000 x 5.125 (76.0 x 130.0)	31.0	10.99
400 WV_{DC} AT +85 °C, SURGE = 450 V				
270.0	36DY271F400AM2A	1.375 x 2.625 (35.0 x 67.0)	429.0	1.41
680.0	36DY681F400AE2A	1.375 x 5.125 (35.0 x 130.0)	170.0	2.98
1000.0	36DY102F400BC2A	2.000 x 4.125 (51.0 x 105.0)	123.0	3.96
2200.0	36DY222F400CD2A	2.500 x 4.625 (64.0 x 117.0)	55.0	7.09
2700.0	36DY272F400DC2A	3.000 x 4.125 (76.0 x 105.0)	48.0	8.14
6800.0	36DY682F400DJ2A	3.000 x 8.625 (76.0 x 219.0)	19.0	17.36
450 WV_{DC} AT +85 °C, SURGE = 525 V				
330.0	36DY331F450AB2A	1.375 x 3.125 (35.0 x 79.0)	317.0	1.77
680.0	36DY681F450AE2A	1.375 x 5.125 (35.0 x 130.0)	164.0	3.13
1000.0	36DY102F450BC2A	2.000 x 4.125 (51.0 x 105.0)	113.0	4.13
2700.0	36DY272F450CF2A	2.500 x 5.625 (64.0 x 143.0)	42.0	8.78
3300.0	36DY332F450DD2A	3.000 x 4.625 (76.0 x 117.0)	36.0	10.20
5600.0	36DY562F450DJ2A	3.000 x 8.625 (76.0 x 219.0)	21.0	16.51

Statements about product lifetime are based on calculations and internal testing. They should only be interpreted as estimations. Also due to external factors, the lifetime in the field application may deviate from the calculated lifetime. In general, nothing stated herein shall be construed as a guarantee of durability.



Disclaimer

ALL PRODUCT, PRODUCT SPECIFICATIONS AND DATA ARE SUBJECT TO CHANGE WITHOUT NOTICE TO IMPROVE RELIABILITY, FUNCTION OR DESIGN OR OTHERWISE.

Vishay Intertechnology, Inc., its affiliates, agents, and employees, and all persons acting on its or their behalf (collectively, "Vishay"), disclaim any and all liability for any errors, inaccuracies or incompleteness contained in any datasheet or in any other disclosure relating to any product.

Vishay makes no warranty, representation or guarantee regarding the suitability of the products for any particular purpose or the continuing production of any product. To the maximum extent permitted by applicable law, Vishay disclaims (i) any and all liability arising out of the application or use of any product, (ii) any and all liability, including without limitation special, consequential or incidental damages, and (iii) any and all implied warranties, including warranties of fitness for particular purpose, non-infringement and merchantability.

Statements regarding the suitability of products for certain types of applications are based on Vishay's knowledge of typical requirements that are often placed on Vishay products in generic applications. Such statements are not binding statements about the suitability of products for a particular application. It is the customer's responsibility to validate that a particular product with the properties described in the product specification is suitable for use in a particular application. Parameters provided in datasheets and / or specifications may vary in different applications and performance may vary over time. All operating parameters, including typical parameters, must be validated for each customer application by the customer's technical experts. Product specifications do not expand or otherwise modify Vishay's terms and conditions of purchase, including but not limited to the warranty expressed therein.

Except as expressly indicated in writing, Vishay products are not designed for use in medical, life-saving, or life-sustaining applications or for any other application in which the failure of the Vishay product could result in personal injury or death. Customers using or selling Vishay products not expressly indicated for use in such applications do so at their own risk. Please contact authorized Vishay personnel to obtain written terms and conditions regarding products designed for such applications.

No license, express or implied, by estoppel or otherwise, to any intellectual property rights is granted by this document or by any conduct of Vishay. Product names and markings noted herein may be trademarks of their respective owners.

Компания «Океан Электроники» предлагает заключение долгосрочных отношений при поставках импортных электронных компонентов на взаимовыгодных условиях!

Наши преимущества:

- Поставка оригинальных импортных электронных компонентов напрямую с производств Америки, Европы и Азии, а так же с крупнейших складов мира;
- Широкая линейка поставок активных и пассивных импортных электронных компонентов (более 30 млн. наименований);
- Поставка сложных, дефицитных, либо снятых с производства позиций;
- Оперативные сроки поставки под заказ (от 5 рабочих дней);
- Экспресс доставка в любую точку России;
- Помощь Конструкторского Отдела и консультации квалифицированных инженеров;
- Техническая поддержка проекта, помощь в подборе аналогов, поставка прототипов;
- Поставка электронных компонентов под контролем ВП;
- Система менеджмента качества сертифицирована по Международному стандарту ISO 9001;
- При необходимости вся продукция военного и аэрокосмического назначения проходит испытания и сертификацию в лаборатории (по согласованию с заказчиком);
- Поставка специализированных компонентов военного и аэрокосмического уровня качества (Xilinx, Altera, Analog Devices, Intersil, Interpoint, Microsemi, Actel, Aeroflex, Peregrine, VPT, Syfer, Eurofarad, Texas Instruments, MS Kennedy, Miteq, Cobham, E2V, MA-COM, Hittite, Mini-Circuits, General Dynamics и др.);

Компания «Океан Электроники» является официальным дистрибьютором и эксклюзивным представителем в России одного из крупнейших производителей разъемов военного и аэрокосмического назначения «JONHON», а так же официальным дистрибьютором и эксклюзивным представителем в России производителя высокотехнологичных и надежных решений для передачи СВЧ сигналов «FORSTAR».



JONHON

«JONHON» (основан в 1970 г.)

Разъемы специального, военного и аэрокосмического назначения:

(Применяются в военной, авиационной, аэрокосмической, морской, железнодорожной, горно- и нефтедобывающей отраслях промышленности)

«FORSTAR» (основан в 1998 г.)

ВЧ соединители, коаксиальные кабели,
кабельные сборки и микроволновые компоненты:

(Применяются в телекоммуникациях гражданского и специального назначения, в средствах связи, РЛС, а так же военной, авиационной и аэрокосмической отраслях промышленности).



Телефон: 8 (812) 309-75-97 (многоканальный)

Факс: 8 (812) 320-03-32

Электронная почта: ocean@oceanchips.ru

Web: <http://oceanchips.ru/>

Адрес: 198099, г. Санкт-Петербург, ул. Калинина, д. 2, корп. 4, лит. А