



VLV Series

Features

- 12.5 φ ~ 16 φ, 105°C, 5,000 hours assured
- Suitable for automotive application
- Peak acceleration: 50G / 30G
- RoHS Compliance



Marking color: Black

Specifications

Items	Performance																														
Category Temperature Range	-55 ~ +105°C																														
Capacitance Tolerance	±20% (at 120Hz, 20°C)																														
Leakage Current (at 20°C)	I = 0.01CV or 3 (μA) whichever is greater (after 2 minutes) Where, C = rated capacitance in μF V = rated DC working voltage in V																														
Dissipation Factor (Tanδ at 120Hz, 20°C)	<table border="1"> <thead> <tr> <th>Rated Voltage</th> <th>6.3</th> <th>10</th> <th>16</th> <th>25</th> <th>35</th> <th>50</th> <th>63</th> <th>80</th> <th>100</th> </tr> </thead> <tbody> <tr> <td>Tanδ (max)</td> <td>0.30</td> <td>0.26</td> <td>0.22</td> <td>0.16</td> <td>0.13</td> <td>0.10</td> <td>0.08</td> <td>0.08</td> <td>0.07</td> </tr> </tbody> </table> <p>When the capacitance exceeds 1,000μF, 0.02 shall be added every 1,000μF increase.</p>	Rated Voltage	6.3	10	16	25	35	50	63	80	100	Tanδ (max)	0.30	0.26	0.22	0.16	0.13	0.10	0.08	0.08	0.07										
Rated Voltage	6.3	10	16	25	35	50	63	80	100																						
Tanδ (max)	0.30	0.26	0.22	0.16	0.13	0.10	0.08	0.08	0.07																						
Low Temperature Characteristics (at 120Hz)	<p>Impedance ratio shall not exceed the values given in the table below.</p> <table border="1"> <thead> <tr> <th>Rated Voltage</th> <th>6.3</th> <th>10</th> <th>16</th> <th>25</th> <th>35</th> <th>50</th> <th>63</th> <th>80</th> <th>100</th> </tr> </thead> <tbody> <tr> <td>Impedance Ratio</td> <td>Z(-25°C)/Z(+20°C)</td> <td>4</td> <td>3</td> <td>2</td> <td>2</td> <td>2</td> <td>2</td> <td>2</td> <td>2</td> </tr> <tr> <td></td> <td>Z(-55°C)/Z(+20°C)</td> <td>8</td> <td>5</td> <td>4</td> <td>3</td> <td>3</td> <td>3</td> <td>3</td> <td>3</td> </tr> </tbody> </table>	Rated Voltage	6.3	10	16	25	35	50	63	80	100	Impedance Ratio	Z(-25°C)/Z(+20°C)	4	3	2	2	2	2	2	2		Z(-55°C)/Z(+20°C)	8	5	4	3	3	3	3	3
Rated Voltage	6.3	10	16	25	35	50	63	80	100																						
Impedance Ratio	Z(-25°C)/Z(+20°C)	4	3	2	2	2	2	2	2																						
	Z(-55°C)/Z(+20°C)	8	5	4	3	3	3	3	3																						
Endurance	<table border="1"> <thead> <tr> <th>Test Time</th> <th>5,000 Hrs</th> </tr> </thead> <tbody> <tr> <td>Capacitance Change</td> <td>Within ±30% of initial value</td> </tr> <tr> <td>Dissipation Factor</td> <td>Less than 300% of specified value</td> </tr> <tr> <td>Leakage Current</td> <td>Within specified value</td> </tr> </tbody> </table> <p>* The above Specifications shall be satisfied when the capacitors are restored to 20°C after the rated voltage applied for 5,000 hours at 105°C.</p>	Test Time	5,000 Hrs	Capacitance Change	Within ±30% of initial value	Dissipation Factor	Less than 300% of specified value	Leakage Current	Within specified value																						
Test Time	5,000 Hrs																														
Capacitance Change	Within ±30% of initial value																														
Dissipation Factor	Less than 300% of specified value																														
Leakage Current	Within specified value																														
Shelf Life Test	<table border="1"> <thead> <tr> <th>Test Time</th> <th>1,000 Hrs</th> </tr> </thead> <tbody> <tr> <td>Capacitance Change</td> <td>Within ±30% of initial value</td> </tr> <tr> <td>Dissipation Factor</td> <td>Less than 300% of specified value</td> </tr> <tr> <td>Leakage Current</td> <td>Within specified value</td> </tr> </tbody> </table> <p>* The above Specifications shall be satisfied when the capacitors are restored to 20°C after exposing them for 1,000 hours at 105°C without voltage applied.</p>	Test Time	1,000 Hrs	Capacitance Change	Within ±30% of initial value	Dissipation Factor	Less than 300% of specified value	Leakage Current	Within specified value																						
Test Time	1,000 Hrs																														
Capacitance Change	Within ±30% of initial value																														
Dissipation Factor	Less than 300% of specified value																														
Leakage Current	Within specified value																														
Ripple Current & Frequency Multipliers	<table border="1"> <thead> <tr> <th>Frequency(Hz)</th> <th>50, 60</th> <th>120</th> <th>1k</th> <th>10k up</th> </tr> </thead> <tbody> <tr> <td>Multiplier</td> <td>0.60</td> <td>0.70</td> <td>0.85</td> <td>1.0</td> </tr> </tbody> </table>	Frequency(Hz)	50, 60	120	1k	10k up	Multiplier	0.60	0.70	0.85	1.0																				
Frequency(Hz)	50, 60	120	1k	10k up																											
Multiplier	0.60	0.70	0.85	1.0																											
Vibration	<p>Peak acceleration: 50G Peak to peak amplitude: 1.5mm Frequency: 5 to 2,000 Hz reciprocation for 20 min. Direction and duration of vibration: 3 orthogonal directions mutually each for 4 Hrs.</p>																														

Diagram of Dimensions

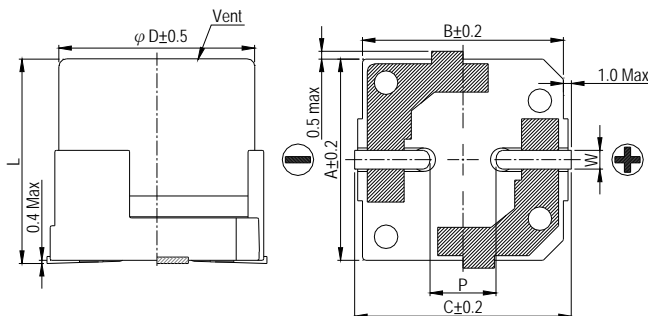

Lead Spacing and Diameter						Unit: mm
φ D	L	A	B	C	W	P ± 0.2
12.5	13.5 ± 0.5	13.0	13.5	14.5	1.1 ~ 1.4	4.4
12.5	16 ± 0.5	13.0	13.5	14.5	1.1 ~ 1.4	4.4
16	16.5 ± 0.5	16.5	17.0	18.2	1.1 ~ 1.4	6.4

## Marking

$\phi D \geq 12.5\text{mm}$



Dimension:  $\phi D \times L(\text{mm})$

Ripple Current: mA/rms at 100k Hz, 105°C

Impedance:  $\Omega$  at 100k Hz, 20°C

## Dimension & Permissible Ripple Current

$\mu\text{F}$	V. DC Contents	6.3V (0J)			10V (1A)			16V (1C)			25V (1E)			35V (1V)			50V (1H)				
		$\phi D \times L$	Imp.	mA	$\phi D \times L$	Imp.	mA	$\phi D \times L$	Imp.	mA	$\phi D \times L$	Imp.	mA	$\phi D \times L$	Imp.	mA	$\phi D \times L$	Imp.	mA		
330	331															12.5×13.5	0.066	850	12.5×13.5	0.11	700
470	471															12.5×16	0.058	950	16×16.5	0.070	1,100
680	681															12.5×16	0.058	950	16×16.5	0.070	1,100
1,000	102							12.5×13.5	0.066	850	12.5×16	0.058	950	16×16.5	0.052	1,300					
1,500	152				12.5×13.5	0.066	850	12.5×16	0.058	950	16×16.5	0.052	1,300								
2,200	222	12.5×13.5	0.066	850	12.5×16	0.058	950	16×16.5	0.052	1,300	16×16.5	0.052	1,300								
3,300	332	12.5×16	0.058	950	16×16.5	0.052	1,300	16×16.5	0.052	1,300											
4,700	472	16×16.5	0.052	1,300	16×16.5	0.052	1,300														

$\mu\text{F}$	V. DC Contents	63V (1J)			80V (1K)			100V (2A)		
		$\phi D \times L$	Imp.	mA	$\phi D \times L$	Imp.	mA	$\phi D \times L$	Imp.	mA
100	101							12.5×13.5	0.32	450
150	151	12.5×13.5	0.140	700	12.5×13.5	0.32	450	12.5×16	0.26	550
220	221	12.5×13.5	0.140	700	12.5×16	0.26	550	16×16.5	0.17	650
330	331	16×16.5	0.080	900	16×16.5	0.17	650			
470	471	16×16.5	0.080	900						

Компания «Океан Электроники» предлагает заключение долгосрочных отношений при поставках импортных электронных компонентов на взаимовыгодных условиях!

Наши преимущества:

- Поставка оригинальных импортных электронных компонентов напрямую с производств Америки, Европы и Азии, а так же с крупнейших складов мира;
- Широкая линейка поставок активных и пассивных импортных электронных компонентов (более 30 млн. наименований);
- Поставка сложных, дефицитных, либо снятых с производства позиций;
- Оперативные сроки поставки под заказ (от 5 рабочих дней);
- Экспресс доставка в любую точку России;
- Помощь Конструкторского Отдела и консультации квалифицированных инженеров;
- Техническая поддержка проекта, помощь в подборе аналогов, поставка прототипов;
- Поставка электронных компонентов под контролем ВП;
- Система менеджмента качества сертифицирована по Международному стандарту ISO 9001;
- При необходимости вся продукция военного и аэрокосмического назначения проходит испытания и сертификацию в лаборатории (по согласованию с заказчиком);
- Поставка специализированных компонентов военного и аэрокосмического уровня качества (Xilinx, Altera, Analog Devices, Intersil, Interpoint, Microsemi, Actel, Aeroflex, Peregrine, VPT, Syfer, Eurofarad, Texas Instruments, MS Kennedy, Miteq, Cobham, E2V, MA-COM, Hittite, Mini-Circuits, General Dynamics и др.);

Компания «Океан Электроники» является официальным дистрибьютором и эксклюзивным представителем в России одного из крупнейших производителей разъемов военного и аэрокосмического назначения «JONHON», а так же официальным дистрибьютором и эксклюзивным представителем в России производителя высокотехнологичных и надежных решений для передачи СВЧ сигналов «FORSTAR».



## JONHON

«JONHON» (основан в 1970 г.)

Разъемы специального, военного и аэрокосмического назначения:

(Применяются в военной, авиационной, аэрокосмической, морской, железнодорожной, горно- и нефтедобывающей отраслях промышленности)

«FORSTAR» (основан в 1998 г.)

ВЧ соединители, коаксиальные кабели,  
кабельные сборки и микроволновые компоненты:

(Применяются в телекоммуникациях гражданского и специального назначения, в средствах связи, РЛС, а так же военной, авиационной и аэрокосмической отраслях промышленности).



Телефон: 8 (812) 309-75-97 (многоканальный)

Факс: 8 (812) 320-03-32

Электронная почта: [ocean@oceanchips.ru](mailto:ocean@oceanchips.ru)

Web: <http://oceanchips.ru/>

Адрес: 198099, г. Санкт-Петербург, ул. Калинина, д. 2, корп. 4, лит. А