



ON Semiconductor®

User Guide for
FEBFL77905_L83L08A
FEBFL77905_L83H08A

Evaluation Board
8W AC LED Driver

Featured Fairchild Product:
FL77905

*Direct questions or comments
about this evaluation board to:
“Worldwide Direct Support”*

Fairchild Semiconductor.com



Table of Contents

1. Introduction.....	3
1.1. General Description of FL77905MX.....	3
1.2. Controller Features.....	3
1.3. Controller Internal Block Diagram	4
2. Evaluation Board Test Outline.....	5
3. Evaluation Board Specifications.....	6
4. Evaluation Board Operating Temperature	7
5. Evaluation Board Bill of Materials (BOM)	9
6. Evaluation Board	10
6.1. Evaluation Board Schematic.....	10
6.2. Key Performance Measurements	11
6.3. Startup	13
6.4. Normal Operation	14
6.5. Dimming Operation & Performance.....	15
6.6. Electromagnetic Interference	17
6.7. Surge Test	17
7. Revision History	18



This user guide supports the evaluation kit for the FL77905. It should be used in conjunction with the FL77905 datasheet as well as Fairchild's application notes and technical support team. Please visit Fairchild's website at www.fairchildsemi.com.

1. Introduction

This document describes a direct AC line LED driver with a minimal number of external components. The input voltage ranges of the LED driver board are classed as low-line application for $108 V_{AC} \sim 132 V_{AC}$, and high line application for $198 V_{AC} \sim 242 V_{AC}$. With a single DC output, constant current depends on the R_{cs} value. This document contains a general description of the FL77905, the normal configuration specification, schematic, bill of materials, and typical operating characteristics.

1.1. General Description of FL77905MX

The FL77905 is a direct AC line LED driver with a minimal number of external RC passive components. In normal configuration, one resistor is to adjust LED power, and one capacitor is to provide a stable voltage to an internal biasing shunt regulator.

The FL77905 provides phase-cut dimming with wide dimming range, smooth dimming control and good dimmer compatibility. It achieves the high efficiency with high PF and low THD which makes the FL77905 suitable for high-efficiency LED lighting systems. The FL77905 has a dedicated DIM pin which can be used with analog or digital PWM dimming.

High wattage design of the FL77905 can be implemented with multiple IC embedded in parallel for street lighting and down lighting applications.

1.2. Controller Features

- The simplest Direct AC LED Driver with Only Two External RC Passive Component
- Wide AC Input Range: $90 \sim 305 V_{AC}$
- Four Integrated High-Voltage LED Constant Current Sinks of up to 75 mA (RMS) Capability
- TRIAC Dimmable (Leading/Trailing Edge)
- Analog/Digital PWM Dimming Function
- Rheostat Dimmable
- High Power Factor (above 0.98 in normal configuration)
- Adjustable LED Power with an External Current Sense Resistor
- Low Harmonic Content (THD under 20% in normal configuration)
- SOP 8LD Package
- Flexible LED Forward Voltage Configuration
- Power Scalability with Multiple Driver ICs
- Over-Temperature Protection (OTP)



1.3. Controller Internal Block Diagram

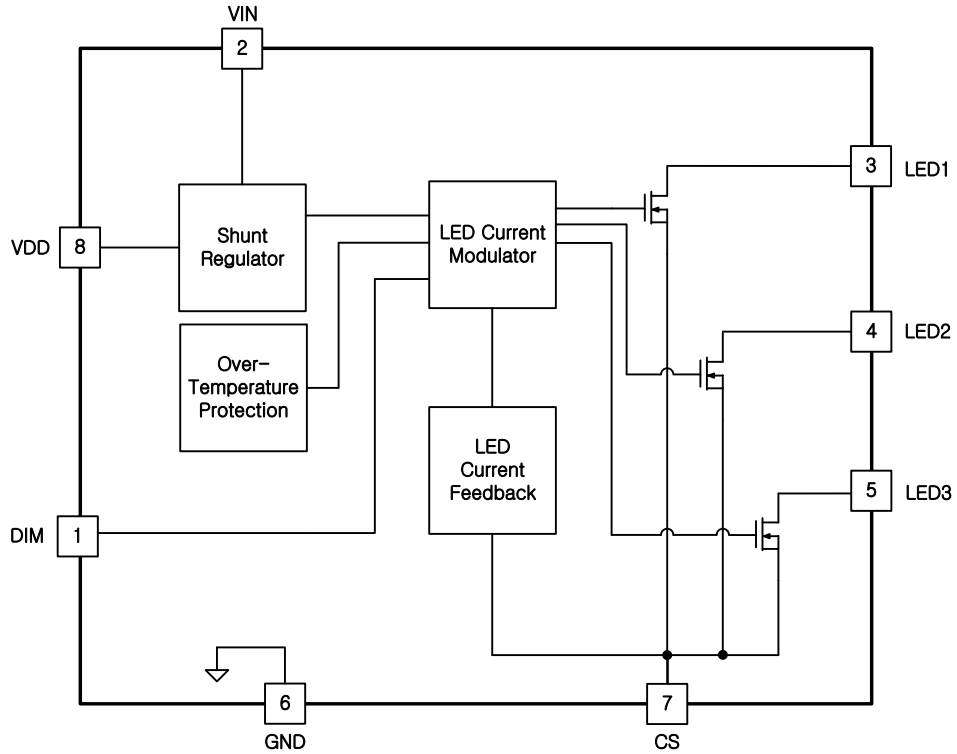

大

Figure 1. Simplified FL77904 Block Diagram



2. Evaluation Board Test Outline

Table 1. Evaluation Board Test Condition & Equipment List

Evaluation Board #	FEBFL77905_L83L08A	Low-Line, 8 W
	FEBFL77905_L83H08A	High-Line, 8 W
Test Date	October- 2016	
Test Equipment	AC Source: 6800 Series Oscilloscope: LeCroy 24MXs-B Power Analyzer: Chroma 6630 Thermal imager: Fluke Ti110 Light measurement: INVENTFINE CMS-8000 Photo Sensor for Flicker Index: ADMESY LM-AST-CC	
Test Items	<ol style="list-style-type: none">1. Startup Performance2. Normal Operation3. Efficacy4. Flicker Index5. Power Factor6. Total Harmonic Distortion(THD)7. Conduction EMI	



3. Evaluation Board Specifications

Table 2. Evaluation Board Specifications

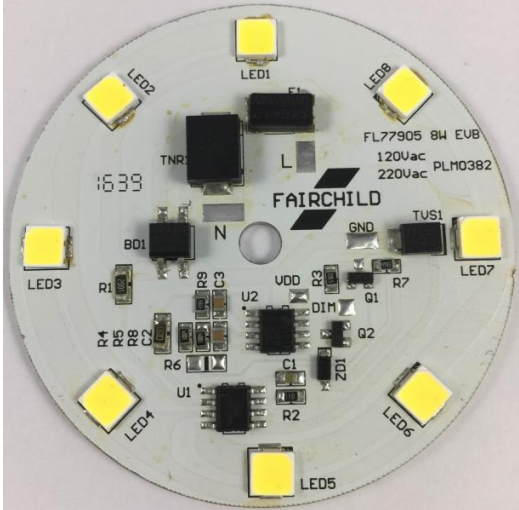
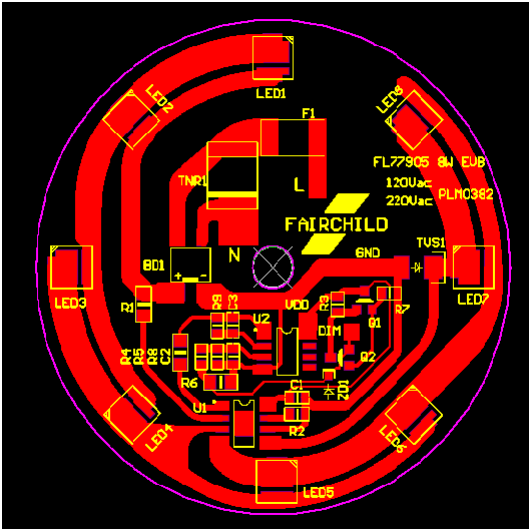
<p>EVB PHOTO</p>	
<p>PCB</p>	
<p>Diameter</p>	<p>60 mm</p>
<p>Material</p>	<p>Metal</p>
<p>Thickness</p>	<p>1.6 t</p>
<p>Input</p>	<p>Low-Line: 108 ~ 132 V_{AC} , High-Line: 198 ~ 242 V_{AC}</p>



4. Evaluation Board Operating Temperature

Table 3. Evaluation Board Operating Temperature

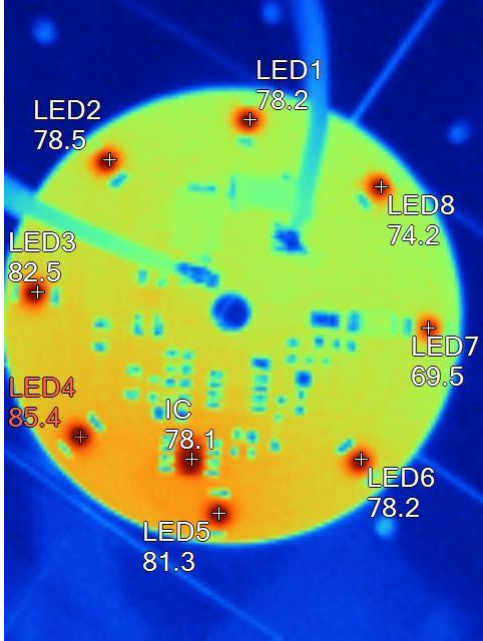
	
Test Condition	120 V _{AC} , 30min, Room temperature. With Heat sink: 120 mm * 152 mm * 11 mm
Spot	LED1: 78.2°C LED2: 78.5°C LED3: 82.5°C LED4: 85.4°C LED5: 81.3°C LED6: 78.2°C LED7: 69.5°C LED8: 74.2°C IC: 78.1°C

Temperatures on all components at low line evaluation board are less than 86°C. The IC's temperature is lower than 79°C. Measured temperature can be changed by dimension of Heat sink.

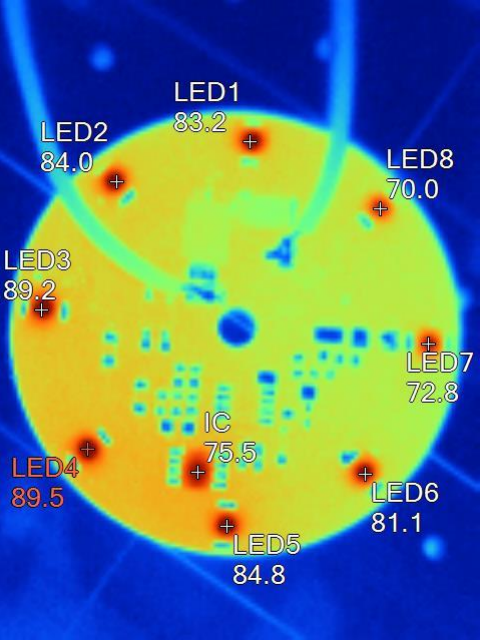

Table 4. Evaluation Board Operating Temperature

	
Test Condition	220 V _{AC} , 30min, Room temperature. With Heat sink: 120 mm * 152 mm * 11 mm
Spot	LED1: 83.2°C LED2: 84.0°C LED3: 89.2°C LED4: 89.5°C LED5: 84.8°C LED6: 81.1°C LED7: 72.8°C LED8: 70.0°C IC: 75.5°C

Temperatures on all components at high line evaluation board are less than 90°C. The IC's temperature is lower than 76°C. Measured temperature can be changed with dimension of heat sink.



5. Evaluation Board Bill of Materials (BOM)

No.	Description	Specification	Type	Location No.	Qty.	Vender	Remark
Common Parts							
1	CHIP-RES	11 Ω	0805	R2	1		Low line
	CHIP-RES	20 Ω	0805	R2	1		High line
2	CHIP-RES	576 Ω	0805	R3	1		
3	CHIP-RES	470 kΩ	0805	R7	1		
4	CHIP-RES	1 M Ω	0805	R5, R8	2		
5	CHIP-RES	4.7 M Ω	0805	R9	1		
6	CHIP-RES	0 Ω	1206	R4	1		
7	CHIP-RES	2 kΩ	1206	R1	1		
8	CHIP- CAP	15 nF / 25 V	0805	C2, C3	2		
9	CHIP- CAP	0.1 μF / 25 V	0805	C1	1		
10	MMBT290A	SOT-23		Q1, Q2	2	Fairchild	
11	LM258AM	MDIP 8L		U2	1	Fairchild	
12	Bridge Diode	MB6S (0.5 A 600 V)		BD1	1	Fairchild	
13	Varistor	TVB7S221KR	Size3225	TNR1	1		Low line
	Varistor	TVB7S391KR	Size3225	TNR1	1		High line
14	SMD LED	32VF 42 mA	5250	LED 1~8	8	LGIT	Low line
	SMD LED	65.4VF 20 mA	5250	LED 1~8	8	LGIT	High line
15	FUSE	2 A 250 V _{AC} MF2410F1.000TM	SMD	F1	1		
16	IC	FL77905MX	SOIC 8L	U1	1	Fairchild	
17	TVS DIODE	SMBJ100CA	DO214AA(SMB)	TVS1	1	Fairchild	
18	Zener	MMSZ5241B 11V	SOD-123 2L	ZD1	1	Fairchild	
19	PCB0382 V2	60Φ	Metal	PCB	1		



6. Evaluation Board

6.1. Evaluation Board Schematic

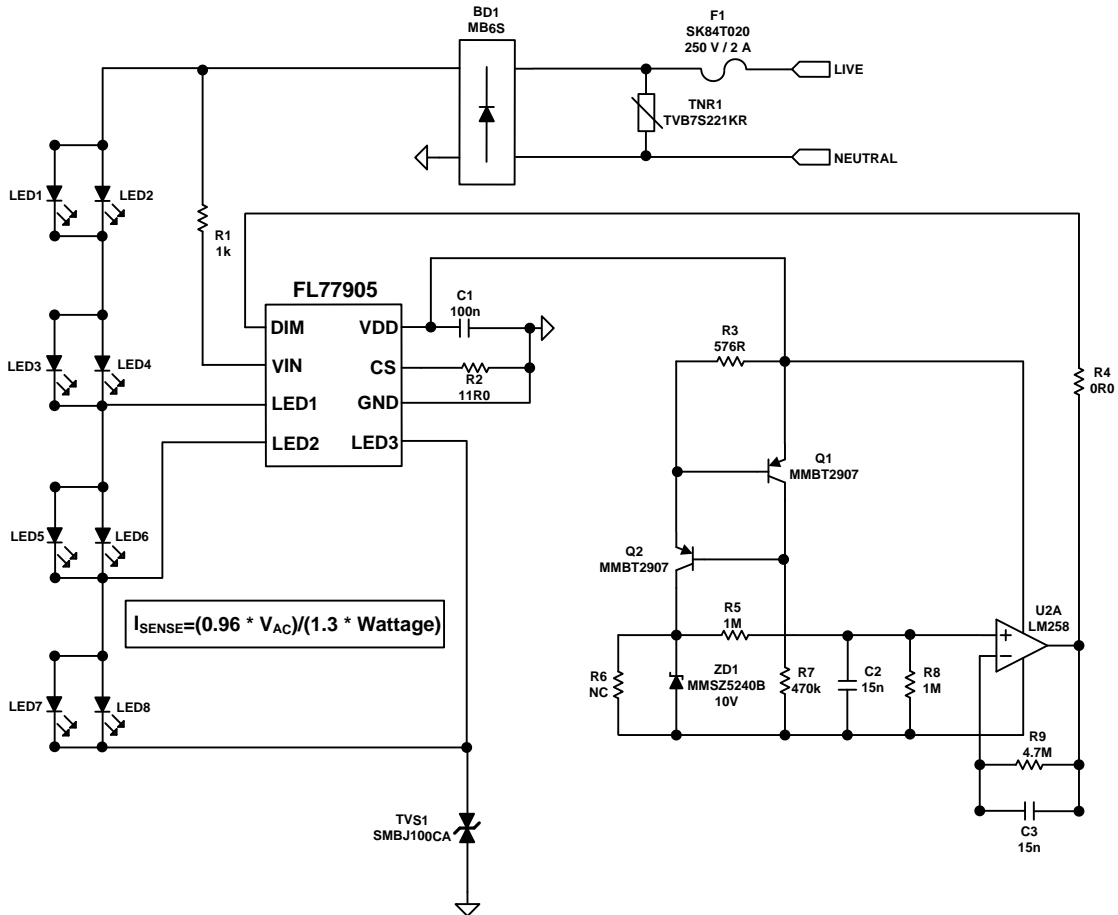

Figure 2. Typical Application Circuit of the 8 W Evaluation Board

Table 5. Evaluation Board Circuit Parameters for High-Line without SVF

Parameter	Value	Unit
Evaluation Board #	FEBFL77905_L83L08A (Low Line)	
	FEBFL77905_L83H08A (High Line)	
Input Voltage	108 ~ 132 (Low Line)	V _{AC}
	198 ~ 242 (High Line)	V _{AC}
Output Power	8	W
LED		



CCT	If(mA)	Vf(V)	CCT	If(mA)	Vf(V)
5700K(G)	42 (Typ.)	32	5700K(G)	42 (Typ.)	32
5700K(G)	20 (Typ.)	65.4	5700K(G)	20 (Typ.)	65.4

6.2. Key Performance Measurements

Table 6. Key Performance Measurements for Low-Line EVB

Input Condition	50 Hz			60 Hz		
	108 V _{AC}	120 V _{AC}	132 V _{AC}	108 V _{AC}	120 V _{AC}	132 V _{AC}
Power Factor	0.978	0.985	0.988	0.978	0.985	0.988
THD (%)	21.18	17.21	15.48	21.36	17.49	15.49
Pin (W)	6.65	8.03	9.27	6.66	8.01	9.26
IIN.RMS (A)	0.061	0.067	0.07	0.062	0.067	0.07
Lumen (lm)	599.7	677.5	736.8	599.5	676.5	735.7
Efficacy(lm/W)	90.9	88.2	84.2	91.0	88.2	84.3
Flicker Index	0.39	0.36	0.34	0.39	0.36	0.34

Table 6 shows the key performance measurements result for low line evaluation board from 108 ~ 132 V_{AC} at 50 Hz / 60 Hz. Power factor has enough margin from 0.9 and THD is less than 22% at the input voltage range from 108 to 132 V_{AC}. Measured Lumen can be changed by test environment such as measurement equipment type, standard sample for equipment calibration and integrating sphere type.

**Table 7. Key Performance Measurements for High-Line EVB**

Input Condition	50 Hz			60 Hz		
	198 V _{AC}	220 V _{AC}	242 V _{AC}	198 V _{AC}	220 V _{AC}	242 V _{AC}
Power Factor	0.984	0.988	0.990	0.984	0.988	0.990
THD (%)	18.12	15.32	14.28	18.20	15.33	14.28
Pin (W)	7.03	8.45	9.81	7.00	8.42	9.79
IIN.RMS (A)	0.036	0.038	0.041	0.036	0.038	0.040
Lumen (lm)	605	707.3	773.3	606.1	707.1	773.1
Efficacy(lm/W)	86.1	83.7	78.8	86.6	84.0	79.0
Flicker Index	0.37	0.35	0.32	0.37	0.35	0.32

Table 7 shows the key performance measurements result for high line evaluation board from 198 ~ 242 V_{AC} at 50 Hz / 60 Hz. Power factor has enough margin from 0.9 and THD is less than 19% at the input voltage range from 108 to 132 V_{AC}. Measured Lumen can be changed by test environment such as measurement equipment type, standard sample for equipment calibration and integrating sphere type.



6.3. Startup

Table 8. Startup Waveform according to Variable Input Voltage and Frequency

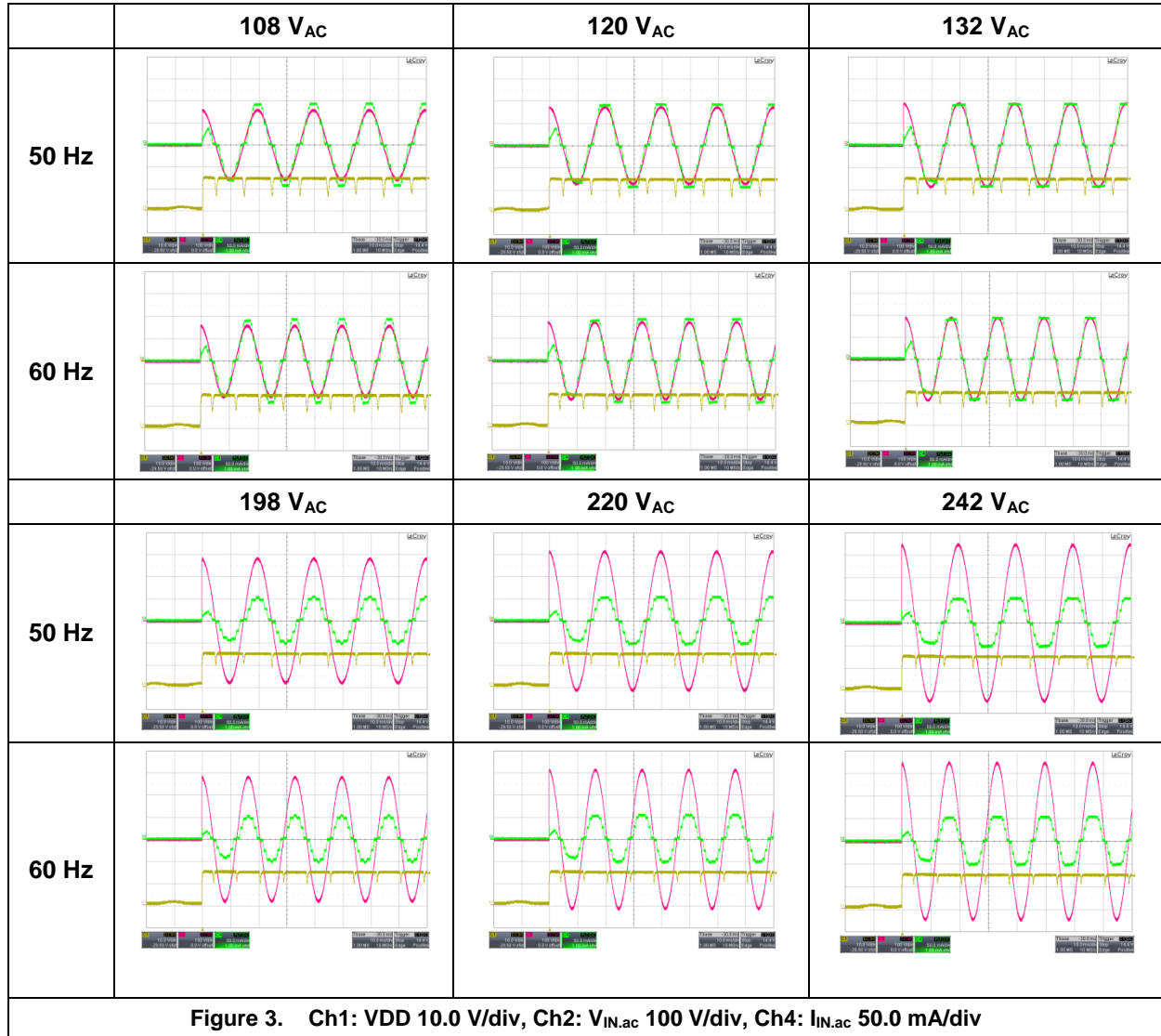

Table 8 shows overall startup performance at each line input voltage with 50 / 60 Hz. Input current flows immediately when input voltage is applied.



6.4. Normal Operation

Table 9. Normal Operation Waveform according to Variable Input Voltage and Frequency

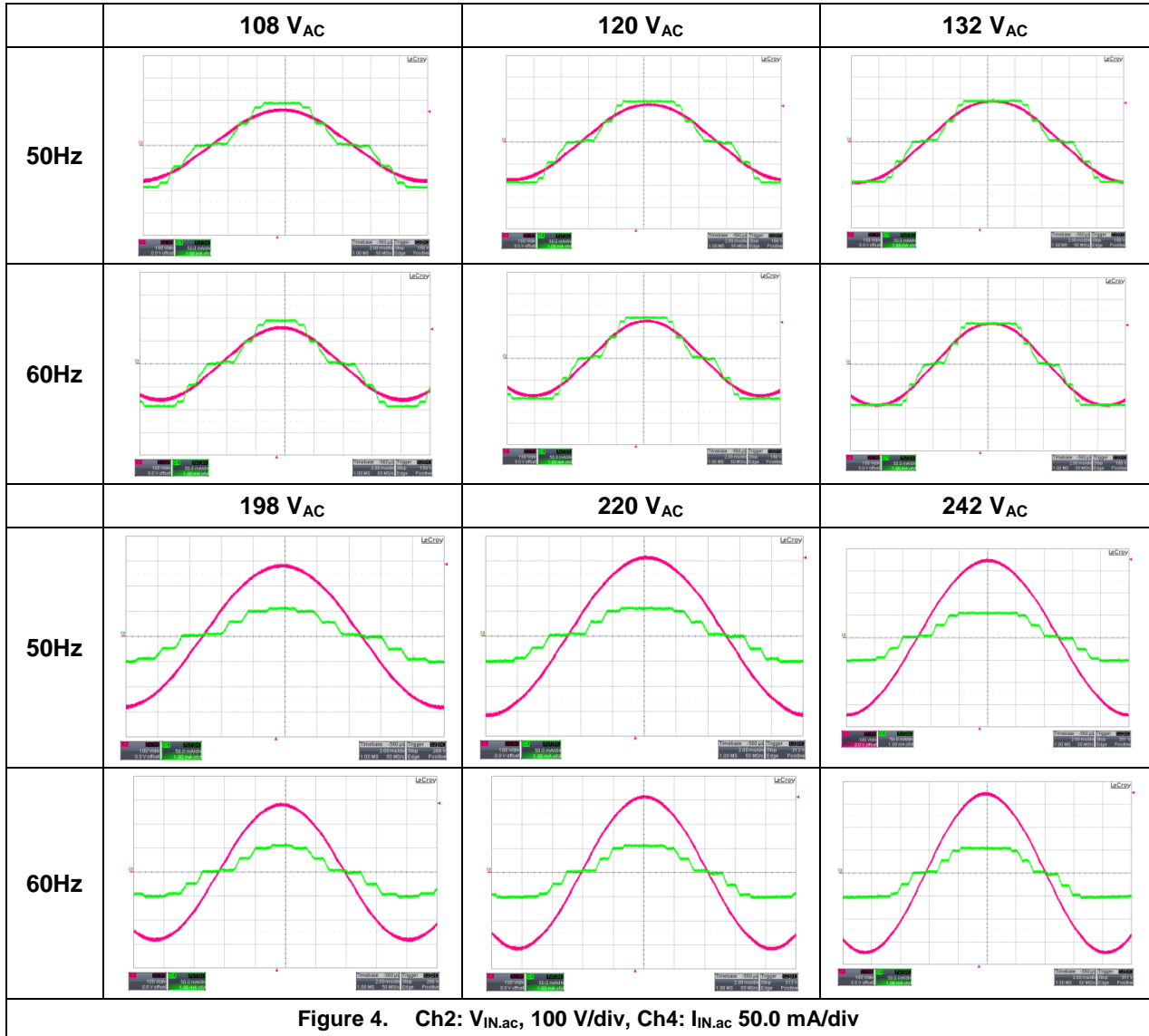
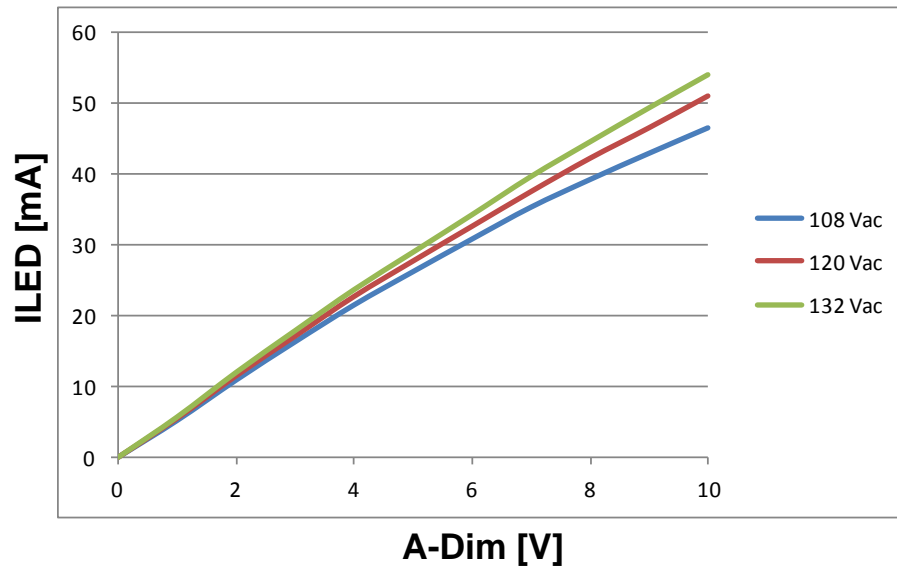
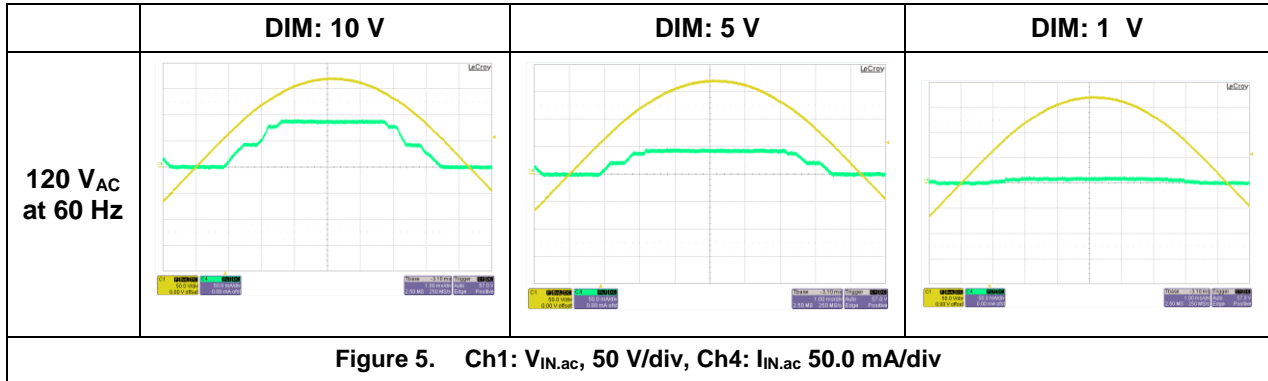

Table 9 shows overall normal operation performance at each line input voltage with 50 / 60 Hz. When input voltage is higher than all string LED forward voltage, LED 3 pin can be conducted and its time depends on input voltage and line frequency.



6.5. Dimming Operation & Performance

Table 10. Dimming Operation Waveform at 120 V_{AC} Input Voltage



FL77905 analog dimming function can be implemented with a few external components. The LED current at the rated line voltage can be adjusted within the range of 0% to 100% of the nominal current value from 0 to 10 V A-DIM signals at DIM pin



Table 11. Dimming Operation Waveform at 220 V_{AC} Input Voltage

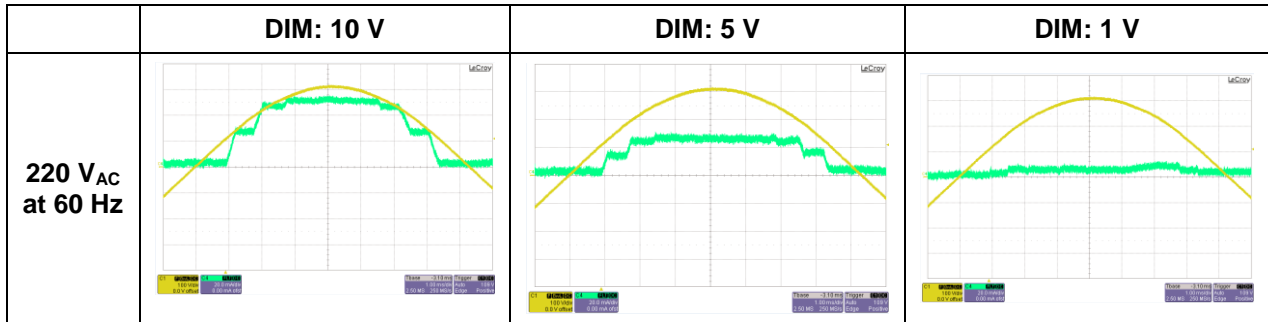
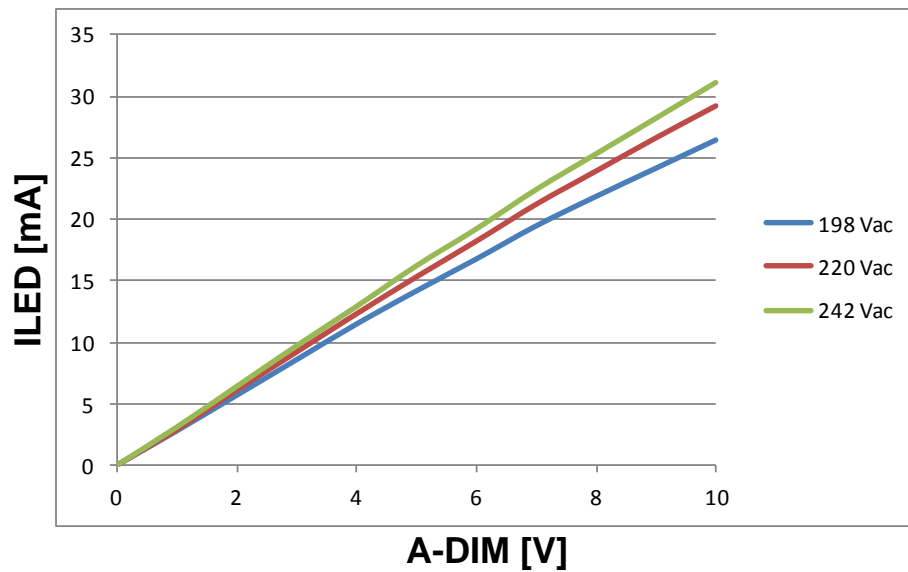

Figure 6. Ch1: V_{IN,ac}, 100 V/div, Ch4: I_{IN,ac} 20.0 mA/div



FL77905 analog dimming function can be implemented with a few external components.

The LED current at the rated line voltage can be adjusted within the range of 0% to 100% of the nominal current value from 0 to 10 V A-DIM signals at DIM pin



6.6. Electromagnetic Interference

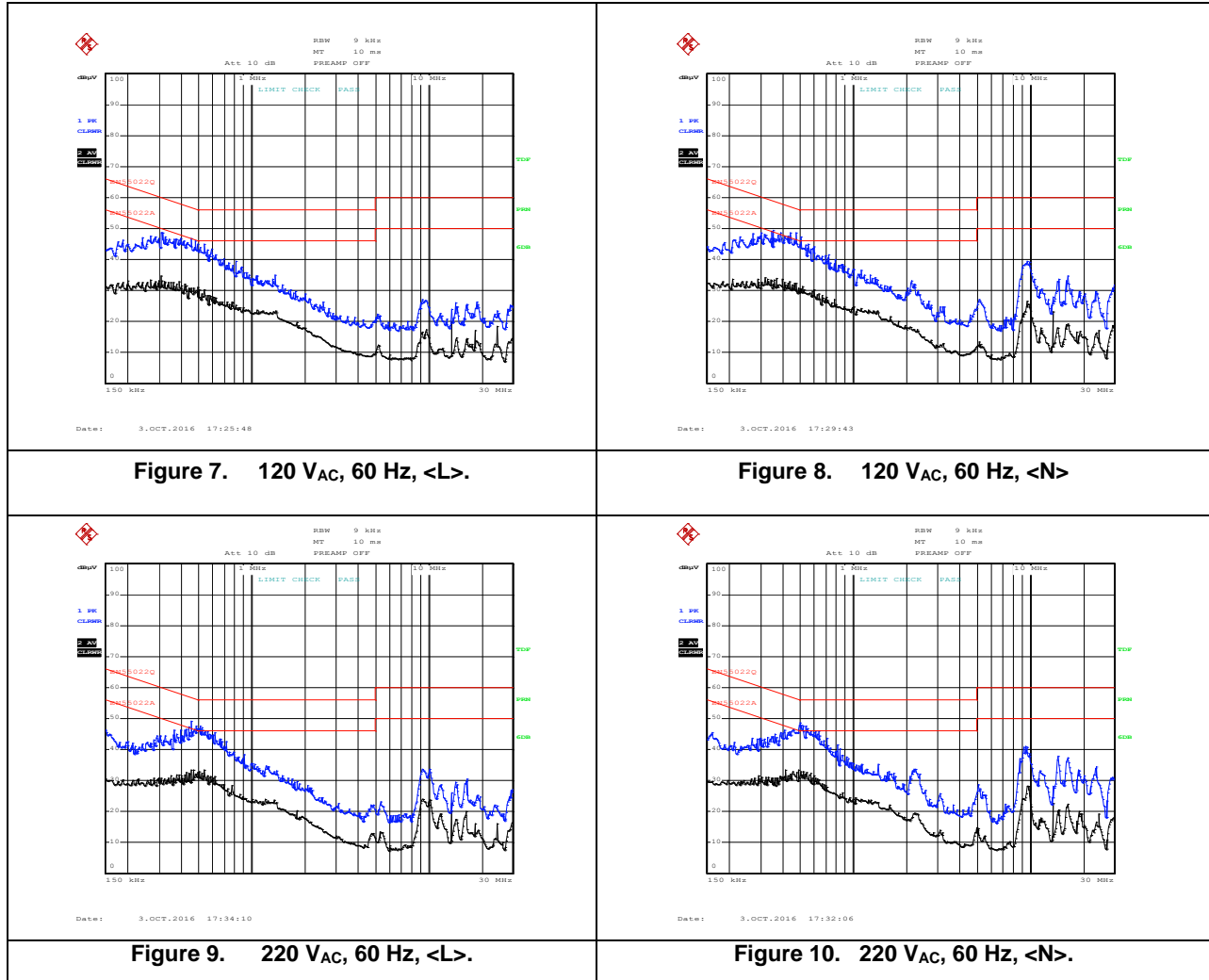

All measurements were conducted in observance of EN55022 criteria.

6.7. Surge Test

Input Voltage [V _{AC}]	Surge Type	Injection Location	Surge Level [kV]	Result
120	Line	L1 and L2	1.5	Pass
220	Line	L1 and L2	1.0	Pass



7. Revision History

Rev.	Date	Description
1.0	Nov. 2016	Initial Release

ON Semiconductor and the ON Semiconductor logo are trademarks of Semiconductor Components Industries, LLC dba ON Semiconductor or its subsidiaries in the United States and/or other countries. ON Semiconductor owns the rights to a number of patents, trademarks, copyrights, trade secrets, and other intellectual property. A listing of ON Semiconductor's product/patent coverage may be accessed at www.onsemi.com/site/pdf/Patent-Marking.pdf. ON Semiconductor reserves the right to make changes without further notice to any products herein. ON Semiconductor makes no warranty, representation or guarantee regarding the suitability of its products for any particular purpose, nor does ON Semiconductor assume any liability arising out of the application or use of any product or circuit, and specifically disclaims any and all liability, including without limitation special, consequential or incidental damages. Buyer is responsible for its products and applications using ON Semiconductor products, including compliance with all laws, regulations and safety requirements or standards, regardless of any support or applications information provided by ON Semiconductor. "Typical" parameters which may be provided in ON Semiconductor data sheets and/or specifications can and do vary in different applications and actual performance may vary over time. All operating parameters, including "Typicals" must be validated for each customer application by customer's technical experts. ON Semiconductor does not convey any license under its patent rights nor the rights of others. ON Semiconductor products are not designed, intended, or authorized for use as a critical component in life support systems or any FDA Class 3 medical devices or medical devices with a same or similar classification in a foreign jurisdiction or any devices intended for implantation in the human body. Should Buyer purchase or use ON Semiconductor products for any such unintended or unauthorized application, Buyer shall indemnify and hold ON Semiconductor and its officers, employees, subsidiaries, affiliates, and distributors harmless against all claims, costs, damages, and expenses, and reasonable attorney fees arising out of, directly or indirectly, any claim of personal injury or death associated with such unintended or unauthorized use, even if such claim alleges that ON Semiconductor was negligent regarding the design or manufacture of the part. ON Semiconductor is an Equal Opportunity/Affirmative Action Employer. This literature is subject to all applicable copyright laws and is not for resale in any manner.

PUBLICATION ORDERING INFORMATION

LITERATURE FULFILLMENT:

Literature Distribution Center for ON Semiconductor
19521 E. 32nd Pkwy, Aurora, Colorado 80011 USA
Phone: 303-675-2175 or 800-344-3860 Toll Free USA/Canada
Fax: 303-675-2176 or 800-344-3867 Toll Free USA/Canada
Email: orderlit@onsemi.com

N. American Technical Support: 800-282-9855 Toll Free
USA/Canada.

Europe, Middle East and Africa Technical Support:
Phone: 421 33 790 2910

Japan Customer Focus Center
Phone: 81-3-5817-1050

ON Semiconductor Website: www.onsemi.com

Order Literature: <http://www.onsemi.com/orderlit>

For additional information, please contact your local
Sales Representative

Компания «Океан Электроники» предлагает заключение долгосрочных отношений при поставках импортных электронных компонентов на взаимовыгодных условиях!

Наши преимущества:

- Поставка оригинальных импортных электронных компонентов напрямую с производств Америки, Европы и Азии, а так же с крупнейших складов мира;
- Широкая линейка поставок активных и пассивных импортных электронных компонентов (более 30 млн. наименований);
- Поставка сложных, дефицитных, либо снятых с производства позиций;
- Оперативные сроки поставки под заказ (от 5 рабочих дней);
- Экспресс доставка в любую точку России;
- Помощь Конструкторского Отдела и консультации квалифицированных инженеров;
- Техническая поддержка проекта, помощь в подборе аналогов, поставка прототипов;
- Поставка электронных компонентов под контролем ВП;
- Система менеджмента качества сертифицирована по Международному стандарту ISO 9001;
- При необходимости вся продукция военного и аэрокосмического назначения проходит испытания и сертификацию в лаборатории (по согласованию с заказчиком);
- Поставка специализированных компонентов военного и аэрокосмического уровня качества (Xilinx, Altera, Analog Devices, Intersil, Interpoint, Microsemi, Actel, Aeroflex, Peregrine, VPT, Syfer, Eurofarad, Texas Instruments, MS Kennedy, Miteq, Cobham, E2V, MA-COM, Hittite, Mini-Circuits, General Dynamics и др.);

Компания «Океан Электроники» является официальным дистрибьютором и эксклюзивным представителем в России одного из крупнейших производителей разъемов военного и аэрокосмического назначения «JONHON», а так же официальным дистрибьютором и эксклюзивным представителем в России производителя высокотехнологичных и надежных решений для передачи СВЧ сигналов «FORSTAR».



JONHON

«JONHON» (основан в 1970 г.)

Разъемы специального, военного и аэрокосмического назначения:

(Применяются в военной, авиационной, аэрокосмической, морской, железнодорожной, горно- и нефтедобывающей отраслях промышленности)

«FORSTAR» (основан в 1998 г.)

ВЧ соединители, коаксиальные кабели, кабельные сборки и микроволновые компоненты:

(Применяются в телекоммуникациях гражданского и специального назначения, в средствах связи, РЛС, а так же военной, авиационной и аэрокосмической отраслях промышленности).



Телефон: 8 (812) 309-75-97 (многоканальный)

Факс: 8 (812) 320-03-32

Электронная почта: ocean@oceanchips.ru

Web: <http://oceanchips.ru/>

Адрес: 198099, г. Санкт-Петербург, ул. Калинина, д. 2, корп. 4, лит. А