

ISL6539

Wide Input Range Dual PWM Controller with DDR Option

FN9144
Rev 6.00
Apr 29, 2010

The ISL6539 dual PWM controller delivers high efficiency and tight regulation from two voltage regulating synchronous buck DC/DC converters. It was designed especially for DDR DRAM, SDRAM, graphic chipset applications, and system regulators in high performance applications.

Voltage-feed-forward ramp modulation, current mode control, and internal feedback compensation provide fast response to input voltage and output load transients. Input current ripple is minimized by channel-to-channel PWM phase shift of 0°, 90° or 180° (determined by input voltage and status of the DDR pin).

The ISL6539 can control two independent output voltages adjustable from 0.9V to 5.5V or, by activating the DDR pin, transform into a complete DDR memory power supply solution. In DDR mode, CH2 output voltage VTT tracks CH1 output voltage VDDQ. CH2 output can both source and sink current, an essential power supply feature for DDR memory. The reference voltage VREF required by DDR memory is generated as well.

In dual power supply applications the ISL6539 monitors the output voltage of both CH1 and CH2. An independent PGOOD (power good) signal is asserted for each channel after the soft-start sequence has completed, and the output voltage is within PGOOD window. In DDR mode CH1 generates the only PGOOD signal.

Built-in overvoltage protection prevents the output from going above 115% of the set point by holding the lower MOSFET on and the upper MOSFET off. When the output voltage decays below the overvoltage threshold, normal operation automatically resumes. Once the soft-start sequence has completed, undervoltage protection latches the offending channel off if the output drops below 75% of its set point value for the dual switcher. Adjustable overcurrent protection (OCP) monitors the voltage drop across the $r_{DS(ON)}$ of the lower MOSFET. If more precise current-sensing is required, an external current sense resistor may be used.

Features

- Provides Regulated Output Voltage in the Range of 0.9V to 5.5V
- Complete DDR Memory Power Solution with VTT Tracks VDDQ/2 and VDDQ/2 Buffered Reference Output
- Supports both DDR-I and DDR2 Memory
- Lossless $r_{DS(ON)}$ Current-Sense Sensing
- Excellent Dynamic Response with Voltage Feed-Forward and Current Mode Control Accommodating Wide Range LC Filter Selections
- Dual Mode Operation - Operates Directly from a 5.0V to 15V Input or 3.3V/5V System Rail
- Undervoltage Lock-out on VCC Pin
- Power-good, Overcurrent, Overvoltage, Undervoltage protection for both Channels
- Synchronized 300kHz PWM Operation in PWM Mode
- Pb-Free (RoHS Compliant)

Applications

- Single and Dual Channel DDR Memory Power Systems
- Graphics Cards - GPU and Memory Supplies
- Supplies for Servers, Motherboards, FPGAs
- ASIC Power Supplies
- Embedded Processor and I/O Supplies
- DSP Supplies

Ordering Information

| PART NUMBER | PART MARKING | TEMP. RANGE (°C) | PACKAGE | PKG. DWG. # |
|-----------------------|--------------|------------------|-------------------------|-------------|
| ISL6539IAZ* (Note) | ISL 6539IAZ | -40 to +85 | 28 Ld QSOP (Pb-free) | M28.15 |
| ISL6539CAZ* (Note) | ISL 6539CAZ | -40 to +85 | 28 Ld QSOP (Pb-free) | M28.15 |

*Add "-T" suffix for tape and reel. Please refer to TB347 for details on reel specifications.

NOTE: These Intersil Pb-free plastic packaged products employ special Pb-free material sets, molding compounds/die attach materials, and 100% matte tin plate plus anneal (e3 termination finish, which is RoHS compliant and compatible with both SnPb and Pb-free soldering operations). Intersil Pb-free products are MSL classified at Pb-free peak reflow temperatures that meet or exceed the Pb-free requirements of IPC/JEDEC J STD-020.

Pinout

ISL6539
(28 LD QSOP)
TOP VIEW

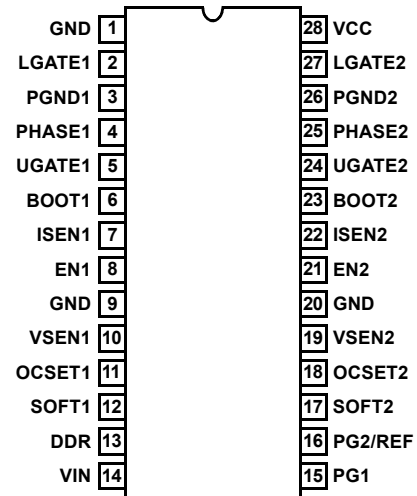

Generic Application Circuits

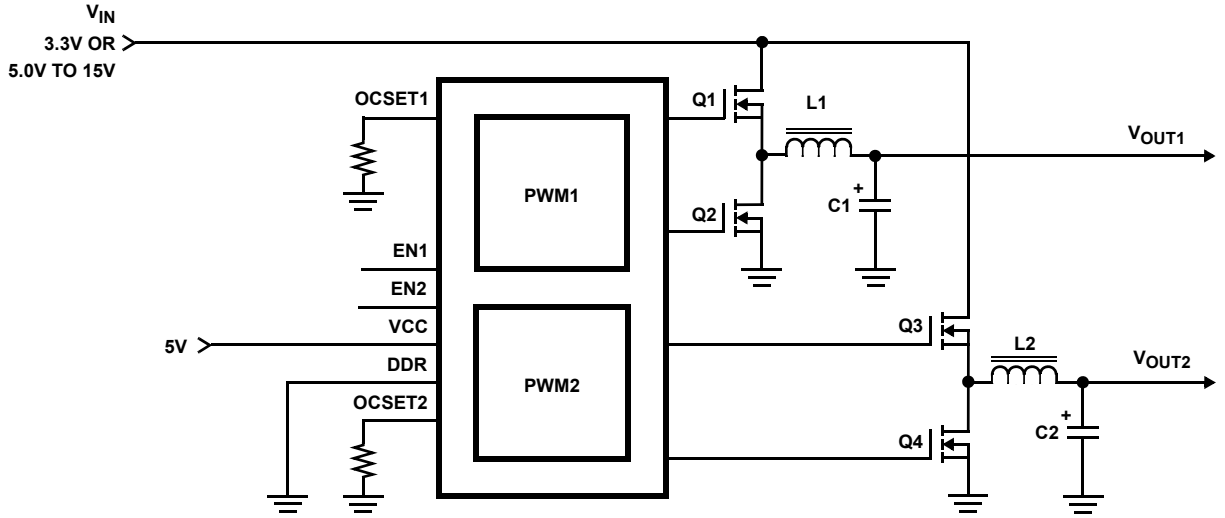

FIGURE 1. ISL6539 APPLICATION CIRCUIT FOR TWO CHANNEL POWER SUPPLY

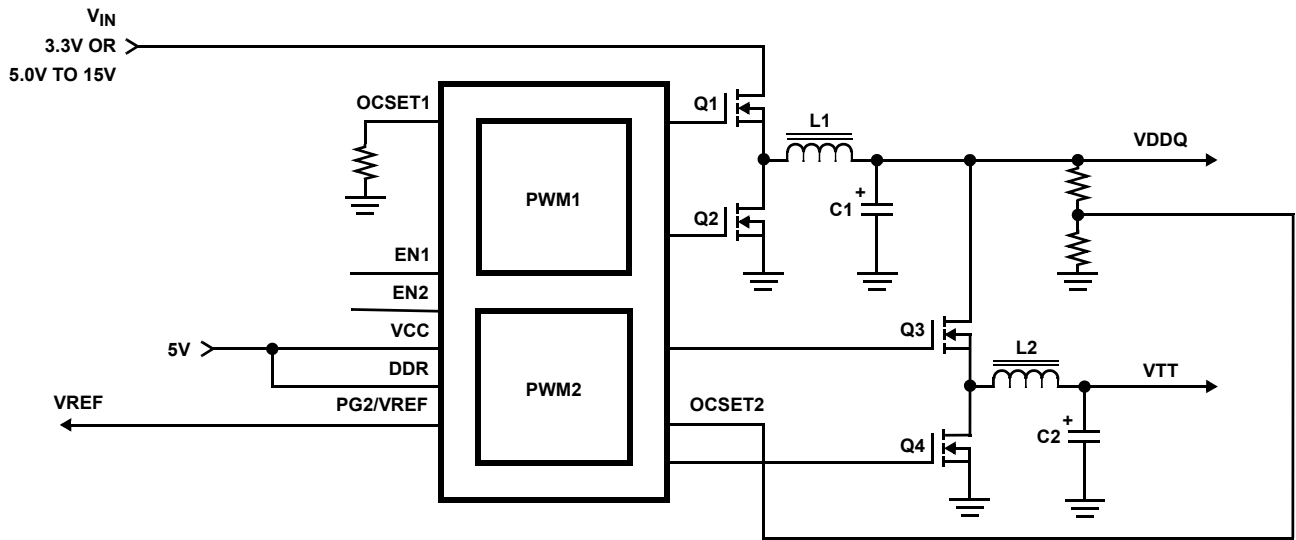

FIGURE 2. ISL6539 APPLICATION CIRCUIT FOR COMPLETE DDR MEMORY POWER SUPPLY

Absolute Maximum Ratings

| | |
|----------------------------|-------------------------------------|
| Bias Voltage, VCC | +6.5V |
| Input Voltage, VIN | +18.0V |
| PHASE, UGATE | GND - 5V (Note 1) to +24.0V |
| BOOT, ISEN | GND - 0.3V to +24.0V |
| BOOT with Respect to PHASE | +6.5V |
| All Other Pins | GND -0.3V to V _{CC} + 0.3V |

Thermal Information

| | |
|---|----------------------|
| Thermal Resistance (Typical, Note 2) | θ_{JA} (°C/W) |
| QSOP Package | 80 |
| Maximum Junction Temperature (Plastic Package) | +150°C |
| Maximum Storage Temperature Range | -65°C to +150°C |
| Pb-free reflow profile | see link below |
| http://www.intersil.com/pbfree/Pb-FreeReflow.asp | |

Recommended Operating Conditions

| | |
|--|-------------------------|
| Bias Voltage, VCC | +5.0V \pm 5% |
| Input Voltage, VIN | +3.3V or 5.0V to +18.0V |
| Ambient Temperature Range, Commercial | 0°C to +70°C |
| Junction Temperature Range, Commercial | 0°C to +125°C |
| Ambient Temperature Range, Industrial | -40°C to +85°C |
| Junction Temperature Range, Industrial | -40°C to +125°C |

CAUTION: Do not operate at or near the maximum ratings listed for extended periods of time. Exposure to such conditions may adversely impact product reliability and result in failures not covered by warranty.

NOTES:

- 250ns transient. See "Confining the Negative Phase Node Voltage Swing with Schottky Diode" on page 17.
- θ_{JA} is measured with the component mounted on a high effective thermal conductivity test board in free air. See Tech Brief TB379 for details.

Electrical Specifications Recommended Operating Conditions, Unless Otherwise Noted.

| PARAMETER | SYMBOL | TEST CONDITIONS | MIN | TYP | MAX | UNITS |
|------------------------------------|--------|--|------|-------|------|---------|
| VCC SUPPLY | | | | | | |
| Bias Current | ICC | LGATEx, UGATEx Open, VSENx forced above regulation point, DDR = 0, VIN >5V | - | 1.8 | 3.0 | mA |
| Shut-Down Current | ICCSN | | - | - | 1 | μ A |
| VCC UVLO | | | | | | |
| Rising VCC Threshold | VCCU | | 4.30 | 4.45 | 4.50 | V |
| Falling VCC Threshold | VCCD | | 4.00 | 4.14 | 4.34 | V |
| VIN | | | | | | |
| Input Voltage Pin Current (Sink) | IVIN | | - | - | 35 | μ A |
| Shut-Down Current | IVINS | | - | - | 1 | μ A |
| OSCILLATOR | | | | | | |
| Oscillator Frequency | fOSC | ISL6539C | 255 | 300 | 345 | kHz |
| | | ISL6539I | 245 | 300 | 345 | kHz |
| Ramp Amplitude, Peak-to-Peak | VR1 | VIN pin voltage = 16V (Note 3) | - | 2 | - | V |
| Ramp Amplitude, Peak-to-Peak | VR2 | VIN pin voltage = 5V (Note 3) | - | 0.625 | - | V |
| Ramp Offset | VROFF | (Note 3) | - | 1 | - | V |
| Ramp/VIN Gain | GRB1 | VIN pin voltage > 4.2V (Note 3) | - | 125 | - | mV/V |
| Ramp/VIN Gain | GRB2 | VIN pin voltage \leq 4.1V (Note 3) | - | 250 | - | mV/V |
| REFERENCE AND SOFT-START | | | | | | |
| Internal Reference Voltage | VREF | | - | 0.9 | - | V |
| Reference Voltage Accuracy | | | -1.0 | - | +1.0 | % |
| Soft-Start Current During Start-Up | ISOFT | | - | 4.5 | - | μ A |
| Soft-Start Complete Threshold | VST | (Note 3) | - | 1.5 | - | V |

Electrical Specifications Recommended Operating Conditions, Unless Otherwise Noted. (Continued)

| PARAMETER | SYMBOL | TEST CONDITIONS | MIN | TYP | MAX | UNITS |
|---|------------------|---|---------------|------|---------------|-------|
| PWM CONVERTERS | | | | | | |
| Load Regulation | | 0.0mA < IVOOUT1 < 5.0A; 5.0V < VIN < 15.0V | -2.0 | - | +2.0 | % |
| VSEN Pin Bias Current | IVSEN | (Note 3) | - | 80 | - | nA |
| Minimum Duty Cycle | DMIN | | - | 4 | - | % |
| Maximum Duty Cycle | DMAX | | - | 87 | - | % |
| Undervoltage Shut-Down Level | VUVL | Fraction of the set point; ~2μs noise filter | 70 | 75 | 80 | % |
| Overshoot Protection | VOVP1 | Fraction of the set point; ~2μs noise filter | 110 | 115 | - | % |
| GATE DRIVERS | | | | | | |
| Upper Drive Pull-Up Resistance | R2UGPUP | VCC = 5V | - | 4 | 8 | Ω |
| Upper Drive Pull-Down Resistance | R2UGPDN | VCC = 5V | - | 2.3 | 4 | Ω |
| Lower Drive Pull-Up Resistance | R2LGPUP | VCC = 5V | - | 4 | 8 | Ω |
| Lower Drive Pull-Down Resistance | R2LGPDN | VCC = 5V | - | 1.1 | 3 | Ω |
| POWER GOOD AND CONTROL FUNCTIONS | | | | | | |
| Power Good Lower Threshold | VPG ₋ | Fraction of the set point; ~3μs noise filter | 84 | 89 | 92 | % |
| Power Good Higher Threshold | VPG ₊ | Fraction of the set point; ~3μs noise filter. | 110 | 115 | 120 | % |
| PGOODx Leakage Current | IPGLKG | VPULLUP = 5.5V | - | - | 1 | μA |
| PGOODx Voltage Low | VPGOOD | IPGOOD = -4mA | - | 0.5 | 1 | V |
| ISEN Sourcing Current | | (Note 3) | - | - | 260 | μA |
| OCSET Sourcing Current Range | | | 2 | - | 20 | μA |
| EN - Low (Off) | | | - | - | 0.8 | V |
| EN - High (On) | | | 2.0 | - | - | V |
| DDR - Low (Off) | | | - | - | 0.8 | V |
| DDR - High (On) | | | 3 | - | - | V |
| DDR REF Output Voltage | VDDREF | DDR = 1, IREF = 0...10mA | 0.99* VOC2 | VOC2 | 1.01* VOC2 | V |
| DDR REF Output Current | IDDREF | DDR = 1 (Note 3) | - | 10 | 12 | mA |

NOTES:

3. Limits should be considered typical and are not production tested.

Functional Pin Description**GND (Pin 1, 9, 20)**

Signal ground for the IC. All three ground pins must be connected to ground for proper IC operation. Connect to the ground plane through a path as low in inductance as possible.

LGATE1, LGATE2 (Pin 2, 27)

Connect these pins to the gates of the corresponding lower MOSFETs. These pins provide the PWM-controlled gate drive for the lower MOSFETs.

PGND1, PGND2 (Pin 3, 26)

These pins provide the return connection for lower gate drivers, and are connected to sources of the lower MOSFETs of their respective converters. These pins must

be connected to the ground plane through a path as low in inductance as possible.

PHASE1, PHASE2 (Pin 4, 25)

The PHASE1 and PHASE2 points are the junction points of the upper MOSFET sources, output filter inductors, and lower MOSFET drains. Connect these pins to the respective converter's upper MOSFET source.

UGATE1, UGATE2 (Pin 5, 24)

Connect these pins to the gates of the corresponding upper MOSFETs. These pins provide the PWM-controlled gate drive for the upper MOSFETs.

BOOT1, BOOT2 (Pin 6, 23)

These pins power the upper MOSFET drivers of the PWM converter. Connect these pins to the junction of the bootstrap

capacitor with the cathode of the bootstrap diode. The anode of the bootstrap diode is connected to the VCC voltage.

ISEN1, ISEN2 (Pin 7, 22)

These pins are used to monitor the voltage drop across the lower MOSFET for current feedback and overcurrent protection. For precise current detection these inputs can be connected to the optional current sense resistors placed in series with the source of the lower MOSFETs.

EN1, EN2 (Pin 8, 21)

These pins enable operation of the respective converter when high. When both pins are low, the chip is disabled and only low leakage current is taken from VCC and VIN. EN1 and EN2 can be used independently to enable either Channel 1 or Channel 2, respectively.

VSEN1, VSEN2 (Pin 10, 19)

These pins are connected to the resistive dividers that set the desired output voltage. The PGOOD, UVP, and OVP circuits use this signal to report output voltage status.

OCSET1 (Pin 11)

This pin is a buffered 0.9V internal reference voltage. A resistor from this pin to ground sets the overcurrent threshold for the first controller.

SOFT1, SOFT2 (Pin 12, 17)

These pins provide soft-start function for their respective controllers. When the chip is enabled, the regulated 5 μ A pull-up current source charges the capacitor connected from the pin to ground. The output voltage of the converter follows the ramping voltage on the SOFT pin in the soft-start process with the SOFT pin voltage as reference. When the SOFT pin voltage is higher than 0.9V, the error amplifier will use the internal 0.9V reference to regulate output voltage.

In the event of undervoltage and overcurrent shutdown, the soft-start pin is pulled down through a 2k Ω resistor to ground to discharge the soft-start capacitor.

DDR (Pin 13)

When the DDR pin is low, the chip can be used as a dual switcher controller. The output voltage of the two channels can be programmed independently by VSENx pin resistor dividers. The PWM signals of Channel 1 and Channel 2 will be synchronized 180° out-of-phase.

When the DDR pin is high, the chip transforms into a complete DDR memory solution. The OCSET2 pin becomes an input through a resistor divider tracking to VDDQ/2. The PG2/REF pin becomes the output of the VDDQ/2 buffered voltage. The VDDQ/2 voltage is also used as the reference to the error amplifier by the second channel. The channel phase-shift synchronization is determined by the VIN pin when DDR = 1 as described in VIN (Pin 14).

VIN (Pin 14)

This pin has multiple functions. When connected to the input voltage, it provides a feed-forward input to the oscillator for the rejection of input voltage variation. The ramp of the PWM

comparator is proportional to the voltage on this pin (see Table 1 and Table 2 for details). While the DDR pin is high (in the DDR application) and when the VIN pin voltage is tied to 5V, it commands 90° out-of-phase channel synchronization, with the second channel lagging the first channel, to reduce inter-channel interference. While the DDR pin is high (in the DDR application) and when the VIN pin voltage is tied to ground, it commands in-phase channel synchronization.

PG1 (Pin 15)

PGOOD1 is an open drain output used to indicate the status of the output voltage. This pin is pulled low when the first channel output is out of $\pm 11\%$ of the set value.

PG2/REF (Pin 16)

This pin has a double function, depending on the mode of operation.

When the chip is used as a dual channel PWM controller (DDR = 0), the pin provides an open drain PGOOD2 function for the second channel the same way as PG1. The pin is pulled low when the second channel output is out of $\pm 11\%$ of the set value.

In DDR mode (DDR = 1), this pin is the output of the buffer amplifier that takes VDDQ/2 voltage applied to OCSET2 pin from the resistor divider. It can source a typical 10mA current.

OCSET2 (Pin 18)

In a dual channel application with DDR = 0, a resistor from this pin to ground sets the overcurrent threshold for the second channel controller. Its voltage is the buffered internal 0.9V reference.

In the DDR application with DDR = 1, this pin connects to the center point of a resistor divider tracking the VDDQ/2. This voltage is then buffered by an amplifier voltage follower and sent to the PG2/REF pin. It sets the reference voltage of Channel 2 for its regulation.

VCC (Pin 28)

VCC provides the bias supply for the ISL6539. The supply to VCC should be locally bypassed using a ceramic capacitor.

Typical Application

Figures 3 and 4 show the application circuits of a dual channel DC/DC converter.

The power supply in Figure 3 provides +V2.5 and +V1.8 voltages for memory and the graphics interface chipset from a 5.0VDC to 15VDC input rail.

Figure 4 illustrates the application circuit for a DDR memory power solution. The power supply shown in Figure 4 generates +2.5V VDDQ voltage. The +1.25V VTT termination voltage tracks VDDQ/2 and is derived from +2.5V VDDQ. To complete the DDR memory power requirements, the +1.25V reference voltage is provided through the PG2 pin. In this application circuit shown, two output 220 μ F capacitors are used at the outputs.

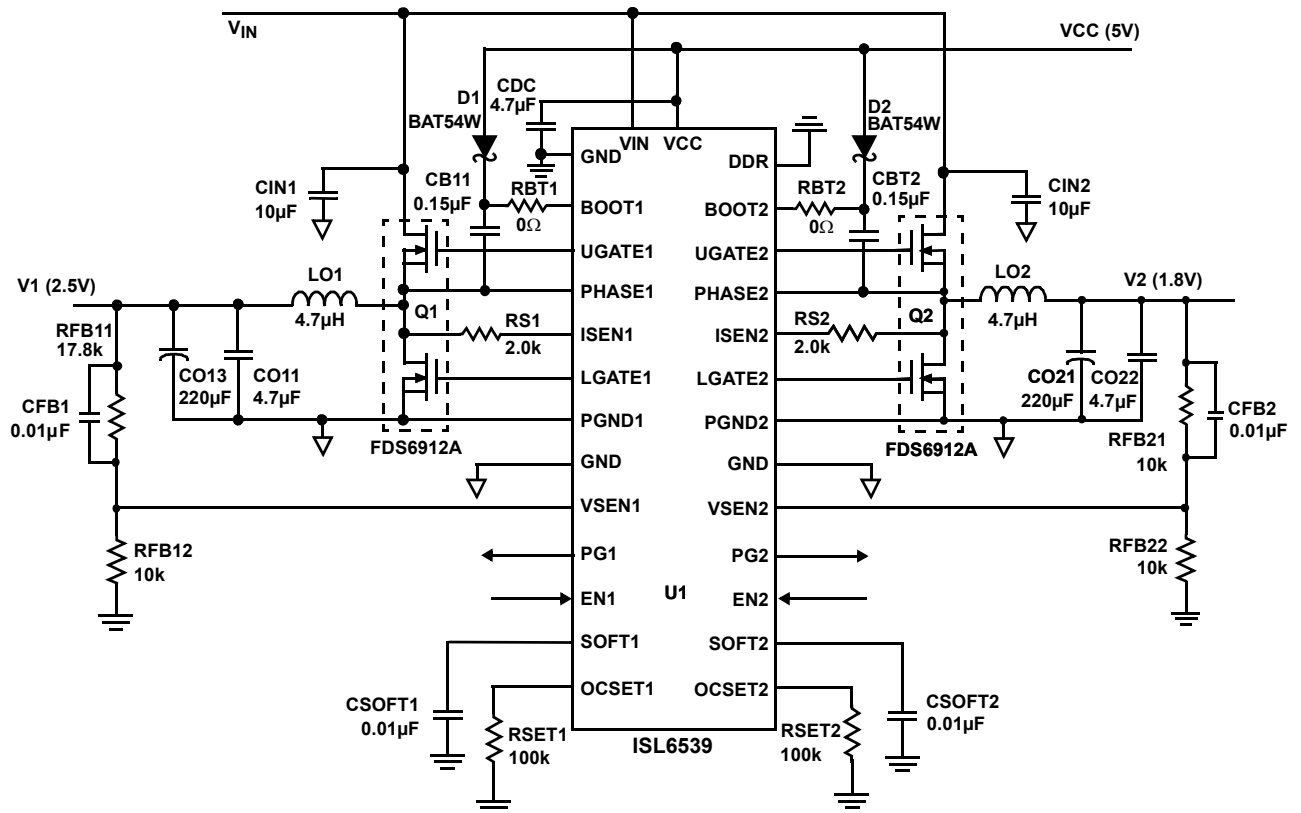

FIGURE 3. TYPICAL APPLICATION CIRCUIT AS DUAL SWITCHER, VOUT1 = 2.5V, VOUT2 = 1.8V

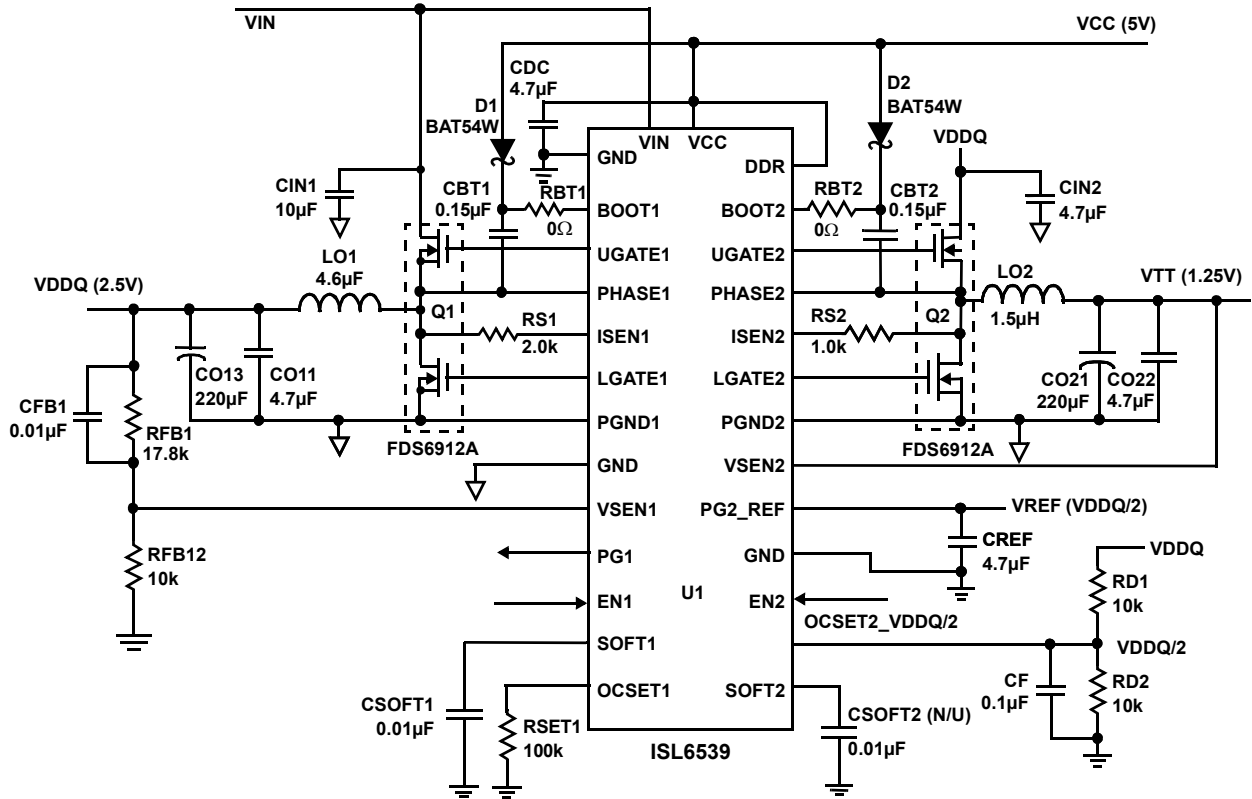
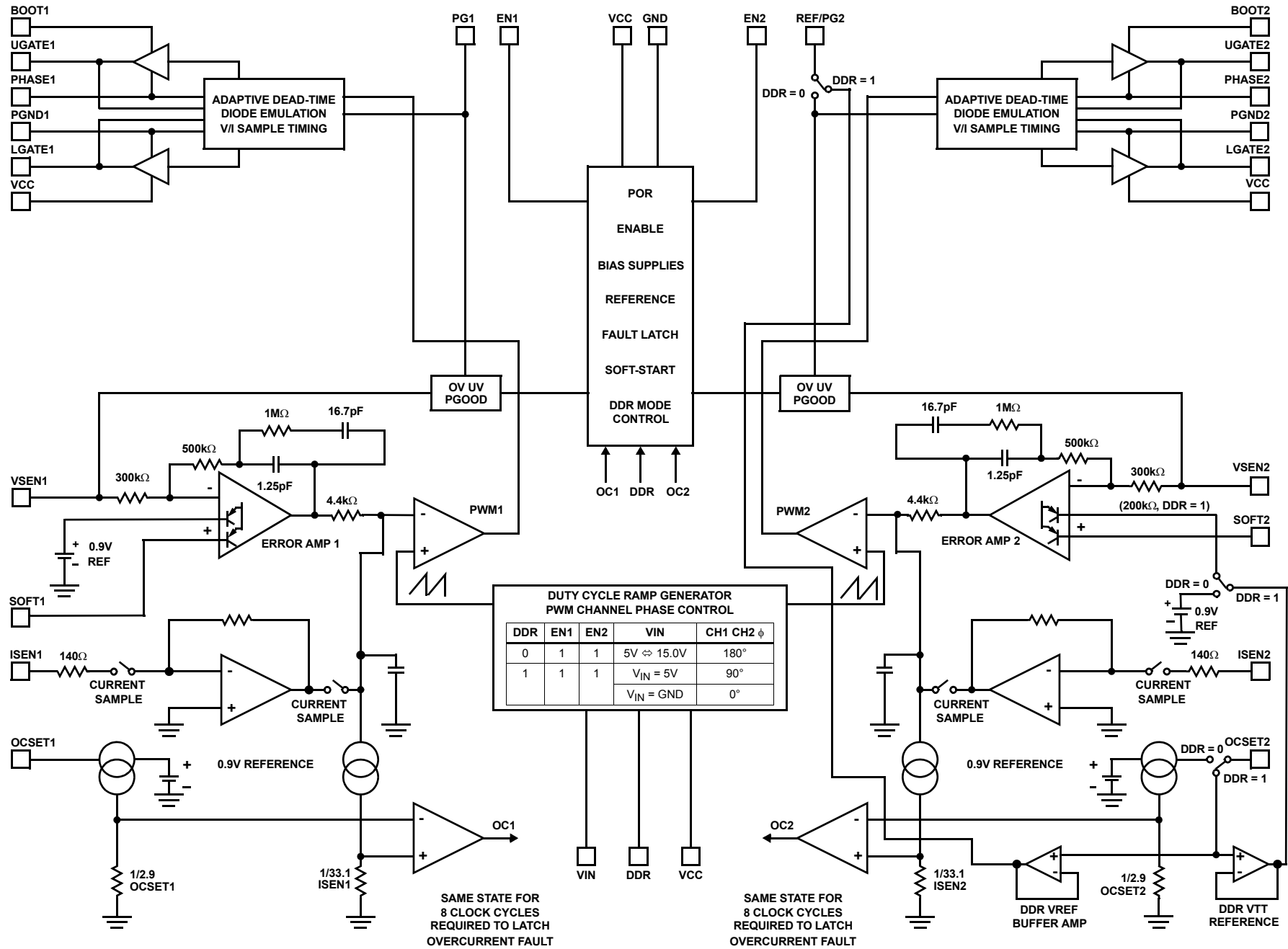

FIGURE 4. TYPICAL APPLICATION AS DDR MEMORY POWER SUPPLY, VOUT1 = 2.5V, VOUT2 = 1.25V

Block Diagram



Theory of Operation

Operation

The ISL6539 is a dual channel PWM controller intended for use in power supplies for graphic chipsets, SDRAM, DDR DRAM, or other power applications. The IC integrates two control circuits for two synchronous buck converters. The output voltage of each controller can be set in the range of 0.9V to 5.5V by an external resistive divider.

The synchronous buck converters can operate from either an unregulated DC source with a voltage ranging from 5.0V to 15V, or from a regulated system rail of 3.3V or 5V. In either operational mode the controller is biased from the +5V source.

The controllers operate in the current mode with input voltage feed-forward which simplifies feedback loop compensation and rejects input voltage variation. An integrated feedback loop compensation dramatically reduces the number of external components.

The ISL6539 has a special means to rearrange its internal architecture into a complete DDR solution. When the DDR pin is set high, the second channel can provide the capability to track the output voltage of the first channel. The buffered reference voltage required by DDR memory chips is also provided.

Initialization

The ISL6539 initializes if at least one of the enable pins is set high. The Power-On Reset (POR) function continually monitors the bias supply voltage on the VCC pin, and initiates soft-start operation when EN1 or EN2 is high after the input supply voltage exceeds 4.45V. Should this voltage drop lower than 4.14V, the POR disables the chip.

Soft-Start

When soft-start is initiated, the voltage on the SOFT pin of the enabled channel starts to ramp up gradually with the internal 5 μ A current charging the soft-start capacitor. The output voltage follows the soft-start voltage.

When the SOFT pin voltage reaches 0.9V, the output voltage comes into regulation. When the SOFT voltage reaches 1.5V, the power good (PGOOD) is enabled. The soft-start process is depicted in Figure 5.

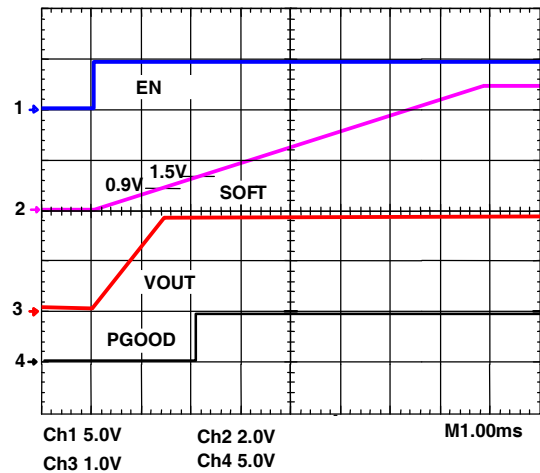

FIGURE 5. START-UP

Even though the soft-start pin voltage continues to rise after reaching 1.5V, this voltage does not affect the output voltage.

The soft-start time (the time from the moment when EN becomes high to the moment when PGOOD is reported) is determined by Equation 1:

$$T_{\text{SOFT}} = \frac{1.5\text{V} \times C_{\text{soft}}}{5\mu\text{A}} \quad (\text{EQ. 1})$$

The time it takes the output voltage to come into regulation can be obtained from Equation 2:

$$T_{\text{RISE}} = 0.6 \times T_{\text{SOFT}} \quad (\text{EQ. 2})$$

During soft-start, before the PGOOD pin is enabled, the undervoltage protection is prohibited. The overvoltage and overcurrent protection functions are enabled.

If the output capacitor has residue voltage before start-up, both lower and upper MOSFETs are in off-state until the soft-start capacitor charges equal the VSEN pin voltage. This will ensure the output voltage starts from its existing voltage level.

Output Voltage Program

The output voltage of either channel is set by a resistive divider from the output to ground. The center point of the divider is connected to the VSEN pin as shown in Figure 6. The output voltage value is determined by Equation 3.

$$V_O = \frac{0.9\text{V} \cdot (R1 + R2)}{R2} \quad (\text{EQ. 3})$$

where 0.9V is the value of the internal reference. The VSEN pin voltage is also used by the controller for the power good function and to detect undervoltage and overvoltage conditions.

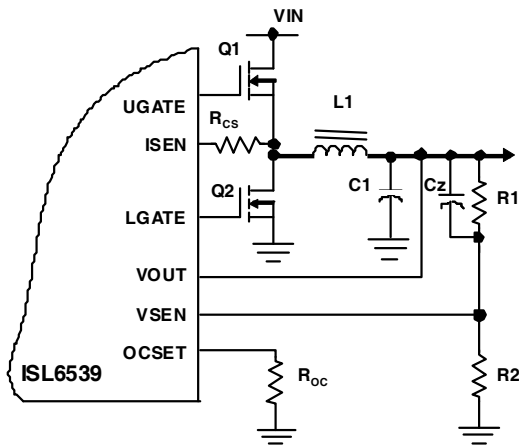

FIGURE 6. THE INTERNAL COMPENSATOR

Current Sensing

The current on the lower MOSFET is sensed by measuring its voltage drop within its on-time. In order to activate the current sampling circuitry, two conditions need to be met. (1) the LGATE is high and (2) the phase pin sees a negative voltage for regular buck operation, which means the current is freewheeling through lower MOSFET. For the second channel of the DDR application, the phase pin voltage needs to be higher than 0.1V to activate the current sensing circuit for bidirectional current sensing. The current sampling finishes at about 400ns after the lower MOSFET has turned on. This current information is held for current mode control and overcurrent protection. The current sensing pin can source up to 260 μ A. The current sense resistor and OCSET resistor can be adjusted simultaneously for the same overcurrent protection level; however, the current sensing gain will be changed only according to the current sense resistor value, which will affect the current feedback loop gain. The middle point of the ISEN current can be at 75 μ A, but it can be tuned up and down to fit application needs.

If another channel is switching at the moment the current sample is finishing, it could cause current sensing error and phase voltage jitter. In the design stage, the duty cycles and synchronization have to be analyzed for all the input voltage and load conditions to reduce the chance of current sensing error. The relationship between the sampled current and MOSFET current is given by Equation 4:

$$I_{SEN}(R_{CS} + 140) = r_{DS(ON)} I_D \quad (\text{EQ. 4})$$

Which means the current sensing pin will source current to make the voltage drop on the MOSFET equal to the voltage generated on the sensing resistor, plus the internal resistor, along the ISEN pin current flowing path.

Feedback Loop Compensation

Both channel PWM controllers have internally compensated error amplifiers. To make internal compensation possible, several design measures were taken.

- The ramp signal applied to the PWM comparator has been made proportional to the input voltage by the VIN pin. This keeps the product of the modulator gain and the input voltage constant even when the input voltage varies.
- The load current proportional signal is derived from the voltage drop across the lower MOSFET during the PWM off time interval, and is subtracted from the error amplifier output signal before the PWM comparator input. This effectively creates an internal current control loop.

The resistor connected to the ISEN pin sets the gain in the current sensing. The following expression estimates the required value of the current sense resistor, depending on the maximum continuous load current, and the value of the MOSFETs $r_{DS(ON)}$, assuming the ISEN pin sources 75 μ A current.

$$R_{CS} = \frac{I_{MAX} \cdot r_{DS(ON)}}{75\mu A} - 140\Omega \quad (\text{EQ. 5})$$

Because the current sensing circuit is a sample-and-hold type, the information obtained at the last moment of the sampling is being used. This current sensing circuit samples the inductor current very close to its peak value. The current feedback essentially injects a resistor R_i in series with the original LC filter as shown in Figure 7, where the sample-and-hold effect of the current loop has been ignored. V_c and V_o are small signal components extracted from its DC operation points.

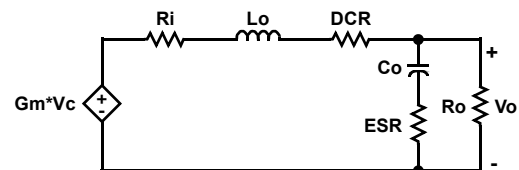

FIGURE 7. THE EQUIVALENT CIRCUIT OF THE POWER STAGE WITH CURRENT LOOP INCLUDED

The value of the injected resistor can be estimated by Equation 6:

$$R_i = \frac{V_{IN}}{V_{ramp}} \frac{r_{DS(ON)}}{R_{CS} + 140} \cdot 4.4k\Omega \quad (\text{EQ. 6})$$

R_i is in $k\Omega$, and r_{DS} and R_{CS} are in Ω . V_{IN} divided by V_{ramp} is defined as G_m , which is a constant 8dB or 18dB for both channels in dual switcher applications, when V_{IN} is above 3V. Refer to Tables 1 and 2 for the ramp amplitude in different V_{IN} pin connections. The feed-forward effect of the V_{IN} is reflected in G_m . V_c is defined as the error amplifier output voltage.

TABLE 1. PWM COMPARATOR RAMP AMPLITUDE FOR DUAL SWITCHER APPLICATION

| | VIN PIN CONNECTIONS | | VRAMP AMPLITUDE |
|-------------|---------------------|----------------------|-----------------|
| Ch1 and Ch2 | Input Voltage | Input voltage > 4.2V | $V_{IN}/8$ |
| | | Input voltage < 4.2V | 1.25V |
| | GND | | 1.25V |

TABLE 2. PWM COMPARATOR RAMP VOLTAGE AMPLITUDE FOR DDR APPLICATION

| | VIN PIN CONNECTION | | VRAMP AMPLITUDE |
|-----|----------------------|----------------------|-----------------|
| Ch1 | Input Voltage | Input voltage > 4.2V | $V_{IN}/8$ |
| | | Input voltage < 4.2V | 1.25V |
| | GND | | 1.25V |
| Ch2 | Input voltage > 4.2V | | 0.625V |
| | GND | | 1.25V |

The small signal transfer function from the error amplifier output voltage V_c to the output voltage V_o can be written in Equation 7:

$$G(s) = G_m \frac{R_o}{R_i + DCR + R_o} \frac{\left(\frac{s}{W_z} + 1\right)}{\left(\frac{s}{W_{p1}} + 1\right)\left(\frac{s}{W_{p2}} + 1\right)} \quad (\text{EQ. 7})$$

The DC gain is derived by shorting the inductor and opening the capacitor. There is one zero and two poles in this transfer function.

The zero is related to ESR and the output capacitor.

The first pole is a low frequency pole associated with the output capacitor and its charging resistors. The inductor can be regarded as short. The second pole is the high frequency pole related to the inductor. At high frequency the output cap can be regarded as a short circuit. By approximation, the poles and zero are inversely proportional to the time constants, associated with inductor and capacitor, by Equations 8, 9 and 10:

$$W_z = \frac{1}{ESR * C_o} \quad (\text{EQ. 8})$$

$$W_{p1} = \frac{1}{(ESR + (R_i + DCR) \parallel R_o) * C_o} \quad (\text{EQ. 9})$$

$$W_{p2} = \frac{R_i + DCR + ESR \parallel R_o}{L_o} \quad (\text{EQ. 10})$$

Since the current loop separates the LC resonant poles into two distant poles, and ESR zero tends to cancel the high frequency pole, the second order system behaves like a first order system. This control method simplifies the design of the internal compensator and makes it possible to

accommodate many applications having a wide range of parameters. The schematic for the internal compensator is shown in Figure 8.

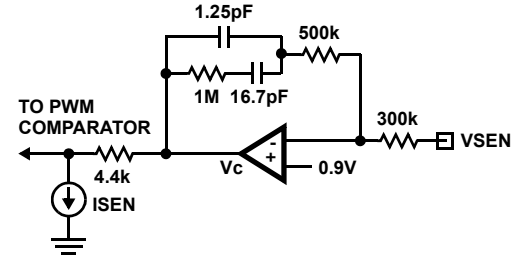
**FIGURE 8. THE INTERNAL COMPENSATOR**

Its transfer function can be written as Equation 11:

$$G_{comp}(s) = \frac{1.857 \cdot 10^5 \left(\frac{s}{2\pi f_{z1}} + 1\right) \left(\frac{s}{2\pi f_{z2}} + 1\right)}{s \left(\frac{s}{2\pi f_{p1}} + 1\right)} \quad (\text{EQ. 11})$$

where:

$$f_{z1} = 6.98\text{kHz}, f_{z2} = 380\text{kHz}, \text{ and } f_{p1} = 137\text{kHz}$$

Outside the ISL6539 chip, a capacitor C_z can be placed in parallel with the top resistor in the feedback resistor divider, as shown in Figure 6. In this case the transfer function from the output voltage to the middle point of the divider can be written as:

$$G_{fd}(s) = \frac{R_2}{R_1 + R_2} \frac{sR_1C_z + 1}{s(R_1 \parallel R_2)C_z + 1} \quad (\text{EQ. 12})$$

The ratio of R_1 and R_2 is determined by the output voltage set point; therefore, the position of the pole and zero frequency in Equation 12 may not be far apart; however, they can improve the loop gain and phase margin with the proper design.

The C_z can bring the high frequency transient output voltage variation directly to the VSEN pin to cause the PGOOD drop. Such an effect should be considered in the selection of C_z .

From the analysis in Equation 12, the system loop gain can be written as Equation 13:

$$G_{loop}(s) = G(s) \cdot G_{comp}(s) \cdot G_{fd}(s) \quad (\text{EQ. 13})$$

Figure 9 shows the composition of the system loop gain. As shown in the graph, the power stage became a well damped second order system compared to the LC filter characteristics. The ESR zero is so close to the high frequency pole that they cancel each other out. The power stage behaves like a first order system. With an internal compensator, the loop gain transfer function has a cross over frequency at about 30kHz. With a given set of parameters, including the MOSFET $r_{DS(ON)}$, current sense

resistor R_{CS} , output LC filter, and feedback network, the system loop gain can be accurately analyzed and modified by the system designers based on the applications requirements.

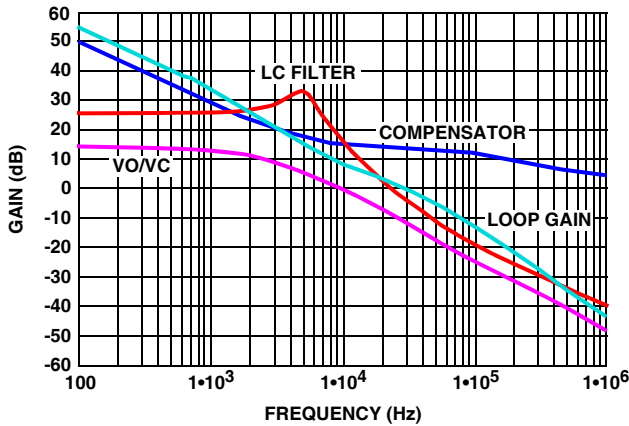

FIGURE 9. THE BODE PLOT OF THE LC FILTER, COMPENSATOR, CONTROL TO OUTPUT VOLTAGE TRANSFER FUNCTION, AND SYSTEM LOOP GAIN

Gate Control Logic

The gate control logic translates generated PWM signals into gate drive signals providing necessary amplification, level shift, and shoot-through protection. It bears some functions that help to optimize the IC performance over a wide range of the operational conditions. As MOSFET switching time can vary dramatically from type to type, and with the input voltage, the gate control logic provides adaptive dead time by monitoring real gate waveforms of both the upper and the lower MOSFETs.

Dual-Step Conversion

The ISL6539 dual channel controller can be used either in power systems with a single-stage power conversion or in systems where some intermediate voltages are initially established. The choice of the approach may be dictated by the overall system design criteria, or the approach may be a matter of voltages available to the system designer.

When the output voltage is regulated from low voltage such as 5V, the feed-forward ramp may become too shallow, creating the possibility of duty-factor jitter; this is particularly relevant in a noisy environment. Noise susceptibility, when operating from low level regulated power sources, can be improved by connecting the VIN pin to ground, by which the feed-forward ramp generator will be internally reconnected from the VIN pin to the VCC pin, and the ramp slew rate will be doubled.

Voltage Monitor and Protections

The converter output is monitored and protected against extreme overload, short circuit, overvoltage, and undervoltage conditions. A sustained overload on the output sets the PGOOD low and latches off the offending channel of the chip. The controller operation can be restored by cycling the VCC voltage or toggling both enable (EN) pins to low to clear the latch.

Power Good

In the soft-start process, the PGOOD is established after the soft pin voltage is at 1.5V. In normal operation, the PGOOD window is 100mV below the 0.9V and 135mV higher than 0.9V. The VSEN pin has to stay within this window for PGOOD to be high. Since the VSEN pin is used for both feedback and monitoring purposes, the output voltage deviation can be coupled directly to the VSEN pin by the capacitor in parallel with the voltage divider as shown in Figure 6. In order to prevent false PGOOD drop, capacitors need to parallel at the output to confine the voltage deviation with severe load step transient. The PGOOD comparator has a built-in 3 μ s filter. PGOOD is an open drain output.

Overcurrent Protection

In dual switcher application, both PWM controllers use the lower MOSFETs on-resistance $r_{DS(ON)}$, to monitor the current for protection against shorted outputs. The sensed current from the ISEN pin is compared with a current set by a resistor connected from the OCSET pin to ground:

$$R_{SET} = \frac{10.3V}{\frac{I_{OC} \cdot r_{DS(ON)}}{R_{CS} + 140\Omega} + 8\mu A} \quad (\text{EQ. 14})$$

where I_{OC} is a desired overcurrent protection threshold and R_{CS} is the value of the current sense resistor connected to the ISEN pin. The 8 μ A is the offset current added on top of the sensed current from the ISEN pin for internal circuit biasing.

If the lower MOSFET current exceeds the overcurrent threshold, a pulse skipping circuit is activated. The upper MOSFET will not be turned on as long as the sensed current is higher than the threshold value, limiting the current supplied by the DC voltage source. The current in the lower MOSFET will be continuously monitored until it is lower than the OC threshold value, then the following UGATE pulse will be released and normal current sample resumes. This kind of operation remains for 8 clock cycles after the overcurrent comparator was tripped for the first time. If after the first 8 clock cycles the current exceeds the overcurrent threshold again, in a time interval of another 8 clock cycles, the overcurrent protection latches and disables the offending channel. If the overcurrent condition goes away during the first 8 clock cycles, normal operation is restored and the overcurrent circuit resets itself at the end of 16 clock cycles (See Figure 10).

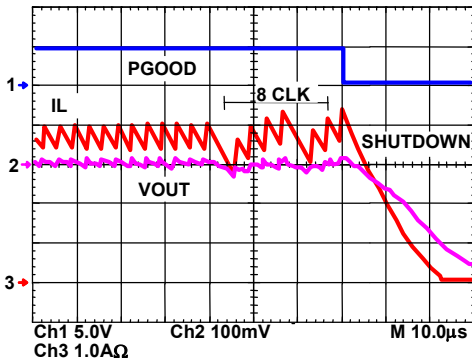

FIGURE 10. OVERCURRENT PROTECTION

Due to the nature of the current sensing technique and to accommodate a wide range of the $r_{DS(ON)}$ variation, the value of the overcurrent threshold should be set at about 180% of the nominal load value. If more accurate current protection is desired, a current sense resistor placed in series with the lower MOSFET source may be used. The inductor current going through the lower MOSFET is sensed and held at 400ns after the upper MOSFET is turned off; therefore, the sensed current is very close to its peak value. The inductor peak current can be written as Equation 15:

$$I_{peak} = \frac{(V_{IN} - V_{out}) \cdot V_{out}}{2L \cdot f_{SW} \cdot V_{IN}} + I_{load} \quad (\text{EQ. 15})$$

As seen from Equation 15, the inductor peak current changes with the input voltage and the inductor value once an output voltage is selected.

After overcurrent protection is activated, there are two ways to bring the offending channel back: (1) Both EN1 and EN2 have to be held low to clear the latch, (2) To recycle the V_{CC} of the chip, the POR will clear the latch.

Undervoltage Protection

In the process of operation, if a short circuit occurs, the output voltage will drop quickly. Before the overcurrent protection circuit responds, the output voltage will fall out of the required regulation range. The chip comes with undervoltage protection. If a load step is strong enough to pull the output voltage lower than the undervoltage threshold, the offending channel latches off immediately. The undervoltage threshold is 75% of the nominal output voltage. Toggling both enables to low, or recycling V_{CC} , will clear the latch and bring the chip back to operation.

Overvoltage Protection

Should the output voltage increase over 115% of the normal value due to the upper MOSFET failure, or for other reasons, the overvoltage protection comparator will force the synchronous rectifier gate driver high. This action actively pulls down the output voltage. As soon as the output voltage drops below the threshold, the OVP comparator is disengaged. The MOSFET driver will restore its normal operation. When the OVP occurs, the PGOOD will drop to low as well.

This OVP scheme provides a 'soft' crowbar function, which helps clamp the voltage overshoot, and does not invert the output voltage when otherwise activated with a continuously high output from lower MOSFET driver (a common problem for OVP schemes with a latch).

DDR Application

High throughput Double Data Rate (DDR) memory chips are expected to take the place of traditional memory chips. A novel feature associated with this type of memory are the referencing and data bus termination techniques. These techniques employ a reference voltage, V_{REF} , that tracks the center point of V_{DDQ} and V_{SS} voltages, and an additional V_{TT} power source where all terminating resistors are connected. Despite the additional power source, the overall memory power consumption is reduced compared to traditional termination.

The added power source has a cluster of requirements that should be observed and considered. Due to the reduced differential thresholds of DDR memory, the termination power supply voltage, V_{TT} , closely tracks $V_{DDQ}/2$ voltage. Another very important feature of the termination power supply is the capability to operate at equal efficiency in sourcing and sinking modes. The V_{TT} supply regulates the output voltage with the same degree of precision when current is flowing from the supply to the load, and when the current is diverted back from the load into the power supply.

The ISL6539 dual channel PWM controller possesses several important enhancements that allow re-configuration for DDR memory applications, and provides all three voltages required in a DDR memory compliant computer.

To reconfigure the ISL6539 for a complete DDR solution, the DDR pin should be set high permanently to the V_{CC} rail. This activates some functions inside the chip that are specific to DDR memory power needs.

In the DDR application presented in Figure 4, the first controller regulates the V_{DDQ} rail to 2.5V. The output voltage is set by external dividers R_{fb1} and R_{fb12} . The second controller regulates the V_{TT} rail to $V_{DDQ}/2$. The OCSET2 pin function is now different, and serves as an input that brings $V_{DDQ}/2$ voltage, created by the R_{d1} and R_{d2} divider, inside the chip, effectively providing a tracking function for the V_{TT} voltage.

The PG2 pin function is also different in DDR mode. This pin becomes the output of the buffer, whose input is connected to the center point of the R/R divider from the V_{DDQ} output by the OCSET2 pin. The buffer output voltage serves as a 1.25V reference for the DDR memory chips. Current capability of this pin is 10mA (12mA max).

For the V_{TT} channel where output is derived from the V_{DDQ} output, some control and protective functions have been significantly simplified. For example, the overcurrent, and overvoltage, and undervoltage protections for the second

channel controller are disabled when the DDR pin is set high. As the VTT channel tracks the VDDQ/2 voltage, the soft-start function is not required, and the SOFT2 pin may be left open, in the event both channels are enabled simultaneously. However, if the VTT channel is enabled later than the VDDQ, the SOFT2 pin must have a capacitor in place to ensure soft-start. In case of overcurrent or undervoltage caused by short circuit on VTT, the fault current will propagate to the first channel and shut down the converter.

The VREF voltage will be present even if the VTT is disabled.

Channel Synchronization in DDR Applications

The presence of two PWM controllers on the same die requires channel synchronization, to reduce inter-channel interference that may cause the duty factor jitter and increased output ripple.

The PWM controller is at greatest noise susceptibility when an error signal on the input of the PWM comparator approaches the decision-making point. False triggering may occur, causing jitter and affecting the output regulation.

A common approach used to synchronize dual channel converters is out-of-phase operation. Out-of-phase operation reduces input current ripple and provides a minimum interference for channels that control different voltage levels.

When used in a DDR application with cascaded converters (VTT generated from VDDQ), several methods of synchronization are implemented in the ISL6539. When the DDR pin is connected to GND for dual switcher applications, the channels operate 180° out-of-phase. In the DDR mode, when the DDR pin is connected to VCC, the channels operate either with 0° phase shift, when the VIN pin is connected to the GND, or with 90° phase shift if the VIN pin is connected to a voltage higher than 4.2V.

The following table lists the different synchronization schemes and their usage:

| DDR PIN | VIN PIN | SYNCHRONIZATION |
|---------|-----------------------------------|-------------------|
| 0 | V _{IN} pin >4.2V | 180° out-of-phase |
| 1 | V _{IN} pin voltage <4.2V | 0° phase |
| 1 | V _{IN} pin voltage >4.1V | 90° phase shift |

Application Information

Design Procedures

GENERAL

A ceramic decoupling capacitor should be used between the VCC and GND pin of the chip. There are three major currents drawn from the decoupling capacitor:

1. the quiescent current, supporting the internal logic and normal operation of the IC
2. the gate driver current for the lower MOSFETs
3. and the current going through the external diodes to the bootstrap capacitor for upper MOSFET.

In order to reduce the noisy effect of the bootstrap capacitor current to the IC, a small resistor, such as 10Ω, can be used with the decoupling cap to construct a low pass filter for the IC, as shown in Figure 11.

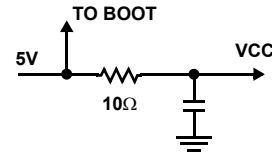

FIGURE 11. INPUT FILTERING FOR THE CHIP

The soft-start capacitor and the resistor divider setting the output voltage is easy to select as discussed in the “Block Diagram” on page 8.

Selection of the Current Sense Resistor

The value of the current sense resistor determines the gain of the current sensing circuit. It affects the current loop gain and the overcurrent protection setpoint. The voltage drop on the lower MOSFET is sensed within 400ns after the upper MOSFET is turned off. The current sense pin has a 140Ω resistor in series with the external current sensing resistor. The current sense pin can source up to a 260μA current while sensing current on the lower MOSFET, in such a way that the voltage drop on the current sensing path would equal to the voltage on the MOSFET.

$$I_{\text{SOURCING}}(140\Omega + R_{\text{CS}}) = I_{\text{D}}r_{\text{DS(ON)}} \tag{EQ. 16}$$

I_D can be assumed to be the inductor peak current. In a worst case scenario, the high temperature r_{DS(ON)} could increase to 150% of the room temperature level. During overload condition, the MOSFET drain current I_D could be 130% higher than the normal inductor peak. If the inductor has 30% peak-to-peak ripple, I_D would equal to 115% of the load current. The design should consider the above factors so that the maximum I_{SOURCING} will not saturate to 260μA under worst case conditions. To be safe, I_{SOURCING} should be less than 100μA in normal operation at room temperature. The formula in the earlier discussion assumes a 75μA sourcing current. Users can tune the sourcing current of the ISEN pin to meet the overcurrent protection and the change the current loop gain. The lower the current sensing resistor, the higher gain of the current loop, which can damp the output LC filter more.

A higher current-sensing resistor will decrease the current sense gain. If the phase node of the converter is very noisy due to poor layout, the sensed current will be contaminated, resulting in duty cycle jittering by the current loop. In such a case, a bigger current sense resistor can be used to reduce both real and noise current levels. This can help damp the phase node waveform jittering.

Sometimes, if the phase node is very noisy, a resistor can be put on the ISEN pin to ground. This resistor together with the R_{CS} can divide the phase node voltage down, seen by the internal current sense amplifier, and reduce noise coupling.

Sizing the Overcurrent Setpoint Resistor

The internal 0.9V reference is buffered to the OCSET pin with a voltage follower (refer to the equivalent circuit in Figure 12). The current going through the external overcurrent set resistor is sensed from the OCSET pin. This current, divided by 2.9, sets up the overcurrent threshold and compares with the scaled ISEN pin current going through R_{CS} with an $8\mu\text{A}$ offset. Once the sensed current is higher than the threshold value, an OC signal is generated. The first OC signal starts a counter and activates a pulse skipping function. The inductor current will be continuously monitored through the phase node voltage after the first OC trip. As long as the sensed current exceeds the OC threshold value, the following PWM pulse will be skipped. This operation will be the same for 8 switching cycles. Another OC occurring between 8 to 16 switching cycles would result in a latch off with both upper and lower drives low. If there is no OC within 8 to 16 switching cycles, normal operation resumes.

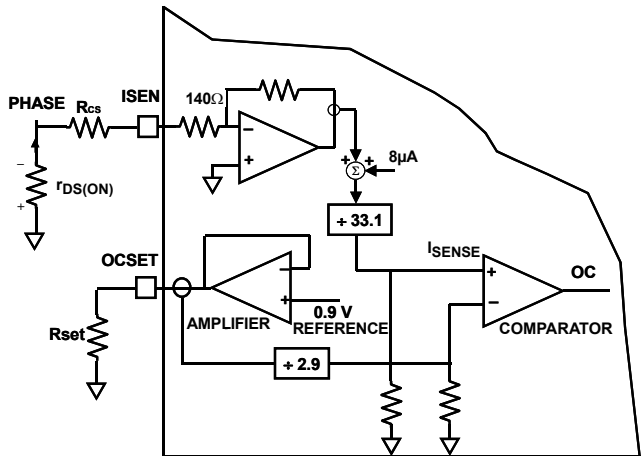

FIGURE 12. EQUIVALENT CIRCUIT FOR OC SIGNAL GENERATOR

Based on the previous description and the “Block Diagram” on page 8, the OC set resistor can be calculated as Equation 17:

$$R_{\text{set}} = \frac{10.3\text{V}}{\frac{I_{\text{OC}} r_{\text{DS(ON)}}}{R_{\text{CS}} + 140} + 8\mu\text{A}} \quad (\text{EQ. 17})$$

I_{OC} is the inductor peak current and not the load current. Since inductor peak current changes with input voltage, it is better to use an oscilloscope when testing the overcurrent setting point to monitor the inductor current, and to determine when the OC occurs. To get consistent test results on different boards, it is best to keep the MOSFET at a fixed temperature.

The MOSFET will not heat-up when applying a very low frequency and short load pulses with an electronic load to the output.

As an example, assume the following:

- The maximum normal operation load current is 1
- The OC set point is 10% higher than the maximum load current
- The inductor peak current is 1.15 to 1.3 times higher than the load current, depending on the inductor value and the input voltage
- The $r_{\text{DS(ON)}}$ has a 45% increase at higher temperature

I_{OC} should be set at least 1.8 to 2 times higher than the maximum load current to avoid nuisance overcurrent trip.

Selection of the LC Filter

The duty cycle of a buck converter is a function of the input voltage and output voltage. Once an output voltage is fixed, it can be written as Equation 18:

$$D(V_{\text{IN}}) = \frac{V_{\text{OUT}}}{V_{\text{IN}}} \quad (\text{EQ. 18})$$

The switching frequency, f_{sw} , of ISL6539 is 300kHz. The peak-to-peak ripple current going through the inductor can be written as Equation 19:

$$I_{\text{P-P}} = \frac{V_{\text{OUT}}(1 - D(V_{\text{IN}}))}{f_{\text{sw}} * L} \quad (\text{EQ. 19})$$

As higher ripple current will result in higher switching loss and higher output voltage ripple, the peak-to-peak current of the inductor is generally designed with a 20% to 40% peak-to-peak ripple of the nominal operation current. Based on this assumption, the inductor value can be selected with Equation 19. In addition to the mechanical dimension, a shielded ferrite core inductor with a very low DC resistance, DCR, is preferred for less core loss and copper loss. The DC copper loss of the inductor can be estimated by Equation 20:

$$P_{\text{copper}} = I_{\text{load}}^2 \text{DCR} \quad (\text{EQ. 20})$$

The inductor copper loss can be significant in the total system power loss. Attention has to be given to the DCR selection. Another factor to consider when choosing the inductor is its saturation characteristics at elevated temperature. Saturated inductors could result in nuisance OC, or OV trip.

Output voltage ripple and the transient voltage deviation are factors that have to be taken into consideration when selecting an output capacitor. In addition to high frequency noise related MOSFET turn-on and turn-off, the output voltage ripple includes the capacitance voltage drop and ESR voltage

drop caused by the AC peak-to-peak current. These two voltages can be represented by Equations 21 and 22:

$$\Delta V_c = \frac{I_{pp}}{8Cf_{sw}} \quad (\text{EQ. 21})$$

$$\Delta V_{esr} = I_{p-p}ESR \quad (\text{EQ. 22})$$

These two components constitute a large portion of the total output voltage ripple. Several capacitors have to be paralleled in order to reduce the ESR and the voltage ripple. If the output of the converter has to support another load with high pulsating current, such as the first channel in Figure 4, it feeds into the VTT channel which draws high pulsating current. More capacitors are needed in order to reduce the equivalent ESR and suppress the voltage ripple to a tolerable level.

To support a load transient that is faster than the switching frequency, more capacitors have to be used to reduce the voltage excursion during load step change. Another aspect of the capacitor selection is that the total AC current going through the capacitors has to be less than the rated RMS current specified on the capacitors, to prevent the capacitor from overheating.

For DDR applications, as the second channel draws pulsate current directly from the first channel, it is recommended to parallel capacitors for output of the first channel to reduce ESR and smooth ripple. Excessive high ripple voltage at the output can propagate into the output of the error amplifier and cause too much phase voltage jitter.

Input Capacitor Selection

The important parameters for the bulk input capacitance are the voltage rating and the RMS current rating. For reliable operation, select bulk capacitors with voltage and current ratings above the maximum input voltage and largest RMS current required by the circuit. Their voltage rating should be at least 1.25 times greater than the maximum input voltage, while a voltage rating of 1.5 times is a conservative guideline. For most cases, the RMS current rating requirement for the input capacitor of a buck regulator is approximately 1/2 the DC load current.

The maximum RMS current required by the regulator may be closely approximated through Equation 23:

$$I_{Cin(RMS)} = \sqrt{I_{OUT}^2 \cdot (D - D^2) + I_{Ripple(p-p)}^2 \cdot \frac{D}{12}} \quad (\text{EQ. 23})$$

In addition to the bulk capacitance, some low ESL ceramic decoupling is recommended to be used between the drain terminal of the upper MOSFET and the source terminal of the lower MOSFET, in order to clamp the parasitic voltage ringing at the phase node in switching.

Choosing MOSFETs

For a maximum input voltage of 15V, at least a minimum 30V MOSFETs should be used. The design has to trade off the gate charge with the $r_{DS(ON)}$ of the MOSFET:

- For the lower MOSFET, before it is turned on, the body diode has been conducting. The lower MOSFET driver will not charge the miller capacitor of this MOSFET.
- In the turning off process of the lower MOSFET, the load current will shift to the body diode first. The high dv/dt of the phase node voltage will charge the miller capacitor through the lower MOSFET driver sinking current path.

This results in much less switching loss of the lower MOSFETs.

The duty cycle is often very small in high battery voltage applications, and the lower MOSFET will conduct most of the switching cycle; therefore, the lower the $r_{DS(ON)}$ of the lower MOSFET, the less the power loss. The gate charge for this MOSFET is usually of secondary consideration.

The upper MOSFET does not have this zero voltage switching condition, and because the upper MOSFET conducts for less time compared to the lower MOSFET, the switching loss tends to be dominant. Priority should be given to the MOSFETs with less gate charge, so that both the gate driver loss, and switching loss, will be minimized.

For the lower MOSFET, its power loss can be assumed to be the conduction loss only.

$$P_{lower}(V_{IN}) \approx (1 - D(V_{IN}))I_{load}^2 r_{DS(ON)Lower} \quad (\text{EQ. 24})$$

For the upper MOSFET, its conduction loss can be written as:

$$P_{uppercond}(V_{IN}) = D(V_{IN})I_{load}^2 r_{DS(ON)upper} \quad (\text{EQ. 25})$$

and its switching loss can be written as:

$$P_{uppersw}(V_{IN}) = \frac{V_{IN}I_{valley}t_{on}f_{sw}}{2} + \frac{V_{IN}I_{peak}t_{off}f_{sw}}{2} \quad (\text{EQ. 26})$$

The peak and valley current of the inductor can be obtained based on the inductor peak-to-peak current and the load current. The turn-on and turn-off time can be estimated with the given gate driver parameters in the "Electrical Specifications" Table on page 4. For example, if the gate driver turn-on path MOSFET has a typical ON-resistance of 4Ω, its maximum turn-on current is 1.2A with 5V V_{CC} . This current would decay as the gate voltage increased. With the assumption of linear current decay, the turn-on time of the MOSFETs can be written as Equation 27:

$$t_{on} = \frac{2Q_{gd}}{I_{driver}} \quad (\text{EQ. 27})$$

Q_{gd} is used because when the MOSFET drain-to-source voltage has fallen to zero, it gets charged. Similarly, the turn-off time can be estimated based on the gate charge and the gate drivers sinking current capability.

The total power loss of the upper MOSFET is the sum of the switching loss and the conduction loss. The temperature rise on the MOSFET can be calculated based on the thermal impedance given on the datasheet of the MOSFET. If the temperature rise is too much, a different MOSFET package size, layout copper size, and other options have to be considered to keep the MOSFET cool. The temperature rise can be calculated by Equation 28:

$$T_{\text{rise}} = \theta_{\text{ja}} P_{\text{total power loss}} \quad (\text{EQ. 28})$$

The MOSFET gate driver loss can be calculated with the total gate charge and the driver voltage V_{cc} . The lower MOSFET only charges the miller capacitor at turn-off.

$$P_{\text{driver}} = V_{\text{cc}} Q_{\text{gs}} f_{\text{sw}} \quad (\text{EQ. 29})$$

Based on Equation 29, the system efficiency can be estimated by the designer.

Confining the Negative Phase Node Voltage Swing with Schottky Diode

At each switching cycle, the body diode of the lower MOSFET will conduct before the MOSFET is turned-on, as the inductor current is flowing to the output capacitor. This will result in a negative voltage on the phase node. The higher the load current, the lower this negative voltage. This voltage will ring back less negative when the lower MOSFET is turned on.

A total 400ns period is given to the current sample-and-hold circuit on the ISEN pin to sense the current going through the lower MOSFET after the upper MOSFET turns off. An excessive negative voltage on the lower MOSFET will be treated as overcurrent. In order to confine this voltage, a Schottky diode can be used in parallel with the lower MOSFET for high load current applications. PCB layout parasitics should be reduced in order to reduce the negative ringing of phase voltage.

Another concern for the phase node voltage going into negative is that the boot strap capacitor between the BOOT and PHASE pin could get be charged higher than VCC voltage, exceeding the 6.5V absolute maximum voltage between BOOT and PHASE when the phase became negative. A resistor can be placed between the cathode of the boot strap diode and BOOT pin to increase the charging time constant of the boot cap. This resistor will not affect the turn-on and off of the upper MOSFET.

A Schottky diode can reduce the reverse recovery of the lower MOSFET when transitioning from freewheeling to blocking, therefore, it is generally good practice to have a Schottky diode closely parallel with the lower MOSFET. B340LA, from Diodes, Inc.®, can be used as the external Schottky diode.

Tuning the Turn-on of Upper MOSFET

The turn-on speed of the upper MOSFET can be adjusted by the resistor connecting the boot cap to the boot pin of the chip. This resistor can confine the voltage ringing on the boot

capacitor from coupling to the boot pin. This resistor slows down only the turn-on of the upper MOSFET. If the upper MOSFET is turned on very fast, it could result in a very high dv/dt on the phase node, which could couple into the lower MOSFET gate through the miller capacitor, causing momentous shoot-through. This phenomenon, together with the reverse recovery of the body diode of the lower MOSFET, can overshoot the phase node voltage to beyond the voltage rating of the MOSFET. However, a bigger resistor will slow the turn-on of the MOSFET too much and lower the efficiency. Trade-offs need to be made in choosing such a resistor.

System Loop Gain and Stability

The system loop gain is a product of three transfer functions:

1. the transfer function from the output voltage to the feedback point,
2. the transfer function of the internal compensation circuit from the feedback point to the error amplifier output voltage,
3. and the transfer function from the error amplifier output to the converter output voltage.

These transfer functions are written in a closed form in “Theory of Operation” on page 9. The external capacitor, in parallel with the upper resistor of the resistor divider, C_z , can be used to tune the loop gain and phase margin. Other component parameters, such as the inductor value, can be changed for a wider cross-over frequency of the system loop gain. A body plot of the loop gain transfer function with a 45° phase margin (a 60° phase margin is better) is desirable to cover component parameter variations.

Testing the Overvoltage on Buck Converters

For synchronous buck converters, if an active source is used to raise the output voltage for the overvoltage protection test, the buck converter will behave like a boost converter and dump energy from the external source to the input. The overvoltage test can be done on ISL6539 by connecting the VSEN pin to an external voltage source or signal generator through a diode. When the external voltage (or signal generator voltage) is tuned to a higher level than the overvoltage threshold (the lower MOSFET will be on), it indicates the overvoltage protection works. This kind of overvoltage protection does not require an external Schottky in parallel with the output capacitor.

Layout Considerations

Power and Signal Layer Placement on the PCB

As a general rule, power layers should be close together, either on the top or bottom of the board, with signal layers on the opposite side of the board. For example, prospective layer arrangement on a 4-layer board is shown in the following:

1. Top Layer: ISL6539 signal lines
2. Signal Ground

3. Power Layers: Power Ground
4. Bottom Layer: Power MOSFET, Inductors and other Power traces

It is a good engineering practice to separate the power voltage and current flowing path from the control and logic level signal path. The controller IC will stay on the signal layer, which is isolated by the signal ground to the power signal traces.

Component Placement

The control pins of the two-channel ISL6539 are located symmetrically on two sides of the IC; it is desirable to arrange the two channels symmetrically around the IC.

The power MOSFET should be close to the IC so that the gate drive signal, the LAGTE_x, UGATE_x, PHASE_x, BOOT_x, and ISEN_x traces can be short.

Place the components in such a way that the area under the ISL6539 has fewer noise traces with high dv/dt and di/dt, such as gate signals and phase node signals.

Signal Ground and Power Ground Connection

At minimum, a reasonably large area of copper, which will shield other noise couplings through the IC, could be used as signal ground beneath the ISL6539. The best tie-point between the signal ground and the power ground is at the negative side of the output capacitor on each channel, where there is less noise. Noisy traces beneath the ISL6539 are not recommended.

GND and VCC Pins

At least one high quality ceramic decoupling cap should be used across these two pins. A via can tie GND to signal ground. Since Pin 1 (GND) and Pin 28 (VCC) are close together, the decoupling cap can be put close to the IC.

Pin 2 and Pin 27, the LGATE1 and LGATE2

These are the gate drive signals for the bottom MOSFETs of the buck converter. The signal going through these traces have both high dv/dt and high di/dt, with high peak charging and discharging current. These two traces should be short, wide, and away from other traces. There should be no other weak signal traces in parallel with these traces on any layer.

Pin 3 and Pin 26, PGND1 and PGND2

Each pin should be laid out to the negative side of the relevant output cap with separate traces. The negative side of the output capacitor must be close to the source node of the bottom MOSFET. These traces are the return path of LGATE1 and LGATE2.

Pin 4 and Pin 25, the PHASE Pin

These traces should be short, and positioned away from other weak signal traces. The phase node has a very high dv/dt with a voltage swing from the input voltage to ground. No trace should be in parallel with these traces. These traces are also the return path for UGATE1 and UGATE2.

Connect these pins to the respective converters' upper MOSFET source.

Pin 5 and Pin 24, the UGATE1 and UGATE2

These pins have a square shape waveform with high dv/dt. It provides the gate drive current to charge and discharge the top MOSFET with high di/dt. This trace should be wide, short, and away from other traces similar to the LGATE_x.

Pin 6 and Pin 23, the BOOT1 and BOOT2

These pins di/dt are as high as that of the UGATE_x; therefore, the traces should be as short as possible.

Pin 7 and Pin 22, the ISEN1 and ISEN2

The ISEN trace should be a separate trace, and independently go to the drain terminal of the lower MOSFET. The current sense resistor should be close to ISEN pin.

The loop formed by the bottom MOSFET, output inductor, and output capacitor, should be very small. The source of the bottom MOSFET should tie to the negative side of the output capacitor in order for the current sense pin to get the voltage drop on the $r_{DS(ON)}$.

Pin 8 and Pin 21, the EN1 and EN2

These pins stay high in enable mode and low in idle mode and are relatively robust. Enable signals should refer to the signal ground.

Pin 10 and Pin 19, VSEN1 and VSEN2

There is usually a resistor divider connecting the output voltage to this pin. The input impedance of these two pins is high because they are the input to the amplifiers. The correct layout should bring the output voltage from the regulation point to the SEN pin with kelvin traces. Build the resistor divider close to the pin so that the high impedance trace is shorter.

Pin 11 and Pin 18, the OCSET1 and OCSET2

In dual switcher mode operation, the overcurrent set resistor should be put close to this pin. In DDR mode operation, the voltage divider, which divides the VDQQ voltage in half, should be put very close to this pin. The other side of the OC set resistor should connect to signal ground.

Pin 12 and Pin 17, SOFT1 and SOFT2

The soft-start capacitors should be laid out close to this pin. The other side of the soft-start cap should tie to signal ground.

Pin 15 and Pin 16, PG1 and PG2 for Dual Switcher Operation

For dual switcher operations, these two lines are less noise sensitive. For DDR applications, a capacitor should be placed to the PG2/REF pin.

Pin 13, DDR

This pin should connect to VCC in DDR applications, and to signal ground in dual switcher applications.

Pin 14, VIN

This pin connects to battery voltage, and is less noise sensitive.

Copper Size for the Phase Node

Big coppers on both sides of the Phase node introduce parasitic capacitance. The capacitance of PHASE should be kept very low to minimize ringing. If ringing is excessive, it could easily affect current sample information. It would be best to limit the size of the PHASE node copper in strict accordance with the current and thermal management of the application.

Identify the Power and Signal Ground

The input and output capacitors of the converters, the source terminals of the bottom switching MOSFET PGND1, and PGND2, should be closely connected to the power ground. The other components should connect to signal ground. Signal and power ground are tied together at the negative terminal of the output capacitors.

Decoupling Capacitor for Switching MOSFET

It is recommended that ceramic caps be used closely connected to the drain side of the upper MOSFET, and the source of the lower MOSFET. This capacitor reduces the noise and the power loss of the MOSFET. Refer to Figure 13 for the power component placement.

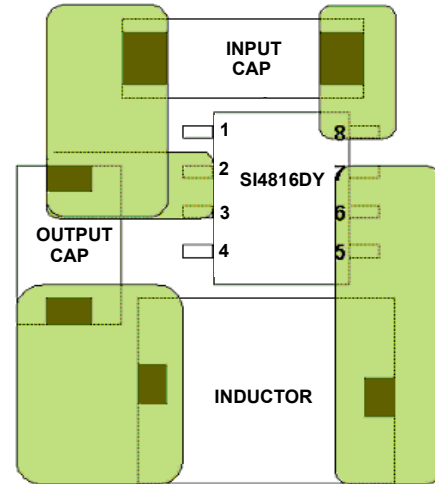

FIGURE 13. A GOOD EXAMPLE OF POWER COMPONENT REPLACEMENT. THIS SHOWS THAT THE NEGATIVE OF THE INPUT AND OUTPUT CAP AND THE SOURCE OF THE MOSFET ARE TIED AT ONE POINT.

© Copyright Intersil Americas LLC 2004-2010. All Rights Reserved.
All trademarks and registered trademarks are the property of their respective owners.

For additional products, see www.intersil.com/en/products.html

Intersil products are manufactured, assembled and tested utilizing ISO9001 quality systems as noted in the quality certifications found at www.intersil.com/en/support/qualandreliability.html

Intersil products are sold by description only. Intersil may modify the circuit design and/or specifications of products at any time without notice, provided that such modification does not, in Intersil's sole judgment, affect the form, fit or function of the product. Accordingly, the reader is cautioned to verify that datasheets are current before placing orders. Information furnished by Intersil is believed to be accurate and reliable. However, no responsibility is assumed by Intersil or its subsidiaries for its use; nor for any infringements of patents or other rights of third parties which may result from its use. No license is granted by implication or otherwise under any patent or patent rights of Intersil or its subsidiaries.

For information regarding Intersil Corporation and its products, see www.intersil.com

**Shrink Small Outline Plastic Packages (SSOP)
Quarter Size Outline Plastic Packages (QSOP)**

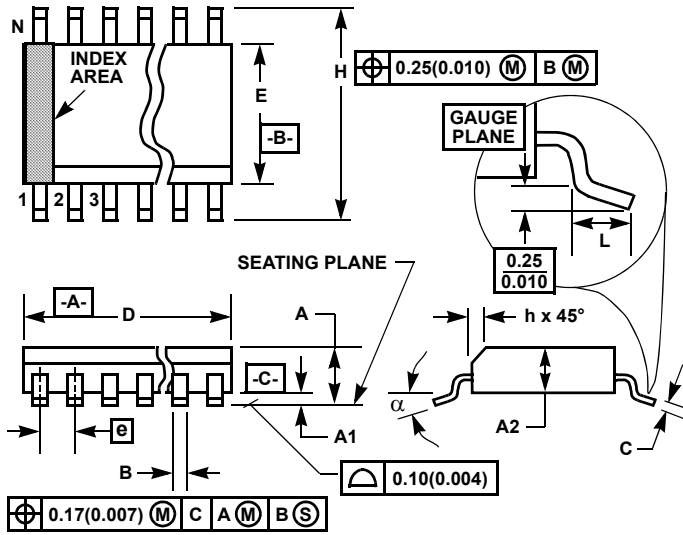

NOTES:

1. Symbols are defined in the "MO Series Symbol List" in Section 2.2 of Publication Number 95.
2. Dimensioning and tolerancing per ANSI Y14.5M-1982.
3. Dimension "D" does not include mold flash, protrusions or gate burrs. Mold flash, protrusion and gate burrs shall not exceed 0.15mm (0.006 inch) per side.
4. Dimension "E" does not include interlead flash or protrusions. Interlead flash and protrusions shall not exceed 0.25mm (0.010 inch) per side.
5. The chamfer on the body is optional. If it is not present, a visual index feature must be located within the crosshatched area.
6. "L" is the length of terminal for soldering to a substrate.
7. "N" is the number of terminal positions.
8. Terminal numbers are shown for reference only.
9. Dimension "B" does not include dambar protrusion. Allowable dambar protrusion shall be 0.10mm (0.004 inch) total in excess of "B" dimension at maximum material condition.
10. Controlling dimension: INCHES. Converted millimeter dimensions are not necessarily exact.

M28.15

**28 LEAD SHRINK SMALL OUTLINE PLASTIC PACKAGE
(0.150" WIDE BODY)**

| SYMBOL | INCHES | | MILLIMETERS | | NOTES |
|--------|-----------|--------|-------------|-------|-------|
| | MIN | MAX | MIN | MAX | |
| A | 0.053 | 0.069 | 1.35 | 1.75 | - |
| A1 | 0.004 | 0.010 | 0.10 | 0.25 | - |
| A2 | - | 0.061 | - | 1.54 | - |
| B | 0.008 | 0.012 | 0.20 | 0.30 | 9 |
| C | 0.007 | 0.010 | 0.18 | 0.25 | - |
| D | 0.386 | 0.394 | 9.81 | 10.00 | 3 |
| E | 0.150 | 0.157 | 3.81 | 3.98 | 4 |
| e | 0.025 BSC | | 0.635 BSC | | - |
| H | 0.228 | 0.244 | 5.80 | 6.19 | - |
| h | 0.0099 | 0.0196 | 0.26 | 0.49 | 5 |
| L | 0.016 | 0.050 | 0.41 | 1.27 | 6 |
| N | 28 | | 28 | | 7 |
| α | 0° | 8° | 0° | 8° | - |

Rev. 1 6/04

Компания «Океан Электроники» предлагает заключение долгосрочных отношений при поставках импортных электронных компонентов на взаимовыгодных условиях!

Наши преимущества:

- Поставка оригинальных импортных электронных компонентов напрямую с производств Америки, Европы и Азии, а так же с крупнейших складов мира;
- Широкая линейка поставок активных и пассивных импортных электронных компонентов (более 30 млн. наименований);
- Поставка сложных, дефицитных, либо снятых с производства позиций;
- Оперативные сроки поставки под заказ (от 5 рабочих дней);
- Экспресс доставка в любую точку России;
- Помощь Конструкторского Отдела и консультации квалифицированных инженеров;
- Техническая поддержка проекта, помощь в подборе аналогов, поставка прототипов;
- Поставка электронных компонентов под контролем ВП;
- Система менеджмента качества сертифицирована по Международному стандарту ISO 9001;
- При необходимости вся продукция военного и аэрокосмического назначения проходит испытания и сертификацию в лаборатории (по согласованию с заказчиком);
- Поставка специализированных компонентов военного и аэрокосмического уровня качества (Xilinx, Altera, Analog Devices, Intersil, Interpoint, Microsemi, Actel, Aeroflex, Peregrine, VPT, Syfer, Eurofarad, Texas Instruments, MS Kennedy, Miteq, Cobham, E2V, MA-COM, Hittite, Mini-Circuits, General Dynamics и др.);

Компания «Океан Электроники» является официальным дистрибьютором и эксклюзивным представителем в России одного из крупнейших производителей разъемов военного и аэрокосмического назначения «JONHON», а так же официальным дистрибьютором и эксклюзивным представителем в России производителя высокотехнологичных и надежных решений для передачи СВЧ сигналов «FORSTAR».



JONHON

«JONHON» (основан в 1970 г.)

Разъемы специального, военного и аэрокосмического назначения:

(Применяются в военной, авиационной, аэрокосмической, морской, железнодорожной, горно- и нефтедобывающей отраслях промышленности)

«FORSTAR» (основан в 1998 г.)

ВЧ соединители, коаксиальные кабели, кабельные сборки и микроволновые компоненты:

(Применяются в телекоммуникациях гражданского и специального назначения, в средствах связи, РЛС, а так же военной, авиационной и аэрокосмической отраслях промышленности).



Телефон: 8 (812) 309-75-97 (многоканальный)

Факс: 8 (812) 320-03-32

Электронная почта: ocean@oceanchips.ru

Web: <http://oceanchips.ru/>

Адрес: 198099, г. Санкт-Петербург, ул. Калинина, д. 2, корп. 4, лит. А