

Open Ended Card Edge: BTB

00-9159



AVX was challenged with increasing the pin count density as well as minimizing the size of the existing coplanar BTB card edge connector for linear strip lighting. The current product is a 2.0mm with single contacts that straddle the PCB to make electrical connection on both the top and bottom side of the board. By simply changing the contacts to a double sided configuration (separate contacts for both the top and bottom of the PCB), AVX was able to double the pin count in the same 2.0mm pitch with minimal to no impact on the electrical performance of the connector. Reducing the size of the connector required a complete new design as the target was a 4p connector with a total length of 4.0mm. To achieve this, AVX removed the end walls and then added a center support/keying rib to pre-align the PCB during mating. This rib then holds the PCB in the proper functional location.

The new family of connectors is available with contact sizes of 4, 6, 8 and 10 positions, doubling the current products range. The current rating will be 3A for the 4p and 6p, and then drop to 2.5A for the 8p and 10p connector. The connector supports the standard 1.6mm PCB thickness.

This new connector provides the highest density to reliably connect two in-line PCB's together in the most cost effective assembled solution. More importantly, the increased pin count allows for more flexibility in mixing and matching power and signal lines.

APPLICATIONS

- Linear LED strip lighting
- Commercial/Industrial co-planar or extended card applications
- Reference Product Specification 201-01-144

FEATURES AND BENEFITS

- Miniaturized size, achieves 1.0mm in length for each number of contacts (4p = 4.0mm)
- Double Ended/Double Sided contacts for increased pin count density on standard 1.6mm thick PCB's
- Central polarizing/location rib assures proper mating and PCB location
- High current capabilities: 3A; 4p/6p and 2.5A; 8p/10p
- Economical high force Tin-to-Tin contact interface

ELECTRICAL

- Current Rating: 3.0 amps 4p/6p and 2.5 amps 8p/10p
- Voltage Rating: 300 VAC

ENVIRONMENTAL

- Operating Temperature: -40°C to +125°C

MECHANICAL

- Insulator Material: Nylon 46: UL94VO
- Contact Material: Phosphor Bronze
- Plating: Tin over Nickel
- Durability: 5 Cycles

HOW TO ORDER

00	9159	00X	0	61	X	1	X																								
Prefix	Series	Number of Ways	Single Part PCB Strip Connector	PCB Thickness 61 = Open Ended PCB Thickness 1.6-±0.10	Insulator Color	Packaging Options 1 = Bag	Plating Option 6 = Pure Tin all over 1 = Gold Flash																								
		<table border="1"> <thead> <tr> <th>Code</th> <th>No of Ways</th> <th>Details</th> </tr> </thead> <tbody> <tr> <td>004</td> <td>4</td> <td>Page 2</td> </tr> <tr> <td>006</td> <td>6</td> <td>Page 3</td> </tr> <tr> <td>008</td> <td>8</td> <td>Page 4</td> </tr> <tr> <td>010</td> <td>10</td> <td>Page 5</td> </tr> </tbody> </table>	Code	No of Ways	Details	004	4	Page 2	006	6	Page 3	008	8	Page 4	010	10	Page 5			<table border="1"> <thead> <tr> <th>Code</th> <th>Color</th> <th>Application</th> </tr> </thead> <tbody> <tr> <td>8</td> <td>Black</td> <td>Special Order</td> </tr> <tr> <td>9</td> <td>White</td> <td>Standard</td> </tr> </tbody> </table>	Code	Color	Application	8	Black	Special Order	9	White	Standard		
Code	No of Ways	Details																													
004	4	Page 2																													
006	6	Page 3																													
008	8	Page 4																													
010	10	Page 5																													
Code	Color	Application																													
8	Black	Special Order																													
9	White	Standard																													

Certification: UL File #E90723



Open Ended Card Edge: BTB

00-9159

4 WAY SINGLE PART PCB STRIP CONNECTOR – OPEN ENDED

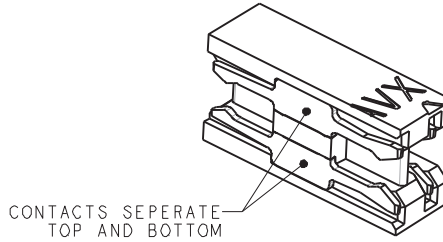
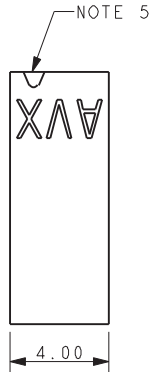

SECTION VIEW THROUGH CONTACT

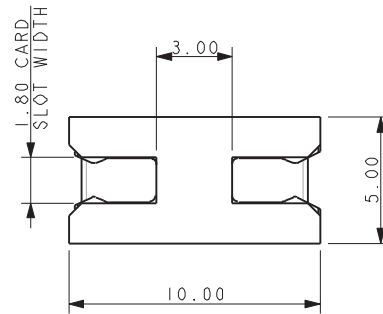
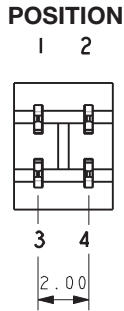

NOTES:

1. INSULATOR MATERIAL NYLON 46, UL94 V-0.
COLOR REFER TO PAGE 1.
2. CONTACT MATERIAL COPPER ALLOY, TIN PLATED
3. PARTS TO BE SUPPLIED IN BAGS, 1000 PIECES PER BAG.
4. GENERAL TOLERANCE $\pm 0.20\text{MM}$ UNLESS STATED.
5. ARROW ADJACENT TO CONTACT POSITION 1.
6. PCB PAD, TIN PLATED OR TIN PLATED WITH GOLD FLASH.
7. FURTHER DETAILS REFER TO ELCO SPECIFICATION 201-01-144.

SUGGESTED PCB LAYOUT

PADS THE SAME UPPER AND LOWER FACES
PCB THICKNESS $1.60 \pm 0.10\text{MM}$ (OVER PADS)

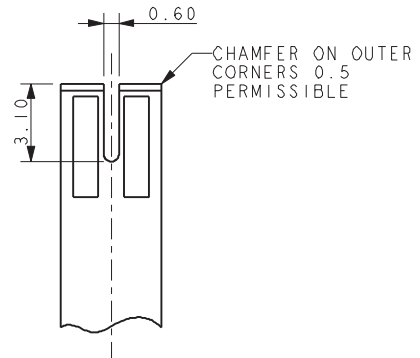
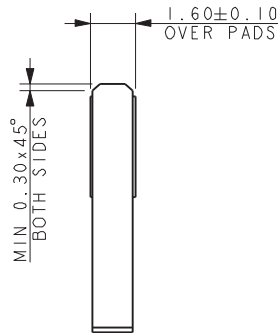
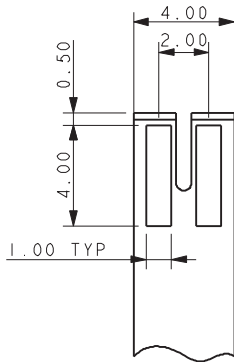

6 WAY SINGLE PART PCB STRIP CONNECTOR – OPEN ENDED

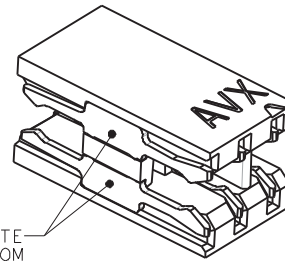
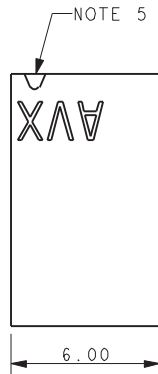

CONTACTS SEPERATE
TOP AND BOTTOM

SECTION VIEW THROUGH CONTACT

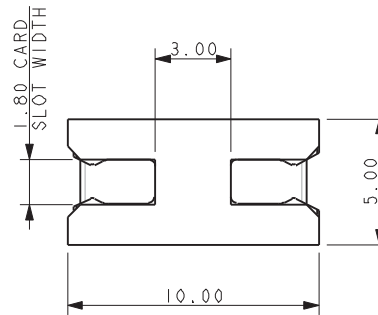
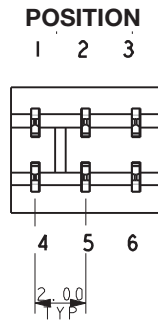

NOTES:

1. INSULATOR MATERIAL NYLON 46, UL94 V-0.
COLOR REFER TO PAGE 1.
2. CONTACT MATERIAL COPPER ALLOY, TIN PLATED
3. PARTS TO BE SUPPLIED IN BAGS, 1000 PIECES PER BAG.
4. GENERAL TOLERANCE $\pm 0.20\text{MM}$ UNLESS STATED.
5. ARROW ADJACENT TO CONTACT POSITION 1.
6. PCB PAD, TIN PLATED OR TIN PLATED WITH GOLD FLASH.
7. FURTHER DETAILS REFER TO ELCO SPECIFICATION 201-01-144.

SUGGESTED PCB LAYOUT

PADS THE SAME UPPER AND LOWER FACES
PCB THICKNESS $1.60 \pm 0.10\text{MM}$ (OVER PADS)

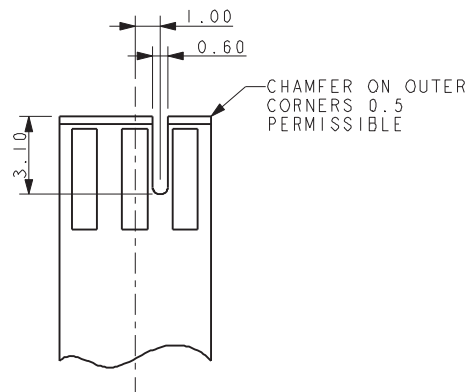
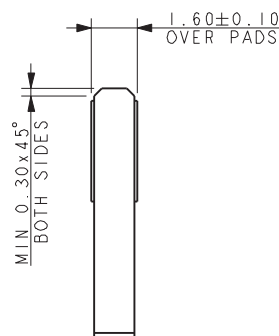
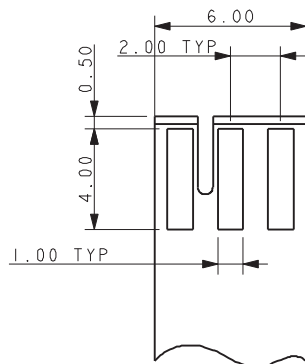

Open Ended Card Edge: BTB

00-9159

8 WAY SINGLE PART PCB STRIP CONNECTOR – OPEN ENDED

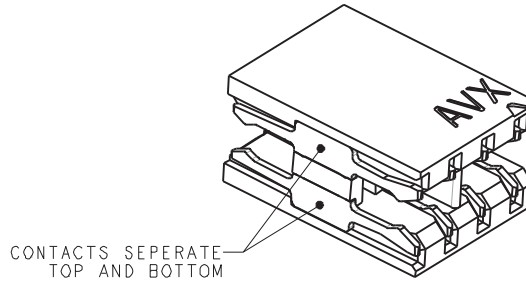

SECTION VIEW THROUGH CONTACT

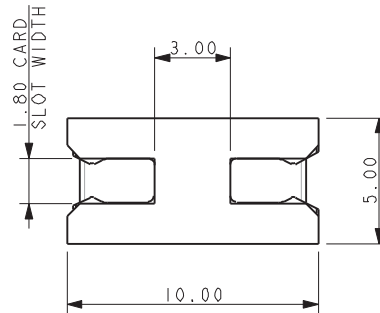
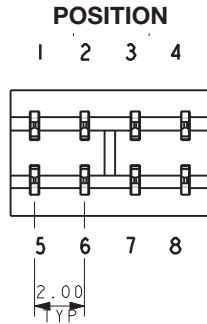

NOTES:

1. INSULATOR MATERIAL NYLON 46, UL94 V-0. COLOR REFER TO PAGE 1.
2. CONTACT MATERIAL COPPER ALLOY, TIN PLATED
3. PARTS TO BE SUPPLIED IN BAGS, 1000 PIECES PER BAG.
4. GENERAL TOLERANCE ± 0.20 MM UNLESS STATED.
5. ARROW ADJACENT TO CONTACT POSITION 1.
6. PCB PAD, TIN PLATED OR TIN PLATED WITH GOLD FLASH.
7. FURTHER DETAILS REFER TO ELCO SPECIFICATION 201-01-144.

SUGGESTED PCB LAYOUT

PADS THE SAME UPPER AND LOWER FACES

PCB THICKNESS 1.60 ± 0.10 MM (OVER PADS)

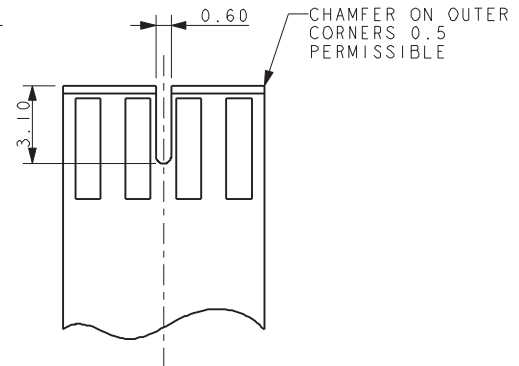
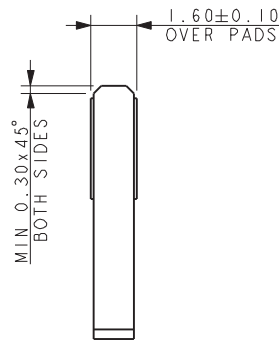
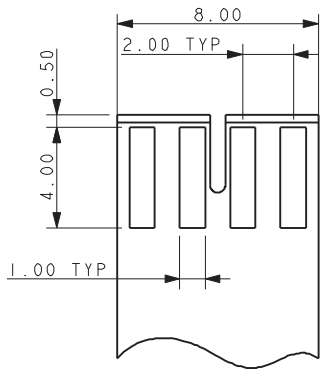

Open Ended Card Edge: BTB

00-9159

10 WAY SINGLE PART PCB STRIP CONNECTOR – OPEN ENDED

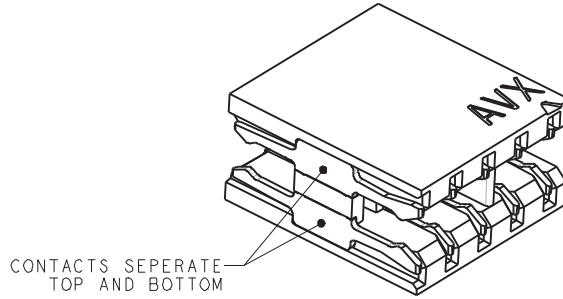
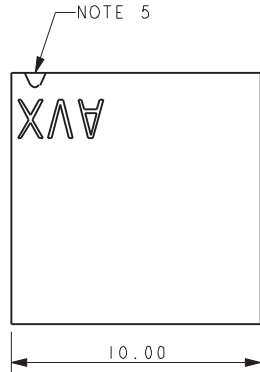

SECTION VIEW THROUGH CONTACT

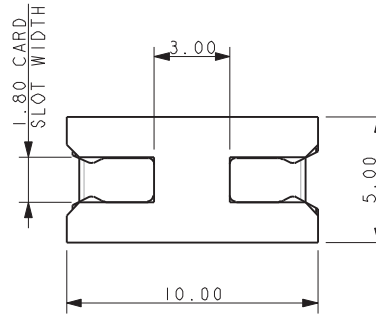
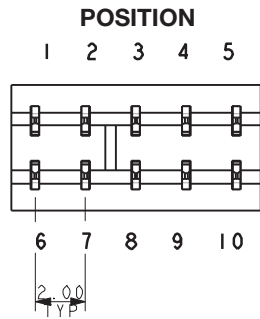

NOTES:

1. INSULATOR MATERIAL NYLON 46, UL94 V-0. COLOR REFER TO PAGE 1.
2. CONTACT MATERIAL COPPER ALLOY, TIN PLATED
3. PARTS TO BE SUPPLIED IN BAGS, 1000 PIECES PER BAG.
4. GENERAL TOLERANCE $\pm 0.20\text{MM}$ UNLESS STATED.
5. ARROW ADJACENT TO CONTACT POSITION 1.
6. PCB PAD, TIN PLATED OR TIN PLATED WITH GOLD FLASH.
7. FURTHER DETAILS REFER TO ELCO SPECIFICATION 201-01-144.

SUGGESTED PCB LAYOUT

PADS THE SAME UPPER AND LOWER FACES
PCB THICKNESS $1.60 \pm 0.10\text{MM}$ (OVER PADS)

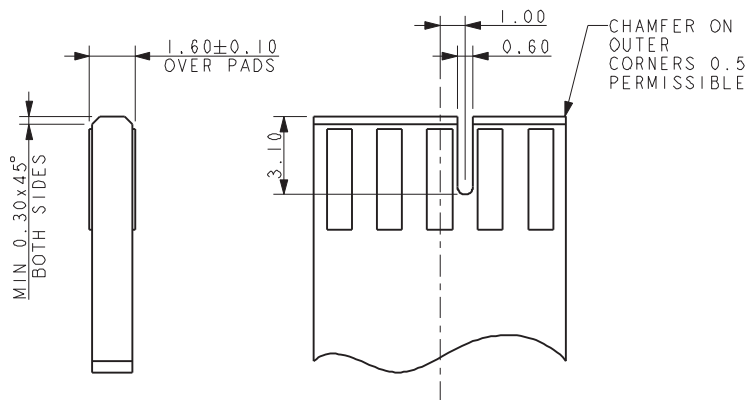
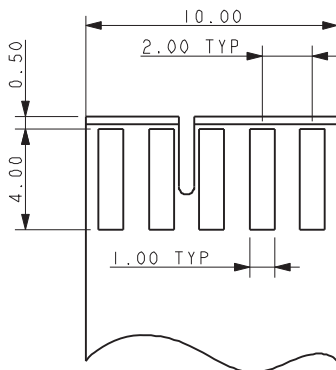

Компания «Океан Электроники» предлагает заключение долгосрочных отношений при поставках импортных электронных компонентов на взаимовыгодных условиях!

Наши преимущества:

- Поставка оригинальных импортных электронных компонентов напрямую с производств Америки, Европы и Азии, а так же с крупнейших складов мира;
- Широкая линейка поставок активных и пассивных импортных электронных компонентов (более 30 млн. наименований);
- Поставка сложных, дефицитных, либо снятых с производства позиций;
- Оперативные сроки поставки под заказ (от 5 рабочих дней);
- Экспресс доставка в любую точку России;
- Помощь Конструкторского Отдела и консультации квалифицированных инженеров;
- Техническая поддержка проекта, помощь в подборе аналогов, поставка прототипов;
- Поставка электронных компонентов под контролем ВП;
- Система менеджмента качества сертифицирована по Международному стандарту ISO 9001;
- При необходимости вся продукция военного и аэрокосмического назначения проходит испытания и сертификацию в лаборатории (по согласованию с заказчиком);
- Поставка специализированных компонентов военного и аэрокосмического уровня качества (Xilinx, Altera, Analog Devices, Intersil, Interpoint, Microsemi, Actel, Aeroflex, Peregrine, VPT, Syfer, Eurofarad, Texas Instruments, MS Kennedy, Miteq, Cobham, E2V, MA-COM, Hittite, Mini-Circuits, General Dynamics и др.);

Компания «Океан Электроники» является официальным дистрибьютором и эксклюзивным представителем в России одного из крупнейших производителей разъемов военного и аэрокосмического назначения «JONHON», а так же официальным дистрибьютором и эксклюзивным представителем в России производителя высокотехнологичных и надежных решений для передачи СВЧ сигналов «FORSTAR».



JONHON

«JONHON» (основан в 1970 г.)

Разъемы специального, военного и аэрокосмического назначения:

(Применяются в военной, авиационной, аэрокосмической, морской, железнодорожной, горно- и нефтедобывающей отраслях промышленности)

«FORSTAR» (основан в 1998 г.)

ВЧ соединители, коаксиальные кабели, кабельные сборки и микроволновые компоненты:

(Применяются в телекоммуникациях гражданского и специального назначения, в средствах связи, РЛС, а так же военной, авиационной и аэрокосмической отраслях промышленности).



Телефон: 8 (812) 309-75-97 (многоканальный)

Факс: 8 (812) 320-03-32

Электронная почта: ocean@oceanchips.ru

Web: <http://oceanchips.ru/>

Адрес: 198099, г. Санкт-Петербург, ул. Калинина, д. 2, корп. 4, лит. А