

**THS7CHG
Battery Charger**

Instructions

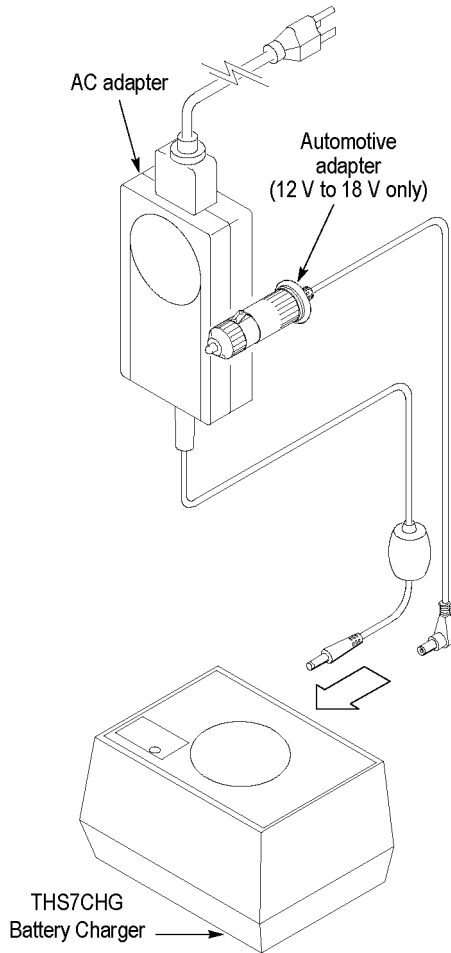

070-9309-04



Using the Battery Charger

The THS7CHG is for use with the THS7BAT battery packs.

1. Insert the plug on the adapter cable into the jack on the battery charger.
2. Connect the adapter to the power source.
3. Insert the battery pack into the battery charger. LED indicates state of the battery charge:
 Steady red - charging at full rate
 Steady green - ready, trickle charging
 Flashing red - battery problem, replace battery

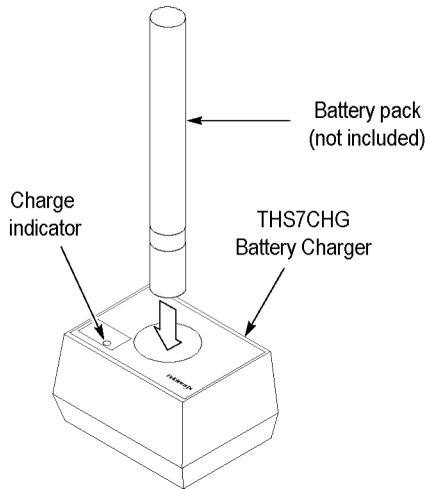

CAUTION. To avoid damage to the battery charger or AC adapter, do not substitute another AC adapter in place of the one provided or use the AC adapter to power another instrument.

Table 1: Specifications

Voltage Input	12 to 18 VDC
Input Connector Size	2.1 mm
Input Polarity	Center conductor positive
Automotive Adapter Input	For use with 12 VDC, negative ground systems only Do not operate the THS7CHG Battery Charger with the automotive adapter while cranking the vehicle engine or troubleshooting the vehicle electrical system
Charging Information	Charge in a dry location, not to exceed 45 °C. The THS7CHG Battery Charger will not overcharge the THS7BAT battery pack A fully discharged battery pack typically recharges in 2 hours. A partially discharged battery pack recharges in less time To maintain peak performance of NiCd batteries, it is recommended to fully discharge them before recharging
Charge Time	2 hours, typical (fully discharged battery pack)
Safety	Only charge THS7BAT battery packs in the THS7CHG Battery Charger NiCd batteries must be recycled or disposed of properly
Cleaning	Clean with a soft cloth dampened with water or a 75% isopropyl alcohol solution
Replaceable Parts	There are no user-replaceable parts inside the THS7CHG Battery Charger

Table 2: Accessories

Power supply; external; AC-DC 18 W, 100-220 VAC 47-63 HZ input, 12 VDC 1.5 A output (Standard)	Order Tektronix part number 119-7285-XX
North America, Power Cord (Standard A0)	Order Tektronix part number 161-0066-00
Universal Euro, Power Cord (Option A1)	Order Tektronix part number 161-0066-09
China, Power Cord (Option A10)	Order Tektronix part number 161-0304-00
U.K., Power Cord (Option A2)	Order Tektronix part number 161-0066-10
Australia, Power Cord (Option A3)	Order Tektronix part number 161-0066-13
Japan, Power Cord (Option A6)	Order Tektronix part number 161-0298-00
Automotive Adapter (5A, 250 V fuse included)	Order Tektronix part number 174-1734-01
Battery Pack (Not included with the THS7CHG Battery Charger)	Order THS7BAT

Equipment Recycling. Production of this equipment required the extraction and use of natural resources. The equipment may contain substances that could be harmful to the environment or human health if improperly handled at the product's end of life. In order to avoid release of such substances into the environment and to reduce the use of natural resources, we encourage you to recycle this product in an appropriate system that will ensure that most of the materials are reused or recycled appropriately.



Equipment Recycling. This product complies with the European Union's requirements according to Directive 2002/96/EC on waste electrical and electronic equipment (WEEE). For more information about recycling options, check the Support/Service section of the Tektronix Web site (www.tektronix.com).

Battery Recycling. This product may be accompanied by a Nickel Cadmium (NiCd) or lithium ion (Li-ion) rechargeable battery, which must be recycled or disposed of properly. Please properly dispose of or recycle the battery according to local government regulations.

Compliance Information

This section lists the EMC (electromagnetic compliance), safety, and environmental standards with which the instrument complies.

EC Declaration of Conformity – EMC. Meets intent of Directive 2004/108/EC for Electromagnetic Compatibility. Compliance was demonstrated to the following specifications as listed in the Official Journal of the European Communities:

EN 61326-1 2006. EMC requirements for electrical equipment for measurement, control, and laboratory use.^{1 2}

- 1 This product is intended for use in nonresidential areas only. Use in residential areas may cause electromagnetic interference.
 - 2 Emissions which exceed the levels required by this standard may occur when this equipment is connected to a test object.
- CISPR 11:2003. Radiated and conducted emissions, Group 1, Class A
 - IEC 61000-4-2:2001. Electrostatic discharge immunity
 - IEC 61000-4-3:2002. RF electromagnetic field immunity
 - IEC 61000-4-4:2004. Electrical fast transient / burst immunity
 - IEC 61000-4-5:2001. Power line surge immunity

- IEC 61000-4-6:2003. Conducted RF immunity
- IEC 61000-4-11:2004. Voltage dips and interruptions immunity

EN 61000-3-2:2006. AC power line harmonic emissions

EN 61000-3-3:1995. Voltage changes, fluctuations, and flicker

European Contact.

Tektronix UK, Ltd.
Western Peninsula
Western Road
Bracknell, RG12 1RF
United Kingdom

Australia / New Zealand Declaration of Conformity – EMC. Complies with the EMC provision of the Radiocommunications Act per the following standard, in accordance with ACMA:

- CISPR 11:2003. Radiated and Conducted Emissions, Group 1, Class A, in accordance with EN 61326-1:2006.

Warranty Information

For warranty information, go to www.tektronix.com/service, and then use the provided links to search for your product's warranty.

Contacting Tektronix

Tektronix, Inc.
14200 SW Karl Braun Drive
PO Box 500
Beaverton, OR 97077
USA

For product information, sales, service, and technical support:

- In North America, call 1-800-833-9200.
- Worldwide, visit www.tektronix.com to find contacts in your area.

Mouser Electronics

Authorized Distributor

Click to View Pricing, Inventory, Delivery & Lifecycle Information:

[Tektronix:](#)

[THS7CHG](#) [THSCHG](#)

Компания «Океан Электроники» предлагает заключение долгосрочных отношений при поставках импортных электронных компонентов на взаимовыгодных условиях!

Наши преимущества:

- Поставка оригинальных импортных электронных компонентов напрямую с производств Америки, Европы и Азии, а так же с крупнейших складов мира;
- Широкая линейка поставок активных и пассивных импортных электронных компонентов (более 30 млн. наименований);
- Поставка сложных, дефицитных, либо снятых с производства позиций;
- Оперативные сроки поставки под заказ (от 5 рабочих дней);
- Экспресс доставка в любую точку России;
- Помощь Конструкторского Отдела и консультации квалифицированных инженеров;
- Техническая поддержка проекта, помощь в подборе аналогов, поставка прототипов;
- Поставка электронных компонентов под контролем ВП;
- Система менеджмента качества сертифицирована по Международному стандарту ISO 9001;
- При необходимости вся продукция военного и аэрокосмического назначения проходит испытания и сертификацию в лаборатории (по согласованию с заказчиком);
- Поставка специализированных компонентов военного и аэрокосмического уровня качества (Xilinx, Altera, Analog Devices, Intersil, Interpoint, Microsemi, Actel, Aeroflex, Peregrine, VPT, Syfer, Eurofarad, Texas Instruments, MS Kennedy, Miteq, Cobham, E2V, MA-COM, Hittite, Mini-Circuits, General Dynamics и др.);

Компания «Океан Электроники» является официальным дистрибьютором и эксклюзивным представителем в России одного из крупнейших производителей разъемов военного и аэрокосмического назначения «JONHON», а так же официальным дистрибьютором и эксклюзивным представителем в России производителя высокотехнологичных и надежных решений для передачи СВЧ сигналов «FORSTAR».



JONHON

«JONHON» (основан в 1970 г.)

Разъемы специального, военного и аэрокосмического назначения:

(Применяются в военной, авиационной, аэрокосмической, морской, железнодорожной, горно- и нефтедобывающей отраслях промышленности)

«FORSTAR» (основан в 1998 г.)

ВЧ соединители, коаксиальные кабели, кабельные сборки и микроволновые компоненты:

(Применяются в телекоммуникациях гражданского и специального назначения, в средствах связи, РЛС, а так же военной, авиационной и аэрокосмической отраслях промышленности).



Телефон: 8 (812) 309-75-97 (многоканальный)

Факс: 8 (812) 320-03-32

Электронная почта: ocean@oceanchips.ru

Web: <http://oceanchips.ru/>

Адрес: 198099, г. Санкт-Петербург, ул. Калинина, д. 2, корп. 4, лит. А