

Many Models Including Roller Lever Switches are Only 16-mm Thick with Connector

- New center roller lever models that enable ganged mounting of up to 6 Switches.
- Cable connectors for easy Switch replacement.
- Triple-seal construction to provide IEC IP67 degree of protection.
- Operation indicators available for easy monitoring (standard indicator is lit when Switch is not operating).
- Approved by UL and CSA.
(Ask your OMRON representative for Information on approved models.)



 Be sure to read *Safety Precautions* on page 7 to 8 and *Safety Precautions for All Limit Switches*.

Model Number Structure

Model Number Legend (Not all combinations are possible. Ask your OMRON representative for details.)

D4CC-□0□□
(1) (2)

(1) Rated Current

- 1 : 1 A at 125 VAC
- 2 : 1 A at 125 VAC (with LED indicator)
- 3 : 1 A at 30 VDC
- 4 : 1 A at 30 VDC (with LED indicator)









(2) Actuator

- 01 : Pin plunger
- 02 : Roller plunger
- 03 : Crossroller plunger
- 24 : Roller lever
- 31 : Sealed pin plunger
- 32 : Sealed roller plunger
- 33 : Sealed crossroller plunger
- 50 : Plastic rod
- 60 : Center roller lever

Ordering Information

Switches

Limit Switches

Actuator	Ratings LED indicator	1 A at 125 VAC		1 A at 30 VDC	
		Without indicator	With indicator	Without indicator	With indicator
		Model	Model	Model	Model
Pin plunger		D4CC-1001	D4CC-2001	D4CC-3001	D4CC-4001
Roller plunger		D4CC-1002	D4CC-2002	D4CC-3002	D4CC-4002
Crossroller plunger		D4CC-1003	D4CC-2003	D4CC-3003	D4CC-4003
High-sensitivity roller lever		D4CC-1024	D4CC-2024	D4CC-3024	D4CC-4024
Sealed pin plunger		D4CC-1031	D4CC-2031	D4CC-3031	D4CC-4031
Sealed roller plunger		D4CC-1032	D4CC-2032	D4CC-3032	D4CC-4032
Sealed crossroller plunger		D4CC-1033	---	D4CC-3033	D4CC-4033
Plastic rod		D4CC-1050	D4CC-2050	D4CC-3050	D4CC-4050
Center roller lever		D4CC-1060	D4CC-2060	D4CC-3060	D4CC-4060

Note: 1. Ask your OMRON representative for Information on approved models.
 2. The meaning of suffix codes in the D4CC model numbers is different from that in the D4C model numbers.
 3. Refer to the following table for cable plugs.

Applicable Cables

Appearance	No. of conductors	Type Cable length	For AC	For DC
			Model	Model
	4	1 m	XS2F-A421-C90-A	XS2F-D421-C80-A
		2 m	XS2F-A421-D90-A	XS2F-D421-D80-A
		5 m	XS2F-A421-G90-A	XS2F-D421-G80-A
		10 m	XS2F-A421-J90-A	XS2F-D421-J80-A

Special Mounting Plate (Order Separately)

It is possible to replace an WL Limit Switch with a D4CC Limit Switch mounted on this plate without changing the position of the dog or cam.

List of Replaceable Models

WL model (Actuator)	D4CC model (Actuator)	Plate
WLD (Top plunger)	→ D4CC-□001 (Plunger)	D4C-P001
WLD2 (Top roller plunger)	→ D4CC-□002 (Roller plunger)	D4C-P002
WLG2 (Roller lever)	→ D4CC-□024 (Roller lever)	D4C-P020

Example of Replacement

Note: The position of the dog remains unchanged.

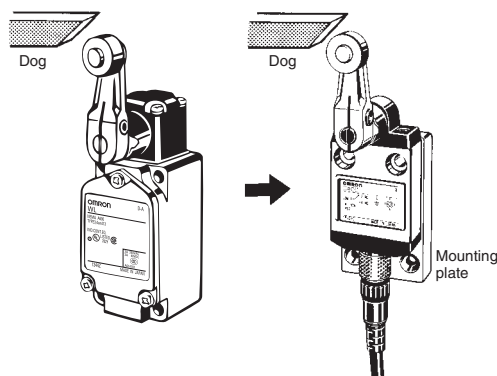

Specifications

Approved Standards

Agency	Standard	File No.
UL	UL508	E76675
CSA	CSA C22.2 No. 14	LR45746

Ratings

Rated voltage	Non-inductive load (A)				Inductive load (A)			
	Resistive load		Lamp load		Inductive load		Motor load	
	NC	NO	NC	NO	NC	NO	NC	NO
125 VAC	1	1	1	0.7	1	1	1	1
30 VDC	1	1	1	1	1	1	1	1

Note: 1. The above current ratings are for steady-state current.
 2. Inductive loads have a power factor of 0.4 min. (AC) and a time constant of 7 ms max. (DC).
 3. Lamp loads have an inrush current of 10 times the steady-state current.
 4. Motor loads have an inrush current of 6 times the steady-state current.

D4CC-3, D4CC-4, 1 A at 30 VDC

Inrush current	NC	5 A max.
	NO	2.5 A max.

Approved Standard Ratings

UL/CSA

D4CC-1, D4CC-2

D150

Rated voltage	Carry current	Current (A)		Volt-amperes (VA)	
		Make	Break	Make	Break
120 VAC	1.0 A	3.6	0.6	432	72

Characteristics

Degree of protection		IP67
Durability *1	Mechanical	10,000,000 operations min.
	Electrical	200,000 operations min. (1 A at 125 VAC, resistive load)
Operating speed		0.1 mm/s to 0.5 m/s (in case of plunger) 1 mm/s to 1 m/s (in case of roller lever)
Operating frequency	Mechanical	120 operations/min
	Electrical	30 operations/min
Rated frequency		50/60 Hz
Insulation resistance		100 MΩ min. (at 500 VDC)
Contact resistance (initial)		100 mΩ max.
Dielectric strength	Between terminals of same polarity	1,000 VAC, 50/60 Hz for 1 min
	Between current-carrying metal parts and ground	1,500 VAC, 50/60 Hz for 1 min
	Between each terminal and non-current-carrying metal part	1,500 VAC, 50/60 Hz for 1 min
Vibration resistance	Malfunition	10 to 55 Hz, 1.5-mm double amplitude *2
Shock resistance	Destruction	1,000 m/s ² min.
	Malfunition	500 m/s ² min. *2
Ambient operating temperature		-10°C to +70°C (with no icing)
Ambient operating humidity		35% to 95%RH
Weight		Approx. 120 g (in the case of D4CC-1002)

Note: The above figures are initial values.

*1. The values are calculated at an operating temperature of +5°C to +35°C, and an operating humidity of 40% to 70%RH. Contact your OMRON sales representative for more detailed information on other operating environments.

*2. Excluding plastic rod models.

Leakage Current for Switches with Indicators

The leakage current and resistance of Switches with indicators are as follows:

Item	Model	D4CC-2□□□	D4CC-4□□□
Voltage		125 VAC	30 VDC
Leakage current		1.0 mA	1.0 mA
Resistive value		150 kΩ	30 kΩ

Structure and Nomenclature

Structure

Center Roller Lever Models with Indicator

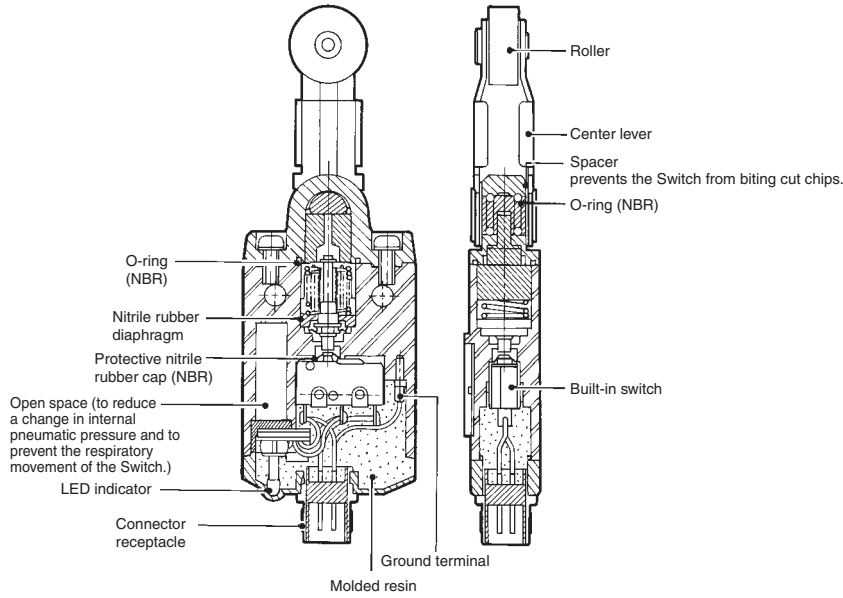

Contact Form

AC Switches (D4CC-10□□, 20□□)

Without Operation Indicator

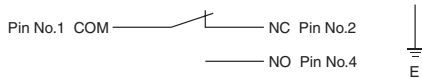

With Operation Indicator (Lit when Not Actuated) *1

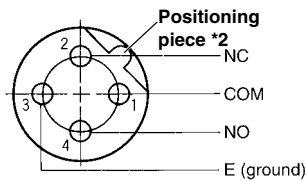
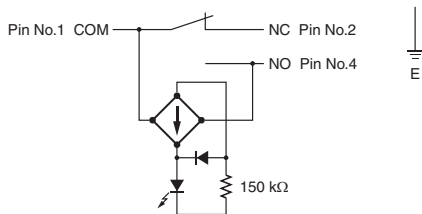

DC Switches (D4CC-30□□, 40□□)

Without Operation Indicator

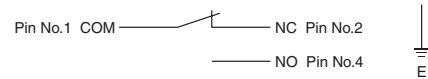

With Operation Indicator (Lit when Not Actuated) *1

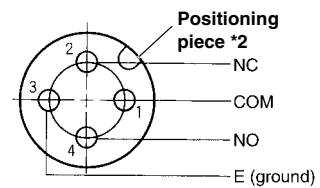
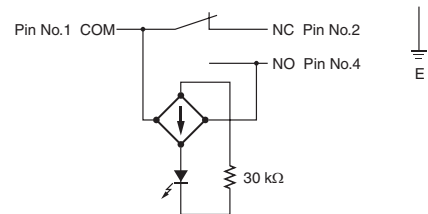

*1. "Lit when not actuated" means that when the actuator is in the free position, the indicator is lit, and when the actuator is turned or pushed and the contact comes into contact with the NO side, the indicator turns OFF.

*2. The position of the positioning piece is not always the same. If using an L-shaped connector causes problems in application, use a straight connector.

Connections

Note: Colors in parentheses are the previous wire colors. Wire colors have been changed accompanying changes in standards.

For AC

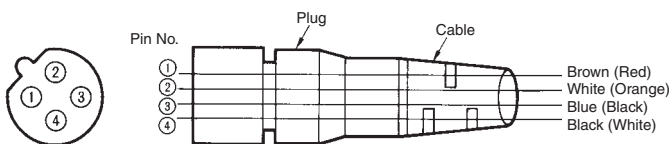

For DC

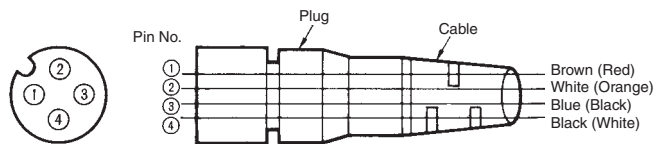

Dimensions and Operating Characteristics

Switches

Limit Switches The □ in each model number is replaced with the code expressing the rated load of the model. Refer to *Model Number Legend*.

Pin Plunger D4CC-□001

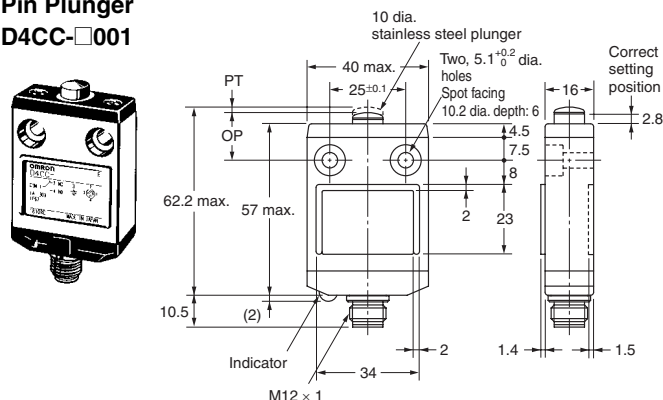

Roller Lever D4CC-□024

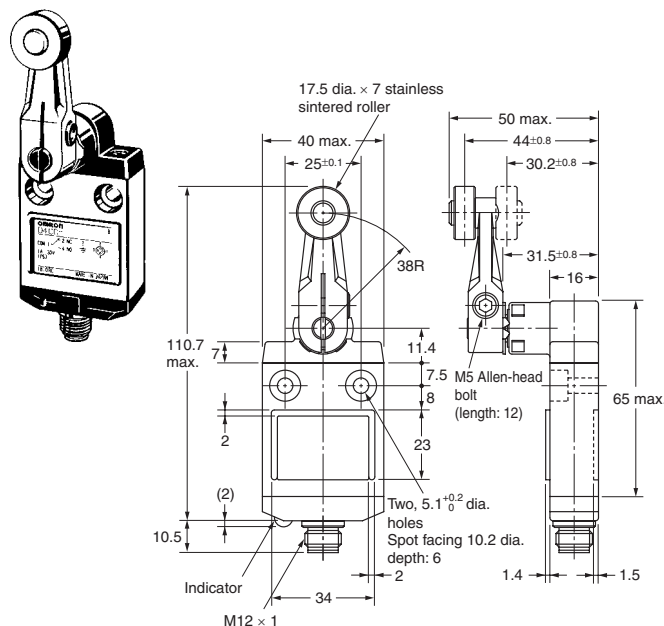

Roller Plunger D4CC-□002

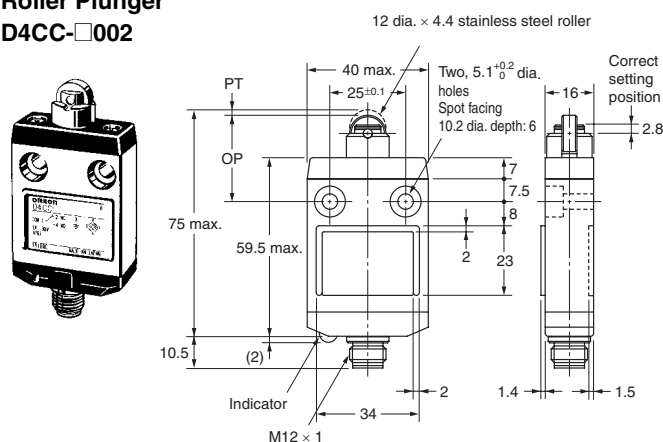

Sealed Pin Plunger D4CC-□031

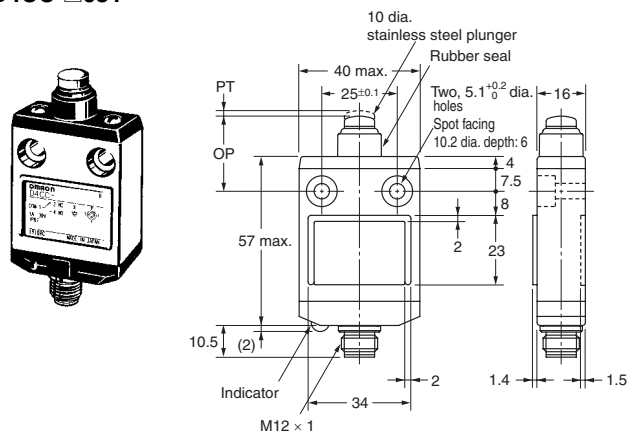

Crossroller Plunger D4CC-□003

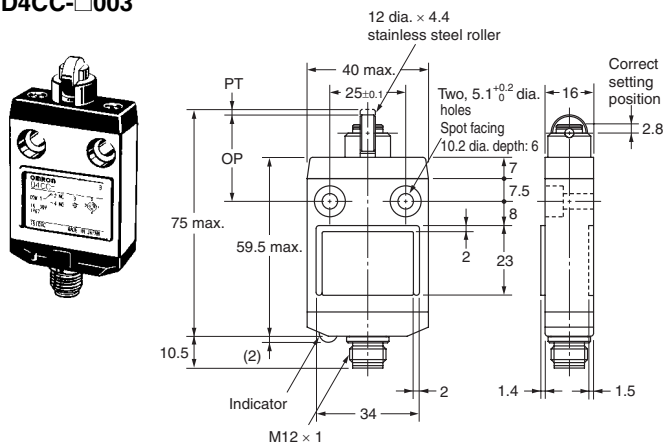

Note: Unless otherwise specified, a tolerance of ± 0.4 mm applies to all dimensions.

Operating Characteristics	Model	D4CC-□001	D4CC-□002	D4CC-□003	D4CC-□024	D4CC-□031
Operating force	OF max.	11.77 N	11.77 N	11.77 N	5.69 N	17.65 N
Release force	RF min.	4.41 N	4.41 N	4.41 N	1.47 N	4.41 N
Pretravel	PT max.	1.8 mm	1.8 mm	1.8 mm	$10^{\circ} \pm 3^{\circ}$	1.8 mm
Overtravel	OT min.	3 mm	3 mm	3 mm	50°	3 mm
Movement Differential	MD max.	0.2 mm	0.2 mm	0.2 mm	3°	0.2 mm
Operating Position	OP	15.7 ± 1 mm	28.5 ± 1 mm	28.5 ± 1 mm	---	24.9 ± 1 mm
Total travel	TT *	---	---	---	---	(5) mm

* The TT is a reference value.

The □ in each model number is replaced with the code expressing the rated load of the model. Refer to *Model Number Legend*.

Sealed Roller Plunger D4CC-□032

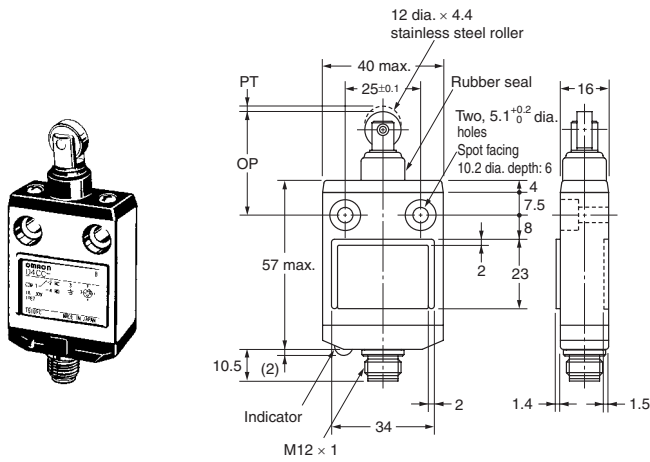

Plastic Rod D4CC-□50

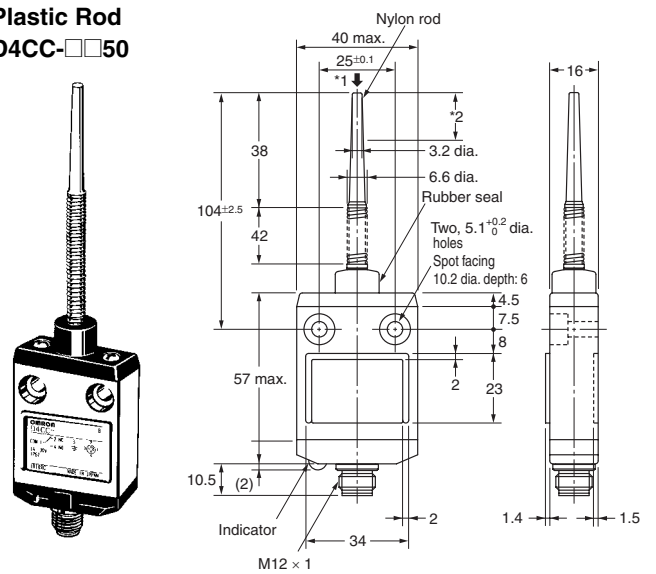

*1. Operation is possible in any direction except parallel to the axis ↓.
*2. The ideal range for operation is between the tip of the rod and 1/3 of the length of the actuator.

Sealed Crossroller Plunger D4CC-□033

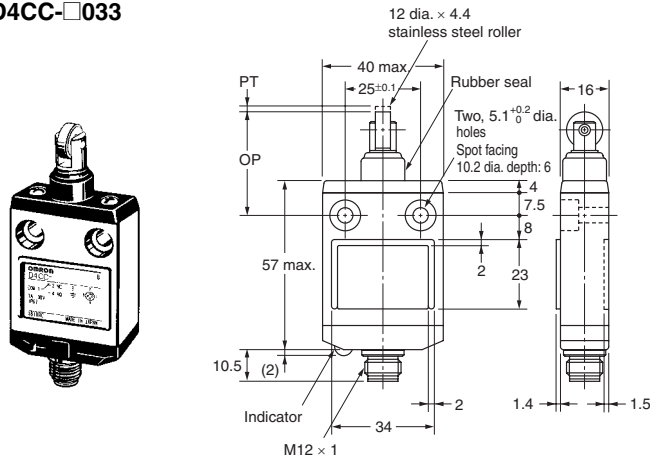

Center Roller Lever D4CC-□60

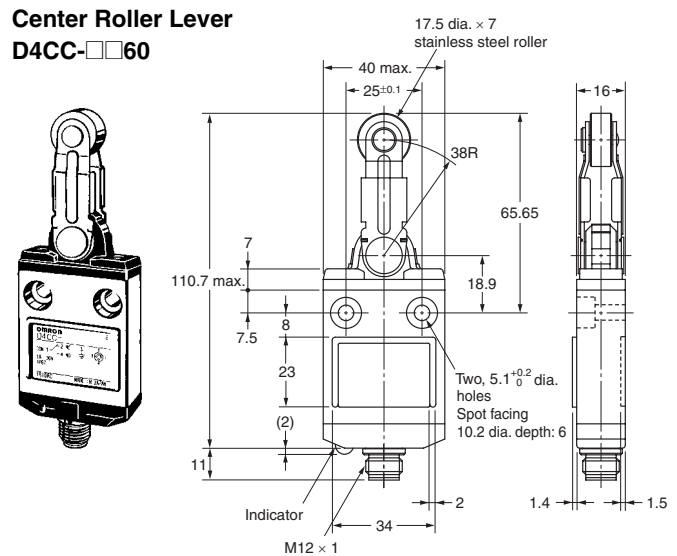

Note: Unless otherwise specified, a tolerance of ± 0.4 mm applies to all dimensions.

Operating Characteristics		Model	D4CC-□032	D4CC-□033	D4CC-□050	D4CC-□060
Operating force	OF	max.	17.65 N	17.65 N	1.47 N	6.67 N
Release force	RF	min.	4.41 N	4.41 N	---	1.47 N
Pretravel	PT	max.	1.8 mm	1.8 mm	15°	10°±3°
Overtravel	OT	min.	3 mm	3 mm	---	50°
Movement Differential	MD	max.	0.2 mm	0.2 mm	---	3°
Operating Position	OP		34.3±1 mm	34.3±1 mm	---	---
Total travel	TT	*	(5) mm	(5) mm	---	---

* The TT is a reference value.

Applicable Cables

Select one of the specified Connector Plugs from the following table.

XS2F-D421-□80-A (For DC)
XS2F-A421-□90-A (For AC)

For AC Model	For DC Model	Cable length (L) (m)
XS2F-A421-C90-A	XS2F-D421-C80-A	1
XS2F-A421-D90-A	XS2F-D421-D80-A	2
XS2F-A421-G90-A	XS2F-D421-G80-A	5
XS2F-A421-J90-A	XS2F-D421-J80-A	10

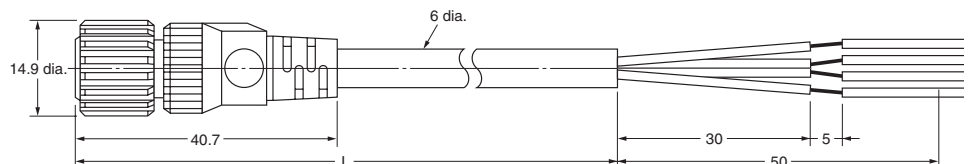
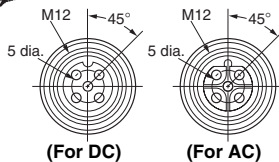
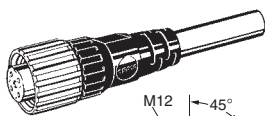

Special Mounting Plates (Limit Switches are not attached to the Plates.)

D4C-P001 (For D4CC-□001)

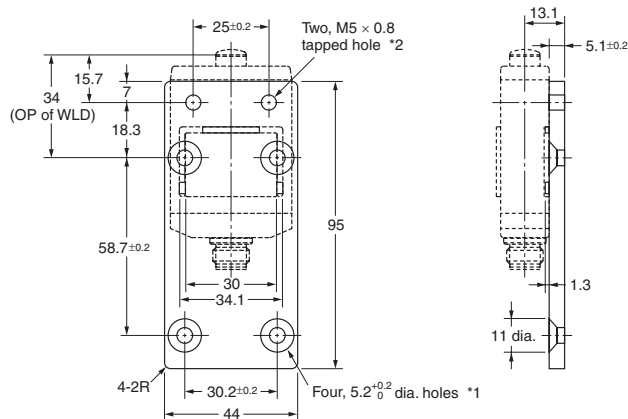
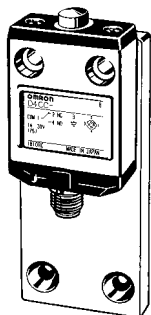

Note: Four hexagonal flat head bolts (M5 × 0.8, length: 10) and two Allen-head bolts (M5 × 0.8, length: 15) are included.

*1. All the holes with 5.2^{+0.2}/₀ dia. must be used with M5 × 10 Allen-head bolts.

*2. All the M5-tapped holes must be used with M5 hexagonal flat head bolts.

D4C-P002 (For D4CC-□002)

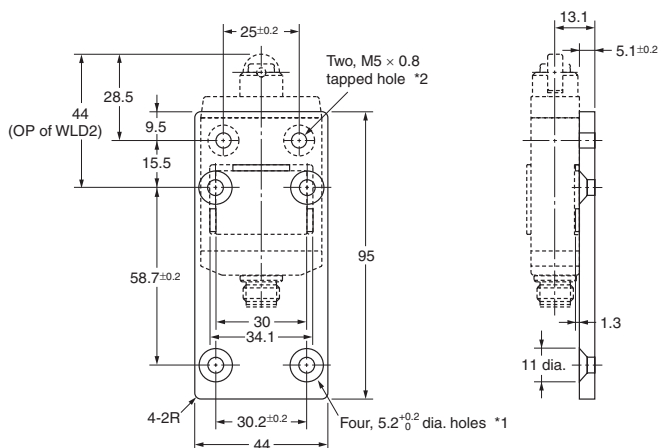
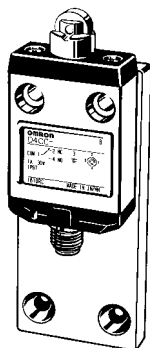

Note: Four hexagonal flat head bolts (M5 × 0.8, length: 10) and two Allen-head bolts (M5 × 0.8, length: 15) are included.

*1. All the holes with 5.2^{+0.2}/₀ dia. must be used with M5 × 10 Allen-head bolts.

*2. All the M5-tapped holes must be used with M5 hexagonal flat head bolts.

D4C-P020 (For D4CC-□024)

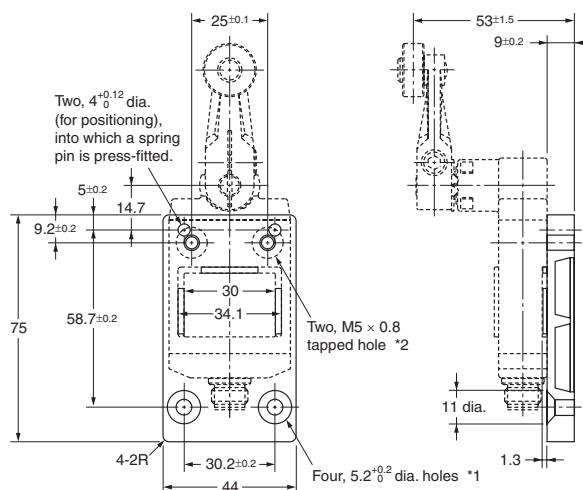
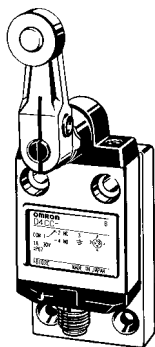

Note: Four hexagonal flat head bolts (M5 × 0.8, length: 10), two Allen-head bolts (M5 × 0.8, length: 15), and two spring pins (4 × 14) are included.

*1. All the holes with 5.2^{+0.2}/₀ dia. must be used with M5 × 10 Allen-head bolts.

*2. All the M5-tapped holes must be used with M5 hexagonal flat head bolts.

Note: Unless otherwise specified, a tolerance of ±0.4 mm applies to all dimensions.

Remarks

There is no difference in mounting pitch between the Mounting Plate and the WL. The mounting depth of the D4CC with the Mounting Plate attached is, however, shorter than that of the panel-mounted WL.

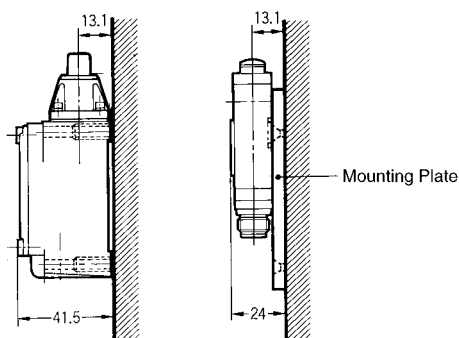

Safety Precautions

Refer to *Safety Precautions for All Limit Switches*.

Precautions for Correct Use

Operating Environment

- Seal material may deteriorate if a Switch is used outdoor or where subject to special cutting oils, solvents, or chemicals. Always appraise performance under actual application conditions and set suitable maintenance and replacement periods.
- Install Switches where they will not be directly subject to cutting chips, dust, or dirt. The Actuator and Switch must also be protected from the accumulation of cutting chips or sludge.



- Constantly subjecting a Switch to vibration or shock can result in wear, which can lead to contact interference with contacts, operation failure, reduced durability, and other problems. Excessive vibration or shock can lead to false contact operation or damage. Install Switches in locations not subject to shock and vibration and in orientations that will not produce resonance.
- The Switches have physical contacts. Using them in environments containing silicon gas will result in the formation of silicon oxide (SiO₂) due to arc energy. If silicon oxide accumulates on the contacts, contact interference can occur. If silicon oil, silicon filling agents, silicon cables, or other silicon products are present near the Switch, suppress arcing with contact protective circuits (surge killers) or remove the source of silicon gas.

Mounting

- Make sure that the plate to which the D4CC is mounted is flat. If the plate is warped or has protruding parts, the D4CC may not malfunction.
- A maximum of 6 Switches may be group-mounted. In this case, pay attention to the mounting direction so that the convex part of the group-mounting guide on one Switch fits into the concave part of the guide on the other Switch as shown in the figure below. For group mounting, the mounting panel must have a thickness (t) of 6 mm min.

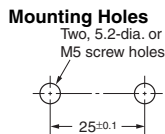

Group Mounting

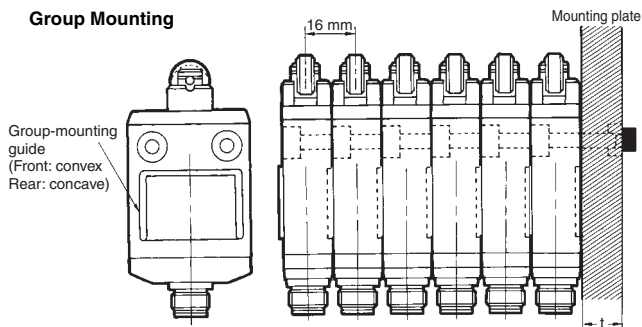

- Be sure to tighten each screw to the proper tightening torque as shown in the table.

No.	Type	Appropriate tightening torque *
(1)	M5 Allen-head bolt	4.90 to 5.88 N·m
(2)	M3.5 head mounting screw	0.78 to 0.88 N·m
(3)	M5 Allen-head bolt	4.90 to 5.88 N·m

* By removing the two screws from the head, the head direction can be rotated 180°. After changing the head direction, re-tighten to the torque specified above. Be careful not to allow any foreign substance to enter the Switch.

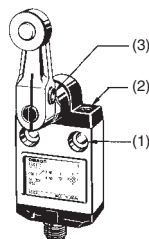

Operation

- Operation method, shapes of cam and dog, operating frequency, and overtravel have a significant effect on the service life and precision of a Limit Switch. For this reason, the dog angle must be 30° max., the surface roughness of the dog must be 6.3S min. and hardness must be Hv400 to 500.
- To allow the plunger-type actuator to travel properly, adjust the dog and cam to the proper setting positions. The proper position is where the plunger groove fits the bushing top.

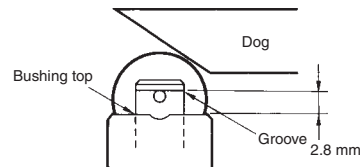

- To allow the roller lever-type actuator to travel properly, adjust the dog and cam so that the arrow head is positioned between the two convex markers as shown below.
- Properly adjust the stroke of the center roller lever along with the dog or cam so that the concave part (A) of the head is located between the convex parts of the head as shown below when the center roller lever is pressed by the dog or cam.

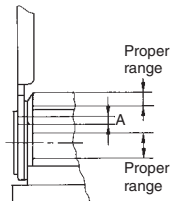
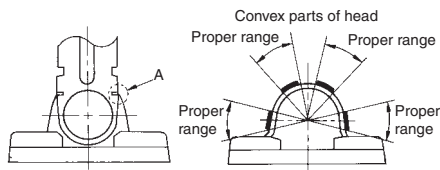
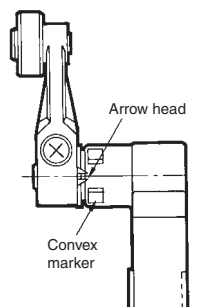

- Refer to the following to adjust the stroke of the lever based on the mounting hole level.

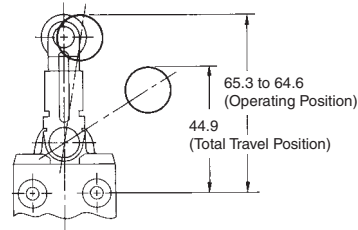

Plug Tightening

- Connect the plug connector (B) to the connector threads (C) of the D4CC. Then firmly turn the plug connector by hand so that the connector threaded portion (C) will be completely covered by the plug connector (B) so that space (A) will be almost 0.

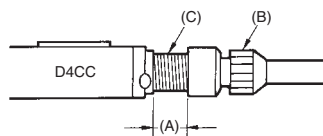

- Do not use any tools, such as pliers, to tighten the plug connector, otherwise the plug connector may become damaged. Make sure, however, that the plug connector is tightened securely, otherwise the rated degree of protection of the D4CC may not be maintained. Furthermore, the plug connector may be loosened by vibration.

Properly Tightened Connector

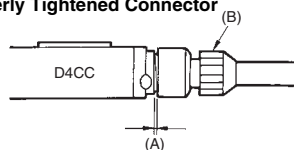

Others

- If failures, such as reset failures, in the plunger model are possible, use a model that has a rubber cap.
- Do not expose the Switch to water exceeding 70°C or use it in steam.

Read and Understand This Catalog

Please read and understand this catalog before purchasing the products. Please consult your OMRON representative if you have any questions or comments.

Warranty and Limitations of Liability

WARRANTY

OMRON's exclusive warranty is that the products are free from defects in materials and workmanship for a period of one year (or other period if specified) from date of sale by OMRON.

OMRON MAKES NO WARRANTY OR REPRESENTATION, EXPRESS OR IMPLIED, REGARDING NON-INFRINGEMENT, MERCHANTABILITY, OR FITNESS FOR PARTICULAR PURPOSE OF THE PRODUCTS. ANY BUYER OR USER ACKNOWLEDGES THAT THE BUYER OR USER ALONE HAS DETERMINED THAT THE PRODUCTS WILL SUITABLY MEET THE REQUIREMENTS OF THEIR INTENDED USE. OMRON DISCLAIMS ALL OTHER WARRANTIES, EXPRESS OR IMPLIED.

LIMITATIONS OF LIABILITY

OMRON SHALL NOT BE RESPONSIBLE FOR SPECIAL, INDIRECT, OR CONSEQUENTIAL DAMAGES, LOSS OF PROFITS OR COMMERCIAL LOSS IN ANY WAY CONNECTED WITH THE PRODUCTS, WHETHER SUCH CLAIM IS BASED ON CONTRACT, WARRANTY, NEGLIGENCE, OR STRICT LIABILITY.

In no event shall the responsibility of OMRON for any act exceed the individual price of the product on which liability is asserted.

IN NO EVENT SHALL OMRON BE RESPONSIBLE FOR WARRANTY, REPAIR, OR OTHER CLAIMS REGARDING THE PRODUCTS UNLESS OMRON'S ANALYSIS CONFIRMS THAT THE PRODUCTS WERE PROPERLY HANDLED, STORED, INSTALLED, AND MAINTAINED AND NOT SUBJECT TO CONTAMINATION, ABUSE, MISUSE, OR INAPPROPRIATE MODIFICATION OR REPAIR.

Application Considerations

SUITABILITY FOR USE

OMRON shall not be responsible for conformity with any standards, codes, or regulations that apply to the combination of products in the customer's application or use of the products.

At the customer's request, OMRON will provide applicable third party certification documents identifying ratings and limitations of use that apply to the products. This information by itself is not sufficient for a complete determination of the suitability of the products in combination with the end product, machine, system, or other application or use.

The following are some examples of applications for which particular attention must be given. This is not intended to be an exhaustive list of all possible uses of the products, nor is it intended to imply that the uses listed may be suitable for the products:

- Outdoor use, uses involving potential chemical contamination or electrical interference, or conditions or uses not described in this catalog.
- Nuclear energy control systems, combustion systems, railroad systems, aviation systems, medical equipment, amusement machines, vehicles, safety equipment, and installations subject to separate industry or government regulations.
- Systems, machines, and equipment that could present a risk to life or property.

Please know and observe all prohibitions of use applicable to the products.

NEVER USE THE PRODUCTS FOR AN APPLICATION INVOLVING SERIOUS RISK TO LIFE OR PROPERTY WITHOUT ENSURING THAT THE SYSTEM AS A WHOLE HAS BEEN DESIGNED TO ADDRESS THE RISKS, AND THAT THE OMRON PRODUCTS ARE PROPERLY RATED AND INSTALLED FOR THE INTENDED USE WITHIN THE OVERALL EQUIPMENT OR SYSTEM.

PROGRAMMABLE PRODUCTS

OMRON shall not be responsible for the user's programming of a programmable product, or any consequence thereof.

Disclaimers

CHANGE IN SPECIFICATIONS

Product specifications and accessories may be changed at any time based on improvements and other reasons.

It is our practice to change model numbers when published ratings or features are changed, or when significant construction changes are made. However, some specifications of the products may be changed without any notice. When in doubt, special model numbers may be assigned to fix or establish key specifications for your application on your request. Please consult with your OMRON representative at any time to confirm actual specifications of purchased products.

DIMENSIONS AND WEIGHTS

Dimensions and weights are nominal and are not to be used for manufacturing purposes, even when tolerances are shown.

PERFORMANCE DATA

Performance data given in this catalog is provided as a guide for the user in determining suitability and does not constitute a warranty. It may represent the result of OMRON's test conditions, and the users must correlate it to actual application requirements. Actual performance is subject to the OMRON Warranty and Limitations of Liability.

ERRORS AND OMISSIONS

The information in this document has been carefully checked and is believed to be accurate; however, no responsibility is assumed for clerical, typographical, or proofreading errors, or omissions.

2008.11

In the interest of product improvement, specifications are subject to change without notice.

OMRON Corporation
Industrial Automation Company

<http://www.ia.omron.com/>

(c)Copyright OMRON Corporation 2008 All Right Reserved.

Компания «Океан Электроники» предлагает заключение долгосрочных отношений при поставках импортных электронных компонентов на взаимовыгодных условиях!

Наши преимущества:

- Поставка оригинальных импортных электронных компонентов напрямую с производств Америки, Европы и Азии, а так же с крупнейших складов мира;
- Широкая линейка поставок активных и пассивных импортных электронных компонентов (более 30 млн. наименований);
- Поставка сложных, дефицитных, либо снятых с производства позиций;
- Оперативные сроки поставки под заказ (от 5 рабочих дней);
- Экспресс доставка в любую точку России;
- Помощь Конструкторского Отдела и консультации квалифицированных инженеров;
- Техническая поддержка проекта, помощь в подборе аналогов, поставка прототипов;
- Поставка электронных компонентов под контролем ВП;
- Система менеджмента качества сертифицирована по Международному стандарту ISO 9001;
- При необходимости вся продукция военного и аэрокосмического назначения проходит испытания и сертификацию в лаборатории (по согласованию с заказчиком);
- Поставка специализированных компонентов военного и аэрокосмического уровня качества (Xilinx, Altera, Analog Devices, Intersil, Interpoint, Microsemi, Actel, Aeroflex, Peregrine, VPT, Syfer, Eurofarad, Texas Instruments, MS Kennedy, Miteq, Cobham, E2V, MA-COM, Hittite, Mini-Circuits, General Dynamics и др.);

Компания «Океан Электроники» является официальным дистрибьютором и эксклюзивным представителем в России одного из крупнейших производителей разъемов военного и аэрокосмического назначения «JONHON», а так же официальным дистрибьютором и эксклюзивным представителем в России производителя высокотехнологичных и надежных решений для передачи СВЧ сигналов «FORSTAR».



JONHON

«JONHON» (основан в 1970 г.)

Разъемы специального, военного и аэрокосмического назначения:

(Применяются в военной, авиационной, аэрокосмической, морской, железнодорожной, горно- и нефтедобывающей отраслях промышленности)

«FORSTAR» (основан в 1998 г.)

ВЧ соединители, коаксиальные кабели, кабельные сборки и микроволновые компоненты:

(Применяются в телекоммуникациях гражданского и специального назначения, в средствах связи, РЛС, а так же военной, авиационной и аэрокосмической отраслях промышленности).



Телефон: 8 (812) 309-75-97 (многоканальный)

Факс: 8 (812) 320-03-32

Электронная почта: ocean@oceanchips.ru

Web: <http://oceanchips.ru/>

Адрес: 198099, г. Санкт-Петербург, ул. Калинина, д. 2, корп. 4, лит. А