

## SMD PTC Thermistors For Overload Protection

**RoHS**  
COMPLIANT

### FEATURES

- Ideal for pick-and-place circuit assembly
- Low mounting height
- Suitable for reflow soldering
- Small ceramic diameter for faster response
- Low heat transfer to substrate
- Flat terminations for stable positioning and good solderability
- Compliant to RoHS directive 2002/95/EC and in accordance to WEEE 2002/96/EC

### APPLICATIONS

Over-temperature/over-load protection:

- Telecom
  - Central office switching (C.O.)
  - Subscriber terminal equipment (T.E.)
  - Set top box
  - Modems
  - Cable TV communications
- General industry and automotive
  - Low power supplies overload protection
  - Data bus protection

### DESCRIPTION

The component consists of a high-performance PTC ceramic disc mounted in a lead-frame for direct soldering onto a printed-circuit board (PCB) or substrate.

The ceramic is soldered to the leadframe by a local reflow process, during which the solder layer is melted to the metallized ceramic surface using a low residue flux.

### MARKING

- All SMD PTCs are marked with the last 3-digits of the type number (XXX) and a date code (YYWW)

QUICK REFERENCE DATA		
DESCRIPTION	VALUE	
	STANDARD TYPES (1) (2)	TELECOM TYPES (1) (2)
Nominal R25	2 Ω to 500 Ω	10 Ω to 70 Ω
Resistance tolerance	± 10 %; ± 15 %; ± 20 %	
Maximum overload current (voltage dependent)	2 A to 10 A	
Non-trip current	50 mA to 500 mA at 25 °C	50 mA to 100 mA at 70 °C
Maximum voltage	16 V <sub>RMS</sub> to 400 V <sub>RMS</sub>	220 V <sub>RMS</sub> to 600 V <sub>RMS</sub>
Response time at 25 °C and 20 W overload power	< 1 s	
Matching	-	Down to 0.5 Ω
Maximum continuous power at 25 °C	2 W	

#### Notes

- (1) Customized products are available on request  
 (2) Coated and/or reinforced types are available on request

ELECTRICAL DATA AND ORDERING INFORMATION											
RESISTANCE		MATCHING Ω	V MAX. (V)	I <sub>nt</sub> at		I <sub>t</sub> at 25 °C (mA)	MAX. TRIP-TIME at 1 A (s)	I <sub>max.</sub> at V <sub>max.</sub> (A)	CATALOG NUMBER		
R <sub>25</sub> (Ω)	TOL (%)			25 °C (mA)	70 °C (mA)				12NC	SAP CODING	
<b>Telecommunication Types</b>											
10	20	no	245	165	100	270	3.0	2.0	2381 661 97012 <sup>(3)</sup>	PTCTZ3NR100GTE <sup>(3)</sup>	
10	20	0.5	245	165	100	270	3.0	2.0	2381 661 97016 <sup>(3)</sup>	PTCTZ3MR100GTE <sup>(3)</sup>	
40	25	no	265	80	50	130	0.8	2.0	2381 661 97002	PTCTZ3NR400HTE	
25	20	1	265	120	70	220	1.3	2.0	2381 661 97005 <sup>(3)</sup>	PTCTZ3MR250HTE <sup>(3)</sup>	
15 to 20	-	no	300	150	100	250	1.5	1.5	2381 661 97004 <sup>(3)</sup>	PTCTZ3NR150KTE <sup>(3)</sup>	
15 to 20	-	0.5	300	150	100	250	1.5	2.0	2381 661 97003 <sup>(3)</sup>	PTCTZ3MR150KTE <sup>(3)</sup>	
20	20	0.5	300	120	70	250	1.4	1.5	2381 661 97018 <sup>(3)</sup>	PTCTZ3MR200KTE <sup>(3)</sup>	
35	+ 15/- 20	1	425	110	70	175	1.0	0.7	2381 661 97009 <sup>(3)</sup>	PTCTZ3MR350MTE <sup>(3)</sup>	
50	20	1	425	90	60	150	0.8	0.7	2381 661 97019	PTCTZ3MR500MTE	
<b>General Industrial Types</b>											
3.3	25	-	24	400	-	650	6.0	8.0	2381 661 97013 <sup>(3)</sup>	PTCTZ3NR339CTE <sup>(3)</sup>	
9.4	25	-	60	150	100	300	1.8	3.0	2381 661 97011 <sup>(3)</sup>	PTCTZ3NR949ETE <sup>(3)</sup>	

#### Note

(3) These types pass ITU-K20-21-45 edition 2003 telecommunication protection recommendation

**PTC OUTLINES**

PTC SMD ceramic size: 6.5 mm

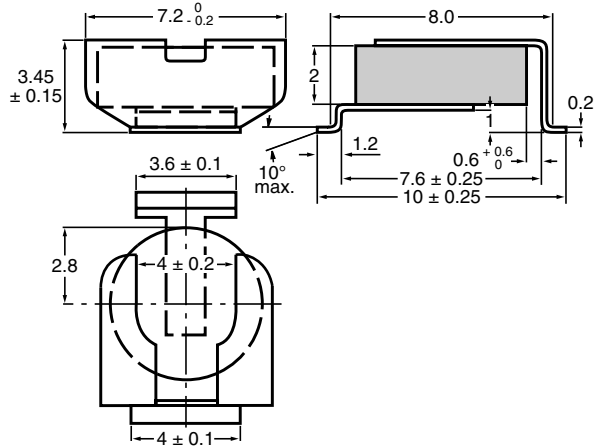
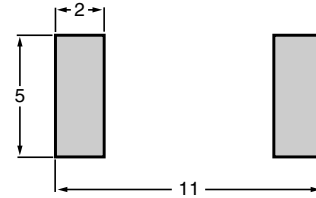

**DIMENSIONS OF SOLDER LANDS** in millimeters

**DIMENSIONS** in millimeters

MATERIAL INFORMATION		
REF.	DESCRIPTION	MATERIAL AND REMARKS
1	Ceramic	BaTiO <sub>3</sub> doped
2	Metallization	NiCr Ag layer (vacuum deposition)
3	Leadframe	Ni plated phosphor bronze material covered by PbSn8 solder layer

**SOLDERING CONDITIONS**

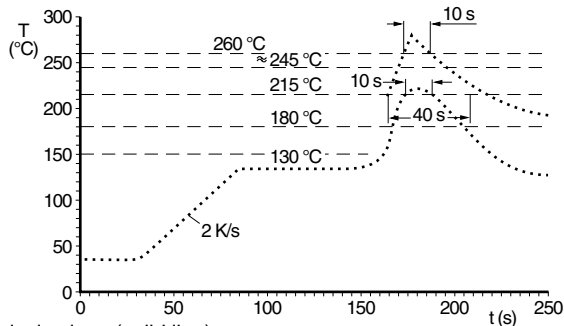
This SMD thermistor is only suitable for reflow soldering, in accordance with JEDEC J-STD-020D. Soldering processes which can be used are reflow (infrared and convection heating) and vapour phase. The maximum temperature of 260 °C during 10 s should not be exceeded and no liquid flux should be allowed to reach the ceramic body.

Typical examples of a soldering processes that will provide reliable joints without damage, are shown below.

**Reflow soldering**

Typical values (solid line)  
Process limits (dotted lines)

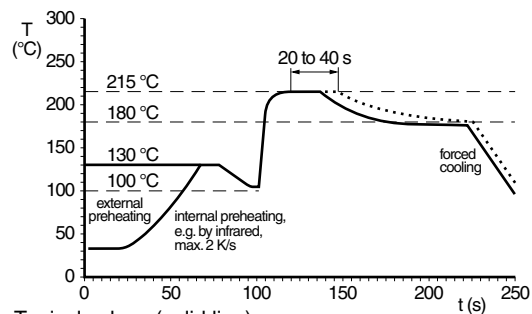
**Vapour phase soldering**

Typical values (solid line)  
Process limits (dotted lines)

**HANDLING PRECAUTIONS**

The special leadframe construction and the applied processes do not allow high handling forces on the component. Because of the nature of PTC ceramic material the component should not be touched with bare hands, as the residue of perspiration can influence component behaviour at high temperatures.

Handling forces vertically applied to the centre of the component should be limited to 5 N in the non-soldered condition and to 10 N in the soldered. These forces should not be exceeded during the handling, transportation and packaging of the soldered product.

For those applications where higher handling forces can be present, a reinforced version is available on request.



## Disclaimer

ALL PRODUCT, PRODUCT SPECIFICATIONS AND DATA ARE SUBJECT TO CHANGE WITHOUT NOTICE TO IMPROVE RELIABILITY, FUNCTION OR DESIGN OR OTHERWISE.

Vishay Intertechnology, Inc., its affiliates, agents, and employees, and all persons acting on its or their behalf (collectively, "Vishay"), disclaim any and all liability for any errors, inaccuracies or incompleteness contained in any datasheet or in any other disclosure relating to any product.

Vishay makes no warranty, representation or guarantee regarding the suitability of the products for any particular purpose or the continuing production of any product. To the maximum extent permitted by applicable law, Vishay disclaims (i) any and all liability arising out of the application or use of any product, (ii) any and all liability, including without limitation special, consequential or incidental damages, and (iii) any and all implied warranties, including warranties of fitness for particular purpose, non-infringement and merchantability.

Statements regarding the suitability of products for certain types of applications are based on Vishay's knowledge of typical requirements that are often placed on Vishay products in generic applications. Such statements are not binding statements about the suitability of products for a particular application. It is the customer's responsibility to validate that a particular product with the properties described in the product specification is suitable for use in a particular application. Parameters provided in datasheets and/or specifications may vary in different applications and performance may vary over time. All operating parameters, including typical parameters, must be validated for each customer application by the customer's technical experts. Product specifications do not expand or otherwise modify Vishay's terms and conditions of purchase, including but not limited to the warranty expressed therein.

Except as expressly indicated in writing, Vishay products are not designed for use in medical, life-saving, or life-sustaining applications or for any other application in which the failure of the Vishay product could result in personal injury or death. Customers using or selling Vishay products not expressly indicated for use in such applications do so at their own risk. Please contact authorized Vishay personnel to obtain written terms and conditions regarding products designed for such applications.

No license, express or implied, by estoppel or otherwise, to any intellectual property rights is granted by this document or by any conduct of Vishay. Product names and markings noted herein may be trademarks of their respective owners.

## Material Category Policy

**Vishay Intertechnology, Inc. hereby certifies that all its products that are identified as RoHS-Compliant fulfill the definitions and restrictions defined under Directive 2011/65/EU of The European Parliament and of the Council of June 8, 2011 on the restriction of the use of certain hazardous substances in electrical and electronic equipment (EEE) - recast, unless otherwise specified as non-compliant.**

**Please note that some Vishay documentation may still make reference to RoHS Directive 2002/95/EC. We confirm that all the products identified as being compliant to Directive 2002/95/EC conform to Directive 2011/65/EU.**

**Vishay Intertechnology, Inc. hereby certifies that all its products that are identified as Halogen-Free follow Halogen-Free requirements as per JEDEC JS709A standards. Please note that some Vishay documentation may still make reference to the IEC 61249-2-21 definition. We confirm that all the products identified as being compliant to IEC 61249-2-21 conform to JEDEC JS709A standards.**

Компания «Океан Электроники» предлагает заключение долгосрочных отношений при поставках импортных электронных компонентов на взаимовыгодных условиях!

Наши преимущества:

- Поставка оригинальных импортных электронных компонентов напрямую с производств Америки, Европы и Азии, а так же с крупнейших складов мира;
- Широкая линейка поставок активных и пассивных импортных электронных компонентов (более 30 млн. наименований);
- Поставка сложных, дефицитных, либо снятых с производства позиций;
- Оперативные сроки поставки под заказ (от 5 рабочих дней);
- Экспресс доставка в любую точку России;
- Помощь Конструкторского Отдела и консультации квалифицированных инженеров;
- Техническая поддержка проекта, помощь в подборе аналогов, поставка прототипов;
- Поставка электронных компонентов под контролем ВП;
- Система менеджмента качества сертифицирована по Международному стандарту ISO 9001;
- При необходимости вся продукция военного и аэрокосмического назначения проходит испытания и сертификацию в лаборатории (по согласованию с заказчиком);
- Поставка специализированных компонентов военного и аэрокосмического уровня качества (Xilinx, Altera, Analog Devices, Intersil, Interpoint, Microsemi, Actel, Aeroflex, Peregrine, VPT, Syfer, Eurofarad, Texas Instruments, MS Kennedy, Miteq, Cobham, E2V, MA-COM, Hittite, Mini-Circuits, General Dynamics и др.);

Компания «Океан Электроники» является официальным дистрибьютором и эксклюзивным представителем в России одного из крупнейших производителей разъемов военного и аэрокосмического назначения «JONHON», а так же официальным дистрибьютором и эксклюзивным представителем в России производителя высокотехнологичных и надежных решений для передачи СВЧ сигналов «FORSTAR».



## JONHON

«JONHON» (основан в 1970 г.)

Разъемы специального, военного и аэрокосмического назначения:

(Применяются в военной, авиационной, аэрокосмической, морской, железнодорожной, горно- и нефтедобывающей отраслях промышленности)

«FORSTAR» (основан в 1998 г.)

ВЧ соединители, коаксиальные кабели, кабельные сборки и микроволновые компоненты:

(Применяются в телекоммуникациях гражданского и специального назначения, в средствах связи, РЛС, а так же военной, авиационной и аэрокосмической отраслях промышленности).



Телефон: 8 (812) 309-75-97 (многоканальный)

Факс: 8 (812) 320-03-32

Электронная почта: [ocean@oceanchips.ru](mailto:ocean@oceanchips.ru)

Web: <http://oceanchips.ru/>

Адрес: 198099, г. Санкт-Петербург, ул. Калинина, д. 2, корп. 4, лит. А