



SST38VF6401B / SST38VF6402B SST38VF6403B / SST38VF6404B

64 Mbit (x16) Advanced Multi-Purpose Flash Plus

Features

- Organized as 4M x16
- Single Voltage Read and Write Operations
 - 2.7-3.6V
- Superior Reliability
 - Endurance: 100,000 Cycles minimum
 - Greater than 100 years Data Retention
- Low Power Consumption (typical values at 5 MHz)
 - Active Current: 25 mA (typical)
 - Standby Current: 5 μ A (typical)
 - Auto Low Power Mode: 5 μ A (typical)
- 128-bit Unique ID
- Security-ID Feature
 - 248 Word, user One-Time-Programmable
- Protection and Security Features
 - Hardware Boot Block Protection/WP# Input Pin, Uniform (32 KWord), and Non-Uniform (8 KWord) options available
 - User-controlled individual block (32 KWord) protection, using software only methods
 - Password protection
- Hardware Reset Pin (RST#)
- Fast Read and Page Read Access Times:
 - 70 ns Read access time
 - 25 ns Page Read access times
 - 8-Word Page Read buffer
- Latched Address and Data
- Fast Erase Times:
 - Block-Erase Time: 18 ms (typical)
 - Chip-Erase Time: 40 ms (typical)
- Erase-Suspend/-Resume Capabilities
- Fast Word and Write-Buffer Programming Times:
 - Word-Program Time: 7 μ s (typical)
 - Write Buffer Programming Time: 1.75 μ s / Word (typical)
 - 16-Word Write Buffer
- Automatic Write Timing
 - Internal V_{PP} Generation
- End-of-Write Detection
 - Toggle Bits
 - Data# Polling
 - RY/BY# Output
- CMOS I/O Compatibility

- JEDEC Standard
 - Flash EEPROM Pinouts and command sets
- CFI Compliant
- Packages Available
 - 48-lead TSOP
 - 48-ball TFBGA
- All non-Pb (lead-free) devices are RoHS compliant

Description

The SST38VF6401B, SST38VF6402B, SST38VF6403B, and SST38VF6404B devices are 4M x16 CMOS Advanced Multi-Purpose Flash Plus (Advanced MPF+) manufactured with Microchip proprietary, high-performance CMOS SuperFlash technology. The split-gate cell design and thick-oxide tunneling injector attain better reliability and manufacturability compared with alternate approaches. The SST38VF6401B/6402B/6403B/6404B write (Program or Erase) with a 2.7-3.6V power supply. These devices conform to JEDEC standard pin assignments for x16 memories.

Featuring high performance Word-Program, the SST38VF6401B/6402B/6403B/6404B provide a typical Word-Program time of 7 μ sec. For faster word-programming performance, the Write-Buffer Programming feature, has a typical word-program time of 1.75 μ sec. These devices use Toggle Bit, Data# Polling, or the RY/BY# pin to indicate Program operation completion. In addition to single-word Read, Advanced MPF+ devices provide a Page-Read feature that enables a faster word read time of 25 ns, eight words on the same page.

To protect against inadvertent write, the SST38VF6401B/6402B/6403B/6404B have on-chip hardware and Software Data Protection schemes. Designed, manufactured, and tested for a wide spectrum of applications, these devices are available with 100,000 cycles minimum endurance. Data retention is rated at greater than 100 years.

The SST38VF6401B/6402B/6403B/6404B are suited for applications that require the convenient and economical updating of program, configuration, or data memory. For all system applications, Advanced MPF+ significantly improve performance and reliability, while lowering power consumption. These devices inherently use less energy during Erase and Program than alternative flash technologies. The total energy consumed is a function of the applied voltage, current, and time of application. For any given voltage range, the SuperFlash technology uses less current to program and has

a shorter erase time; therefore, the total energy consumed during any Erase or Program operation is less than alternative flash technologies.

These devices also improve flexibility while lowering the cost for program, data, and configuration storage applications. The SuperFlash technology provides fixed Erase and Program times, independent of the number of Erase/Program cycles that have occurred. Therefore, the system software or hardware does not have to be modified or de-rated as is necessary with alternative flash technologies, whose Erase and Program times increase with accumulated Erase/Program cycles.

The SST38VF6401B/6402B/6403B/6404B also offer flexible data protection features. Applications that require memory protection from program and erase operations can use the Boot Block, Individual Block Protection, and Advanced Protection features. For applications that require a permanent solution, the Irreversible Block Locking feature provides permanent protection for memory blocks.

To meet high-density, surface mount requirements, the SST38VF6401B/6402B/6403B/6404B devices are offered in 48-lead TSOP and 48-ball TFBGA packages. See Figures 2-1 and for pin assignments and Table 2-1 for pin descriptions.

TO OUR VALUED CUSTOMERS

It is our intention to provide our valued customers with the best documentation possible to ensure successful use of your Microchip products. To this end, we will continue to improve our publications to better suit your needs. Our publications will be refined and enhanced as new volumes and updates are introduced.

If you have any questions or comments regarding this publication, please contact the Marketing Communications Department via E-mail at docerrors@microchip.com. We welcome your feedback.

Most Current Data Sheet

To obtain the most up-to-date version of this data sheet, please register at our Worldwide Web site at:

<http://www.microchip.com>

You can determine the version of a data sheet by examining its literature number found on the bottom outside corner of any page. The last character of the literature number is the version number, (e.g., DS30000000A is version A of document DS30000000).

Errata

An errata sheet, describing minor operational differences from the data sheet and recommended workarounds, may exist for current devices. As device/documentation issues become known to us, we will publish an errata sheet. The errata will specify the revision of silicon and revision of document to which it applies.

To determine if an errata sheet exists for a particular device, please check with one of the following:

- Microchip's Worldwide Web site; <http://www.microchip.com>
- Your local Microchip sales office (see last page)

When contacting a sales office, please specify which device, revision of silicon and data sheet (include literature number) you are using.

Customer Notification System

Register on our web site at www.microchip.com to receive the most current information on all of our products.

1.0 FUNCTIONAL BLOCK DIAGRAM

FIGURE 1-1: FUNCTIONAL BLOCK DIAGRAM

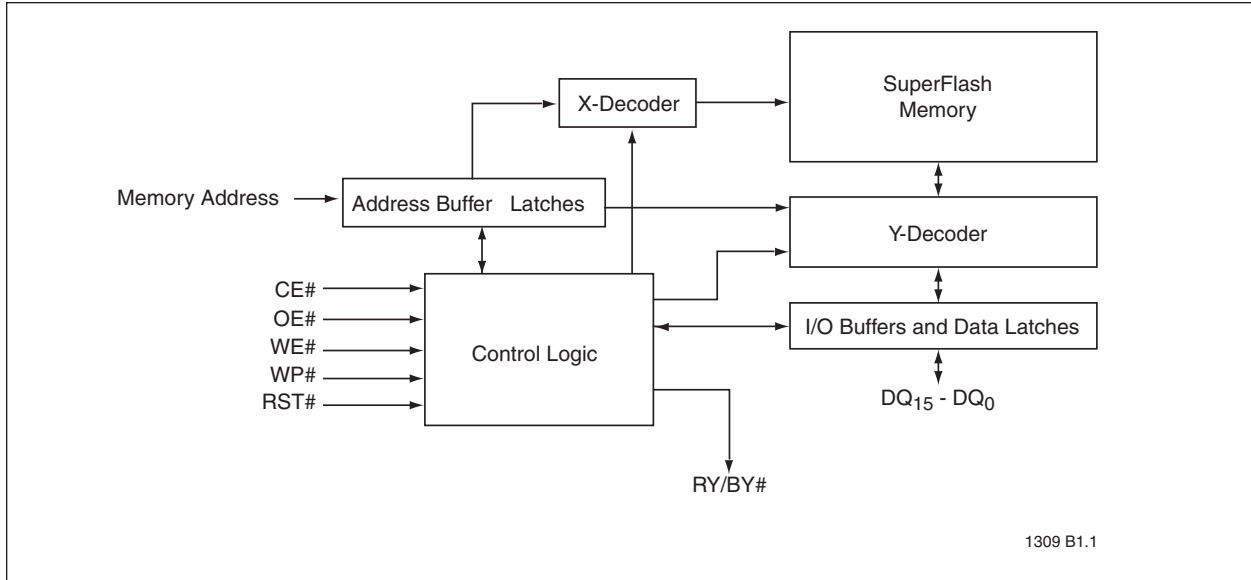

2.0 PIN ASSIGNMENTS

FIGURE 2-1: PIN ASSIGNMENTS FOR 48-LEAD TSOP

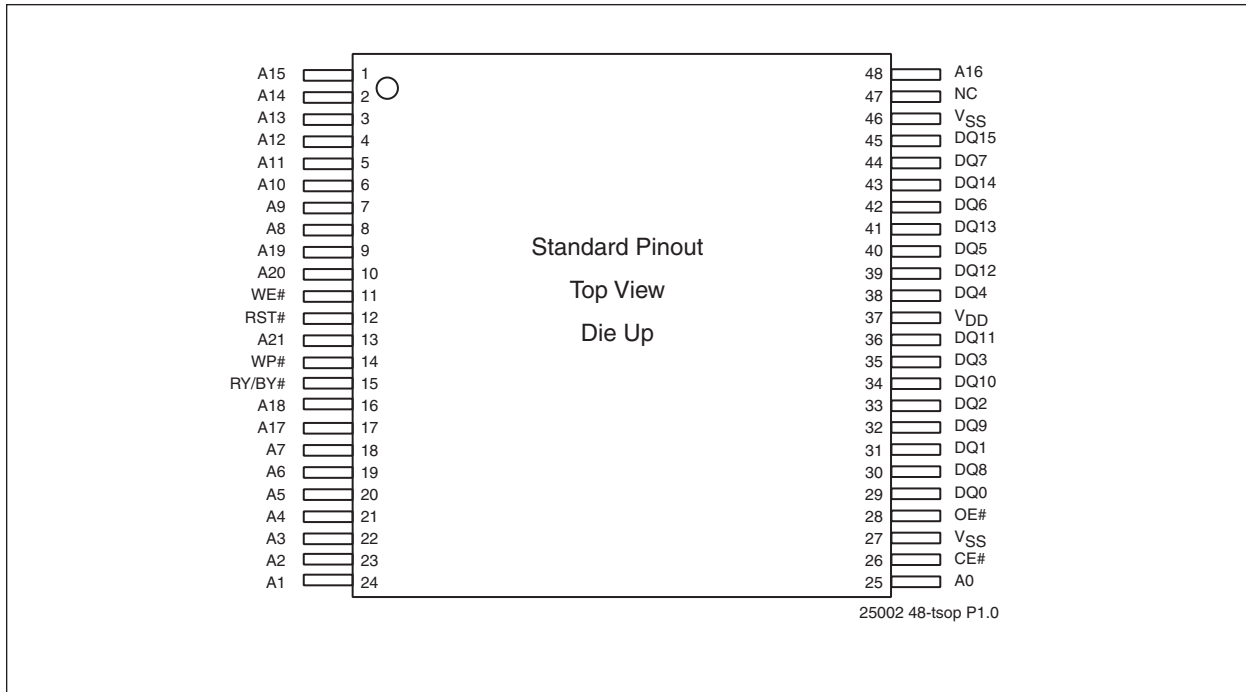

FIGURE 2-2: PIN ASSIGNMENTS FOR 48-BALL TFBGA

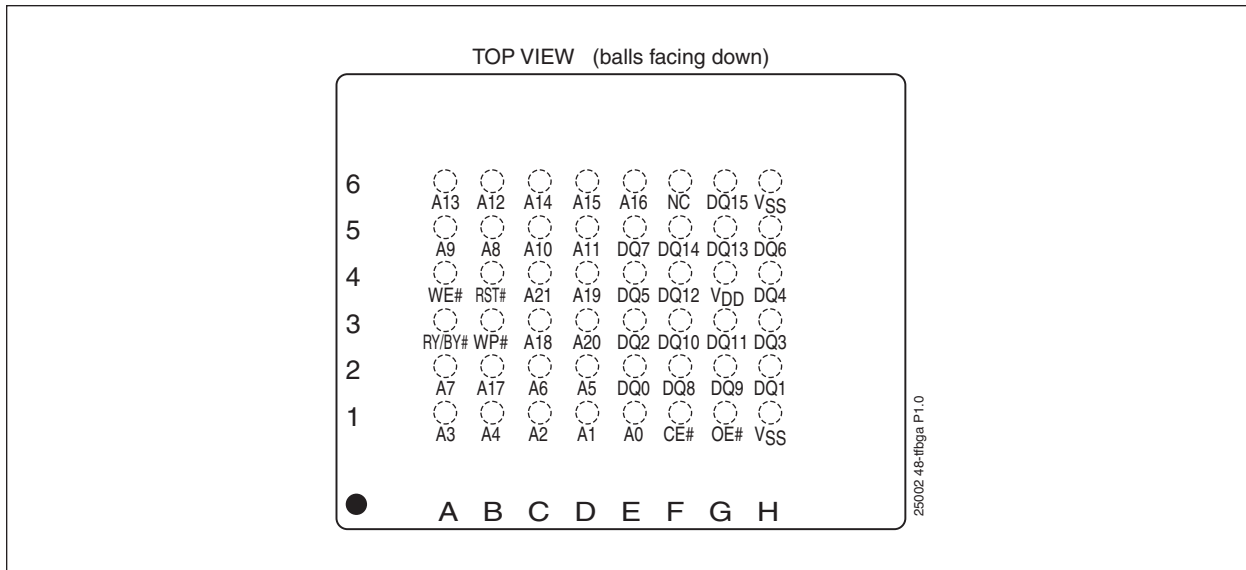

TABLE 2-1: PIN DESCRIPTION

Symbol	Pin Name	Functions
$A_{MS}^1-A_0$	Address Inputs	To provide memory addresses. During Block-Erase $A_{MS}-A_{15}$ address lines will select the block.
$DQ_{15}-DQ_0$	Data Input/output	To output data during Read cycles and receive input data during Write cycles. Data is internally latched during a Write cycle. The outputs are in tri-state when OE# or CE# is high.
WP#	Write Protect	To protect the top/bottom boot block from Erase/Program operation when grounded.
RY/BY#	Ready/Busy	To indicate when the device is actively programming or erasing.
RST#	Reset	To reset and return the device to Read mode.
CE#	Chip Enable	To activate the device when CE# is low.
OE#	Output Enable	To gate the data output buffers.
WE#	Write Enable	To control the Write operations.
V_{DD}	Power Supply	To provide power supply voltage: 2.7-3.6V
V_{SS}	Ground	
NC	No Connection	Unconnected pins.

1. A_{MS} = Most significant address
 $A_{MS} = A_{21}$ for SST38VF6401B/6402B/6403B/6404B

3.0 MEMORY MAPS

TABLE 3-1: SST38VF6401B AND SST38VF6402B MEMORY MAPS

SST38VF6401B					
Block¹	Size	Address A₂₁-A₁₅²	VPB³	NVPB³	WP#⁴
B0 ⁴	32 KWord	0000000	YES	YES	YES
B1	32 KWord	0000001	YES	YES	NO
B2	32 KWord	0000010	YES	YES	NO
B3	32 KWord	0000011	YES	YES	NO
B4	32 KWord	0000100	YES	YES	NO
B5	32 KWord	0000101	YES	YES	NO
B6	32 KWord	0000110	YES	YES	NO
B7	32 KWord	0000111	YES	YES	NO
B8 - B119 follow the same pattern					
B120	32 KWord	1111000	YES	YES	NO
B121	32 KWord	1111001	YES	YES	NO
B122	32 KWord	1111010	YES	YES	NO
B123	32 KWord	1111011	YES	YES	NO
B124	32 KWord	1111100	YES	YES	NO
B125	32 KWord	1111101	YES	YES	NO
B126	32 KWord	1111110	YES	YES	NO
B127	32 KWord	1111111	YES	YES	NO
SST38VF6402B					
Block¹	Size	Address A₂₁-A₁₅²	VPB³	NVPB³	WP#⁵
B0	32 KWord	0000000	YES	YES	NO
B1	32 KWord	0000001	YES	YES	NO
B2	32 KWord	0000010	YES	YES	NO
B3	32 KWord	0000011	YES	YES	NO
B4	32 KWord	0000100	YES	YES	NO
B5	32 KWord	0000101	YES	YES	NO
B6	32 KWord	0000110	YES	YES	NO
B7	32 KWord	0000111	YES	YES	NO
B8 - B119 follow the same pattern					
B120	32 KWord	1111000	YES	YES	NO
B121	32 KWord	1111001	YES	YES	NO
B122	32 KWord	1111010	YES	YES	NO
B123	32 KWord	1111011	YES	YES	NO
B124	32 KWord	1111100	YES	YES	NO
B125	32 KWord	1111101	YES	YES	NO
B126	32 KWord	1111110	YES	YES	NO
B127 ⁵	32 KWord	1111111	YES	YES	YES

1. Each block, B0-B127 is 32KWord.
2. X = 0 or 1. Block Address (BA) = A₂₁ - A₁₅
3. Each block has an associated VPB and NVPB.
4. Block B0 is the boot block.
5. Block B127 is the boot block.

SST38VF6401B / SST38VF6402B / SST38VF6403B / SST38VF6404B

TABLE 3-2: SST38VF6403B AND SST38VF6404B MEMORY MAPS (SHEET 1 OF 2)

SST38VF6403B					
Block¹	Size	Address A₂₁-A₁₅²	VPB³	NVPB³	WP#⁴
B0 ^{3,4}	4 KWord	000000000	YES	YES	YES
B1	4 KWord	000000001	YES	YES	YES
B2	4 KWord	000000010	YES	YES	NO
B3	4 KWord	000000011	YES	YES	NO
B4	4 KWord	000000100	YES	YES	NO
B5	4 KWord	000000101	YES	YES	NO
B6	4 KWord	000000110	YES	YES	NO
B7	4 KWord	000000111	YES	YES	NO
B8	32 KWord	000001XXX	YES	YES	NO
B9	32 KWord	0000010XXX	YES	YES	NO
B10	32 KWord	0000011XXX	YES	YES	NO
B11	32 KWord	0000100XXX	YES	YES	NO
B12	32 KWord	0000101XXX	YES	YES	NO
B13	32 KWord	0000110XXX	YES	YES	NO
B14	32 KWord	0000111XXX	YES	YES	NO
B15	32 KWord	0001000XXX	YES	YES	NO
B16 - B126 follow the same pattern					
B127	32 KWord	1111000XXX	YES	YES	NO
B128	32 KWord	1111001XXX	YES	YES	NO
B129	32 KWord	1111010XXX	YES	YES	NO
B1230	32 KWord	1111011XXX	YES	YES	NO
B1231	32 KWord	1111100XXX	YES	YES	NO
B1232	32 KWord	1111101XXX	YES	YES	NO
B133	32 KWord	1111110XXX	YES	YES	NO
B134	32 KWord	1111111XXX	YES	YES	NO
SST38VF6404B					
Block¹	Size	Address A₂₁-A₁₅²	VPB³	NVPB³	WP#⁵
B0	32 KWord	0000000XXX	YES	YES	NO
B1	32 KWord	0000001XXX	YES	YES	NO
B2	32 KWord	0000010XXX	YES	YES	NO
B3	32 KWord	0000011XXX	YES	YES	NO
B4	32 KWord	0000100XXX	YES	YES	NO
B5	32 KWord	0000101XXX	YES	YES	NO
B6	32 KWord	0000110XXX	YES	YES	NO
B7	32 KWord	0000111XXX	YES	YES	NO
B8 - B119 follow the same pattern					
B120	32 KWord	1111000XXX	YES	YES	NO
B121	32 KWord	1111001XXX	YES	YES	NO
B122	32 KWord	1111010XXX	YES	YES	NO
B123	32 KWord	1111011XXX	YES	YES	NO
B124	32 KWord	1111100XXX	YES	YES	NO
B125	32 KWord	1111101XXX	YES	YES	NO
B126	32 KWord	1111110XXX	YES	YES	NO
B127 ^{3, 5}	4 KWord	1111111000	YES	YES	NO

SST38VF6401B / SST38VF6402B / SST38VF6403B / SST38VF6404B

TABLE 3-2: SST38VF6403B AND SST38VF6404B MEMORY MAPS (CONTINUED) (SHEET 2 OF 2)

B128	4 KWord	1111111001	YES	YES	NO
B129	4 KWord	1111111010	YES	YES	NO
B130	4 KWord	1111111011	YES	YES	NO
B131	4 KWord	1111111100	YES	YES	NO
B132	4 KWord	1111111101	YES	YES	NO
B133	4 KWord	1111111110	YES	YES	YES
B134	4 KWord	1111111111	YES	YES	YES

1. Each block, B0-B127 is 32KWord.
2. $X = 0$ or 1 . Block Address (BA) = $A_{21} - A_{15}$
3. Each block has an associated VPB and NVPB, except for some blocks in SST38VF6403B and SST38VF6404B.
In SST38VF6403B, Block B0 does not have a single VPB or NVPB for all 32 KWords. Instead, each block (4 KWord) in Block B0 has its own VPB and NVPB.
In SST38VF6404B, Block B127 does not have a single VPB or NVPB for all 32 KWords. Instead, each block (4 KWord) in Block B127 has its own VPB and NVPB.
4. The 8KWord boot block consists of S0 and S1 in Block B0.
5. The 8KWord boot block consists of S1022 and S1023 in Block B127.

4.0 DEVICE OPERATION

The memory operations functions of these devices are initiated using commands written to the device using standard microprocessor Write sequences. A command is written by asserting WE# low while keeping CE# low. The address bus is latched on the falling edge of WE# or CE#, whichever occurs last. The data bus is latched on the rising edge of WE# or CE#, whichever occurs first.

The SST38VF6401B/6402B/6403B/6404B also have the Auto Low Power mode which puts the device in a near-standby mode after data has been accessed with a valid Read operation. This reduces the I_{DD} active read current from typically 6 mA to typically 5 μ A. The device requires no access time to exit the Auto Low Power mode after any address transition or control signal transition used to initiate another Read cycle. The device does not enter Auto-Low Power mode after power-up with CE# held steadily low, until the first address transition or CE# is driven high.

4.1 Read

The Read operation of the SST38VF6401B/6402B/6403B/6404B is controlled by CE# and OE#, both of which have to be low for the system to obtain data from the outputs. CE# is used for device selection. When CE# is high, the chip is deselected and only standby power is consumed. OE# is the output control and is used to gate data from the output pins. The data bus is in high impedance state when either CE# or OE# is high. Refer to Figure 6-1, the Read cycle timing diagram, for further details.

4.2 Page Read

The Page Read operation utilizes an asynchronous method that enables the system to read data from the SST38VF6401B/6402B/6403B/6404B at a faster rate. This operation allows users to read an eight-word page of data at an average speed of 33 ns per word.

In Page Read, the initial word read from the page requires T_{ACC} to be valid, while the remaining seven words in the page require only T_{PACC} . All eight words in the page have the same address bits, $A_{21}-A_3$, which are used to select the page. Address bits A_2-A_0 are toggled, in any order, to read the words within the page.

The Page Read operation of the SST38VF6401B/6402B/6403B/6404B is controlled by CE# and OE#. Both CE# and OE# must be low for the system to obtain data from the output pins. CE# controls device selection. When CE# is high, the chip is deselected and only standby power is consumed. OE# is the output control and is used to gate data from the output pins. The data bus is in high impedance state when either CE# or OE# is high. Refer to Figure 6-3, the Page Read cycle timing diagram, for further details.

4.3 Word-Program Operation

The SST38VF6401B/6402B/6403B/6404B can be programmed on a word-by-word basis. Before programming, the block where the word exists must be fully erased. The Program operation is accomplished in three steps. The first step is the three-byte load sequence for Software Data Protection. The second step is to load word address and word data. During the Word-Program operation, the addresses are latched on the falling edge of either CE# or WE#, whichever occurs last. The data is latched on the rising edge of either CE# or WE#, whichever occurs first. The third step is the internal Program operation which is initiated after the rising edge of the fourth WE# or CE#, whichever occurs first. The Program operation, once initiated, will be completed within 7 μ s. See Figures 6-3 and 6-4 for WE# and CE# controlled Program operation timing diagrams and Figure 6-19 for flowcharts.

During the Program operation, the only valid reads are Data# Polling, Toggle Bits, and RY/BY#. During the internal Program operation, the host is free to perform additional tasks. Any commands issued during the internal Program operation are ignored. During the command sequence, WP# should be statically held high or low.

When programming more than a few words, Microchip recommends Write-Buffer Programming.

4.4 Write-Buffer Programming

The SST38VF6401B/6402B/6403B/6404B offer Write-Buffer Programming, a feature that enables faster effective word programming. To use this feature, write up to 16 words with the Write-to-Buffer command, then use the Program Buffer-to-Flash command to program the Write-Buffer to memory.

The Write-to-Buffer command consists of between 5 and 20 write cycles. The total number of write cycles in the Write-to-Buffer command sequence is equal to the number of words to be written to the buffer plus four.

The first three cycles in the command sequence tell the device that a Write-to-Buffer operation will begin.

The fourth cycle tells the device the number of words to be written into the buffer and the block address of these words. Specifically, the write cycle consists of a block address and a data value called the Word Count (WC), which is the number of words to be written to the buffer minus one. If the WC is greater than 15, the maximum buffer size minus 1, then the operation aborts.

For the fifth cycle, and all subsequent cycles of the Write-to-Buffer command, the command sequence consists of the addresses and data of the words to be written into the buffer. All of these cycles must have the same $A_{21}-A_4$ address, otherwise the operation aborts. The number of Write cycles required is equal to the number of words to be written into the Write-Buffer, which is equal to WC plus one. The correct number of

Write cycles must be issued or the operation will abort. Each Write cycle decrements the Write-Buffer counter, even if two or more of the Write cycles have identical address values. Only the final data loaded for each buffer location is held in the Write-Buffer.

Once the Write-to-Buffer command sequence is completed, the Program Buffer-to-Flash command should be issued to program the Write-Buffer contents to the specified block in memory. The block address (i.e. $A_{21} - A_{15}$) in this command must match the block address in the 4th write cycle of the Write-to-Buffer command or the operation aborts. See [Table 5-2](#) for details on Write-to-Buffer and Program-Buffer-to-Flash commands.

While issuing these command sequences, the Write-Buffer Programming Abort detection bit (DQ₁) indicates if the operation has aborted. There are several cases in which the device can abort:

- In the fourth write cycle of the Write-to-Buffer command, if the WC is greater than 15, the operation aborts.
- In the fifth and all subsequent cycles of the Write-to-Buffer command, if the address values, $A_{21} - A_4$, are not identical, the operation aborts.
- If the number of write cycles between the fifth to the last cycle of the Write-to-Buffer command is greater than WC + 1, the operation aborts.
- After completing the Write-to-Buffer command sequence, issuing any command other than the Program Buffer-to-Flash command, aborts the operation.
- Loading a block address, i.e. $A_{21} - A_{15}$, in the Program Buffer-to-Flash command that does not match the block address used in the Write-to-Buffer command aborts the operation.

If the Write-to-Buffer or Program Buffer-to-Flash operation aborts, then DQ₁ = 1 and the device enters Write-Buffer-Abort mode. To execute another operation, a Write-to-Buffer Abort-Reset command must be issued to clear DQ₁ and return the device to standard read mode.

After the Write-to-Buffer and Program Buffer-to-Flash commands are successfully issued, the programming operation can be monitored using Data# Polling, Toggle Bits, and RY/BY#.

4.5 Block-Erase Operations

The Block-Erase operation allows the system to erase the device on a block-by-block basis.

The Block-Erase architecture is based on block size of 32 KWords. In SST38VF6401B and SST38VF6402B devices, the Block-Erase command can erase any 32KWord Block (B0-B127). For the non-uniform boot block devices, SST38VF6403B and SST38VF6404B, the Block-Erase command can erase any 32 KWord

block except the block that contains the boot area. In the boot area, Block-Erase only erases a 4KWord block.

The Block-Erase operation is initiated by executing a six-byte command sequence with Block-Erase command (30H) and block address (BA) in the last bus cycle. The block address is latched on the falling edge of the sixth WE# pulse, while the command (30H) is latched on the rising edge of the sixth WE# pulse. The internal Erase operation begins after the sixth WE# pulse. The End-of-Erase operation can be determined using either Data# Polling or Toggle Bit methods. The RY/BY# pin can also be used to monitor the erase operation. For more information, see [Figure 6-10](#) for timing waveforms and [Figure 6-24](#) for the flowchart.

Any commands, other than Erase-Suspend, issued during the Block-Erase operation are ignored. Any attempt to Block-Erase memory inside a block protected by Volatile Block Protection, Non-Volatile Block Protection, or WP# (low) will be ignored. During the command sequence, WP# should be statically held high or low.

4.6 Erase-Suspend/Erase-Resume Commands

The Erase-Suspend operation temporarily suspends a Block-Erase operation thus allowing data to be read or programmed into any block that is not engaged in an Erase operation. The operation is executed with a one-byte command sequence with Erase-Suspend command (BOH). The device automatically enters read mode within 20 μ s (max) after the Erase-Suspend command had been issued. Valid data can be read, using a Read or Page Read operation, from any block that is not being erased. Reading at an address location within Erase-Suspended blocks will output DQ₂ toggling and DQ₆ at '1'. While in Erase-Suspend, a Word-Program or Write-Buffer Programming operation is allowed anywhere except the block selected for Erase-Suspend.

To resume a suspended Block-Erase operation, the system must issue the Erase-Resume command. The operation is executed by issuing one byte command sequence with Erase-Resume command (30H) at any address in the last Byte sequence.

When an erase operation is suspended, or re-suspended, after resume the cumulative time needed for the erase operation to complete is greater than the erase time of a non-suspended erase operation. If the hold time from Erase-Resume to the next Erase-Suspend operation is less than 200 μ s, the accumulative erase time can become very long. Therefore, after issuing an Erase-Resume command, the system must wait at least 200 μ s before issuing another Erase-Suspend command. The Erase-Resume command will be ignored until any program operations initiated during Erase-Suspend are complete.

Bypass mode can be entered while in Erase-Suspend, but only Bypass Word-Program is available for those blocks that are not suspended. Bypass Block-Erase, Bypass Chip-Erase, Erase-Suspend, and Erase-Resume are not available. In order to resume an Erase operation, the Bypass mode must be exited before issuing Erase-Resume. For more information about Bypass mode, see “Bypass Mode” on page 14.

4.7 Chip-Erase Operation

The SST38VF6401B/6402B/6403B/6404B devices provide a Chip-Erase operation, which erases the entire memory array to the ‘1’ state. This operation is useful when the entire device must be quickly erased.

The Chip-Erase operation is initiated by executing a six-byte command sequence with Chip-Erase command (10H) at address 555H in the last byte sequence. The Erase operation begins with the rising edge of the sixth WE# or CE#, whichever occurs first. During the Erase operation, the only valid reads are Toggle Bit, Data# Polling, or RY/BY#. See Table 5-2 for the command sequence, Figure 6-9 for timing diagram, and Figure 6-24 for the flowchart. Any commands issued during the Chip-Erase operation are ignored. If WP# is low, or any VPBs or NVPBs are in the protect state, any attempt to execute a Chip-Erase operation is ignored. During the command sequence, WP# should be statically held high or low.

4.8 Write Operation Status Detection

To optimize the system Write cycle time, the SST38VF6401B/6402B/6403B/6404B provide two software means to detect the completion of a Write (Program or Erase) cycle. The software detection includes two status bits: Data# Polling (DQ₇) and Toggle Bit (DQ₆). The End-of-Write detection mode is enabled after the rising edge of WE#, which initiates the internal Program or Erase operation.

The actual completion of the nonvolatile write is asynchronous with the system. Therefore, Data# Polling or Toggle Bit maybe be read concurrent with the completion of the write cycle. If this occurs, the system may possibly get an incorrect result from the status detection process. For example, valid data may appear to conflict with either DQ₇ or DQ₆. To prevent false results, upon detection of failures, the software routine should loop to read the accessed location an additional two times. If both reads are valid, then the device has completed the Write cycle, otherwise the failure is valid.

For the Write-Buffer Programming feature, DQ₁ informs the user if either the Write-to-Buffer or Program Buffer-to-Flash operation aborts. If either operation aborts, then DQ₁ = 1. DQ₁ must be cleared to ‘0’ by issuing the Write-to-Buffer Abort Reset command.

The SST38VF6401B/6402B/6403B/6404B also provide a RY/BY# signal. This signal indicates the status of a Program or Erase operation.

If a Program or Erase operation is attempted on a protected block, the operation will abort. After the device initiates an abort, the corresponding Write Operation Status Detection Bits will stay active for approximately 200ns (program or erase) before the device returns to read mode.

For the status of these bits during a Write operation, see Table 4-1.

4.8.1 DATA# POLLING (DQ₇)

When the SST38VF6401B/6402B/6403B/6404B are in an internal Program operation, any attempt to read DQ₇ will produce the complement of true data. For a Program Buffer-to-Flash operation, DQ₇ is the complement of the last word loaded in the Write-Buffer using the Write-to-Buffer command. Once the Program operation is completed, DQ₇ will produce valid data. Note that even though DQ₇ may have valid data immediately following the completion of an internal Write operation, the remaining data outputs may still be invalid. Valid data on the entire data bus will appear in subsequent successive Read cycles after an interval of 1 μs.

During an internal Erase operation, any attempt to read DQ₇ will produce a ‘0’. Once the internal Erase operation is completed, DQ₇ will produce a ‘1’. The Data# Polling is valid after the rising edge of fourth WE# (or CE#) pulse for Program operation. For Block- or Chip-Erase, the Data# Polling is valid after the rising edge of sixth WE# (or CE#) pulse. See Figure 6-7 for Data# Polling timing diagram and Figure 6-21 for a flowchart.

4.8.2 TOGGLE BITS (DQ₆ AND DQ₂)

During the internal Program or Erase operation, any consecutive attempts to read DQ₆ will produce alternating ‘1’s and ‘0’s, i.e., toggling between ‘1’ and ‘0’. When the internal Program or Erase operation is completed, the DQ₆ bit will stop toggling, and the device is then ready for the next operation. For Block- or Chip-Erase, the toggle bit (DQ₆) is valid after the rising edge of sixth WE# (or CE#) pulse. DQ₆ will be set to ‘1’ if a Read operation is attempted on an Erase-Suspended Block. If Program operation is initiated in a block not selected in Erase-Suspend mode, DQ₆ will toggle.

An additional Toggle Bit is available on DQ₂, which can be used in conjunction with DQ₆ to check whether a particular block is being actively erased or erase-suspended. Table 4-1 shows detailed bit status information. The Toggle Bit (DQ₂) is valid after the rising edge of the last WE# (or CE#) pulse of Write operation. See Figure 6-8 for Toggle Bit timing diagram and Figure 6-21 for a flowchart.

4.8.3 DQ₁

If an operation aborts during a Write-to-Buffer or Program Buffer-to-Flash operation, DQ₁ is set to '1'. To reset DQ₁ to '0', issue the Write-to-Buffer Abort Reset command to exit the abort state. A power-off/power-on cycle or a Hardware Reset (RST# = 0) will also clear DQ₁.

4.8.4 RY/BY#

The RY/BY# pin can be used to determine the status of a Program or Erase operation. The RY/BY# pin is valid after the rising edge of the final WE# pulse in the command sequence. If RY/BY# = 0, then the device is actively programming or erasing. If RY/BY# = 1, the device is in Read mode. The RY/BY# pin is an open drain output pin. This means several RY/BY# can be tied together with a pull-up resistor to V_{DD}.

TABLE 4-1: WRITE OPERATION STATUS

Status		DQ ₇ ¹	DQ ₆	DQ ₂ ¹	DQ ₁	RY/BY# ²
Normal Operation	Standard Program	DQ ₇ #	Toggle	No Toggle	0	0
	Standard Erase	0	Toggle	Toggle	N/A	0
Erase-Suspend Mode	Read from Erase-Suspended Block	1	No toggle	Toggle	N/A	1
	Read from Non- Erase-Suspended Block	Data	Data	Data	Data	1
	Program	DQ ₇ #	Toggle	N/A	N/A	0
Program Buffer-to-Flash	Busy	DQ ₇ # ³	Toggle	N/A	0	0
	Abort	DQ ₇ # ³	Toggle	N/A	1	0

1. DQ₇ and DQ₂ require a valid address when reading status information.
2. RY/BY# is an open drain pin. RY/BY# is high in Read mode, and Read in Erase-Suspend mode.
3. During a Program Buffer-to-Flash operation, the datum on the DQ₇ pin is the complement of DQ₇ of the last word loaded in the Write-Buffer using the Write-to-Buffer command.

4.9 Data Protection

The SST38VF6401B/6402B/6403B/6404B provide both hardware and software features to protect nonvolatile data from inadvertent writes.

4.9.1 HARDWARE DATA PROTECTION

4.9.1.1 Noise/Glitch Protection

A WE# or CE# pulse of less than 5 ns will not initiate a write cycle.

4.9.1.2 V_{DD} Power Up/Down Detection

The Write operation is inhibited when V_{DD} is less than 1.5V.

4.9.1.3 Write Inhibit Mode

Forcing OE# low, CE# high, or WE# high will inhibit the Write operation. This prevents inadvertent writes during power-up or power-down.

4.9.2 HARDWARE BLOCK PROTECTION

The SST38VF6402B and SST38VF6404B devices support top hardware block protection, which protects the top boot block of the device. For SST38VF6402B, the boot block consists of the top 32 KWord block, and for SST38VF6404B the boot block consists of the top two 4 KWord blocks (8 KWord total).

The SST38VF6401B and SST38VF6403B devices support bottom hardware block protection, which protects the bottom boot block of the device. For SST38VF6401B, the boot block consists of the bottom 32 KWord block, and for SST38VF6403B the Boot Block consists of the bottom two 4 KWord blocks (8 KWord total). The boot block addresses are described in Table 4-2.

TABLE 4-2: BOOT BLOCK ADDRESS RANGES

Product	Size	Address Range
Bottom Boot Uniform		
SST38VF6401B	32 KW	000000H-007FFFFH
Top Boot Uniform		
SST38VF6402B	32 KW	3F8000H-3FFFFFFH
Bottom Boot Non-Uniform		
SST38VF6403B	8 KW	000000H-001FFFFH
Top Boot Non-Uniform		
SST38VF6404B	8 KW	3FE000H-3FFFFFFH

Program and Erase operations are prevented on the Boot Block when WP# is low. If WP# is left floating, it is internally held high via a pull-up resistor. When WP# is high, the Boot Block is unprotected, which allows Program and Erase operations on that area.

4.9.3 HARDWARE RESET (RST#)

The RST# pin provides a hardware method of resetting the device to read array data. When the RST# pin is held low for at least T_{RP} , any in-progress operation will terminate and return to Read mode. When no internal Program/Erase operation is in progress, a minimum period of T_{RHR} is required after RST# is driven high before a valid Read can take place. See [Figure 6-15](#) for more information.

The interrupted Erase or Program operation must be re-initiated after the device resumes normal operation mode to ensure data integrity.

4.9.4 SOFTWARE DATA PROTECTION (SDP)

The SST38VF6401B/6402B/6403B/6404B devices implement the JEDEC approved Software Data Protection (SDP) scheme for all data alteration operations, such as Program and Erase. These devices are shipped with the Software Data Protection permanently enabled. See [Table 5-2](#) for the specific software command codes.

All Program operations require the inclusion of the three-byte sequence. The three-byte load sequence is used to initiate the Program operation, providing optimal protection from inadvertent Write operations. SDP for Erase operations is similar to Program, but a six-byte load sequence is required for Erase operations.

During SDP command sequence, invalid commands will abort the device to read mode within T_{RC} . The contents of DQ₁₅-DQ₈ can be V_{IL} or V_{IH} , but no other value, during any SDP command sequence.

The SST38VF6401B/6402B/6403B/6404B devices provide Bypass Mode, which allows for reduced Program and Erase command sequence lengths. In this mode, the SDP portion of Program and Erase command sequences are omitted. See “Bypass Mode” on [page 14](#) for further details.

4.10 Common Flash Memory Interface (CFI)

The SST38VF6401B/6402B/6403B/6404B contain Common Flash Memory Interface (CFI) information that describes the characteristics of the device. In order to enter the CFI Query mode, the system can write a one-byte sequence using a standard CFI Query Entry command. Once the device enters the CFI Query mode, the system can read CFI data at the addresses given in [Tables 5-4](#) through [5-7](#).

The system must write the CFI Exit command to return to Read mode. Note that the CFI Exit command is ignored during an internal Program or Erase operation. See [Table 5-2](#) for software command codes, [Figures 6-12](#) and [6-14](#) for timing waveform, and [Figures 6-22](#) and [6-23](#) for flowcharts.

4.11 Product Identification

The Product Identification mode identifies the devices as the SST38VF6401B, SST38VF6402B, SST38VF6403B, or SST38VF6404B, and the manufacturer as Microchip. See [Table 4-3](#) for specific address and data information. Product Identification mode is accessed through software operations. The software Product Identification operations identify the part, and can be useful when using multiple manufacturers in the same socket. For details, see [Table 5-2](#) for software operation, [Figure 6-11](#) for the software ID Entry and Read timing diagram, and [Figure 6-22](#) for the software ID Entry command sequence flowchart.

TABLE 4-3: PRODUCT IDENTIFICATION

	Add	Data	Add	Data	Add	Data
Manufacturer's ID	00H	BFH				
Device ID SST38VF6401B	01H	227EH	0EH	220CH	0FH	2200H
SST38VF6402B	01H	227EH	0EH	220CH	0FH	2201H
SST38VF6403B	01H	227EH	0EH	2210H	0FH	2200H
SST38VF6404B	01H	227EH	0EH	2210H	0FH	2201H

While in Product Identification mode, the Read Block Protection Status command determines if a block is protected. The status returned indicates if the block has been protected, but does not differentiate between Volatile Block Protection and Non-Volatile Block Protection. See [Table 5-2](#) for further details.

The Read-Irreversible Block-Lock Status command indicates if the Irreversible Block Command has been issued. If DQ₀ = 0, then the Irreversible Lock command has been previously issued.

In order to return to the standard Read mode, the software Product Identification mode must be exited. The exit is accomplished by issuing the software ID Exit command sequence, which returns the device to the Read mode. See [Table 5-2](#) for software command codes, [Figure 6-14](#) for timing waveform, and [Figures 6-22](#) and [6-23](#) for flowcharts.

4.12 Security ID

The SST38VF6401B/6402B/6403B/6404B devices offer a Security ID feature. The Secure ID space is divided into two segments — one factory programmed 128 bit segment and one user programmable 248 word segment. See [Table 4-4](#) for address information. The first segment is programmed and locked at Microchip and

contains a 128 bit Unique ID which uniquely identifies the device. The user segment is left un-programmed for the customer to program as desired.

TABLE 4-4: ADDRESS RANGE FOR SEC ID

	Size	Address
Microchip Unique ID	128 bits	000H – 007H
User	248 W	008H – 0FFH

The user segment of the Security ID can be programmed by first using the SEC ID Entry command to enter the Secure ID space. Once in the Secure ID space, for smaller data sets, use the Word-Program command to program data. To program larger sets of data more quickly, use the Write-Buffer Programming feature. Note that Bypass Mode is not available.

To detect end-of-write for the SEC ID, read the toggle bits. Do not use Data# Polling to detect end of Write. Once the programming is complete, lock the Sec ID by programming bit '0' in the PSR with the PSR Program command. Locking the Sec ID disables any corruption of this space. Note that regardless of whether or not the Sec ID is locked, the Sec ID segments can not be erased.

The Secure ID space can be queried by executing a three-byte command sequence with Enter Sec ID command (88H) at address 555H in the last byte sequence. To exit this mode, the Exit Sec ID command should be executed. Refer to [Table 5-2](#) for software commands and [Figures 6-22](#) and [6-23](#) for flow charts.

4.13 Bypass Mode

Bypass mode shortens the time needed to issue program and erase commands by reducing these commands to two write cycles each. After using the Bypass Entry command to enter the Bypass mode, only the Bypass Word-Program, Bypass Block Erase, Bypass Chip Erase, Erase-Suspend, and Erase-Resume commands are available. The Bypass Exit command exits Bypass mode. See [Table 5-2](#) for further details.

Entering Bypass Mode while already in Erase-Suspend limits the available commands. See [“Erase-Suspend/ Erase-Resume Commands”](#) on page 10 for more information.

4.14 Protection Settings Register (PSR)

The Protection Settings Register (PSR) is a user-programmable register that allows for further customization of the SST38VF6401B/6402B/6403B/6404B protection features. The 16-bit PSR provides four One Time Programmable (OTP) bits for users, each of which can be programmed individually. However, once an OTP bit is programmed to '0', the value cannot be changed back to a '1'. The other 12 bits of the PSR are reserved. See [Table 4-5](#) for the definition of all 16-bits of the PSR.

TABLE 4-5: PSR BIT DEFINITIONS

Bit	Default from Factory	Definition
DQ ₁₅ -DQ ₅	FFFh	Reserved
DQ ₄	1	VPB power-up / hardware reset state 0 = all protected 1 = all unprotected
DQ ₃	1	Reserved
DQ ₂	1	Password mode 0 = Password only mode 1 = Pass-Through mode
DQ ₁	1	Pass-Through mode 0 = Pass-Through only mode 1 = Pass-Through mode
DQ ₀	1	SEC ID Lock Out Bit 0 = locked 1 = unlocked

Note that DQ₄, DQ₂, DQ₁, DQ₀ do not have to be programmed at the same time. In addition, DQ₂ and DQ₁ cannot both be programmed to '0'. The valid combinations of states of DQ₂ and DQ₁ are shown in [Table 4-6](#).

TABLE 4-6: VALID DQ₂ AND DQ₁ COMBINATIONS

Combination	Definition
DQ ₂ , DQ ₁ = 11	Pass-Through mode (factory default)
DQ ₂ , DQ ₁ = 10	Pass-Through only mode
DQ ₂ , DQ ₁ = 01	Password only mode
DQ ₂ , DQ ₁ = 00	Not Allowed

The PSR can be accessed by issuing the PSR Entry command. Users can then use the PSR Program and PSR Read commands. The PSR Exit command must be issued to leave this mode. See [Table 5-2](#) for further details.

4.15 Individual Block Protection

The SST38VF6401B/6402B/6403B/6404B provide two methods for Individual Block protection: Volatile Block Protection and Non-Volatile Block Protection. Data in protected blocks cannot be altered.

4.15.1 VOLATILE BLOCK PROTECTION

The Volatile Block Protection feature provides a faster method than Non-Volatile Protection to protect and unprotect 32 KWord blocks. Each block has it's own Volatile Protection Bit (VPB). In the SST38VF6401B/6402B, the 32 KWord boot block also has a VPB. In the

SST38VF6403B/6404B devices, each of the two 4 KWord blocks in the 8 KWord boot area has its own VPB.

After using the Volatile Block Protection Mode Entry command to enter the Volatile Block Protection mode, individual VPBs can be set or reset with VPB Set/Clear, or be read with VPB Status Read. If the VPB is '0', then the block is protected from Program and Erase. If the VPB is '1', then the block is unprotected. The Volatile Block Protection Exit command must be issued to exit Volatile Block Protection mode. See [Table 5-2](#) for further details on the commands and [Figure 6-26](#) for a flow chart.

If the device experiences a hardware reset or a power cycle, all the VPBs return to their default state as determined by user-programmable bit DQ_4 in the PSR. If DQ_4 is '0', then all VPBs default to '0' (protected). If DQ_4 is '1', then all VPBs default to '1' (unprotected).

4.15.2 NON-VOLATILE BLOCK PROTECTION

The Non-Volatile Block Protection feature provides protection to individual blocks using Non-Volatile Protection Bits (NVPBs). Each block has its own Non-Volatile Protection Bit. In the SST38VF6401B/2, the 32 KWord boot block also has its own NVPB. In the SST38VF6403B/6404B, each 4 KWord block in the 8KWord boot area has its own NVPB. All NVPBs come from the factory set to '1', the unprotected state.

Use the Non-Volatile Block Protection Mode Entry command to enter the Non-Volatile Block Protection mode. Once in this mode, the NVPB Program command can be used to protect individual blocks by setting individual NVPBs to '0'. The time needed to program an NVPB is two times T_{BP} , which is a maximum of 20 μ s. The NVPB Status Read command can be used to check the protection state of an individual NVPB.

To change an NVPB to '1', the unprotected state, the NVPB must be erased using NVPBs Erase command. This command erases all NVPBs to '1' and can take up to 25 ms to complete. NVPB Program should be used to set the NVPBs of any blocks that are to be protected before exiting the Non-Volatile Block Protection mode. See [Table 5-2](#) and [Figure 6-27](#) for further details.

Upon a power cycle or hardware reset, the NVPBs retain their states. Memory areas that are protected using Non-Volatile Block Protection remain protected. The NVPB Program and NVPBs Erase commands are permanently disabled once the Irreversible Block Lock command is issued. See ["Irreversible Block Locking"](#) on [page 16](#) for further information.

4.16 Advanced Protection

The SST38VF6401B/6402B/6403B/6404B provide Advanced Protection features that allow users to implement conditional access to the NVPBs. Specifically, Advanced Protection uses the Global Lock Bit to pro-

tect the NVPBs. If the Global Lock bit is '0' then all the NVPBs states are frozen and cannot be modified in any mode. If the Global Lock bit is '1', then all the NVPBs can be modified in Non-Volatile Block Protection mode. After using the Global Lock of NVPBs Entry command to enter the Global Lock of NVPBs mode, the Global Lock Bit can be activated by issuing a Set Global Lock Bit command, which sets the Global Lock Bit to '0'. The Global Lock bit cannot be set to '1' with this command. The status of the bit can be read with the Global Lock Bit Status command. Use the Global Lock of NVPBs Exit command to exit Global Lock of NVPBs mode. See [Table 5-2](#) and [Figure 6-28](#) for further details.

The steps used to change the Global Lock Bit from '0' to '1', to allow access to the NVPBs, depend on whether the device has been set to use Pass-Through or Password mode. When using Advanced Protection, select either Pass-Through only mode or Password only mode by programming the DQ_2 and DQ_1 bits in the PSR. Although the factory default is Pass-Through mode ($DQ_2 = 1$, $DQ_1 = 1$), the user should explicitly chose either Pass-Through only mode ($DQ_2 = 1$, $DQ_1 = 0$), or Password only mode ($DQ_2 = 0$, $DQ_1 = 1$). Keeping the SST38VF6401B/6402B/6403B/6404B in the factory default Pass-Through mode leaves the device open to unauthorized changes of DQ_2 and DQ_1 in the PSR. See ["Protection Settings Register \(PSR\)"](#) on [page 14](#). for more information about the PSR.

4.16.1 PASS-THROUGH MODE ($DQ_2, DQ_1 = 1, 0$)

The Pass-Through Mode allows the Global Lock Bit state to be cleared to '1' by a power-down power-up sequence or a hardware reset (RST# pin = 0). No password is required in Pass-Through mode.

To set the Global Lock Bit to '0', use the Set Global Lock Bit command while in the Global Lock of NVPBs mode. Select the Pass-Through only mode by programming PSR bit $DQ_2 = 1$ and $DQ_1 = 0$.

4.16.2 PASSWORD MODE ($DQ_2, DQ_1 = 0, 1$)

In the Password Mode, the Global Lock Bit is set to '0' by the Set Global Lock Bit command, a power-down power-up sequence, or a hardware reset (RST# pin = 0). Select the Password only mode by programming PSR bit $DQ_2 = 0$ and $DQ_1 = 1$. Note that when the PSR Program command is issued in Password mode, the Global Lock bit is automatically set to '0'.

In contrast to the Pass-Through Mode, in the Password mode, the only way to clear the Global Lock Bit to '1' is to submit the correct 64-bit password using the Submit Password command in Password Commands Mode. The words of the password can be submitted in any order as long as each 16 bit section of the password is matched with its correct address. After the entire 64 bit password is submitted, the device takes approximately 1 μ s to verify the password. A subsequent Submit Password command cannot be issued until this verification time has elapsed.

The 64-bit password must be chosen by the user before programming the DQ₂ and DQ₁ OTP bits of the PSR to choose Password Mode. The default 64 bit password on the device from the factory is FFFFFFFFh.

Enter the Password Commands mode by issuing the Password Commands Entry command. Then, use the Password Program command to program the desired password. Use caution when programming the password because there is no method to reset the password to FFFFFFFFh. Once a password bit has been set to '0', it cannot be changed back to '1'. See [Table 5-2](#) for further details about Password-related commands.

The password can be read using the Password Read command to verify the desired password has been programmed. Microchip recommends testing the password before permanently choosing Password Mode.

To test the password, do the following:

1. Enter the Global Lock of NVPBs mode.
2. Set the Global Lock Bit to '0', and verify the value.
3. Exit the Global Lock of NVPBs mode.
4. Enter the Password Commands mode.
5. Submit the 64-bit password with the Submit Password command.
6. Wait 2 μ s for the device to verify the password.
7. Exit the Password Commands mode.
8. Re-enter the Global Lock of NVPBs mode
9. Read the Global Lock Bit with the Global Lock Bit Status Read command. The Global Lock bit should now be '1'.

After verifying the password, program the DQ₂ and DQ₁ OTP bits of the PSR to explicitly choose Password mode. Once the Password mode has been selected, the Password Read and Password Program commands are permanently disabled. There is no longer any method for reading or modifying the password. In addition, Microchip is unable to read or modify the password. If a Password Read command is issued while in Password mode, the data presented for each word of the password is FFFFh.

If the Password Mode is not explicitly chosen in the PSR, then the password can still be read and modified. Therefore, Microchip strongly recommends that users explicitly choose Password Mode in the PSR.

4.17 Irreversible Block Locking

The SST38VF6401B/6402B/6403B/6404B provides Irreversible Block Locking, a feature that allows users to customize the size of Read-Only Memory (ROM) on the device and provides more flexibility than One-Time Programmable (OTP) memory.

Applying Irreversible Block Locking turns user-selected memory areas into ROM by permanently disabling Program and Erase operations to these chosen areas. Any area that becomes ROM cannot be changed back to Flash.

Any memory blocks in the main memory, including boot blocks, can be irreversibly locked. In non-uniform boot block devices (SST38VF6403B and SST38VF6404B) each 4 KW block in the boot area can be irreversibly locked. If desired, all blocks in the main memory can be irreversibly locked.

To use Irreversible Block Locking do the following:

1. Global Lock Bit should be '1'. The Irreversible Block Lock command is disabled when Global Lock Bit is '0'.
2. Enter the Non-Volatile Block Protection mode.
3. Use the NVPB Program command to protect only the blocks that are to be changed into ROM.
4. Exit the Non-Volatile Block Protection mode.
5. Issue the Irreversible Block Lock command (see [Table 5-2](#) for details).

The Irreversible Block Lock command can only be used once. Issuing the command after the first time has no effect on the device.

Important: Once the Irreversible Block Lock command is used, the state of the NVPBs can no longer be changed or overridden. Therefore, the following features no longer have any effect on the device:

- Global Lock of NVPBs feature
- Password feature
- NVPB Program command
- NVPB Erase command
- DQ₂ and DQ₁ of PSR

In addition, WP# has no effect on any memory in the boot block area that has been irreversibly locked.

To verify whether the Irreversible Block Lock command has already been issued, enter the Product ID mode and read address 5FEH. If DQ₀ = 0, then Irreversible Block Lock has already been executed. When using this feature to determine if a specific block is ROM, use the NVPB Status Read.

5.0 OPERATIONS

TABLE 5-1: OPERATION MODES SELECTION

Mode	CE#	OE#	WE#	RST#	WP#	DQ	Address
Read	V _{IL}	V _{IL}	V _{IH}	H	X	D _{OUT}	A _{IN}
Program	V _{IL}	V _{IH}	V _{IL}	H	V _{IL} /V _{IH} ¹	D _{IN}	A _{IN}
Erase	V _{IL}	V _{IH}	V _{IL}	H	V _{IL} /V _{IH} ¹	X ²	Block address, XXH for Chip-Erase
Standby	V _{IH}	X	X	V _{IH}	X	High Z	X
Write Inhibit	X	V _{IL}	X	X	X	High Z/ D _{OUT}	X
Product Identification	X	X	V _{IH}	H	X	High Z/ D _{OUT}	X
Reset	X	X	X	L	X	High Z	X
Software Mode	V _{IL}	V _{IH}	V _{IL}	H	X	See Table 5-2	See Table 5-2

1. WP# can be V_{IL} when programming or erasing outside of the bootblock.
WP# must be V_{IH} when programming or erasing inside the bootblock area.
2. X can be V_{IL} or V_{IH}, but no other value.

TABLE 5-2: SOFTWARE COMMAND SEQUENCE (SHEET 1 OF 3)

Command Sequence	1st Bus Cycle		2nd Bus Cycle		3rd Bus Cycle		4th Bus Cycle		5th Bus Cycle		6th Bus Cycle		7th Bus Cycle	
	Addr ¹	Data ²	Addr ¹	Data ²	Addr ¹	Data ²	Addr ¹	Data ²	Addr ¹	Data ²	Addr ¹	Data ²	Addr ¹	Data ²
Read ³	WA	Data												
Page Read³	WA ₀	Data ₀	WA ₁	Data ₁	WA ₂	Data ₂	WA ₃	Data ₃						
Word-Program	555H	AAH	2AAH	55H	555H	A0H	WA	Data						
Reset	XXH	FOH												
Write-Buffer Programming														
Write-to-Buffer ⁴	555H	AAH	2AAH	55H	BA	25H	BA	WC	WA _X	Data	WA _X	Data	WA _X	Data
Program Buffer-to-Flash	BA _X	29H												
Write-to-Buffer Abort-Reset	555H	AAH	2AAH	55H	555H	F0H								
Bypass Mode ⁵														
Bypass Mode Entry	555H	AAH	2AAH	55H	555H	20H								
Bypass Word-Program	XXXH	A0H	WA	Data										
Bypass Block Erase	XXXH	80H	BA	30H										
Bypass Chip Erase	XXXH	80H	555H	10H										
Bypass Mode Exit	XXXH	90H	XXXH	00H										
Erase Related														
Block-Erase	555H	AAH	2AAH	55H	555H	80H	555H	AAH	2AAH	55H	BAX	30H		
Chip-Erase	555H	AAH	2AAH	55H	555H	80H	555H	AAH	2AAH	55H	555H	10H		
Erase Suspend	XXXH	B0H												
Erase Resume	XXXH	30H												

TABLE 5-2: SOFTWARE COMMAND SEQUENCE (CONTINUED) (SHEET 2 OF 3)

Command Sequence	1st Bus Cycle		2nd Bus Cycle		3rd Bus Cycle		4th Bus Cycle		5th Bus Cycle		6th Bus Cycle		7th Bus Cycle	
	Addr ¹	Data ²	Addr ¹	Data ²	Addr ¹	Data ²	Addr ¹	Data ²	Addr ¹	Data ²	Addr ¹	Data ²	Addr ¹	Data ²
Security ID														
SEC ID Entry ⁶	555H	AAH	2AAH	55H	555H	88H								
SEC ID Read^{3,7}	WA _x	Data												
SEC ID Exit	555H	AAH	2AAH	55H	555H	90H	XXH	00H						
Product Identification														
Software ID Entry ⁸	555H	AAH	2AAH	55H	555H	90H								
Manufacturer ID^{3,9}	X00	BFH												
Device ID^{3,9}	X01	Data												
Read Block Protection Status³	BAX02 ¹⁰	Data ¹¹												
Read Irreversible Block Lock Status³	5FEH	Data ¹²												
Read Global Lock Bit Status³	9FFH	Data ¹³												
Software ID Exit /CFI Exit ¹⁴	XXH	FOH												
Volatile Block Protection														
Volatile Block Protection Mode Entry	555H	AAH	2AAH	55H	555H	E0H								
Volatile Protection Bit (VPB) Set/ Clear	XXH	A0H	BA _x ¹⁵	Data ¹⁶										
VPB Status Read³	BA _x	Data ¹⁶												
Volatile Block Protection Mode Exit	XXH	90H	XXH	00H										
Non-Volatile Block Protection														
Non-Volatile Block Protection Mode Entry	555H	AAH	2AAH	55H	555H	C0H								
Non-Volatile Protect Bit (NVPB) Program	XXH	A0H	BA _x ¹⁵	00H										
Non-Volatile Protect Bits (NVPB) Erase ¹⁷	XXH	80H	00H	30H										
NVPB Status Read³	BA _x ¹⁵	Data ¹⁶												
Non-Volatile Block Protection Mode Exit	XXH	90H	XXH	00H										

TABLE 5-2: SOFTWARE COMMAND SEQUENCE (CONTINUED) (SHEET 3 OF 3)

Command Sequence	1st Bus Cycle		2nd Bus Cycle		3rd Bus Cycle		4th Bus Cycle		5th Bus Cycle		6th Bus Cycle		7th Bus Cycle	
	Addr ¹	Data ²	Addr ¹	Data ²	Addr ¹	Data ²	Addr ¹	Data ²	Addr ¹	Data ²	Addr ¹	Data ²	Addr ¹	Data ²
Global Lock of NVPBs														
Global Lock of NVPBs Entry	555H	AAH	2AAH	55H	555H	50H								
Set Global Lock Bit	XXH	A0H	XXH	00H										
Global Lock Bit Status Read³	XXXH	Data ¹³												
Global Lock of NVPBs Exit	XXH	90H	XXH	00H										
Password Commands														
Password Commands Mode Entry	555H	AAH	2AAH	55H	555H	60H								
Password Program ¹⁸	XXH	A0H	PWA _X	PWD _X										
Password Read³	PWA _X	PWD _X												
Submit Password ¹⁹	00H	25H	00H	03H	00H	PWD ₀	01H	PWD ₁	02H	PWD ₂	03H	PWD ₃	00H	29H
Password Commands Mode Exit	XXH	90H	XXH	00H										
Program and Settings Register (PSR)														
PSR Entry	555H	AAH	2AAH	55H	555H	40H								
PSR Program	XXH	A0H	XXXH	Data										
PSR Read³	XXH	Data												
PSR Exit	XXH	90H	XXH	00H										
CFI														
CFI Query Entry	55H	98H												
Software ID Exit/CFI Exit ¹⁴	XXH	F0H												
Irreversible Block Lock														
Irreversible Block Lock ²⁰	555H	AAH	2AAH	55H	555H	87H	XXH	00H						

1. Address format A₁₀-A₀ (Hex). Addresses A₁₁- A₂₁ can be V_{IL} or V_{IH}, but no other value, for the SST38VF6401B/6402B/6403B/6404B command sequence.
2. DQ₁₅-DQ₈ can be V_{IL} or V_{IH}, but no other value, for command sequence
3. All read commands are in ***Bold Italics***.
4. Total number of cycles in this command sequence depends on the number of words to be written to the buffer. Additional words are written by repeating Write Cycle 5. Address (WA_X) values for Write Cycle 6 and later must have the same A₂₁-A₄ values as WA_X in Write Cycle 5.
WC = Word Count. The value of WC is the number of words to be written into the buffer, minus 1. Maximum WC value is 15 (i.e. F Hex)
5. Erase-Suspend and Erase-Resume commands are also available in Bypass Mode.
6. Once in SEC ID mode, the Word-Program, Write-Buffer Programming, and Bypass Word-Program features can be used to program the SEC ID area.
7. Lock-out Status is read with A₇-A₀ = FFH. Unlocked: DQ₃ = 1 / Locked: DQ₃ = 0. Lock status can also be checked by reading Bit '0' in the PSR.
8. The device does not remain in Software Product ID Mode if powered down.
9. With A_{MS}-A₁ = 0; Microchip Manufacturer ID = 00BFH, is read with A₀ = 0, SST38VF6401B/6402B/6403B/6404B Device IDs are read with the results shown in [Table 4-3 on page 13](#).
10. BA_{X02}: A_{MS}-A₁₅ = Block Address; A₁₄-A₈ = xxxxxx; A₇-A₀ = 02

11. Data = 00H unprotected block; Data = 01H protected block.
12. DQ₀ = 0 means the Irreversible Block Lock command has been previously used. DQ₀ = 1 means the Irreversible Block Lock command has not yet been used.
13. DQ₀ = 0 means that the Global Lock Bit is locked. DQ₀ = 1 means that the Global Lock Bit is unlocked.
14. Both Software ID Exit operations are equivalent.
15. For Non-Uniform Boot Block devices (i.e. 8 KWord size), in the boot area, use BA_X = Block Address.
16. DQ₀ = 0 means protected; DQ₀ = 1 means unprotected
17. Erases all NVPBs to '1' (unprotected)
18. Entire two-bus cycle sequence must be entered for each portion of the password.
19. Entire password sequence required for validation. The word order doesn't matter as long as the Address and Data pair match.
20. Global Lock Bit must be '1' before executing this command.

Note: Table 5-2 uses the following abbreviations:

X = Don't care (V_{IL} or V_{IH}, but no other value).

BA_X = Block Address; uses A_{MS}-A₁₅ address lines

WA = Word Address

WC = Word Count

PWA_X = Password Address; PWA_X = PWA₀, PWA₁, PWA₂ or PWA₃; A1 and A0 are used to select each 16-bit portion of the password

PWD_X = Password Data; PWD_X = PSWD₀, PWD₁, PWD₂, or PWD₃

A_{MS} = Most significant Address

TABLE 5-3: PROTECTION PRIORITY FOR MAIN ARRAY

NVPB ¹	VPB ¹	Protection State of Block
protect	X	protected
X	protect	protected
unprotect	unprotect	unprotected

1. X = protect or unprotect

TABLE 5-4: CFI QUERY IDENTIFICATION STRING¹ FOR SST38VF6401B/6402B/6403B/6404B

Address	Data	Description
10H	0051H	Query Unique ASCII string "QRY"
11H	0052H	
12H	0059H	
13H	0002H	Primary OEM command set
14H	0000H	
15H	0040H	Address for Primary Extended Table
16H	0000H	
17H	0000H	Alternate OEM command set (00H = none exists)
18H	0000H	
19H	0000H	Address for Alternate OEM Extended Table (00H = none exists)
1AH	0000H	

1. Refer to CFI publication 100 for more details.

TABLE 5-5: SYSTEM INTERFACE INFORMATION FOR SST38VF6401B/6402B/6403B/6404B

Address	Data	Description
1BH	0027H	V _{DD} Min (Program/Erase) DQ ₇ -DQ ₄ : Volts, DQ ₃ -DQ ₀ : 100 millivolts
1CH	0036H	V _{DD} Max (Program/Erase) DQ ₇ -DQ ₄ : Volts, DQ ₃ -DQ ₀ : 100 millivolts
1DH	0000H	V _{PP} min. (00H = no V _{PP} pin)
1EH	0000H	V _{PP} max. (00H = no V _{PP} pin)
1FH	0003H	Typical time out for Word-Program 2 ^N μs (2 ³ = 8 μs)
20H	0003H	Typical time out for min. size buffer program 2 ^N μs (00H = not supported)
21H	0004H	Typical time out for individual Block-Erase 2 ^N ms (2 ⁴ = 16 ms)
22H	0005H	Typical time out for Chip-Erase 2 ^N ms (2 ⁵ = 32 ms)
23H	0001H	Maximum time out for Word-Program 2 ^N times typical (2 ¹ x 2 ³ = 16 μs)
24H	0003H	Maximum time out for buffer program 2 ^N times typical
25H	0001H	Maximum time out for individual Block-Erase 2 ^N times typical (2 ¹ x 2 ⁴ = 32 ms)
26H	0001H	Maximum time out for Chip-Erase 2 ^N times typical (2 ¹ x 2 ⁵ = 64 ms)

TABLE 5-6: DEVICE GEOMETRY INFORMATION FOR SST38VF6401B/6402B/6403B/6404B

Address	Data	Description
27H	0017H	Device size = 2 ^N Bytes (17H = 23; 2 ²³ = 8 MByte)
28H	0001H	Flash Device Interface description; 0001H = x16-only asynchronous interface
29H	0000H	
2AH	0005H	Maximum number of bytes in multi-byte write = 2 ^N (00H = not supported)
2BH	0000H	
2CH	000xH	Number of Erase Block regions in the device (01H = uniform boot device, 02H = non-uniform boot device).
2DH	00xxH	Erase Block Region 1 Information
2EH	000xH	007FH, 0000H, 0000H, 0001H, for SST38VF6401B/6402B
2FH	00x0H	0007H, 0000H, 0020H, 0000H for SST38VF6403B/6404B
30H	000xH	
31H		Erase Block Region 2 Information
32H		0000H, 0000H, 0000H, 0000H, for SST38VF6401B/6402B
33H		007EH, 0000H, 0000H, 0001H for SST38VF6403B/6404B
34H		

SST38VF6401B / SST38VF6402B / SST38VF6403B / SST38VF6404B

**TABLE 5-7: PRIMARY VENDOR-SPECIFIC EXTENDED INFORMATION FOR SST38VF6401B/
6402B/6403B/6404B**

Address	Data	Description
40H	0050H	Query-unique ASCII string "PRI"
41H	0052H	
42H	0049H	
43H	FFFFH	Reserved
44H	FFFFH	Reserved
45H	0000H	Reserved
46H	0002H	Erase Suspend 0 = Not supported 1 = Only read during Erase Suspend, 2 = Read and Program during Erase Suspend.
47H	0001H	Individual Block Protection 0 = Not supported 1 = Supported
48H	0000H	Reserved
49H	0008H	Protection 0008H = Advanced
4AH	0000H	Simultaneous Operation 00 = Not supported
4BH	0000H	Burst Mode 00 = Not supported
4CH	0002H	Page Mode 00 = Not supported 02 = 8 Word page.
4DH	0000H	Acceleration Supply Minimum 00 = Not supported
4EH	0000H	Acceleration Supply Maximum 00 = Not supported
4FH	00XXH	Top / Bottom Boot Block 02H = 8 KWord Bottom Boot 03H = 8 KWord Top Boot 04H = Uniform (32 KWord) Bottom Boot 05H = Uniform (32 KWord) Top Boot
50H	0000H	Program Suspend 00H = Not Supported 01H = Supported

Absolute Maximum Stress Ratings (Applied conditions greater than those listed under “Absolute Maximum Stress Ratings” may cause permanent damage to the device. This is a stress rating only and functional operation of the device at these conditions or conditions greater than those defined in the operational sections of this data sheet is not implied. Exposure to absolute maximum stress rating conditions may affect device reliability.)

Temperature Under Bias	-55°C to +125°C
Storage Temperature	-65°C to +150°C
D. C. Voltage on Any Pin to Ground Potential	-0.5V to $V_{DD}+0.5V$
Transient Voltage (<20 ns) on Any Pin to Ground Potential	-2.0V to $V_{DD}+2.0V$
Voltage on A ₉ Pin to Ground Potential	-0.5V to 12.5V
Voltage on RST# Pin to Ground Potential	-0.5V to 12.5V
Voltage on WP# Pin to Ground Potential	-0.5V to 12.5V
Package Power Dissipation Capability ($T_A = 25^\circ C$)	1.0W
Surface Mount Solder Reflow Temperature	260°C for 10 seconds
Output Short Circuit Current ¹	50 mA

1. Outputs shorted for no more than one second. No more than one output shorted at a time.

TABLE 5-8: OPERATING RANGE

Range	Ambient Temp	V_{DD}
Commercial	0°C to +70°C	2.7-3.6V
Industrial	-40°C to +85°C	2.7-3.6V

TABLE 5-9: AC CONDITIONS OF TEST¹

Input Rise/Fall Time	Output Load
5ns	$C_L = 30 \text{ pF}$

1. See Figures 6-17 and 6-18

5.1 Power-Up Specifications

All functionalities and DC specifications are specified for a V_{DD} ramp rate faster than 1V per 100 ms (0V to 3V in less than 300 ms). If the V_{DD} ramp rate is slower than 1V per 100 ms, a hardware reset is required. The

recommended V_{DD} power-up to RESET# high time should be greater than 100 μ s to ensure a proper reset. See Table 5-10 and Figure 5-1 for more information.

TABLE 5-10: RECOMMENDED SYSTEM POWER-UP TIMINGS

Symbol	Parameter	Minimum	Units
$T_{PU-READ}^1$	Power-up to Read Operation	100	μ s
$T_{PU-WRITE}^1$	Power-up to Erase/Program Operation	100	μ s

1. This parameter is measured only for initial qualification and after a design or process change that could affect this parameter.

FIGURE 5-1: POWER-UP DIAGRAM

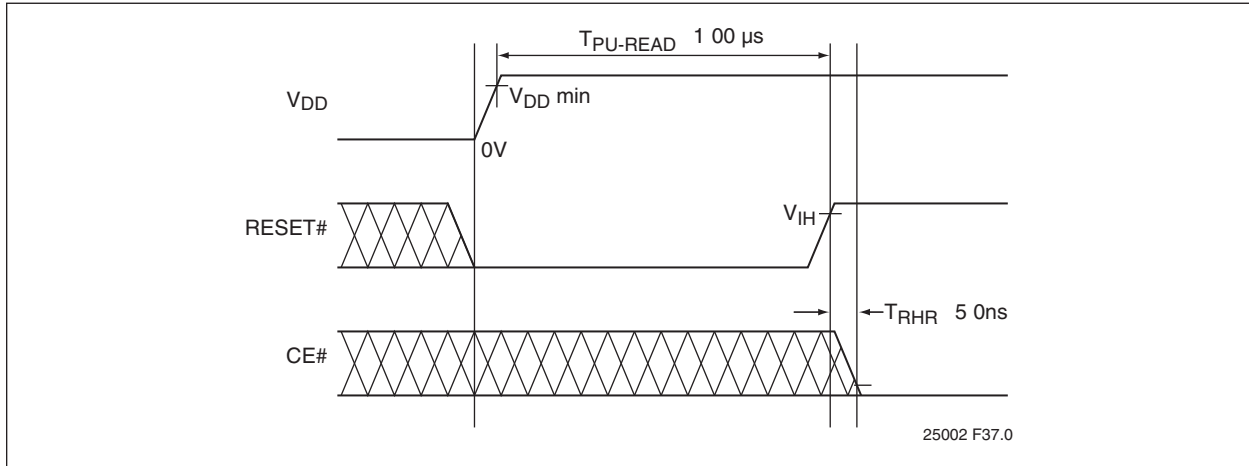

5.2 DC Characteristics

TABLE 5-11: DC OPERATING CHARACTERISTICS $V_{DD} = 2.7-3.6V^1$

Symbol	Parameter	Limits			Test Conditions
		Min	Max	Units	
I_{DD}	Power Supply Current Read ³		30	mA	Address input= V_{ILT}/V_{IHT}^2 , $V_{DD}=V_{DD}$ Max CE#= V_{IL} , OE#=WE#= V_{IH} at f= 5 MHz
	Intra-Page Read @5 MHz		2.5	mA	CE#= V_{IL} , OE#=WE#= V_{IH}
	Intra-Page Read @40 MHz		20	mA	CE#= V_{IL} , OE#=WE#= V_{IH}
	Program and Erase		35	mA	CE#=WE#= V_{IL} , OE#= V_{IH}
	Program-Write-Buffer-to-Flash		50	mA	CE#=WE#= V_{IL} , OE#= V_{IH}
I_{SB}	Standby V_{DD} Current		40	μA	CE#= V_{IHC} , $V_{DD}=V_{DD}$ Max
I_{ALP}	Auto Low Power		40	μA	CE#= V_{ILC} , $V_{DD}=V_{DD}$ Max All inputs= V_{SS} or V_{DD} , WE#= V_{IHC}
I_{LI}	Input Leakage Current		1	μA	$V_{IN}=GND$ to V_{DD} , $V_{DD}=V_{DD}$ Max
I_{LIW}	Input Leakage Current on WP# pin and RST#		10	μA	WP#=GND to V_{DD} or RST#=GND to V_{DD}
I_{LO}	Output Leakage Current		10	μA	$V_{OUT}=GND$ to V_{DD} , $V_{DD}=V_{DD}$ Max
V_{IL}	Input Low Voltage		0.8	V	$V_{DD}=V_{DD}$ Min
V_{ILC}	Input Low Voltage (CMOS)		0.3	V	$V_{DD}=V_{DD}$ Max
V_{IH}	Input High Voltage	$0.7V_{DD}$		V	$V_{DD}=V_{DD}$ Max
V_{IHC}	Input High Voltage (CMOS)	$V_{DD}-0.3$		V	$V_{DD}=V_{DD}$ Max
V_{OL}	Output Low Voltage		0.2	V	$I_{OL}=100 \mu A$, $V_{DD}=V_{DD}$ Min
V_{OH}	Output High Voltage	$V_{DD}-0.2$		V	$I_{OH}=-100 \mu A$, $V_{DD}=V_{DD}$ Min

1. Typical conditions for the Active Current shown on the front page of the data sheet are average values at 25°C (room temperature), and $V_{DD} = 3V$. Not 100% tested.
2. See [Figure 6-22](#)
3. The I_{DD} current listed is typically less than 2mA/MHz, with OE# at V_{IH} . Typical V_{DD} is 3V.

TABLE 5-12: CAPACITANCE ($T_A = 25^\circ C$, F=1 MHZ, OTHER PINS OPEN)

Parameter	Description	Test Condition	Maximum
$C_{I/O}^1$	I/O Pin Capacitance	$V_{I/O} = 0V$	12 pF
C_{IN}^1	Input Capacitance	$V_{IN} = 0V$	6 pF

1. This parameter is measured only for initial qualification and after a design or process change that could affect this parameter.

TABLE 5-13: RELIABILITY CHARACTERISTICS

Symbol	Parameter	Minimum Specification	Units	Test Method
$N_{END}^{1,2}$	Endurance	100,000	Cycles	JEDEC Standard A117
T_{DR}^1	Data Retention	100	Years	JEDEC Standard A103
I_{LTH}^1	Latch Up	$100 + I_{DD}$	mA	JEDEC Standard 78

1. This parameter is measured only for initial qualification and after a design or process change that could affect this parameter.
2. N_{END} endurance rating is qualified as 100,000 cycles minimum per block.

6.0 AC CHARACTERISTICS

TABLE 6-1: READ CYCLE TIMING PARAMETERS $V_{DD} = 2.7-3.6V$

Symbol	Parameter	Min	Max	Units
T_{RC}	Read Cycle Time	70		ns
T_{CE}	Chip Enable Access Time		70	ns
T_{AA}	Address Access Time		70	ns
T_{PACC}	Page Access Time		25	ns
T_{OE}	Output Enable Access Time		25	ns
T_{CLZ}^1	CE# Low to Active Output	0		ns
T_{OLZ}^1	OE# Low to Active Output	0		ns
T_{CHZ}^1	CE# High to High-Z Output		20	ns
T_{OHZ}^1	OE# High to High-Z Output		20	ns
T_{OH}^1	Output Hold from Address Change	0		ns
T_{RP}^1	RST# Pulse Width	500		ns
T_{RHR}^1	RST# High before Read	50		ns
$T_{RYE}^{1,2}$	RST# Pin Low to Read Mode		20	μs
T_{RY}^1	RST# Pin Low to Read Mode – not during Program or Erase algorithms.		500	ns
T_{RPD}^1	RST# Input Low to Standby mode	20		μs
T_{RB}^1	RY / BY# Output high to CE# / OE# pin Low	0		ns
T_{PWD}	Delay for each password check	1		μs

1. This parameter is measured only for initial qualification and after a design or process change that could affect this parameter.
2. This parameter applies to Block-Erase and Program operations.
This parameter does not apply to Chip-Erase operations.

TABLE 6-2: PROGRAM/ERASE CYCLE TIMING PARAMETERS

Symbol	Parameter	Min	Max	Units
T _{BP}	Word-Program Time		10	μs
T _{WBP} ¹	Program Buffer-to-Flash Time		40	μs
T _{AS}	Address Setup Time	0		ns
T _{AH}	Address Hold Time	30		ns
T _{CS}	WE# and CE# Setup Time	0		ns
T _{CH}	WE# and CE# Hold Time	0		ns
T _{OES}	OE# High Setup Time	0		ns
T _{OEH}	OE# High Hold Time	10		ns
T _{CP}	CE# Pulse Width	40		ns
T _{WP}	WE# Pulse Width	40		ns
T _{WPH} ²	WE# Pulse Width High	30		ns
T _{CPH} ²	CE# Pulse Width High	30		ns
T _{DS}	Data Setup Time	30		ns
T _{CEPH}	CE# Pulse Width High During Toggle Bit Polling	20		ns
T _{OEPH}	OE# Pulse Width High During Toggle bit Polling	20		ns
T _{DH} ²	Data Hold Time	0		ns
T _{IDA} ²	Software ID, Volatile Protect, Non-Volatile Protect, Global Lock Bit, Password mode, Lock Bit, Bypass Entry, and Exit Times		150	ns
T _{BE}	Block-Erase		25	ms
T _{SCE}	Chip-Erase		50	ms
T _{BUSY} ²	CE# High or WE# High to RY / BY# Low	90		ns

1. Effective programming time is 2.5 μs per word if 16-words are programmed during this operation.
2. This parameter is measured only for initial qualification and after a design or process change that could affect this parameter.

FIGURE 6-1: READ CYCLE TIMING DIAGRAM

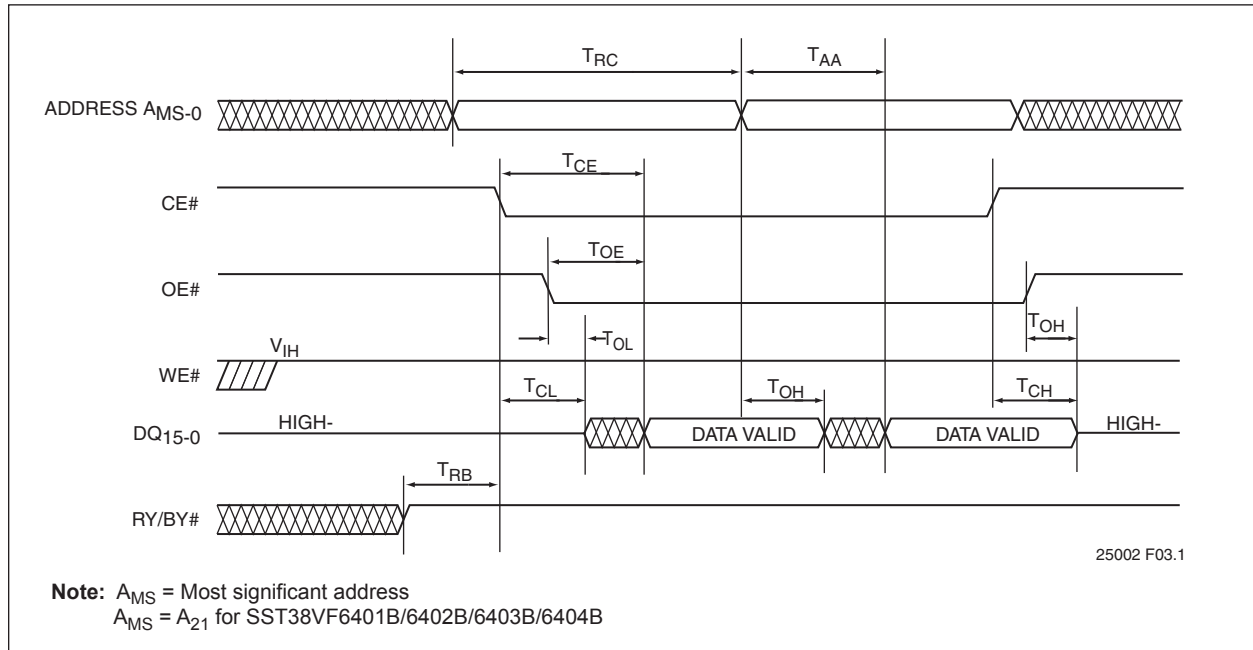

FIGURE 6-2: PAGE READ TIMING DIAGRAM



FIGURE 6-3: WE# CONTROLLED PROGRAM CYCLE TIMING DIAGRAM



FIGURE 6-4: CE# CONTROLLED PROGRAM CYCLE TIMING DIAGRAM

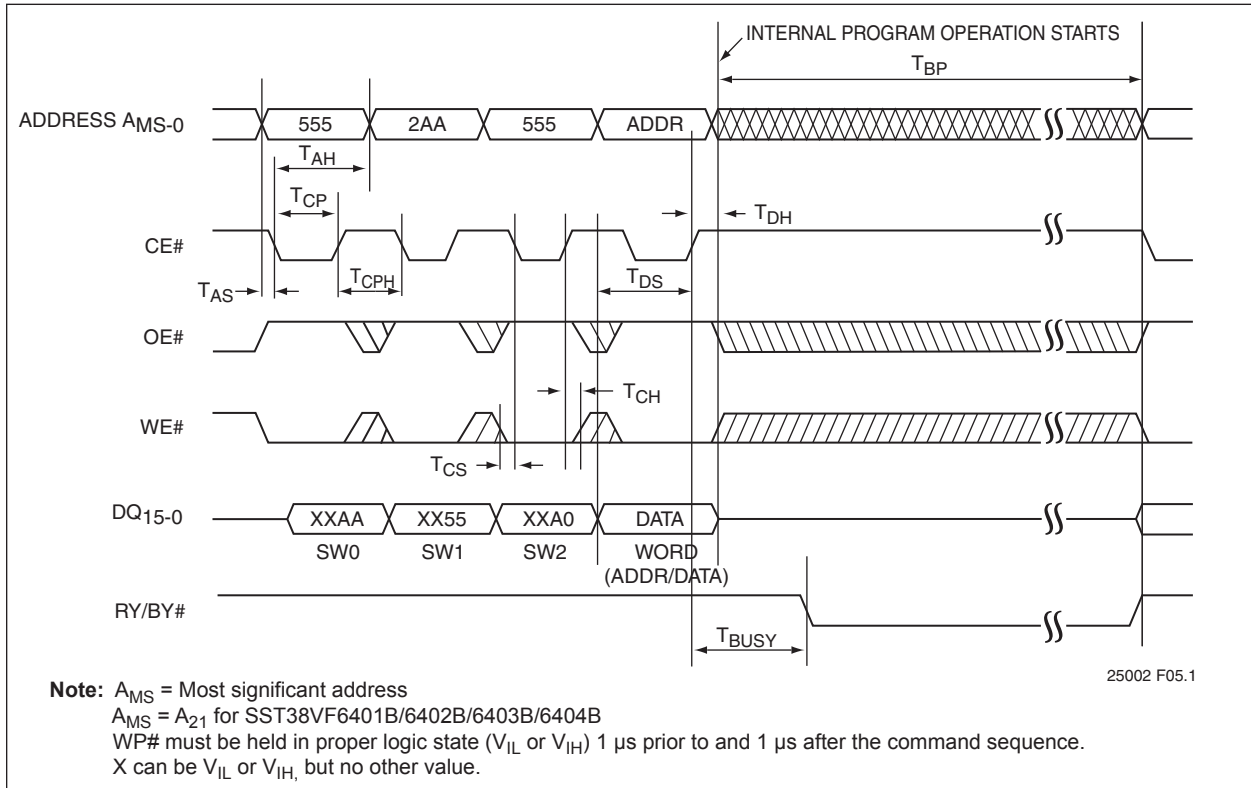

FIGURE 6-5: WE# CONTROLLED WRITE-BUFFER CYCLE TIMING DIAGRAM

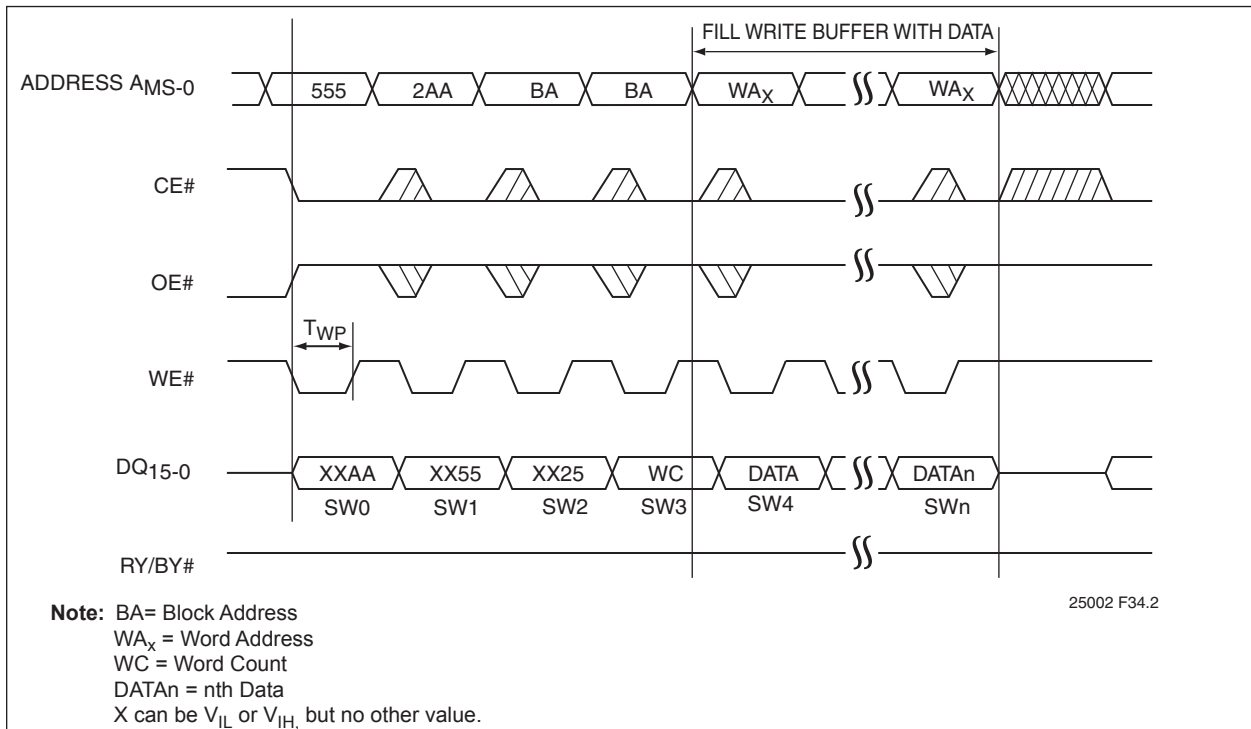

FIGURE 6-6: WE# CONTROLLED PROGRAM-WRITE-BUFFER-TO-FLASH CYCLE TIMING DIAGRAM

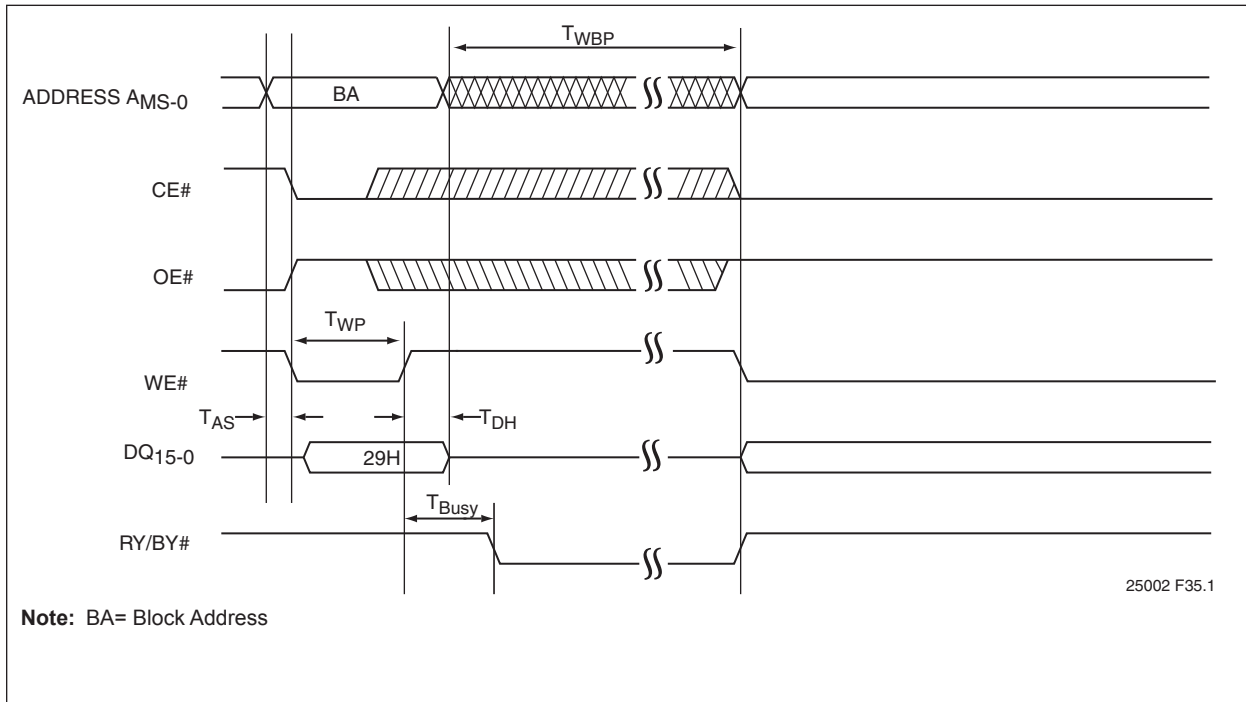

FIGURE 6-7: DATA# POLLING TIMING DIAGRAM



FIGURE 6-8: TOGGLE BITS TIMING DIAGRAM



FIGURE 6-9: WE# CONTROLLED CHIP-ERASE TIMING DIAGRAM



FIGURE 6-10: WE# CONTROLLED BLOCK-ERASE TIMING DIAGRAM

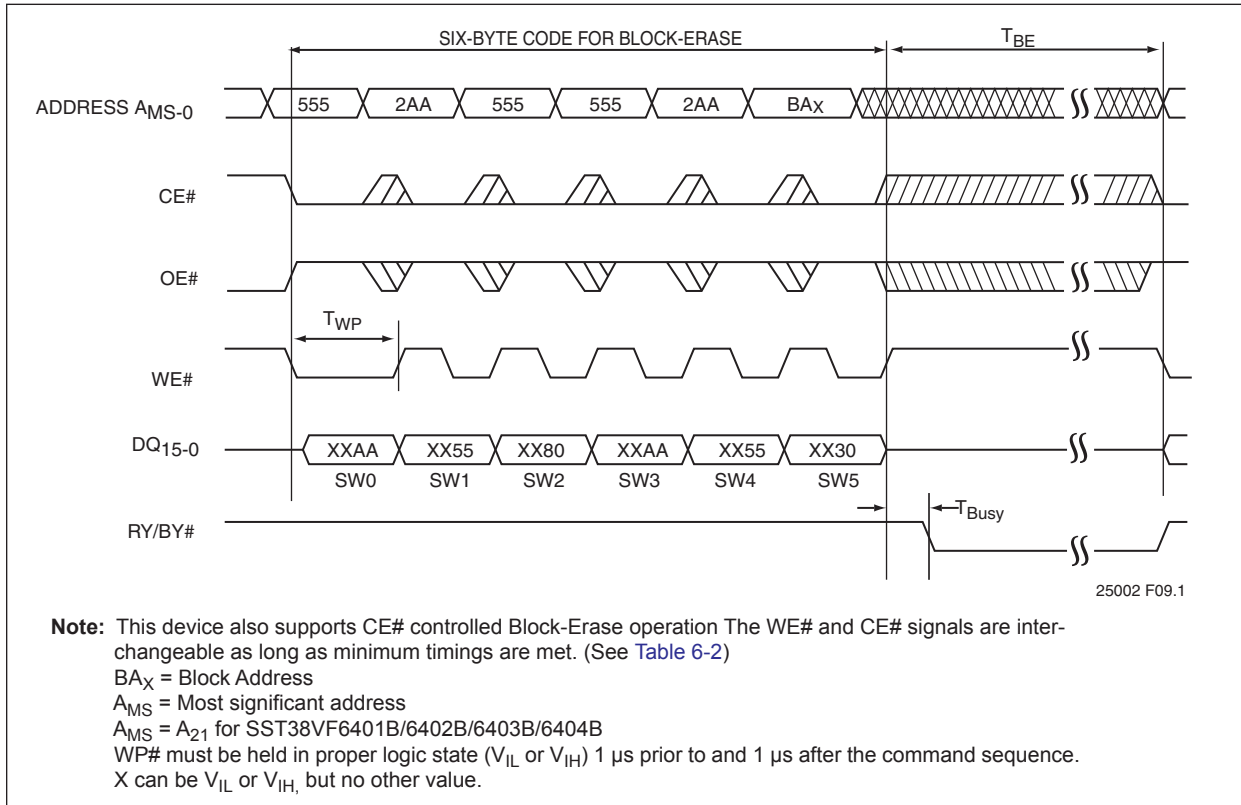

FIGURE 6-11: SOFTWARE ID ENTRY AND READ

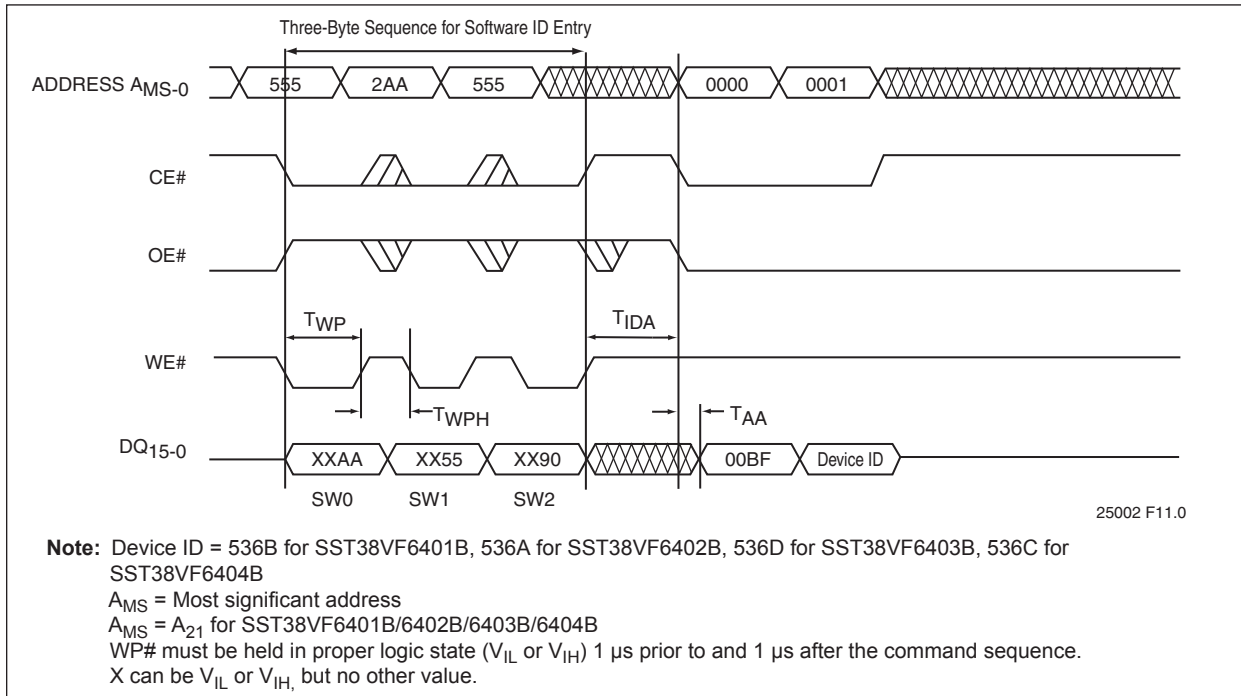

FIGURE 6-12: CFI QUERY ENTRY AND READ



FIGURE 6-13: SOFTWARE ID EXIT/CFI EXIT



FIGURE 6-14: SEC ID ENTRY



FIGURE 6-15: RST# TIMING DIAGRAM (WHEN NO INTERNAL OPERATION IS IN PROGRESS)



FIGURE 6-16: RST# TIMING DIAGRAM (DURING PROGRAM OR ERASE OPERATION)



FIGURE 6-17: AC INPUT/OUTPUT REFERENCE WAVEFORMS

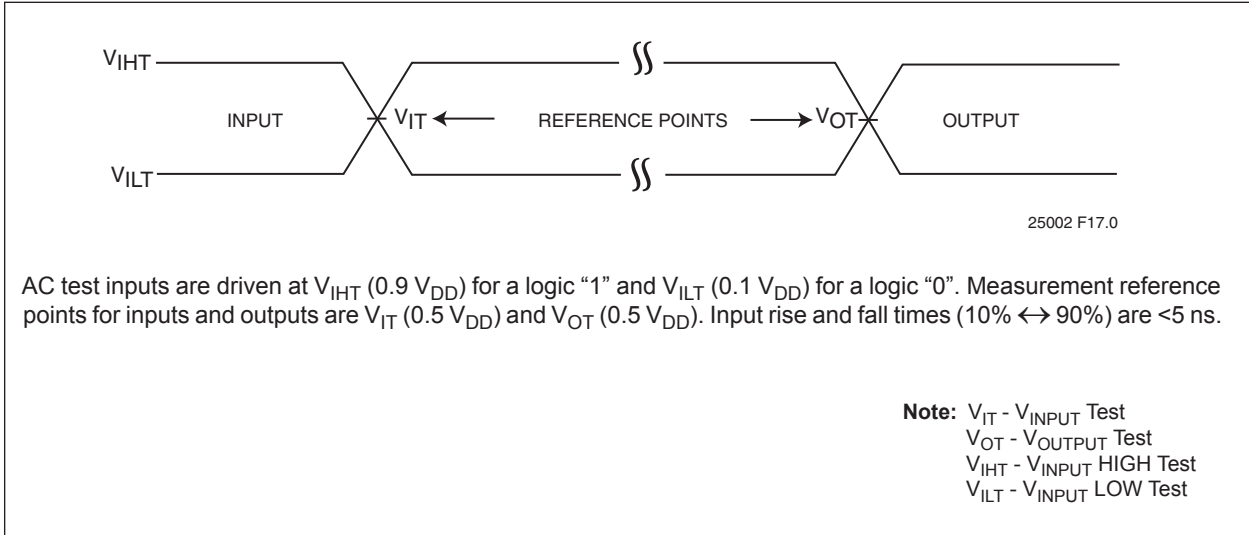

FIGURE 6-18: A TEST LOAD EXAMPLE

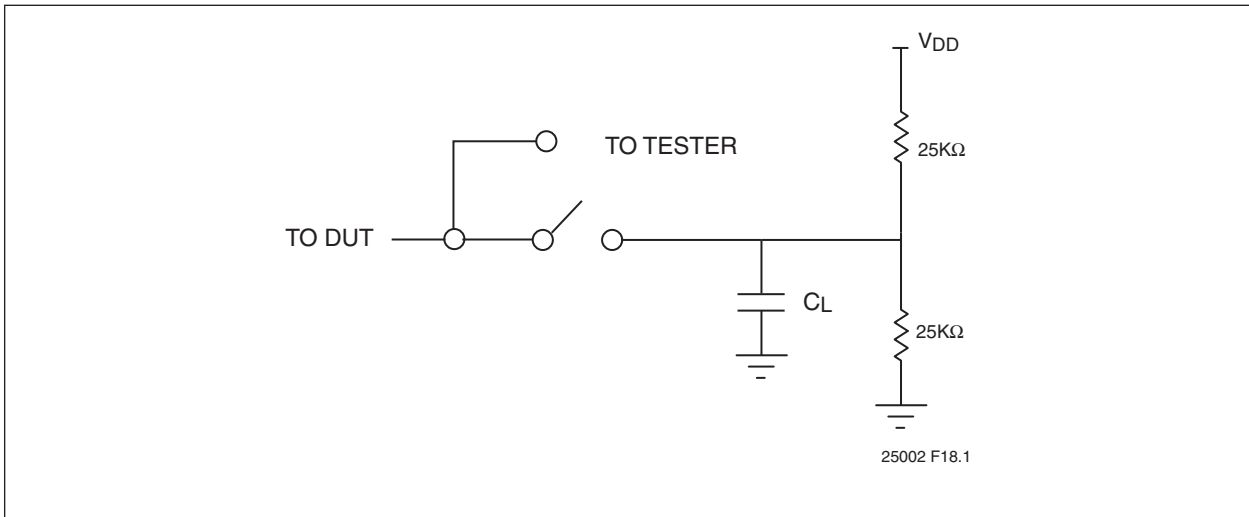

FIGURE 6-19: WORD-PROGRAM ALGORITHM



FIGURE 6-20: WRITE-BUFFER PROGRAMMING

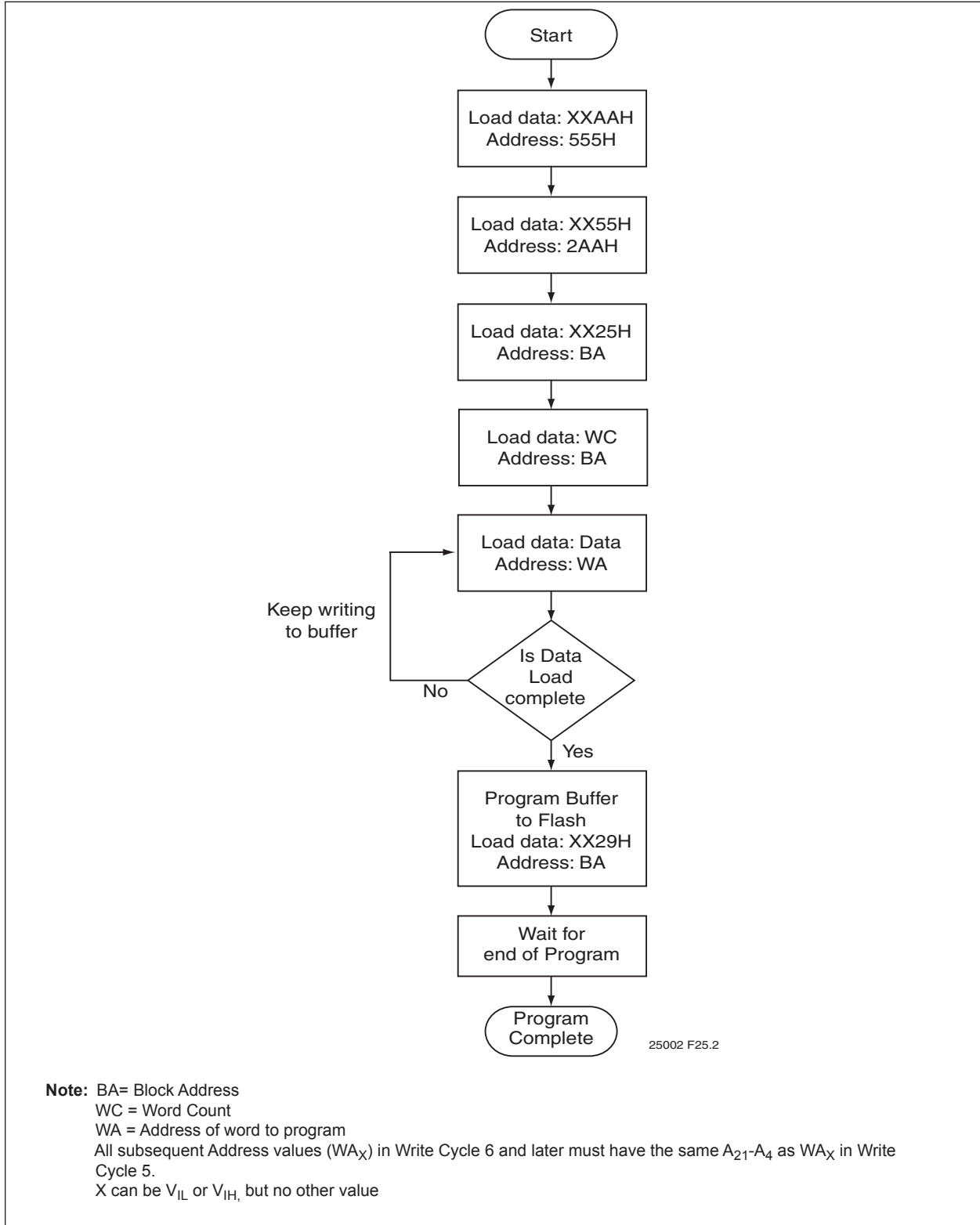

FIGURE 6-21: WAIT OPTIONS

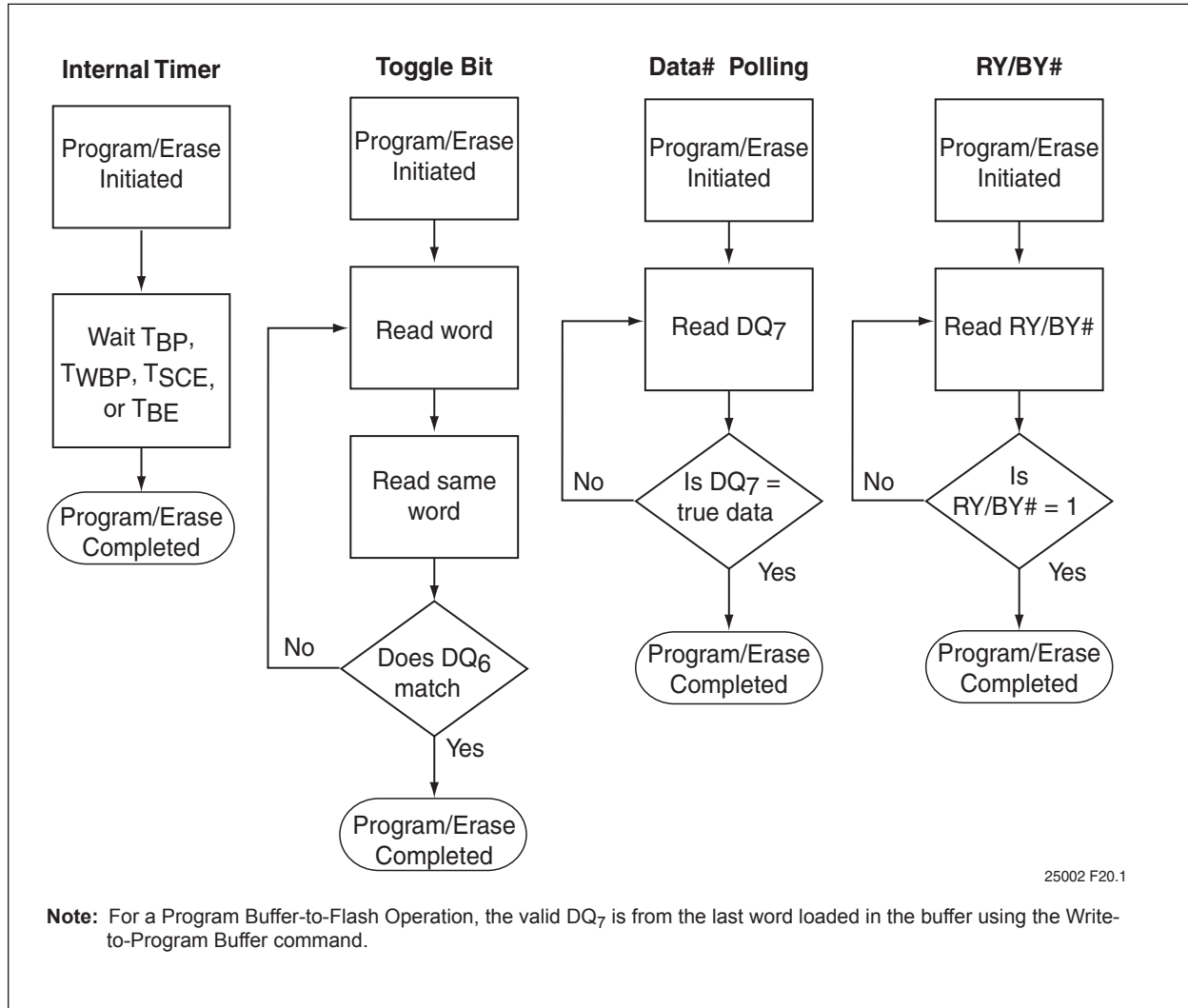

FIGURE 6-22: CFI/SEC ID/SOFTWARE ID ENTRY COMMAND FLOWCHARTS



FIGURE 6-23: SOFTWARE ID/CFI/SEC ID EXIT COMMAND FLOWCHARTS



FIGURE 6-24: ERASE COMMAND SEQUENCE

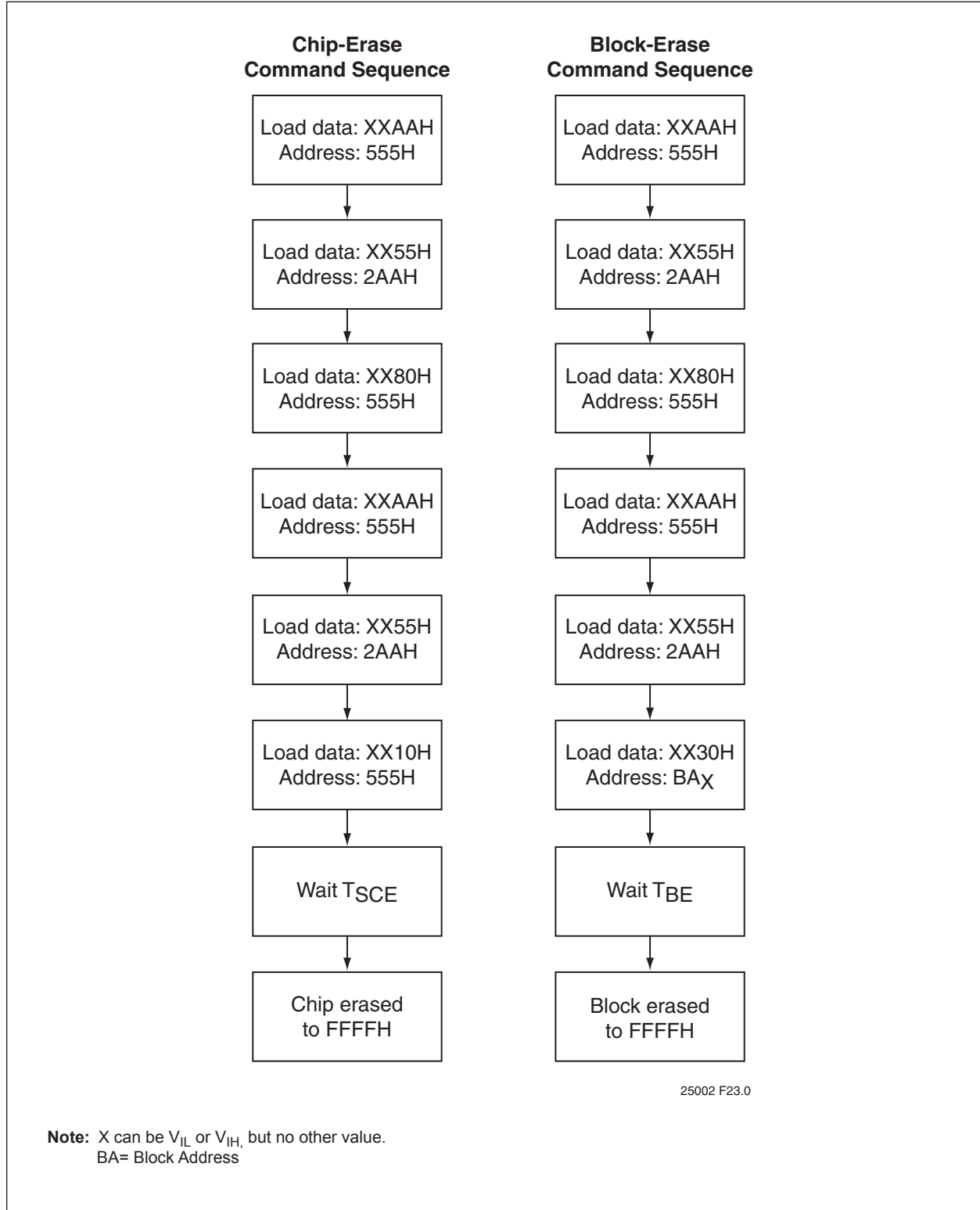

FIGURE 6-25: ERASE SUSPEND/RESUME



FIGURE 6-26: VOLATILE BLOCK PROTECTION



FIGURE 6-27: NON-VOLATILE BLOCK PROTECT MODE



FIGURE 6-28: GLOBAL LOCK OF NVPBS

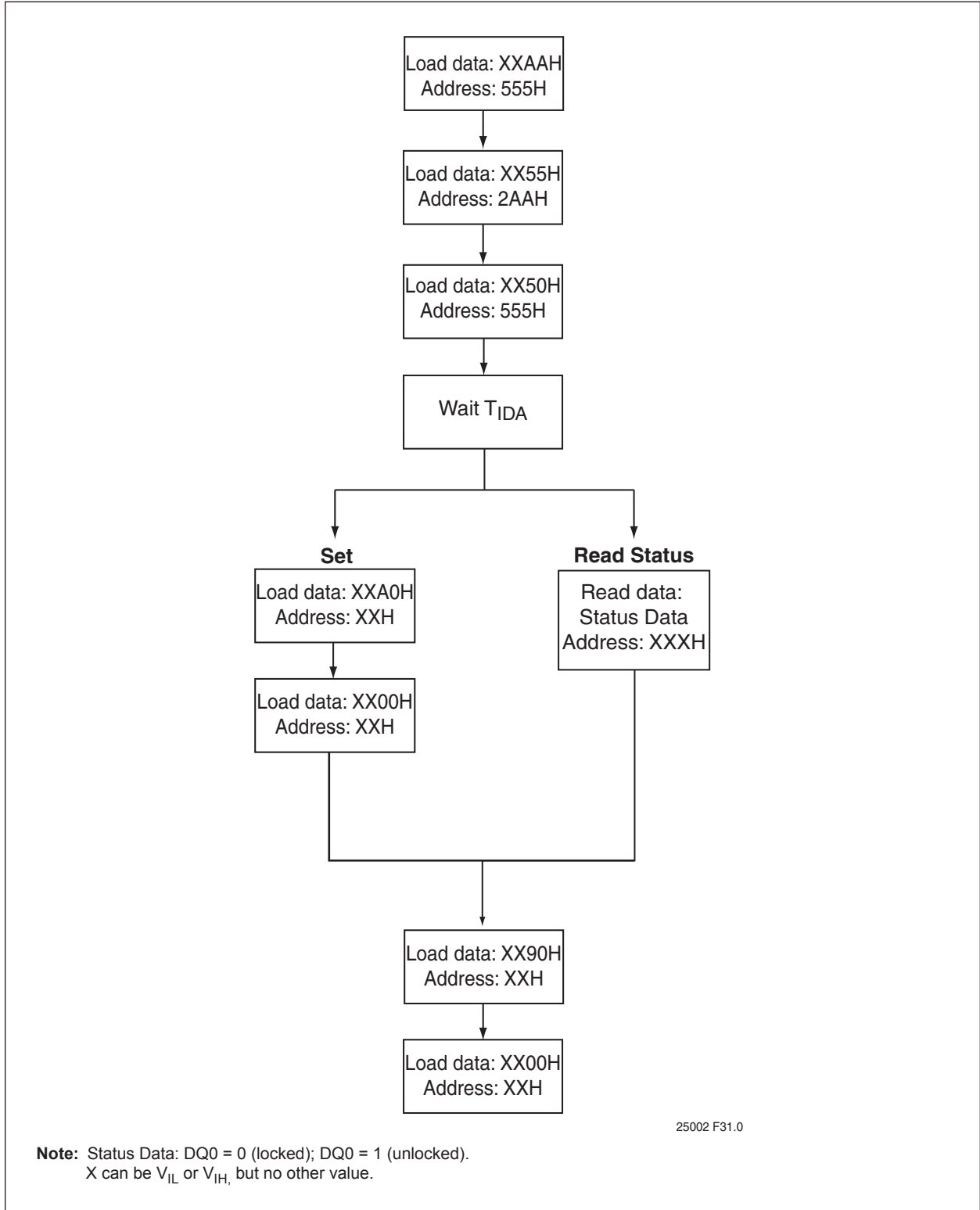

FIGURE 6-29: PASSWORD OPERATIONS (PROGRAM, READ, SUBMIT)

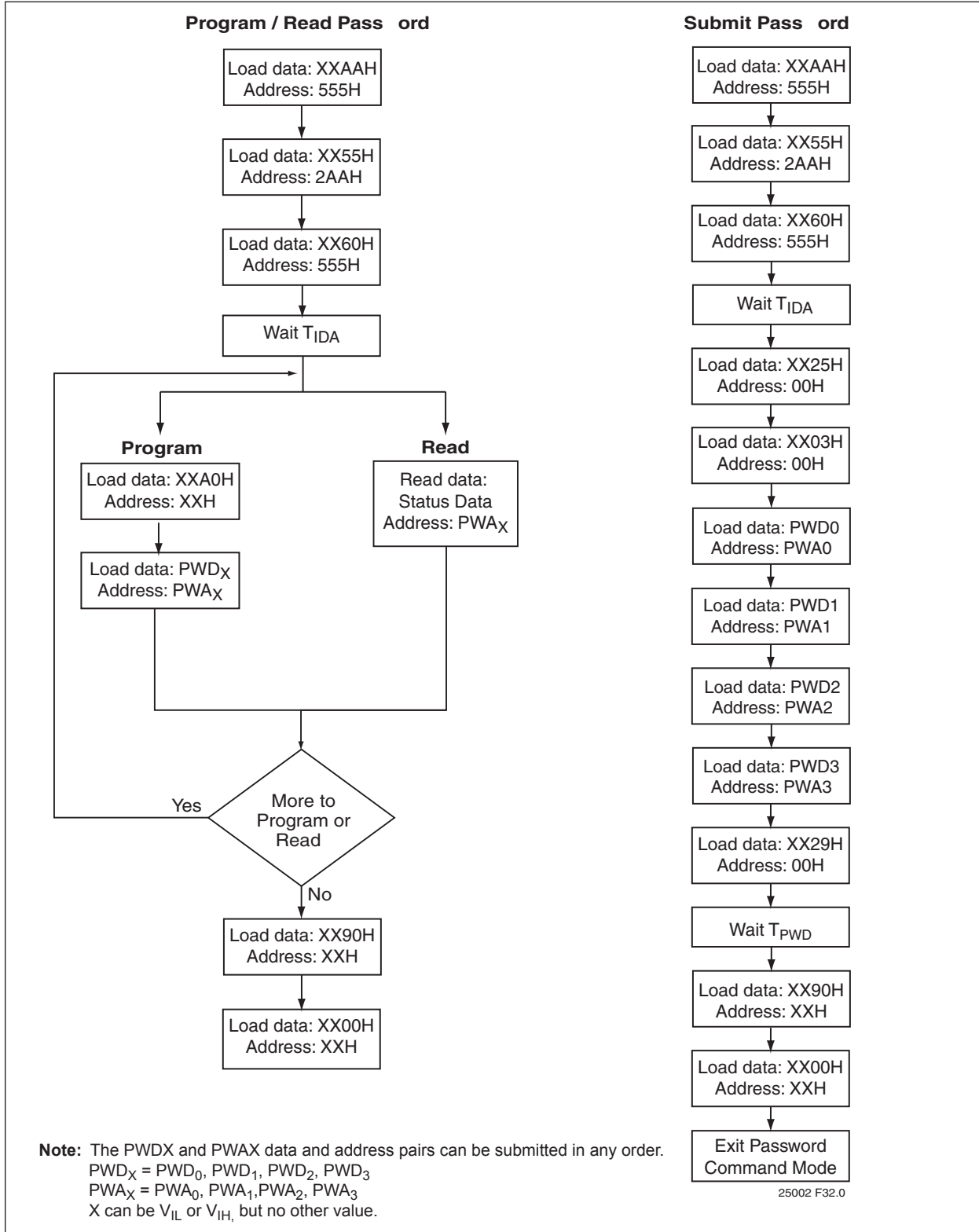

FIGURE 6-30: IRREVERSIBLE BLOCK LOCK IN MAIN ARRAY



7.0 PACKAGING DIAGRAMS

48-LEAD THIN SMALL OUTLINE PACKAGE (TV) - 12x20 mm Body [TSOP]

Note: For the most current package drawings, please see the Microchip Packaging Specification located at <http://www.microchip.com/packaging>



48-LEAD THIN SMALL OUTLINE PACKAGE (TV) - 12x20 mm Body [TSOP]

Note: For the most current package drawings, please see the Microchip Packaging Specification located at <http://www.microchip.com/packaging>



Dimension Limits	Units	MILLIMETERS		
		MIN	NOM	MAX
Number of Pins	N	48		
Pitch	e	0.50 BSC		
Overall Height	A	-	-	1.20
Standoff	A1	0.05	-	0.15
Molded Package Height	A2	0.95	1.00	1.05
Overall Width	E	12.00 BSC		
Overall Length	D	20.00 BSC		
Molded Package Length	D1	18.40 BSC		
Lead Width	b	0.17	0.22	0.27
Lead Thickness	c	0.10	-	0.21
Lead Length	L	0.50	0.60	0.70
Lead Foot Angle	θ	0°	5°	8°

Notes:

- Pin 1 visual index feature may vary, but must be located within the hatched area.
- Dimensioning and tolerancing per ASME Y14.5M
 BSC: Basic Dimension. Theoretically exact value shown without tolerances.
 REF: Reference Dimension, usually without tolerance, for information purposes only.

Microchip Technology Drawing C04-177A Sheet 2 of 2

48-Lead Plastic Thin Fine Pitch Ball Grid Array (CD) - 6x8 mm Body [TFBGA]

Note: For the most current package drawings, please see the Microchip Packaging Specification located at <http://www.microchip.com/packaging>



48-Lead Plastic Thin Fine Pitch Ball Grid Array (CD) - 6x8 mm Body [TFBGA]

Note: For the most current package drawings, please see the Microchip Packaging Specification located at <http://www.microchip.com/packaging>

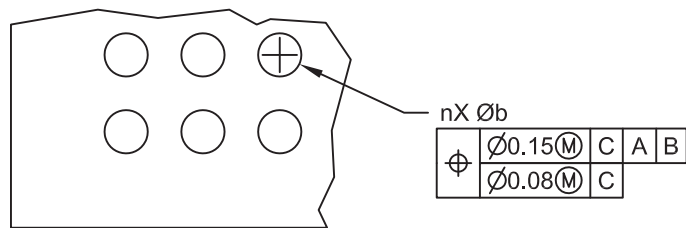

DETAIL B

Dimension	Units	MILLIMETERS		
		MIN	NOM	MAX
Number of Solder Balls	n	48		
Solder Ball X-Pitch	eD	0.80 BSC		
Solder Ball Y-Pitch	eE	0.80 BSC		
Overall Height	A	-	-	1.20
Standoff	A1	0.30	-	-
Molded Package Thickness	A2	-	-	0.95
Overall Width	D	8.00 BSC		
Overall Solder Ball X-Pitch	D1	5.60 BSC		
Overall Length	E	6.00 BSC		
Overall Solder Ball Y-Pitch	E1	4.00 BSC		
Solder Ball Diameter	b	0.40	0.45	0.50

Notes:

- Pin 1 visual index feature may vary, but must be located within the hatched area.
- Dimensioning and tolerancing per ASME Y14.5M
 BSC: Basic Dimension. Theoretically exact value shown without tolerances.
 REF: Reference Dimension, usually without tolerance, for information purposes only.

TABLE 7-1: REVISION HISTORY

Number	Description	Date
A	<ul style="list-style-type: none">• Initial release	Aug 2011
B	<ul style="list-style-type: none">• Applied new document format• Revised Table 5-7 and Table 6-2• Updated “Packaging Diagrams” on page 48• Migrated to new package drawing style	Jan 2013
C	<ul style="list-style-type: none">• Updated part markings in Table 8-1 on page 54• Revised part numbers in “Product Identification System” on page 54	Jul 2013
D	<ul style="list-style-type: none">• Corrected a part number in “Product Identification System” on page 54	Nov 2013

THE MICROCHIP WEB SITE

Microchip provides online support via our WWW site at www.microchip.com. This web site is used as a means to make files and information easily available to customers. Accessible by using your favorite Internet browser, the web site contains the following information:

- **Product Support** – Data sheets and errata, application notes and sample programs, design resources, user's guides and hardware support documents, latest software releases and archived software
- **General Technical Support** – Frequently Asked Questions (FAQ), technical support requests, online discussion groups, Microchip consultant program member listing
- **Business of Microchip** – Product selector and ordering guides, latest Microchip press releases, listing of seminars and events, listings of Microchip sales offices, distributors and factory representatives

CUSTOMER CHANGE NOTIFICATION SERVICE

Microchip's customer notification service helps keep customers current on Microchip products. Subscribers will receive e-mail notification whenever there are changes, updates, revisions or errata related to a specified product family or development tool of interest.

To register, access the Microchip web site at www.microchip.com. Under "Support", click on "Customer Change Notification" and follow the registration instructions.

CUSTOMER SUPPORT

Users of Microchip products can receive assistance through several channels:

- Distributor or Representative
- Local Sales Office
- Field Application Engineer (FAE)
- Technical Support

Customers should contact their distributor, representative or Field Application Engineer (FAE) for support. Local sales offices are also available to help customers. A listing of sales offices and locations is included in the back of this document.

Technical support is available through the web site at: <http://microchip.com/support>

8.0 PRODUCT IDENTIFICATION SYSTEM

To order or obtain information, e.g., on pricing or delivery, refer to the factory or the listed sales office.

PART NO.	XXX	XX	XXX	X	Valid Combinations:
Device	Read Access Speed	Endurance/ Temperature	Package	Tape/Reel Indicator	
Device:	SST38VF6401B	= 64 Mbit, 2.7-3.6V, Advanced Multi-Purpose Flash Plus Bottom Boot-Block Uniform (32 KWord)			SST38VF6401B-70I/TV SST38VF6401BT-70I/TV SST38VF6401B-70I/CD SST38VF6401BT-70I/CD SST38VF6402B-70I/TV SST38VF6402BT-70I/TV SST38VF6402B-70I/CD SST38VF6402BT-70I/CD SST38VF6403B-70I/TV SST38VF6403BT-70I/TV SST38VF6403B-70I/CD SST38VF6403BT-70I/CD SST38VF6404B-70I/TV SST38VF6404BT-70I/TV SST38VF6404B-70I/CD SST38VF6404BT-70I/CD
	SST38VF6402B	= 64 Mbit, 2.7-3.6V, Advanced Multi-Purpose Flash Plus Top Boot-Block Uniform (32 KWord)			
	SST38VF6403B	= 64 Mbit, 2.7-3.6V, Advanced Multi-Purpose Flash Plus Bottom Boot-Block Non- Uniform (8 KWord)			
	SST38VF6404B	= 64 Mbit, 2.7-3.6V, Advanced Multi-Purpose Flash Plus Top Boot-Block Non- Uniform (8 KWord)			
Tape and Reel Flag:	T	= Tape and Reel			
Read Access Speed:	70	= 70 ns			
Temperature:	I	= -40°C to +85°C			
Package:	TV	= TSOP (12mm x 20mm), 48-lead			
	CD	= TFBGA (6mm x 8mm), 48-lead			

TABLE 8-1: PART MARKING

Ordering Number	Marking On Part
SST38VF6401B-70I/TV	38VF6401B-I/TV
SST38VF6401B-70I/CD	38VF6401B-I/CD
SST38VF6402B-70I/TV	38VF6402B-I/TV
SST38VF6402B-70I/CD	38VF6402B-I/CD
SST38VF6403B-70I/TV	38VF6403B-I/TV
SST38VF6403B-70I/CD	38VF6403B-I/CD
SST38VF6404B-70I/TV	38VF6404B-I/TV
SST38VF6404B-70I/CD	38VF6404B-I/CD

Note the following details of the code protection feature on Microchip devices:

- Microchip products meet the specification contained in their particular Microchip Data Sheet.
- Microchip believes that its family of products is one of the most secure families of its kind on the market today, when used in the intended manner and under normal conditions.
- There are dishonest and possibly illegal methods used to breach the code protection feature. All of these methods, to our knowledge, require using the Microchip products in a manner outside the operating specifications contained in Microchip's Data Sheets. Most likely, the person doing so is engaged in theft of intellectual property.
- Microchip is willing to work with the customer who is concerned about the integrity of their code.
- Neither Microchip nor any other semiconductor manufacturer can guarantee the security of their code. Code protection does not mean that we are guaranteeing the product as "unbreakable."

Code protection is constantly evolving. We at Microchip are committed to continuously improving the code protection features of our products. Attempts to break Microchip's code protection feature may be a violation of the Digital Millennium Copyright Act. If such acts allow unauthorized access to your software or other copyrighted work, you may have a right to sue for relief under that Act.

Information contained in this publication regarding device applications and the like is provided only for your convenience and may be superseded by updates. It is your responsibility to ensure that your application meets with your specifications. MICROCHIP MAKES NO REPRESENTATIONS OR WARRANTIES OF ANY KIND WHETHER EXPRESS OR IMPLIED, WRITTEN OR ORAL, STATUTORY OR OTHERWISE, RELATED TO THE INFORMATION, INCLUDING BUT NOT LIMITED TO ITS CONDITION, QUALITY, PERFORMANCE, MERCHANTABILITY OR FITNESS FOR PURPOSE. Microchip disclaims all liability arising from this information and its use. Use of Microchip devices in life support and/or safety applications is entirely at the buyer's risk, and the buyer agrees to defend, indemnify and hold harmless Microchip from any and all damages, claims, suits, or expenses resulting from such use. No licenses are conveyed, implicitly or otherwise, under any Microchip intellectual property rights.

Trademarks

The Microchip name and logo, the Microchip logo, dsPIC, FlashFlex, KEELOQ, KEELOQ logo, MPLAB, PIC, PICmicro, PICSTART, PIC³² logo, rPIC, SST, SST Logo, SuperFlash and UNI/O are registered trademarks of Microchip Technology Incorporated in the U.S.A. and other countries.

FilterLab, Hampshire, HI-TECH C, Linear Active Thermistor, MTP, SEEVAL and The Embedded Control Solutions Company are registered trademarks of Microchip Technology Incorporated in the U.S.A.

Silicon Storage Technology is a registered trademark of Microchip Technology Inc. in other countries.

Analog-for-the-Digital Age, Application Maestro, BodyCom, chipKIT, chipKIT logo, CodeGuard, dsPICDEM, dsPICDEM.net, dsPICworks, dsSPEAK, ECAN, ECONOMONITOR, FanSense, HI-TIDE, In-Circuit Serial Programming, ICSP, Mindi, MiWi, MPASM, MPF, MPLAB Certified logo, MPLIB, MPLINK, mTouch, Omniscient Code Generation, PICC, PICC-18, PICDEM, PICDEM.net, PICkit, PICtail, REAL ICE, rLAB, Select Mode, SQI, Serial Quad I/O, Total Endurance, TSHARC, UniWinDriver, WiperLock, ZENA and Z-Scale are trademarks of Microchip Technology Incorporated in the U.S.A. and other countries.

SQTP is a service mark of Microchip Technology Incorporated in the U.S.A.

GestIC and ULPP are registered trademarks of Microchip Technology Germany II GmbH & Co. & KG, a subsidiary of Microchip Technology Inc., in other countries.

All other trademarks mentioned herein are property of their respective companies.

© 2013, Microchip Technology Incorporated, Printed in the U.S.A., All Rights Reserved.

 Printed on recycled paper.

ISBN:978-1-62077-613-1

QUALITY MANAGEMENT SYSTEM
CERTIFIED BY DNV
== ISO/TS 16949 ==



MICROCHIP

World Wide Sales and Service

AMERICAS

Corporate Office
2355 West Chandler Blvd.
Chandler, AZ 85224-6199
Tel: 480-792-7200
Fax: 480-792-7277
Technical Support:
[http://www.microchip.com/
support](http://www.microchip.com/support)
Web Address:
www.microchip.com

Atlanta

Duluth, GA
Tel: 678-957-9614
Fax: 678-957-1455

Boston

Westborough, MA
Tel: 774-760-0087
Fax: 774-760-0088

Chicago

Itasca, IL
Tel: 630-285-0071
Fax: 630-285-0075

Cleveland

Independence, OH
Tel: 216-447-0464
Fax: 216-447-0643

Dallas

Addison, TX
Tel: 972-818-7423
Fax: 972-818-2924

Detroit

Farmington Hills, MI
Tel: 248-538-2250
Fax: 248-538-2260

Indianapolis

Noblesville, IN
Tel: 317-773-8323
Fax: 317-773-5453

Los Angeles

Mission Viejo, CA
Tel: 949-462-9523
Fax: 949-462-9608

Santa Clara

Santa Clara, CA
Tel: 408-961-6444
Fax: 408-961-6445

Toronto

Mississauga, Ontario,
Canada
Tel: 905-673-0699
Fax: 905-673-6509

ASIA/PACIFIC

Asia Pacific Office
Suites 3707-14, 37th Floor
Tower 6, The Gateway
Harbour City, Kowloon
Hong Kong
Tel: 852-2401-1200
Fax: 852-2401-3431

Australia - Sydney

Tel: 61-2-9868-6733
Fax: 61-2-9868-6755

China - Beijing

Tel: 86-10-8569-7000
Fax: 86-10-8528-2104

China - Chengdu

Tel: 86-28-8665-5511
Fax: 86-28-8665-7889

China - Chongqing

Tel: 86-23-8980-9588
Fax: 86-23-8980-9500

China - Hangzhou

Tel: 86-571-2819-3187
Fax: 86-571-2819-3189

China - Hong Kong SAR

Tel: 852-2943-5100
Fax: 852-2401-3431

China - Nanjing

Tel: 86-25-8473-2460
Fax: 86-25-8473-2470

China - Qingdao

Tel: 86-532-8502-7355
Fax: 86-532-8502-7205

China - Shanghai

Tel: 86-21-5407-5533
Fax: 86-21-5407-5066

China - Shenyang

Tel: 86-24-2334-2829
Fax: 86-24-2334-2393

China - Shenzhen

Tel: 86-755-8864-2200
Fax: 86-755-8203-1760

China - Wuhan

Tel: 86-27-5980-5300
Fax: 86-27-5980-5118

China - Xian

Tel: 86-29-8833-7252
Fax: 86-29-8833-7256

China - Xiamen

Tel: 86-592-2388138
Fax: 86-592-2388130

China - Zhuhai

Tel: 86-756-3210040
Fax: 86-756-3210049

ASIA/PACIFIC

India - Bangalore
Tel: 91-80-3090-4444
Fax: 91-80-3090-4123

India - New Delhi

Tel: 91-11-4160-8631
Fax: 91-11-4160-8632

India - Pune

Tel: 91-20-3019-1500

Japan - Osaka

Tel: 81-6-6152-7160
Fax: 81-6-6152-9310

Japan - Tokyo

Tel: 81-3-6880-3770
Fax: 81-3-6880-3771

Korea - Daegu

Tel: 82-53-744-4301
Fax: 82-53-744-4302

Korea - Seoul

Tel: 82-2-554-7200
Fax: 82-2-558-5932 or
82-2-558-5934

Malaysia - Kuala Lumpur

Tel: 60-3-6201-9857
Fax: 60-3-6201-9859

Malaysia - Penang

Tel: 60-4-227-8870
Fax: 60-4-227-4068

Philippines - Manila

Tel: 63-2-634-9065
Fax: 63-2-634-9069

Singapore

Tel: 65-6334-8870
Fax: 65-6334-8850

Taiwan - Hsin Chu

Tel: 886-3-5778-366
Fax: 886-3-5770-955

Taiwan - Kaohsiung

Tel: 886-7-213-7828
Fax: 886-7-330-9305

Taiwan - Taipei

Tel: 886-2-2508-8600
Fax: 886-2-2508-0102

Thailand - Bangkok

Tel: 66-2-694-1351
Fax: 66-2-694-1350

EUROPE

Austria - Wels
Tel: 43-7242-2244-39
Fax: 43-7242-2244-393

Denmark - Copenhagen

Tel: 45-4450-2828
Fax: 45-4485-2829

France - Paris

Tel: 33-1-69-53-63-20
Fax: 33-1-69-30-90-79

Germany - Munich

Tel: 49-89-627-144-0
Fax: 49-89-627-144-44

Italy - Milan

Tel: 39-0331-742611
Fax: 39-0331-466781

Netherlands - Drunen

Tel: 31-416-690399
Fax: 31-416-690340

Spain - Madrid

Tel: 34-91-708-08-90
Fax: 34-91-708-08-91

UK - Wokingham

Tel: 44-118-921-5869
Fax: 44-118-921-5820

Компания «Океан Электроники» предлагает заключение долгосрочных отношений при поставках импортных электронных компонентов на взаимовыгодных условиях!

Наши преимущества:

- Поставка оригинальных импортных электронных компонентов напрямую с производств Америки, Европы и Азии, а так же с крупнейших складов мира;
- Широкая линейка поставок активных и пассивных импортных электронных компонентов (более 30 млн. наименований);
- Поставка сложных, дефицитных, либо снятых с производства позиций;
- Оперативные сроки поставки под заказ (от 5 рабочих дней);
- Экспресс доставка в любую точку России;
- Помощь Конструкторского Отдела и консультации квалифицированных инженеров;
- Техническая поддержка проекта, помощь в подборе аналогов, поставка прототипов;
- Поставка электронных компонентов под контролем ВП;
- Система менеджмента качества сертифицирована по Международному стандарту ISO 9001;
- При необходимости вся продукция военного и аэрокосмического назначения проходит испытания и сертификацию в лаборатории (по согласованию с заказчиком);
- Поставка специализированных компонентов военного и аэрокосмического уровня качества (Xilinx, Altera, Analog Devices, Intersil, Interpoint, Microsemi, Actel, Aeroflex, Peregrine, VPT, Syfer, Eurofarad, Texas Instruments, MS Kennedy, Miteq, Cobham, E2V, MA-COM, Hittite, Mini-Circuits, General Dynamics и др.);

Компания «Океан Электроники» является официальным дистрибьютором и эксклюзивным представителем в России одного из крупнейших производителей разъемов военного и аэрокосмического назначения «JONHON», а так же официальным дистрибьютором и эксклюзивным представителем в России производителя высокотехнологичных и надежных решений для передачи СВЧ сигналов «FORSTAR».



JONHON

«JONHON» (основан в 1970 г.)

Разъемы специального, военного и аэрокосмического назначения:

(Применяются в военной, авиационной, аэрокосмической, морской, железнодорожной, горно- и нефтедобывающей отраслях промышленности)

«FORSTAR» (основан в 1998 г.)

ВЧ соединители, коаксиальные кабели,
кабельные сборки и микроволновые компоненты:

(Применяются в телекоммуникациях гражданского и специального назначения, в средствах связи, РЛС, а так же военной, авиационной и аэрокосмической отраслях промышленности).



Телефон: 8 (812) 309-75-97 (многоканальный)

Факс: 8 (812) 320-03-32

Электронная почта: ocean@oceanchips.ru

Web: <http://oceanchips.ru/>

Адрес: 198099, г. Санкт-Петербург, ул. Калинина, д. 2, корп. 4, лит. А