

EFC2J004NUZ

Power MOSFET for 1-Cell Lithium-ion Battery Protection 12 V, 7.1 mΩ, 14 A, Dual N-Channel



ON Semiconductor®

www.onsemi.com

This Power MOSFET features a low on-state resistance. This device is suitable for applications such as power switches of portable machines. Best suited for 1-cell lithium-ion battery applications.

Features

- 2.5 V Drive
- 2 kV ESD HBM
- Common-Drain Type
- ESD Diode-Protected Gate
- Pb-Free, Halogen Free and RoHS compliance

Applications

- 1-Cell Lithium-ion Battery Charging and Discharging Switch

SPECIFICATIONS

ABSOLUTE MAXIMUM RATINGS at Ta = 25°C (Notes 1, 2)

Parameter	Symbol	Value	Unit
Source to Source Voltage	V _{SSS}	12	V
Gate to Source Voltage	V _{GSS}	±8	V
Source Current (DC)	I _S	14	A
Source Current (Pulse) PW ≤ 10μs, duty cycle ≤ 1%	I _{SP}	60	A
Total Dissipation (Note 2)	P _T	1.5	W
Junction Temperature	T _J	150	°C
Storage Temperature	T _{stg}	-55 to +150	°C

Note 1 : Stresses exceeding those listed in the Maximum Ratings table may damage the device. If any of these limits are exceeded, device functionality should not be assumed, damage may occur and reliability may be affected.

THERMAL RESISTANCE RATINGS

Parameter	Symbol	Value	Unit
Junction to Ambient (Note 2)	R _{θJA}	83	°C/W

Note 2 : Surface mounted on ceramic substrate (5000 mm² × 0.8 mm).

V _{SSS}	R _{SS(on)} Max	I _S Max
12 V	7.1 mΩ @ 4.5 V	14 A
	7.7 mΩ @ 3.8 V	
	9.5 mΩ @ 3.1 V	
	12.4mΩ @ 2.5 V	

ELECTRICAL CONNECTION N-Channel

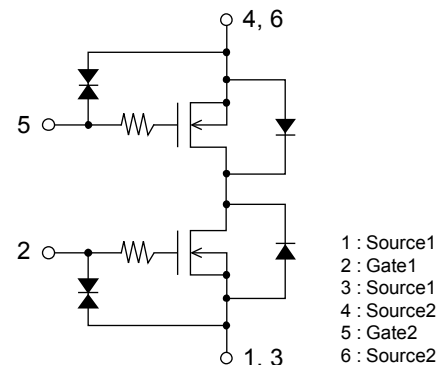

WLCSP6, 2.11x1.18x0.10

GENERIC MARKING DIAGRAM

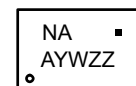

NA = Specific Device Code
A = Assembly Location
Y = Year
W = Work Week
ZZ = Assembly Lot
▪ = Pb-Free Package

ORDERING INFORMATION

See detailed ordering and shipping information on page 6 of this data sheet.

EFC2J004NUZ

ELECTRICAL CHARACTERISTICS at Ta = 25°C (Notes 3, 4)

Parameter	Symbol	Conditions	Value			Unit
			min	typ	max	
Source to Source Breakdown Voltage	V(BR)SSS	IS = 1 mA, VGS = 0 V Test Circuit 1	12			V
Zero-Gate Voltage Source Current	ISSS	VSS = 10 V, VGS = 0 V Test Circuit 1			1	μA
Gate to Source Leakage Current	IGSS	VGS = ±8 V, VSS = 0 V Test Circuit 2			±1	μA
Gate Threshold Voltage	VGS(th)	VSS = 6 V, IS = 1 mA Test Circuit 3	0.4		1.3	V
Static Source to Source On-State Resistance (Note 4)	RSS(on)	IS = 5 A, VGS = 4.5 V Test Circuit 4	3.7	5.4	7.1	mΩ
		IS = 5 A, VGS = 3.8 V Test Circuit 4	4.1	5.9	7.7	mΩ
		IS = 5 A, VGS = 3.1 V Test Circuit 4	4.6	6.7	9.5	mΩ
		IS = 5 A, VGS = 2.5 V Test Circuit 4	5.8	8.4	12.4	mΩ
Turn-ON Delay Time	td(on)	VSS = 5 V, VGS = 3.8 V, IS = 5 A Rg = 10 kΩ Test Circuit 5		15		μs
Rise Time	tr			35		μs
Turn-OFF Delay Time	td(off)			100		μs
Fall Time	tf			75		μs
Total Gate Charge	Qg		VSS = 6 V, VGS = 4.5 V, IS = 14 A Test Circuit 6		36	
Forward Source to Source Voltage	VF(S-S)	IS = 3 A, VGS = 0 V Test Circuit 7		0.76		V

Note 3 : Product parametric performance is indicated in the Electrical Characteristics for the listed test conditions, unless otherwise noted. Product performance may not be indicated by the Electrical Characteristics if operated under different conditions.

Note 4 : Mounted on ON Semiconductor board.

Test circuits are example of measuring FET1 side

Test Circuit 1
 $V_{(BR)SSS} / I_{SSS}$

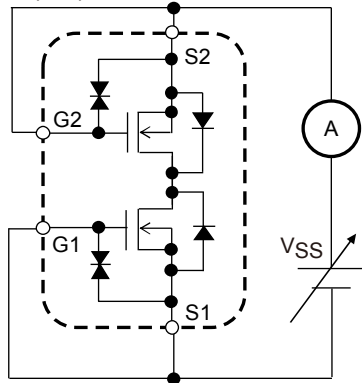

Test Circuit 2
 I_{GSS}

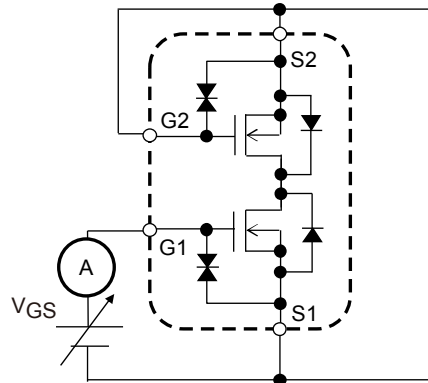

When FET1 is measured, Gate and Source of FET2 are short-circuited.

Test Circuit 3
 $V_{GS(th)}$

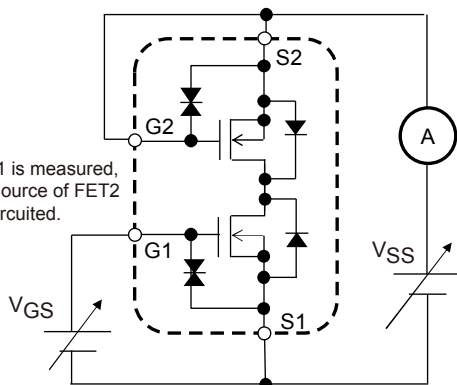

When FET1 is measured, Gate and Source of FET2 are short-circuited.

Test Circuit 4
 $R_{SS(on)}$

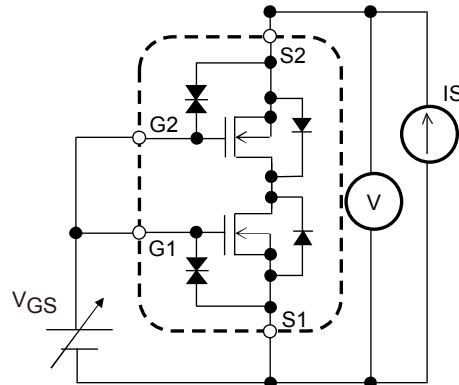

Test Circuit 5
 $t_{d(on)}, t_r, t_d(off), t_f$

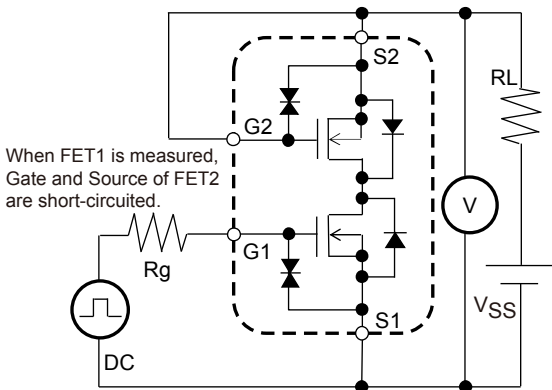

When FET1 is measured, Gate and Source of FET2 are short-circuited.

Test Circuit 6
 Q_g

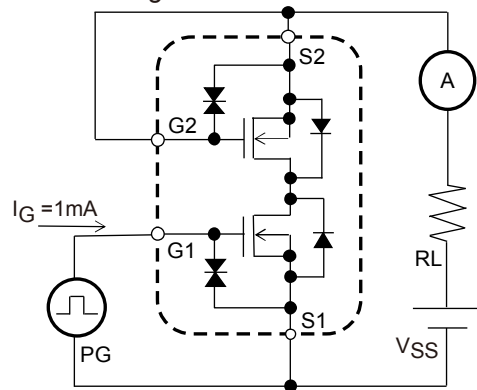

When FET1 is measured, Gate and Source of FET2 are short-circuited.

Test Circuit 7
 $V_{F(S-S)}$

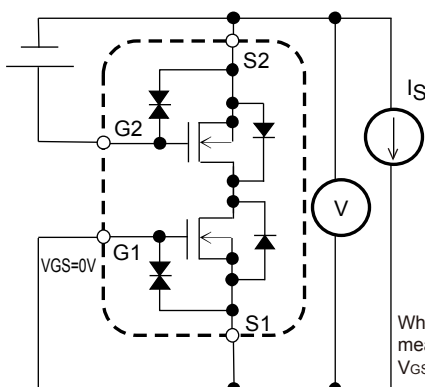

When FET1 is measured, +4.5V is added to V_{GS} of FET2.

When FET2 is measured, the position of FET1 and FET2 is switched.

EFC2J004NUZ

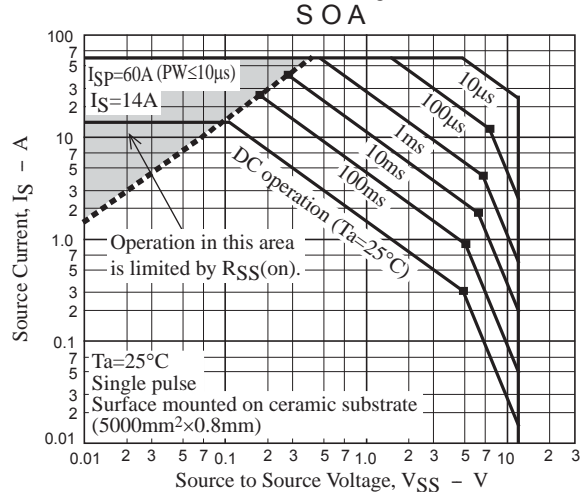
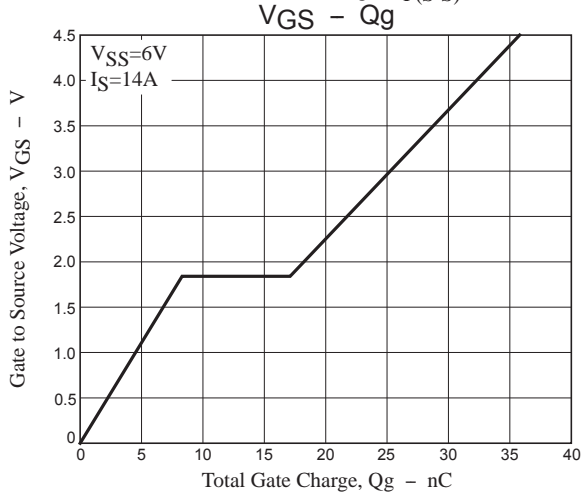
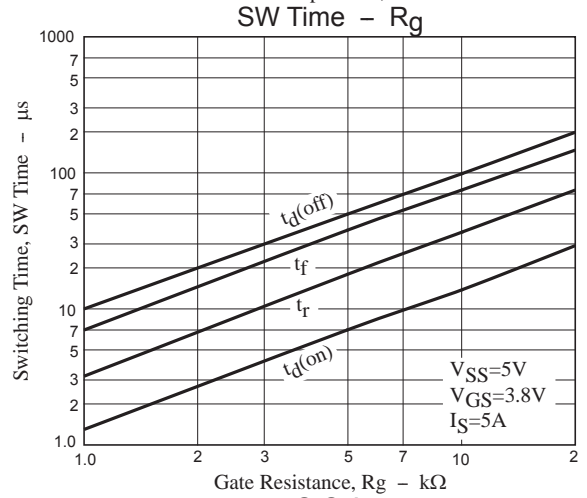
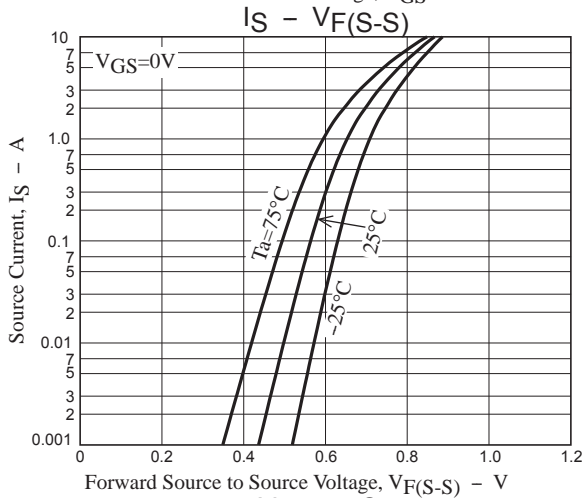
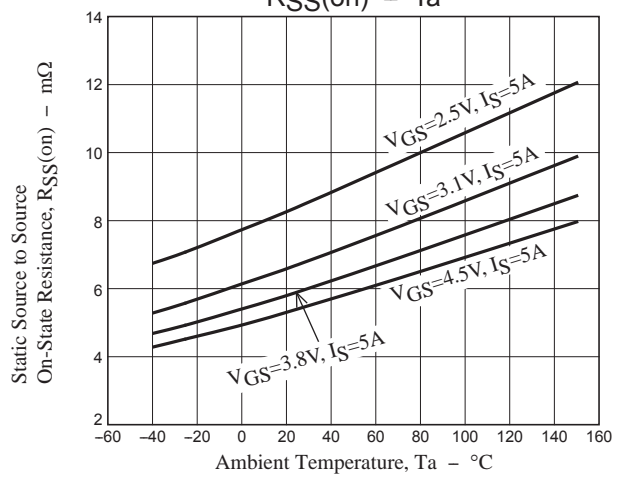
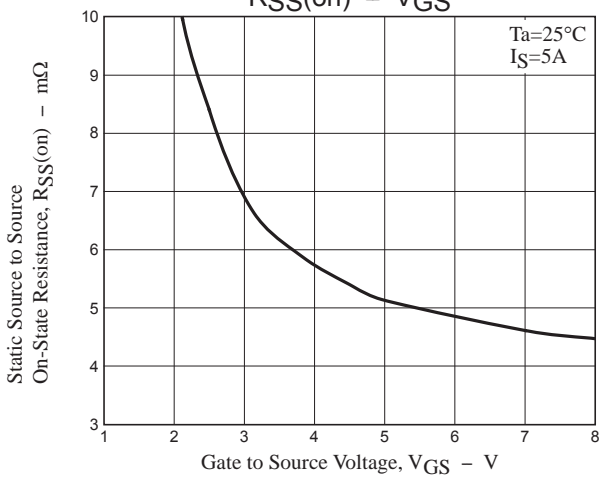
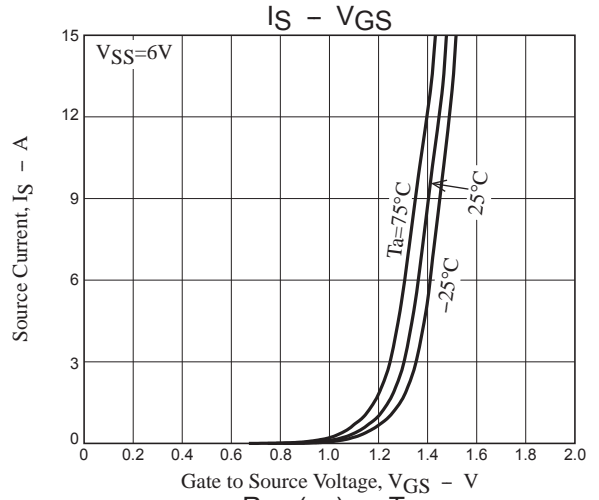
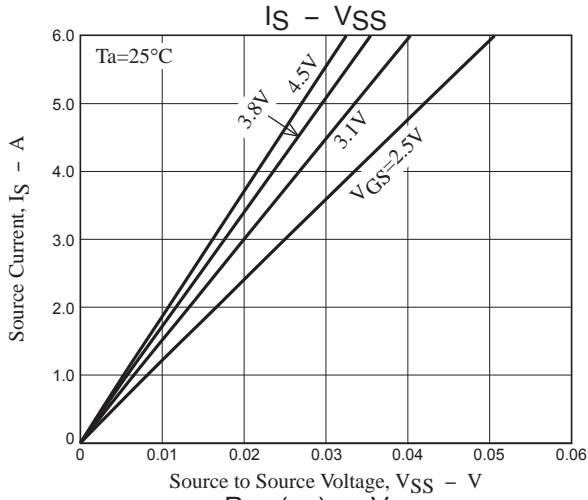

EFC2J004NUZ

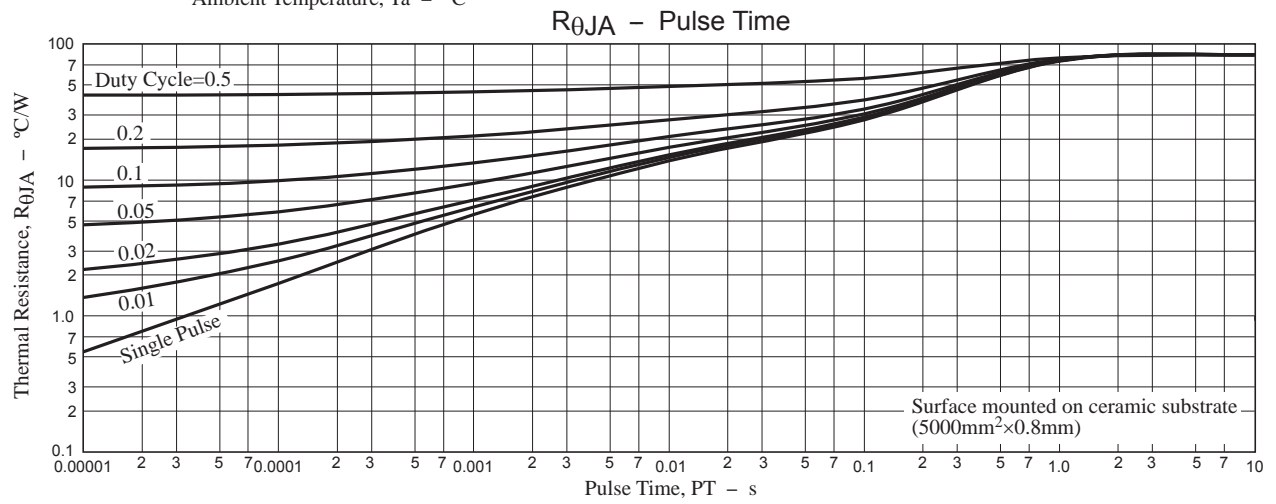
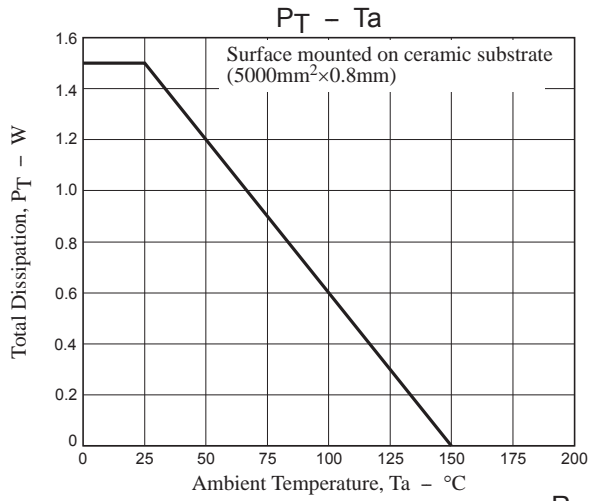

EFC2J004NUZ

PACKAGE DIMENSIONS

unit : mm

WLCSP6, 2.11x1.18x0.10

CASE 567NP

ISSUE B

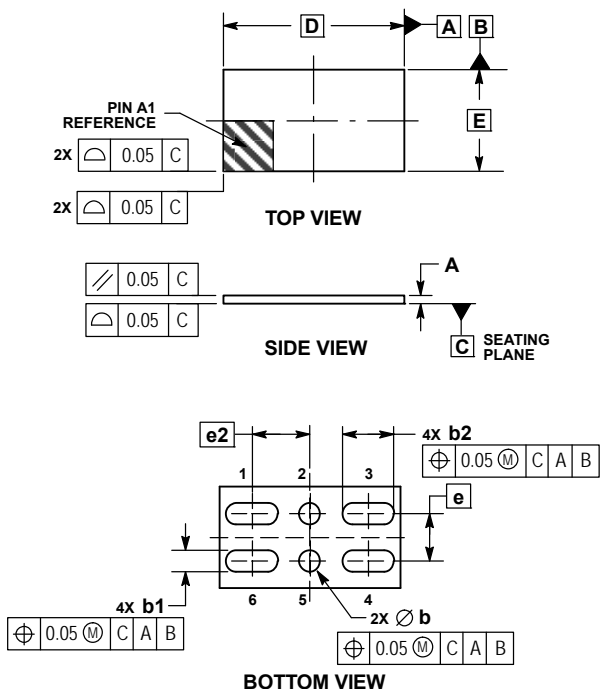

- 1 : Source1
- 2 : Gate1
- 3 : Source1
- 4 : Source2
- 5 : Gate2
- 6 : Source2

- NOTES:
1. DIMENSIONING AND TOLERANCING PER ASME Y14.5M, 1994.
 2. CONTROLLING DIMENSION: MILLIMETERS.

DIM	MILLIMETERS		
	MIN	NOM	MAX
A	0.08	0.10	0.12
b	0.22	0.25	0.28
b1	0.27	0.30	0.33
b2	0.575	0.605	0.635
D	2.11 BSC		
E	1.18 BSC		
e	0.55 BSC		
e2	0.6775 BSC		

RECOMMENDED SOLDERING FOOTPRINT*

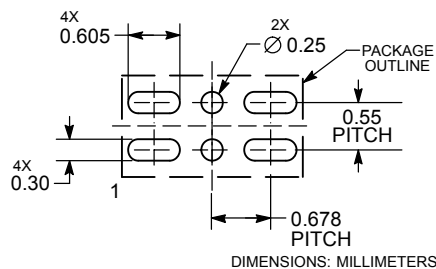

*For additional information on our Pb-Free strategy and soldering details, please download the ON Semiconductor Soldering and Mounting Techniques Reference Manual, SOLDERRM/D.

ORDERING INFORMATION

Device	Marking	Package	Shipping (Qty / Packing)
EFC2J004NUZTDG	NA	WLCSP6, 2.11x1.18x0.10 (Pb-Free / Halogen Free)	5,000 / Tape & Reel

† For information on tape and reel specifications, including part orientation and tape sizes, please refer to our Tape and Reel Packaging Specifications Brochure, BRD8011/D. http://www.onsemi.com/pub_link/Collateral/BRD8011-D.PDF

Note on usage : Since the EFC2J004NUZ is a MOSFET product, please avoid using this device in the vicinity of highly charged objects. Please contact sales for use except the designated application.

ON Semiconductor and the ON Semiconductor logo are trademarks of Semiconductor Components Industries, LLC dba ON Semiconductor or its subsidiaries in the United States and/or other countries. ON Semiconductor owns the rights to a number of patents, trademarks, copyrights, trade secrets, and other intellectual property. A listing of ON Semiconductor's product/patent coverage may be accessed at www.onsemi.com/site/pdf/Patent-Marking.pdf. ON Semiconductor reserves the right to make changes without further notice to any products herein. ON Semiconductor makes no warranty, representation or guarantee regarding the suitability of its products for any particular purpose, nor does ON Semiconductor assume any liability arising out of the application or use of any product or circuit, and specifically disclaims any and all liability, including without limitation special, consequential or incidental damages. Buyer is responsible for its products and applications using ON Semiconductor products, including compliance with all laws, regulations and safety requirements or standards, regardless of any support or applications information provided by ON Semiconductor. "Typical" parameters which may be provided in ON Semiconductor data sheets and/or specifications can and do vary in different applications and actual performance may vary over time. All operating parameters, including "Typicals" must be validated for each customer application by customer's technical experts. ON Semiconductor does not convey any license under its patent rights nor the rights of others. ON Semiconductor products are not designed, intended, or authorized for use as a critical component in life support systems or any FDA Class 3 medical devices or medical devices with a same or similar classification in a foreign jurisdiction or any devices intended for implantation in the human body. Should Buyer purchase or use ON Semiconductor products for any such unintended or unauthorized application, Buyer shall indemnify and hold ON Semiconductor and its officers, employees, subsidiaries, affiliates, and distributors harmless against all claims, costs, damages, and expenses, and reasonable attorney fees arising out of, directly or indirectly, any claim of personal injury or death associated with such unintended or unauthorized use, even if such claim alleges that ON Semiconductor was negligent regarding the design or manufacture of the part. ON Semiconductor is an Equal Opportunity/Affirmative Action Employer. This literature is subject to all applicable copyright laws and is not for resale in any manner.

Компания «Океан Электроники» предлагает заключение долгосрочных отношений при поставках импортных электронных компонентов на взаимовыгодных условиях!

Наши преимущества:

- Поставка оригинальных импортных электронных компонентов напрямую с производств Америки, Европы и Азии, а так же с крупнейших складов мира;
- Широкая линейка поставок активных и пассивных импортных электронных компонентов (более 30 млн. наименований);
- Поставка сложных, дефицитных, либо снятых с производства позиций;
- Оперативные сроки поставки под заказ (от 5 рабочих дней);
- Экспресс доставка в любую точку России;
- Помощь Конструкторского Отдела и консультации квалифицированных инженеров;
- Техническая поддержка проекта, помощь в подборе аналогов, поставка прототипов;
- Поставка электронных компонентов под контролем ВП;
- Система менеджмента качества сертифицирована по Международному стандарту ISO 9001;
- При необходимости вся продукция военного и аэрокосмического назначения проходит испытания и сертификацию в лаборатории (по согласованию с заказчиком);
- Поставка специализированных компонентов военного и аэрокосмического уровня качества (Xilinx, Altera, Analog Devices, Intersil, Interpoint, Microsemi, Actel, Aeroflex, Peregrine, VPT, Syfer, Eurofarad, Texas Instruments, MS Kennedy, Miteq, Cobham, E2V, MA-COM, Hittite, Mini-Circuits, General Dynamics и др.);

Компания «Океан Электроники» является официальным дистрибьютором и эксклюзивным представителем в России одного из крупнейших производителей разъемов военного и аэрокосмического назначения «JONHON», а так же официальным дистрибьютором и эксклюзивным представителем в России производителя высокотехнологичных и надежных решений для передачи СВЧ сигналов «FORSTAR».



JONHON

«JONHON» (основан в 1970 г.)

Разъемы специального, военного и аэрокосмического назначения:

(Применяются в военной, авиационной, аэрокосмической, морской, железнодорожной, горно- и нефтедобывающей отраслях промышленности)

«FORSTAR» (основан в 1998 г.)

ВЧ соединители, коаксиальные кабели, кабельные сборки и микроволновые компоненты:

(Применяются в телекоммуникациях гражданского и специального назначения, в средствах связи, РЛС, а так же военной, авиационной и аэрокосмической отраслях промышленности).



Телефон: 8 (812) 309-75-97 (многоканальный)

Факс: 8 (812) 320-03-32

Электронная почта: ocean@oceanchips.ru

Web: <http://oceanchips.ru/>

Адрес: 198099, г. Санкт-Петербург, ул. Калинина, д. 2, корп. 4, лит. А