



A New Direction in Mixed-Signal

January 2014

Rev. 1.0.1

# XRP9710 and XRP9711

## Dual 6A Programmable Power Module

### GENERAL DESCRIPTION

The XRP9710 and XRP9711 are programmable step down power modules providing two 6A outputs. The module package contains the switching controller, power MOSFETs, inductors and support components. As a result, external components are minimal. A wide input voltage range (4.75V to 5.5V or 5.5V to 22V) allows for single supply operation from standard power rails.

The modules measure only 12x12x2.75mm making it half the size of competing 12V capable 6Amp modules. The 2.75mm height allows them to be placed on the back of boards or under heat sinks where other solutions cannot, yet they contain two full 6A buck power stages and two Digital Pulse Width Modulator (DPWM) controllers with gate drivers. Designed to operate at a constant PWM switching frequency between 500kHz and 750kHz, the Digital Pulse Frequency Mode (DPFM) results in better than 80% efficiency at light load currents and low operating current allow for portable and Energy Star compliant applications. Each XRP9710 or XRP9711 output can be individually programmed to as low as 0.6V with a resolution as fine as 2.5mV, and configurable for precise soft start and soft stop sequencing, including delay and ramp control.

The XRP9710/1 is fully controlled via a SMBus-compliant I<sup>2</sup>C interface allowing for advanced local and/or remote reconfiguration, full performance monitoring and reporting as well as fault handling.

Built-in output over-voltage, over-temperature, over-current and under voltage lockout protections insure safe operation under abnormal operating conditions.

The XRP9710/1 is offered in a RoHS compliant, halogen-free LGA package.

### FEATURES

- **XRP9710 – Dual 6A Outputs with Differential Sensing**
- **XRP9711 – Dual 6A Outputs with Control for Two External Power Stages**
- **12 x 12 x 2.75mm LGA Package**
- **Wide Input Voltage Range: 4.75V to 22V**
  - Low Range: 4.75V to 5.5V
  - High Range: 5.5V-22V
- **Output Voltage Range: 0.6V to 5.5V**
- **SMBus Compliant - I<sup>2</sup>C Interface**
  - Full Power Monitoring and Reporting
- **3 x 15V Capable PSIOs + 2 x GPIOs**
- **Full Start/Stop Sequencing Support**
- **Built-in Thermal, Over-Current, UVLO and Output Over-Voltage Protections**
- **On-Board 5V Standby LDO**
- **On-Board Non-volatile Memory**
- **CISPR22 Level B radiated emissions**
- **PowerArchitect™ 5.1 or later Design Tool**

### APPLICATIONS

- **Servers**
- **Base Stations**
- **Switches/Routers**
- **Broadcast Equipment**
- **Industrial Control Systems**
- **Automatic Test Equipment**
- **Video Surveillance Systems**



A New Direction in Mixed-Signal

January 2014

# XRP9710 and XRP9711

## Dual 6A Programmable Power Module

Rev. 1.0.1

### TYPICAL APPLICATION DIAGRAM

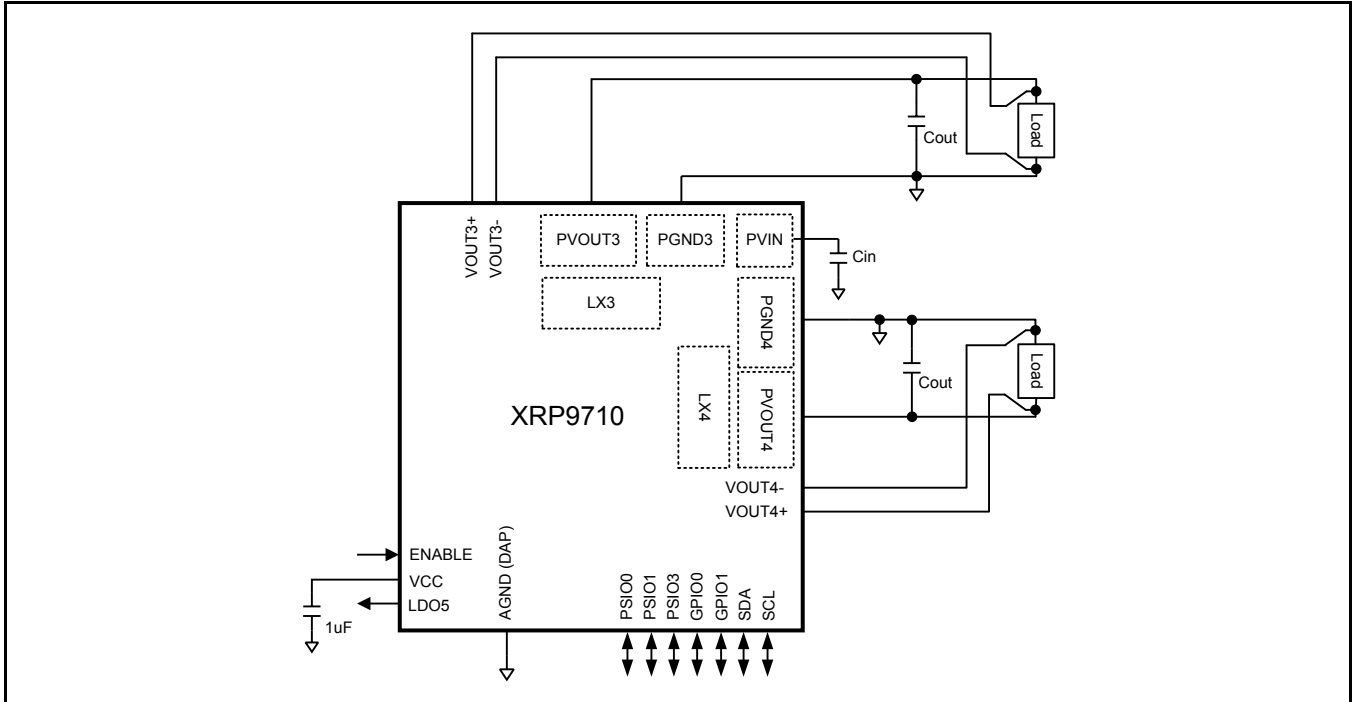

Figure 1 XRP9710 Application Diagram with differential voltage sensing

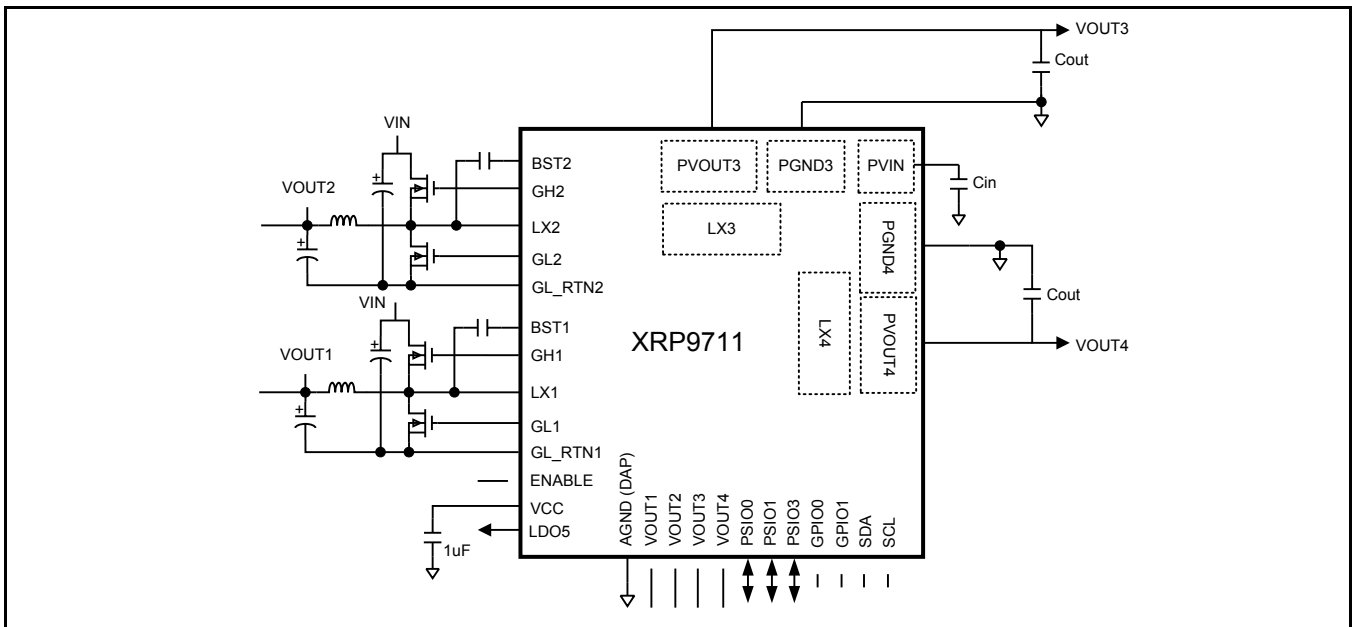

Figure 2 XRP9711 Application Diagram



A New Direction in Mixed-Signal

# XRP9710 and XRP9711

## Dual 6A Programmable Power Module

### FEATURES AND BENEFITS

**World's smallest 12V capable dual 6A module at 12x12x2.75mm**

#### Programmable Power Benefits

- **Fully Configurable**
  - Output set point
  - Feedback compensation
  - Frequency set point
  - Under voltage lock out
  - Input voltage measurement
  - Gate drive dead time
- **Reduced Development Time**
  - Configurable and re-configurable for different Vout, Iout, Cout, and Inductor values
  - No need to change external passives for a new output specification.
- **Higher integration and Reliability**
  - Lowest component count for a fully configurable module

#### PowerArchitect™ 5 Design and Configuration Software

- Wizard quickly generates a base design
- Calculates all configuration registers
- Projects can be saved and/or recalled
- GPIOs can be configured easily and intuitively
- "Dashboard" Interface can be used for real-time monitoring and debug

#### System Benefits

- Reliability is enhanced via communication with the system controller which can obtain real-time data on an output voltage, input voltage and current.
- System processors can communicate with the XRP9710/1 directly to obtain data or make adjustments to react to circuit conditions
- System logging and history, diagnostics and remote reconfigurability.

### System Integration Capabilities

- **Single supply operation**
- **I<sup>2</sup>C interface allows:**
  - Communication with a System Controller or other Power Management devices for optimized system functionality
  - Access to modify or read internal registers that control or monitor:
    - Output Current
    - Input and Output Voltage
    - Soft-Start/Soft-Stop Time
    - 'Power Good'
    - Part Temperature
    - Enable/Disable Outputs
    - Over Current
    - Over Voltage
    - Temperature Faults
    - Adjusting fault limits and disabling/enabling faults
  - Packet Error Checking (PEC) on I<sup>2</sup>C communication
- **5 GPIO pins with a wide range of configurability**
  - Fault reporting (including UVLO Warn/Fault, OCP Warn/Fault, OVP, Temperature, Soft-Start in progress, Power Good, System Reset)
  - Allows a Logic Level interface with other non-digital IC's or as logic inputs to other devices
- **Frequency and Synchronization Capability**
  - Selectable switching frequency between 124kHz and 1.23MHz (500kHz to 750kHz internal power stages)
  - Main oscillator clock and DPWM clock can be synchronized to external sources
- **Internal MOSFET Drivers (XRP9711)**
  - Internal FET drivers (4Ω/2Ω) per channel
  - Built-In Automatic Dead-time adjustment
  - 17ns Rise and 11ns Fall times



### ABSOLUTE MAXIMUM RATINGS

These are stress ratings only and functional operation of the device at these ratings or any other above those indicated in the operation sections of the specifications below is not implied. Exposure to absolute maximum rating conditions for extended periods of time may affect reliability.

|  |                       |
|--|-----------------------|
| LDO5, GLx, VOUTx .....                     | -0.3V to 7.0V         |
| ENABLE.....                                | -0.3V to 7.0V         |
| GPIO0/1, SCL, SDA .....                    | 6.0V                  |
| PSIO Inputs.....                           | 18V                   |
| V <sub>CC</sub> .....                      | 28V                   |
| LXx.....                                   | -1V to 28V            |
| BSTx, GHx.....                             | V <sub>LXx</sub> + 6V |
| Storage Temperature.....                   | -65°C to 150°C        |
| Power Dissipation .....                    | Internally Limited    |
| Lead Temperature (Soldering, 10 sec) ..... | 245°C                 |
| ESD Rating (HBM - Human Body Model).....   | 2kV                   |

### OPERATING RATINGS

|   |                |
|---|----------------|
| Input Voltage Range V <sub>CC</sub> .....                 | 5.5V to 25V    |
| PVIN Voltage Range .....                                  | 3.0 to 22V     |
| Input Voltage Range V <sub>CC</sub> = LDO5 .....          | 4.75V to 5.5V  |
| VOUT1, 2, 3, 4 .....                                      | 5.5V           |
| Junction Temperature Range .....                          | -40°C to 125°C |
| Package Power Dissipation max at 25°C .....               | 5.5W           |
| JEDEC51-2A Package Thermal Resistance $\theta_{JA}$ ..... | 18°C/W         |
| Complies with CISPR22.....                                | Level B        |

### ELECTRICAL SPECIFICATIONS

Specifications with standard type are for an Operating Junction Temperature of T<sub>J</sub> = 25°C only; limits applying over the full Operating Junction Temperature range are denoted by a “•”. Typical values represent the most likely parametric norm at T<sub>J</sub> = 25°C, and are provided for reference purposes only. Unless otherwise indicated, V<sub>CC</sub> = 5.5V to 22V.

### QUIESCENT CURRENT

| Parameter                                  | Min. | Typ. | Max. | Units | Conditions  |
|--|------|------|------|-------|---|
| V <sub>CC</sub> Supply Current in SHUTDOWN |      | 10   | 20   | μA    | EN = 0V, V <sub>CC</sub> = 12V  |
| ENABLE Turn On Threshold                   | 0.82 |      | 0.95 | V     | V <sub>CC</sub> = 12V Enable Rising   |
| ENABLE Pin Leakage Current                 |      |      | 10   | uA    | EN=5V   |
|  | -10  |      |      |       | EN=0V   |
| V <sub>CC</sub> Supply Current in STANDBY  |      | 440  | 600  | μA    | All channels disabled<br>GPIOs programmed as inputs<br>V <sub>CC</sub> =12V, EN = 5V  |
| V <sub>CC</sub> Supply Current 2ch PFM     |      | 3.1  |      | mA    | 2 channels on set at 5V, VOUT forced to 5.1V, no load, non-switching, Ultra-sonic off, V <sub>CC</sub> =12 V, No I <sup>2</sup> C activity. |
| V <sub>CC</sub> Supply Current 4ch PFM     |      | 4.0  |      | mA    | 4 channels on set at 5V, VOUT forced to 5.1V, no load, non-switching, Ultra-sonic off, V <sub>CC</sub> =12V, No I <sup>2</sup> C activity.  |
| V <sub>CC</sub> Supply Current ON          |      | 18   |      | mA    | All channels enabled, F <sub>sw</sub> =600kHz, gate drivers unloaded, No I <sup>2</sup> C activity.   |

### INPUT VOLTAGE RANGE AND UNDERVOLTAGE LOCKOUT

| Parameter             | Min. | Typ. | Max. | Units | Conditions                               |
|-----------------------|------|------|------|-------|--|
| V <sub>CC</sub> Range | 5.5  |      | 25   | V     | •  |
|                       | 4.75 |      | 5.5  | V     | • With V <sub>CC</sub> connected to LDO5 |
| PVIN Range            | 3.0  |      | 22   | V     | •  |



A New Direction in Mixed-Signal

# XRP9710 and XRP9711

## Dual 6A Programmable Power Module

### VOLTAGE FEEDBACK ACCURACY AND OUTPUT VOLTAGE SET POINT RESOLUTION

| Parameter  | Min.                       | Typ.             | Max.                   | Units                | Conditions  |
|--|----------------------------|------------------|------------------------|----------------------|---|
| VOUT Regulation Accuracy<br>Low Output Range<br>0.6V to 1.6V<br>PWM Operation  | -5<br>-20<br>-7.5<br>-22.5 |                  | 5<br>20<br>7.5<br>22.5 | mV<br>mV<br>mV<br>mV | •<br>•<br>•<br>•<br>$0.6 \leq V_{OUT} \leq 1.6V$<br>$V_{CC}=LDO5$                                 |
| VOUT Regulation Accuracy<br>Mid Output Range<br>0.6V to 3.2V<br>PWM Operation  | -15<br>-45<br>-20<br>-50   |                  | 15<br>45<br>20<br>50   | mV<br>mV<br>mV<br>mV | •<br>•<br>•<br>•<br>$0.6 \leq V_{OUT} \leq 3.2V$<br>$0.6 \leq V_{OUT} \leq 3.2V$<br>$V_{CC}=LDO5$ |
| VOUT Regulation Accuracy<br>High Output Range<br>0.6V to 5.5V<br>PWM Operation | -30<br>-90<br>-40<br>-100  |                  | 30<br>90<br>40<br>100  | mV<br>mV<br>mV<br>mV | •<br>•<br>•<br>•<br>$0.6 \leq V_{OUT} \leq 5.5V$<br>$0.6 \leq V_{OUT} \leq 4.2V$<br>$V_{CC}=LDO5$ |
| VOUT Regulation Range  | 0.6                        |                  | 5.5                    | V                    | • Without external divider network  |
| VOUT Native Set Point<br>Resolution  |                            | 12.5<br>25<br>50 |                        | mV                   | Low Range<br>Mid Range<br>High Range  |
| VOUT Fine Set Point Resolution <sup>1</sup>                                    |                            | 2.5<br>5<br>10   |                        | mV                   | Low Range<br>Mid Range<br>High Range  |
| VOUT Input Resistance  |                            | 120<br>90<br>75  |                        | k $\Omega$           | Low Range<br>Mid Range<br>High Range  |
| VOUT Input Resistance in PFM<br>Operation                                      |                            | 10<br>1<br>0.67  |                        | M $\Omega$           | Low Range<br>Mid Range<br>High Range  |
| Power Good and OVP Set Point<br>Range (from set point)                         | -155<br>-310<br>-620       |                  | 157.5<br>315<br>630    | mV                   | Low Range<br>Mid Range<br>High Range  |
| Power Good and OVP Set Point<br>Accuracy                                       | -5<br>-10<br>-20           |                  | 5<br>10<br>20          | mV                   | Low Range<br>Mid Range<br>High Range  |

Note 1: Fine Set Point Resolution not available in PFM



A New Direction in Mixed-Signal

# XRP9710 and XRP9711

## Dual 6A Programmable Power Module

### CURRENT AND AUX ADC (MONITORING ADCs)

| Parameter   | Min.  | Typ.           | Max.  | Units |   | Conditions                                      |
|---|-------|----------------|-------|-------|---|---|
| Current Sense Accuracy  | -3.75 | ±1.25          | 3.75  | mV    |   | Low Range ( $\leq 120\text{mV}$ )               |
|   | -10   |                | 10    | mV    | • | -60mV applied                                   |
|   | -5    | ±2.5           | 5     | mV    |   | High Range ( $\leq 280\text{mV}$ )              |
|   | -12.5 |                | +12.5 | mV    | • | -150mV  |
| Current Sense ADC INL   |       | ±0.4           |       | LSB   |   |   |
| DNL   |       | 0.27           |       |       |   |   |
| Current Limit Set Point Resolution and Current Sense ADC Resolution |       | 1.25           |       | mV    |   | Low Range ( $\leq 120\text{mV}$ )               |
|   |       | 2.5            |       | mV    |   | High Range ( $\leq 280\text{mV}$ )              |
| Current Sense ADC Range   | -120  |                | 20    | mV    |   | Low Range ( $\leq 120\text{mV}$ )               |
|   | -280  |                | 40    |       |   | High Range ( $\leq 280\text{mV}$ )              |
| VOUT ADC Resolution   |       | 15<br>30<br>60 |       | mV    |   | Low Range<br>Mid Range<br>High Range            |
| VOUT ADC Accuracy   | -1    |                | 1     | LSB   |   |   |
| V <sub>CC</sub> ADC Range   | 4.6   |                | 25    | V     |   | Note 2  |
| UVLO WARN SET   | 4.4   |                | 4.72  | V     |   | UVLO WARN set point 4.6V, V <sub>CC</sub> =LDO5 |
| UVLO WARN CLEAR   | 4.4   |                | 4.72  | V     |   | UVLO WARN set point 4.6V, V <sub>CC</sub> =LDO5 |
| V <sub>CC</sub> ADC Resolution                                      |       | 200            |       | mV    |   |   |
| V <sub>CC</sub> ADC Accuracy  | -1    |                | 1     | LSB   |   | V <sub>CC</sub> $\leq$ 20V                      |
| Die Temp ADC Resolution   |       | 5              |       | °C    |   |   |
| Die Temp ADC Range  | -44   |                | 156   | °C    |   | Output value is in Kelvin                       |

Note 2: Although Range of V<sub>CC</sub> ADC is technically 0V to 25V, below 4.55 the LDO5 hardware UVLO may have tripped.

### LINEAR REGULATOR

| Parameter  | Min. | Typ. | Max. | Units |   | Conditions   |
|--|------|------|------|-------|---|--|
| LDO5 Output Voltage                              | 4.85 | 5.0  | 5.15 | V     | • | $5.5\text{V} \leq V_{CC} \leq 25\text{V}$<br>$0\text{mA} < I_{LDO5OUT} < 130\text{mA}$ |
| LDO5 Current Limit                               | 135  | 155  | 180  | mA    | • | LDO5 Fault Set   |
| LDO5 UVLO  | 4.74 |      |      | V     | • | V <sub>CC</sub> Rising   |
| LDO5 PGOOD Hysteresis                            |      | 375  |      | mV    |   | V <sub>CC</sub> Falling  |
| Maximum total LDO loading during ENABLE start-up |      |      | 30   | mA    |   | ENABLE transition from logic low to high. Once LDO5 in regulation above limits apply.  |

### PWM GENERATORS AND OSCILLATOR

| Parameter  | Min. | Typ. | Max. | Units | Conditions   |
|--|------|------|------|-------|--|
| Switching Frequency (fsw)<br>Range, Channels 1 and 2 | 124  |      | 1230 | kHz   | See Applications Information                         |
| Switching Frequency (fsw)<br>Range, Channels 3 and 4 | 500  |      | 750  | kHz   |  |
| fsw Accuracy   | -5   |      | 5    | %     |  |
| CLOCK IN<br>Synchronization Frequency                | 20   | 25.7 | 31   | MHz   | When synchronizing to an external clock<br>(Range 1) |
| CLOCK IN<br>Synchronization Frequency                | 10   | 12.8 | 15.5 | MHz   | When synchronizing to an external clock<br>(Range 2) |

### GPIOs<sup>3</sup>

| Parameter   | Min. | Typ. | Max. | Units | Conditions  |
|---|------|------|------|-------|---|
| Input Pin Low Level                                   |      |      | 0.8  | V     |   |
| Input Pin High Level                                  | 2.0  |      |      | V     |   |
| Input Pin Leakage Current                             |      |      | 1    | μA    |   |
| Output Pin Low Level                                  |      |      | 0.4  | V     | I <sub>SINK</sub> = 1mA                                     |
| Output Pin High Level                                 | 2.4  |      |      | V     | I <sub>SOURCE</sub> = 1mA                                   |
| Output Pin High Level                                 |      | 3.3  | 3.6  | V     | I <sub>SOURCE</sub> = 0mA                                   |
| Output Pin High-Z leakage<br>Current (GPIO pins only) |      |      | 10   | μA    |   |
| Maximum Sink Current                                  |      |      | 1    | mA    | Open Drain Mode   |
| I/O Frequency   |      |      | 30   | MHz   | I/O configured for clock synchronization<br>input or output |

Note 3: 3.3V CMOS logic compatible, 5V tolerant.

### PSIOs<sup>4</sup>

| Parameter   | Min. | Typ. | Max. | Units | Conditions  |
|---|------|------|------|-------|---|
| Input Pin Low Level                                   |      |      | 0.8  | V     |   |
| Input Pin High Level                                  | 2.0  |      |      | V     |   |
| Input Pin Leakage Current                             |      |      | 1    | μA    |   |
| Output Pin Low Level                                  |      |      | 0.4  | V     | I <sub>SINK</sub> = 3mA                                 |
| Output Pin High Level                                 |      |      | 15   | V     | Open Drain. External pull-up resistor to<br>user supply |
| Output Pin High-Z leakage<br>Current (PSIO pins only) |      |      | 10   | μA    |   |
| I/O Frequency   |      |      | 5    | MHz   |   |

Note 4: 3.3V/5.0V CMOS logic compatible, maximum rating of 15.0V



A New Direction in Mixed-Signal

# XRP9710 and XRP9711

## Dual 6A Programmable Power Module

### SMBUS (I<sup>2</sup>C) INTERFACE

| Parameter  | Min.        | Typ. | Max.    | Units   | Conditions                                       |
|--|-------------|------|---------|---------|--|
| Input Pin Low Level, $V_{IL}$                            |             |      | 0.3 VIO | V       | VIO = 3.3 V $\pm$ 10%                            |
| Input Pin High Level, $V_{IH}$                           | 0.7 VIO     |      |         | V       | VIO = 3.3 V $\pm$ 10%                            |
| Hysteresis of Schmitt Trigger inputs, $V_{hys}$          | 0.05 VIO    |      |         | V       | VIO = 3.3 V $\pm$ 10%                            |
| Output Pin Low Level (open drain or collector), $V_{OL}$ |             |      | 0.4     | V       | $I_{SINK} = 3mA$                                 |
| Input leakage current                                    | -10         |      | 10      | $\mu A$ | Input is between 0.1 VIO and 0.9 VIO             |
| Output fall time from $V_{IHmin}$ to $V_{ILmax}$         | 20 + 0.1 Cb |      | 250     | ns      | With a bus capacitance (Cb) from 10 pF to 400 pF |
| Internal Pin Capacitance                                 |             |      | 1       | pF      |  |

### GATE DRIVERS

| Parameter                                   | Min. | Typ. | Max. | Units      | Conditions  |
|---|------|------|------|------------|---|
| GH, GL Rise Time                            |      | 17   |      | ns         | At 10-90% of full scale, 1nF $C_{load}$   |
| GH, GL Fall Time                            |      | 11   |      | ns         |   |
| GH, GL Pull-Up On-State Output Resistance   |      | 4    | 5    | $\Omega$   |   |
| GH, GL Pull-Down On-State Output Resistance |      | 2    | 2.5  | $\Omega$   |   |
| GH, GL Pull-Down Resistance in Off-Mode     |      | 50   |      | k $\Omega$ | $V_{CC} = V_{CCD} = 0V.$  |
| Bootstrap diode forward resistance          |      | 9    |      | $\Omega$   | @ 10mA  |
| Minimum On Time                             |      | 50   |      | ns         | 1nF of gate capacitance.  |
| Minimum Off Time                            |      | 125  |      | ns         | 1nF of gate capacitance   |
| Minimum Programmable Dead Time              |      | 20   |      | ns         | Does not include dead time variation from driver output stage<br>Tsw=switching period |
| Maximum Programmable Dead Time              |      | Tsw  |      |            |   |
| Programmable Dead Time Adjustment Step      |      | 607  |      | ps         |   |



### BLOCK DIAGRAMS

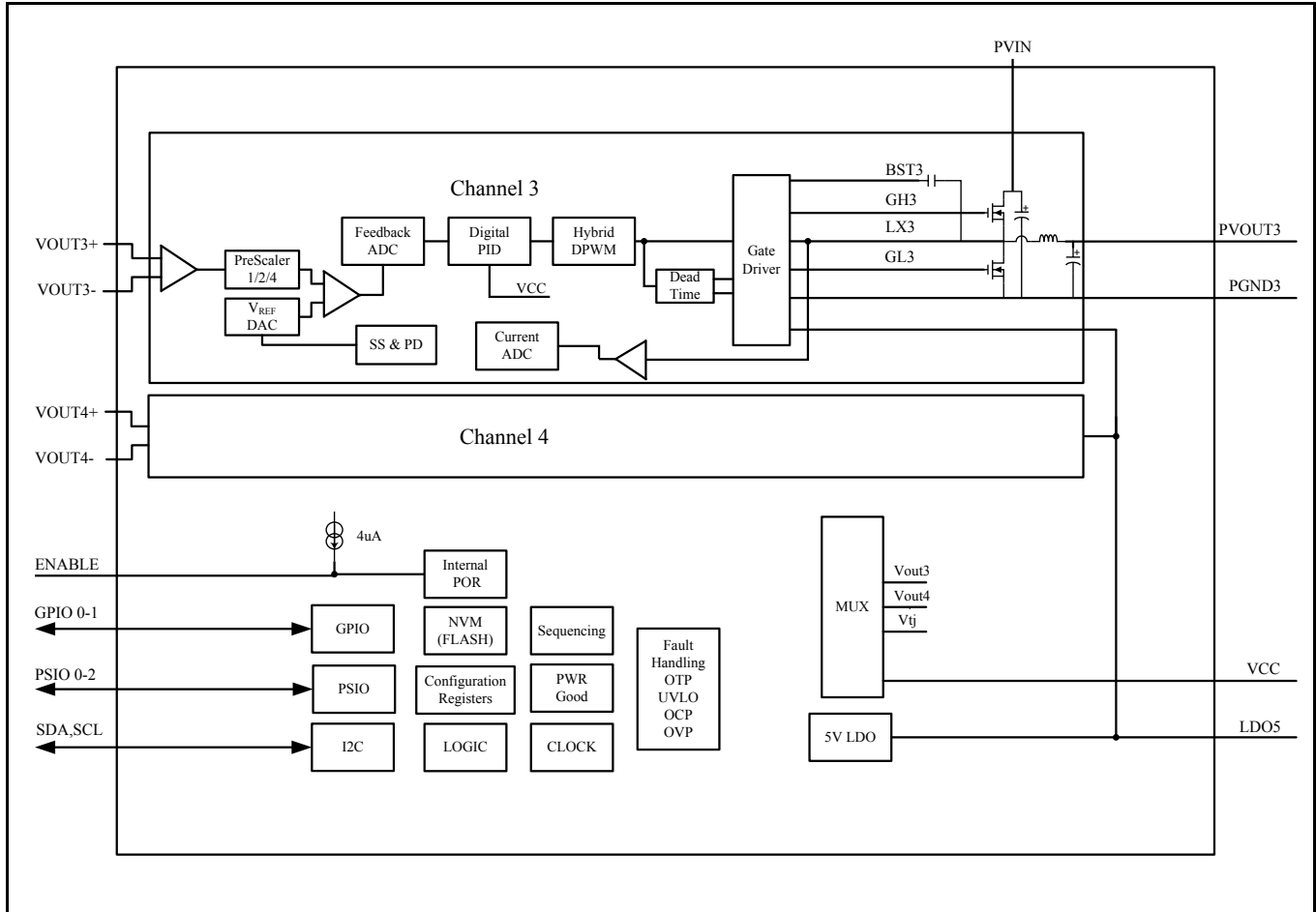

Figure 3 XRP9710 Block Diagram

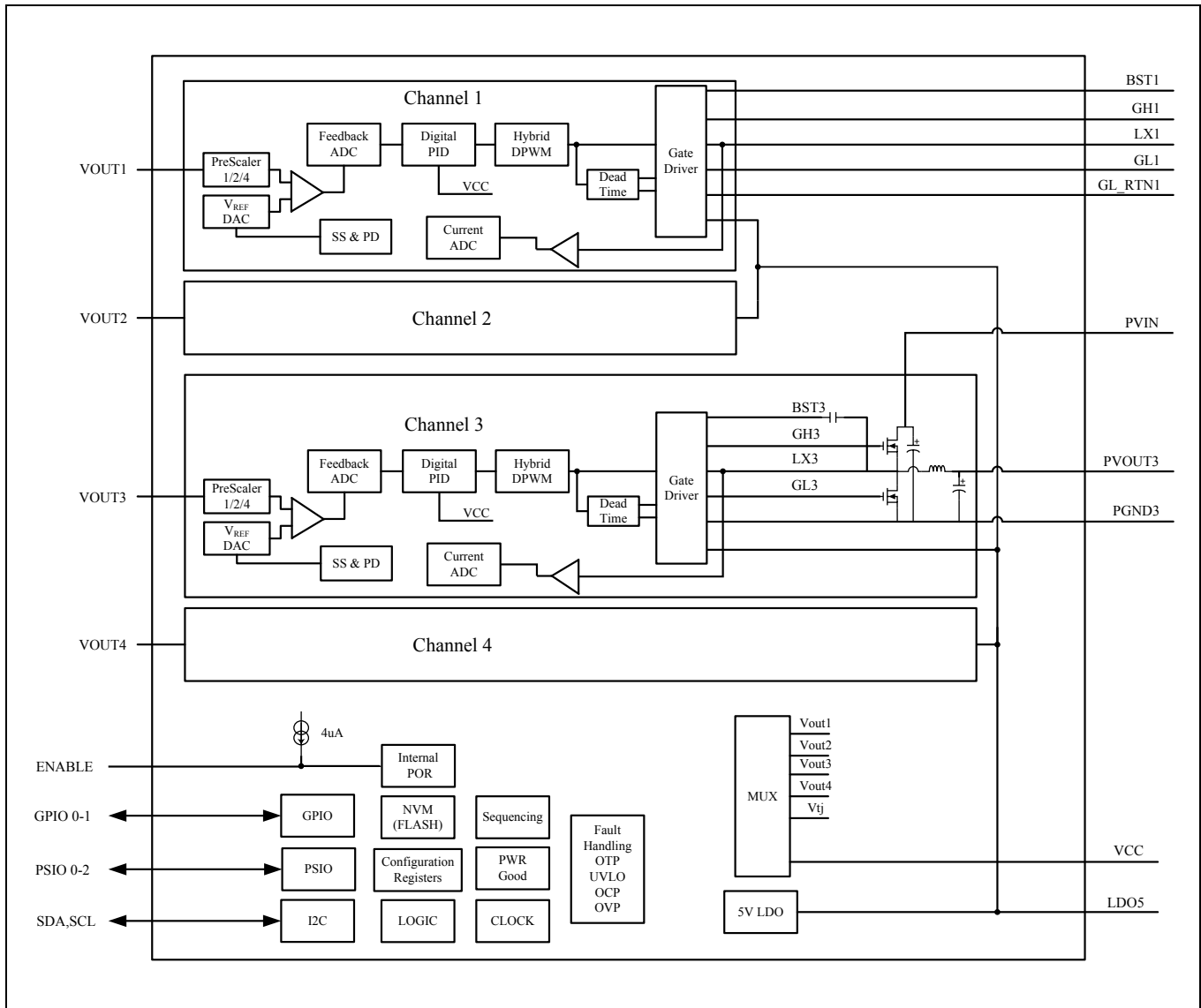

Figure 4 XRP9711 Block Diagram

### XRP9710 PIN ASSIGNMENT

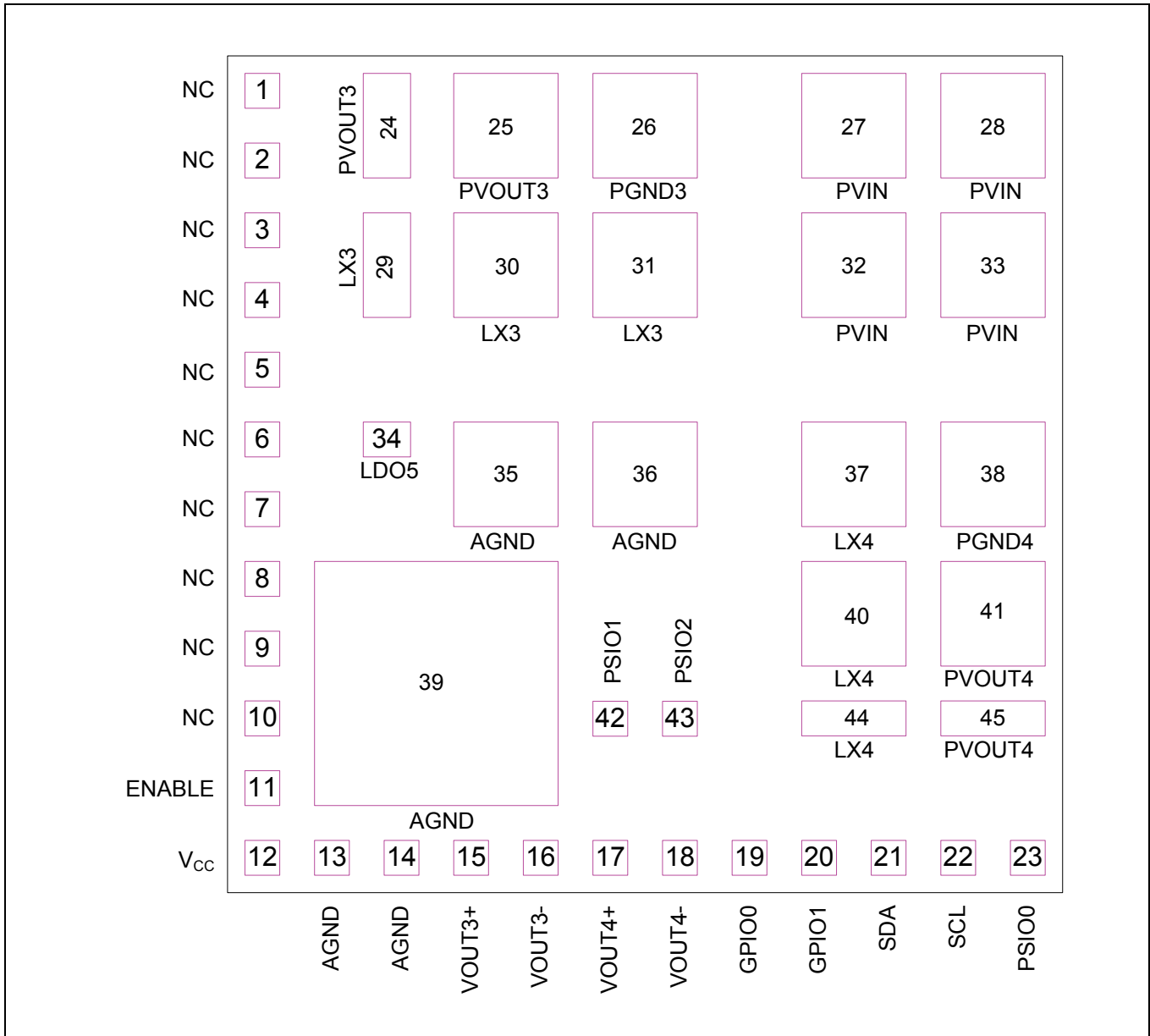

Figure 5 XRP9710 Pin Assignment, Top View



A New Direction in Mixed-Signal

# XRP9710 and XRP9711

## Dual 6A Programmable Power Module

### XRP9710 PIN DESCRIPTION

| Pin # | Name            | Description  |
|-------|-----------------|--|
| 1-10  | NC              | <b>No Connect</b>  |
| 11    | ENABLE          | <b>Enable.</b> If ENABLE is pulled high or allowed to float high, the chip is powered up. The pin must be held low for the XRP9710 to be placed into shutdown.   |
| 12    | V <sub>CC</sub> | <b>Controller Supply Voltage.</b> Place a decoupling capacitor close to the controller IC. This input is used in UVLO fault generation.                          |
| 13    | AGND            | <b>Analog Ground.</b> This is the small signal ground connection.  |
| 14    | AGND            | <b>Analog Ground.</b> This is the small signal ground connection.  |
| 15    | VOUT3+          | <b>Feedback Pin.</b> Positive input of remote sensing differential amplifier. Connect to the remote voltage load, positive terminal.                             |
| 16    | VOUT3-          | <b>Feedback Pin.</b> Negative input of remote sensing differential amplifier. Connect to the remote voltage load, negative terminal.                             |
| 17    | VOUT4+          | <b>Feedback Pin.</b> Positive input of remote sensing differential amplifier. Connect to the remote voltage load, positive terminal.                             |
| 18    | VOUT4-          | <b>Feedback Pin.</b> Negative input of remote sensing differential amplifier. Connect to the remote voltage load, negative terminal.                             |
| 19    | GPIO0           | <b>I/O Logic Signal.</b> Can be configured as input or output.   |
| 20    | GPIO1           | <b>I/O Logic Signal.</b> Can be configured as input or output.   |
| 21    | SDA             | <b>I<sup>2</sup>C Data.</b> SMBus/I <sup>2</sup> C serial interface communication.   |
| 22    | SCL             | <b>I<sup>2</sup>C Clock.</b> SMBus/I <sup>2</sup> C serial interface communication.  |
| 23    | PSIO0           | <b>I/O Logic Signal, HV.</b> Open drain, high voltage compliant. Can be configured as input or output.   |
| 24    | PVOUT3          | <b>Channel Output Power.</b> Output voltage for the internal channel.  |
| 25    | PVOUT3          | <b>Channel Output Power.</b> Output voltage for the internal channel.  |
| 26    | PGND3           | <b>Channel Output Ground.</b> Output ground for the internal channel.  |
| 27    | PVIN            | <b>Channel Input Power.</b> Internally connected to drain of upper switching MOSFET  |
| 28    | PVIN            | <b>Channel Input Power.</b> Internally connected to drain of upper switching MOSFET  |
| 29    | LX3             | <b>Switch Node.</b> Switch node of the internal channel.   |
| 30    | LX3             | <b>Switch Node.</b> Switch node of the internal channel.   |
| 31    | LX3             | <b>Switch Node.</b> Switch node of the internal channel.   |
| 32    | PVIN            | <b>Channel Input Power.</b> Internally connected to drain of upper switching MOSFET  |
| 33    | PVIN            | <b>Channel Input Power.</b> Internally connected to drain of upper switching MOSFET  |
| 34    | LDO5            | <b>5V LDO Output.</b> Used internally for power and may also be used for external power. LDO that can remain active while the rest of the IC is in standby mode. |
| 35    | AGND            | <b>Analog Ground.</b> This is the small signal ground connection.  |
| 36    | AGND            | <b>Analog Ground.</b> This is the small signal ground connection.  |
| 37    | LX4             | <b>Switch Node.</b> Switch node of the internal channel.   |
| 38    | PGND4           | <b>Channel Output Ground.</b> Output ground for the internal channel.  |
| 39    | AGND            | <b>Analog Ground.</b> This is the small signal ground connection.  |
| 40    | LX4             | <b>Switch Node.</b> Switch node of the internal channel.   |
| 41    | PVOUT4          | <b>Channel Output Power.</b> Output voltage for the internal channel.  |
| 42    | PSIO1           | <b>I/O Logic Signal, HV.</b> Open drain, high voltage compliant. Can be configured as input or output.   |
| 43    | PSIO2           | <b>I/O Logic Signal, HV.</b> Open drain, high voltage compliant. Can be configured as input or output.   |
| 44    | LX4             | <b>Switch Node.</b> Switch node of the internal channel.   |
| 45    | PVOUT4          | <b>Channel Output Power.</b> Output voltage for the internal channel.  |

### XRP9711 PIN ASSIGNMENT

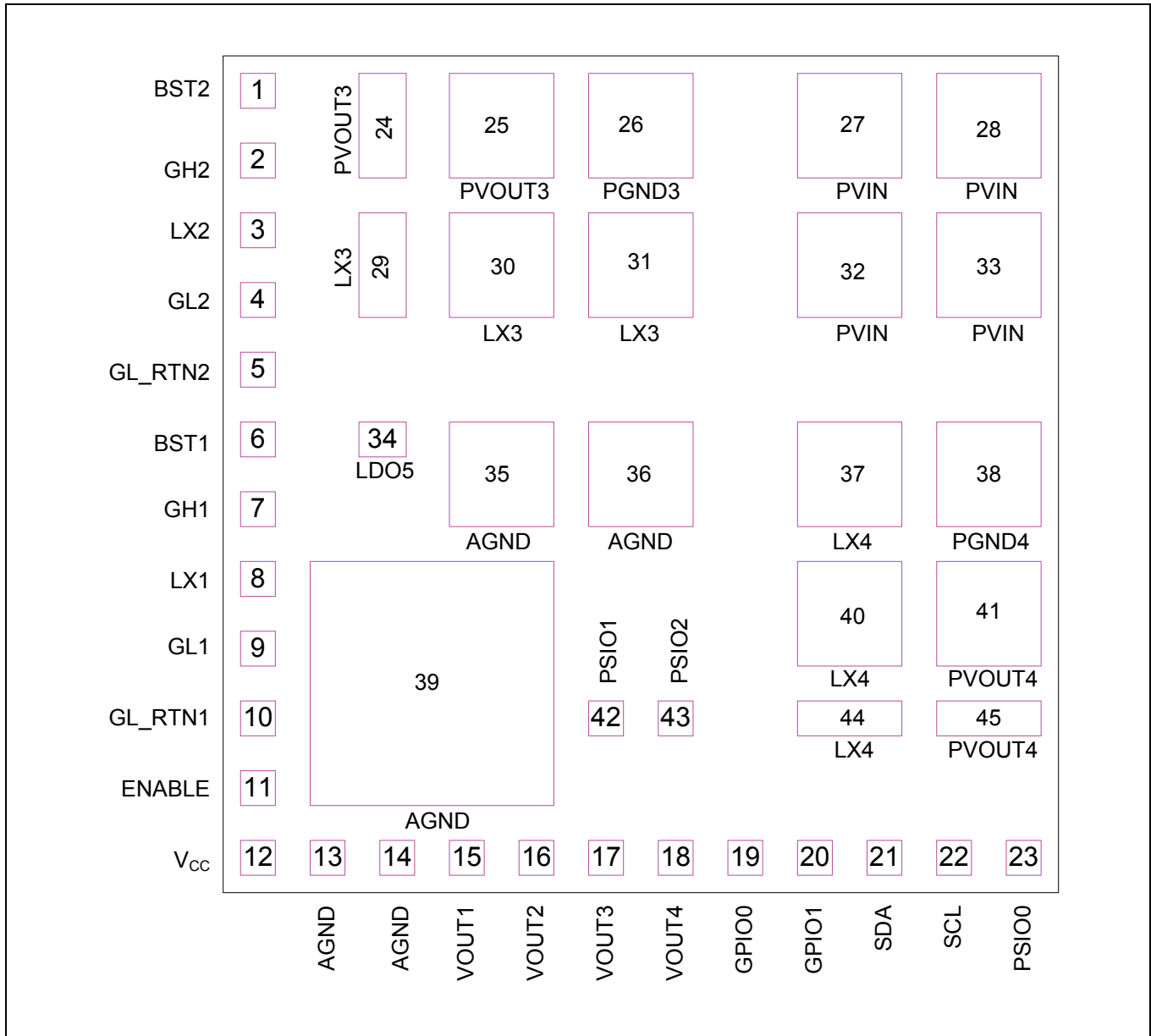

Figure 6 XRP9711 Pin Assignment, Top View



### XRP9711 PIN DESCRIPTION

| Pin # | Name            | Description   |
|-------|-----------------|---|
| 1     | BST2            | <b>Boost pin.</b> High side driver supply input.  |
| 2     | GH2             | <b>High Side Gate Drive Out.</b> Connect directly to the gate of an external N-channel MOSFET.  |
| 3     | LX2             | <b>Switch Node.</b> Return for the high-side gate driver. Connect directly to the drain of the lower FET. Also used to measure voltage drop across bottom MOSFETs |
| 4     | GL2             | <b>Low Side Gate Drive Out.</b> Connect directly to the gate of an external N-channel MOSFET.   |
| 5     | GL_RTN2         | <b>Low Side Gate Drive Return.</b> This should be routed as a differential trace with GL. Connect to the source of the low side MOSFET.                           |
| 6     | BST1            | <b>Boost pin.</b> High side driver supply input.  |
| 7     | GH1             | <b>High Side Gate Drive Out.</b> Connect directly to the gate of an external N-channel MOSFET.  |
| 8     | LX1             | <b>Switch Node.</b> Return for the high-side gate driver. Connect directly to the drain of the lower FET. Also used to measure voltage drop across bottom MOSFETs |
| 9     | GL1             | <b>Low Side Gate Drive Out.</b> Connect directly to the gate of an external N-channel MOSFET.   |
| 10    | GL_RTN1         | <b>Low Side Gate Drive Return.</b> This should be routed as a differential trace with GL. Connect to the source of the low side MOSFET.                           |
| 11    | ENABLE          | <b>Enable.</b> If ENABLE is pulled high or allowed to float high, the chip is powered up. The pin must be held low for the XRP9711 to be placed into shutdown.    |
| 12    | V <sub>CC</sub> | <b>Controller Supply Voltage.</b> Place a decoupling capacitor close to the controller IC. This input is used in UVLO fault generation.                           |
| 13    | AGND            | <b>Analog Ground.</b> This is the small signal ground connection.   |
| 14    | AGND            | <b>Analog Ground.</b> This is the small signal ground connection.   |
| 15    | VOUT1           | <b>Feedback Pin.</b> Connect to the output of the corresponding power stage   |
| 16    | VOUT2           | <b>Feedback Pin.</b> Connect to the output of the corresponding power stage   |
| 17    | VOUT3           | <b>Feedback Pin.</b> Connect to the output of the corresponding power stage   |
| 18    | VOUT4           | <b>Feedback Pin.</b> Connect to the output of the corresponding power stage   |
| 19    | GPIO0           | <b>I/O Logic Signal.</b> Can be configured as input or output.  |
| 20    | GPIO1           | <b>I/O Logic Signal.</b> Can be configured as input or output.  |
| 21    | SDA             | <b>I<sup>2</sup>C Data.</b> SMBus/I <sup>2</sup> C serial interface communication.  |
| 22    | SCL             | <b>I<sup>2</sup>C Clock.</b> SMBus/I <sup>2</sup> C serial interface communication.   |
| 23    | PSIO0           | <b>I/O Logic Signal, HV.</b> Open drain, high voltage compliant. Can be configured as input or output.  |
| 24    | PVOUT3          | <b>Channel Output Power.</b> Output voltage for the internal channel.   |
| 25    | PVOUT3          | <b>Channel Output Power.</b> Output voltage for the internal channel.   |
| 26    | PGND3           | <b>Channel Output Ground.</b> Output ground for the internal channel.   |
| 27    | PVIN            | <b>Channel Input Power.</b> Internally connected to drain of upper switching MOSFET   |
| 28    | PVIN            | <b>Channel Input Power.</b> Internally connected to drain of upper switching MOSFET   |
| 29    | LX3             | <b>Switch Node.</b> Switch node of the internal channel.  |
| 30    | LX3             | <b>Switch Node.</b> Switch node of the internal channel.  |
| 31    | LX3             | <b>Switch Node.</b> Switch node of the internal channel.  |
| 32    | PVIN            | <b>Channel Input Power.</b> Internally connected to drain of upper switching MOSFET   |
| 33    | PVIN            | <b>Channel Input Power.</b> Internally connected to drain of upper switching MOSFET   |
| 34    | LDO5            | <b>5V LDO Output.</b> Used internally for power and may also be used for external power. LDO that can remain active while the rest of the IC is in standby mode.  |
| 35    | AGND            | <b>Analog Ground.</b> This is the small signal ground connection.   |
| 36    | AGND            | <b>Analog Ground.</b> This is the small signal ground connection.   |
| 37    | LX4             | <b>Switch Node.</b> Switch node of the internal channel.  |
| 38    | PGND4           | <b>Channel Output Ground.</b> Output ground for the internal channel.   |
| 39    | AGND            | <b>Analog Ground.</b> This is the small signal ground connection.   |
| 40    | LX4             | <b>Switch Node.</b> Switch node of the internal channel.  |
| 41    | PVOUT4          | <b>Channel Output Power.</b> Output voltage for the internal channel.   |



A New Direction in Mixed-Signal

# XRP9710 and XRP9711

## Dual 6A Programmable Power Module

| Pin # | Name   | Description  |
|-------|--------|--|
| 42    | PSIO1  | <b>I/O Logic Signal, HV.</b> Open drain, high voltage compliant. Can be configured as input or output. |
| 43    | PSIO2  | <b>I/O Logic Signal, HV.</b> Open drain, high voltage compliant. Can be configured as input or output. |
| 44    | LX4    | <b>Switch Node.</b> Switch node of the internal channel.   |
| 45    | PVOUT4 | <b>Channel Output Power.</b> Output voltage for the internal channel.                                  |

### ORDERING INFORMATION

| Part Number           | Temperature Range               | Marking   | Package        | Packing Quantity | Note 1       | I <sup>2</sup> C Default Address |
|-----------------------|---------------------------------|---|----------------|------------------|--------------|----------------------------------|
| XRP9710EY-F           | -40°C ≤ T <sub>J</sub> ≤ +125°C | 9710EY<br>FWWYY<br>Lot #  | 12x12mm<br>LGA | Tray             | Halogen Free | 0x28 (7Bit)                      |
| XRP9710EYTR-F         |                                 |   |                | 2.5K/Tape & Reel |              |                                  |
| XRP9711EY-F           |                                 | 9711EY<br>FWWYY<br>Lot #  |                | Tray             |              |                                  |
| XRP9711EYTR-F         |                                 |   |                | 2.5K/Tape & Reel |              |                                  |
| XRP9710EVB-DEMO-1-KIT |                                 | Evaluation kit includes XRP9710EVB-DEMO-1 Evaluation Board with Power Architect software and controller board |                |                  |              |                                  |
| XRP9711EVB-DEMO-1-KIT |                                 | Evaluation kit includes XRP9711EVB-DEMO-1 Evaluation Board with Power Architect software and controller board |                |                  |              |                                  |

"F" denotes "-F" part number suffix - "YY" = Year - "WW" = Work Week

### TYPICAL PERFORMANCE CHARACTERISTICS

All data taken at  $V_{CC} = 12V$ ,  $T_J = T_A = 25^\circ C$ , unless otherwise specified - Schematic and BOM from XRP9711EVB. See XRP9711EVB-DEMO-1 Manual.

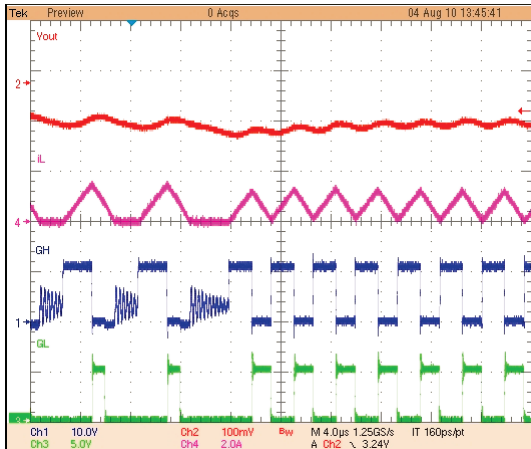

Figure 7 PFM to PWM Transition

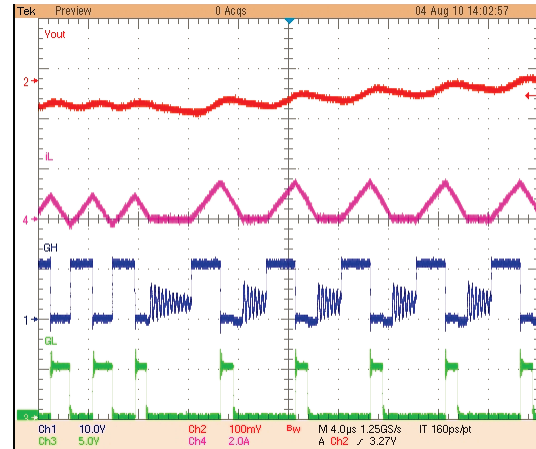

Figure 8 PWM to PFM Transition

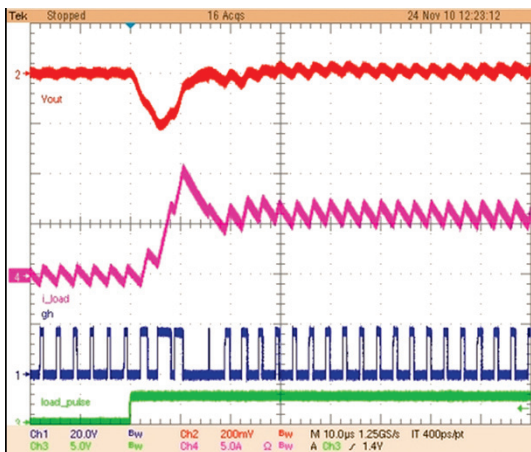

Figure 9 0-6A Transient 300kHz PWM only

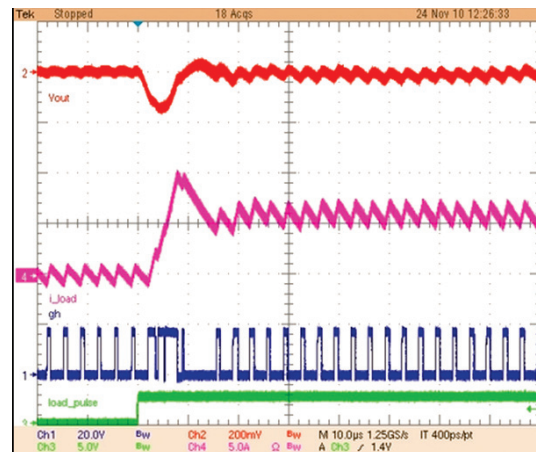

Figure 10 0-6A Transient 300kHz with OVS  $\pm 5.5\%$

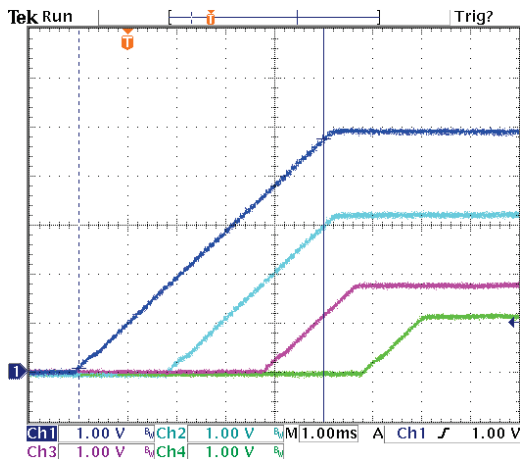

Figure 11 Sequential Start-up

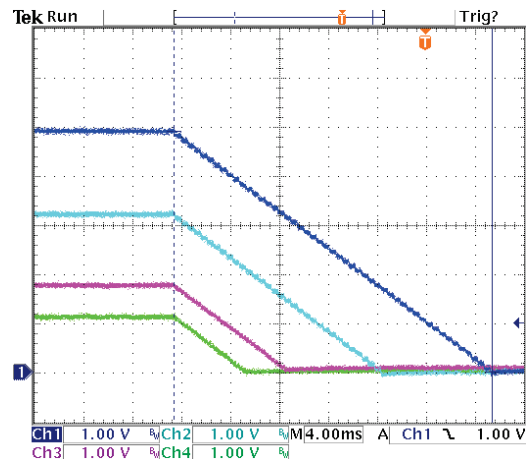

Figure 12 Sequential Shut Down





A New Direction in Mixed-Signal

# XRP9710 and XRP9711

## Dual 6A Programmable Power Module

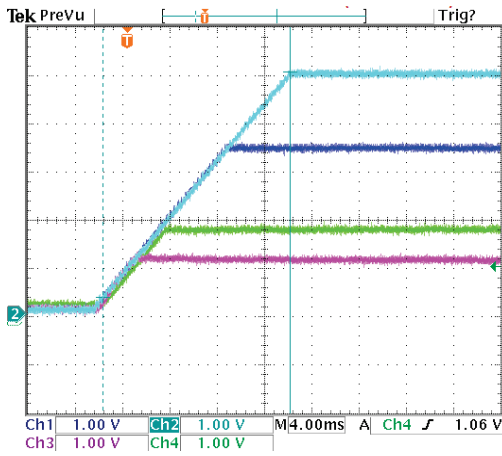

Figure 13 Simultaneous Start-up

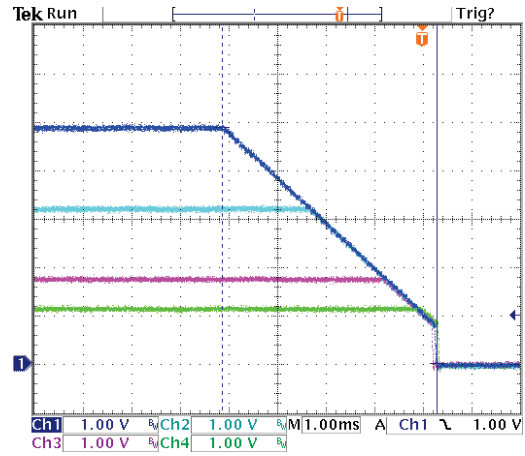

Figure 14 Simultaneous Shut Down

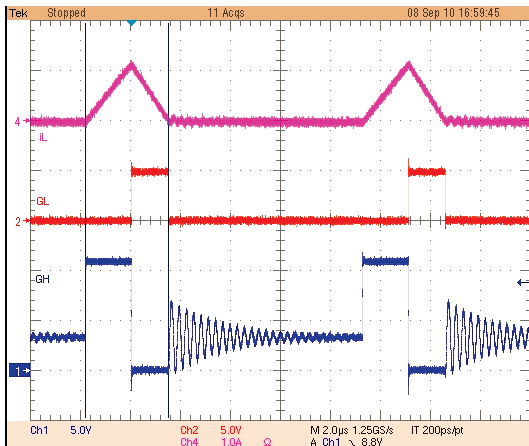

Figure 15 PFM Zero Current Accuracy

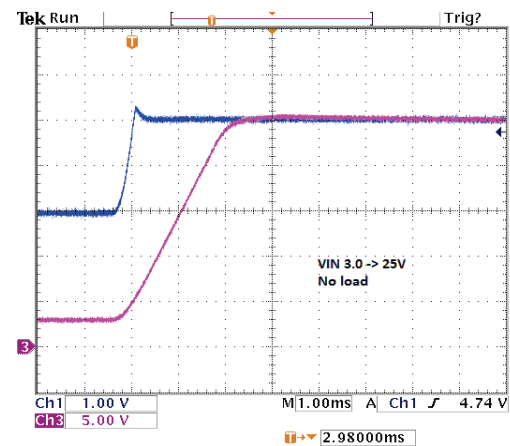

Figure 16 LDO5 Brown Out Recovery, No Load

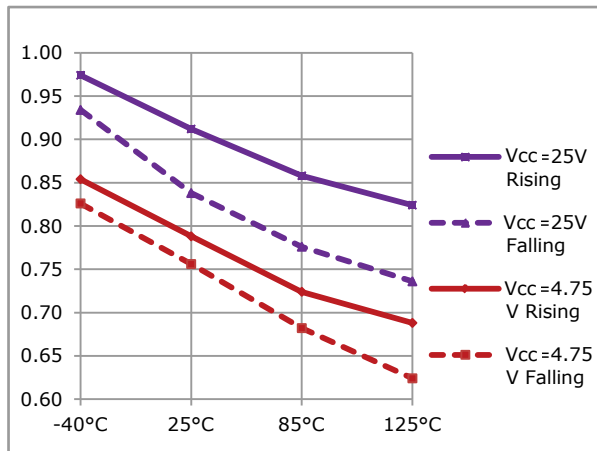

Figure 17 Enable Threshold Over Temp

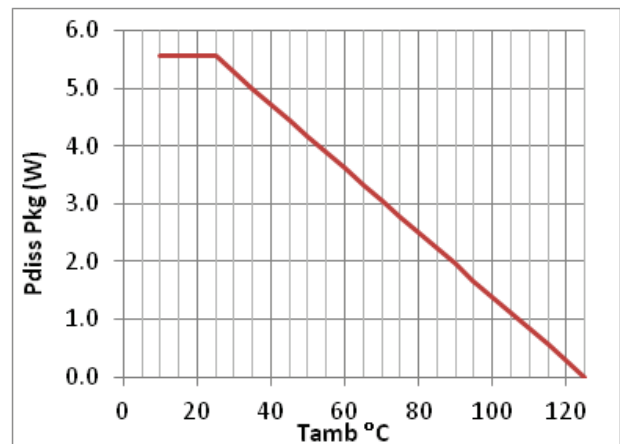

Figure 18 Package Thermal Derating



A New Direction in Mixed-Signal

# XRP9710 and XRP9711

## Dual 6A Programmable Power Module

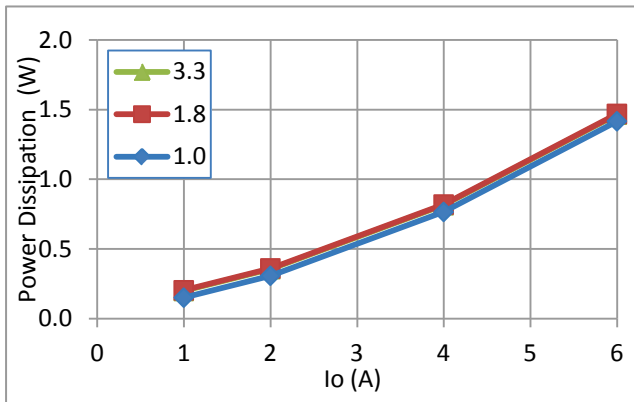

Figure 19 Vin = 5V Power Dissipation

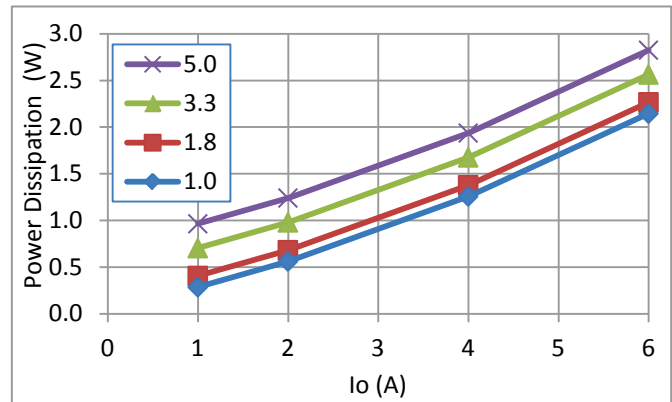

Figure 20 Vin = 12V Power Dissipation

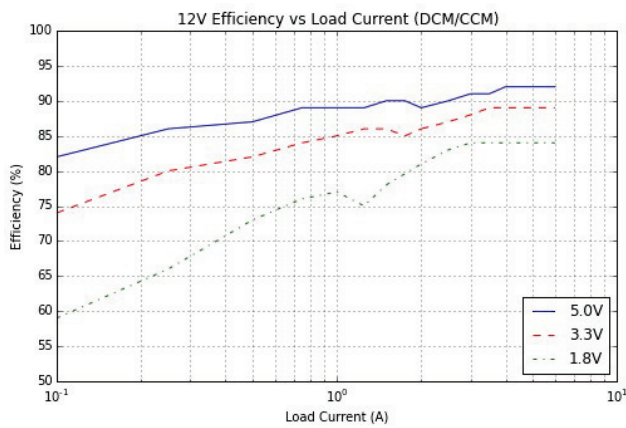

Figure 21 Efficiency, 12V<sub>IN</sub>, 600kHz



A New Direction in Mixed-Signal

## XRP9710 and XRP9711

### Dual 6A Programmable Power Module

#### FUNCTIONAL OVERVIEW

The XRP9710 is a digital pulse width modulation (DPWM) power module with two 6A converters. In addition, the XRP9711 provides two additional PWM controller outputs which can directly drive external power stage. Each output voltage can be programmed from 0.6V to 5.5V without the need for an external voltage divider. The wide range of programmable DPWM switching frequencies (from 124 kHz to 1.23 MHz) enables the user to optimize for efficiency or component sizes. Since the digital regulation loop requires no external passive components, loop performance is not compromised due to external component variation or operating conditions.

The XRP9710/1 provides a number of critical safety features, such as Over-Current Protection (OCP), Over-Voltage Protection (OVP), Over-Temperature Protection (OTP) plus input Under-Voltage Lockout (UVLO). In addition, a number of key health monitoring features including warning level flags for the safety functions, Power Good (PGOOD), plus full monitoring of system voltages and currents. The above are all programmable and/or readable from the SMBus and many are steerable to the GPIOs for hardware monitoring.

For hardware communication, the XRP9710/1 has two logic level General Purpose Input-Output (GPIO) pins and three, 15V, open-drain, Power System Input-Output (PSIO) pins. Two pins are dedicated to the SMBus data (SDA) and clock (SCL).

The 5V LDO is used for internal power and is also optionally available to power external circuitry.

The primary benefit of these modules is the ultra small footprint and height, but these come with a full suite of advanced power management capabilities. All outputs are independently programmable which provides the user full control of the delay, ramp rate, and sequence during power up and power down. The user may also control how the outputs interact and power down in the event of a fault. This includes active ramp down of the output voltages to take down an output voltage as quickly as possible. Another useful feature is that the outputs can be defined and controlled as groups.

The XRP9710/1 has two main types of programmable memory. The first type is runtime registers that contain configuration, control and monitoring information for the chip. The second type is rewritable Non-Volatile Flash Memory (NVFM) that is used for permanent storage of the configuration data along with various chip internal functions. During power up, the run time registers are loaded from the NVFM allowing for standalone operation.

The XRP9710/1 brings an extremely high level of functionality and performance to a programmable power system. Ever decreasing product budgets require the designer to quickly analyze cost/performance tradeoffs to be truly successful. By incorporating four switching channels, a user LDO, and internal gate drivers, all in a single package, the XRP9710/1 allows for extremely cost effective power system designs. Another key cost factor that is often overlooked is the unanticipated Engineering Change Order (ECO). The programmable versatility of the XRP9710/1, along with the lack of hard wired, on board configuration components, allows for minor and major changes to be made on the board by simple reprogramming.

### THEORY OF OPERATION

#### CHIP ARCHITECTURE

#### REGULATION LOOPS

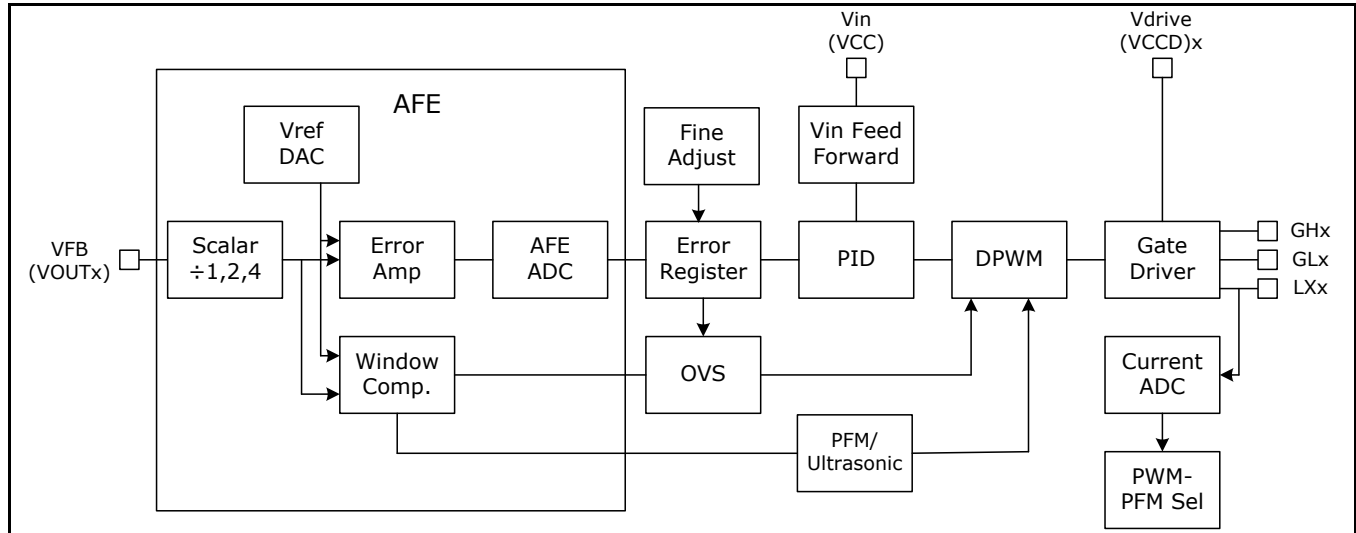

Figure 22 XRP9710 Regulation Loops

Figure 22 shows a functional block diagram of the regulation loops for an output channel. There are four separate parallel control loops; Pulse Width Modulation (PWM), Pulse Frequency Modulation (PFM), Ultrasonic, and Over Sampling (OVS). Each of these loops is fed by the Analog Front End (AFE) as shown at the left of the diagram. The AFE consist of an input voltage scaler, a programmable Voltage Reference (Vref) DAC, Error Amplifier, and a window comparator. (Please note that the block diagram shown is simplified for ease of understanding. Some of the functional blocks are common and shared by each channel by means of a multiplexer.)

#### PWM Loop

The PWM loop operates in Voltage Control Mode (VCM) with optional  $V_{IN}$  feed forward based on the voltage at the  $V_{CC}$  pin. The reference voltage (Vref) for the error amp is generated by a 0.15V to 1.6V DAC that has a 12.5mV resolution. In order to provide a full 0.6V to 5.5V output voltage range, an input scaler is used to reduce feedback voltages for higher output voltages to bring them within the 0.15V to 1.6V control range. So for output

voltages up to 1.6V (low range) the scaler has a gain of 1. For output voltages from 1.6V to 3.2V (mid range) the scaler gain is 1/2 and for voltages greater than 3.2V (high range) the gain is 1/4. This results in the low range having a reference voltage resolution of 12.5mV, the mid range having a resolution of 25mV and the high range having a resolution of 50mV. The error amp has a gain of 4 and compares the output voltage of the scaler to Vref to create an error voltage on its output. This is converted to a digital error term by the AFE ADC and is stored in the error register. The error register has a fine adjust function that can be used to improve the output voltage set point resolution by a factor of 5 resulting in a low range resolution of 2.5mV, a mid range resolution of 5mV and a high range resolution of 10mV. The output of the error register is then used by the Proportional Integral Derivative (PID) controller to manage the loop dynamics.

The XRP9710/1 PID is a 17-bit five-coefficient control engine that calculates the required duty cycle under the various operating conditions and feeds it to the Digital Pulse Width Modulator (DPWM). Besides the normal

coefficients the PID also uses the  $V_{IN}$  voltage to provide a feed forward function.

The XRP9710/1 DPWM includes a special delay timing loop that provides a timing resolution that is 16 times the master oscillator frequency (103MHz) for a timing resolution of 607ps for both the driver pulse width and dead time delays. The DPWM produces the Gate High (GH) and Gate Low (GL) signals for the driver. The maximum and minimum on-times and dead time delays are programmable by configuration resistors.

To provide current information, the output inductor current is measured by a differential amplifier that reads the voltage drop across the  $R_{DS}$  of the lower FET during its on time. There are two selectable ranges, a low range with a gain of 8 for a +20mV to -120 mV range, and a high range with a gain of 4 for a +40mV to -280mV range. The optimum range to use will depend on the maximum output current and the  $R_{DS}$  of the lower FET. The measured voltage is then converted to a digital value by the current ADC block. The resulting current value is stored in a readable register, and also used to determine when PWM to PFM transitions should occur.

### PFM mode loop

The XRP9710/1 has a PFM loop that can be enabled to improve efficiency at light loads. By reducing switching frequency and operating in the discontinuous conduction mode (DCM), both switching and  $I^2R$  losses are minimized.

Figure 23 shows a functional diagram of the PFM logic.

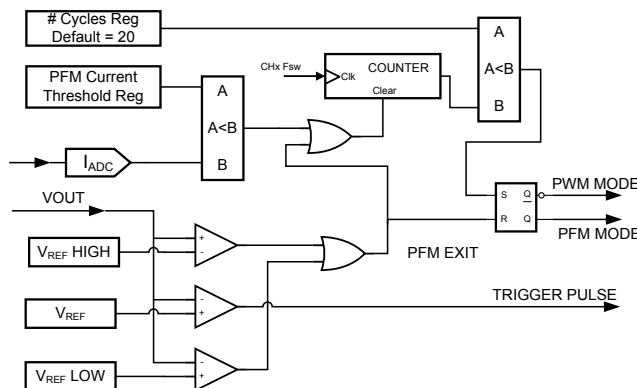

Figure 23 PFM Enter/Exit Functional Diagram

The PFM loop works in conjunction with the PWM loop and is entered when the output current falls below a programmed threshold level for a programmed number of cycles. When PFM mode is entered, the PWM loop is disabled and instead, the scaled output voltage is compared to  $V_{ref}$  with a window comparator. The window comparator has three thresholds; normal ( $V_{ref}$ ), high ( $V_{ref} + \%high$ ) and low ( $V_{ref} - \%low$ ). The  $\%high$  and  $\%low$  values are programmable and track  $V_{ref}$ .

In PFM mode, the normal comparator is used to regulate the output voltage. If the output voltage falls below the  $V_{ref}$  level, the comparator is activated and triggers the DPWM to start a switching cycle. When the high side FET is turned on, the inductor current ramps up which charges up the output capacitors and increases their voltage. After the completion of the high side and low side on-times, the lower FET is turned off to inhibit any inductor reverse current flow. The load current then discharges the output capacitors until the output voltage falls below  $V_{ref}$  and the normal comparator is activated. This triggers the DPWM to start the next switching cycle. The time from the end of the switching cycle to the next trigger is referred to as the dead zone. When PFM mode is initially entered the switching duty cycle is equal to the steady-state PWM duty cycle. This will cause the inductor ripple current to be the same level that it was in PWM mode. During operation the PFM duty cycle is calculated based on the ratio of the output voltage to  $V_{CC}$ . This method ensures that the output voltage ripple is well controlled and is much lower than other architectures which use a "burst" methodology.

If the output voltage goes outside the high/low windows, PFM mode is exited and the PWM loop is reactivated.

Although the PFM mode is effective at improving efficiency at light load, at very light loads the dead zone time can increase to the point where the switching frequency can enter the audio hearing range. When this happens some components, like the output inductor and ceramic capacitors, can emit audible



A New Direction in Mixed-Signal

# XRP9710 and XRP9711

## Dual 6A Programmable Power Module

noise. The amplitude of the noise depends mainly on the board design and on the manufacturer and construction details of the components. Proper selection of components can reduce the sound to very low levels. In general Ultrasonic Mode is not used unless required as it reduces light load efficiency.

### Ultrasonic Mode

Ultrasonic mode is an extension of PFM to ensure that the switching frequency never enters the audible range. When this mode is entered, the switching frequency is set to 30kHz and the duty cycle of the upper and lower FETs, which are fixed in PFM mode, are decreased as required to keep the output voltage in regulation while maintaining the 30kHz switching frequency.

Under extremely light or zero load currents, the GH on time pulse width can decrease to its minimum width. When this happens, the lower FET on time is increased slightly to allow a small amount of reverse inductor current to flow back into  $V_{IN}$  to keep the output voltage in regulation while maintaining the switching frequency above the audio range.

### Oversampling OVS Mode

Oversampling (OVS) mode is a feature added to the XRP9711 to improve transient response for the two external channels. This mode can only be enabled when the channel switching frequency is operating in 1x frequency mode. In OVS mode the output voltage is sampled four times per switching cycle and is monitored by the AFE window comparators. If the voltage goes outside the set high or low limits, the OVS control electronics can immediately modify the pulse width of the GH or GL drivers to respond accordingly, without having to wait for the next cycle to start. OVS has two types of response depending on whether the high limit is exceeded during an unloading transient (Over Voltage), or the low limit is exceeded during a loading transient (Under Voltage).

**Under Voltage OVS:** If there is an increasing current load step, the output voltage will drop until the regulator loop adapts to the new conditions to return the voltage to the correct

level. Depending on where in the switching cycle the load step happens there can be a delay of up to one switching cycle before the control loop can respond. With OVS enabled if the output voltage drops below the lower level, an immediate GH pulse will be generated and sent to the driver to increase the output inductor current toward the new load level without having to wait for the next cycle to begin. If the output voltage is still below the lower limit at the beginning of the next cycle, OVS will work in conjunction with the PID to insert additional GH pulses to quickly return the output voltage back within its regulation band. The result of this system is transient response capabilities on par or exceeding those of a constant on-time control loop.

**Over Voltage OVS:** When there is a step load current decrease, the output voltage will increase (bump up) as the excess inductor current that is no longer used by the load flows into the output capacitors causing the output voltage to rise. The voltage will continue to rise until the inductor current decreases to the new load current. With OVS enabled, if the output voltage exceeds the high limit of the window comparator, a blanking pulse is generated to truncate the GH signal. This causes inductor current to immediately begin decreasing to the new load level. The GH signal will continue to be blanked until the output voltage falls below the high limit. Again, since the output voltage is sampled at four times the switching frequency, over shoot will be decreased and the time required to get back into the regulation band is also decreased.

OVS can be used in conjunction with both the PWM and PFM operating modes. When it is activated it can noticeably decrease output voltage excursions when transitioning between PWM and PFM modes.

### LDOS

The XRP9710/1 has an internal Low Drop-Out (LDO) linear regulator that generates 5.0V (LDO5) for both internal and external use. LDO5 is the main power input to the device and is supplied by an external 5.5V to 25V  $V_{CC}$  supply. The 5V output is used by the XRP9710/1 as a standby power supply and supply power to the 5V gate drivers. The total output current that the 5V LDO can provide is 130mA. The XRP9710/1 consumes

approximately 20mA and the rest is the gate drive currents. *During initial power up, the maximum external load should be limited to 30mA.*

For operation with a  $V_{CC}$  of 4.75V to 5.5V, the LDO5 output needs to be connected directly to  $V_{CC}$  on the board.

### CLOCKS AND TIMING

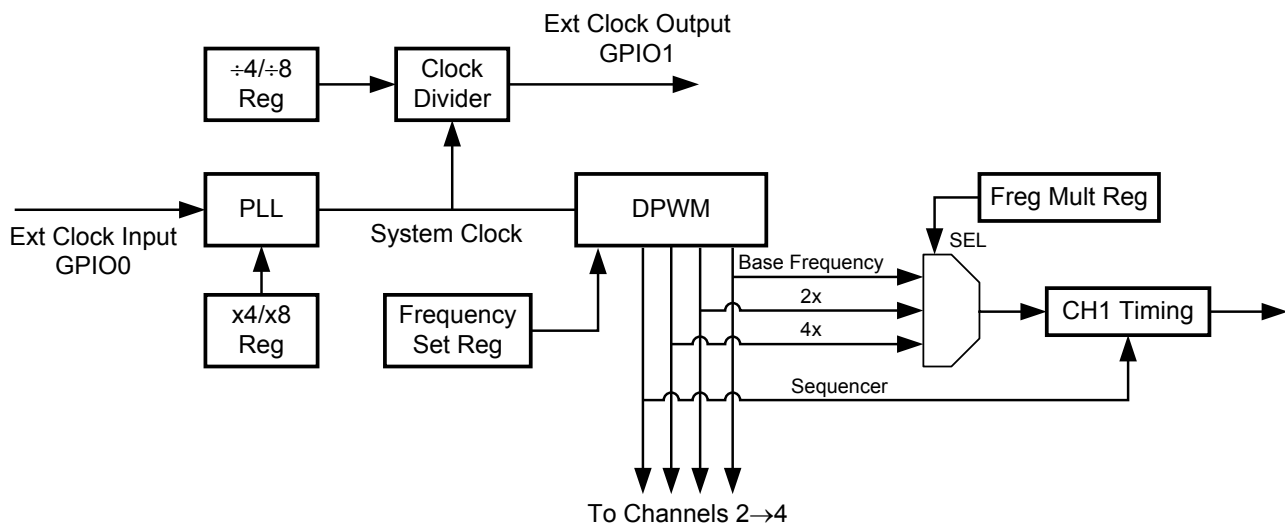

Figure 24 XRP9710 Timing Block Diagram

Figure 24 shows a simplified block diagram of the XRP9710/1 timing. Again, please note that the function blocks and signal names used are chosen for ease of understanding and do not necessarily reflect the actual design.

The system timing is generated by a 103MHz internal system clock (Sys\_Clk). There are two ways that the 103MHz system clock can be generated. These include an internal oscillator and a Phase Locked Loop (PLL) that is synchronized to an external clock input. The basic timing architecture is to divide the Sys\_Clk down to create a fundamental switching frequency (Fsw\_Fund) for all the output channels that is settable from 124kHz to 306kHz. The switching frequency for a channel (Fsw\_CHx) can then be selected as 1 time, 2 times or 4 times the fundamental switching frequency.

To set the base frequency for the output channels, an "Fsw\_Set" value representing the base frequency shown in Table 1, is entered into the switching frequency configuration register. Note that Fsw\_Set value is basically equal to the Sys\_Clk divided by the base frequency. The system timing is then created by dividing down Sys\_Clk to produce a base frequency clock, 2X and 4X times the base frequency clocks, and sequencing timing to position the output channels relative to each other. Each output channel then has its own frequency multiplier register that is used to select its final output switching frequency.

Table 1 shows the available channel switching frequencies for the XRP9710/1 device. The shaded areas show the allowable frequencies of the internal power stages. In practice the PowerArchitect™ 5.1 (PA 5.1) design tool



A New Direction in Mixed-Signal

# XRP9710 and XRP9711

## Dual 6A Programmable Power Module

---

handles all the details and the user only has to enter the fundamental switching frequency and the 1x, 2x, 4x frequency multiplier for each channel.

If an external clock is used, the frequencies in this table will shift accordingly.

| Base Frequency kHz | Available 2x Frequencies kHz | Available 4x Frequencies kHz |
|--------------------|------------------------------|------------------------------|
| 123.8              | 247.6                        | 495.2                        |
| 126.2              | 252.5                        | 504.9                        |
| 128.8              | 257.5                        | 515.0                        |
| 131.4              | 262.8                        | 525.5                        |
| 134.1              | 268.2                        | 536.5                        |
| 137.0              | 273.9                        | 547.9                        |
| 139.9              | 279.9                        | 559.8                        |
| 143.1              | 286.1                        | 572.2                        |
| 146.3              | 292.6                        | 585.2                        |
| 149.7              | 299.4                        | 598.8                        |
| 153.3              | 306.5                        | 613.1                        |
| 157.0              | 314.0                        | 628.0                        |
| 160.9              | 321.9                        | 643.8                        |
| 165.1              | 330.1                        | 660.3                        |
| 169.4              | 338.8                        | 677.6                        |
| 174.0              | 348.0                        | 695.9                        |
| 178.8              | 357.6                        | 715.3                        |
| 183.9              | 367.9                        | 735.7                        |
| 189.3              | 378.7                        | 757.4                        |
| 247.6              | 495.2                        | 990.4                        |
| 257.5              | 515.0                        | 1030.0                       |
| 268.2              | 536.5                        | 1072.9                       |
| 279.9              | 559.8                        | 1119.6                       |
| 292.6              | 585.2                        | 1170.5                       |
| 306.5              | 613.1                        | 1226.2                       |

Table 1



### SUPERVISORY AND CONTROL

Power system design with XRP9710/1 is accomplished using PA 5.1 design tool. All figures referenced in the following sections are taken from PA 5.1. Furthermore, the following sections reference I<sup>2</sup>C commands. For more information on these commands, refer to ANP-38. XRP9710/1 is supported with the commands listed in ANP-38 with the exception of XRP9710 using only the channel 3 and 4 related commands.

### DIGITAL I/O

XRP9710/1 has two General Purpose Input Output (GPIO) and three Power System Input Output (PSIO) user configurable pins.

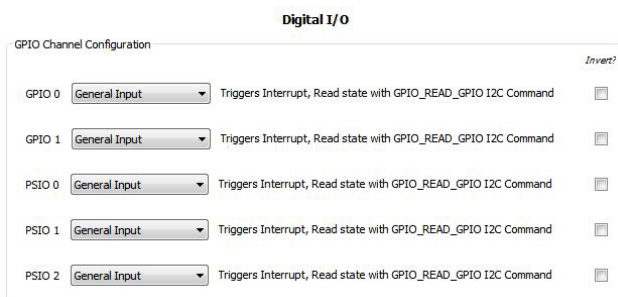

- GPIOs are 3.3V CMOS logic compatible and 5V tolerant.
- PSIOs which configured as outputs are open drain and require external pull-up resistors. These I/Os are 3.3V and 5V CMOS logic compatible, and up to 15V capable.

The polarity of the GPIO/PSIO pins is set in PA 5.1 or with an I<sup>2</sup>C command.

### Configuring GPIO/PSIOs

The following functions can be controlled from or forwarded to any GPIO/PSIO:

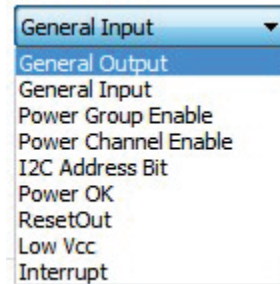

- **General Output** – set with an I<sup>2</sup>C command
- **General Input** – triggers an interrupt; state read with an I<sup>2</sup>C command
- **Power Group Enable** – controls enabling and disabling of Group 1 and Group 2.
- **Power Channel Enable** – controls enabling and disabling of an individual channel.
- **I<sup>2</sup>C Address Bit** – controls an I<sup>2</sup>C address bit.
- **Power OK** – indicates that selected channels have reached their target levels and have not faulted. Multiple channel selection is available, in which case the resulting signal is the AND logic function of all channels selected.
- **ResetOut** – is delayed Power OK. Delay is programmable in 1msec increments with the range of 0 to 255 msecs.
- **Low Vcc** – indicates when Vcc has fallen below the UVLO fault threshold and when the UVLO condition clears (Vcc voltage rises above the UVLO warning level).
- **Interrupt** – the controller generated interrupt selection and clearing is done through I<sup>2</sup>C commands.

Interrupt, Low Vcc, Power OK and ResetOut signals can only be forwarded to a single GPIO/PSIO.

In addition, the following are functions that are unique to GPIO0 and GPIO1.



A New Direction in Mixed-Signal

# XRP9710 and XRP9711

## Dual 6A Programmable Power Module

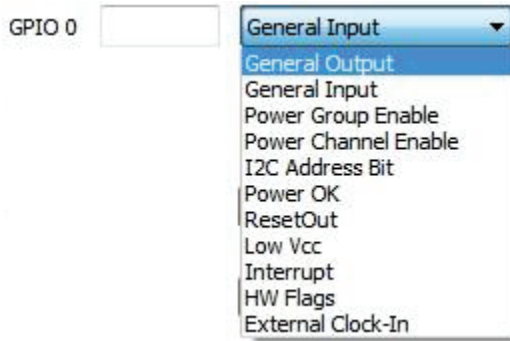

voltage against its user defined Power Good threshold limits (Power Good minimum and maximum levels). It has no hysteresis. Multiple channel selections will be combined using the AND logic function of all channels selected.



The Power Good minimum and maximum levels are expressed as percentages of the target voltage.

- **HW Flags** – these are hardware monitoring functions forwarded to GPIO0 only. The functions include Under-Voltage Warning, Over-Temperature Warning, Over-Voltage Fault, Over-Current Fault and Over-Current Warning for every channel. Multiple selections will be combined using the OR logic function.

PGood Max (%)

PGood Min (%)

“PGood Max” is the upper window and “PGood Min” is the lower window. The minimum and maximum for each of these values can be calculated with the following equation:

$$PGOOD(\%) = \frac{N * LSB(mV) * 10^5}{Vtarget (V)}$$

Where N=1 to 63 for the PGOOD Max value and N=1 to 62 for the PGOOD Min value. For example, with the target voltage of 1.5V and set point resolution of 2.5mV (LSB), the Power Good min and max values can range from 0.17% to 10.3% and 0.17% to 10.5% respectively. A user can effectively double the range by changing to the next higher output voltage range setting, but at the expense of reduced set point resolution.



- **External Clock-in** – enables the controller to lock to an external clock including one from another XRP9710/1 applied to the GPIO0 pin. There are two ranges of clock frequencies the controller accepts, selectable by a user.

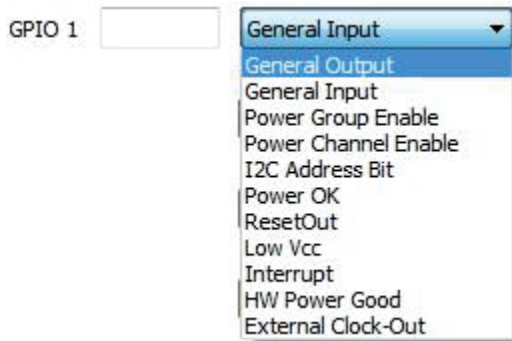

- **External Clock-out** – clock sent out through GPIO1 for synchronizing with another XRP9710/1 (see the clock out section for more information).

### FAULT HANDLING

There are six different types of fault handling:

- **HW Power Good** – the Power Good hardware monitoring function. It can only be forwarded to GPIO1. This is an output voltage monitoring function that is a hardware comparison of channel output

- **Under Voltage Lockout (UVLO)** monitors voltage supplied to the Vcc pin and will cause the controller to shut down



## Dual 6A Programmable Power Module

all channels if the supply drops to critical levels.

- **Over Temperature Protection (OTP)** monitors temperature of the chip and will cause the controller to shut down all channels if temperature rises to critical levels.
- **Over Voltage Protection (OVP)** monitors regulated voltage of a channel and will cause the controller to react in a user specified way if the regulated voltage surpasses threshold level.
- **Over Current Protection (OCP)** monitors current of a channel and will cause the controller to react in a user specified way if the current level surpasses threshold level.
- **Start-up Time-out Fault** monitors whether a channel gets into regulation in a user defined time period
- **LDO5 Over Current Protection (LDO5 OCP)** monitors current drawn from the regulator and will cause the controller to be reset if the current exceeds LDO5 limit

### UVLO

Both UVLO warning and fault levels are user programmable and set at 200mV increments in PA 5.1.

UVLO Warning (V)       UVLO Fault (V)

When the warning level is reached the controller will generate the UVLO\_WARNING\_EVENT interrupt. In addition, the host can be informed about the event through HW Flags on GPIO0 (see the Digital I/O section).

When an under voltage fault condition occurs, the XRP9710/1 outputs are shut down and the UVLO\_FAULT\_ACTIVE\_EVENT interrupt is generated. In addition, the host can be informed by forwarding the Low Vcc signal to any GPIO/PSIO (see the Digital I/O section). This signal transitions when the UVLO fault occurs. When coming out of the fault, rising Vcc crossing the UVLO fault level will trigger the UVLO\_FAULT\_INACTIVE\_EVENT interrupt.

Once the UVLO condition clears (Vcc voltage rises above or to the user-defined UVLO

warning level), the Low Vcc signal will transition and the controller will be reset.

Special attention needs to be paid in the case when Vcc = LDO5 = 4.75V to 5.5V. Since the input voltage ADC resolution is 200mV, the UVLO warning and fault set points are coarse for a 5V input. Therefore, setting the warning level at 4.8V and the fault level at 4.6V may result in the outputs not being re-enabled until a full 5.0V is reached on Vcc. Setting the warning level to 4.6V and the fault level at 4.4V would likely make UVLO handling as desired; however, at a fault level below 4.6V the device has a hardware UVLO on LDO5 to ensure proper shutdown of the internal circuitry of the controller. This means the 4.4V UVLO fault level may never occur.

### OTP

User defined OTP warning, fault and restart levels are set at 5°C increments in PA 5.1.

OTP Warning (°C)       OTP Fault (°C)   
 Enable Temp. Monitoring in Standby Mode       OTP Restart Threshold (°C)

When the warning level is reached the controller will generate the TEMP\_WARNING\_EVENT interrupt. In addition, the host can be informed about the event through HW Flags on GPIO0 (see the Digital I/O section).

When an OTP fault condition occurs, the XRP9710/1 outputs are shut down and the TEMP\_OVER\_EVENT interrupt is generated.

Once temperature reaches a user defined OTP Restart Threshold level, the TEMP\_UNDER\_EVENT interrupt will be generated and the controller will reset.

### OVP

A user defined OVP fault level is set in PA 5.1 and is expressed in percentages of a regulated target voltage.

OVP (%)

Resolution is the same as for the target voltage (expressed in percentages). The OVP minimum and maximum values are calculated



A New Direction in Mixed-Signal

# XRP9710 and XRP9711

## Dual 6A Programmable Power Module

by the following equation where the range for N is 1 to 63:

$$OVP(\%) = \frac{N * LSB(mV) * 10^5}{V_{target}(V)}$$

When the OVP level is reached and the fault is generated, the host will be notified by the SUPPLY\_FAULT\_EVENT interrupt generated by the controller. The host then can use an I<sup>2</sup>C command to check which channel is at fault.

In addition, OVP fault can be monitored through GPIO0.

A user can choose one of three options in response to an OVP event: shutdown the faulting channel, shut down faulting channel and perform auto-restart of the channel, or restart the chip.

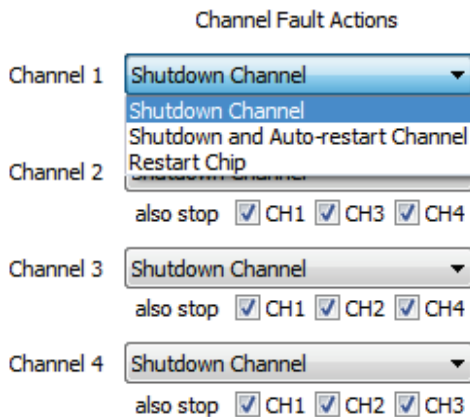

In the case of shutting down the faulting channel and auto-restarting, the user has an option to specify startup timeout (the time in which the fault is validated) and hiccup timeout (the period after which the controller will try to restart the channel) periods in 1 msec increments with a maximum value of 255 msec.

| Startup Timeout (ms) | Hiccup Timeout (ms) |
|----------------------|---------------------|
| 100                  | 100                 |
| 100                  | 100                 |
| 100                  | 100                 |
| 100                  | 100                 |

Note: The Channel Fault Action response is the same for an OVP or OCP event.

### OCP

A user defined OCP fault level is set with 10 mA increments in PA 5.1. PA 5.1 uses calculations to give the user the approximate DC output current entered in the current limit field. However the actual current limit trip value programmed into the part is limited to 280mV as defined in the electrical characteristics. The maximum value the user can program is limited by R<sub>ds(on)</sub> of the synchronous Power FET and current monitoring ADC range. For example, using a synchronous FET with R<sub>DS(ON)</sub> of 30mΩ, and the wider ADC range, the maximum current limit programmed would be:

$$OCP\ Max(A) = \frac{280mV}{30m\Omega} = 9.33A$$

The current is sampled approximately 30ns before the low side MOSFET turns off, so the actual measured DC output current in this example would be 9.33A plus approximately half the inductor ripple.

An OCP Fault is considered to have occurred only if the fault threshold has been tripped in four consecutive switching cycles. When the switching frequency is set to the 4x multiplier, the current is sampled only every other cycle. As a result it can take as many as eight switching cycles for an over current event to

be detected. When operating in 4x mode an inductor with a soft saturation characteristic is recommended.

When the OCP level is reached and the fault is generated, the host will be notified by the SUPPLY\_FAULT\_EVENT interrupt generated by the controller. The host then can use an I<sup>2</sup>C command to check which channel is at fault.

In addition, OCP faults can be monitored through HW Flags on GPIO0. The host can also monitor the OCP warning flag through HW Flags on GPIO0. The OCP warning level is calculated by PA 5.1 as 85% of the OCP fault level.

A user can choose one of three options in response to an OCP event: shutdown the faulting channel, shut down faulting channel and perform auto-restart of the channel, or restart the chip.

The output current reported by the XRP9710/1 is processed through a seven sample median filter in order to reduce noise. The OCP limit is compared against unfiltered ADC output.

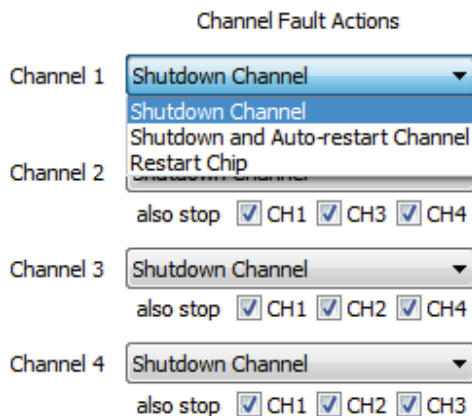

For the case of Shutdown and Auto-restart Channel, the user has an option to specify startup timeout (the time in which the fault is validated) and hiccup timeout (the period after which the controller will try to restart the channel) periods in 1 msec increments with a maximum value of 255 msec.

Note: The Channel Fault Action response is the same for an OVP or OCP event.

### Start-up Time-out Fault

A channel will be at Startup Timeout Fault if it does not come-up in the time period specified in the "Startup Timeout" box. In addition, a channel is at Startup Timeout Fault if its pre-bias configuration voltage is within a defined value too close to the target.

When the fault is generated, the host will be notified by the SUPPLY\_FAULT\_EVENT interrupt generated by the controller. The host then can use an I<sup>2</sup>C command to check which channel is at fault.

### LDO5 OCP

When current is drawn from the LDO5 that exceeds the LDO5 current limit the controller will be reset.

### EXTERNAL CLOCK SYNCHRONIZATION

XRP9710/1 can be run off an external clock available in the system or another XRP9710/1. The external clock must be in the ranges of 10.9MHz to 14.7MHz or 21.8MHz to 29.6MHz. Locking to the external clock is done through an internal Phase Lock Loop (PLL).

The external clock must be routed to GPIO0. The GPIO0 setting must reflect the range of the external clock applied to it: Sys\_Clock/8 corresponds to the range of 10.9MHz to 14.7MHz while Sys\_Clock/4 setting corresponds to the range of 21.8MHz to 29.6MHz.

The functionality is enabled in PA 5.1 by selecting External Clock-in function under GPIO0.



For more details on how to monitor PLL lock in-out, please contact Exar or your local Exar representative.

### CLOCK OUT

XRP9710/1 can supply clock out to be used by another XRP9710/1 controller. The clock is routed out through GPIO1 and can be set to system clock divided by 8 (Sys\_Clock/8) or system clock divided by 4 (Sys\_Clock/4) frequencies.

The functionality is enabled in PA 5.1 by selecting External Clock-Out function under GPIO1.



### CHANNEL CONTROL

Channels can be controlled independently by any GPIO/PSIO or I<sup>2</sup>C command. Channels will start-up or shut-down following transitions of signals applied to GPIO/PSIOs set to control the channels. The control can always be overridden with an I<sup>2</sup>C command.

Regardless of whether the channels are controlled independently or are in a group, the ramp rates will be followed as specified (see the Power Sequencing section).

Regulated voltages and voltage drops across the synchronous FET on each switching channel can be read back using I<sup>2</sup>C commands. The regulated voltage read back resolution is 15mV, 30mV and 60mV per LSB depending on the target voltage range. The voltage drop across synchronous FET read back resolution is 1.25mV and 2.5mV per LSB depending on the range.

Through an I<sup>2</sup>C command the host can check the status of the channels; whether they are in regulation or at fault.

Regulated voltages can be dynamically changed on switching channels using I<sup>2</sup>C commands with resolution of 2.5mV, 5mV and 10mV depending on the target voltage range (in PWM mode only).

For more information on I<sup>2</sup>C commands please refer to ANP-38 or contact Exar or your local Exar representative.

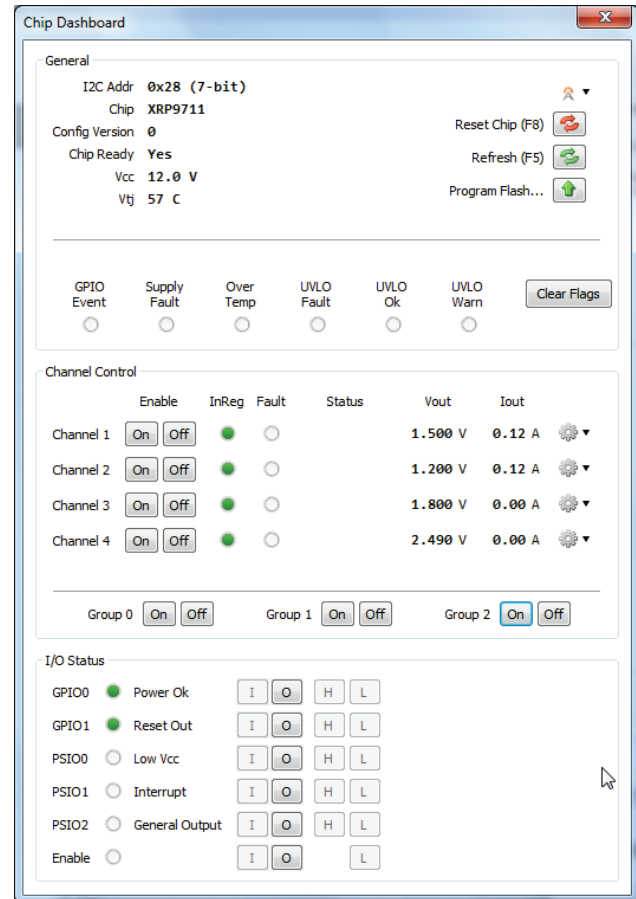

### POWER SEQUENCING

All channels can be grouped together and will start-up and shut-down in a user defined sequence.

Selecting none means the channel will not be assigned to any group and therefore will be controlled independently.

#### Group Selection

| Power Enable Groups | None                  | Group 0<br>(@ Chip Enable) | Group 1                          | Group 2                          |
|---------------------|-----------------------|----------------------------|----------------------------------|----------------------------------|
| Channel 1           | <input type="radio"/> | <input type="radio"/>      | <input checked="" type="radio"/> | <input type="radio"/>            |
| Channel 2           | <input type="radio"/> | <input type="radio"/>      | <input checked="" type="radio"/> | <input type="radio"/>            |
| Channel 3           | <input type="radio"/> | <input type="radio"/>      | <input checked="" type="radio"/> | <input type="radio"/>            |
| Channel 4           | <input type="radio"/> | <input type="radio"/>      | <input type="radio"/>            | <input checked="" type="radio"/> |

There are three groups:

- **Group 0** – is controlled by the chip ENABLE or an I<sup>2</sup>C command. Channels assigned to this group will come up with the ENABLE signal being high (plus additional delay needed to load configuration from Flash to run-time



A New Direction in Mixed-Signal

# XRP9710 and XRP9711

## Dual 6A Programmable Power Module

registers), and will go down with the ENABLE signal being low. The control can always be overridden with an I<sup>2</sup>C command.

Since it is recommended to leave the ENABLE pin floating in the applications when Vcc = LDO5 = 4.75V to 5.5V, please contact Exar for how to configure the channels to come up at the power up in this scenario.

- **Group 1** – can be controlled by any GPIO/PSIO or I<sup>2</sup>C command. Channels assigned to this group will start-up or shut-down following transitions of a signal applied to the GPIO/PSIO set to control the group. The control can always be overridden with an I<sup>2</sup>C command.
- **Group 2** – can be controlled by any GPIO/PSIO or I<sup>2</sup>C command. Channels assigned to this group will start-up or shut-down following transitions of a signal applied to the GPIO/PSIO set to control the group. The control can always be overridden with an I<sup>2</sup>C command.

### Start-up

| Start-up  |                  |        |                          | Group 0    |        |                          | Group 1    |        |                          | Group 2    |  |  |
|-----------|------------------|--------|--------------------------|------------|--------|--------------------------|------------|--------|--------------------------|------------|--|--|
| Channel   | Ramp Rate (ms/V) | Order  | Wait                     | Delay (ms) | Order  | Wait                     | Delay (ms) | Order  | Wait                     | Delay (ms) |  |  |
|           |                  | PGOOD? | PGOOD?                   | PGOOD?     | PGOOD? | PGOOD?                   | PGOOD?     | PGOOD? | PGOOD?                   | PGOOD?     |  |  |
| Channel 1 | 4.858            | 0      | <input type="checkbox"/> | 0          | 1      | <input type="checkbox"/> | 0          | 0      | <input type="checkbox"/> | 0          |  |  |
| Channel 2 | 4.858            | 0      | <input type="checkbox"/> | 0          | 2      | <input type="checkbox"/> | 0          | 0      | <input type="checkbox"/> | 0          |  |  |
| Channel 3 | 5.020            | 0      | <input type="checkbox"/> | 0          | 0      | <input type="checkbox"/> | 0          | 1      | <input type="checkbox"/> | 0          |  |  |
| Channel 4 | 5.020            | 0      | <input type="checkbox"/> | 0          | 0      | <input type="checkbox"/> | 0          | 2      | <input type="checkbox"/> | 0          |  |  |

For each channel within a group, a user can specify the following start-up characteristics:

- **Ramp Rate** – expressed in milliseconds per volt.
- **Order** – position of a channel to come-up within the group
- **Wait PGOOD?** – selecting this option for a channel means the next channel in the order will not start ramping-up until this channel reaches the target level and its Power Good flag is asserted.
- **Delay** – an additional time delay a user can specify to postpone a channel start-up with respect to the previous channel in the order. The delay is expressed in milliseconds with a range of 0msec to 255msec.

### Shut-down

| Shutdown  |                  |             |                          | Group 0     |             |                          | Group 1     |             |                          | Group 2     |  |  |
|-----------|------------------|-------------|--------------------------|-------------|-------------|--------------------------|-------------|-------------|--------------------------|-------------|--|--|
| Channel   | Ramp Rate (ms/V) | Order       | Wait                     | Delay (ms)  | Order       | Wait                     | Delay (ms)  | Order       | Wait                     | Delay (ms)  |  |  |
|           |                  | StopThresh? | StopThresh?              | StopThresh? | StopThresh? | StopThresh?              | StopThresh? | StopThresh? | StopThresh?              | StopThresh? |  |  |
| Channel 1 | 4.858            | 0           | <input type="checkbox"/> | 0           | 1           | <input type="checkbox"/> | 0           | 0           | <input type="checkbox"/> | 0           |  |  |
| Channel 2 | 4.858            | 0           | <input type="checkbox"/> | 0           | 2           | <input type="checkbox"/> | 0           | 0           | <input type="checkbox"/> | 0           |  |  |
| Channel 3 | 5.020            | 0           | <input type="checkbox"/> | 0           | 0           | <input type="checkbox"/> | 0           | 1           | <input type="checkbox"/> | 0           |  |  |
| Channel 4 | 5.020            | 0           | <input type="checkbox"/> | 0           | 0           | <input type="checkbox"/> | 0           | 2           | <input type="checkbox"/> | 0           |  |  |

For each channel within a group a user can specify the following shut-down characteristics:

- **Ramp Rate** – expressed in milliseconds per volt.
- **Order** – position of a channel to come-down within the group
- **Wait Stop Thresh?** – selecting this option for a channel means the next channel in the order will not start ramping-down until this channel reaches the Stop Threshold level. The stop threshold level is fixed at 600mV.
- **Delay** – additional time delay a user can specify to postpone a channel shut-down with respect to the previous channel in the order. The delay is expressed in milliseconds with a range of 0msec to 255msec.

### MONITORING VCC AND TEMPERATURE

Through I<sup>2</sup>C commands, the host can read back the voltage applied to the Vcc pin and the die temperature respectively. The Vcc read back resolution is 200mV per LSB; the die temperature read back resolution is 5C° per LSB. For more on I<sup>2</sup>C commands please refer to ANP-38.

### PROGRAMMING XRP9710/1

XRP9710/1 is a FLASH based device which means its configuration can be programmed into FLASH NVM and re-programmed a number of times.

Programming of FLASH NVM is done through PA 5.1.



A New Direction in Mixed-Signal

# XRP9710 and XRP9711

## Dual 6A Programmable Power Module

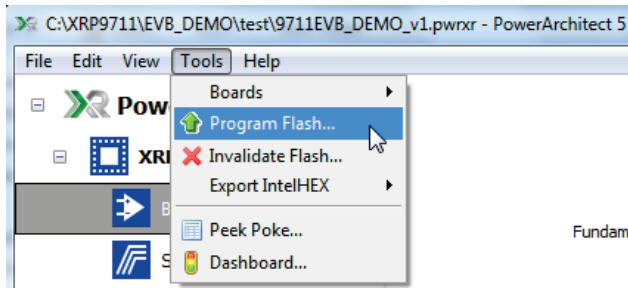

### XRP9710

The XRP9710 differs from the XRP9711 in that it eliminates the two external power stages but adds differential voltage sensing of the two remaining outputs. However, the two remaining channels remain designated 3 and 4. Below in the PA 5.1 Dashboard, one can see Channels 1 and 2 grayed out when using a XRP9710. This methodology also ensures code development is easily ported between the two devices.

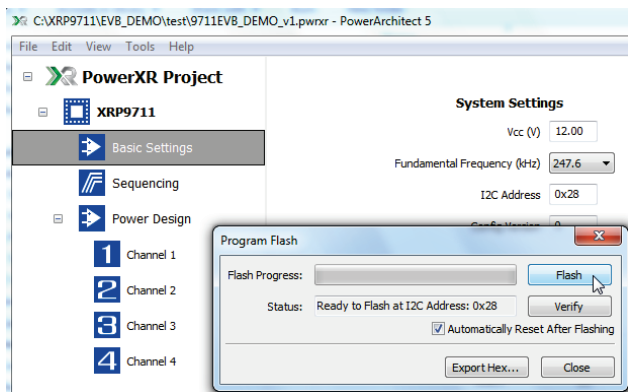

By clicking on the Flash button, the user will start the programming sequence of the design configuration into the Flash NVM. After the programming sequence completes, the chip will reset (if automatically reset After Flashing box is checked) and boot the design configuration from the Flash.

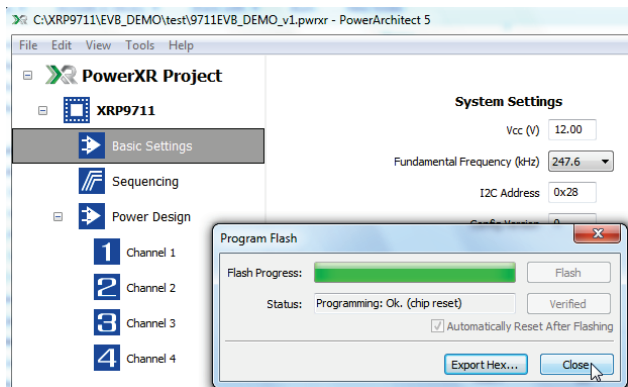

Chip Dashboard

General

I2C Addr 0x28 (7-bit)  
 Chip XRP9710  
 Config Version 0  
 Chip Ready Yes  
 Vcc 13.2 V  
 Vtj 37 C

Reset Chip (F8)  
 Refresh (F5)  
 Program Flash...

GPIO Event  
 Supply Fault  
 Over Temp  
 UVLO Fault  
 UVLO Ok  
 UVLO Warn

Clear Flags

Channel Control

| Channel   | Enable | InReg | Fault                            | Status                | Vout    | Iout   |
|-----------|--------|-------|----------------------------------|-----------------------|---------|--------|
| Channel 1 | On     | Off   | <input type="radio"/>            | <input type="radio"/> | 0.015 V | 0.00 A |
| Channel 2 | On     | Off   | <input type="radio"/>            | <input type="radio"/> | 0.000 V | 0.00 A |
| Channel 3 | On     | Off   | <input checked="" type="radio"/> | <input type="radio"/> | 1.800 V | 0.00 A |
| Channel 4 | On     | Off   | <input checked="" type="radio"/> | <input type="radio"/> | 2.490 V | 0.00 A |

Group 0 On Off    Group 1 On Off    Group 2 On Off

I/O Status

GPIO0  Power Ok    I O H L  
 GPIO1  Reset Out    I O H L  
 PSIO0  Low Vcc    I O H L  
 PSIO1  Interrupt    I O H L  
 PSIO2  General Output    I O H L  
 Enable I O L

Users who wish to create their own programming procedure so they can re-program Flash in-circuit using their system software should contact Exar for a list of needed I<sup>2</sup>C Flash Commands.



### ENABLING XRP9710/1

XRP9710/1 has a weak internal pull-up ensuring it becomes enabled as soon as internal voltage supplies have ramped up and are in regulation.

Driving the Enable pin low externally will keep the controller in the shut-down mode. A simple open drain pull down is the recommended way to shut XRP9710/1 down.

If the Enable pin is driven high externally to control XRP9710/1 coming out of the shut-down mode, care must be taken to ensure the Enable pin is driven high after Vcc gets supplied to the controller.

In the configuration when  $V_{cc} = LDO5 = 4.75V$  to  $5.5V$ , disabling the device by grounding the Enable pin is not recommended. It is recommended to leave the Enable pin floating and place the controller in the "Standby Mode" instead in this scenario. The standby mode is defined as the state when all switching channels are disabled, all GPIO/PSIOs are programmed as inputs, and the system clock is disabled. In this state the device consumes 440uA typically.

### Short duration Enable pin toggled low

Short duration shutdown pulses to the ENABLE pin of the XRP9710/1, which do not provide sufficient time for the LDO5 voltage to fall below 3.5V, can result in significant delay in re-enabling of the device. Some examples below show LDO5 and ENABLE pins:

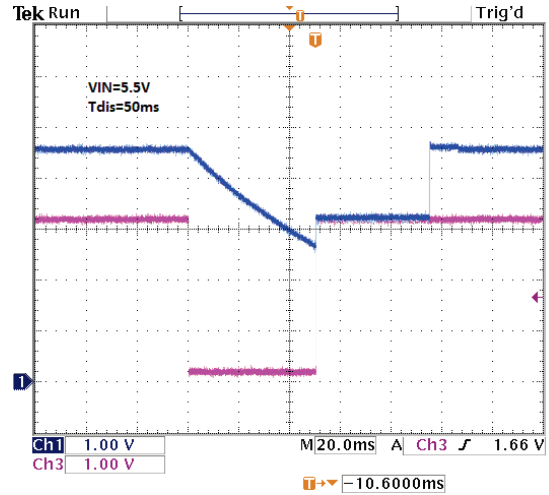

No load on LDO5, blue trace. Recovery time after the ENABLE logic high is approximately 40ms.

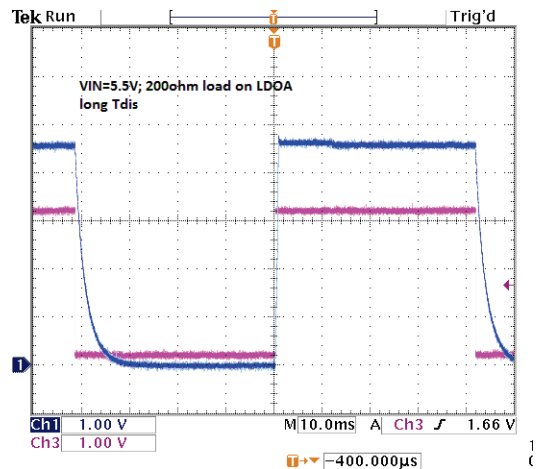

Adding a 200 ohm load on LDO5 pulls the voltage below 3.5V and the restart is short.

Note that as  $V_{CC}$  increases, the restart time falls as well. A 5.5V input voltage is shown as the worst case.

Since the ENABLE pin has an internal current source, a simple open drain pull down is the recommended way to shut down the XRP9710/1. A diode in series with a resistor between the LDO5 and ENABLE pins may offer a way to more quickly pull down the LDO5 output when the ENABLE pin is pulled low.

### APPLICATION INFORMATION

#### THERMAL DESIGN

Proper thermal design is critical in controlling device temperatures and in achieving robust designs. There are a number of factors that affect the thermal performance. One key factor is the temperature rise of the devices in the package, which is a function of the thermal resistances of the devices inside the package and the power being dissipated ( $P_{DISS}$ ).

The thermal resistance of the XRP9710/1 is shown in the "Operating Ratings" section of this datasheet. The JEDEC  $\theta_{JA}$  thermal resistance provided is based on tests that comply with the JESD51-2A "Integrated Circuit Thermal Test Method Environmental Conditions - Natural Convection" standard. JESD51-xx are a group of standards whose intent is to provide comparative data based on a standard test condition which includes a defined board construction. Since the actual board design in the final application will be different from the board defined in the standard, the thermal resistances in the final design may be different from those shown.

The package thermal derating curve is shown in Figure 18. The total package power dissipation ( $P_{PKG}$ ) is dependent on the final application design for channels three and four, and is the sum of the losses for the two channels. The power losses for a channel will depend mainly on the input voltage, output voltage, and output current. Figure 19 and Figure 20 show the power losses for input voltages of 5V and 12V respectively.

First, determine the package power derating for a maximum ambient temperature ( $T_{AMB}$ )

using Figure 18. Then, based on the design input voltage, use Figures 19 or 20 accordingly.

For example:

Consider a two channel design that has a  $T_{AMB} = 50^{\circ}\text{C}$ ,  $V_{IN} = 12\text{V}$ ,  $V_{OUT3} = 1\text{V}$ ,  $V_{OUT4} = 3.3\text{V}$ . Figure 18 shows  $P_{PKG}$  max is 4.1 Watts at  $50^{\circ}\text{C}$ . The result is that the sum of the power dissipation for both channels must be less than the 4.1W.

Figure 20 shows the power dissipation for  $V_{IN} = 12\text{V}$  designs. If the 1V output current is 6A, then its  $P_{DISS}$  is 2.1W. This leaves 2W for the 3.3V channel. The graph shows that at 2W the maximum 3.3V output current would be 4.7A.

#### EMI EMISSIONS

The XRP9711 has been tested on the evaluation board and passes CISPR22 Level B radiated emissions.

#### LAYOUT GUIDELINES

Refer to application note ANP-32 "Practical Layout Guidelines for Power<sup>XR</sup> Designs". These apply primarily to the two external power stages available on the XRP9711.

Also refer to the XRP9710 or XRP9711 Evaluation Board Manual for specifics in grounding and heat sinking.

#### BOARD ASSEMBLY

Detailed boards assembly information specifically to address the unique package requirement is available in ANP-45, LGA Module Assembly Application Note.



A New Direction in Mixed-Signal

# XRP9710 and XRP9711

## Dual 6A Programmable Power Module

### PACKAGE SPECIFICATION

### 12MMX12MM LGA

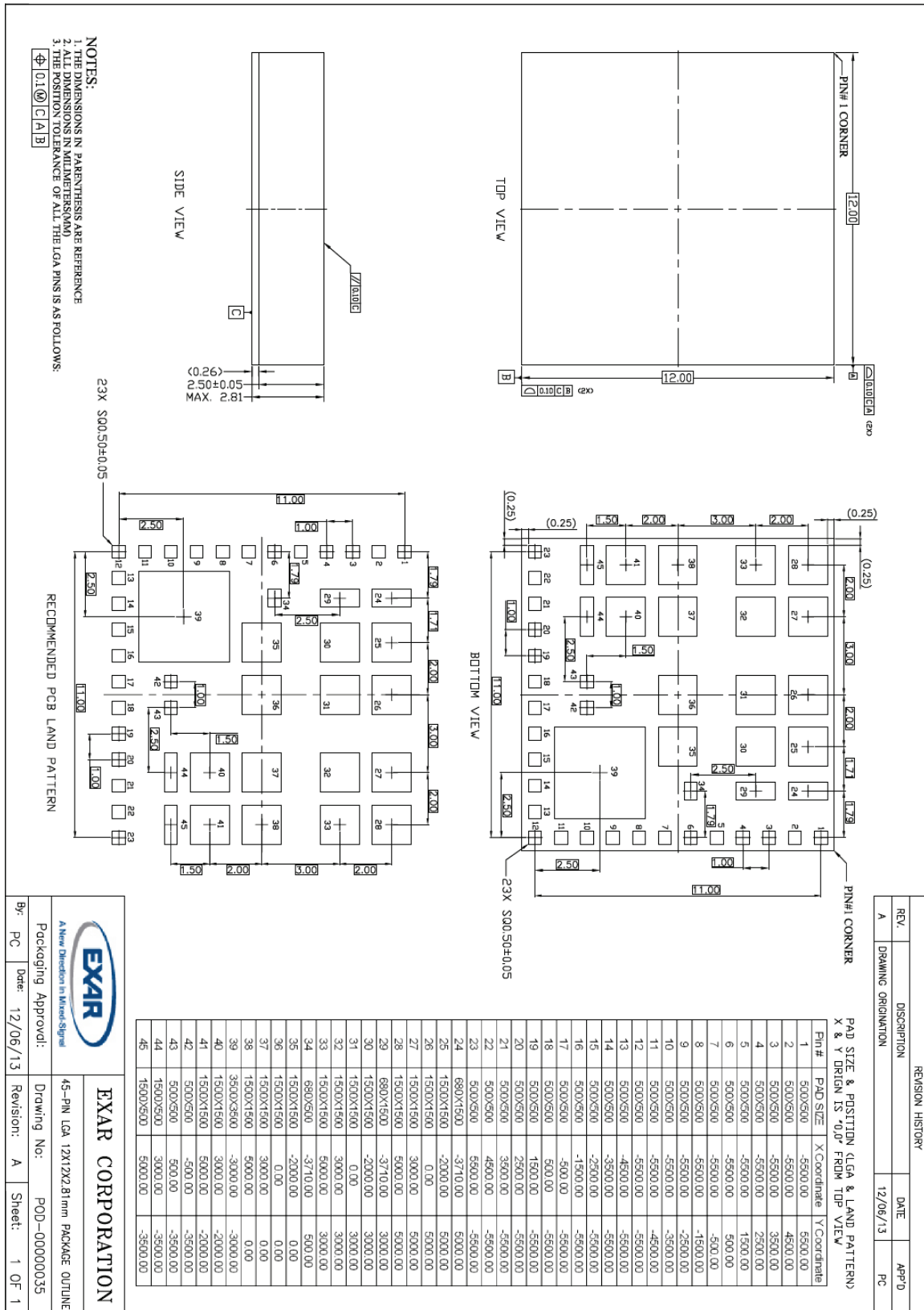



# XRP9710 and XRP9711

## Dual 6A Programmable Power Module

### REVISION HISTORY

| Revision | Date       | Description   |
|----------|------------|---|
| 1.0.0    | 12/18/2013 | Initial Release [ECN: 1352-06]  |
| 1.0.1    | 01/03/2014 | Fix minor typographical items for consistency. Formatting updates. [ECN: 1402-03] |
| 1.0.2    | 01/14/2014 | Updated marking information in ordering table                                     |
|          |            |   |
|          |            |   |
|          |            |   |
|          |            |   |

### FOR FURTHER ASSISTANCE

Email:

[customersupport@exar.com](mailto:customersupport@exar.com)

[powertechsupport@exar.com](mailto:powertechsupport@exar.com)

Exar Technical Documentation:

<http://www.exar.com/TechDoc/default.aspx?>



### EXAR CORPORATION

#### HEADQUARTERS AND SALES OFFICES

48720 Kato Road

Fremont, CA 94538 – USA

Tel.: +1 (510) 668-7000

Fax: +1 (510) 668-7030

[www.exar.com](http://www.exar.com)

### NOTICE

EXAR Corporation reserves the right to make changes to the products contained in this publication in order to improve design, performance or reliability. EXAR Corporation assumes no responsibility for the use of any circuits described herein, conveys no license under any patent or other right, and makes no representation that the circuits are free of patent infringement. Charts and schedules contained herein are only for illustration purposes and may vary depending upon a user's specific application. While the information in this publication has been carefully checked; no responsibility, however, is assumed for inaccuracies.

EXAR Corporation does not recommend the use of any of its products in life support applications where the failure or malfunction of the product can reasonably be expected to cause failure of the life support system or to significantly affect its safety or effectiveness. Products are not authorized for use in such applications unless EXAR Corporation receives, in writing, assurances to its satisfaction that: (a) the risk of injury or damage has been minimized; (b) the user assumes all such risks; (c) potential liability of EXAR Corporation is adequately protected under the circumstances.

Reproduction, in part or whole, without the prior written consent of EXAR Corporation is prohibited.

Компания «Океан Электроники» предлагает заключение долгосрочных отношений при поставках импортных электронных компонентов на взаимовыгодных условиях!

Наши преимущества:

- Поставка оригинальных импортных электронных компонентов напрямую с производств Америки, Европы и Азии, а так же с крупнейших складов мира;
- Широкая линейка поставок активных и пассивных импортных электронных компонентов (более 30 млн. наименований);
- Поставка сложных, дефицитных, либо снятых с производства позиций;
- Оперативные сроки поставки под заказ (от 5 рабочих дней);
- Экспресс доставка в любую точку России;
- Помощь Конструкторского Отдела и консультации квалифицированных инженеров;
- Техническая поддержка проекта, помощь в подборе аналогов, поставка прототипов;
- Поставка электронных компонентов под контролем ВП;
- Система менеджмента качества сертифицирована по Международному стандарту ISO 9001;
- При необходимости вся продукция военного и аэрокосмического назначения проходит испытания и сертификацию в лаборатории (по согласованию с заказчиком);
- Поставка специализированных компонентов военного и аэрокосмического уровня качества (Xilinx, Altera, Analog Devices, Intersil, Interpoint, Microsemi, Actel, Aeroflex, Peregrine, VPT, Syfer, Eurofarad, Texas Instruments, MS Kennedy, Miteq, Cobham, E2V, MA-COM, Hittite, Mini-Circuits, General Dynamics и др.);

Компания «Океан Электроники» является официальным дистрибьютором и эксклюзивным представителем в России одного из крупнейших производителей разъемов военного и аэрокосмического назначения «JONHON», а так же официальным дистрибьютором и эксклюзивным представителем в России производителя высокотехнологичных и надежных решений для передачи СВЧ сигналов «FORSTAR».



## JONHON

«JONHON» (основан в 1970 г.)

Разъемы специального, военного и аэрокосмического назначения:

(Применяются в военной, авиационной, аэрокосмической, морской, железнодорожной, горно- и нефтедобывающей отраслях промышленности)

«FORSTAR» (основан в 1998 г.)

ВЧ соединители, коаксиальные кабели, кабельные сборки и микроволновые компоненты:

(Применяются в телекоммуникациях гражданского и специального назначения, в средствах связи, РЛС, а так же военной, авиационной и аэрокосмической отраслях промышленности).



Телефон: 8 (812) 309-75-97 (многоканальный)

Факс: 8 (812) 320-03-32

Электронная почта: [ocean@oceanchips.ru](mailto:ocean@oceanchips.ru)

Web: <http://oceanchips.ru/>

Адрес: 198099, г. Санкт-Петербург, ул. Калинина, д. 2, корп. 4, лит. А