



Is Now Part of



ON Semiconductor®

To learn more about ON Semiconductor, please visit our website at
www.onsemi.com

Please note: As part of the Fairchild Semiconductor integration, some of the Fairchild orderable part numbers will need to change in order to meet ON Semiconductor's system requirements. Since the ON Semiconductor product management systems do not have the ability to manage part nomenclature that utilizes an underscore (_), the underscore (_) in the Fairchild part numbers will be changed to a dash (-). This document may contain device numbers with an underscore (_). Please check the ON Semiconductor website to verify the updated device numbers. The most current and up-to-date ordering information can be found at www.onsemi.com. Please email any questions regarding the system integration to Fairchild_questions@onsemi.com.

ON Semiconductor and the ON Semiconductor logo are trademarks of Semiconductor Components Industries, LLC dba ON Semiconductor or its subsidiaries in the United States and/or other countries. ON Semiconductor owns the rights to a number of patents, trademarks, copyrights, trade secrets, and other intellectual property. A listing of ON Semiconductor's product/patent coverage may be accessed at www.onsemi.com/site/pdf/Patent-Marking.pdf. ON Semiconductor reserves the right to make changes without further notice to any products herein. ON Semiconductor makes no warranty, representation or guarantee regarding the suitability of its products for any particular purpose, nor does ON Semiconductor assume any liability arising out of the application or use of any product or circuit, and specifically disclaims any and all liability, including without limitation special, consequential or incidental damages. Buyer is responsible for its products and applications using ON Semiconductor products, including compliance with all laws, regulations and safety requirements or standards, regardless of any support or applications information provided by ON Semiconductor. "Typical" parameters which may be provided in ON Semiconductor data sheets and/or specifications can and do vary in different applications and actual performance may vary over time. All operating parameters, including "Typicals" must be validated for each customer application by customer's technical experts. ON Semiconductor does not convey any license under its patent rights nor the rights of others. ON Semiconductor products are not designed, intended, or authorized for use as a critical component in life support systems or any FDA Class 3 medical devices or medical devices with a same or similar classification in a foreign jurisdiction or any devices intended for implantation in the human body. Should Buyer purchase or use ON Semiconductor products for any such unintended or unauthorized application, Buyer shall indemnify and hold ON Semiconductor and its officers, employees, subsidiaries, affiliates, and distributors harmless against all claims, costs, damages, and expenses, and reasonable attorney fees arising out of, directly or indirectly, any claim of personal injury or death associated with such unintended or unauthorized use, even if such claim alleges that ON Semiconductor was negligent regarding the design or manufacture of the part. ON Semiconductor is an Equal Opportunity/Affirmative Action Employer. This literature is subject to all applicable copyright laws and is not for resale in any manner.

MM74HCT14

Hex Inverting Schmitt Trigger

Features

- Typical Propagation Delay: 13ns
- Wide Power Supply Range: 4.5V–5.5V
- Low Quiescent Current: 10µA Maximum
- Low Input Current: 1µA Maximum
- Fanout of 10 LS-TTL Loads
- Typical Hysteresis Voltage: 0.6V at $V_{CC} = 4.5V$
- TTL, LS Pin-out and Input Threshold Compatible

Description

The MM74HCT14 utilizes advanced silicon-gate CMOS technology to achieve the low power dissipation and high noise immunity of standard CMOS, as well as the capability to drive 10 LS-TTL loads.

The 74HCT logic family is functionally and pinout-compatible with the standard 74LS logic family. Inputs are protected from damage due to static discharge by internal diode clamps to V_{CC} and ground.

Ordering Information

Part Number	Operating Temperature Range	 Eco Status	Package	Packing Method
MM74HCT14M	-40°C to +85°C	RoHS	14-Lead, Small-Outline Integrated Circuit (SOIC), JEDEC MS-012, 0.150in Narrow	Tube
MM74HCT14MX	-40°C to +85°C	RoHS	14-Lead, Small-Outline Integrated Circuit (SOIC), JEDEC MS-012, 0.150in Narrow	Tape & Reel
MM74HCT14SJ	-40°C to +85°C	RoHS	14-Lead, Small-Outline Package (SOP), EIAJ Type II, 5.3mm Wide	Tube
MM74HCT14SJX	-40°C to +85°C	RoHS	14-Lead, Small-Outline Package (SOP), EIAJ Type II, 5.3mm Wide	Tape & Reel
MM74HCT14MTC	-40°C to +85°C	RoHS	14-Lead, Thin-Shrink Small-Outline Package (TSSOP), JEDEC MO-153, 4.4mm Wide	Tube
MM74HCT14MTCX	-40°C to +85°C	RoHS	14-Lead, Thin-Shrink Small-Outline Package (TSSOP), JEDEC MO-153, 4.4mm Wide	Tape & Reel
MM74HCT14SN	-40°C to +85°C	RoHS	14-Lead, Plastic Dual-Inline Package (PDIP), JEDEC MS-001, 0.300in Wide	Tube

 For Fairchild's definition of Eco Status, please visit: http://www.fairchildsemi.com/company/green/rohs_green.html.

Connection Diagram

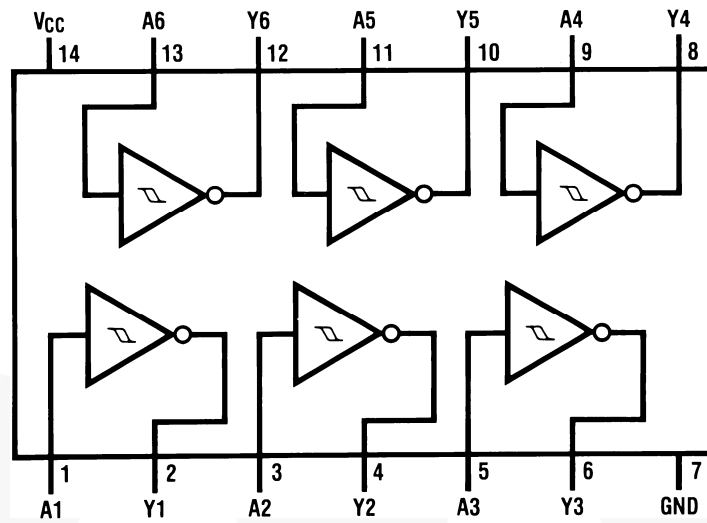

Figure 1. Pin Assignments

Schematic Diagram

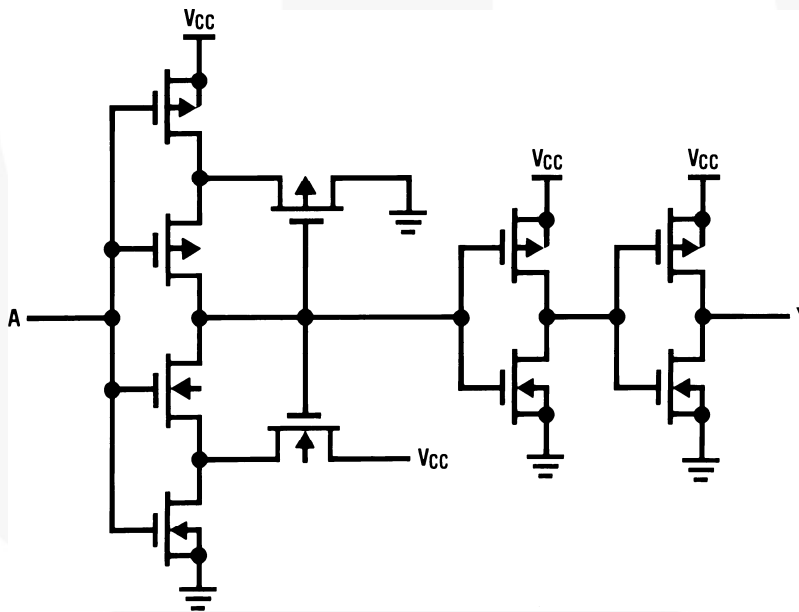

Figure 2. Schematic

Absolute Maximum Ratings

Stresses exceeding the absolute maximum ratings may damage the device. The device may not function or be operable above the recommended operating conditions and stressing the parts to these levels is not recommended. In addition, extended exposure to stresses above the recommended operating conditions may affect device reliability. The absolute maximum ratings are stress ratings only. Unless otherwise specified, all voltages are referenced to ground.

Symbol	Parameter	Min.	Max.	Unit
V_{CC}	Supply Voltage	-0.5	+7.0	V
V_{IN}	DC Input Voltage	-1.5	$V_{CC} + 1.5$	V
V_{OUT}	DC Output Voltage	-0.5	$V_{CC} + 0.5$	V
I_K, I_{OK}	Clamp Diode Current		± 20	mA
I_{OUT}	DC Output Current, Per Pin		± 25	mA
I_{CC}	DC V_{CC} or GND Current, Per Pin		± 50	mA
T_{STG}	Storage Temperature Range	-65	+150	°C
T_L	Lead Temperature (Soldering 10 Seconds)		+260	°C

Recommended Operating Conditions

The Recommended Operating Conditions table defines the conditions for actual device operation. Recommended operating conditions are specified to ensure optimal performance to the datasheet specifications. Fairchild does not recommend exceeding them or designing to Absolute Maximum Ratings.

Symbol	Parameter	Min.	Max.	Unit
V_{CC}	Supply Voltage	4.5	5.5	V
V_{IN}, V_{OUT}	DC Input or Output Voltage	0	V_{CC}	V
T_A	Operating Temperature Range	-40	+85	°C

DC Electrical Characteristics

Symbol	Parameter	Conditions	V _{CC}	T _A =+25°C		T _A =-40°C to +85°C	Units
				Typ.	Guaranteed Limits		
V _{T+}	Positive-Going Threshold Voltage	Minimum	4.5	1.5	1.2	1.2	V
			5.5	1.7	1.4	1.4	
		Maximum	4.5	1.5	1.9	1.9	
			5.5	1.7	2.1	2.1	
V _{T-}	Negative-Going Threshold Voltage	Minimum	4.5	0.9	0.5	0.5	V
			5.5	1.0	0.6	0.6	
		Maximum	4.5	0.9	1.2	1.2	
			5.5	1.0	1.4	1.4	
V _H	Hysteresis Voltage	Minimum	4.5	0.6	0.4	0.4	V
			5.5	0.7	0.4	0.4	
		Maximum	4.5	0.6	1.4	1.4	
			5.5	0.7	1.5	1.5	
V _{OH}	Minimum HIGH Level Output Voltage	V _{IN} = V _{IL} , I _{OUT} = 20μA	4.5	V _{CC}	V _{CC} - 0.1	V _{CC} - 0.1	V
		V _{IN} = V _{IL} , I _{OUT} = 4.0mA	4.5	4.20	3.98	3.84	
		V _{IN} = V _{IL} , I _{OUT} = 4.8mA	5.5	5.20	4.98	4.98	
V _{OL}	Maximum LOW Level Voltage	V _{IN} = V _{IL} , I _{OUT} = 20μA	4.5	0	0.1	0.1	V
		V _{IN} = V _{IL} , I _{OUT} = 4.0mA	4.5	0.2	0.26	0.33	
		V _{IN} = V _{IL} , I _{OUT} = 4.8mA	5.5	0.2	0.26	0.33	
I _{IN}	Maximum Input Current	V _{IN} = V _{CC} or GND, V _{IH} or V _{IL}	5.5		±0.1	±1.0	μA
I _{CC}	Maximum Quiescent Supply Current	V _{IN} = V _{CC} or GND, I _{OUT} = 0μA	5.5		1.0	10.0	μA
		V _{IN} = 2.4V or 0.5V			2.4	2.4	mA

AC Electrical Characteristics

$V_{CC} = 5V$, $T_A = 25^\circ C$, $C_L = 15pF$, $t_r = t_f = 6ns$.

Symbol	Parameter	Typ.	Guaranteed Limit	Unit
t_{PHL} , t_{PLH}	Maximum Propagation Delay	10	18	ns

AC Electrical Characteristics

Unless otherwise specified, $V_{CC} = 5V \pm 10\%$, $C_L = 50pF$, $t_r = t_f = 6ns$.

Symbol	Parameter	Conditions	$T_A = +25^\circ C$		$T_A = -40^\circ C$ to $+85^\circ C$	Units
			Typ.	Guaranteed Limits		
t_{PHL} , t_{PLH}	Maximum Propagation Delay			20	25	ns
t_{TLH} , t_{THL}	Maximum Output Rise and Fall Time		9	15	19	ns
C_{PD}	Power Dissipation Capacitance ⁽¹⁾	Per Gate		25		pF
C_{IN}	Maximum Input Capacitance		5	10	10	pF

Note:

- C_{PD} determines the no-load dynamic power consumption, $P_D = C_{PD} V_{CC}^2 f + I_{CC} V_{CC}$, and the no-load dynamic current consumption, $I_S = C_{PD} V_{CC} f + I_{CC}$.

Typical Applications

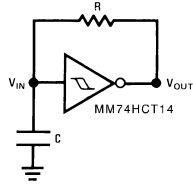

Figure 3. Low Power Oscillator

The following equations assume $t_1+t_2 \gg t_{pd0}+t_{pd1}$:

$$t_2 \approx RC \ln \frac{V_{CC} - V_{T-}}{V_{CC} - V_{T+}} \quad (1)$$

$$f \approx \frac{1}{RC \ln \frac{V_{T+}(V_{CC} - V_{T-})}{V_{T-}(V_{CC} - V_{T+})}} \quad (2)$$

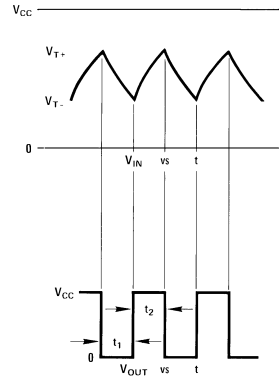
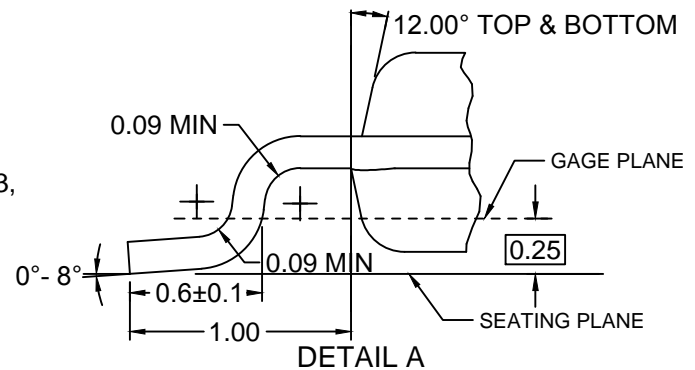
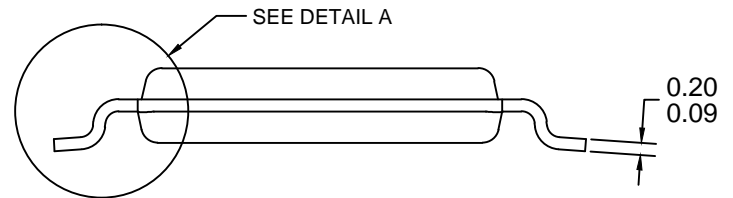
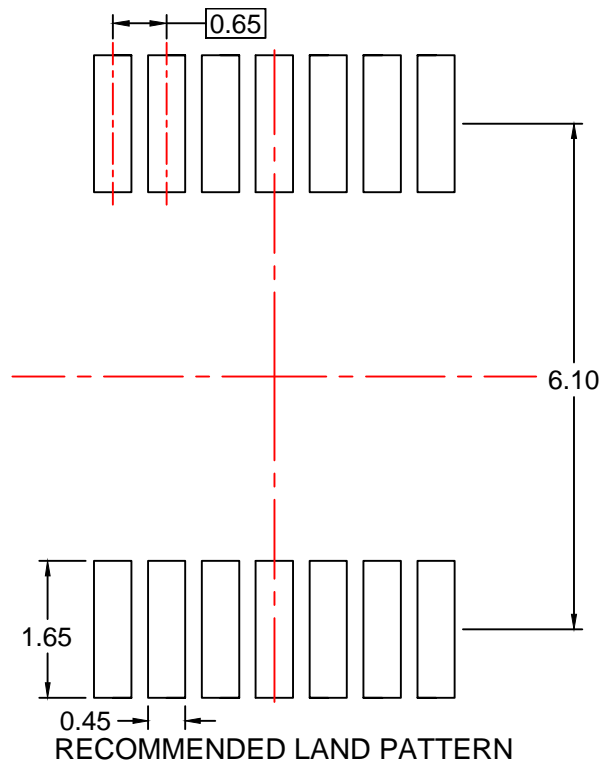

Figure 4. Oscillator Input and Output Waveforms





NOTES:

- A. CONFORMS TO JEDEC REGISTRATION MO-153, VARIATION AB, REF NOTE 6
- B. DIMENSIONS ARE IN MILLIMETERS.
- C. DIMENSIONS ARE EXCLUSIVE OF BURRS, MOLD FLASH, AND TIE BAR EXTRUSIONS
- D. DIMENSIONING AND TOLERANCES PER ANSI Y14.5M, 2009.
- E. LANDPATTERN STANDARD: SOP65P640X110-14M.
- F. DRAWING FILE NAME: MKT-MTC14rev7.





NOTES:

- A. CONFORMS TO JEDEC MS-012, VARIATION AB, ISSUE C
- B. ALL DIMENSIONS ARE IN MILLIMETERS
- C. DIMENSIONS DO NOT INCLUDE MOLD FLASH OR BURRS
- D. LAND PATTERN STANDARD: SOIC127P600X145-14M
- E. CONFORMS TO ASME Y14.5M, 2009
- D. DRAWING FILENAME: MKT-M14Arev14



ON Semiconductor and  are trademarks of Semiconductor Components Industries, LLC dba ON Semiconductor or its subsidiaries in the United States and/or other countries. ON Semiconductor owns the rights to a number of patents, trademarks, copyrights, trade secrets, and other intellectual property. A listing of ON Semiconductor's product/patent coverage may be accessed at www.onsemi.com/site/pdf/Patent-Marking.pdf. ON Semiconductor reserves the right to make changes without further notice to any products herein. ON Semiconductor makes no warranty, representation or guarantee regarding the suitability of its products for any particular purpose, nor does ON Semiconductor assume any liability arising out of the application or use of any product or circuit, and specifically disclaims any and all liability, including without limitation special, consequential or incidental damages. Buyer is responsible for its products and applications using ON Semiconductor products, including compliance with all laws, regulations and safety requirements or standards, regardless of any support or applications information provided by ON Semiconductor. "Typical" parameters which may be provided in ON Semiconductor data sheets and/or specifications can and do vary in different applications and actual performance may vary over time. All operating parameters, including "Typicals" must be validated for each customer application by customer's technical experts. ON Semiconductor does not convey any license under its patent rights nor the rights of others. ON Semiconductor products are not designed, intended, or authorized for use as a critical component in life support systems or any FDA Class 3 medical devices or medical devices with a same or similar classification in a foreign jurisdiction or any devices intended for implantation in the human body. Should Buyer purchase or use ON Semiconductor products for any such unintended or unauthorized application, Buyer shall indemnify and hold ON Semiconductor and its officers, employees, subsidiaries, affiliates, and distributors harmless against all claims, costs, damages, and expenses, and reasonable attorney fees arising out of, directly or indirectly, any claim of personal injury or death associated with such unintended or unauthorized use, even if such claim alleges that ON Semiconductor was negligent regarding the design or manufacture of the part. ON Semiconductor is an Equal Opportunity/Affirmative Action Employer. This literature is subject to all applicable copyright laws and is not for resale in any manner.

PUBLICATION ORDERING INFORMATION

LITERATURE FULFILLMENT:

Literature Distribution Center for ON Semiconductor
19521 E. 32nd Pkwy, Aurora, Colorado 80011 USA
Phone: 303-675-2175 or 800-344-3860 Toll Free USA/Canada
Fax: 303-675-2176 or 800-344-3867 Toll Free USA/Canada
Email: orderlit@onsemi.com

N. American Technical Support: 800-282-9855 Toll Free
USA/Canada
Europe, Middle East and Africa Technical Support:
Phone: 421 33 790 2910
Japan Customer Focus Center
Phone: 81-3-5817-1050

ON Semiconductor Website: www.onsemi.com
Order Literature: <http://www.onsemi.com/orderlit>
For additional information, please contact your local
Sales Representative

Mouser Electronics

Authorized Distributor

Click to View Pricing, Inventory, Delivery & Lifecycle Information:

[ON Semiconductor:](#)

[MM74HCT14MTCX](#) [MM74HCT14MTC](#) [MM74HCT14M](#) [MM74HCT14N](#) [MM74HCT14MX](#) [MM74HCT14SJ](#)

Компания «Океан Электроники» предлагает заключение долгосрочных отношений при поставках импортных электронных компонентов на взаимовыгодных условиях!

Наши преимущества:

- Поставка оригинальных импортных электронных компонентов напрямую с производств Америки, Европы и Азии, а так же с крупнейших складов мира;
- Широкая линейка поставок активных и пассивных импортных электронных компонентов (более 30 млн. наименований);
- Поставка сложных, дефицитных, либо снятых с производства позиций;
- Оперативные сроки поставки под заказ (от 5 рабочих дней);
- Экспресс доставка в любую точку России;
- Помощь Конструкторского Отдела и консультации квалифицированных инженеров;
- Техническая поддержка проекта, помощь в подборе аналогов, поставка прототипов;
- Поставка электронных компонентов под контролем ВП;
- Система менеджмента качества сертифицирована по Международному стандарту ISO 9001;
- При необходимости вся продукция военного и аэрокосмического назначения проходит испытания и сертификацию в лаборатории (по согласованию с заказчиком);
- Поставка специализированных компонентов военного и аэрокосмического уровня качества (Xilinx, Altera, Analog Devices, Intersil, Interpoint, Microsemi, Actel, Aeroflex, Peregrine, VPT, Syfer, Eurofarad, Texas Instruments, MS Kennedy, Miteq, Cobham, E2V, MA-COM, Hittite, Mini-Circuits, General Dynamics и др.);

Компания «Океан Электроники» является официальным дистрибьютором и эксклюзивным представителем в России одного из крупнейших производителей разъемов военного и аэрокосмического назначения «JONHON», а так же официальным дистрибьютором и эксклюзивным представителем в России производителя высокотехнологичных и надежных решений для передачи СВЧ сигналов «FORSTAR».



JONHON

«JONHON» (основан в 1970 г.)

Разъемы специального, военного и аэрокосмического назначения:

(Применяются в военной, авиационной, аэрокосмической, морской, железнодорожной, горно- и нефтедобывающей отраслях промышленности)

«FORSTAR» (основан в 1998 г.)

ВЧ соединители, коаксиальные кабели, кабельные сборки и микроволновые компоненты:

(Применяются в телекоммуникациях гражданского и специального назначения, в средствах связи, РЛС, а так же военной, авиационной и аэрокосмической отраслях промышленности).



Телефон: 8 (812) 309-75-97 (многоканальный)

Факс: 8 (812) 320-03-32

Электронная почта: ocean@oceanchips.ru

Web: <http://oceanchips.ru/>

Адрес: 198099, г. Санкт-Петербург, ул. Калинина, д. 2, корп. 4, лит. А