



Low-Charge Injection, 8-Channel, High-Voltage Analog Switches

General Description

The MAX4800/MAX4801/MAX4802 provide high-voltage switching on eight channels for ultrasonic imaging and printer applications. The devices utilize BCDMOS process technology to provide eight high-voltage low-charge-injection SPST switches, controlled by a digital interface. Data is clocked into an internal 8-bit shift register and retained by a programmable latch with enable and clear inputs. A power-on reset function ensures that all switches are open on power-up.

The MAX4800/MAX4801/MAX4802 operate with a wide range of high-voltage supplies including: $V_{PP}/V_{NN} = +100V/-100V$, $+185V/-15V$, and $+40V/-160V$. The digital interface operates from a separate V_{DD} supply from $+2.7V$ to $+13.2V$. Digital inputs DIN , CLK , \overline{LE} , and CLR are $+13.2V$ tolerant, independent of the V_{DD} supply voltage. The MAX4802 provides integrated $35k\Omega$ bleed resistors on each switch terminal to discharge capacitive loads.

The MAX4800 and MAX4802 are drop-in replacements for the Supertex HV20220 and HV232. The devices are available in the 48-pin TQFP, 26-bump CSBGA, and 28-pin PLCC packages. The MAX4801 is a drop-in replacement for the Supertex HV20320 and is available in the 28-pin PLCC package. All devices are specified for the commercial $0^{\circ}C$ to $+70^{\circ}C$ temperature range.

Applications

Ultrasound Imaging
Printers

Features

- ◆ Pin-Compatible Replacement for Supertex HV20220 (MAX4800)
- ◆ Pin-Compatible Replacement for Supertex HV20320 (MAX4801)
- ◆ Pin-Compatible Replacement for Supertex HV232 (MAX4802)
- ◆ Flexible High-Voltage Supplies Up to $V_{PP} - V_{NN} = 200V$
- ◆ Low-Charge Injection, Low-Capacitance 22Ω Switches
- ◆ DC to 10MHz Analog-Signal Frequency Range
- ◆ $-77dB$ Off Isolation at 5MHz
- ◆ Low $10\mu A$ Quiescent Current
- ◆ Integrated Bleed Resistors (MAX4802)
- ◆ Available in PLCC, TQFP, and CSBGA Packages

MAX4800/MAX4801/MAX4802

Ordering Information/Selector Guide

PART	BLEED RESISTORS	SECOND SOURCE	PIN-PACKAGE
MAX4800CCM	No	HV20220FG	48 TQFP
MAX4800CQI	No	HV20220PJ	28 PLCC
MAX4800CXZ	No	HV220**	26 CSBGA
MAX4801CQI	No	HV20320PJ	28 PLCC
MAX4802CCM	Yes	HV232FG	48 TQFP
MAX4802CQI	Yes	HV232PJ	28 PLCC
MAX4802CXZ	Yes	HV230GA	26 CSBGA

Note: All devices are specified over the commercial $0^{\circ}C$ to $+70^{\circ}C$ temperature range.

**Not pin-for-pin compatible.



Low-Charge Injection, 8-Channel, High-Voltage Analog Switches

ABSOLUTE MAXIMUM RATINGS

(All voltages referenced to GND.)

V _{DD} Logic-Supply Voltage	-0.5V to +15V
V _{PP} - V _{NN} Supply Voltage	220V
V _{PP} Positive-Supply Voltage	-0.5V to V _{NN} + 220V
V _{NN} Negative-Supply Voltage	+0.5V to -220V
Logic Inputs \overline{LE} , CLR, CLK, DIN	-0.5V to +15V
DOUT	-0.5V to V _{DD} + 0.5V
RGND (MAX4802)	-4.5V to +0.5V
COM ₋ , NO ₋	V _{NN} to V _{PP}
Continuous Power Dissipation (T _A = +70°C)	
28-Pin PLCC (derate 10.5mW/°C above +70°C)	842mW

48-Pin TQFP (derate 22.7mW/°C above +70°C)	1818mW
26-Pin CSBGA (derate 11.8mW/°C above +70°C)	941mW
Operating Temperature Range	0°C to +70°C
Storage Temperature Range	-65°C to +150°C
Junction Temperature Range	+150°C
Lead Temperature (Soldering, 10s)	+300°C
Bump Temperature (Soldering) Lead-Free	+260°C
Bump Temperature (Soldering) Lead	+245°C

Stresses beyond those listed under "Absolute Maximum Ratings" may cause permanent damage to the device. These are stress ratings only, and functional operation of the device at these or any other conditions beyond those indicated in the operational sections of the specifications is not implied. Exposure to absolute maximum rating conditions for extended periods may affect device reliability.

ELECTRICAL CHARACTERISTICS

(V_{DD} = +2.7V to +13.2V, V_{PP} = +40V to V_{NN} + 200V, V_{NN} = -15V to -160V, T_A = T_{MIN} to T_{MAX}, unless otherwise noted. Typical values are at T_A = +25°C.) (Note 1)

PARAMETER	SYMBOL	CONDITIONS		MIN	TYP	MAX	UNITS
ANALOG SWITCH							
Analog Signal Range	V _{COM-} , V _{NO-}	(Note 2)		V _{NN} + 10		V _{PP} - 10	V
Small-Signal Switch On-Resistance	R _{ONS}	V _{PP} = +40V, V _{NN} = -160V, V _{COM-} = 0	I _{COM} = 5mA	T _A = 0°C		30	Ω
				T _A = +25°C	26	38	
				T _A = +70°C		48	
			I _{COM} = 200mA	T _A = 0°C		25	
				T _A = +25°C	22	27	
				T _A = +70°C		32	
		V _{PP} = +100V, V _{NN} = -100V, V _{COM-} = 0	I _{COM} = 5mA	T _A = 0°C		25	
				T _A = +25°C	22	27	
				T _A = +70°C		30	
			I _{COM} = 200mA	T _A = 0°C		18	
				T _A = +25°C	18	24	
				T _A = +70°C		27	
V _{PP} = +160V, V _{NN} = -40V or V _{PP} = +185V, V _{NN} = -15V, V _{COM-} = 0	I _{COM} = 5mA	T _A = 0°C		23			
		T _A = +25°C	20	25			
		T _A = +70°C		30			
	I _{COM} = 200mA	T _A = 0°C		22			
		T _A = +25°C	16	25			
		T _A = +70°C		27			
Small-Signal Switch On-Resistance Matching	ΔR _{ONS}	V _{PP} = +100V, V _{NN} = -100V, V _{COM-} = 0, I _{COM} = 5mA			5	20	%
Large-Signal Switch On-Resistance	R _{ONL}	V _{COM-} = V _{PP} - 10V, I _{COM} = 1A			15		Ω
Shunt Resistance	R _{INT}	NO ₋ or COM ₋ to RGND (MAX4802), switch off		30	35	50	kΩ

Low-Charge Injection, 8-Channel, High-Voltage Analog Switches

MAX4800/MAX4801/MAX4802

ELECTRICAL CHARACTERISTICS (continued)

($V_{DD} = +2.7V$ to $+13.2V$, $V_{PP} = +40V$ to $V_{NN} + 200V$, $V_{NN} = -15V$ to $-160V$, $T_A = T_{MIN}$ to T_{MAX} , unless otherwise noted. Typical values are at $T_A = +25^\circ C$.) (Note 1)

PARAMETER	SYMBOL	CONDITIONS	MIN	TYP	MAX	UNITS
Switch-Off Leakage	$I_{COM_ (OFF)}$, $I_{NO_ (OFF)}$	$V_{COM_}$, $V_{NO_} = V_{PP} - 10V$ or unconnected; RGND unconnected (MAX4802)	$T_A = +25^\circ C$	1	4	μA
			$T_A = T_{MIN}$ to T_{MAX}		10	
Switch-Off DC Offset		$R_L = 100k\Omega$ (MAX4800/MAX4801), No load (MAX4802)		100	300	mV
Switch-On DC Offset		$R_L = 100k\Omega$ (MAX4800/MAX4801), No load (MAX4802)		100	500	mV
Switch-Output Peak Current (Note 3)		$I_{COM_}$ duty cycle $\leq 0.1\%$	$T_A = 0^\circ C$	3		A
			$T_A = +25^\circ C$	2	3	
			$T_A = +70^\circ C$	2		
Switch-Output Isolation Diode Current (Note 3)		300ns pulse width, 2% duty cycle	$V_{PP} - V_{NN} \leq 200V$ $COM_$, NO1-NO7	300		mA
			$V_{PP} - V_{NN} \leq 200V$, NO0	30		
			$V_{PP} - V_{NN} \leq 160V$ $COM_$, NO_	750		
SWITCH DYNAMIC CHARACTERISTICS						
Off-Isolation (Note 3)	V_{ISO}	$f = 5MHz$, $R_L = 1k\Omega$, $C_L = 15pF$	-30	-33		dB
			$f = 5MHz$, $R_L = 50\Omega$	-58	-77	
Crosstalk (Note 3)	V_{CT}	$f = 5MHz$, $R_L = 50\Omega$	-60	-80		dB
$COM_$, NO_ Off-Capacitance (Note 3)	$C_{COM_ (OFF)}$, $C_{NO_ (OFF)}$	$V_{COM_} = 0$, $V_{NO_} = 0$, $f = 1MHz$	4	11	18	pF
$COM_$ On-Capacitance (Note 3)	$C_{COM_ (ON)}$	$V_{COM_} = 0$, $f = 1MHz$	20	36	56	pF
Output-Voltage Spike (Note 3)	V_{SPK}	$R_L = 50\Omega$	-150		+150	mV
Charge Injection	Q	$V_{PP} = +40V$, $V_{NN} = -160V$, $V_{COM_} = 0$		820		pC
		$V_{PP} = +100V$, $V_{NN} = -100V$, $V_{COM_} = 0$		600		
		$V_{PP} = +160V$, $V_{NN} = -40V$, $V_{COM_} = 0$		350		
LOGIC LEVELS						
Logic-Input Low Voltage	V_{IL}	$V_{DD} \geq +4.5V$			1.5	V
		$V_{DD} < +4.5V$			0.75	
Logic-Input High Voltage	V_{IH}	$V_{DD} \geq +4.5V$	$V_{DD} - 1.5$			V
		$V_{DD} < +4.5V$	$V_{DD} - 0.75$			
Logic-Input Capacitance (Note 3)	C_{IN}				10	pF
Logic-Input Leakage	I_{IN}		-1		+1	μA
DOOUT Low Voltage	V_{OL}	$V_{DD} \geq +4.5V$, $I_{SINK} = 1mA$			0.4	V
		$V_{DD} < +4.5V$, $I_{SINK} = 0.5mA$			0.4	V

Low-Charge Injection, 8-Channel, High-Voltage Analog Switches

ELECTRICAL CHARACTERISTICS (continued)

($V_{DD} = +2.7V$ to $+13.2V$, $V_{PP} = +40V$ to $V_{NN} + 200V$, $V_{NN} = -15V$ to $-160V$, $T_A = T_{MIN}$ to T_{MAX} , unless otherwise noted. Typical values are at $T_A = +25^\circ C$.) (Note 1)

PARAMETER	SYMBOL	CONDITIONS		MIN	TYP	MAX	UNITS
DOOUT High Voltage	V_{OH}	$V_{DD} \geq +4.5V$, $I_{SOURCE} = 0.5mA$		$V_{DD} - 0.5$			V
		$V_{DD} < +4.5V$, $I_{SOURCE} = 0.25mA$		$V_{DD} - 0.5$			V
POWER SUPPLIES							
V_{DD} Supply Voltage				2.7		13.2	V
V_{PP} Supply Voltage				40		$V_{NN} + 200$	V
V_{NN} Supply Voltage				-160		-15	V
V_{DD} Supply Quiescent Current	I_{DDQ}	$V_{IL} = 0$, $V_{IH} = V_{DD}$, $f_{CLK} = 0$				15	μA
V_{DD} Supply Dynamic Current	I_{DD}	$V_{DD} = +5V$, $V_{IL} = 0$, $V_{IH} = +5V$, $f_{CLK} = 5MHz$				4	mA
V_{PP} Supply Quiescent Current	I_{PPQ}	All switches remain on or off, $I_{COM_}(ON) = 5mA$			10	50	μA
V_{PP} Supply Dynamic Current	I_{PP}	50kHz output switching frequency with no load	$V_{PP} = +40V$, $V_{NN} = -160V$	$T_A = 0^\circ C$		6.5	mA
				$T_A = +25^\circ C$		6.5	
				$T_A = +70^\circ C$		6.5	
			$V_{PP} = +100V$, $V_{NN} = -100V$	$T_A = 0^\circ C$		4.0	
				$T_A = +25^\circ C$		4.0	
				$T_A = +70^\circ C$		4.0	
			$V_{PP} = +160V$, $V_{NN} = -40V$	$T_A = 0^\circ C$		4.0	
				$T_A = +25^\circ C$		4.0	
				$T_A = +70^\circ C$		4.0	
V_{NN} Supply Quiescent Current	I_{NNQ}	All switches remain on or off, $I_{COM_}(ON) = 5mA$			10	50	μA
V_{NN} Supply Dynamic Current	I_{NN}	50kHz output switching frequency with no load	$V_{PP} = +40V$, $V_{NN} = -160V$	$T_A = 0^\circ C$		6.5	mA
				$T_A = +25^\circ C$		6.5	
				$T_A = +70^\circ C$		6.5	
			$V_{PP} = +100V$, $V_{NN} = -100V$	$T_A = 0^\circ C$		4.0	
				$T_A = +25^\circ C$		4.0	
				$T_A = +70^\circ C$		4.0	
			$V_{PP} = +160V$, $V_{NN} = -40V$	$T_A = 0^\circ C$		4.0	
				$T_A = +25^\circ C$		4.0	
				$T_A = +70^\circ C$		4.0	

Low-Charge Injection, 8-Channel, High-Voltage Analog Switches

MAX4800/MAX4801/MAX4802

TIMING CHARACTERISTICS

($V_{DD} = +2.7V$ to $+13.2V$, $V_{PP} = +40V$ to $V_{NN} + 200V$, $V_{NN} = -15V$ to $-160V$, $T_A = T_{MIN}$ to T_{MAX} , unless otherwise noted. Typical values are at $T_A = +25^\circ C$.) (Note 1)

PARAMETER	SYMBOL	CONDITIONS	MIN	TYP	MAX	UNITS
ANALOG SWITCH						
Turn-On Time	t_{ON}	$V_{NO_} = V_{PP} - 10V$, $R_L = 10k\Omega$, $V_{NN} = -40V$ to $-160V$			5	μs
Turn-Off Time	t_{OFF}	$V_{NO_} = V_{PP} - 10V$, $R_L = 10k\Omega$, $V_{NN} = -40V$ to $-160V$			5	μs
Output Switching Frequency	f_{SW}	Duty cycle = 50%			50	kHz
Maximum $V_{COM_}$, $V_{NO_}$ Slew Rate	dV/dt	(Note 3)	20			V/ns
LOGIC TIMING (Figure 1)						
CLK Frequency	f_{CLK}	Daisy chaining	$V_{DD} \geq +4.5V$		5	MHz
			$V_{DD} \leq +4.5V$		2.5	
		No daisy chaining	$V_{DD} \geq +4.5V$		10	
			$V_{DD} < +4.5V$		4	
DIN to CLK Setup Time	t_{DS}	$V_{DD} \geq +4.5V$	15			ns
		$V_{DD} < +4.5V$	40			
DIN to CLK Hold Time	t_{DH}	$V_{DD} \geq +4.5V$	35			ns
		$V_{DD} < +4.5V$	60			
CLK to \overline{LE} Setup Time	t_{CS}	$V_{DD} \geq +4.5V$	150			ns
		$V_{DD} < +4.5V$	300			
\overline{LE} Low-Pulse Width	t_{WL}	$V_{DD} \geq +4.5V$	150			ns
		$V_{DD} < +4.5V$	300			
CLR High-Pulse Width	t_{WC}	$V_{DD} \geq +4.5V$	150			ns
		$V_{DD} < +4.5V$	300			
CLK Rise and Fall Times	t_R, t_F	$V_{DD} \geq +4.5V$ (Note 3)			1	μs
		$V_{DD} < +4.5V$ (Note 3)			1	
CLK to DOUT Delay	t_{DO}	$V_{DD} = +5V \pm 10\%$, $C_L \leq 50pF$	$T_A = 0^\circ C$	55	150	ns
			$T_A = +25^\circ C$	60	150	
			$T_A = +70^\circ C$	70	150	
		$T_A = T_{MIN}$ to T_{MAX}	70	280		
		$V_{DD} = +3V \pm 10\%$, $C_L \leq 50pF$	$T_A = T_{MIN}$ to T_{MAX}	70	280	

Note 1: Specifications at $0^\circ C$ are guaranteed by correlation and design. Electrical parameters are tested at worst case conditions.

Note 2: The analog signal input $V_{COM_}$ and $V_{NO_}$ must satisfy $V_{NN} \leq (V_{COM_}, V_{NO_}) \leq V_{PP}$, or remain unconnected during power-up and power-down.

Note 3: Guaranteed by characterization; not production tested.

Low-Charge Injection, 8-Channel, High-Voltage Analog Switches

Typical Operating Characteristics

($V_{DD} = +5V$, $V_{PP} = +100V$, $V_{NN} = -100V$, $T_A = +25^\circ C$, unless otherwise noted.)

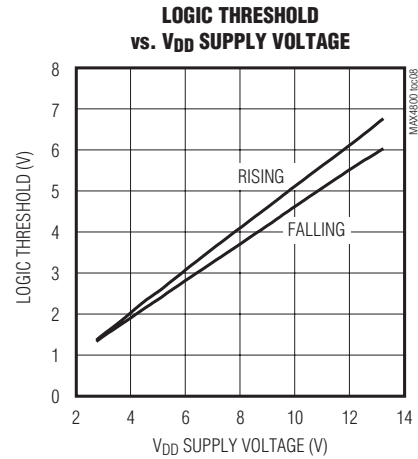
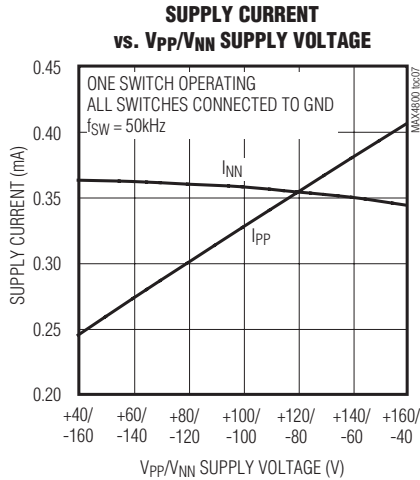
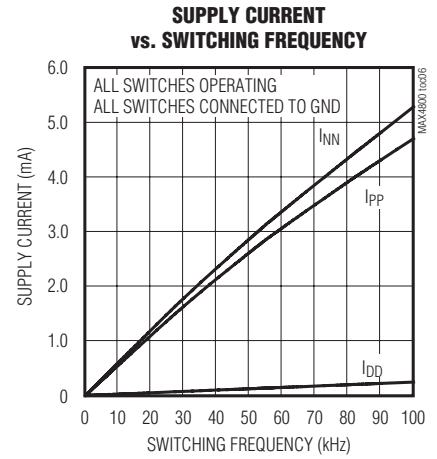
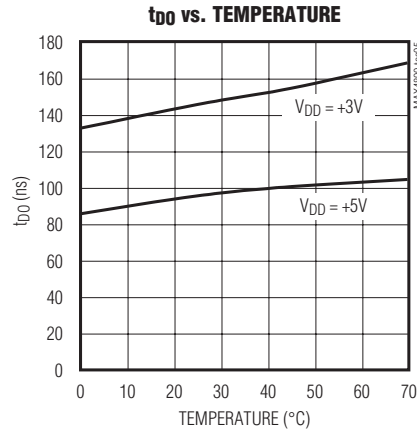
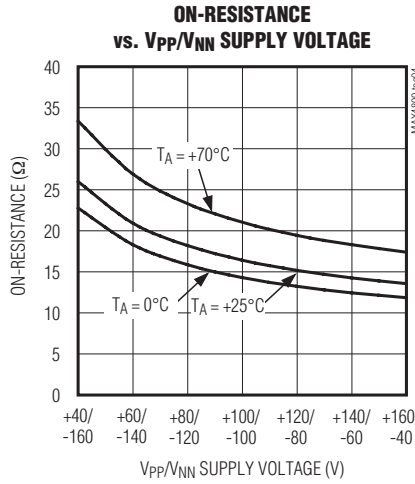
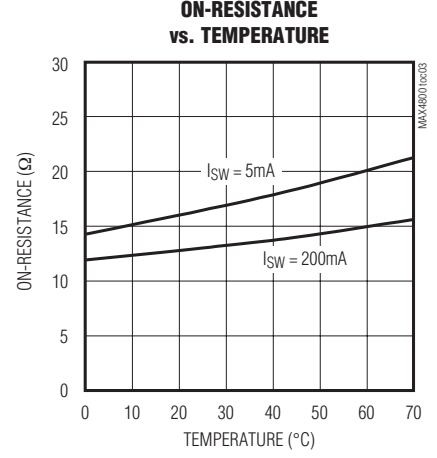
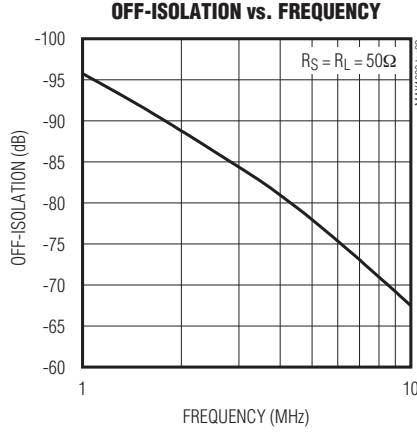
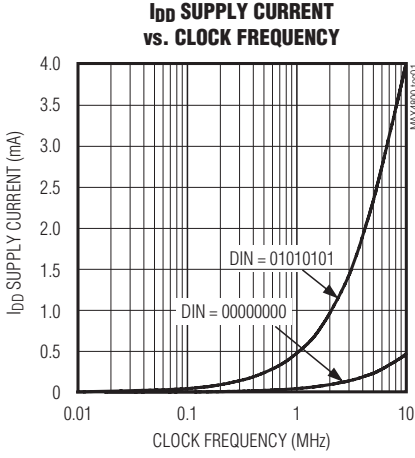

Low-Charge Injection, 8-Channel, High-Voltage Analog Switches

Pin Descriptions

PIN				NAME	FUNCTION
MAX4800 TQFP	MAX4800 CSBGA	MAX4800 PLCC	MAX4801 PLCC		
1	E4	26	26	COM5	Analog Switch 5 – Common Terminal
2, 4, 6, 7, 9, 11, 13, 15, 17, 19, 21, 23, 26, 27, 30, 31, 32, 38, 40, 42, 44, 46, 48	D6	9, 11, 15	11, 14, 15	N.C.	No Connection. Not connected internally.
3	E1	27	27	COM4	Analog Switch 4 – Common Terminal
5	E3	28	28	NO4	Analog Switch 4 – Normally Open Terminal
8	D1	1	1	COM3	Analog Switch 3 – Common Terminal
10	D3	2	2	NO3	Analog Switch 3 – Normally Open Terminal
12	D4	3	3	COM2	Analog Switch 2 – Common Terminal
14	C3	4	4	NO2	Analog Switch 2 – Normally Open Terminal
16	C4	5	5	COM1	Analog Switch 1 – Common Terminal
18	A4	6	6	NO1	Analog Switch 1 – Normally Open Terminal
20	C5	7	7	COM0	Analog Switch 0 – Common Terminal
22	D5	8	8	NO0	Analog Switch 0 – Normally Open Terminal
24	C6	10	9	V _{PP}	Positive High-Voltage Supply. Bypass V _{PP} to GND with a 0.1µF or greater ceramic capacitor.
25	C7	12	10	V _{NN}	Negative High-Voltage Supply. Bypass V _{NN} to GND with a 0.1µF or greater ceramic capacitor.
28	D7	13	12	GND	Ground
29	D9	14	13	V _{DD}	Digital-Supply Voltage. Bypass V _{DD} to GND with a 0.1µF or greater ceramic capacitor.
33	E9	16	16	DIN	Serial Data Input
34	E7	17	17	CLK	Serial Clock Input
35	E6	18	18	\overline{LE}	Latch Enable Input, Active Low
36	F7	19	19	CLR	Latch Clear Input
37	F6	20	20	DOUT	Serial Data Output
39	E5	21	21	COM7	Analog Switch 7 – Common Terminal
41	F5	22	22	NO7	Analog Switch 7 – Normally Open Terminal
43	F4	23	23	COM6	Analog Switch 6 – Common Terminal
45	H4	24	24	NO6	Analog Switch 6 – Normally Open Terminal
47	F3	25	25	NO5	Analog Switch 5 – Normally Open Terminal

MAX4800/MAX4801/MAX4802

Low-Charge Injection, 8-Channel, High-Voltage Analog Switches

Pin Descriptions (continued)

PIN			NAME	FUNCTION
MAX4802 TQFP	MAX4802 CSBGA	MAX4802 PLCC		
1	E4	26	COM5	Analog Switch 5 – Common Terminal
2, 4, 6, 7, 9, 11, 13, 15, 17, 19, 21, 23, 26, 30, 31, 32, 38, 40, 42, 44, 46, 48	—	9, 15	N.C.	Not Connected Internally
3	E1	27	COM4	Analog Switch 4 – Common Terminal
5	E3	28	NO4	Analog Switch 4 – Normally Open Terminal
8	D1	1	COM3	Analog Switch 3 – Common Terminal
10	D3	2	NO3	Analog Switch 3 – Normally Open Terminal
12	D4	3	COM2	Analog Switch 2 – Common Terminal
14	C3	4	NO2	Analog Switch 2 – Normally Open Terminal
16	C4	5	COM1	Analog Switch 1 – Common Terminal
18	A4	6	NO1	Analog Switch 1 – Normally Open Terminal
20	C5	7	COM0	Analog Switch 0 – Common Terminal
22	D5	8	NO0	Analog Switch 0 – Normally Open Terminal
24	C6	10	V _{PP}	Positive High-Voltage Supply. Bypass V _{PP} to GND with a 0.1μF or greater ceramic capacitor.
25	C7	12	V _{NN}	Negative High-Voltage Supply. Bypass V _{NN} to GND with a 0.1μF or greater ceramic capacitor.
27	D6	11	RGND	Bleed Resistor Ground
28	D7	13	GND	Ground
29	D9	14	V _{DD}	Digital-Supply Voltage. Bypass V _{DD} to GND with a 0.1μF or greater ceramic capacitor.
33	E9	16	DIN	Serial Data Input
34	E7	17	CLK	Serial Clock Input
35	E6	18	\overline{LE}	Latch Enable Input, Active Low
36	F7	19	CLR	Latch Clear Input
37	F6	20	DOUT	Serial Data Output
39	E5	21	COM7	Analog Switch 7 – Common Terminal
41	F5	22	NO7	Analog Switch 7 – Normally Open Terminal
43	F4	23	COM6	Analog Switch 6 – Common Terminal
45	H4	24	NO6	Analog Switch 6 – Normally Open Terminal
47	F3	25	NO5	Analog Switch 5 – Normally Open Terminal

Low-Charge Injection, 8-Channel, High-Voltage Analog Switches

MAX4800/MAX4801/MAX4802

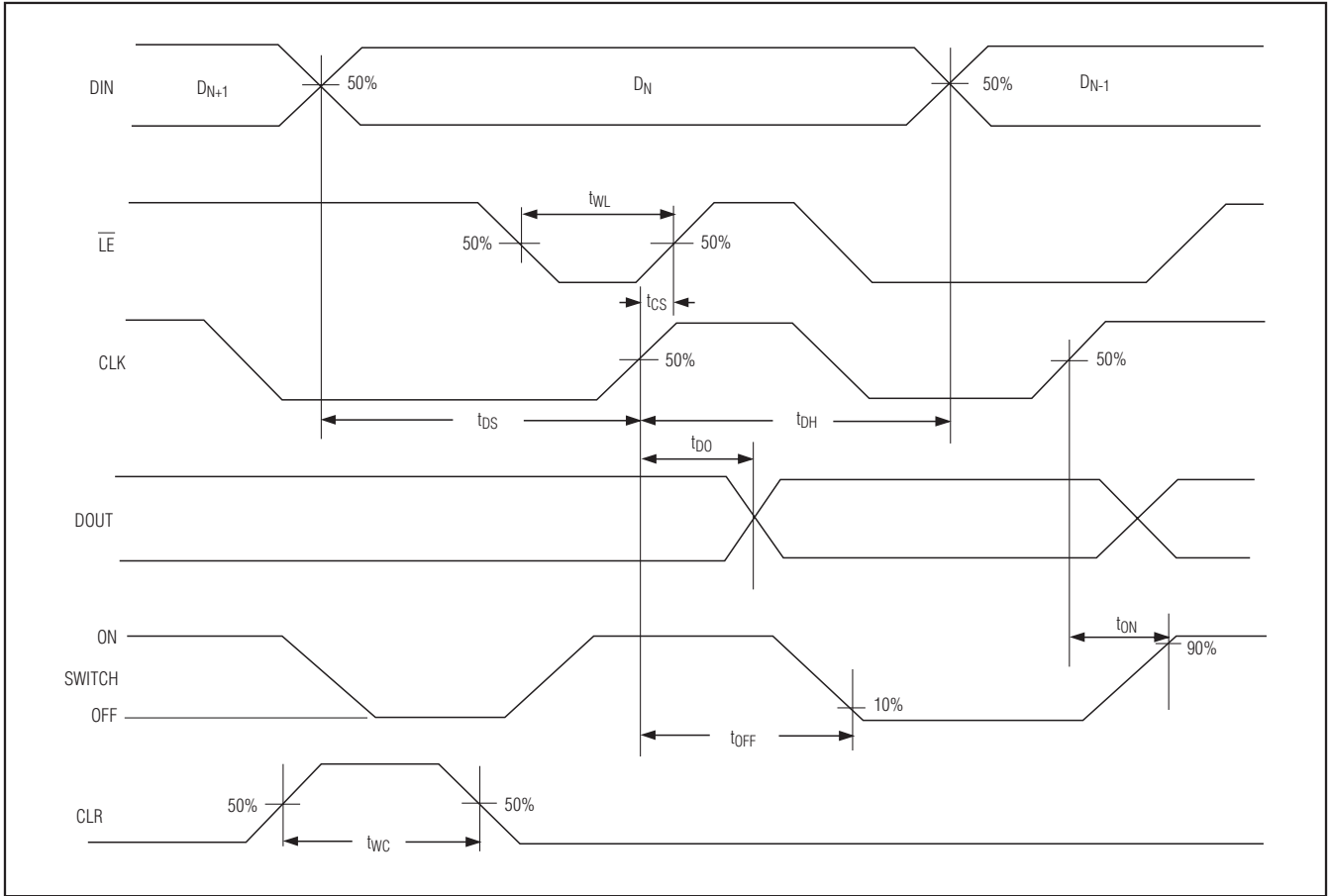

Figure 1. Serial Interface Timing

Detailed Description

The MAX4800/MAX4801/MAX4802 provide high-voltage switching on eight channels for ultrasound imaging and printer applications. The devices utilize BCDMOS process technology to provide eight high-voltage low-charge-injection SPST switches, controlled by a digital interface. Data is clocked into an internal 8-bit shift register and retained by a programmable latch with enable and clear inputs. A power-on reset function ensures that all switches are open on power-up.

The MAX4800/MAX4801/MAX4802 operate with a wide range of high-voltage supplies including: $V_{PP}/V_{NN} = +100V/-100V$, $+185V/-15V$, or $+40V/-160V$. The digital interface operates from a separate V_{DD} supply from $+2.7V$ to $+13.2V$. Digital inputs DIN, CLK, \overline{LE} , and CLR are $+13.2V$ tolerant, independent of the V_{DD} supply voltage. The MAX4802 provides integrated $35k\Omega$ bleed

resistors on each switch terminal to discharge capacitive loads.

The MAX4800 and MAX4802 are drop-in replacements for the Supertex HV20220 and HV232, respectively. The MAX4801 is a drop-in replacement for the Supertex HV20320.

Analog Switch

The MAX4800/MAX4801/MAX4802 allow a peak-to-peak analog signal range from $V_{NN} + 10V$ to $V_{PP} - 10V$. Analog switch inputs must be unconnected, or satisfy $V_{NN} \leq (V_{COM_}, V_{NO_}) \leq V_{PP}$ during power-up and power-down.

High-Voltage Supplies

The MAX4800/MAX4801/MAX4802 allow a wide range of high-voltage supplies. The devices operate with V_{NN} from $-160V$ to $-15V$ and V_{PP} from $+40V$ to $V_{NN} + 200V$.

Low-Charge Injection, 8-Channel, High-Voltage Analog Switches

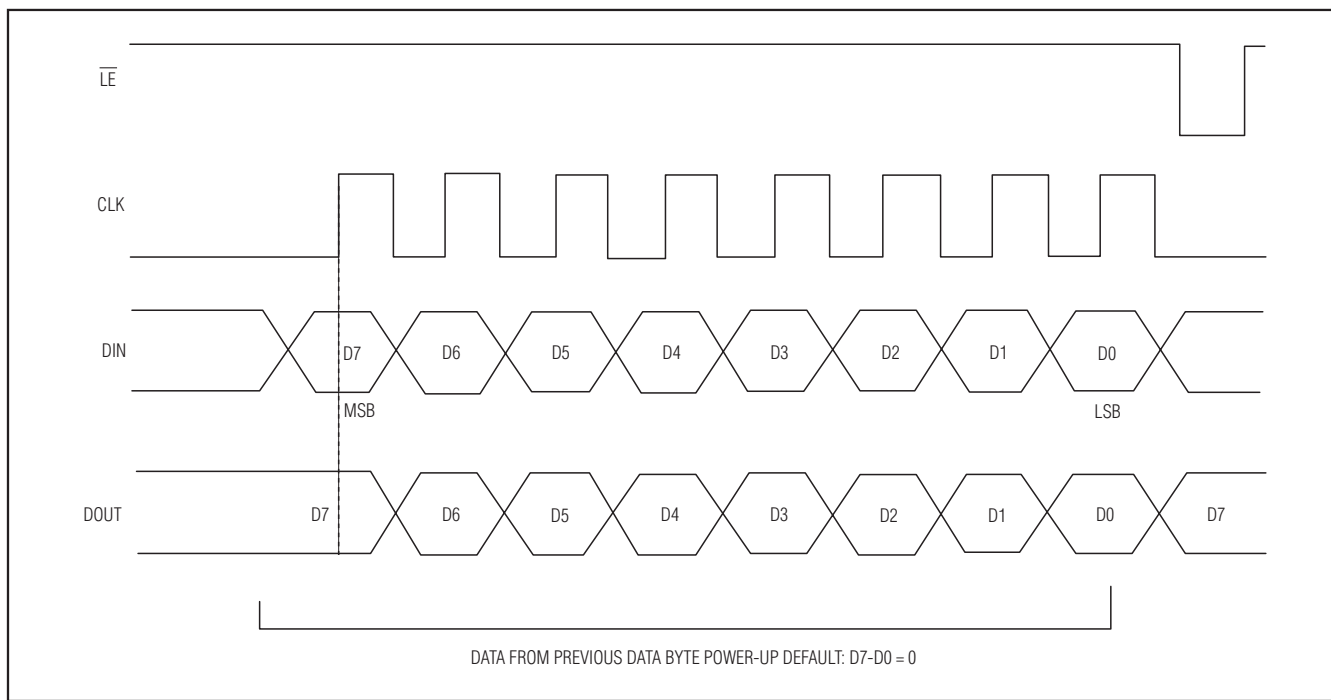

Figure 2. Latch Enable Interface Timing

When V_{NN} is connected to GND (single-supply applications), the devices operate with V_{PP} up to +200V. The V_{PP} and V_{NN} high-voltage supplies are not required to be symmetrical, but the voltage difference $V_{PP} - V_{NN}$ must not exceed 200V.

Bleed Resistors (MAX4802)

The MAX4802 features integrated 35k Ω bleed resistors to discharge capacitive loads such as piezoelectric transducers. Each analog switch terminal is connected to RGND with a bleed resistor.

Serial Interface

The MAX4800/MAX4801/MAX4802 are controlled by a serial interface with an 8-bit serial shift register and transparent latch. Each of the eight data bits controls a single analog switch (see Table 1). Data on DIN is clocked with the most significant bit (MSB) first into the shift register on the rising edge of CLK. Data is clocked out of the shift register onto DOUT on the rising edge of CLK. DOUT reflects the status of DIN, delayed by eight clock cycles (see Figures 1 and 2).

Latch Enable (\overline{LE})

Drive \overline{LE} logic-low to change the contents of the latch and update the state of the high-voltage switches (Figure 2). Drive \overline{LE} logic-high to freeze the contents of the latch and prevent changes to the switch states. To reduce noise due to clock feedthrough, drive \overline{LE} logic-high while data is clocked into the shift register. After the data shift register is loaded with valid data, pulse \overline{LE} logic-low to load the contents of the shift register into the latch.

Latch Clear (CLR)

The MAX4800/MAX4801/MAX4802 feature a latch clear input. Drive CLR logic-high to reset the contents of the latch to zero and open all switches. CLR does not affect the contents of the data shift register. Pulse \overline{LE} logic-low to reload the contents of the shift register into the latch.

Power-On Reset

The MAX4800/MAX4801/MAX4802 feature a power-on reset circuit to ensure all switches are open at power-on. The internal 8-bit serial shift register and latch are set to zero on power-up.

Low-Charge Injection, 8-Channel, High-Voltage Analog Switches

MAX4800/MAX4801/MAX4802

Table 1. Serial Interface Programming

DATA BITS								CONTROL BITS		FUNCTION							
D0 (LSB)	D1	D2	D3	D4	D5	D6	D7 (MSB)	\overline{LE}	CLR	SW0	SW1	SW2	SW3	SW4	SW5	SW6	SW7
L								L	L	OFF							
H								L	L	ON							
	L							L	L		OFF						
	H							L	L		ON						
		L						L	L			OFF					
		H						L	L			ON					
			L					L	L				OFF				
			H					L	L				ON				
				L				L	L					OFF			
				H				L	L					ON			
					L			L	L						OFF		
					H			L	L						ON		
						L		L	L							OFF	
						H		L	L							ON	
							L	L	L								OFF
							H	L	L								ON
X	X	X	X	X	X	X	X	H	L	HOLD PREVIOUS STATE							
X	X	X	X	X	X	X	X	X	H	OFF	OFF	OFF	OFF	OFF	OFF	OFF	OFF

X = Don't Care

Applications Information

Logic Levels

The MAX4800/MAX4801/MAX4802 digital interface inputs CLK, DIN, \overline{LE} , and CLR are tolerant of up to +13.2V, independent of the VDD supply voltage, allowing compatibility with higher voltage controllers.

Daisy Chaining Multiple Devices

Digital output DOUT is provided to allow the connection of multiple MAX4800/MAX4801/MAX4802 devices by daisy chaining (Figure 3). Connect each DOUT to the DIN of the subsequent device in the chain. Connect CLK, \overline{LE} , and CLR inputs of all devices, and drive \overline{LE} logic-low to update all devices simultaneously. Drive CLR high to open all the switches simultaneously. Additional shift registers may be included anywhere in series with the MAX4800/MAX4801/MAX4802 data chain.

Supply Sequencing and Bypassing

The MAX4800/MAX4801/MAX4802 do not require special sequencing of the VDD, VPP, and VNN supply voltages; however, analog switch inputs must be unconnected, or satisfy $V_{NN} \leq (V_{COM_}, V_{NO_}) \leq V_{PP}$ during power-up and power-down. Bypass VDD, VNN, and VPP to GND with a 0.1µF ceramic capacitor as close to the device as possible.

Chip Information

PROCESS: BCDMOS

Low-Charge Injection, 8-Channel, High-Voltage Analog Switches

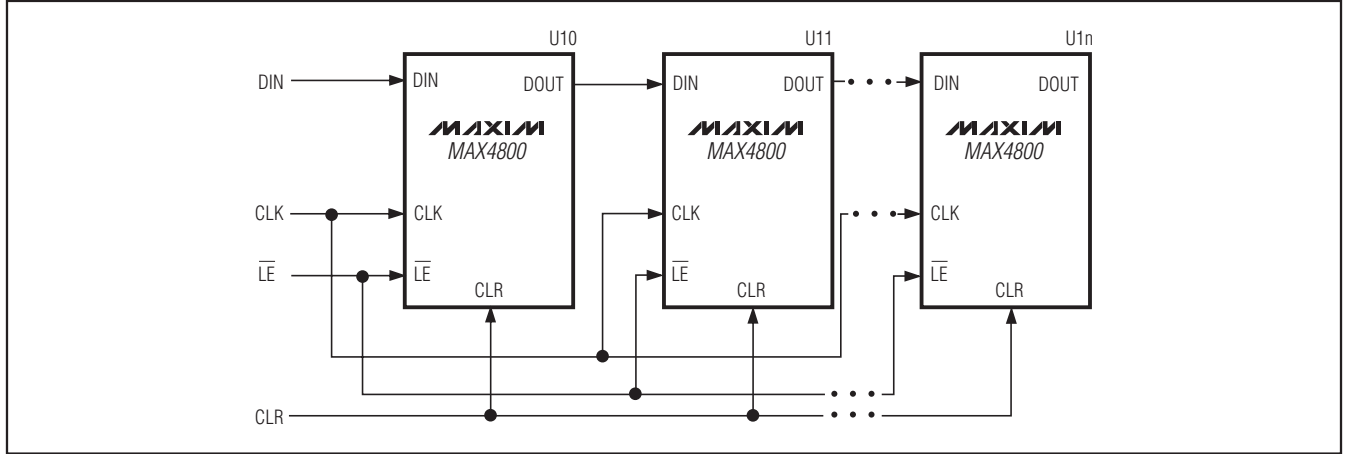
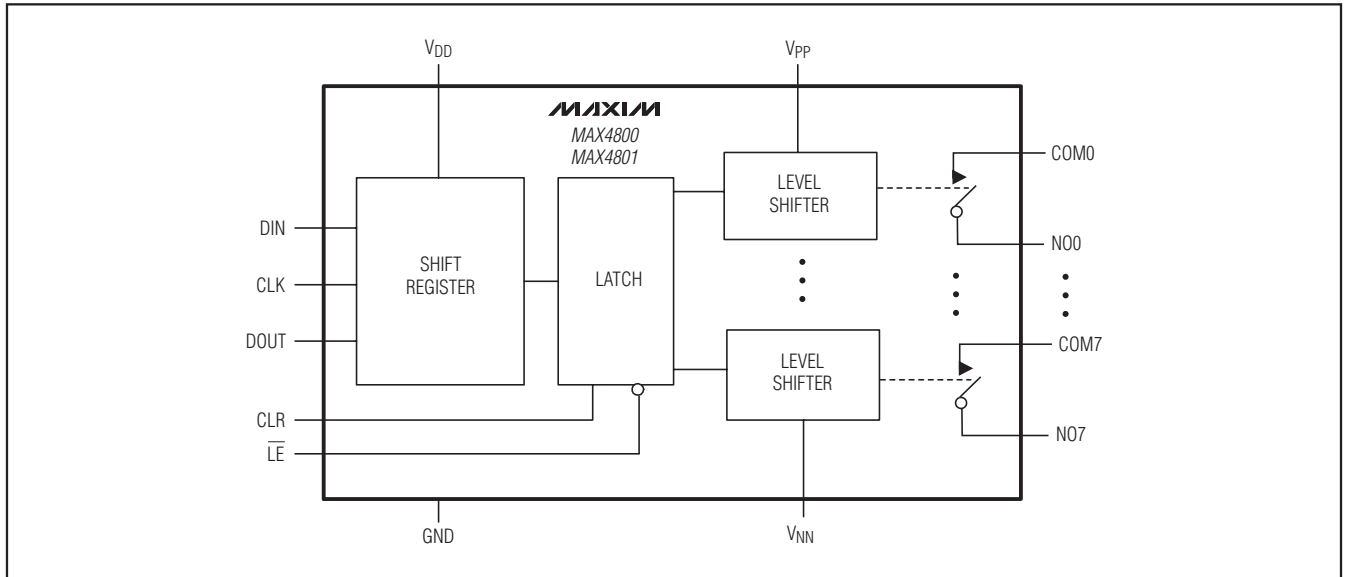

Figure 3. Interfacing Multiple Devices by Daisy-Chaining

Functional Diagrams



Low-Charge Injection, 8-Channel, High-Voltage Analog Switches

Functional Diagrams (continued)

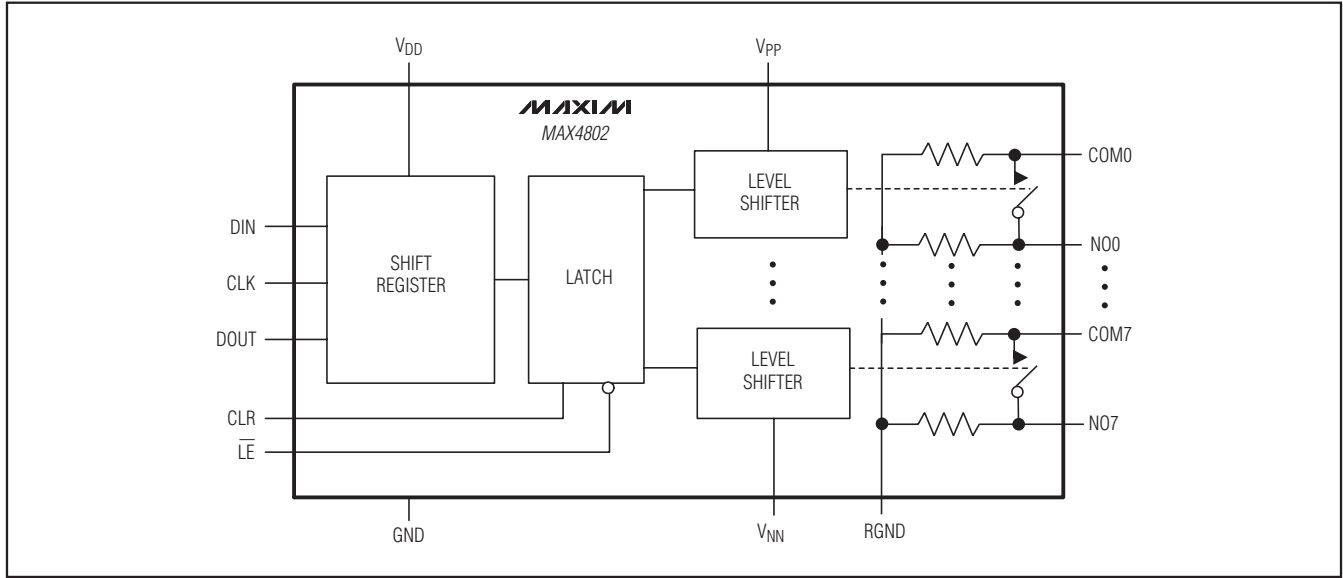

MAX4800/MAX4801/MAX4802

Low-Charge Injection, 8-Channel, High-Voltage Analog Switches

Pin Configurations

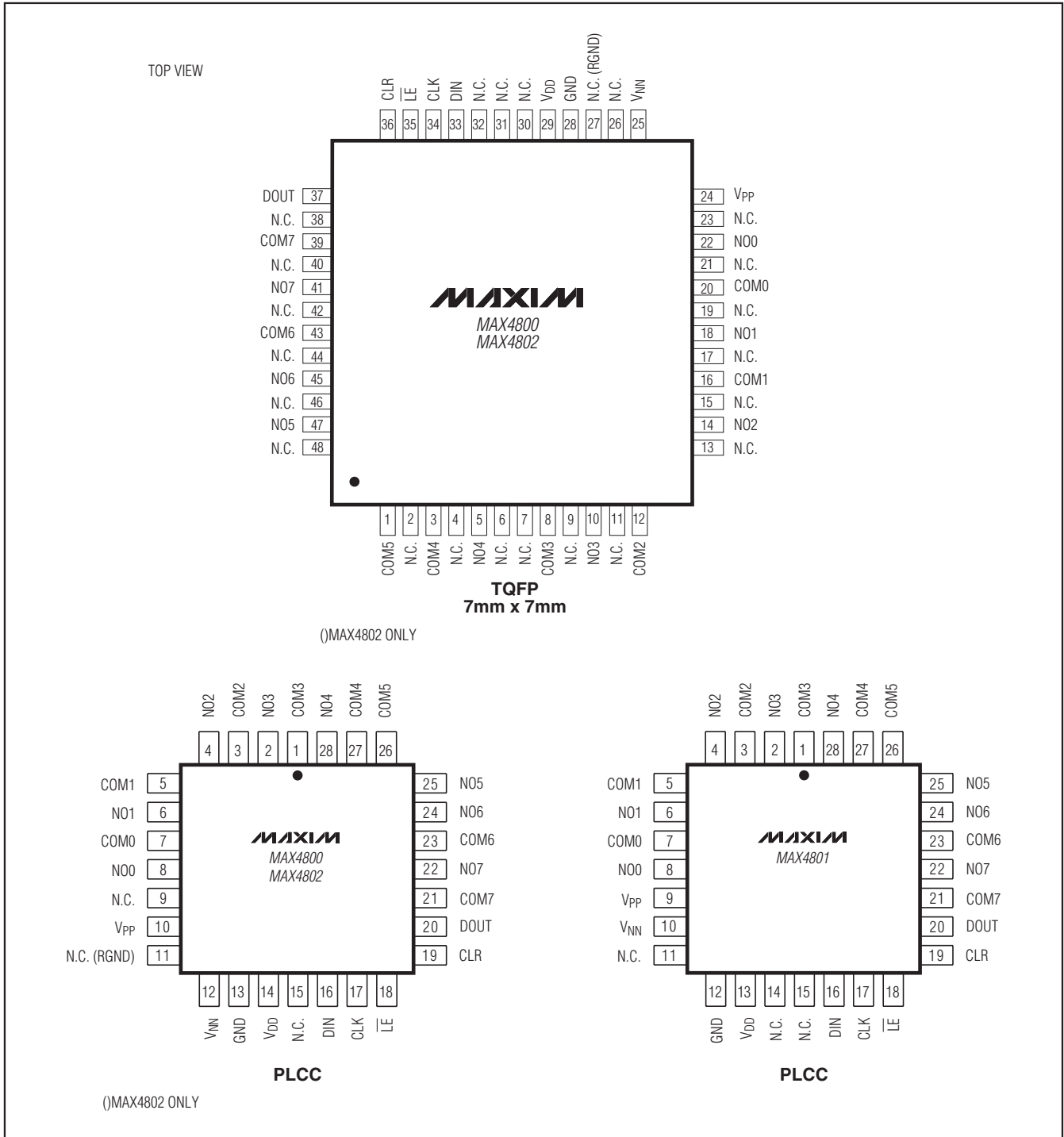

Low-Charge Injection, 8-Channel, High-Voltage Analog Switches

Pin Configurations (continued)

MAX4800/MAX4801/MAX4802

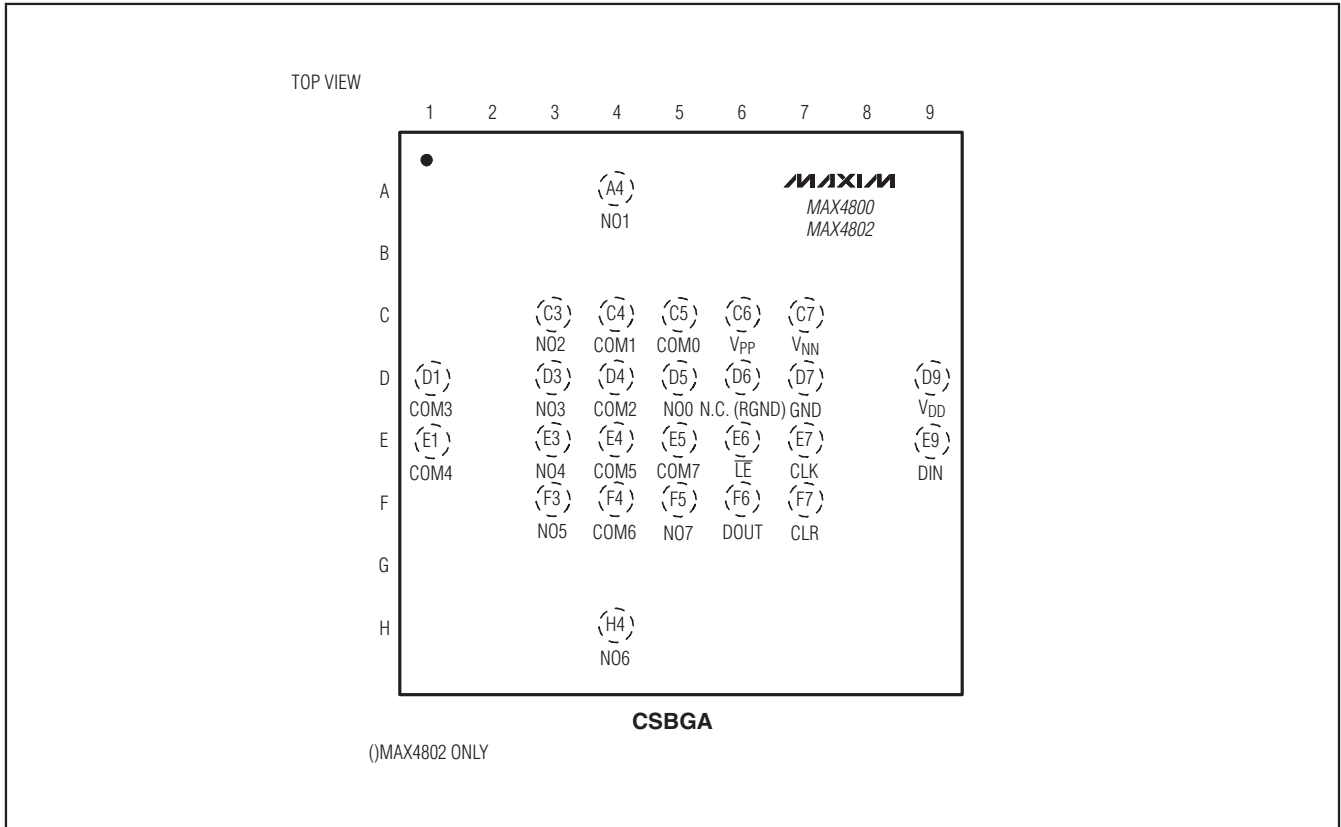

Package Information

For the latest package outline information and land patterns, go to www.maxim-ic.com/packages. Note that a "+", "#", or "-" in the package code indicates RoHS status only. Package drawings may show a different suffix character, but the drawing pertains to the package regardless of RoHS status.

PACKAGE TYPE	PACKAGE CODE	DOCUMENT NO.
28 PLCC	Q28-4	21-0049
26 CSBGA	X07265-1	21-0158
48 TQFP	C48-6	21-0054

Low-Charge Injection, 8-Channel, High-Voltage Analog Switches

Revision History

REVISION NUMBER	REVISION DATE	DESCRIPTION	PAGES CHANGED
0	8/06	Initial release.	—
1	3/07	<ul style="list-style-type: none"> Updated "Second Source" column and revised two package codes in the <i>Ordering Information/Selector Guide</i> section. Updated the pin numbers of the MAX4802 TQFN in the <i>Pin Descriptions</i> column. Replaced the TQFN <i>Pin Configurations</i>. Added package drawing 21-0158 to the <i>Package Information</i> section. 	1, 7, 8, 14, 18, 19, 20, 21
2	5/09	Deleted TQFN from the <i>Ordering Information/Selector Guide</i> , <i>Pin Descriptions</i> , <i>Pin Configurations</i> , and <i>Package Information</i> sections.	1, 7, 8, 14, 20, 21

Maxim cannot assume responsibility for use of any circuitry other than circuitry entirely embodied in a Maxim product. No circuit patent licenses are implied. Maxim reserves the right to change the circuitry and specifications without notice at any time.

16 **Maxim Integrated Products, 120 San Gabriel Drive, Sunnyvale, CA 94086 408-737-7600**

Компания «Океан Электроники» предлагает заключение долгосрочных отношений при поставках импортных электронных компонентов на взаимовыгодных условиях!

Наши преимущества:

- Поставка оригинальных импортных электронных компонентов напрямую с производств Америки, Европы и Азии, а так же с крупнейших складов мира;
- Широкая линейка поставок активных и пассивных импортных электронных компонентов (более 30 млн. наименований);
- Поставка сложных, дефицитных, либо снятых с производства позиций;
- Оперативные сроки поставки под заказ (от 5 рабочих дней);
- Экспресс доставка в любую точку России;
- Помощь Конструкторского Отдела и консультации квалифицированных инженеров;
- Техническая поддержка проекта, помощь в подборе аналогов, поставка прототипов;
- Поставка электронных компонентов под контролем ВП;
- Система менеджмента качества сертифицирована по Международному стандарту ISO 9001;
- При необходимости вся продукция военного и аэрокосмического назначения проходит испытания и сертификацию в лаборатории (по согласованию с заказчиком);
- Поставка специализированных компонентов военного и аэрокосмического уровня качества (Xilinx, Altera, Analog Devices, Intersil, Interpoint, Microsemi, Actel, Aeroflex, Peregrine, VPT, Syfer, Eurofarad, Texas Instruments, MS Kennedy, Miteq, Cobham, E2V, MA-COM, Hittite, Mini-Circuits, General Dynamics и др.);

Компания «Океан Электроники» является официальным дистрибьютором и эксклюзивным представителем в России одного из крупнейших производителей разъемов военного и аэрокосмического назначения «JONHON», а так же официальным дистрибьютором и эксклюзивным представителем в России производителя высокотехнологичных и надежных решений для передачи СВЧ сигналов «FORSTAR».



JONHON

«JONHON» (основан в 1970 г.)

Разъемы специального, военного и аэрокосмического назначения:

(Применяются в военной, авиационной, аэрокосмической, морской, железнодорожной, горно- и нефтедобывающей отраслях промышленности)

«FORSTAR» (основан в 1998 г.)

ВЧ соединители, коаксиальные кабели, кабельные сборки и микроволновые компоненты:

(Применяются в телекоммуникациях гражданского и специального назначения, в средствах связи, РЛС, а так же военной, авиационной и аэрокосмической отраслях промышленности).



Телефон: 8 (812) 309-75-97 (многоканальный)

Факс: 8 (812) 320-03-32

Электронная почта: ocean@oceanchips.ru

Web: <http://oceanchips.ru/>

Адрес: 198099, г. Санкт-Петербург, ул. Калинина, д. 2, корп. 4, лит. А