



ON Semiconductor®

<http://onsemi.com>

LC88F58B0A

CMOS IC

FROM 128K byte, RAM 6K byte on-chip

16-bit 1-chip Microcontroller

Overview

The LC88F58B0A is a 16-bit microcomputer that, centered around an Xstromy16 CPU, integrates on a single chip a number of hardware features such as 128K-byte flash ROM (onboard programmable), 6K-byte RAM, six 16-bit timers, a base timer serving as a time-of-day clock, two synchronous SIO interfaces with automatic transmission capability, a single master I²C/synchronous SIO interface, two asynchronous SIO (UART) interfaces, a 11-channel 12-bit resolution AD converter, a motor drive signal generator circuit, two multifrequency 12-bit PWM modules, a watchdog timer, a system clock frequency divider, a 40-source (24 modules) 16-vector interrupt feature, and on-chip debugger feature.

Features

■Xstromy16 CPU

- 4G-byte address space
- General-purpose registers: 16 bits × 16 registers

■Flash ROM

- Capable of onboard programming with a wide range of voltage levels (3.0 to 5.5V).
- Block-erasable in 128 or 1K byte units.
- Data written in 2-byte units.
- 131072 × 8 bits

■RAM

- 6144 × 8 bits

* This product is licensed from Silicon Storage Technology, Inc. (USA).

■ Minimum Instruction Cycle Time (tCYC)

- 83.3 ns (12MHz) $V_{DD} = 4.5$ to $5.5V$
- 100 ns (10MHz) $V_{DD} = 3.0$ to $5.5V$
- 500 ns (2MHz) $V_{DD} = 2.2$ to $5.5V$

■ Ports

- Normal withstand voltage I/O ports
Ports whose I/O direction can be designated in 1 bit units : 52 (P0n, P1n, P2n, P30 to P33, P4n, P6n, P70 to P72, PA0 to PA3, PC2)
- Oscillation/normal withstand voltage I/O ports : 2 (PC0, PC1)
- Oscillation dedicated ports : 2 (CF1, CF2)
- Reset pins : 1 (RESB)
- TEST pins : 1 (TEST)
- Power pins : 6 (V_{SS1} to 3, V_{DD1} to 3)

■ Timers

- Timer 0: 16-bit timer that supports PWM/toggle outputs
 - 1) 5-bit prescaler
 - 2) 8-bit PWM $\times 2$, 8-bit timer + 8-bit PWM mode selectable
 - 3) Clock source selectable from system clock, OSC0, OSC1, and internal RC oscillator
- Timer 1: 16-bit timer with capture registers
 - 1) 5-bit prescaler
 - 2) May be divided into 2 channels of 8-bit timer
 - 3) Clock source selectable from system clock, OSC0, OSC1, and internal RC oscillator
- Timer 2: 16-bit timer with capture registers
 - 1) 4-bit prescaler
 - 2) May be divided into 2 channels of 8-bit timer
 - 3) Clock source selectable from system clock, OSC0, OSC1, and external events
- Timer 3: 16-bit timer that supports PWM/toggle outputs
 - 1) 8-bit prescaler
 - 2) 8-bit timer $\times 2$ ch or 8-bit timer + 8-bit PWM mode selectable
 - 3) Clock source selectable from system clock, OSC0, OSC1, and external events
- Timer 4: 16-bit timer that supports toggle outputs
 - 1) Clock source selectable from system clock and prescaler 0
- Timer 5: 16-bit timer that supports toggle outputs
 - 1) Clock source selectable from system clock and prescaler 0
- Base timer
 - 1) Clock may be selected from OSC0 (32.768kHz crystal oscillator) and frequency-divided output of system clock.
 - 2) Interrupts can be generated in 7 timing schemes.

■ Serial Interfaces

- SIO0: 8-bit synchronous SIO
 - 1) LSB first/MSB first mode selectable
 - 2) Supports data communication with a data length of 8 bits or less (1 to 8 bits specifiable)
 - 3) Built-in 8-bit baudrate generator (4 tCYC to 512 tCYC transfer clocks)
 - 4) Continuous/automatic data transmission (9- to 32768-bit units specifiable)
 - 5) Interval function (intervals specifiable in 0 to 64 tSCK units)
 - 6) Wakeup function
- SIO1: 8-bit synchronous SIO
 - 1) LSB first/MSB first mode selectable
 - 2) Supports data communication with a data length of 8 bits or less (1 to 8 bits specifiable)
 - 3) Built-in 8-bit baudrate generator (4 tCYC to 512 tCYC transfer clocks)
 - 4) Continuous/automatic data transmission (9- to 32768-bit units specifiable)
 - 5) Interval function (intervals specifiable in 0 to 64 tSCK units)
 - 6) Wakeup function
- SMIIC0: Single master I²C/8-bit synchronous SIO
 - Mode 0: Single-master mode communication
 - Mode 1: Synchronous 8-bit serial I/O (MSB first)
- UART0
 - 1) Data length : 8 bits (LSB first)
 - 2) Start bits : 1 bit
 - 3) Stop bits : 1 bit
 - 4) Parity bits : None/even parity/odd parity
 - 5) Transfer rate : 4/8 cycle
 - 6) Baudrate source clock: P07 input signal used as a 1 cycle signal (TOPPWMH can be used as a clock source)
 - 7) Full duplex communication

Note: The “cycle” refers to one period of the baudrate clock source.
- UART2
 - 1) Data length : 8 bits (LSB first)
 - 2) Start bits : 1 bit
 - 3) Stop bits : 1/2 bit
 - 4) Parity bits : None/even parity/odd parity
 - 5) Transfer rate : 8 to 4096 cycle
 - 6) Baudrate source clock : System clock/OSC0/OSC1
 - 7) Wakeup function
 - 8) Full duplex communication

Note: The “cycle” refers to one period of the baudrate clock source.

■ AD Converter

- 1) 12/8 bits resolution selectable
- 2) Analog input: 11 channels
- 3) Comparator mode
- 4) Automatic reference voltage generation

■ PWM

- PWM0: Multifrequency 12-bit PWM × 2 channels (PWM0A and PWM0B)
 - 1) 2-channel pairs controlled independently of one another
 - 2) Clock source selectable from system clock or OSC1
 - 3) 8-bit prescaler: $TPWMR0 = (\text{prescaler value} + 1) \times \text{clock period}$
 - 4) 8-bit fundamental wave PWM generator circuit + 4-bit additional pulse generator circuit
 - 5) Fundamental wave PWM mode
 - Fundamental wave period : 16 TPWMR0 to 256 TPWMR0
 - High pulse width : 0 to (Fundamental wave period - TPWMR0)
 - 6) Fundamental wave + additional pulse mode
 - Fundamental wave period : 16 TPWMR0 to 256 TPWMR0
 - Overall period : Fundamental wave period × 16
 - High pulse width : 0 to (Fundamental wave period - TPWMR0)

■ Watchdog Timer

- 1) Driven by the base timer + internal watchdog timer dedicated counter
- 2) Interrupt or reset mode selectable

■ Motor Drive Signal Generator Circuit

■ Interrupts (peripheral function)

- 40 sources (24 modules), 16 vector addresses
 - 1) Provides three levels (low (L), high (H), and highest (X)) of multiplex interrupt control. Any interrupt requests of the level equal to or lower than the current interrupt are not accepted.
 - 2) When interrupt requests to two or more vector addresses occur at the same time, the interrupt of the highest level takes precedence over the other interrupts. For interrupts of the same level, the interrupt into the smallest vector address takes precedence.

No.	Vector Address	Interrupt Module
1	08000H	Watchdog timer (1)
2	08004H	Base timer (2)
3	08008H	Timer 0 (2)
4	0800CH	INT0 (1)
5	08010H	
6	08014H	INT1 (1)
7	08018H	INT2 (1)/timer 1 (2)/UART2 (4)
8	0801CH	INT3 (1)/timer 2 (4)/SMIIC0 (1)
9	08020H	INT4 (1)/timer 3 (2)
10	08024H	INT5 (1)/timer 4 (1)/SIO1 (2)
11	08028H	USM0 (3)
12	0802CH	PWM0 (1)
13	08030H	ADC (1)/timer 5 (1)
14	08034H	INT6 (1)
15	08038H	INT7 (1)/SIO0 (2)
16	0803CH	Port 0 (3)

- 3 priority levels selectable.
- Of interrupts of the same level, the one with the smallest vector address takes precedence.
- A number enclosed in parentheses denotes the number of sources.

■ Subroutine Stack: 6K-byte RAM area

- Subroutine calls that automatically save PSW, interrupt vector calls: 6 bytes
- Subroutine calls that do not automatically save PSW: 4 bytes

■ Multiplication/Division Instructions

- 16 bits × 16 bits (18 tCYC execution time)
- 16 bits ÷ 16 bits (18 to 19 tCYC execution time)
- 32 bits ÷ 16 bits (18 to 19 tCYC execution time)

■ Oscillator Circuits

- RC oscillator circuit (internal): For system clock
- OSC1 (CF oscillator circuit): For system clock, built-in Rf circuit
- OSC0 (crystal oscillator circuit): For low-speed system clock
- SLRC oscillator circuit (internal): For system clock (exception processing time)

■ System Clock Divider Function

- Can run on low current.
- 1/1 to 1/128 of the system clock frequency can be set.

LC88F58B0A

■ Standby Function

- HALT mode: Halts instruction execution while allowing the peripheral circuits to continue operation.
 - 1) Oscillation is not stopped automatically.
 - 2) Released by a system reset or occurrence of an interrupt.
- HOLD mode: Suspends instruction execution and the operation of the peripheral circuits.
 - 1) OSC1, RC and OSC0 oscillators automatically stop.
 - 2) There are three ways of releasing the HOLD mode.
 - (1) Setting the reset pin to the low level
 - (2) Setting at least one of the INT0, INT1, INT2, INT4, INT5, INT6, and INT7 pins to the specified level
 - (3) Having an interrupt source established at port 0
 - (4) Having an interrupt established at SIO0 or SIO1
 - (5) Having an interrupt established at UART2
- HOLDX mode: Suspends instruction execution and the operation of the peripheral circuits except those which run on OSC0.
 - 1) OSC1 and RC oscillations automatically stop.
 - 2) OSC0 maintains the state that is established when the HOLDX mode is entered.
 - 3) There are four ways of releasing the HOLDX mode.
 - (1) Setting the reset pin to the low level
 - (2) Setting at least one of the INT0, INT1, INT2, INT4, INT5, INT6, and INT7 pins to the specified level
 - (3) Having an interrupt source established at port 0
 - (4) Having an interrupt source established at the base timer circuit
 - (5) Having an interrupt established at SIO0 or SIO1
 - (6) Having an interrupt established at UART2

■ On-chip Debugger Function

- Supports software debugging with the IC mounted on the target board.
- Supports source line debugging and tracing functions, and breakpoint setting.
- Single-wire communication

■ Package Form

- SQFP64 (10×10): Lead-free and halogen-free type

■ Development Tools

- On-chip debugger: EOCUIF1 + LC88F58B0A

■ Programming Board

Package	Programming Board
SQFP64 (10 × 10)	W88F58SQ

■ Flash Programming

Manufacturer	Model Name	Supported Version	Device
Flash Support Group (Single)	AF9708/09/09B/09C	Revision : After Rev.03.04	LC88F58B0A
Flash Support Group (Gang)	AF9723/23B	Revision : After Rev.02.29	LC88F58B0A
	AF9833	Revision : After Rev.01.90	
Our company	SKK/SKK Type-B	Revision : After Rev.01.13	LC88F58B0A

LC88F58B0A

Package Dimensions

unit : mm (typ)
3190A

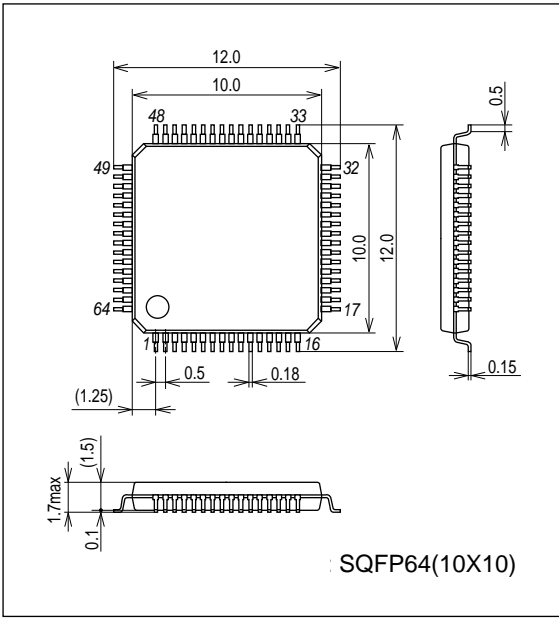

Pin Assignment

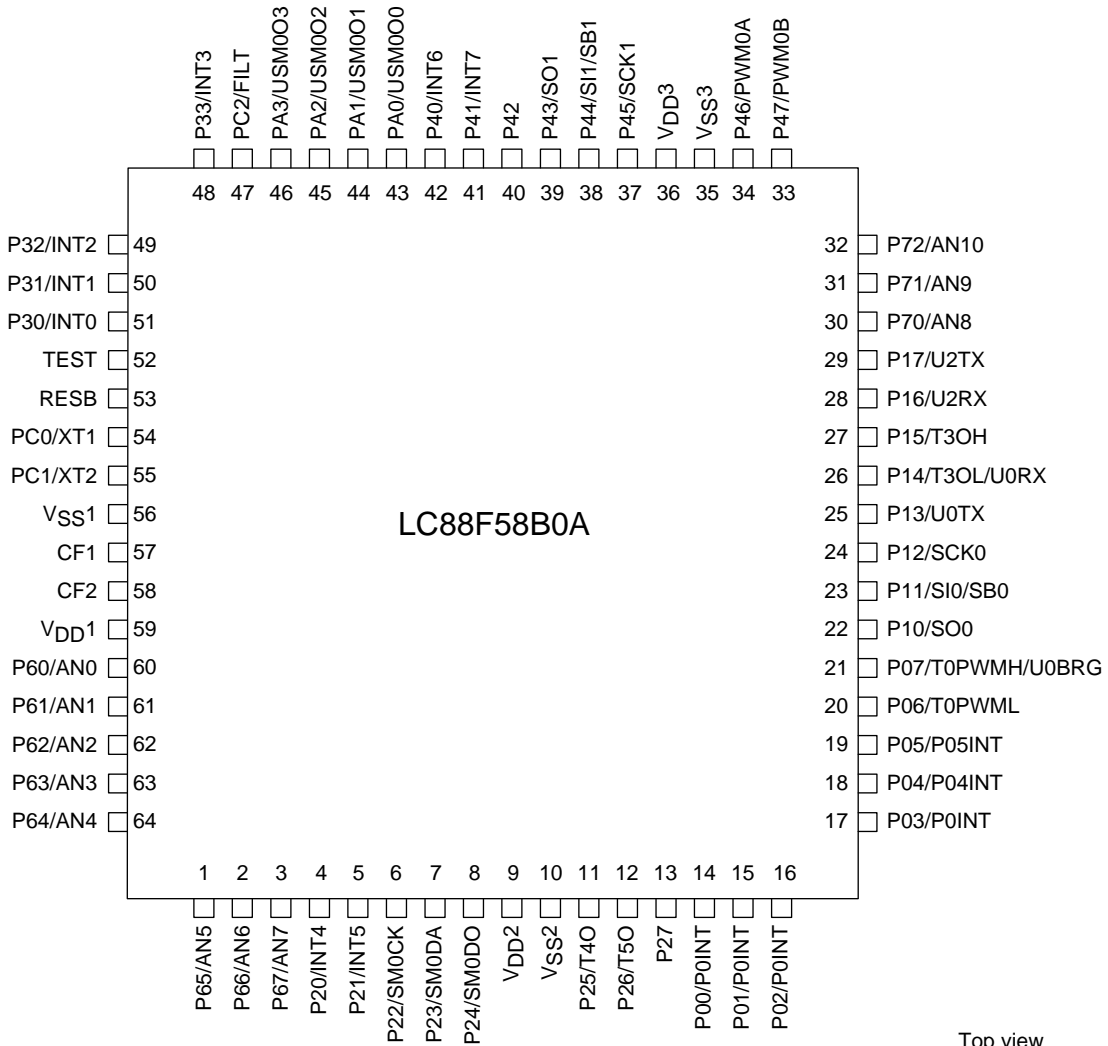

Top view

SQFP64 (10×10) (Lead-free and halogen-free type)

System Block Diagram

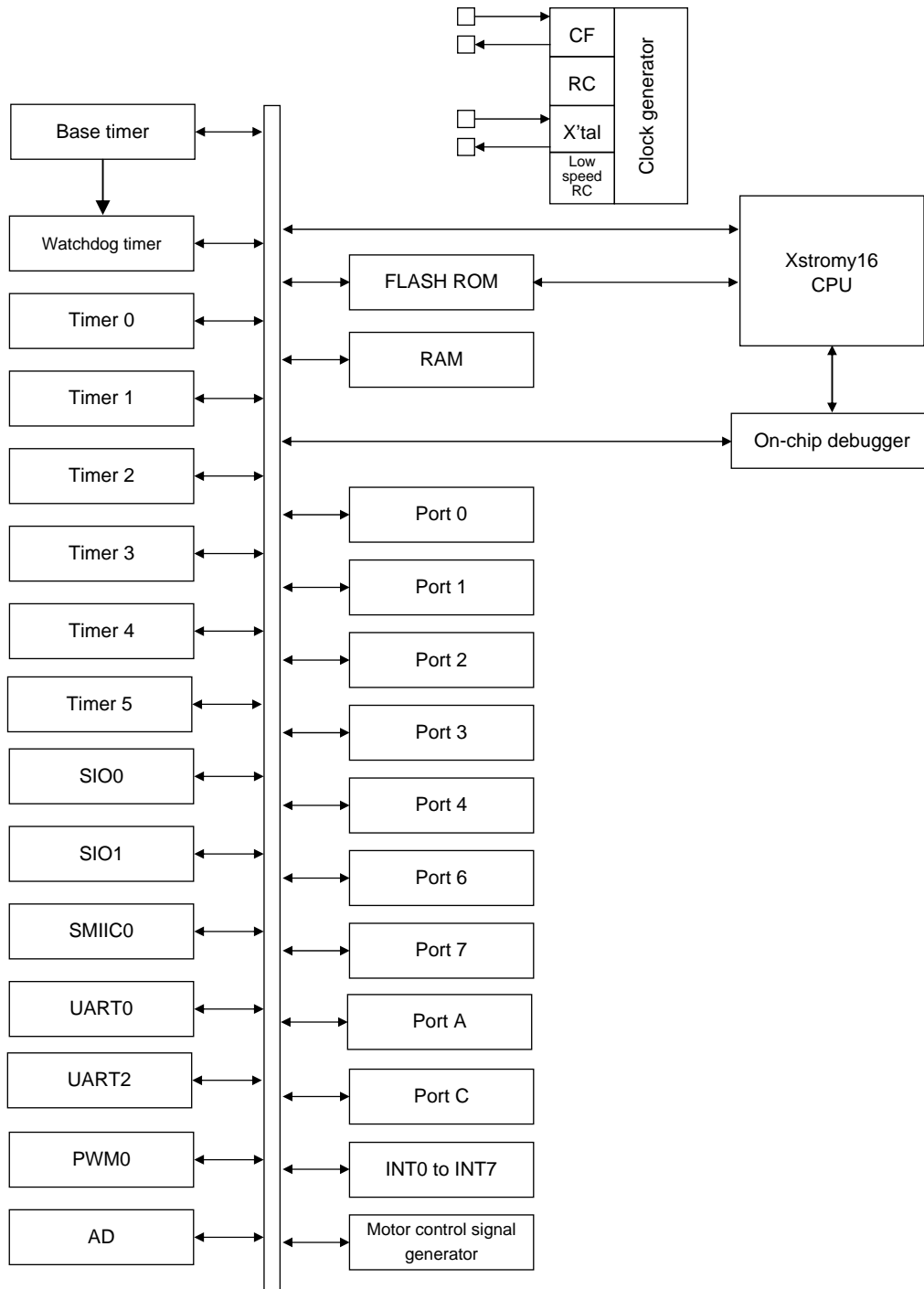

LC88F58B0A

Pin Description

Pin Name	I/O	Description
V _{SS1} , V _{SS2} , V _{SS3}	-	- Power sources
V _{DD1} , V _{DD2} , V _{DD3}	-	+ Power sources
Port 0 P00 to P07	I/O	<ul style="list-style-type: none"> • 8-bit I/O port • I/O specifiable in 1-bit units • Pull-up resistors can be turned on and off in 1 bit units • HOLD release input (P00 to P03, P04, P05) • Port 0 interrupt input (P00 to P03, P04, P05) • Pin functions <ul style="list-style-type: none"> P06: Timer 0L output P07: Timer 0L output/UART0 clock input
Port 1 P10 to P17	I/O	<ul style="list-style-type: none"> • 8-bit I/O port • I/O specifiable in 1-bit units • Pull-up resistors can be turned on and off in 1 bit units • Pin functions <ul style="list-style-type: none"> P10: SIO0 data output P11: SIO0 data input/pulse input/output P12: SIO0 clock input/output P13: UART0 transmit P14: Timer 3L output/UART0 receive P15: Timer 3H output P16: UART2 receive P17: UART2 transmit
Port 2 P20 to P27	I/O	<ul style="list-style-type: none"> • 8-bit I/O port • I/O specifiable in 1-bit units • Pull-up resistors can be turned on and off in 1 bit units • Pin functions <ul style="list-style-type: none"> P20: INT4 input/HOLD release input/timer 3 event input/timer 2L capture input/timer 2H capture input P21: INT5 input/HOLD release input/timer 3 event input/timer 2L capture input/timer 2H capture input P22: SMII0 clock input/output P23: SMII0 bus input/output/data input P24: SMII0 data output (used in 3-wire SIO mode) P25: Timer 4 output P26: Timer 5 output Interrupt acknowledge type INT4, INT5: H level, L level, H edge, L edge, both edges
Port 3 P30 to P33	I/O	<ul style="list-style-type: none"> • 4-bit I/O port • I/O specifiable in 1-bit units • Pull-up resistors can be turned on and off in 1 bit units • Pin functions <ul style="list-style-type: none"> P30: INT0 input/HOLD release/timer 2L capture input P31: INT1 input/HOLD release/timer 2H capture input P32: INT2 input/HOLD release/timer 2 event input/timer 2L capture input P33: INT3 input/HOLD release/timer 2 event input/timer 2H capture input Interrupt acknowledge type INT0 to INT3: H level, L level, H edge, L edge, both edges

Continued on next page.

LC88F58B0A

Continued from preceding page.

Pin Name	I/O	Description
Port 4 P40 to P47	I/O	<ul style="list-style-type: none"> • 8-bit I/O port • I/O specifiable in 1-bit units • Pull-up resistors can be turned on and off in 1 bit units • Pin functions P40: INT6 input/HOLD release input P41: INT7 input/HOLD release input P43: SIO1 data output P44: SIO1 data input/bus input/output P45: SIO1 clock input/output P46: PWM00 output P47: PWM01 output Interrupt acknowledge type INT6, INT7: H level, L level, H edge, L edge, both edges
Port 6 P60 to P67	I/O	<ul style="list-style-type: none"> • 8-bit I/O port • I/O specifiable in 1-bit units • Pull-up resistors can be turned on and off in 1 bit units • Pin functions AN0 (P60) to AN7 (P67): AD converter input port
Port 7 P70 to P72	I/O	<ul style="list-style-type: none"> • 3-bit I/O port • I/O specifiable in 1-bit units • Pull-up resistors can be turned on and off in 1 bit units • Pin functions AN8 (P70) to AN10 (P72): AD converter input port
Port A PA0 to PA3	I/O	<ul style="list-style-type: none"> • 4-bit I/O port • I/O specifiable in 1-bit units • Pull-up resistors can be turned on and off in 1 bit units • Multiplexed pin functions PA0: USM0 output 0 PA1: USM0 output 1 PA2: USM0 output 2 PA3: USM0 output 3
Port C PC0 to PC2	I/O	<ul style="list-style-type: none"> • 3-bit I/O port (on output: Nch-open drain (PC0 to PC1), CMOS (PC2)) • I/O specifiable in 1-bit units • Pin functions PC0: 32.768kHz crystal oscillator input PC1: 32.768kHz crystal oscillator output PC2: FILT
TEST	I/O	<ul style="list-style-type: none"> • TEST pin • Used to communicate with on-chip debugger. • Connects an external 100kΩ pull-down resistor.
RESB	I	Reset pin
CF1	I	Ceramic oscillator input pin
CF2	O	Ceramic oscillator output pin

LC88F58B0A

Port Output Types

The table below lists the types of port outputs and the presence/absence of a pull-up resistor. Data can be read into any input port even if it is in the output mode.

Port Name	Option Selected in Units of	Option Type No.	Output Type	Pull-up Resistor
P00 to P07 P10 to P17 P20 to P27 P30 to P33	1 bit	1	CMOS	Programmable
P40 to P47 P60 to P67 P70 to P72 PA0 to PA3		2	N-channel open drain	
PC2	-	-	CMOS	
PC0	-	-	N-channel open drain (32.768kHz crystal oscillator input)	None
PC1	-	-	N-channel open drain (32.768kHz crystal oscillator output)	None

* Make the following connection to minimize the noise input to the VDD1 pin and prolong the backup time. Be sure to electrically short the VSS1, VSS2 and VSS3 pins.

Example 1: When data is being backed up in the HOLD mode, the H level signals to the output ports are fed by the backup capacitors.

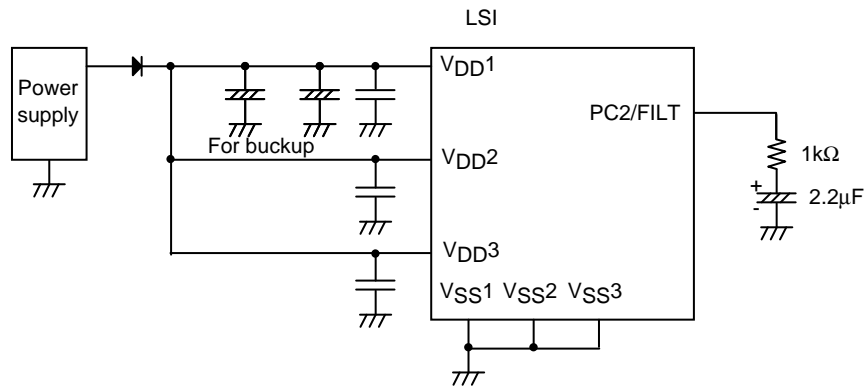

Example 2: When data is being backed up in the HOLD mode, the H level output at any ports is not sustained and is unpredictable.

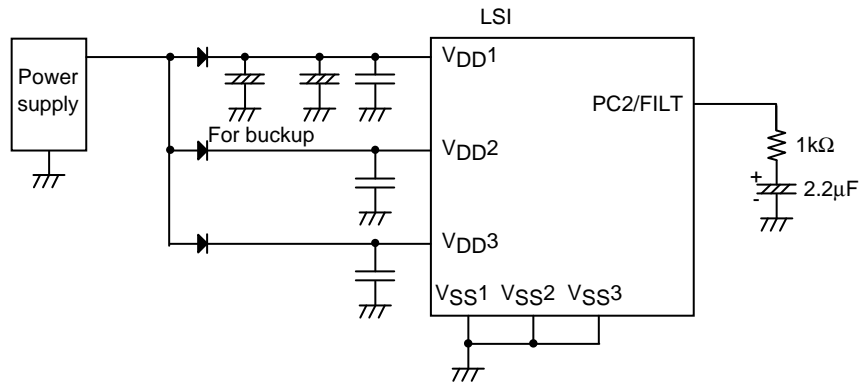

LC88F58B0A

Absolute Maximum Ratings at Ta = 25°C, VSS1 = VSS2 = VSS3 = 0V

Parameter	Symbol	Applicable Pin /Remarks	Conditions	Specification				
				VDD[V]	min	typ	max	unit
Maximum supply voltage	VDD max	VDD1, VDD2, VDD3	VDD1=VDD2=VDD3		-0.3		+6.5	V
Input voltage	VI(1)	CF1, RESB			-0.3		VDD +0.3	
Input/output voltage	VI0(1)	Ports 0, 1, 2 Ports 3, 4 Ports 6, 7 Ports A, C			-0.3		VDD +0.3	
High level output current	Peak output current	IOPH(1)	Ports 0, 1, 2 P70 to P72 P40 to P45 PA0 to PA3	CMOS output selected Per applicable pin		-10		mA
		IOPH(2)	P46, P47	Per applicable pin		-20		
		IOPH(3)	Port 6 P30 to P33 PC2	Per applicable pin		-5		
	Average output current (Note 1-1)	IOMH(1)	Ports 0, 1, 2 P70 to P72 P36 to P37 P40 to P45 PA0 to PA3	CMOS output selected Per applicable pin		-7.5		
		IOMH(2)	P46, P47	Per applicable pin		-10		
		IOMH(3)	Port 6 P30 to P33 PC2	Per applicable pin		-3		
	Total output current	ΣIOAH(1)	P30 to P33, PC2	Total of currents at applicable pins		-15		
		ΣIOAH(2)	Port 6	Total of currents at applicable pins		-15		
		ΣIOAH(3)	Port 6 P30 to P33 PC2	Total of currents at applicable pins		-20		
		ΣIOAH(4)	Ports 0, 1 P25 to P27	Total of currents at applicable pins		-25		
		ΣIOAH(5)	P20 to P24	Total of currents at applicable pins		-25		
		ΣIOAH(6)	Ports 0, 1, 2	Total of currents at applicable pins		-45		
		ΣIOAH(7)	P40 to P45 PA0 to PA3	Total of currents at applicable pins		-25		
		ΣIOAH(8)	P46 to P47 P70 to P72	Total of currents at applicable pins		-25		
		ΣIOAH(9)	Port 4 P70 to P72 PA0 to PA3	Total of currents at applicable pins		-45		

Note 1-1: Average output current refers to the average of output currents measured for a period of 100ms.

Continued on next page.

LC88F58B0A

Continued from preceding page.

Parameter	Symbol	Applicable Pin /Remarks	Conditions	Specification					
				V _{DD} [V]	min	typ	max	unit	
Low level output current	Peak output current	IOPL(1)	Ports 0, 1, 4 P70 to P72 PA0 to PA3 P20, P21, P24 to P27	Per applicable pin				20	mA
		IOPL(2)	P22, P23	Per applicable pin				25	
		IOPL(3)	P30 to P33 Port 6 PC0 to PC2	Per applicable pin				10	
	Average output current (Note 1-1)	IOML(1)	Ports 0, 1, 4 P70 to P72 PA0 to PA3 P20, P21, P24 to P27	Per applicable pin				15	
		IOML(2)	P22, P23	Per applicable pin				20	
		IOML(3)	P30 to P33 Port 6 PC0 to PC2	Per applicable pin				7.5	
	Total output current	ΣIOAL(1)	P30 to P34 PC0 to PC2	Total of currents at applicable pins				15	
		ΣIOAL(2)	Port 6	Total of currents at applicable pins				15	
		ΣIOAL(3)	Port 6 P30 to P33 PC0 to PC2	Total of currents at applicable pins				20	
		ΣIOAL(4)	Ports 0, 1 P25 to P27	Total of currents at applicable pins				45	
		ΣIOAL(5)	P20 to P24	Total of currents at applicable pins				45	
		ΣIOAL(6)	Ports 0, 1, 2	Total of currents at applicable pins				80	
ΣIOAL(7)		P40 to P45 PA0 to PA3	Total of currents at applicable pins				45		
ΣIOAL(8)		P46 to P47 P70 to P72	Total of currents at applicable pins				45		
ΣIOAL(9)		Port 4 P70 to P72 PA0 to PA3	Total of currents at applicable pins				80		
Allowable power dissipation	P _d max	SQFP64 (10×10)	T _a =-40 to +85°C				200	mW	
Operating ambient temperature	T _{opr}				-40		+85	°C	
Storage ambient temperature	T _{stg}				-55		+125		

Note 1-1: Average output current refers to the average of output currents measured for a period of 100ms.

Stresses exceeding Maximum Ratings may damage the device. Maximum Ratings are stress ratings only. Functional operation above the Recommended Operating Conditions is not implied. Extended exposure to stresses above the Recommended Operating Conditions may affect device reliability.

LC88F58B0A

Allowable Operating Conditions at Ta = -40 to +85°C, VSS1 = VSS2 = VSS3 = 0V

Parameter	Symbol	Applicable Pin /Remarks	Conditions	Specification				unit
				VDD[V]	min	typ	max	
Operating supply voltage (Note 2-1)	VDD(1)	VDD1=VDD2=VDD3	0.081μs≤tCYC≤66μs		4.5		5.5	V
			0.098μs≤tCYC≤66μs		3.0		5.5	
			0.490μs≤tCYC≤66μs		2.2		5.5	
Memory sustaining supply voltage	VHD	VDD1=VDD2=VDD3	RAM and register contents sustained in HOLD mode		2.0		5.5	
High level input voltage	VIH(1)	Ports 0, 1, 2, 3, 4 Port A		2.2 to 5.5	0.3VDD +0.7		VDD	V
	VIH(2)	Ports 6, 7, PC2		2.2 to 5.5	0.3VDD +0.7		VDD	
	VIH(3)	CF1, RESB PC0, PC1		2.2 to 5.5	0.75VDD		VDD	
	VIH(4)	P22, P23 I ² C side		2.2 to 5.5	0.7VDD		VDD	
Low level input voltage	VIL(1)	When ports 1, 2, 3, 4 and port A, PnFSAn=0		4.0 to 5.5	VSS		0.1VDD +0.4	V
	VIL(2)	Ports 0, 6, 7, PC2		2.2 to 4.0	VSS		0.2VDD	
	VIL(3)	When ports 1, 2, 3, 4 and port A, PnFSAn=1		4.0 to 5.5	VSS		0.15VDD +0.4	
	VIL(4)			2.2 to 4.0	VSS		0.2VDD	
	VIL(5)	CF1, RESB PC0, PC1		2.2 to 5.5	VSS		0.25VDD	
	VIL(6)	P22, P23 I ² C side		2.2 to 5.5	VSS		0.3VDD	
Instruction cycle time (Note 2-2)	tCYC			4.5 to 5.5	0.081		66	μs
				3.0 to 5.5	0.098		66	
				2.2 to 5.5	0.490		66	
External system clock frequency	FEXCF(1)	CF1	<ul style="list-style-type: none"> • CF2 pin open • System clock frequency division ratio=1/1 • External system clock DUTY50±5% 	4.5 to 5.5	0.1		12	MHz
				3.0 to 5.5	0.1		10	
				2.2 to 5.5	0.1		2	
				4.5 to 5.5	0.2		24	
				3.0 to 5.5	0.2		20	
				2.2 to 5.5	0.2		4	
Oscillation frequency range (Note 2-3)	FmCF(1)	CF1, CF2	12MHz ceramic oscillator mode See Fig. 1.	4.5 to 5.5		12		MHz
	FmCF(2)	CF1, CF2	10MHz ceramic oscillator mode See Fig. 1.	3.0 to 5.5		10		
	FmCF(3)	CF1, CF2	4MHz ceramic oscillator mode See Fig. 1.	2.2 to 5.5		4		
	FmRC		Internal RC oscillation	2.2 to 5.5	0.5	1.0	2.0	
	FmSLRC		Internal low-speed RC oscillation	2.2 to 5.5	18	30	45	
	FsX'tal	XT1, XT2	32.768kHz crystal oscillator mode See Fig. 2.	2.2 to 5.5		32.768		kHz

Note 2-1: VDD≥3.0V must be maintained when making onboard programming into flash ROM.

Note 2-2: Relationship between tCYC and oscillation frequency is 1/FmCF when frequency division ratio is 1/1 and 2/FmCF when the ratio is 1/2.

Note 2-3: See Tables 1 and 2 for oscillator constant values.

LC88F58B0A

Electrical Characteristics at Ta = -40 to +85°C, V_{SS1} = V_{SS2} = V_{SS3} = 0V

Parameter	Symbol	Applicable Pin /Remarks	Conditions	Specification					
				V _{DD} [V]	min	typ	max	unit	
High level input current	I _{IH} (1)	Ports 0, 1, 2 Ports 3, 4 Ports 6, 7 Ports A, C RESB	Output disabled Pull-up resistor off V _{IN} =V _{DD} (Including output Tr. off leakage current)	2.2 to 5.5			1	μA	
	I _{IH} (2)	CF1	V _{IN} =V _{DD}	2.2 to 5.5			15		
Low level input current	I _{IL} (1)	Ports 0, 1, 2 Ports 3, 4 Ports 6, 7 Ports A, C RESB	Output disabled Pull-up resistor off V _{IN} =V _{SS} (Including output Tr. off leakage current)	2.2 to 5.5		-1		μA	
	I _{IL} (2)	CF1	V _{IN} =V _{SS}	2.2 to 5.5		-15			
High level output voltage	V _{OH} (1)	Ports 0, 1, 2 PA0 to PA3 P40 to P45	I _{OH} =-1.0mA	4.5 to 5.5	V _{DD} -1			V	
	V _{OH} (2)		I _{OH} =-0.4mA	3.0 to 5.5	V _{DD} -0.4				
	V _{OH} (3)		I _{OH} =-0.2mA	2.2 to 5.5	V _{DD} -0.4				
	V _{OH} (4)	Port 6 P30 to P33 PC2	I _{OH} =-0.4mA	3.0 to 5.5	V _{DD} -0.4				
	V _{OH} (5)		I _{OH} =-0.2mA	2.2 to 5.5	V _{DD} -0.4				
	V _{OH} (6)	P46, P47	I _{OH} =-10mA	4.5 to 5.5	V _{DD} -1.5				
	V _{OH} (7)		I _{OH} =-1.6mA	3.0 to 5.5	V _{DD} -0.4				
	V _{OH} (8)		I _{OH} =-1.0mA	2.2 to 5.5	V _{DD} -0.4				
Low level output voltage	V _{OL} (1)	Ports 0, 1 Ports 4, 7 P20 to P21, P24 to P27 PA0 to PA3	I _{OL} =10mA	4.5 to 5.5			1.5	V	
	V _{OL} (2)		I _{OL} =1.6mA	3.0 to 5.5			0.4		
	V _{OL} (3)		I _{OL} =1.0mA	2.2 to 5.5			0.4		
	V _{OL} (4)	P22, P23	I _{OL} =11mA	4.5 to 5.5			1.5		
	V _{OL} (5)		I _{OL} =3.0mA	3.0 to 5.5			0.4		
	V _{OL} (6)		I _{OL} =1.3mA	2.2 to 5.5			0.4		
	V _{OL} (7)	Ports 6, C P30 to P33	I _{OL} =1.6mA	3.0 to 5.5			0.4		
	V _{OL} (8)		I _{OL} =1.0mA	2.2 to 5.5			0.4		
Pull-up resistor	R _{pu} (1)	Ports 0, 1, 2, 3 Ports 4, 6, 7 Ports A, PC2	V _{OH} =0.9V _{DD}	4.5 to 5.5		15	35	80	kΩ
	R _{pu} (2)			2.2 to 4.5		18	55	150	
Hysteresis voltage	V _{HYS}	RESB When ports 1, 2, 3, 4, A PnFSAn=1		2.2 to 5.5			0.1V _{DD}	V	
Pin capacitance	CP	All pins	Pins other than that under test V _{IN} =V _{SS} f=1MHz Ta=25°C	2.2 to 5.5			10	pF	

LC88F58B0A

Serial I/O Characteristics at Ta = -40 to +85°C, VSS1 = VSS2 = VSS3 = 0V

Serial I/O Characteristics (Wakeup Function Disabled) (Note 4-1-1)

Parameter		Symbol	Applicable Pin/Remarks	Conditions	V _{DD} [V]	Specification				
						min	typ	max	unit	
Serial clock	Input clock	Period	tSCK(1)	SCK0 (P12)	• See Fig. 6.	2.2 to 5.5	4			tCYC
		Low level pulse width	tSCKL(1)				2			
		High level pulse width	tSCKH(1)				2			
			tSCKHA(1)				6			
		tSCKHBSY(1a)	23							
		tSCKHBSY(1b)	4							
	Output clock	Period	tSCK(2)	SCK0 (P12)	• CMOS output selected • See Fig. 6.	2.2 to 5.5	4			tSCK
		Low level pulse width	tSCKL(2)				1/2		tCYC	
		High level pulse width	tSCKH(2)				1/2			
			tSCKHA(2)				6			
		tSCKHBSY(2a)	4					23		
		tSCKHBSY(2b)	4							
Serial input	Data setup time	tsDI(1)	SI0 (P11), SB0 (P11)	• Specified with respect to rising edge of SIOCLK • See Fig. 6.	2.2 to 5.5	0.03				
	Data hold time	thDI(1)				0.03				
Serial output	Output delay time	tdD0(1)	SO0 (P10), SB0 (P11)	• (Note 4-1-2)	2.2 to 5.5			1tCYC +0.05	μs	
		tdD0(2)		• (Note 4-1-2)				1tCYC +0.05		

Note 4-1-1: These specifications are theoretical values. Add margin depending on its use.

Note 4-1-2: Specified with respect to the falling edge of SIOCLK. Specified as the interval up to the time an output change begins in the open drain output mode. See Fig. 6.

LC88F58B0A

SIO0 Serial Input/Output Characteristics (Wakeup Function Enabled) (Note 4-2-1)

Parameter		Symbol	Applicable Pin/Remarks	Conditions	V _{DD} [V]	Specification				
						min	typ	max	unit	
Serial clock	Input clock	Period	tSCK(3)	SCK0 (P12)	• See Fig. 6.	2.2 to 5.5	2			tCYC
		Low level pulse width	tSCKL(3)				1			
		High level pulse width	tSCKH(3)				1			
			tSCKHBSY(3)				2			
Serial input		Data setup time	tsDI(2)	SI0 (P11), SB0 (P11)	• Specified with respect to rising edge of SIOCLK • See Fig. 6.	2.2 to 5.5	0.03			μs
		Data hold time	thDI(2)				0.03			
Serial output	Input clock	Output delay time	tdD0(3)	SO0 (P10), SB0 (P11)	• (Note 4-2-2)	2.2 to 5.5			1tCYC +0.05	

Note 4-2-1: These specifications are theoretical values. Add margin depending on its use.

Note 4-2-2: Specified with respect to the falling edge of SIOCLK. Specified as the interval up to the time an output change begins in the open drain output mode. See Fig.6.

LC88F58B0A

SIO1 Serial Input/Output Characteristics (Wakeup Function Disabled) (Note 4-3-1)

Parameter		Symbol	Applicable Pin/Remarks	Conditions	V _{DD} [V]	Specification				
						min	typ	max	unit	
Serial clock	Input clock	Period	tSCK(4)	SCK1(P45)	<ul style="list-style-type: none"> • See Fig. 6. 	2.2 to 5.5	4			tCYC
		Low level pulse width	tSCKL(4)				2			
		High level pulse width	tSCKH(4)				2			
			tSCKHA(4)							
		tSCKHBSY(4a)								
		tSCKHBSY(4b)								
	Output clock	Period	tSCK(5)	SCK1(P45)	<ul style="list-style-type: none"> • CMOS output selected • See Fig. 6. 	2.2 to 5.5	4			tSCK
		Low level pulse width	tSCKL(5)				1/2			
		High level pulse width	tSCKH(5)				1/2			
			tSCKHA(5)							
		tSCKHBSY(5a)								
		tSCKHBSY(5b)								
Serial input	Data setup time	tsDI(3)	SI1(P44), SB1(P44)	<ul style="list-style-type: none"> • Specified with respect to rising edge of SIOCLK • See Fig. 6. 	2.2 to 5.5	0.03			μs	
	Data hold time	thDI(3)				0.03				
Serial output	Output delay time	tdD0(4)	SO1(P43), SB1(P44)	<ul style="list-style-type: none"> • (Note 4-3-2) 	2.2 to 5.5			1tCYC +0.05	μs	
		tdDO(5)				<ul style="list-style-type: none"> • (Note 4-3-2) 				1tCYC +0.05

Note 4-3-1: These specifications are theoretical values. Add margin depending on its use.

Note 4-3-2: Specified with respect to the falling edge of SIOCLK. Specified as the interval up to the time an output change begins in the open drain output mode. See Fig. 6.

LC88F58B0A

SIO1 Serial Input/Output Characteristics (Wakeup Function Enabled) (Note 4-4-1)

Parameter		Symbol	Applicable Pin/Remarks	Conditions	V _{DD} [V]	Specification				
						min	typ	max	unit	
Serial clock	Input clock	Period	tSCK(6)	SCK1(P45)	• See Fig. 6.	2.2 to 5.5	2			tCYC
		Low level pulse width	tSCKL(6)				1			
		High level pulse width	tSCKH(6)				1			
			tSCKHBSY(6)				2			
Serial input	Data setup time	tsDI(4)	SI1(P44), SB1(P44)	• Specified with respect to rising edge of SIOCLK • See Fig. 6.	2.2 to 5.5	0.03			μs	
	Data hold time	thDI(4)				0.03				
Serial output	Input clock	Output delay time	tdD0(6)	SO1(P43), SB1(P44)	• (Note 4-4-2)	2.2 to 5.5				1tCYC +0.05

Note 4-4-1: These specifications are theoretical values. Add margin depending on its use.

Note 4-4-2: Specified with respect to the falling edge of SIOCLK. Specified as the interval up to the time an output change begins in the open drain output mode. See Fig. 6.

SMIIC0 Simple SIO Mode Input/Output Characteristics

Parameter		Symbol	Applicable Pin/Remarks	Conditions	V _{DD} [V]	Specification				
						min	typ	max	unit	
Serial clock	Input clock	Period	tSCK(7)	SMOCK(P22)	See Fig. 6.	2.2 to 5.5	8			tCYC
		Low level pulse width	tSCKL(7)				4			
		High level pulse width	tSCKH(7)				4			
	Output clock	Period	tSCK(8)	SMOCK(P22)	• CMOS output selected • See Fig. 6.	2.2 to 5.5	8			tSCK
		Low level pulse width	tSCKL(8)				1/2			
		High level pulse width	tSCKH(8)				1/2			
Serial input	Data setup time	tsDI(5)	SM0DA(P23)	• Specified with respect to rising edge of SIOCLK • See Fig. 6.	2.2 to 5.5	0.03			μs	
	Data hold time	thDI(5)				0.03				
Serial output	Output delay time	tdD0(7)	SM0DO(P24), SM0DA(P23)	• Specified with respect to falling edge of SIOCLK • Specified as interval up to time when output state starts changing. • See Fig. 6.	2.2 to 5.5			1tCYC +0.05		

Note 4-5-1: These specifications are theoretical values. Add margin depending on its use.

LC88F58B0A

SMIIC0 I²C Mode Input/Output Characteristics

Parameter		Symbol	Applicable Pin/Remarks	Conditions	V _{DD} [V]	Specification				
						min	typ	max	unit	
Clock	Input clock	Period	tSCL	SM0CK(P22)	• See Fig. 8.	2.2 to 5.5	5			Tfilt
		Low level pulse width	tSCLL				2.5			
		High level pulse width	tSCLH				2			
	Output clock	Period	tSCLx	SM0CK(P22)	• Specified as interval up to time when output state starts changing.	2.2 to 5.5	10			tSCL
		Low level pulse width	tSCLLx				1/2			
		High level pulse width	tSCLHx				1/2			
SM0CK and SM0DA pins input spike suppression time		tsp	SM0CK(P22) SM0DA(P23)	• See Fig. 8.				1	Tfilt	
Bus release time between start and stop	Input	tBUF	SM0CK(P22) SM0DA(P23)	• See Fig. 8.	2.2 to 5.5	2.5			Tfilt	
	Output	tBUFx	SM0CK(P22) SM0DA(P23)	<ul style="list-style-type: none"> • Standard clock mode • Specified as interval up to time when output state starts changing. • High-speed clock mode • Specified as interval up to time when output state starts changing. 		5.5			μs	
Start/restart condition hold time	Input	tHD;STA	SM0CK(P22) SM0DA(P23)	<ul style="list-style-type: none"> • When SMIIC register control bit, I²CSHDS=0 • See Fig. 8. 	2.2 to 5.5	2.0			Tfilt	
				<ul style="list-style-type: none"> • When SMIIC register control bit, I²CSHDS=1 • See Fig. 8. 		2.5				
	Output	tHD;STAx	SM0CK(P22) SM0DA(P23)	<ul style="list-style-type: none"> • Standard clock mode • Specified as interval up to time when output state starts changing. 	4.1			μs		
				<ul style="list-style-type: none"> • High-speed clock mode • Specified as interval up to time when output state starts changing. 	1.0					
Restart condition setup time	Input	tSU;STA	SM0CK(P22) SM0DA(P23)	• See Fig. 8.	2.2 to 5.5	1.0			Tfilt	
	Output	tSU;STAx	SM0CK(P22) SM0DA(P23)	<ul style="list-style-type: none"> • Standard clock mode • Specified as interval up to time when output state starts changing. • High-speed clock mode • Specified as interval up to time when output state starts changing. 		5.5			μs	

Continued on next page.

LC88F58B0A

Continued from preceding page

Parameter	Symbol	Applicable Pin/Remarks	Conditions	V _{DD} [V]	Specification				
					min	typ	max	unit	
Stop condition setup time	Input	tSU;STO	SM0CK(P22) SM0DA(P23)	• See Fig. 8.	2.2 to 5.5	1.0			Tfilt
	Output	tSU;STOx	SM0CK(P22) SM0DA(P23)	<ul style="list-style-type: none"> • Standard clock mode • Specified as interval up to time when output state starts changing. • High-speed clock mode • Specified as interval up to time when output state starts changing. 		4.9			μs
						1.1			
Data hold time	Input	tHD;DAT	SM0CK(P22) SM0DA(P23)	• See Fig. 8.	2.2 to 5.5	0			Tfilt
	Output	tHD;DATx	SM0CK(P22) SM0DA(P23)	• Specified as interval up to time when output state starts changing.		1		1.5	
Data setup time	Input	tSU;DAT	SM0CK(P22) SM0DA(P23)	• See Fig. 8.	2.2 to 5.5	1			Tfilt
	Output	tSU;DATx	SM0CK(P22) SM0DA(P23)	• Specified as interval up to time when output state starts changing.		tSCL -1.5Tfilt			
SM0CK and SM0DA pins fall time	Input	tF	SM0CK(P22) SM0DA(P23)	• See Fig. 8.	2.2 to 5.5			300	ns
	Output	tF	SM0CK (P22) SM0DA (P23)	<ul style="list-style-type: none"> • When SMIIC register control bits, PSLW=1, P5V=1 • When SMIIC register control bits, PSLW=1, P5V=0 • SM0CK, SM0DA port output FAST mode • Cb≤400pF 	5	20 +0.1Cb	250		
					3	20 +0.1Cb	250		
					3 to 5.5		100		

Note 4-6-1: These specifications are theoretical values. Add margin depending on its use.

Note 4-6-2: The value of Tfilt is determined by the values of the register SMIC0BRG, bits 7 and 6 (BRP1, BRP0) and the system clock frequency.

BRP1	BRP0	Tfilt
0	0	tCYC×1
0	1	tCYC×2
1	0	tCYC×3
1	1	tCYC×4

Set bits (BRP1, BRP0) so that the value of Tfilt falls between the following range:
 $250\text{ns} \geq \text{Tfilt} > 140\text{ns}$

Note 4-6-3: Cb represents the total loads (in pF) connected to the bus pins. $C_b \leq 400\text{pF}$

Note 4-6-4: The standard clock mode refers to a mode that is entered by configuring SMIC0BRG as follows:

$250\text{ns} \geq \text{Tfilt} > 140\text{ns}$
 BRDQ (bit5) = 1
 SCL frequency setting $\leq 100\text{kHz}$

The high-speed clock mode refers to a mode that is entered by configuring SMIC0BRG as follows:

$250\text{ns} \geq \text{Tfilt} > 140\text{ns}$
 BRDQ (bit5) = 0
 SCL frequency setting $\leq 400\text{kHz}$

LC88F58B0A

UART2 Operating Conditions at Ta = -40 to +85°C, VSS1 = VSS2 = VSS3 = 0V

Parameter	Symbol	Applicable Pin/Remarks	Conditions	Specification				
				V _{DD} [V]	min	typ	max	unit
Transfer rate	UBR2	U2RX(P16), U2TX(P17)		2.2 to 5.5	8		4096	tBGCYC

Note 4-7: tBGCYC denotes one cycle of the baudrate clock source.

UART0 Operating Conditions at Ta = -40 to +85°C, VSS1 = VSS2 = VSS3 = 0V

Parameter	Symbol	Applicable Pin/Remarks	Conditions	Specification				
				V _{DD} [V]	min	typ	max	unit
Transfer rate	UBR0	U0RX(P13), U0TX(P14), U0BRG(P07)		2.2 to 5.5	4		8	tBGCYC

Note 4-8: tBGCYC denotes one cycle of the baudrate clock source.

Pulse Input Conditions at Ta = -40 to +85°C, VSS1 = VSS2 = VSS3 = 0V

Parameter	Symbol	Applicable Pin/Remarks	Conditions	Specification				
				V _{DD} [V]	min	typ	max	unit
High/low level pulse width	tPIH(1) tPIL(1)	INT0(P30), INT1(P31), INT2(P32), INT3(P33), INT4(P20), INT5(P21), INT6(P40), INT7(P41)	<ul style="list-style-type: none"> • Interrupt source flag can be set. • Event inputs for timers 2 and 3 are enabled. 	2.2 to 5.5	2			tCYC
	tPIL(2)	RESB	Resetting is enabled.	2.2 to 5.5	10			μs

LC88F58B0A

AD Converter Characteristics at Ta = -40 to +85°C, VSS1 = VSS2 = VSS3 = 0V

12-bit AD Conversion Mode

Parameter	Symbol	Applicable Pin /Remarks	Conditions	Specification				
				VDD[V]	min	typ	max	unit
Resolution	NAD	AN0(P60) to AN7(P67), AN8(P70) to AN11(P72)		2.9 to 5.5		12		bit
Absolute accuracy	ETAD		(Note 6-1)	2.9 to 5.5			±16	LSB
Conversion time	TCAD12		Conversion time calculated	4.7 to 5.5	17		209	μs
				4.0 to 5.5	27		209	
				2.9 to 5.5	67		209	
Analog input voltage range	VAIN			2.9 to 5.5	VSS		VDD	V
Analog port input current	IAINH		VAIN=VDD	2.9 to 5.5			1	μA
	IAINL	VAIN=VSS	2.9 to 5.5	-1				

Conversion time calculation formula: TCAD12= ((52/(AD division ratio))+2) × tCYC

8-bit AD Conversion Mode

Parameter	Symbol	Applicable Pin /Remarks	Conditions	Specification				
				VDD[V]	min	typ	max	unit
Resolution	NAD	AN0(P60) to AN7(P67), AN8(P70) to AN11(P72)		2.9 to 5.5		8		bit
Absolute accuracy	ETAD		(Note 6-1)	2.9 to 5.5			±1.5	LSB
Conversion time	TCAD8		Conversion time calculated	4.7 to 5.5	11		129	μs
				4.0 to 5.5	17		129	
				2.9 to 5.5	42		129	
Analog input voltage range	VAIN			2.9 to 5.5	VSS		VDD	V
Analog port input current	IAINH		VAIN=VDD	2.9 to 5.5			1	μA
	IAINL	VAIN=VSS	2.9 to 5.5	-1				

Conversion time calculation formula: TCAD8= ((32/(AD division ratio))+2) × tCYC

Note 6-1: The quantization error ($\pm 1/2\text{LSB}$) is excluded from the absolute accuracy.

Note 6-2: The conversion time refers to the interval from the time a conversion starting instruction is issued till the time the complete digital value against the analog input value is loaded in the result register.

The conversion time is twice the normal value when one of the following conditions occurs:

- The first AD conversion is executed in the 12-bit AD conversion mode after a system reset.
- The first AD conversion is executed after the AD conversion mode is switched from 8-bit to 12-bit AD conversion mode.

LC88F58B0A

Consumption Current Characteristics at Ta=-40 to +85°C, VSS1=VSS2=VSS3=0V

typ: 5.0V (VDD=4.5V to 5.5V), 3.3V (VDD=3.0V to 4.5V, 2.2V to 4.5V)

Parameter	Symbol	Applicable Pin/Remarks	Conditions	Specification				
				VDD[V]	min	typ	max	unit
Normal mode consumption current (Note 7-1)	IDDOP(1)	VDD1 = VDD2 = VDD3	<ul style="list-style-type: none"> FmCF=12MHz ceramic oscillation mode FmX'tal=32.768kHz crystal oscillation mode System clock set to 12MHz Internal RC oscillation stopped 1/1 frequency division mode 	4.5 to 5.5		9.3	15.0	mA
	IDDOP(2)		<ul style="list-style-type: none"> FmCF=10MHz ceramic oscillator mode FmX'tal=32.768kHz crystal oscillator mode System clock set to 10MHz Internal RC oscillation stopped 1/1 frequency division mode 	4.5 to 5.5		8.5	14.4	
	IDDOP(3)		<ul style="list-style-type: none"> FmCF=10MHz ceramic oscillator mode FmX'tal=32.768kHz crystal oscillator mode System clock set to 10MHz Internal RC oscillation stopped 1/1 frequency division mode 	3.0 to 4.5		5.0	8.3	
	IDDOP(4)		<ul style="list-style-type: none"> FmCF=4MHz ceramic oscillator mode FmX'tal=32.768kHz crystal oscillator mode System clock set to 4MHz Internal RC oscillation stopped 1/2 frequency division mode 	4.5 to 5.5		3.8	5.6	
	IDDOP(5)		<ul style="list-style-type: none"> FmCF=4MHz ceramic oscillator mode FmX'tal=32.768kHz crystal oscillator mode System clock set to 4MHz Internal RC oscillation stopped 1/2 frequency division mode 	2.2 to 4.5		2.5	4.6	
	IDDOP(6)		<ul style="list-style-type: none"> FmCF=0Hz (oscillation stopped) FmX'tal=32.768kHz crystal oscillator mode System clock set to internal RC oscillation 1/1 frequency division mode 	4.5 to 5.5		2.5	5.6	
	IDDOP(7)		<ul style="list-style-type: none"> FmCF=0Hz (oscillation stopped) FmX'tal=32.768kHz crystal oscillator mode System clock set to internal RC oscillation 1/1 frequency division mode 	2.2 to 4.5		1.7	4.6	
	IDDOP(8)		<ul style="list-style-type: none"> FmCF=0Hz (oscillation stopped) FmX'tal=32.768kHz crystal oscillator mode System clock set to 32.768kHz Internal RC oscillation stopped 1/1 frequency division mode 	4.5 to 5.5		63	155	μA
	IDDOP(9)		<ul style="list-style-type: none"> FmCF=0Hz (oscillation stopped) FmX'tal=32.768kHz crystal oscillator mode System clock set to 32.768kHz Internal RC oscillation stopped 1/1 frequency division mode 	2.2 to 4.5		39	102	
	IDDOP(10)		<ul style="list-style-type: none"> FmCF=12MHz ceramic oscillation mode FmX'tal=32.768kHz crystal oscillation mode System clock set to 12MHz Internal RC oscillation stopped PLL oscillation mode 1/1 frequency division mode 	4.5 to 5.5		11.0	17.5	mA
	IDDOP(11)		<ul style="list-style-type: none"> FmCF=10MHz ceramic oscillation mode FmX'tal=32.768kHz crystal oscillation mode System clock set to 10MHz Internal RC oscillation stopped PLL oscillation mode 1/1 frequency division mode 	4.5 to 5.5		10.3	17.0	
	IDDOP(12)		<ul style="list-style-type: none"> FmCF=10MHz ceramic oscillation mode FmX'tal=32.768kHz crystal oscillation mode System clock set to 10MHz Internal RC oscillation stopped PLL oscillation mode 1/1 frequency division mode 	3.0 to 4.5		5.9	13.0	

Note 7-1: The consumption current value includes none of the currents that flow into the output transistor and internal pull-up resistors.

Continued on next page.

LC88F58B0A

Continued from preceding page.

Parameter	Symbol	Applicable Pin/Remarks	Conditions	Specification					
				V _{DD} [V]	min	typ	max	unit	
HALT mode consumption current (Note 7-1)	IDDHALT(1)	V _{DD1} =V _{DD2} =V _{DD3}	<ul style="list-style-type: none"> • HALT mode • FmCF=12MHz ceramic mode • FmX'tal=32.768kHz crystal oscillation mode • System clock set to 12MHz • Internal RC oscillation stopped • 1/1 frequency division mode 	4.5 to 5.5		2.9	4.4	mA	
	IDDHALT(2)		<ul style="list-style-type: none"> • HALT mode • FmCF=10MHz ceramic oscillator mode • FmX'tal=32.768kHz crystal oscillator mode • System clock set to 10MHz • Internal RC oscillation stopped • 1/1 frequency division mode 	4.5 to 5.5		2.5	4.2		
	IDDHALT(3)		<ul style="list-style-type: none"> • HALT mode • FmCF=10MHz ceramic oscillator mode • FmX'tal=32.768kHz crystal oscillator mode • System clock set to 10MHz • Internal RC oscillation stopped • 1/1 frequency division mode 	3.0 to 4.5		1.3	3.0		
	IDDHALT(4)		<ul style="list-style-type: none"> • HALT mode • FmCF=4MHz ceramic oscillator mode • FmX'tal=32.768kHz crystal oscillator mode • System clock set to 4MHz • Internal RC oscillation stopped • 1/2 frequency division mode 	4.5 to 5.5		0.90	1.6		
	IDDHALT(5)		<ul style="list-style-type: none"> • HALT mode • FmCF=4MHz ceramic oscillator mode • FmX'tal=32.768kHz crystal oscillator mode • System clock set to 4MHz • Internal RC oscillation stopped • 1/2 frequency division mode 	2.2 to 4.5		0.40	1.1		
	IDDHALT(6)		<ul style="list-style-type: none"> • HALT mode • FmCF=0Hz (oscillation stopped) • FmX'tal=32.768kHz crystal oscillator mode • System clock set to internal RC oscillation • 1/1 frequency division mode 	4.5 to 5.5		0.42	1.25		
	IDDHALT(7)		<ul style="list-style-type: none"> • HALT mode • FmCF=0Hz (oscillation stopped) • FmX'tal=32.768kHz crystal oscillator mode • System clock set to internal RC oscillation • 1/1 frequency division mode 	2.2 to 4.5		0.20	0.85		
	IDDHALT(8)		<ul style="list-style-type: none"> • HALT mode • FmCF=0Hz (oscillation stopped) • FmX'tal=32.768kHz crystal oscillator mode • System clock set to 32.768kHz • Internal RC oscillation stopped • 1/1 frequency division mode 	4.5 to 5.5		23	90		μA
	IDDHALT(9)		<ul style="list-style-type: none"> • HALT mode • FmCF=0Hz (oscillation stopped) • FmX'tal=32.768kHz crystal oscillator mode • System clock set to 32.768kHz • Internal RC oscillation stopped • 1/1 frequency division mode 	2.2 to 4.5		10	40		
HOLD mode consumption current	IDDHOLD(1)	V _{DD1}	<ul style="list-style-type: none"> • HOLD mode • CF1=V_{DD} or open (external clock mode) 	4.5 to 5.5		0.05	20	μA	
	IDDHOLD(2)		<ul style="list-style-type: none"> • HOLD mode • CF1=V_{DD} or open (external clock mode) 	2.2 to 4.5		0.03	15		
HOLDX mode consumption current	IDDHOLD(3)		<ul style="list-style-type: none"> • HOLDX mode • CF1=V_{DD} or open (external clock mode) 	4.5 to 5.5		15	58		
	IDDHOLD(4)		<ul style="list-style-type: none"> • HOLDX mode • CF1=V_{DD} or open (external clock mode) • FmX'tal=32.768kHz crystal oscillator mode 	2.2 to 4.5		4	35		

Note 7-1: The consumption current value includes none of the currents that flow into the output transistor and internal pull-up resistors.

LC88F58B0A

F-ROM Programming Characteristics at $T_a = +10$ to $+55^\circ\text{C}$, $V_{SS1}=V_{SS2}=V_{SS3}=0\text{V}$

Parameter	Symbol	Applicable Pin/Remarks	Conditions	Specification				
				$V_{DD}[\text{V}]$	min	typ	max	unit
Onboard programming current	$I_{DDFW}(1)$	V_{DD1}	• Microcontroller erase current current is excluded.	3.0 to 5.5		5	10	mA
Onboard programming time	$t_{FW}(1)$		• 128-/1K-byte erase operation	3.0 to 5.5		20	30	ms
	$t_{FW}(2)$		• 2-byte programming operation	3.0 to 5.5		40	60	μs

Power Pin Treatment Conditions 1 (V_{DD1} , V_{SS1})

Connect capacitors that meet the following conditions between the V_{DD1} and V_{SS1} pins:

- Connect among the V_{DD1} and V_{SS1} pins and the capacitors $C1$ and $C2$ with the shortest possible lead wires, of the same length ($L1=L1'$, $L2=L2'$) wherever possible.
- Connect a large-capacity capacitor $C1$ and a small-capacity capacitor $C2$ in parallel.
- The capacitance of $C2$ should be approximately $0.1\mu\text{F}$ or larger.
- The V_{DD1} and V_{SS1} traces must be thicker than the other traces.

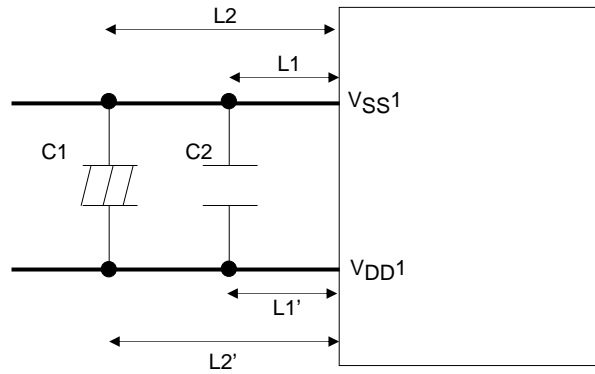

Power Pin Treatment Conditions 2 ($V_{DD}(2, 3)$, $V_{SS}(2, 3)$)

Connect capacitors that meet the following condition between the $V_{DD}(2, 3)$ and $V_{SS}(2, 3)$ pins:

- Connect among the $V_{DD}(2, 3)$ and $V_{SS}(2, 3)$ pins and the capacitor $C3$ with the shortest possible lead wires, of the same length ($L3=L3'$) wherever possible.
- The capacitance of $C3$ should be approximately $0.1\mu\text{F}$ or larger.
- The $V_{DD}(2, 3)$ and $V_{SS}(2, 3)$ traces must be thicker than the other traces.

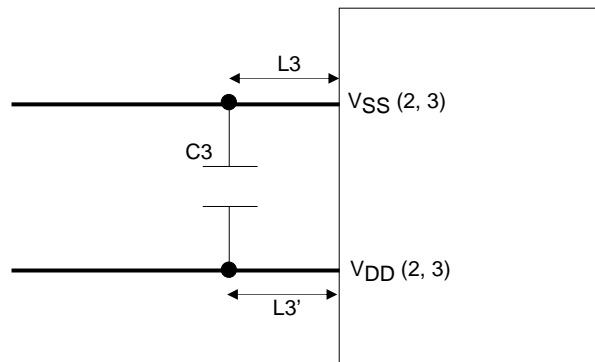

LC88F58B0A

Characteristics of a Sample Main System Clock Oscillation Circuit

Given below are the characteristics of a sample main system clock oscillation circuit that are measured using a Our designated oscillation characteristics evaluation board and external components with circuit constant values with which the oscillator vendor confirmed normal and stable oscillation.

Table 1 Characteristics of a Sample Main System Clock Oscillator Circuit with a Ceramic Resonator

Nominal Frequency	Vendor Name	Resonator	Circuit Constant				Operating Voltage Range [V]	Oscillation Stabilization Time		Remarks
			C3 [pF]	C4 [pF]	Rf [Ω]	Rd2 [Ω]		typ [ms]	max [ms]	
12MHz	MURATA	CSTCE12M0G52-R0	(10)	(10)	OPEN	220	2.4 to 5.5	0.02	0.2	C1, C2 integrated type
10MHz		CSTCE10M0G52-R0	(10)	(10)	OPEN	470	2.4 to 5.5	0.02	0.2	C1, C2 integrated type
		CSTLS10M0G53-B0	(15)	(15)	OPEN	680	2.6 to 5.5	0.02	0.2	C1, C2 integrated type
8MHz		CSTCE8M0G52-R0	(10)	(10)	OPEN	470	2.3 to 5.5	0.02	0.2	C1, C2 integrated type
		CSTLS8M0G53-B0	(15)	(15)	OPEN	1k	2.5 to 5.5	0.02	0.2	C1, C2 integrated type
4MHz		CSTCR4M0G53-R0	(15)	(15)	OPEN	1.5k	2.2 to 5.5	0.02	0.2	C1, C2 integrated type
		CSTLS4M0G53-B0	(15)	(15)	OPEN	1.5k	2.3 to 5.5	0.02	0.2	C1, C2 integrated type

The oscillation stabilization time refers to the time interval that is required for the oscillation to get stabilized after V_{DD} goes above the lower limit level of the operating voltage range (see Figure 4)

Characteristics of a Sample Subsystem Clock Oscillator Circuit

Given below are the characteristics of a sample subsystem clock oscillation circuit that are measured using a Our designated oscillation characteristics evaluation board and external components with circuit constant values with which the oscillator vendor confirmed normal and stable oscillation.

Table 2 Characteristics of a Sample Subsystem Clock Oscillator Circuit with a Crystal Resonator

Nominal Frequency	Vendor Name	Oscillator Name	Circuit Constant				Operating Voltage Range [V]	Oscillation Stabilization Time		Remarks
			C3 [pF]	C4 [pF]	Rf2 [Ω]	Rd2 [Ω]		typ [s]	max [s]	
32.768kHz	EPSON TOYOCOM	MC-306	10	10	OPEN	0	2.2 to 5.5	0.4	2.0	Applicable CL value=7.0pF

The oscillation stabilization time refers to the time interval that is required for the oscillation to get stabilized after the instruction for starting the subclock oscillator circuit is executed plus the time interval that is required for the oscillation to get stabilized after the HOLD mode is released (see Figure 4).

Note: The traces to and from the components that are involved in oscillation should be kept as short as possible as the oscillation characteristics are affected by their trace pattern.

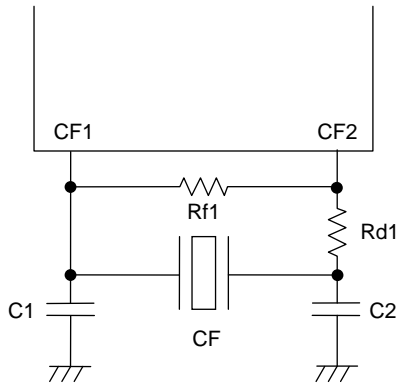

Figure 1 CF Oscillator Circuit

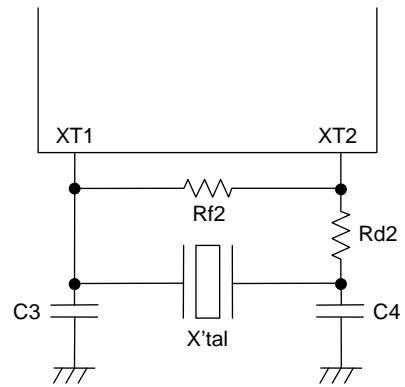

Figure 2 XT Oscillator Circuit

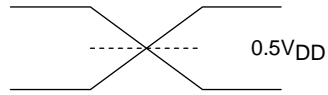
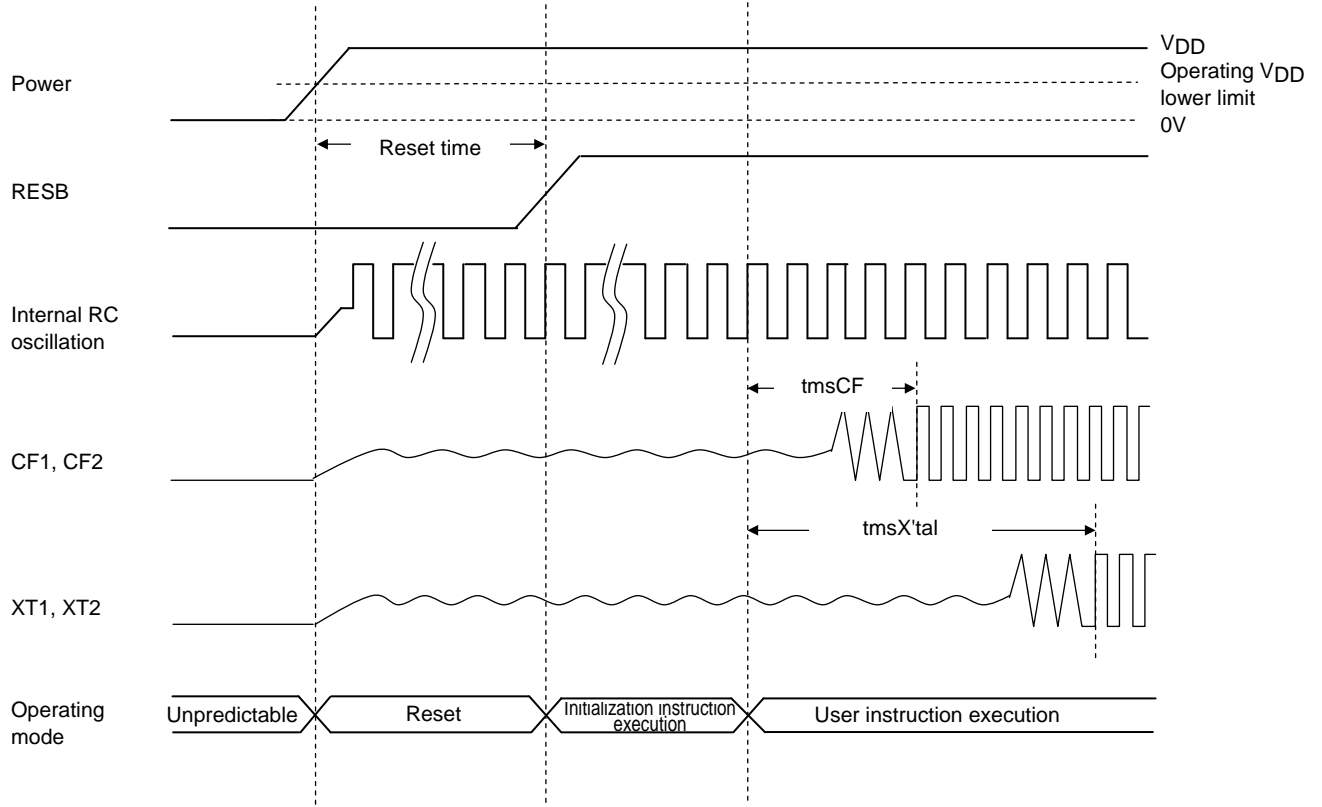
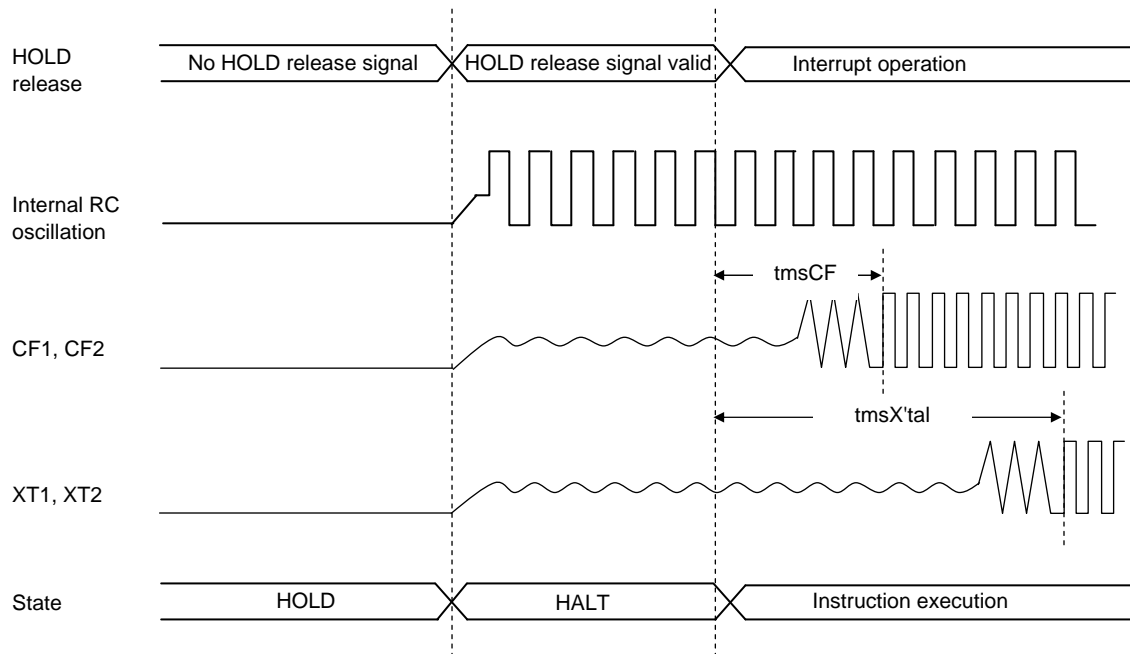

Figure 3 AC Timing Measurement Point

LC88F58B0A



Reset Time and Oscillation Stabilization Time



HOLD Release and Oscillation Stabilization Time

Figure 4 Oscillation Stabilization Time Timing Charts

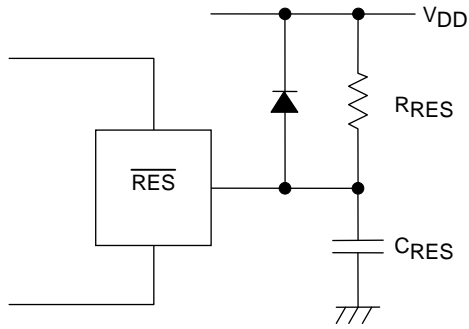

Note:
 Reset signal must be present when power supply rises.
 Determine the value of C_{RES} and R_{RES} so that the reset signal is present for $10\mu s$ after the supply voltage gets stabilized.

Figure 5 Reset Circuit

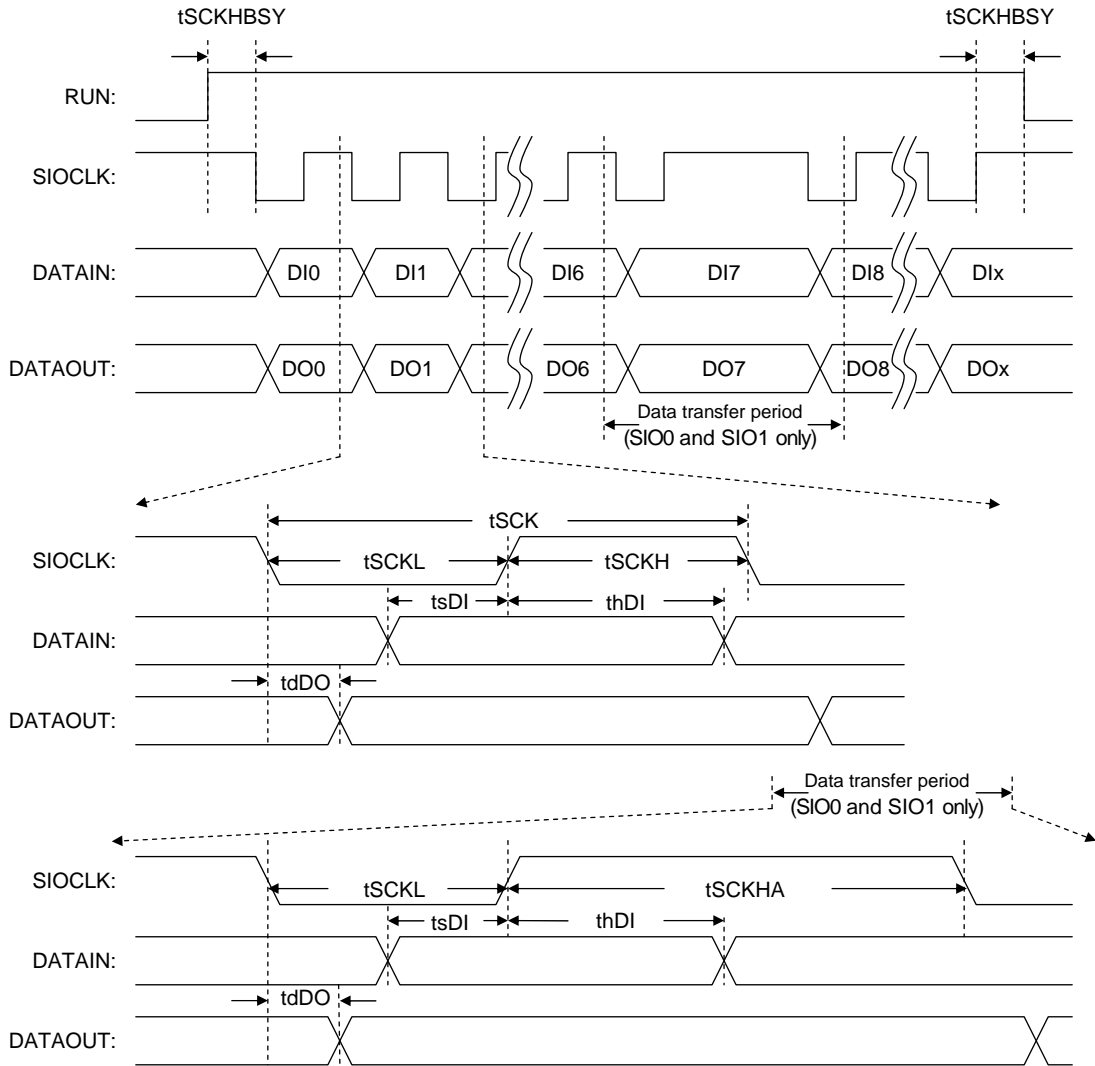

* Remarks: DIx and DOx denote the last bits communicated; x = 0 to 32768

Figure 6 Serial I/O Waveforms

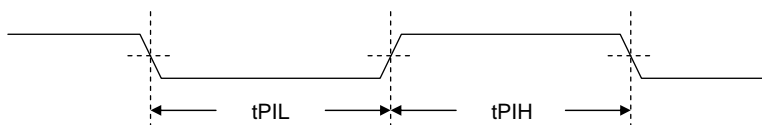
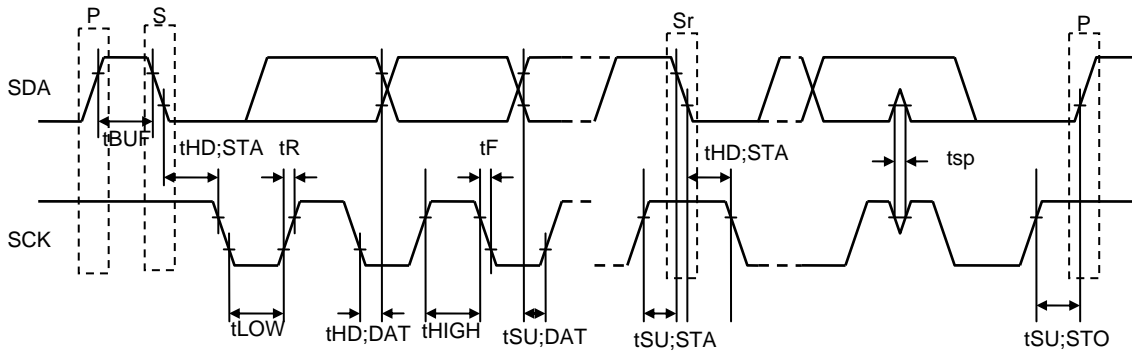

Figure 7 Pulse Input Timing Signal Waveform



S: Start condition
 P: Stop condition
 Sr: Restart condition

Figure 8 I²C Timing

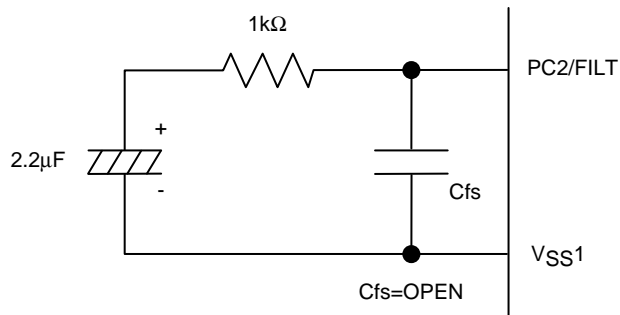

Figure 9 Recommended FILT Circuit

* Take at least 50ms to oscillation to stabilize after PLL is started.

ON Semiconductor and the ON logo are registered trademarks of Semiconductor Components Industries, LLC (SCILLC). SCILLC owns the rights to a number of patents, trademarks, copyrights, trade secrets, and other intellectual property. A listing of SCILLC's product/patent coverage may be accessed at www.onsemi.com/site/pdf/Patent-Marking.pdf. SCILLC reserves the right to make changes without further notice to any products herein. SCILLC makes no warranty, representation or guarantee regarding the suitability of its products for any particular purpose, nor does SCILLC assume any liability arising out of the application or use of any product or circuit, and specifically disclaims any and all liability, including without limitation special, consequential or incidental damages. "Typical" parameters which may be provided in SCILLC data sheets and/or specifications can and do vary in different applications and actual performance may vary over time. All operating parameters, including "Typicals" must be validated for each customer application by customer's technical experts. SCILLC does not convey any license under its patent rights nor the rights of others. SCILLC products are not designed, intended, or authorized for use as components in systems intended for surgical implant into the body, or other applications intended to support or sustain life, or for any other application in which the failure of the SCILLC product could create a situation where personal injury or death may occur. Should Buyer purchase or use SCILLC products for any such unintended or unauthorized application, Buyer shall indemnify and hold SCILLC and its officers, employees, subsidiaries, affiliates, and distributors harmless against all claims, costs, damages, and expenses, and reasonable attorney fees arising out of, directly or indirectly, any claim of personal injury or death associated with such unintended or unauthorized use, even if such claim alleges that SCILLC was negligent regarding the design or manufacture of the part. SCILLC is an Equal Opportunity/Affirmative Action Employer. This literature is subject to all applicable copyright laws and is not for resale in any manner.

Компания «Океан Электроники» предлагает заключение долгосрочных отношений при поставках импортных электронных компонентов на взаимовыгодных условиях!

Наши преимущества:

- Поставка оригинальных импортных электронных компонентов напрямую с производств Америки, Европы и Азии, а так же с крупнейших складов мира;
- Широкая линейка поставок активных и пассивных импортных электронных компонентов (более 30 млн. наименований);
- Поставка сложных, дефицитных, либо снятых с производства позиций;
- Оперативные сроки поставки под заказ (от 5 рабочих дней);
- Экспресс доставка в любую точку России;
- Помощь Конструкторского Отдела и консультации квалифицированных инженеров;
- Техническая поддержка проекта, помощь в подборе аналогов, поставка прототипов;
- Поставка электронных компонентов под контролем ВП;
- Система менеджмента качества сертифицирована по Международному стандарту ISO 9001;
- При необходимости вся продукция военного и аэрокосмического назначения проходит испытания и сертификацию в лаборатории (по согласованию с заказчиком);
- Поставка специализированных компонентов военного и аэрокосмического уровня качества (Xilinx, Altera, Analog Devices, Intersil, Interpoint, Microsemi, Actel, Aeroflex, Peregrine, VPT, Syfer, Eurofarad, Texas Instruments, MS Kennedy, Miteq, Cobham, E2V, MA-COM, Hittite, Mini-Circuits, General Dynamics и др.);

Компания «Океан Электроники» является официальным дистрибьютором и эксклюзивным представителем в России одного из крупнейших производителей разъемов военного и аэрокосмического назначения «JONHON», а так же официальным дистрибьютором и эксклюзивным представителем в России производителя высокотехнологичных и надежных решений для передачи СВЧ сигналов «FORSTAR».



JONHON

«JONHON» (основан в 1970 г.)

Разъемы специального, военного и аэрокосмического назначения:

(Применяются в военной, авиационной, аэрокосмической, морской, железнодорожной, горно- и нефтедобывающей отраслях промышленности)

«FORSTAR» (основан в 1998 г.)

ВЧ соединители, коаксиальные кабели, кабельные сборки и микроволновые компоненты:

(Применяются в телекоммуникациях гражданского и специального назначения, в средствах связи, РЛС, а так же военной, авиационной и аэрокосмической отраслях промышленности).



Телефон: 8 (812) 309-75-97 (многоканальный)

Факс: 8 (812) 320-03-32

Электронная почта: ocean@oceanchips.ru

Web: <http://oceanchips.ru/>

Адрес: 198099, г. Санкт-Петербург, ул. Калинина, д. 2, корп. 4, лит. А