

## PCI-EXPRESS GEN 3 DUAL OUTPUT CLOCK GENERATOR

### Features

- PCI-Express Gen 1, Gen 2, and Gen 3 common clock compliant
- Gen 3 SRNS Compliant
- Low power HCSL differential output buffers
- Supports Serial-ATA (SATA) at 100 MHz
- No termination resistors required
- 25 MHz Crystal Input or Clock input
- Triangular spread spectrum profile for maximum EMI reduction (Si52112-B6)
- Extended Temperature: -40 to 85 °C
- 3.3 V Power supply
- Small packages:
  - 8-pin TDFN (1.4 x 1.6 mm)
  - 10-pin TDFN (3 x 3 mm)
- Si52112-B5 does not support spread spectrum outputs
- Si52112-B6 supports 0.5% down spread outputs



Patents pending

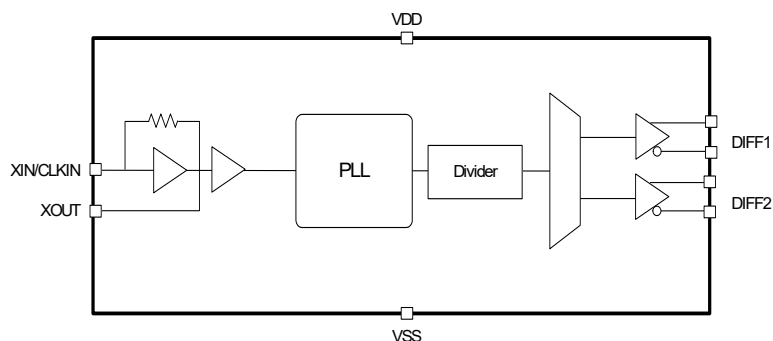
### Applications

- Network attached storage
- Multi-function printer
- PCIe Add-on Cards
- Network Interface Cards
- Docking Stations
- Wireless access point
- Routers
- Digital Still Cameras
- Digital Video Cameras

### Description

Si52112-B5/B6 is a high-performance, PCIe clock generator that can source two PCIe clocks from a 25 MHz crystal or clock input. The clock outputs are compliant to PCIe Gen 1, Gen 2, Gen 3 common clock, and Gen 3 SRNS specifications. The ultra-small footprint (1.4 x 1.6 mm) and industry leading low power consumption make Si52112-B5/B6 the ideal clock solution for applications with tight board space constraints. Measuring PCIe clock jitter is quick and easy with the Silicon Labs PCIe Clock Jitter Tool. Download it for free at [www.silabs.com/pcie-learningcenter](http://www.silabs.com/pcie-learningcenter).

### Functional Block Diagram



---

**TABLE OF CONTENTS**

---

<b><u>Section</u></b>	<b><u>Page</u></b>
<b>1. Electrical Specifications</b> .....	<b>3</b>
<b>2. Crystal Recommendations</b> .....	<b>6</b>
2.1. Crystal Loading .....	6
2.2. Calculating Load Capacitors .....	7
<b>3. Test and Measurement Setup</b> .....	<b>8</b>
<b>4. Pin Descriptions</b> .....	<b>10</b>
4.1. 8-Pin TDFN .....	10
4.2. 10-Pin TDFN .....	11
4.3. 8-Pin TSSOP .....	12
<b>5. Ordering Guide</b> .....	<b>13</b>
<b>6. Package Outlines</b> .....	<b>14</b>
6.1. 8-Pin TDFN Package .....	14
6.2. 10-Pin TDFN Package .....	16
6.3. TSSOP Package .....	18
<b>7. Recommended Design Guideline</b> .....	<b>20</b>
<b>Revision History</b> .....	<b>21</b>
<b>Contact Information</b> .....	<b>22</b>

## 1. Electrical Specifications

**Table 1. DC Electrical Specifications**

Parameter	Symbol	Test Condition	Min	Typ	Max	Unit
Operating Voltage	$V_{DD}$	3.3 V $\pm$ 5%	3.13	3.30	3.46	V
Operating Supply Current	$I_{DD}$	Full Active	—	—	17	mA
Input Pin Capacitance	$C_{IN}$	Input Pin Capacitance	—	3	5	pF
Output Pin Capacitance	$C_{OUT}$	Output Pin Capacitance	—	—	5	pF

**Table 2. AC Electrical Specifications**

Parameter	Symbol	Test Condition	Min	Typ	Max	Unit
<b>Crystal</b>						
Long-term Accuracy	$L_{ACC}$	Measured at $V_{DD}/2$ differential	—	—	250	ppm
<b>Clock Input</b>						
CLKIN Duty Cycle	$T_{DC}$	Measured at $V_{DD}/2$	45	—	55	%
CLKIN Rise and Fall Times	$T_R/T_F$	Measured between 0.2 $V_{DD}$ and 0.8 $V_{DD}$	0.5	—	4.0	V/ns
CLKIN Cycle-to-Cycle Jitter	$T_{CCJ}$	Measured at $V_{DD}/2$	—	—	250	ps
CLKIN Long Term Jitter	$T_{LTJ}$	Measured at $V_{DD}/2$	—	—	350	ps
Input High Voltage	$V_{IH}$	XIN/CLKIN pin	2	—	$V_{DD}+0.3$	V
Input Low Voltage	$V_{IL}$	XIN/CLKIN pin	—	—	0.8	V
Input High Current	$I_{IH}$	XIN/CLKIN pin, $V_{IN} = V_{DD}$	—	—	35	$\mu$ A
Input Low Current	$I_{IL}$	XIN/CLKIN pin, $0 < V_{IN} < 0.8$	-35	—	—	$\mu$ A
<b>HCSL Clocks</b>						
Duty Cycle	$T_{DC}$	Measured at 0 V differential	45	—	55	%
Output-to-Output Skew	$T_{SKEW}$	Measured at 0 V differential	—	—	60	ps
Output Frequency	$F_{OUT}$		—	100	—	MHz
Frequency Accuracy	$F_{ACC}$	All output clocks	—	—	100	ppm
Slew Rate	$T_R/T_F$	Measured differentially from $\pm 150$ mV	0.6	—	4.0	V/ns
Cycle-to-Cycle Jitter	$T_{CCJ}$	Measured at 0 V differential	—	28	70	ps
PCIe Gen 1 Pk-Pk Jitter, Common Clock	$PK-PK_{GEN1}$	PCIe Gen 1	—	24	86	ps
PCIe Gen 2 Phase Jitter, Common Clock	$RMS_{GEN2}$	10 kHz $< F < 1.5$ MHz	—	1.35	3.0	ps
		1.5 MHz $< F < Nyquist$	—	1.4	3.1	ps
PCIe Gen 3 Phase Jitter, Common Clock	$RMS_{GEN3}$	PLL BW of 2–4 or 2–5 MHz, CDR = 10 MHz	—	0.4	0.7	ps
<b>Notes:</b>						
1. Visit <a href="http://www.pcisig.com">www.pcisig.com</a> for complete PCIe specifications.						
2. Download the Silicon Labs PCIe Clock Jitter Tool at <a href="http://www.silabs.com/pcie-learningcenter">www.silabs.com/pcie-learningcenter</a> .						

# Si52112-B5/B6

**Table 2. AC Electrical Specifications (Continued)**

Parameter	Symbol	Test Condition	Min	Typ	Max	Unit
PCIe Gen 3 Phase Jitter, Separate Reference No Spread, SRNS	RMS-GEN3_SRNS	PLL BW of 2–4 or 2–5 MHz, CDR = 10 MHz	—	0.28	0.71	ps
Crossing Point Voltage	V <sub>OX</sub>		300	—	550	mV
Voltage High	V <sub>HIGH</sub>		—	—	1.15	V
Voltage Low	V <sub>LOW</sub>		-0.3	—	—	V
Spread Range	S <sub>RNG</sub>	Down Spread, -B6 only	—	-0.5	—	%
Modulation Frequency	F <sub>MOD</sub>	-B6 only	30	31.5	33	kHz
<b>Enable/Disable and Set-up</b>						
Clock Stabilization from Power-up	T <sub>STABLE</sub>		—	—	3	ms
Stopclock Set-up Time	T <sub>SS</sub>		10.0	—	—	ns
<b>Notes:</b>						
1. Visit <a href="http://www.pcisig.com">www.pcisig.com</a> for complete PCIe specifications.						
2. Download the Silicon Labs PCIe Clock Jitter Tool at <a href="http://www.silabs.com/pcie-learningcenter">www.silabs.com/pcie-learningcenter</a> .						

**Table 3. Thermal Conditions**

Parameter	Symbol	Test Condition	Min	Typ	Max	Unit
Temperature, Storage	T <sub>S</sub>	Non-functional	-65	—	150	°C
Temperature, Operating Ambient	T <sub>A</sub>	Functional	-40	—	85	°C
Temperature, Junction	T <sub>J</sub>	Functional	—	—	125	°C
Dissipation, Junction to Case (8-TDFN)	∅ <sub>JC</sub>	JEDEC (JESD 51) (2-Layers)	—	—	98.8	°C
Dissipation, Junction to Case (10-TDFN)	∅ <sub>JC</sub>	JEDEC (JESD 51) (4-Layers)	—	—	38.3	°C/W
Dissipation, Junction to Case (TSSOP)	∅ <sub>JC</sub>	JEDEC (JESD 51)	—	—	37.0	°C/W
Dissipation, Junction to Ambient (8-TDFN)	∅ <sub>JA</sub>	JEDEC (JESD 51) (2-Layers)	—	—	170.8	°C
Dissipation, Junction to Ambient (10-TDFN)	∅ <sub>JA</sub>	JEDEC (JESD 51) (4-Layers)	—	—	90.4	°C/W
Dissipation, Junction to Ambient (TSSOP)	∅ <sub>JA</sub>	JEDEC (JESD 51)	—	—	124.0	°C/W

Table 4. Absolute Maximum Conditions

Parameter	Symbol	Test Condition	Min	Typ	Max	Unit
Main Supply Voltage	$V_{DD\_3.3V}$		—	—	4.6	V
Input Voltage	$V_{IN}$	Relative to $V_{SS}$	-0.5	—	4.6	$V_{DC}$
ESD Protection (Human Body Model)	$ESD_{HBM}$	JEDEC (JESD 22 - A114)	2000	—	—	V
Flammability Rating	UL-94	UL (Class)	V-0			
<b>Note:</b> While using multiple power supplies, the voltage on any input or I/O pin cannot exceed the power pin during powerup. Power supply sequencing is not required.						

## 2. Crystal Recommendations

If using a crystal input, the device requires a parallel resonance crystal.

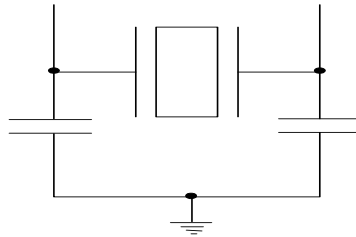
**Table 5. Crystal Recommendations**

Frequency (Fund)	Cut	Loading	Load Cap	ESR	Drive	Shunt Cap (max)	Motional (max)	Tolerance (max)	Stability (max)	Aging (max)
25 MHz	AT	Parallel	12–15 pF	<50 $\Omega$	>150 $\mu$ W	5 pF	0.016 pF	35 ppm	30 ppm	5 ppm

### 2.1. Crystal Loading

Crystal loading is critical in achieving low ppm performance. To realize low ppm performance, use the total capacitance the crystal sees to calculate the appropriate capacitive loading ( $C_L$ ).

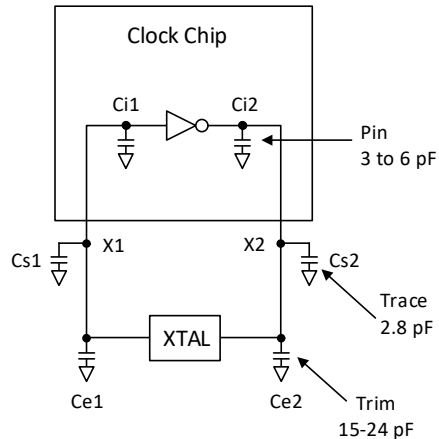
Figure 1 shows a typical crystal configuration using two trim capacitors.



**Figure 1. Crystal Capacitive Clarification**

## 2.2. Calculating Load Capacitors

In addition to the standard external trim capacitors, consider the trace capacitance and pin capacitance to calculate the crystal loading correctly. The total capacitance on both sides is twice the specified crystal load capacitance ( $C_L$ ). Trim capacitors are calculated to provide equal capacitive loading on both sides.



**Figure 2. Crystal Loading Example**

Use the following formulas to calculate the trim capacitor values for Ce1 and Ce2.

### Load Capacitance (each side)

$$C_e = 2 \times C_L - (C_s + C_i)$$

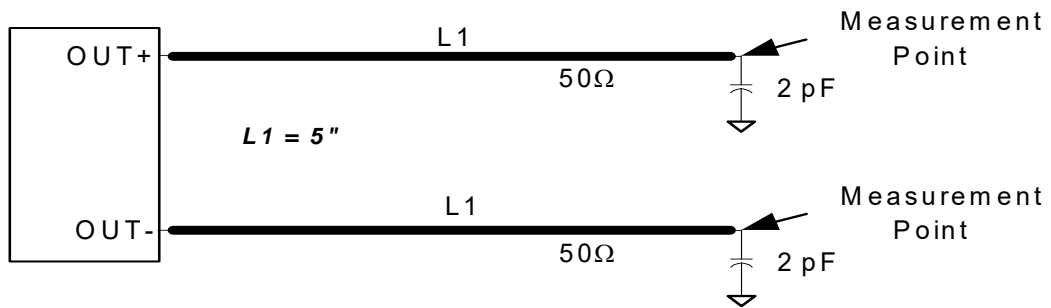
### Total Capacitance (as seen by the crystal)

$$C_{Le} = \frac{1}{\left( \frac{1}{C_{e1} + C_{s1} + C_{i1}} + \frac{1}{C_{e2} + C_{s2} + C_{i2}} \right)}$$

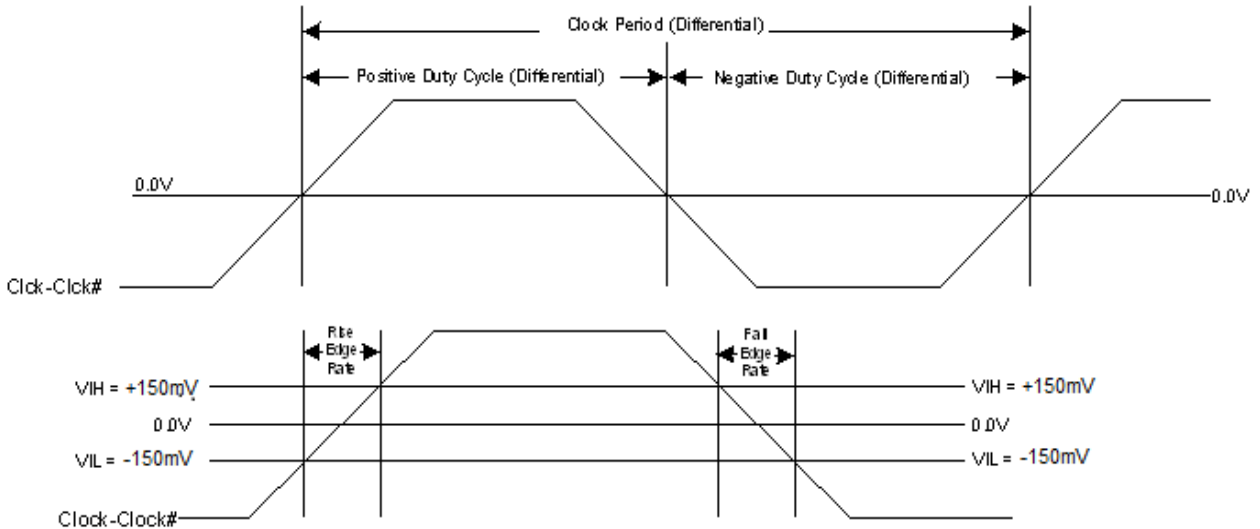
- CL: Crystal load capacitance
- CLe: Actual loading seen by crystal using standard value trim capacitors
- Ce: External trim capacitors
- Cs: Stray capacitance (terraced)
- Ci: Internal capacitance (lead frame, bond wires, etc.)

## 3. Test and Measurement Setup

Figures 3 through 5 show the test load configuration for the differential clock signals.

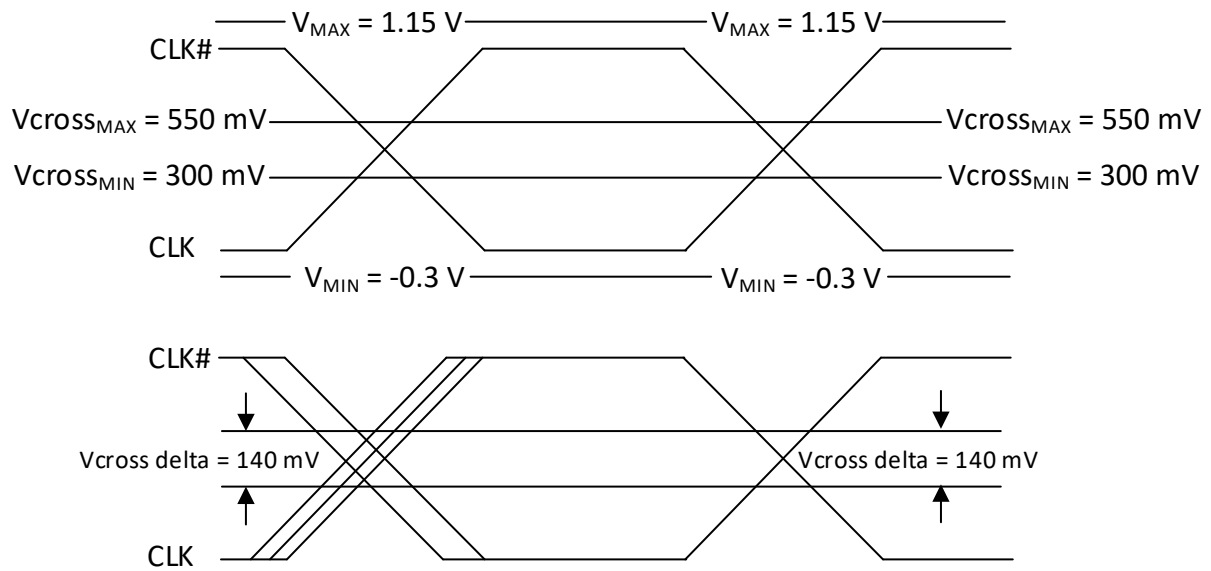


**Figure 3. 0.7 V Differential Load Configuration**



**Figure 4. Differential Measurement for Differential Output Signals (for AC Parameters Measurement)**





**Figure 5. Single-ended Measurement for Differential Output Signals  
(for AC Parameters Measurement)**

# Si52112-B5/B6

## 4. Pin Descriptions

### 4.1. 8-Pin TDFN

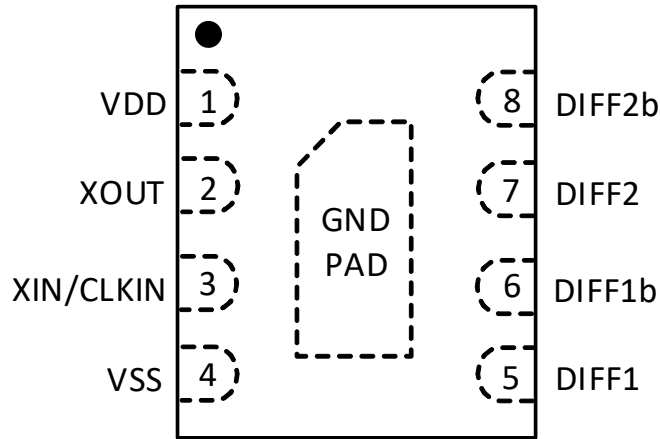


Figure 6. 8-Pin TDFN

Table 6. 8-Pin TDFN Descriptions

Pin #	Name	Type	Description
1	VDD	PWR	3.3 V Power supply.
2	XOUT	O	25.00 MHz crystal output, Float XOUT if using only CLKIN (clock input).
3	XIN/CLKIN	I	25.00 MHz crystal input or 3.3 V, 25 MHz clock Input.
4	VSS	GND	Ground.
5	DIFF1	O, DIF	HCSL DIFF_1, true
6	DIFF1b	O, DIF	HCSL DIFF_1, complementary
7	DIFF2	O, DIF	HCSL DIFF_2, true
8	DIFF2b	O, DIF	HCSL DIFF_2, complementary
	GND PAD	GND	Ground pad. This pad provides an electrical and thermal connection to ground and must be connected for proper operation. Add vias to an internal ground plane as close as possible to the part for optimal thermal dissipation.

## 4.2. 10-Pin TDFN

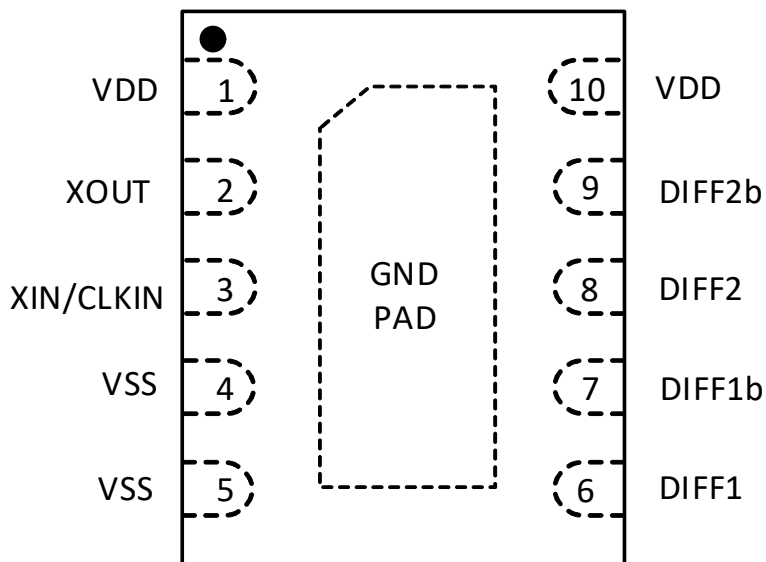


Figure 7. 10-Pin TDFN

Table 7. 10-Pin TDFN Descriptions

Pin #	Name	Type	Description
1	VDD	PWR	3.3 V power supply.
2	XOUT	O	25.00 MHz crystal output, Float XOUT if using only CLKIN (clock input).
3	XIN/CLKIN	I	25.00 MHz crystal input or 3.3 V, 25 MHz clock Input.
4	VSS	GND	Ground.
5	VSS	GND	Ground.
6	DIFF1	O, DIF	HCSL DIFF_1, true
7	DIFF1b	O, DIF	HCSL DIFF_1, complementary
8	DIFF2	O, DIF	HCSL DIFF_2, true
9	DIFF2b	O, DIF	HCSL DIFF_2, complementary
10	VDD	PWR	3.3 V power supply.
	GND PAD	GND	Ground pad. This pad provides an electrical and thermal connection to ground and must be connected for proper operation. Add vias to an internal ground plane as close as possible to the part for optimal thermal dissipation.

# Si52112-B5/B6

## 4.3. 8-Pin TSSOP

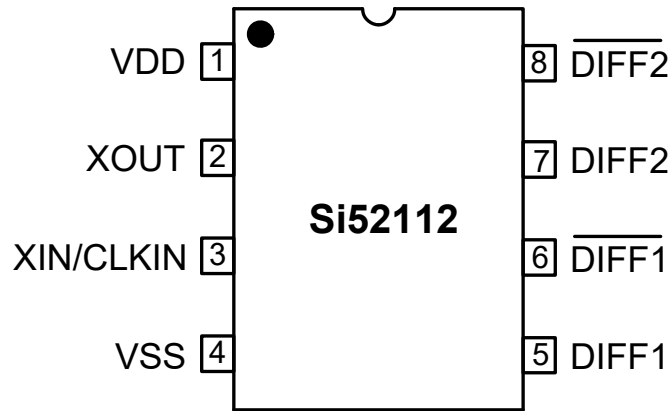


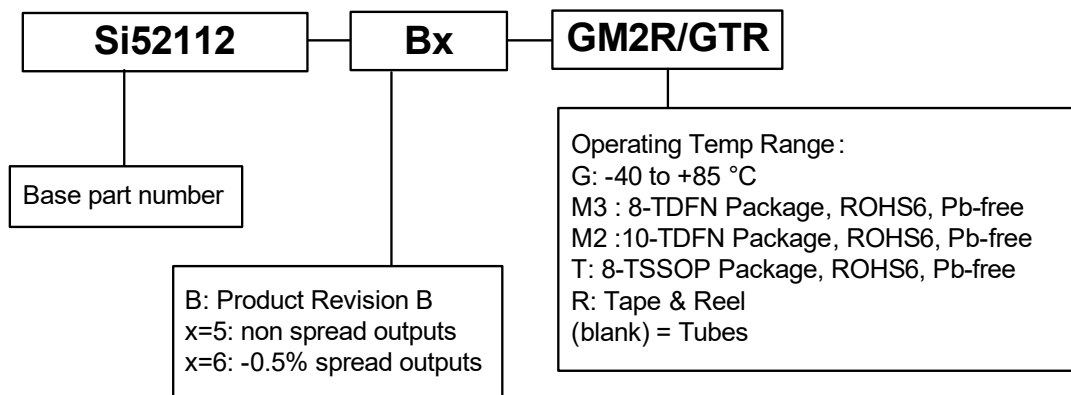
Figure 8. 8-Pin TSSOP

Table 8. 8-Pin TSSOP Descriptions

Pin #	Name	Type	Description
1	VDD	PWR	3.3 V Power supply.
2	XOUT	O	25.00 MHz crystal output, Float XOUT if using only CLKIN (clock input).
3	XIN/CLKIN	I	25.00 MHz crystal input or 3.3 V, 25 MHz clock Input.
4	VSS	GND	Ground.
5	DIFF1	O, DIF	HCSL DIFF_1, true
6	$\overline{\text{DIFF1}}$	O, DIF	HCSL DIFF_1, complementary
7	DIFF2	O, DIF	HCSL DIFF_2, true
8	$\overline{\text{DIFF2}}$	O, DIF	HCSL DIFF_2, complementary

## 5. Ordering Guide

Part Number	Spread Option	Package Type	Temperature
Si52112-B5-GM2	No Spread	10-pin TDFN	Extended, -40 to 85 °C
Si52112-B5-GM2R	No Spread	10-pin TDFN—Tape and Reel	Extended, -40 to 85 °C
Si52112-B5-GM3	No Spread	8-pin TDFN	Extended, -40 to 85 °C
Si52112-B5-GM3R	No Spread	8-pin TDFN—Tape and Reel	Extended, -40 to 85 °C
Si52112-B5-GT	No Spread	8-pin TSSOP	Extended, -40 to 85 °C
Si52112-B5-GTR	No Spread	8-pin TSSOP - Tape and Reel	Extended, -40 to 85 °C
Si52112-B6-GM3	-0.5% Spread	8-pin TDFN	Extended, -40 to 85 °C
Si52112-B6-GM3R	-0.5% Spread	8-pin TDFN—Tape and Reel	Extended, -40 to 85 °C
Si52112-B6-GM2	-0.5% Spread	10-pin TDFN	Extended, -40 to 85 °C
Si52112-B6-GM2R	-0.5% Spread	10-pin TDFN—Tape and Reel	Extended, -40 to 85 °C
Si52112-B6-GT	-0.5% Spread	8-pin TSSOP	Extended, -40 to 85 °C
Si52112-B6-GTR	-0.5% Spread	8-pin TSSOP - Tape and Reel	Extended, -40 to 85 °C



**Figure 9. Ordering Information**

## 6. Package Outlines

### 6.1. 8-Pin TDFN Package

Figure 10 illustrates the package details for the 8-pin TDFN. Table 9 lists the values for the dimensions shown in the illustration.

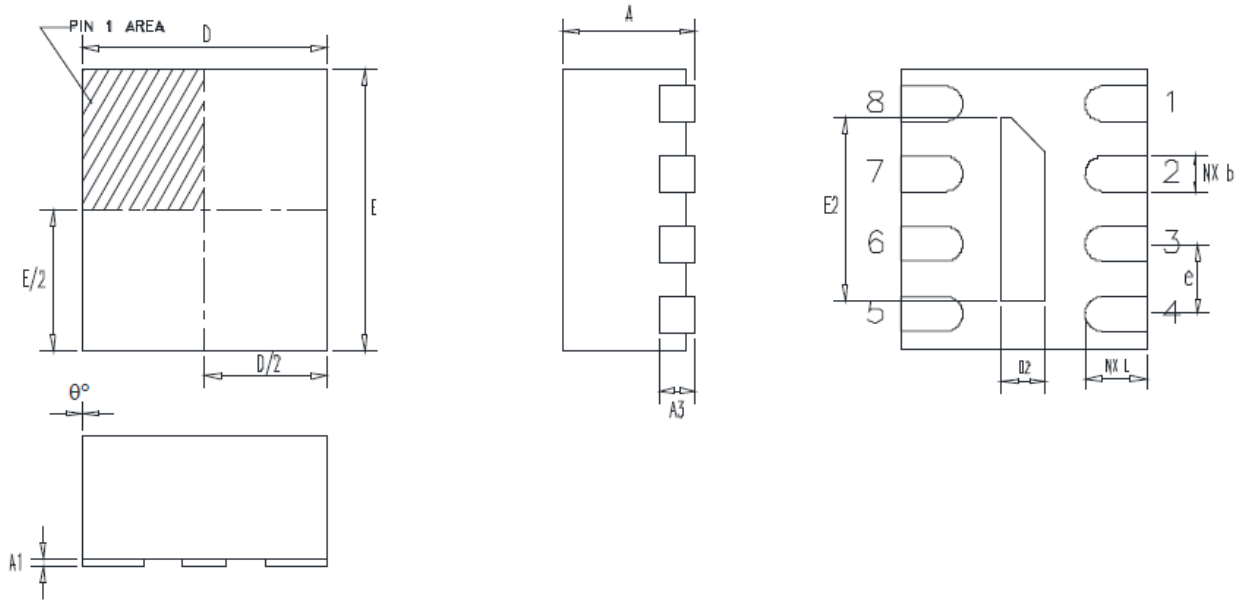


Figure 10. 8-Pin TDFN Package Drawing

Table 9. 8-Pin TDFN Package Diagram Dimensions

Dimension	mm		mils	
	Min	Max	Min	Max
A	0.70	0.80	27.56	31.50
A1	0	0.05	0	1.97
A3	0.175	0.225	6.89	8.86
D	1.3	1.5	51.18	59.06
E	1.5	1.7	59.06	66.93
D2	0.20	0.30	7.87	11.81
E2	1.0	1.1	39.37	43.31
e	0.4 BSC		15.75 BSC	
NX b	0.15	0.25	5.91	9.84
NC L	0.25	0.45	9.84	17.72
0°	0°	4°	0°	4°
ND	0			
NE	4			
<b>Notes:</b>				
<ol style="list-style-type: none"> <li>1. Spade width, lead width and lead thickness exclusive of solder plate.</li> <li>2. Package outline exclusive of mold flashes and burr dimensions.</li> <li>3. Coplanarity applies to the exposed pad as well as the terminals. Coplanarity shall not exceed 0.08 mm.</li> <li>4. Warpage shall not exceed 0.10 mm.</li> <li>5. The Terminal #1 identifier and terminal numbering convention shall conform to JESD 95-1 SPP-012. Details of Terminal #1 identifier are optional, but must be located within the zone indicated. The Terminal #1 identifier may be either a mold or marked feature.</li> <li>6. ND and NE refer to the number of terminals on each D and E side respectively.</li> </ol>				

# Si52112-B5/B6

## 6.2. 10-Pin TDFN Package

Figure 11 illustrates the package details for the 10-pin TDFN. Table 10 lists the values for the dimensions shown in the illustration.

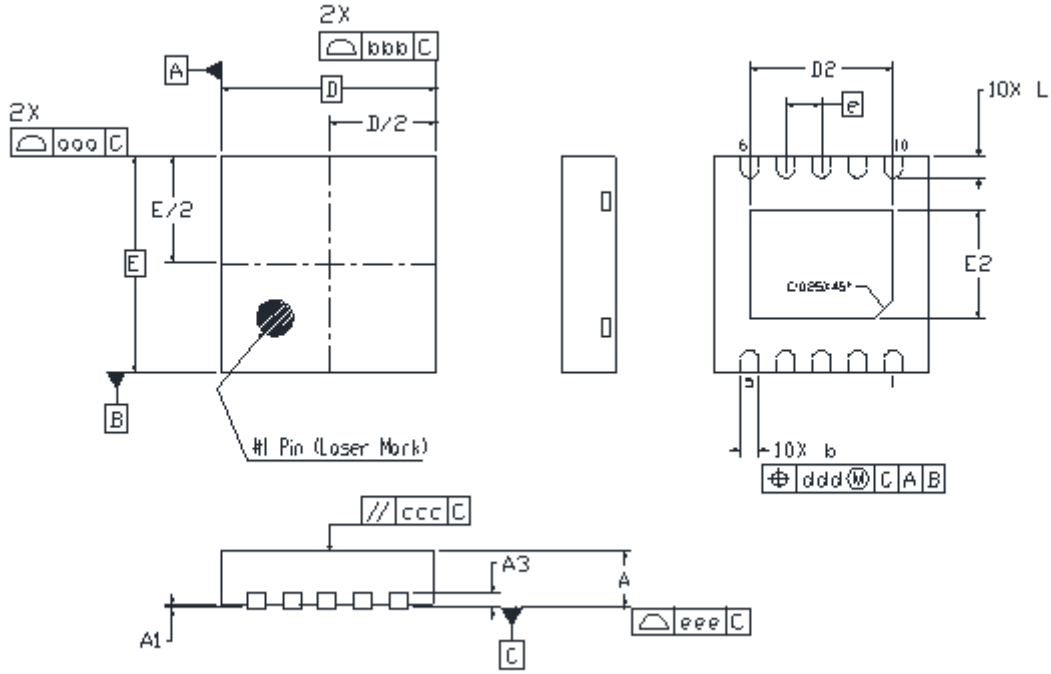


Figure 11. 10-Pin TDFN Package Drawing



Table 10. TDFN Package Diagram Dimensions

Symbol	Min	Nom	Max
A	0.70	0.75	0.80
A1	0.00	0.02	0.05
A3	0.20 REF.		
b	0.18	0.25	0.30
D	3.00 BSC.		
D2	1.90	2.00	2.10
e	0.50 BSC		
E	3.00 BSC		
E2	1.40	1.50	1.60
L	0.25	0.30	0.35
aaa	0.10		
bbb	0.10		
ccc	0.10		
ddd	0.10		
eee	0.08		
<b>Notes:</b>			
1. All dimensions shown are in millimeters (mm) unless otherwise noted.			
2. Dimensioning and Tolerancing per ANSI Y14.5M-1994.			
3. Recommended card reflow profile is per the JEDEC/IPC J-STD-020 specification for Small Body Components.			
4. This drawing conforms to the JEDEC Solid State Outline MO-229.			

# Si52112-B5/B6

## 6.3. TSSOP Package

Figure 12 illustrates the package details for the 8-pin TSSOP. Table 11 lists the values for the dimensions shown in the illustration.

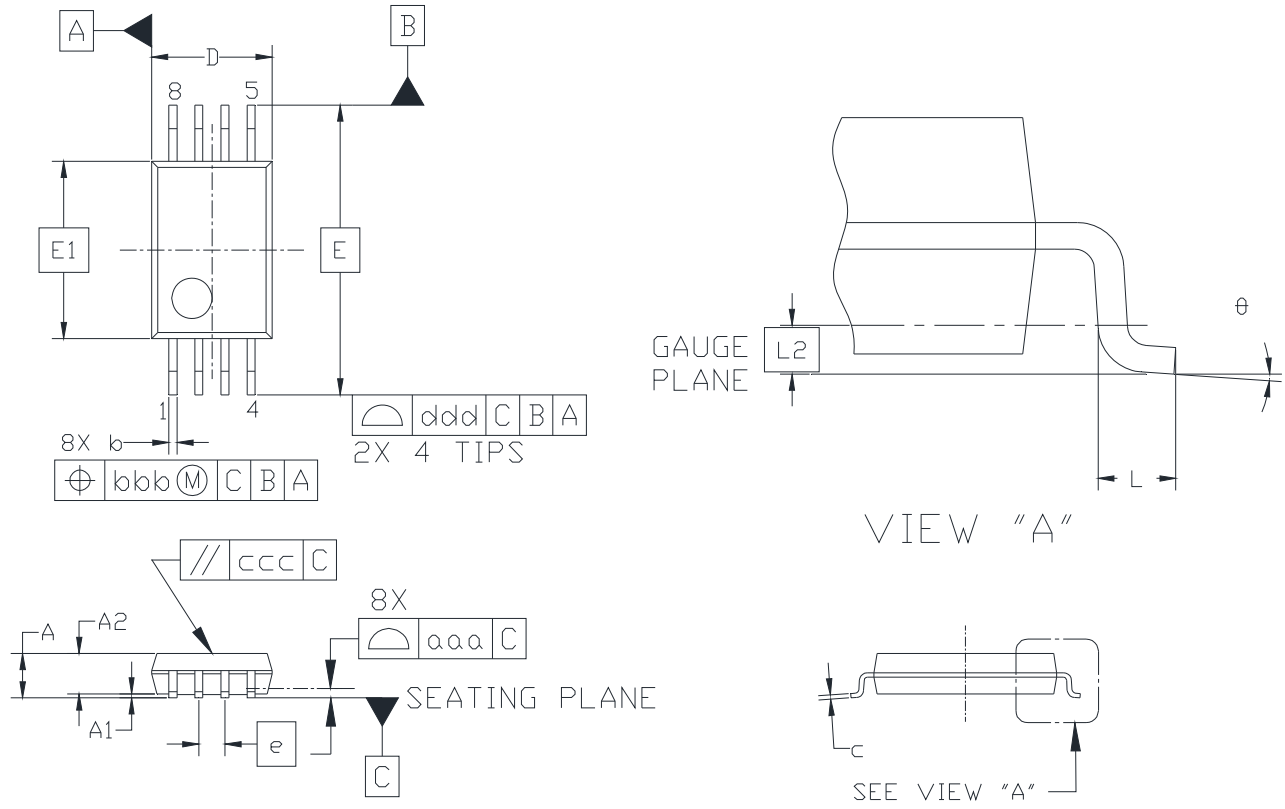


Figure 12. 8-Pin TSSOP Package Drawing

Table 11. TSSOP Package Diagram Dimensions

Symbol	Min	Nom	Max
A	—	—	1.20
A1	0.05	—	0.15
A2	0.80	0.90	1.05
b	0.19	—	0.30
c	0.09	—	0.20
D	2.90	3.00	3.10
E	6.40 BSC		
E1	4.30	4.40	4.50
e	0.65 BSC		
L	0.45	0.60	0.75
L2	0.25 BSC		
$\theta$	0°	—	8°
aaa	0.10		
bbb	0.10		
ccc	0.05		
ddd	0.20		
<b>Notes:</b>			
<ol style="list-style-type: none"> <li>1. All dimensions shown are in millimeters (mm) unless otherwise noted.</li> <li>2. Dimensioning and Tolerancing per ANSI Y14.5M-1994.</li> <li>3. This drawing conforms to the JEDEC Solid State Outline MO-153, Variation AA.</li> <li>4. Recommended card reflow profile is per the JEDEC/IPC J-STD-020C specification for Small Body Components.</li> </ol>			

## 7. Recommended Design Guideline

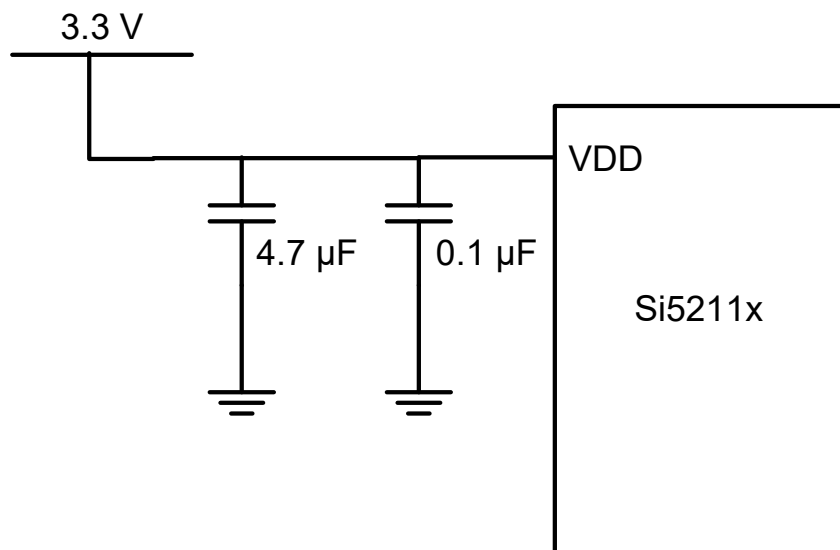


Figure 13. Recommended Power Supply Filtering

## REVISION HISTORY

### Revision 1.3

March, 2020

- Added 8-pin TDFN in " Features" on page 1.
- Updated " Applications" on page 1.
- Updated Table 1, "Recommended Operating Conditions," on page 3.
  - Removed commercial supply voltage spec.
- Updated Table 1, "DC Electrical Specifications," on page 3.
  - Updated operating voltage spec test condition.
- Updated Table 2, "AC Electrical Specifications," on page 3.
  - Updated PCIe Gen 3 Phase Jitter, Common Clock max from 1ps to 0.7 ps.
- Added "4.1. 8-Pin TDFN" on page 10.
- Updated "4.2. 10-Pin TDFN" on page 11.
  - Added GND PAD to Pin Descriptions.
- Updated "5. Ordering Guide" on page 13.
  - Added orderable part numbers for 8-Pin TDFN.
- Updated "6.1. 8-Pin TDFN Package" on page 14.

### Revision 1.2

November, 2014

- Updated Features on page 1.
- Updated Description on page 1.
- Updated Table 2, "AC Electrical Specifications," on page 3.

### Revision 1.1

July, 2014

- Added "4.3. 8-Pin TSSOP" pin description on page 12.

### Revision 1.0

April, 2013

- Initial release.



## ClockBuilder Pro

One-click access to Timing tools, documentation, software, source code libraries & more. Available for Windows and iOS (CBGo only).

[www.silabs.com/CBPro](http://www.silabs.com/CBPro)



**Timing Portfolio**  
[www.silabs.com/timing](http://www.silabs.com/timing)



**SW/HW**  
[www.silabs.com/CBPro](http://www.silabs.com/CBPro)



**Quality**  
[www.silabs.com/quality](http://www.silabs.com/quality)



**Support and Community**  
[community.silabs.com](http://community.silabs.com)

### Disclaimer

Silicon Labs intends to provide customers with the latest, accurate, and in-depth documentation of all peripherals and modules available for system and software implementers using or intending to use the Silicon Labs products. Characterization data, available modules and peripherals, memory sizes and memory addresses refer to each specific device, and "Typical" parameters provided can and do vary in different applications. Application examples described herein are for illustrative purposes only. Silicon Labs reserves the right to make changes without further notice to the product information, specifications, and descriptions herein, and does not give warranties as to the accuracy or completeness of the included information. Without prior notification, Silicon Labs may update product firmware during the manufacturing process for security or reliability reasons. Such changes will not alter the specifications or the performance of the product. Silicon Labs shall have no liability for the consequences of use of the information supplied in this document. This document does not imply or expressly grant any license to design or fabricate any integrated circuits. The products are not designed or authorized to be used within any FDA Class III devices, applications for which FDA premarket approval is required, or Life Support Systems without the specific written consent of Silicon Labs. A "Life Support System" is any product or system intended to support or sustain life and/or health, which, if it fails, can be reasonably expected to result in significant personal injury or death. Silicon Labs products are not designed or authorized for military applications. Silicon Labs products shall under no circumstances be used in weapons of mass destruction including (but not limited to) nuclear, biological or chemical weapons, or missiles capable of delivering such weapons. Silicon Labs disclaims all express and implied warranties and shall not be responsible or liable for any injuries or damages related to use of a Silicon Labs product in such unauthorized applications.

### Trademark Information

Silicon Laboratories Inc.®, Silicon Laboratories®, Silicon Labs®, SiLabs® and the Silicon Labs logo®, Bluegiga®, Bluegiga Logo®, ClockBuilder®, CMEMS®, DSPLL®, EFM®, EFM32®, EFR, Ember®, Energy Micro, Energy Micro logo and combinations thereof, "the world's most energy friendly microcontrollers", Ember®, EZLink®, EZRadio®, EZRadioPRO®, Gecko®, Gecko OS, Gecko OS Studio, ISOModem®, Precision32®, ProSLIC®, Simplicity Studio®, SiPHY®, Telegesis, the Telegesis Logo®, USBXpress®, Zentri, the Zentri logo and Zentri DMS, Z-Wave®, and others are trademarks or registered trademarks of Silicon Labs. ARM, CORTEX, Cortex-M3 and THUMB are trademarks or registered trademarks of ARM Holdings. Kell is a registered trademark of ARM Limited. Wi-Fi is a registered trademark of the Wi-Fi Alliance. All other products or brand names mentioned herein are trademarks of their respective holders.



Silicon Laboratories Inc.  
400 West Cesar Chavez  
Austin, TX 78701  
USA

<http://www.silabs.com>

Компания «Океан Электроники» предлагает заключение долгосрочных отношений при поставках импортных электронных компонентов на взаимовыгодных условиях!

Наши преимущества:

- Поставка оригинальных импортных электронных компонентов напрямую с производств Америки, Европы и Азии, а так же с крупнейших складов мира;
- Широкая линейка поставок активных и пассивных импортных электронных компонентов (более 30 млн. наименований);
- Поставка сложных, дефицитных, либо снятых с производства позиций;
- Оперативные сроки поставки под заказ (от 5 рабочих дней);
- Экспресс доставка в любую точку России;
- Помощь Конструкторского Отдела и консультации квалифицированных инженеров;
- Техническая поддержка проекта, помощь в подборе аналогов, поставка прототипов;
- Поставка электронных компонентов под контролем ВП;
- Система менеджмента качества сертифицирована по Международному стандарту ISO 9001;
- При необходимости вся продукция военного и аэрокосмического назначения проходит испытания и сертификацию в лаборатории (по согласованию с заказчиком);
- Поставка специализированных компонентов военного и аэрокосмического уровня качества (Xilinx, Altera, Analog Devices, Intersil, Interpoint, Microsemi, Actel, Aeroflex, Peregrine, VPT, Syfer, Eurofarad, Texas Instruments, MS Kennedy, Miteq, Cobham, E2V, MA-COM, Hittite, Mini-Circuits, General Dynamics и др.);

Компания «Океан Электроники» является официальным дистрибьютором и эксклюзивным представителем в России одного из крупнейших производителей разъемов военного и аэрокосмического назначения «JONHON», а так же официальным дистрибьютором и эксклюзивным представителем в России производителя высокотехнологичных и надежных решений для передачи СВЧ сигналов «FORSTAR».



## JONHON

«JONHON» (основан в 1970 г.)

Разъемы специального, военного и аэрокосмического назначения:

(Применяются в военной, авиационной, аэрокосмической, морской, железнодорожной, горно- и нефтедобывающей отраслях промышленности)

«FORSTAR» (основан в 1998 г.)

ВЧ соединители, коаксиальные кабели, кабельные сборки и микроволновые компоненты:

(Применяются в телекоммуникациях гражданского и специального назначения, в средствах связи, РЛС, а так же военной, авиационной и аэрокосмической отраслях промышленности).



Телефон: 8 (812) 309-75-97 (многоканальный)

Факс: 8 (812) 320-03-32

Электронная почта: [ocean@oceanchips.ru](mailto:ocean@oceanchips.ru)

Web: <http://oceanchips.ru/>

Адрес: 198099, г. Санкт-Петербург, ул. Калинина, д. 2, корп. 4, лит. А