

SoC Ultra-Low Power RF-Microcontroller for RF Carrier Frequencies in the Range 27 - 1050 MHz



ON Semiconductor®

www.onsemi.com

AXM0F243

OVERVIEW

Features

System-on-Chip (SoC) Ultra-low Power Advanced Narrow-band RF-microcontroller for Wireless Communication Applications

- QFN40 Package
- Supply Range 1.8 V – 3.6 V
- –40°C to 85°C
- Deep Sleep Mode with Operational Analog and 2.5 μ A Digital System Current
- Radio RX-mode
 - 6.5 mA @ 169 MHz
 - 9.5 mA @ 868 MHz and 433 MHz
- Radio TX-mode at 868 MHz
 - 7.6 mA @ 0 dBm
 - 21 mA @ 10 dBm
 - 55 mA @ 15 dBm
- This is a Pb-Free Device

32-bit MCU Subsystem

- 48-MHz ARM Cortex-M0+ CPU
- Up to 64 KB of Flash with Read Accelerator
- Up to 8 KB of SRAM

Programmable Analog

- Two opamps with reconfigurable high-drive external and high-bandwidth internal drive and Comparator modes and ADC input buffering capability. Opamps can operate in Deep Sleep low-power mode.
- 12-bit 1-Msps SAR ADC with differential and single-ended modes
- Single-slope 10-bit ADC function
- Two current DACs (IDACs) for general-purpose applications on any pin
- One low-power comparator that operates in Deep Sleep low-power mode

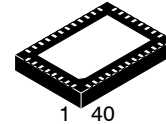

QFN40 7x5, 0.5P
CASE 485EG

ORDERING INFORMATION

See detailed ordering and shipping information in Table 59 of this data sheet.

Programmable Digital

- Programmable logic blocks allowing Boolean operations to be performed on port inputs and outputs

Low-Power 1.8 V to 3.6 V Operation

- Deep Sleep mode with operational analog and 2.5 μ A digital system current

Serial Communication

- Two independent run-time reconfigurable Serial Communication Blocks (SCBs) with re-configurable I²C, SPI, or UART functionality

Timing and Pulse-Width Modulation

- Five 16-bit timer/counter/pulse-width modulator (TCPWM) blocks, of which three PWMs can be connected to GPIO Pins
- Center-aligned, Edge, and Pseudo-random modes
- Comparator-based triggering of Kill signals for motor drive and other high-reliability digital logic applications

Up to 19 Programmable GPIO Pins

- Any GPIO pin can be analog, or digital
- Drive modes, strengths, and slew rates are programmable

AXM0F243

High Performance Narrow-band RF Transceiver compatible to AX5043 (FSK/MSK/4-FSK/GFSK/GMSK/ASK/AFSK/FM/PSK)

- Receiver
 - ◆ Carrier Frequencies from 27 to 1050 MHz
 - ◆ Data Rates from 0.1 kbps to 125 kbps
 - ◆ Optional Forward Error Correction (FEC)
 - ◆ Sensitivity without FEC
 - 135 dBm @ 0.1 kbps, 868 MHz, FSK
 - 126 dBm @ 1 kbps, 868 MHz, FSK
 - 117 dBm @ 10 kbps, 868 MHz, FSK
 - 107 dBm @ 100 kbps, 868 MHz, FSK
 - 105 dBm @ 125 kbps, 868 MHz, FSK
 - ◆ Sensitivity with FEC
 - 138 dBm @ 0.1 kbps, 868 MHz, PSK
 - 130 dBm @ 1 kbps, 868 MHz, PSK
 - 120 dBm @ 10 kbps, 868 MHz, PSK
 - 109 dBm @ 100 kbps, 868 MHz, PSK
 - 108 dBm @ 125 kbps, 868 MHz, PSK
 - ◆ Sensitivity with FEC
 - 137 dBm @ 0.1 kbps, 868 MHz, FSK
 - 122 dBm @ 5 kbps, 868 MHz, FSK
 - 111 dBm @ 50 kbps, 868 MHz, FSK
 - ◆ High Selectivity Receiver with up to 47 dB Adjacent Channel Rejection
 - ◆ 0 dBm Maximum Input Power
 - ◆ ±10% Data-rate Error Tolerance
 - ◆ Support for Antenna Diversity with External Antenna Switch
 - ◆ Short Preamble Modes allow the Receiver to work with as little as 16 Preamble Bits
 - ◆ Fast State Switching Times
 - 200 μs TX → RX Switching Time
 - 62 μs RX → TX Switching Time
- Transmitter
 - ◆ Carrier Frequencies from 27 to 1050 MHz
 - ◆ Data-rates from 0.1 kbps to 125 kbps
 - ◆ High Efficiency, High Linearity Integrated Power Amplifier
 - ◆ Maximum Output Power
 - 16 dBm @ 868 MHz
 - 16 dBm @ 433 MHz
 - 16 dBm @ 169 MHz
 - ◆ Power Level programmable in 0.5 dB Steps
 - ◆ GFSK Shaping with BT=0.3 or BT=0.5
 - ◆ Unrestricted Power Ramp Shaping
- RF Frequency Generation
 - ◆ Configurable for Usage in 27 MHz –1050 MHz Bands
 - ◆ RF Carrier Frequency and FSK Deviation Programmable in 1 Hz Steps
- ◆ Ultra Fast Settling RF Frequency Synthesizer for Low-power Consumption
- ◆ Fully Integrated RF Frequency Synthesizer with VCO Auto-ranging and Band-width Boost Modes for Fast Locking
- ◆ Configurable for either Fully Integrated VCO, Internal VCO with External Inductor or Fully External VCO
- ◆ Configurable for either Fully Integrated or External Synthesizer Loop Filter for a Large Range of Bandwidths
- ◆ Channel Hopping up to 2000 hops/s
- ◆ Automatic Frequency Control (AFC)
- Flexible Antenna Interface
 - ◆ Integrated RX/TX Switching with Differential Antenna Pins
 - ◆ Mode with Differential RX Pins and Single-ended TX Pin for Usage with External PAs and for Maximum PA Efficiency at Low Output Power
- Wakeup-on-Radio
 - ◆ 640 Hz or 10 kHz Lowest Power Wake-up Timer
 - ◆ Wake-up Time Interval programmable between 98 μs and 102 s
- Sophisticated Radio Controller
 - ◆ Antenna Diversity and RX/TX Switch Control
 - ◆ Fully Automatic Packet Reception and Transmission without Micro-controller Intervention
 - ◆ Supports HDLC, Raw, Wireless M-Bus Frames and Arbitrary Defined Frames
 - ◆ Automatic Channel Noise Level Tracking
 - ◆ μs Resolution Timestamps for Exact Timing (eg. for Frequency Hopping Systems)
 - ◆ 256 Byte Micro-programmable FIFO, optionally supports Packet Sizes > 256 Bytes
 - ◆ Three Matching Units for Preamble Byte, Sync-word and Address
 - ◆ Ability to store RSSI, Frequency Offset and Data-rate Offset with the Packet Data
 - ◆ Multiple Receiver Parameter Sets allow the use of more aggressive Receiver Parameters during Preamble, dramatically shortening the Required Preamble Length at no Sensitivity Degradation
- Advanced Crystal Oscillator (RF Reference Oscillator)
 - ◆ Fast Start-up and Lowest Power Steady-state XTAL Oscillator for a Wide Range of Crystals
 - ◆ Integrated Tuning Capacitors
 - ◆ Possibility of Applying an External Clock Reference (TCXO)

AXM0F243

Applications

27 – 1050 MHz Licensed and Unlicensed Radio Systems

- Internet of Things
- Automatic meter reading (AMR)
- Security applications
- Building automation
- Wireless networks
- Messaging Paging
- Compatible with: Wireless M-Bus, POCSAG, FLEX, KNX, Sigfox, Z-Wave, enocean
- Regulatory Regimes: EN 300 220 V2.3.1 including the Narrow-band 12.5 kHz, 20 kHz and 25 kHz Definitions; EN 300 422; FCC Part 15.247; FCC Part 15.249; FCC Part 90 6.25 kHz, 12.5 kHz and 25 kHz

AXM0F243

BLOCK DIAGRAM

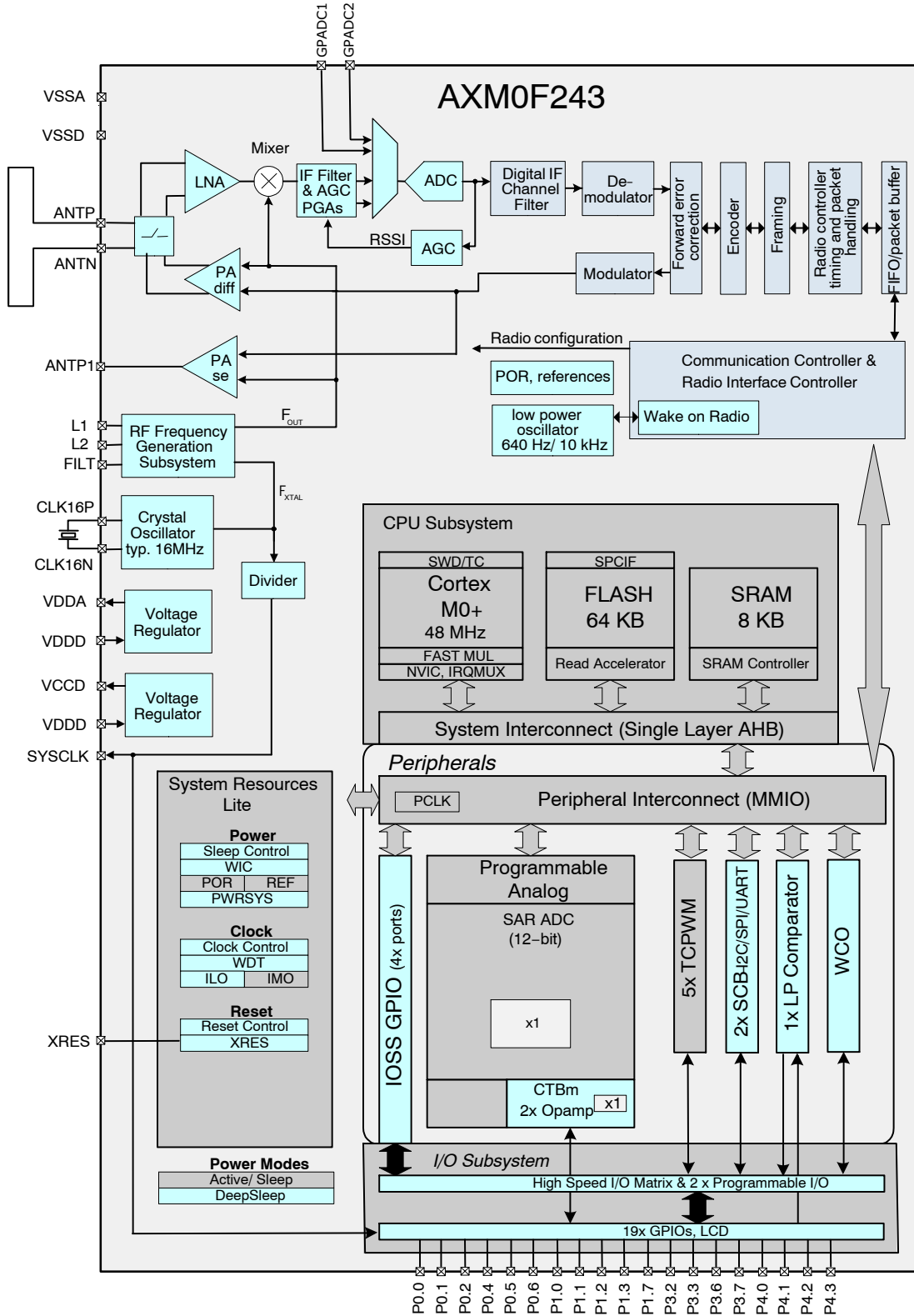

Figure 1. Functional Block Diagram of the AXM0F243

AXM0F243

Table 1. PIN FUNCTION DESCRIPTION

| Symbol | Pin(s) | Type | Description |
|--------|------------|-------------|---|
| VDDA | 1 | P | Analog power output, decouple to neighboring VSSA |
| VSSA | 2 | P | Ground, decouple to neighboring VDDA |
| ANTP | 3 | A | Differential antenna input/output |
| ANTN | 4 | A | Differential antenna input/output |
| ANTP1 | 5 | A | Single-ended antenna output |
| VSSA | 6 | P | Ground, decouple to neighboring VDDA |
| VDDA | 7 | P | Analog power output, decouple to neighboring VSSA |
| VSSA | 8 | P | Ground |
| FILT | 9 | A | Optional synthesizer filter |
| L2 | 10 | A | Optional synthesizer inductor |
| L1 | 11 | A | Optional synthesizer inductor |
| VSSD | 12 | P | Ground |
| SYSCLK | 13 | I/O/PU | Default functionality: system clock output |
| P3.2 | 14 | I/O/PU/PD/A | General purpose IO |
| P3.3 | 15 | I/O/PU/PD/A | General purpose IO |
| P3.6 | 16 | I/O/PU/PD/A | General purpose IO |
| P3.7 | 17 | I/O/PU/PD/A | General purpose IO |
| P4.0 | 18 | I/O/PU/PD/A | General purpose IO |
| P4.1 | 19 | I/O/PU/PD/A | General purpose IO |
| P4.2 | 20 | I/O/PU/PD/A | General purpose IO |
| P4.3 | 21 | I/O/PU/PD/A | General purpose IO |
| P0.0 | 22 | I/O/PU/PD/A | General purpose IO |
| P0.1 | 23 | I/O/PU/PD/A | General purpose IO |
| P0.2 | 24 | I/O/PU/PD/A | General purpose IO |
| P0.4 | 25 | I/O/PU/PD/A | General purpose IO |
| P0.5 | 26 | I/O/PU/PD/A | General purpose IO |
| P0.6 | 27 | I/O/PU/PD/A | General purpose IO |
| XRES | 28 | I/PU | Reset pin |
| VCCD | 29 | P | Regulated digital supply, decouple to ground |
| VDDD | 30 | P | Unregulated power supply |
| P1.0 | 31 | I/O/PU/PD/A | General purpose IO |
| P1.1 | 32 | I/O/PU/PD/A | General purpose IO |
| P1.2 | 33 | I/O/PU/PD/A | General purpose IO |
| P1.3 | 34 | I/O/PU/PD/A | General purpose IO |
| P1.7 | 35 | I/O/PU/PD/A | General purpose IO |
| VDDD | 36 | P | Unregulated power supply |
| GPADC1 | 37 | A | GPADC input, must be connected to GND if not used |
| GPADC2 | 38 | A | GPADC input, must be connected to GND if not used |
| CLK16N | 39 | A | Crystal oscillator input/output (RF reference oscillator) |
| CLK16P | 40 | A | Crystal oscillator input/output (RF reference oscillator) |
| GND | Center pad | P | Ground on center pad of QFN, must be connected |

A = analog input
 I = digital input signal
 O = digital output signal
 PU = pull-up

N = not to be connected
 P = power or ground
 PD = pull-down

AXM0F243

Alternate Pin Functions

Each Port pin has can be assigned to one of multiple peripheral function. The pin assignments are shown in the following table.

Table 2. ALTERNATE PIN FUNCTIONS

| Pin | HSIOM_PORT_SEL[x].SELY (*5) | | | | | |
|------|-----------------------------|-------------------|--------------------------|------------------|------------------|----------------------|
| | Active | | | | DeepSleep | |
| | ACTIVE #0 | ACTIVE #1 | ACTIVE #2 | ACTIVE #3 | Deep Sleep #2 | Deep Sleep #3 |
| P0.0 | | scb[2].uart_cts:0 | dsi_sar_data_vali d:0 | tcpwm.tr_in[0] | scb[2].i2c_scl:0 | scb[0].spi_select1:0 |
| P0.1 | | scb[2].uart_rts:0 | tr_sar_out | tcpwm.tr_in[1] | scb[2].i2c_sda:0 | scb[0].spi_select2:0 |
| P0.2 | | | dsi_sar_sample_d one | | | scb[0].spi_select3:0 |
| P0.4 | | | dsi_sar_data[0]:0 | scb[2].uart_rx:0 | | |
| P0.5 | | | dsi_sar_data[1]:0 | scb[2].uart_tx:0 | | |
| P0.6 | srss.ext_clk | | | scb[2].uart_tx:1 | | |
| P1.0 | tcpwm.line[2]:1 | scb[0].uart_rx:1 | | | scb[0].i2c_scl:0 | scb[0].spi_mosi:1 |
| P1.1 | tcpwm.line_compl [2]:1 | scb[0].uart_tx:1 | | | scb[0].i2c_sda:0 | scb[0].spi_miso:1 |
| P1.2 | tcpwm.line[3]:1 | scb[0].uart_cts:1 | dsi_sar_data[3]:0 | tcpwm.tr_in[2] | scb[2].i2c_scl:1 | scb[0].spi_clk:1 |
| P1.3 | tcpwm.line_compl [3]:1 | scb[0].uart_rts:1 | dsi_sar_data[4]:0 | tcpwm.tr_in[3] | scb[2].i2c_sda:1 | scb[0].spi_select0:1 |
| P1.7 | | | | | | scb[2].spi_clk |
| P3.2 | tcpwm.line[1]:0 | | | | cpuss.swd_data | |
| P3.3 | tcpwm.line_compl [1]:0 | | | | cpuss.swd_clk | |
| P3.6 | tcpwm.line[3]:0 | | dsi_ctb_cmp0 | | | |
| P3.7 | tcpwm.line_compl [3]:0 | | dsi_ctb_cmp1 | | | scb[2].spi_miso |
| P4.0 | | scb[0].uart_rx:0 | dsi_sar_data[9]:0 | | scb[0].i2c_scl:1 | scb[0].spi_mosi:0 |
| P4.1 | | scb[0].uart_tx:0 | | | scb[0].i2c_sda:1 | scb[0].spi_miso:0 |
| P4.2 | | scb[0].uart_cts:0 | dsi_sar_data[10]:0 | | lpcomp.comp[0]:0 | scb[0].spi_clk:0 |
| P4.3 | | scb[0].uart_rts:0 | dsi_sar_data[11]:0 | | | scb[0].spi_select0:0 |

AXM0F243

Table 3. ANALOG PIN FUNCTION

| Pin | Analog |
|------|----------------------------------|
| P0.0 | lpcomp[0].vplus |
| P0.1 | lpcomp[0].vminus |
| P0.2 | |
| P0.4 | wco[0].wco_in |
| P0.5 | wco[0].wco_out |
| P0.6 | srss[0].adft_por_pad_hv |
| P1.0 | ctb0_oa[0].vplus |
| P1.1 | ctb0_oa[0].vminus |
| P1.2 | ctb0_oa[0].vout10x |
| P1.3 | ctb0_oa[1].vout10x |
| P1.5 | ctb0_oa[1].vplus |
| P1.7 | ctb0_oa[1].vplus sar_ext_vref |
| P3.2 | |
| P3.3 | |
| P3.6 | ctb0_oa[0].dsi_comp |
| P3.7 | ctb0_oa[1].dsi_comp |
| P4.0 | |
| P4.1 | |
| P4.2 | |
| P4.3 | |

PINOUT DRAWING

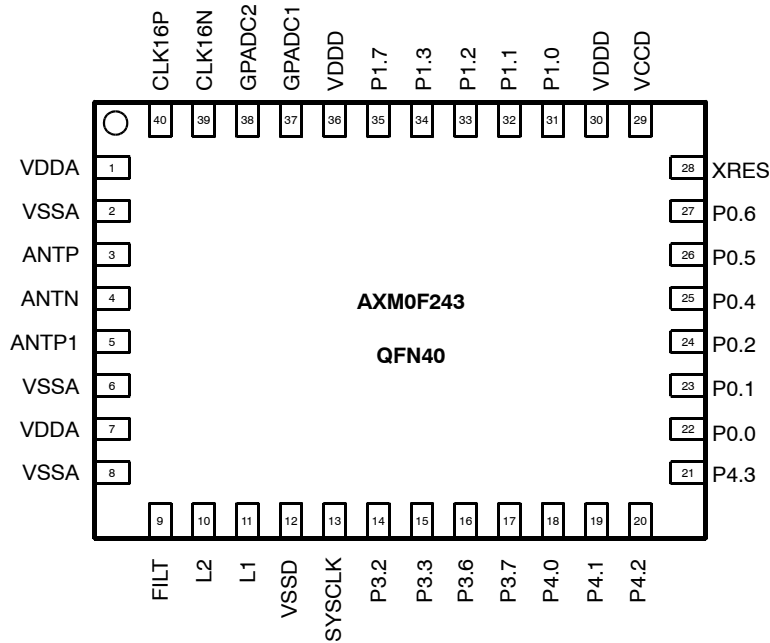

Figure 2. Pinout Drawing (Top View)

SPECIFICATIONS

Table 4. ABSOLUTE MAXIMUM RATINGS (Note 1)

| Symbol | Description | Condition | Min | Max | Units |
|------------------|--|-------------------------------|-------|------------|-------|
| VDDD | Supply voltage | | -0.5 | 5.5 | V |
| IDD | Supply current | | | 200 | mA |
| P _{tot} | Total power consumption | | | 800 | mW |
| P _i | Absolute maximum input power at receiver input | ANTP and ANTN pins in RX mode | | 10 | dBm |
| I _{I1} | DC current into pin SYSCLK | | -10 | 10 | mA |
| I _{I2} | DC current into GPIO | | -25 | 25 | mA |
| I _{I3} | DC current into pins ANTP, ANTN, ANTP1 | | -100 | 100 | mA |
| V _{ia} | Input voltage ANTP, ANTN, ANTP1 pins | | -0.5 | 5.5 | V |
| | Input voltage GPIO pins | | -0.5 | VDDD + 0.5 | V |
| V _{es} | Electrostatic handling | HBM | -2000 | 2000 | V |
| Lu | GPIO pin current for latch-up | | -140 | 140 | mA |
| T _{amb} | Operating temperature | | -40 | 85 | °C |
| T _{stg} | Storage temperature | | -65 | 150 | °C |
| T _j | Junction Temperature | | | 150 | °C |

Stresses exceeding those listed in the Maximum Ratings table may damage the device. If any of these limits are exceeded, device functionality should not be assumed, damage may occur and reliability may be affected.

1. Exposure to absolute maximum rating conditions for extended periods may affect device reliability.

DC Characteristics

Table 5. SUPPLIES

| Sym | Description | Condition | Min | Typ | Max | Units |
|---------------------------|---|--|-----|-----|-----|-------|
| T _{AMB} | Operational ambient temperature | | -40 | 27 | 85 | °C |
| VDDD | I/O and voltage regulator supply voltage | | 1.8 | 3.0 | 3.6 | V |
| IDD _{sleep1} | Sleep mode I ² C wakeup, WDT and Comparators on | 6 MHz. Max is at 85°C and 3.6 V | | 1.7 | | mA |
| IDD _{sleep2} | Sleep mode I ² C wakeup, WDT and Comparators on | 12 MHz. Max is at 85°C and 3.6 V | | 2.2 | | mA |
| IDD _{deep-sleep} | Deep Sleep current I ² C wakeup and WDT on | Max is at 85°C and 3.6 V | | 2.5 | | µA |
| IDD ₆ | CPU at 6 MHz, execute from flash | Max is at 85°C and 3.6 V | | 1.8 | | mA |
| IDD ₂₄ | CPU at 24 MHz, execute from flash | Max is at 85°C and 3.6 V | | 3.0 | | mA |
| IDD ₄₈ | CPU at 48 MHz, execute from flash | Max is at 85°C and 3.6 V | | 5.4 | | mA |
| IDD _{xres} | Supply current while XRES asserted | | | 2 | | mA |
| I _{RX} | Current consumption RX RF frequency generation subsystem: Internal VCO and internal loop-filter | 868 MHz, datarate 6 kbps | | 9.5 | | mA |
| | | 169 MHz, datarate 6 kbps | | 6.5 | | |
| | | 868 MHz, datarate 100 kbps | | 11 | | |
| | | 169 MHz, datarate 100 kbps | | 7.5 | | |
| I _{TX-DIFF} | Current consumption TX differential | 868 MHz, 15 dBm, CW, Note 2 RF frequency generation subsystem: Internal VCO and internal loop-filter Antenna configuration: Differential PA, internal RX/TX switch | | 55 | | mA |

2. Measured with optimized matching networks.

AXM0F243

Table 5. SUPPLIES

| Sym | Description | Condition | Min | Typ | Max | Units |
|--------------------|--|---|-----|-----|-----|-------|
| I _{TX_SE} | Current consumption TX single ended | 868 MHz, 0 dBm, FSK, Note 2 RF frequency generation subsystem: Internal VCO and internal loop-filter Antenna configuration: Single ended PA, external RX/TX switching | | 7.6 | | mA |
| I _{WOR} | Typical wake-on-radio duty cycle current | 1 s, 100 kbps | | 6 | | μA |

2. Measured with optimized matching networks.

For information on current consumption in complex modes of operation tailored to your application, see the software AX-RadioLab.

Both AXM0F243 power amplifiers run from the regulated VDDA supply and not directly from the battery. This has the advantage that the current and output power do not vary much over supply voltage and temperature.

Table 6. AC SPECIFICATIONS

| Parameter | Description | Min | Typ | Max | Units | Details/ Conditions |
|---------------------------------------|---------------------------------|-----|-----|-----|-------|------------------------|
| F _{CPU} | CPU frequency | DC | – | 48 | MHz | |
| T _{SLEEP} ^[3] | CPU Wakeup from Sleep mode | – | 0 | – | μs | |
| T _{DEEPSLEEP} ^[3] | CPU Wakeup from Deep Sleep mode | – | 35 | – | | |

3. Guaranteed by characterization.

AXM0F243

GPIO

Table 7. GPIO DC SPECIFICATIONS

| Parameter | Description | Min | Typ | Max | Units | Details/ Conditions |
|---------------------------|---|-------------------------|-----|------------------------|-------|--|
| V _{IH} [4] | Input voltage high threshold | 0.7 × V _{DDD} | – | – | V | CMOS Input |
| V _{IL} | Input voltage low threshold | – | – | 0.3 × V _{DDD} | | CMOS Input |
| V _{IH} [4] | LVTTL input, V _{DDD} < 2.7 V | 0.7 × V _{DDD} | – | – | | – |
| V _{IL} | LVTTL input, V _{DDD} < 2.7 V | – | – | 0.3 × V _{DDD} | | – |
| V _{IH} [4] | LVTTL input, V _{DDD} ≥ 2.7 V | 2.0 | – | – | | – |
| V _{IL} | LVTTL input, V _{DDD} ≥ 2.7 V | – | – | 0.8 | | – |
| V _{OH} | Output voltage high level | V _{DDD} – 0.6 | – | – | | I _{OH} = 4 mA at 3 V V _{DDD} |
| V _{OH} | Output voltage high level | V _{DDD} – 0.5 | – | – | | I _{OH} = 1 mA at 1.8 V V _{DDD} |
| V _{OL} | Output voltage low level | – | – | 0.6 | | I _{OL} = 4 mA at 1.8 V V _{DDD} |
| V _{OL} | Output voltage low level | – | – | 0.6 | | I _{OL} = 10 mA at 3 V V _{DDD} |
| V _{OL} | Output voltage low level | – | – | 0.4 | | I _{OL} = 3 mA at 3 V V _{DDD} |
| R _{PULLUP} | Pull-up resistor | 3.5 | 5.6 | 8.5 | | kΩ |
| R _{PULLDOWN} | Pull-down resistor | 3.5 | 5.6 | 8.5 | – | |
| I _{IL} | Input leakage current (absolute value) | – | – | 1 | μA | 25°C, V _{DDD} = 3.0 V |
| C _{IN} | Input capacitance | – | – | 7 | pF | – |
| V _{HYSTTL} [5] | Input hysteresis LVTTL | 25 | 40 | – | mV | V _{DDD} ≥ 2.7 V |
| V _{HYS-CMOS} [5] | Input hysteresis CMOS | 0.05 × V _{DDD} | – | – | | – |
| I _{TOT_GPIO} [5] | Maximum total source or sink chip current | – | – | 200 | mA | – |

4. V_{IH} must not exceed V_{DDD} + 0.2 V

5. Guaranteed by characterization.

Table 8. GPIO AC SPECIFICATIONS *

| Parameter | Description | Min | Typ | Max | Units | Details/ Conditions |
|-----------------------|--|-----|-----|------|-------|---|
| T _{RISEF} | Rise time in fast strong mode | 2 | – | 12 | ns | 3.3 V V _{DDD} , Cload = 25 pF |
| T _{FALLF} | Fall time in fast strong mode | 2 | – | 12 | | 3.3 V V _{DDD} , Cload = 25 pF |
| T _{RISES} | Rise time in slow strong mode | 10 | – | 60 | – | 3.3 V V _{DDD} , Cload = 25 pF |
| T _{FALLS} | Fall time in slow strong mode | 10 | – | 60 | – | 3.3 V V _{DDD} , Cload = 25 pF |
| F _{GPIOOUT1} | GPIO F _{OUT} ; 3.3 V ≤ V _{DDD} ≤ 3.6 V Fast strong mode | – | – | 33 | MHz | 90/10%, 25 pF load, 60/40 duty cycle |
| F _{GPIOOUT2} | GPIO F _{OUT} ; 1.8 V ≤ V _{DDD} ≤ 3.3 V Fast strong mode | – | – | 16.7 | | 90/10%, 25 pF load, 60/40 duty cycle |
| F _{GPIOOUT3} | GPIO F _{OUT} ; 3.3 V ≤ V _{DDD} ≤ 3.6 V Slow strong mode | – | – | 7 | | 90/10%, 25 pF load, 60/40 duty cycle |
| F _{GPIOOUT4} | GPIO F _{OUT} ; 1.8 V ≤ V _{DDD} ≤ 3.3 V Slow strong mode | – | – | 3.5 | | 90/10%, 25 pF load, 60/40 duty cycle |
| F _{GPIOIN} | GPIO input operating frequency; 1.8 V ≤ V _{DDD} ≤ 3.6 V | – | – | 48 | | 90/10% V _{IO} |

*Guaranteed by characterization.

AXM0F243

XRES

Table 9. XRES DC SPECIFICATIONS

| Parameter | Description | Min | Typ | Max | Units | Details/ Conditions |
|--------------------------|------------------------------|------------------------|-----|------------------------|-------|---------------------|
| V _{IH} | Input voltage high threshold | 0.7 × V _{DDD} | – | – | V | CMOS Input |
| V _{IL} | Input voltage low threshold | – | – | 0.3 × V _{DDD} | | CMOS Input |
| R _{PULLUP} | Pull-up resistor | – | 60 | – | kΩ | |
| C _{IN} | Input capacitance | – | – | 7 | pF | |
| V _{HYSXRES} [6] | Input voltage hysteresis | – | 100 | – | mV | |

Table 10. XRES AC SPECIFICATIONS

| Parameter | Description | Min | Typ | Max | Units | Details/ Conditions |
|-----------------------------|---------------------------------|-----|-----|-----|-------|---------------------|
| T _{RESETWIDTH} [6] | Reset pulse width | 1 | – | – | μs | |
| T _{RESETWAKE} [6] | Wake-up time from reset release | – | – | 2.7 | ms | |

6. Guaranteed by characterization.

Table 11. SYSCLK DC SPECIFICATIONS

| Parameter | Description | Min | Typ | Max | Units | Details/ Conditions |
|---------------------|------------------------------|-----|-----|-----|-------|--|
| V _{IL} | Input voltage low threshold | – | – | 0.8 | V | at 3.3 V V _{DDD} |
| V _{IH} | Input voltage high threshold | 2.0 | – | – | V | at 3.3 V V _{DDD} |
| R _{PULLUP} | Pull-up resistor | – | 65 | – | kΩ | |
| V _{OL} | Output voltage low level | – | – | 0.4 | V | I _{OL} = 4 mA at 3 V V _{DDD} |
| V _{OH} | Output voltage high level | 2.4 | – | – | V | I _{OH} = 4 mA at 3 V V _{DDD} |

Analog Peripherals

Table 12. CTBm OPAMP SPECIFICATIONS

| Parameter | Description | Min | Typ | Max | Units | Details/ Conditions |
|--------------------------|---|-----|------|-----|-------|---|
| I _{DD} | Opamp block current, External load | | | | | |
| I _{DD_HI} | power=hi | – | 1100 | – | μA | – |
| I _{DD_MED} | power=med | – | 550 | – | | – |
| I _{DD_LOW} | power=lo | – | 150 | – | | – |
| GBW | Load = 20 pF, 0.1 mA V _{DDD} = 2.7 V | | | | | |
| GBW_HI | power=hi | 6 | – | – | MHz | Input and output are 0.2 V to V _{DDD} –0.2 V |
| GBW_MED | power=med | 3 | – | – | | Input and output are 0.2 V to V _{DDD} –0.2 V |
| GBW_LO | power=lo | – | 1 | – | | Input and output are 0.2 V to V _{DDD} –0.2 V |
| I _{OUT_MAX} | V _{DDD} = 2.7 V, 500 mV from rail | | | | | |
| I _{OUT_MAX_HI} | power=hi | 10 | – | – | mA | Output is 0.5 V V _{DDD} –0.5 V |
| I _{OUT_MAX_MID} | power=mid | 10 | – | – | | Output is 0.5 V V _{DDD} –0.5 V |
| I _{OUT_MAX_LO} | power=lo | – | 5 | – | | Output is 0.5 V V _{DDD} –0.5 V |
| I _{OUT} | V _{DDD} = 1.8 V, 500 mV from rail | | | | | |

AXM0F243

Table 12. CTBm OPAMP SPECIFICATIONS

| Parameter | Description | Min | Typ | Max | Units | Details/ Conditions |
|-------------------------|--|-------|------|-----------|-------|--|
| IOUT_MAX_HI | power=hi | 4 | – | – | mA | Output is 0.5 V VDDD–0.5 V |
| IOUT_MAX_MID | power=mid | 4 | – | – | | Output is 0.5 V VDDD–0.5 V |
| IOUT_MAX_LO | power=lo | – | 2 | – | | Output is 0.5 V VDDD–0.5 V |
| I _{DD_Int} | Opamp block current Internal Load | | | | | |
| I _{DD_HI_Int} | power=hi | – | 1500 | – | μA | – |
| I _{DD_MED_Int} | power=med | – | 700 | – | | – |
| I _{DD_LOW_Int} | power=lo | – | – | – | | – |
| GBW | VDDD = 2.7 V | – | – | – | | – |
| GBW_HI_Int | power=hi | 8 | – | – | MHz | Output is 0.25 V to VDDD–0.25 V |
| | General opamp specs for both internal and external modes | | | | | |
| V _{IN} | Charge–pump on, VDDD = 2.7 V | –0.05 | – | VDDD–0.2 | V | – |
| V _{CM} | Charge–pump on, VDDD = 2.7 V | –0.05 | – | VDDD–0.2 | | – |
| V _{OUT} | VDDD = 2.7 V | | | | | |
| V _{OUT_1} | power=hi, Iload=10 mA | 0.5 | – | VDDD –0.5 | V | – |
| V _{OUT_2} | power=hi, Iload=1 mA | 0.2 | – | VDDD –0.2 | | – |
| V _{OUT_3} | power=med, Iload=1 mA | 0.2 | – | VDDD –0.2 | | – |
| V _{OUT_4} | power=lo, Iload=0.1 mA | 0.2 | – | VDDD –0.2 | | – |
| V _{OS_TR} | Offset voltage, trimmed | –1.0 | ±0.5 | 1.0 | mV | High mode, input 0 V to VDDD–0.2 V |
| V _{OS_TR} | Offset voltage, trimmed | – | ±1 | – | | Medium mode, input 0 V to VDDD–0.2 V |
| V _{OS_TR} | Offset voltage, trimmed | – | ±2 | – | | Low mode, input 0 V to VDDD–0.2 V |
| V _{OS_DR_TR} | Offset voltage drift, trimmed | –10 | ±3 | 10 | μV/C | High mode |
| V _{OS_DR_TR} | Offset voltage drift, trimmed | – | ±10 | – | μV/C | Medium mode |
| V _{OS_DR_TR} | Offset voltage drift, trimmed | – | ±10 | – | | Low mode |
| CMRR | DC | 70 | 80 | – | dB | Input is 0 V to VDDD–0.2 V, Output is 0.2 V to VDDD–0.2 V |
| PSRR | At 1 kHz, 10–mV ripple | 70 | 85 | – | | V _{DD} = 3.6 V, high–power mode, input is 0.2 V to VDDD–0.2 V |

AXM0F243

Table 12. CTBm OPAMP SPECIFICATIONS

| Parameter | Description | Min | Typ | Max | Units | Details/ Conditions |
|-----------------|--|-----|------|-----|---------|---|
| Noise | | | | | | |
| VN2 | Input-referred, 1 kHz, power=Hi | – | 72 | – | nV/rtHz | 3 |
| VN3 | Input-referred, 10 kHz, power=Hi | – | 28 | – | | Input and output are at 0.2 V to VDDD–0.2 V |
| VN4 | Input-referred, 100 kHz, power=Hi | – | 15 | – | | Input and output are at 0.2 V to VDDD–0.2 V |
| CLOAD | Stable up to max. load. Performance specs at 50 pF. | – | – | 125 | pF | – |
| SLEW_RATE | Clload = 50 pF, Power = High, VDDD = 2.7 V | 6 | – | – | V/μs | – |
| T_OP_WAKE | From disable to enable, no external RC dominating | – | – | 25 | μs | – |
| OL_GAIN | Open Loop Gain | – | 90 | – | dB | – |
| COMP_MODE | Comparator mode; 50 mV drive, T _{rise} =T _{fall} (approx.) | | | | | |
| TPD1 | Response time; power=hi | – | 150 | – | ns | Input is 0.2 V to VDDD–0.2 V |
| TPD2 | Response time; power=med | – | 500 | – | | Input is 0.2 V to VDDD–0.2 V |
| TPD3 | Response time; power=lo | – | 2500 | – | | Input is 0.2 V to VDDD–0.2 V |
| VHYST_OP | Hysteresis | – | 10 | – | mV | – |
| WUP_CTB | Wake-up time from Enabled to Usable | – | – | 25 | μs | – |
| Deep Sleep Mode | Mode 2 is lowest current range. Mode 1 has higher GBW. | | | | | |
| IDD_HI_M1 | Mode 1, High current | – | 1400 | – | μA | 25°C |
| IDD_MED_M1 | Mode 1, Medium current | – | 700 | – | | 25°C |
| IDD_LOW_M1 | Mode 1, Low current | – | 200 | – | | 25°C |
| IDD_HI_M2 | Mode 2, High current | – | 120 | – | | 25°C |
| IDD_MED_M2 | Mode 2, Medium current | – | 60 | – | | 25°C |
| IDD_LOW_M2 | Mode 2, Low current | – | 15 | – | | 25°C |

AXM0F243

Table 12. CTBm OPAMP SPECIFICATIONS

| Parameter | Description | Min | Typ | Max | Units | Details/ Conditions |
|-------------|------------------------|-----|-----|-----|-------|--|
| GBW_HI_M1 | Mode 1, High current | – | 4 | – | MHz | 20-pF load, no DC load 0.2 V to V _{DDD} -0.2 V |
| GBW_MED_M1 | Mode 1, Medium current | – | 2 | – | | 20-pF load, no DC load 0.2 V to V _{DDD} -0.2 V |
| GBW_LOW_M1 | Mode 1, Low current | – | 0.5 | – | | 20-pF load, no DC load 0.2 V to V _{DDD} -0.2 V |
| GBW_HI_M2 | Mode 2, High current | – | 0.5 | – | | 20-pF load, no DC load 0.2 V to V _{DDD} -0.2 V |
| GBW_MED_M2 | Mode 2, Medium current | – | 0.2 | – | | 20-pF load, no DC load 0.2 V to V _{DDD} -0.2 V |
| GBW_LOW_M2 | Mode 2, Low current | – | 0.1 | – | | 20-pF load, no DC load 0.2 V to V _{DDD} -0.2 V |
| VOS_HI_M1 | Mode 1, High current | – | 5 | – | mV | With trim 25°C, 0.2 V to V _{DDD} -0.2 V |
| VOS_MED_M1 | Mode 1, Medium current | – | 5 | – | | With trim 25°C, 0.2 V to V _{DDD} -0.2 V |
| VOS_LOW_M2 | Mode 1, Low current | – | 5 | – | | With trim 25°C, 0.2 V to V _{DDD} -0.2 V |
| VOS_HI_M2 | Mode 2, High current | – | 5 | – | | With trim 25°C, 0.2V to V _{DDD} -0.2 V |
| VOS_MED_M2 | Mode 2, Medium current | – | 5 | – | | With trim 25°C, 0.2 V to V _{DDD} -0.2 V |
| VOS_LOW_M2 | Mode 2, Low current | – | 5 | – | | With trim 25°C, 0.2 V to V _{DDD} -0.2 V |
| IOUT_HI_M1 | Mode 1, High current | – | 10 | – | mA | Output is 0.5 V to V _{DDD} -0.5 V |
| IOUT_MED_M1 | Mode 1, Medium current | – | 10 | – | | Output is 0.5 V to V _{DDD} -0.5 V |
| IOUT_LOW_M1 | Mode 1, Low current | – | 4 | – | | Output is 0.5 V to V _{DDD} -0.5 V |
| IOUT_HI_M2 | Mode 2, High current | – | 1 | – | | |
| IOUT_MED_M2 | Mode 2, Medium current | – | 1 | – | | |
| IOUT_LOW_M2 | Mode 2, Low current | – | 0.5 | – | | |

Table 13. COMPARATOR DC SPECIFICATIONS

| Parameter | Description | Min | Typ | Max | Units | Details/ Conditions |
|----------------------|---|-----|-----|------------------------|-------|--------------------------------------|
| V _{OFFSET1} | Input offset voltage, Factory trim | – | – | ±10 | mV | |
| V _{OFFSET2} | Input offset voltage, Custom trim | – | – | ±4 | | |
| V _{HYST} | Hysteresis when enabled | – | 10 | 35 | | |
| V _{ICM1} | Input common mode voltage in normal mode | 0 | – | V _{DDD} -0.1 | V | Modes 1 and 2 |
| V _{ICM2} | Input common mode voltage in low power mode | 0 | – | V _{DDD} | | |
| V _{ICM3} | Input common mode voltage in ultra low power mode | 0 | – | V _{DDD} -1.15 | | V _{DDD} ≥ 2.2 V at -40°C |

AXM0F243

Table 13. COMPARATOR DC SPECIFICATIONS

| | | | | | | |
|-------|---------------------------------------|----|---|-----|------------------|----------------------------|
| CMRR | Common mode rejection ratio | 50 | – | – | dB | $V_{DD} \geq 2.7\text{ V}$ |
| CMRR | Common mode rejection ratio | 42 | – | – | | $V_{DD} \leq 2.7\text{ V}$ |
| ICMP1 | Block current, normal mode | – | – | 400 | μA | |
| ICMP2 | Block current, low power mode | – | – | 100 | | |
| ICMP3 | Block current in ultra low-power mode | – | – | 6 | | |
| ZCMP | DC Input impedance of comparator | 35 | – | – | $\text{M}\Omega$ | |

Table 14. COMPARATOR AC SPECIFICATIONS

| Parameter | Description | Min | Typ | Max | Units | Details/ Conditions |
|-----------|---|-----|-----|-----|---------------|---|
| TRESP1 | Response time, normal mode, 50 mV overdrive | – | 38 | 110 | ns | |
| TRESP2 | Response time, low power mode, 50 mV overdrive | – | 70 | 200 | | |
| TRESP3 | Response time, ultra-low power mode, 200 mV overdrive | – | 2.3 | 15 | μs | $V_{DD} \geq 2.2\text{ V}$ at -40°C |

Table 15. TEMPERATURE SENSOR SPECIFICATIONS

| Parameter | Description | Min | Typ | Max | Units | Details/ Conditions |
|-----------|-----------------------------|-----|---------|-----|------------------|-----------------------------|
| TSSENSACC | Temperature sensor accuracy | –5 | ± 1 | 5 | $^\circ\text{C}$ | –40 to +85 $^\circ\text{C}$ |

Table 16. SAR SPECIFICATIONS

| Parameter | Description | Min | Typ | Max | Units | Details/ Conditions |
|-----------|-------------|-----|-----|-----|-------|---------------------|
|-----------|-------------|-----|-----|-----|-------|---------------------|

SAR ADC DC Specifications

| | | | | | | |
|-----------|-------------------------------------|-----|---|-----------|------------------|-----------------------------|
| A_RES | Resolution | – | – | 12 | bits | |
| A-MONO | Monotonicity | – | – | – | | Yes. |
| A_GAINERR | Gain error | – | – | ± 0.1 | % | With external reference. |
| A_OFFSET | Input offset voltage | – | – | 2 | mV | Measured with 1-V reference |
| A_ISAR | Current consumption | – | – | 1 | mA | |
| A_VINS | Input voltage range – single ended | VSS | – | VDDD | V | |
| A_VIND | Input voltage range – differential[| VSS | – | VDDD | V | |
| A_INRES | Input resistance | – | – | 2.2 | $\text{K}\Omega$ | |
| A_INCAP | Input capacitance | – | – | 10 | pF | |

SAR ADC AC Specifications

| | | | | | | |
|--------|---|------|---|---------------------|-------|--------------------------------------|
| A_PSRR | Power supply rejection ratio | 70 | – | – | dB | |
| A_CMRR | Common mode rejection ratio | 66 | – | – | dB | Measured at 1 V |
| A_SAMP | Sample rate | – | – | 1 | Msp/s | |
| A_SNR | Signal-to-noise and distortion ratio (SINAD) | 65 | – | – | dB | $F_{IN} = 10\text{ kHz}$ |
| A_BW | Input bandwidth without aliasing | – | – | $A_{\text{samp}}/2$ | kHz | |
| A_INL | Integral non linearity $V_{DD} = 1.8\text{ V}$ to 3.6 V , 1 Msp/s | –1.7 | – | 2 | LSB | $V_{REF} = 1\text{ V}$ to V_{DD} |
| A_INL | Integral non linearity. $V_{DD} = 1.8\text{ V}$ to 3.6 V , 1 Msp/s | –1.5 | – | 1.7 | LSB | $V_{REF} = 1.8\text{ V}$ to V_{DD} |
| A_INL | Integral non linearity. $V_{DD} = 1.8\text{ V}$ to 3.6 V , 500 ksp/s | –1.5 | – | 1.7 | LSB | $V_{REF} = 1\text{ V}$ to V_{DD} |
| A_DNL | Differential non linearity. $V_{DD} = 1.8\text{ V}$ to 3.6 V , 1 Msp/s | –1 | – | 2.2 | LSB | $V_{REF} = 1\text{ V}$ to V_{DD} |

AXM0F243

Table 16. SAR SPECIFICATIONS

| | | | | | | |
|-------------|--|----|---|-----|------|------------------------------------|
| A_DNL | Differential non linearity. $V_{DD} = 1.8\text{ V to }3.6\text{ V}$, 1 Msps | -1 | - | 2 | LSB | $V_{REF} = 1.8\text{ V to }V_{DD}$ |
| A_DNL | Differential non linearity. $V_{DD} = 1.8\text{ V to }3.6\text{ V}$, 500 ksps | -1 | - | 2.2 | LSB | $V_{REF} = 1\text{ V to }V_{DD}$ |
| A_THD | Total harmonic distortion | - | - | -65 | dB | $F_{in} = 10\text{ kHz}$ |
| FSARINTRE F | SAR operating speed without external ref. bypass | - | - | 100 | ksps | 12-bit resolution |

Table 17. CSD AND IDAC SPECIFICATIONS

| Parameter | Description | Min | Typ | Max | Units | Details / Conditions |
|----------------|--|-----|-----|-----------------|-------|---|
| VDD_RIPPLE | Max allowed ripple on power supply, DC to 10 MHz | - | - | ±50 | mV | $V_{DD} > 2\text{ V}$ (with ripple), $25^\circ\text{C } T_A$, Sensitivity = 0.1 pF |
| VDD_RIPPLE_1.8 | Max allowed ripple on power supply, DC to 10 MHz | - | - | ±25 | mV | $V_{DD} > 1.75\text{ V}$ (with ripple), $25^\circ\text{C } T_A$, Parasitic Capacitance (C_p) < 20 pF, Sensitivity ≥ 0.4 pF |
| ICSD | Maximum block current | - | - | 4000 | μA | Maximum block current for both IDACs in dynamic (switching) mode including comparators, buffer, and reference generator. |
| VREF | Voltage reference for CSD and Comparator | 0.6 | 1.2 | $V_{DDD} - 0.6$ | V | $V_{DDD} - 0.06$ or 4.4, whichever is lower |
| VREF_EXT | External Voltage reference for CSD and Comparator | 0.6 | | $V_{DDD} - 0.6$ | V | $V_{DDD} - 0.06$ or 4.4, whichever is lower |
| IDAC1IDD | IDAC1 (7-bits) block current | - | - | 1750 | μA | |
| IDAC2IDD | IDAC2 (7-bits) block current | - | - | 1750 | μA | |
| VCSD | Voltage range of operation | 1.8 | - | 3.6 | V | |
| VCOMPIDAC | Voltage compliance range of IDAC | 0.6 | - | $V_{DDD} - 0.6$ | V | $V_{DDD} - 0.06$ or 4.4, whichever is lower |
| IDAC1DNL | DNL | -1 | - | 1 | LSB | |
| IDAC1INL | INL | -2 | - | 2 | LSB | INL is ±5.5 LSB for $V_{DDD} < 2\text{ V}$ |
| IDAC2DNL | DNL | -1 | - | 1 | LSB | |
| IDAC2INL | INL | -2 | - | 2 | LSB | INL is ±5.5 LSB for $V_{DDD} < 2\text{ V}$ |
| SNR | Ratio of counts of finger to noise. Guaranteed by characterization | 5 | - | - | Ratio | Capacitance range of 5 to 35 pF, 0.1-pF sensitivity. All use cases. $V_{DDD} > 2\text{ V}$. |
| IDAC1CRT1 | Output current of IDAC1 (7 bits) in low range | 4.2 | - | 5.4 | μA | LSB = 37.5-nA typ. |
| IDAC1CRT2 | Output current of IDAC1 (7 bits) in medium range | 34 | - | 41 | μA | LSB = 300-nA typ. |
| IDAC1CRT3 | Output current of IDAC1 (7 bits) in high range | 275 | - | 330 | μA | LSB = 2.4-μA typ. |
| IDAC1CRT12 | Output current of IDAC1 (7 bits) in low range, 2X mode | 8 | - | 10.5 | μA | LSB = 75-nA typ. |
| IDAC1CRT22 | Output current of IDAC1 (7 bits) in medium range, 2X mode | 69 | - | 82 | μA | LSB = 600-nA typ. |
| IDAC1CRT32 | Output current of IDAC1 (7 bits) in high range, 2X mode | 540 | - | 660 | μA | LSB = 4.8-μA typ. |
| IDAC2CRT1 | Output current of IDAC2 (7 bits) in low range | 4.2 | - | 5.4 | μA | LSB = 37.5-nA typ. |

AXM0F243

Table 17. CSD AND IDAC SPECIFICATIONS

| Parameter | Description | Min | Typ | Max | Units | Details / Conditions |
|---------------|--|-----|-----|------|-------|---|
| IDAC2CRT2 | Output current of IDAC2 (7 bits) in medium range | 34 | – | 41 | μA | LSB = 300-nA typ. |
| IDAC2CRT3 | Output current of IDAC2 (7 bits) in high range | 275 | – | 330 | μA | LSB = 2.4-μA typ. |
| IDAC2CRT12 | Output current of IDAC2 (7 bits) in low range, 2X mode | 8 | – | 10.5 | μA | LSB = 75-nA typ. |
| IDAC2CRT22 | Output current of IDAC2(7 bits) in medium range, 2X mode | 69 | – | 82 | μA | LSB = 600-nA typ. |
| IDAC2CRT32 | Output current of IDAC2(7 bits) in high range, 2X mode | 540 | – | 660 | μA | LSB = 4.8-μA typ. |
| IDAC3CRT13 | Output current of IDAC in 8-bit mode in low range | 8 | – | 10.5 | μA | LSB = 37.5-nA typ. |
| IDAC3CRT23 | Output current of IDAC in 8-bit mode in medium range | 69 | – | 82 | μA | LSB = 300-nA typ. |
| IDAC3CRT33 | Output current of IDAC in 8-bit mode in high range | 540 | – | 660 | μA | LSB = 2.4-μA typ. |
| IDACOFFSET | All zeroes input | – | – | 1 | LSB | Polarity set by Source or Sink. Offset is 2 LSBs for 37.5 nA/LSB mode |
| IDACGAIN | Full-scale error less offset | – | – | ±10 | % | |
| IDACMISMATCH1 | Mismatch between IDAC1 and IDAC2 in Low mode | – | – | 9.2 | LSB | LSB = 37.5-nA typ. |
| IDACMISMATCH2 | Mismatch between IDAC1 and IDAC2 in Medium mode | – | – | 5.6 | LSB | LSB = 300-nA typ. |
| IDACMISMATCH3 | Mismatch between IDAC1 and IDAC2 in High mode | – | – | 6.8 | LSB | LSB = 2.4-μA typ. |
| IDACSET8 | Settling time to 0.5 LSB for 8-bit IDAC | – | – | 10 | μs | Full-scale transition. No external load. |
| IDACSET7 | Settling time to 0.5 LSB for 7-bit IDAC | – | – | 10 | μs | Full-scale transition. No external load. |
| CMOD | External modulator capacitor. | – | 2.2 | – | nF | 5-V rating, X7R or NP0 cap. |

Table 18. 10-BIT CSD ADC SPECIFICATIONS

| Parameter | Description | Min | Typ | Max | Units | Details/ Conditions |
|-----------|------------------------------------|------------------|-----|------------------|-------|--|
| A_RES | Resolution | – | – | 10 | bits | Auto-zeroing is required every millisecond |
| A_CHNLS_S | Number of channels – single ended | – | – | 16 | | Defined by AMUX Bus. |
| A-MONO | Monotonicity | – | – | – | Yes | |
| A_GAINERR | Gain error | – | – | ±2 | % | In V _{REF} (2.4 V) mode with V _{DDD} bypass capacitance of 10 μF |
| A_OFFSET | Input offset voltage | – | – | 3 | mV | In V _{REF} (2.4 V) mode with V _{DDD} bypass capacitance of 10 μF |
| A_ISAR | Current consumption | – | – | 0.25 | mA | |
| A_VINS | Input voltage range – single ended | V _{SSA} | – | V _{DDD} | V | |
| A_INRES | Input resistance | – | 2.2 | – | KΩ | |
| A_INCAP | Input capacitance | – | 20 | – | pF | |

Table 18. 10-BIT CSD ADC SPECIFICATIONS

| Parameter | Description | Min | Typ | Max | Units | Details/ Conditions |
|-----------|--|-----|-----|------|-------|---|
| A_PSRR | Power supply rejection ratio | – | 60 | – | dB | In V _{REF} (2.4 V) mode with V _{DDD} bypass capacitance of 10 μF |
| A_TACQ | Sample acquisition time | – | 1 | – | μs | |
| A_CONV8 | Conversion time for 8-bit resolution at conversion rate = F _{clk} /(2 ^(N+2)). Clock frequency = 48 MHz. | – | – | 21.3 | μs | Does not include acquisition time. Equivalent to 44.8 ksp/s including acquisition time. |
| A_CONV10 | Conversion time for 10-bit resolution at conversion rate = F _{clk} /(2 ^(N+2)). Clock frequency = 48 MHz. | – | – | 85.3 | μs | Does not include acquisition time. Equivalent to 11.6 ksp/s including acquisition time. |
| A_SND | Signal-to-noise and Distortion ratio (SINAD) | – | 61 | – | dB | With 10-Hz input sine wave, external 2.4-V reference, V _{REF} (2.4 V) mode |
| A_BW | Input bandwidth without aliasing | – | – | 22.4 | KHz | 8-bit resolution |
| A_INL | Integral Non Linearity. 1 ksp/s | – | – | 2 | LSB | V _{REF} = 2.4 V or greater |
| A_DNL | Differential Non Linearity. 1 ksp/s | – | – | 1 | LSB | |

Digital Peripherals

Timer Counter Pulse-Width Modulator (TCPWM)

Table 19. TCPWM SPECIFICATIONS

| Parameter | Description | Min | Typ | Max | Units | Details/ Conditions |
|-----------------------|-------------------------------------|------------------|-----|----------------|-------|--|
| ITCPWM1 | Block current consumption at 3 MHz | – | – | 45 | μA | All modes (TCPWM) |
| ITCPWM2 | Block current consumption at 12 MHz | – | – | 155 | | All modes (TCPWM) |
| ITCPWM3 | Block current consumption at 48 MHz | – | – | 650 | | All modes (TCPWM) |
| TCPWM _{FREQ} | Operating frequency | – | – | F _c | MHz | F _c max = CLK_SYS Maximum = 48 MHz |
| TPWM _{ENEXT} | Input trigger pulse width | 2/F _c | – | – | ns | For all trigger events [7] |
| TPWM _{EXT} | Output trigger pulse widths | 2/F _c | – | – | | Minimum possible width of Overflow, Underflow, and CC (Counter equals Compare value) outputs |
| TCRES | Resolution of counter | 1/F _c | – | – | | Minimum time between successive counts |
| PWM _{RES} | PWM resolution | 1/F _c | – | – | | Minimum pulse width of PWM Output |
| Q _{RES} | Quadrature inputs resolution | 1/F _c | – | – | | Minimum pulse width between Quadrature phase inputs |

7. Trigger events can be Stop, Start, Reload, Count, Capture, or Kill depending on which mode of operation is selected.

I²C

Table 20. FIXED I²C DC SPECIFICATIONS *

| Parameter | Description | Min | Typ | Max | Units | Details/ Conditions |
|-------------------|---|-----|-----|-----|-------|---------------------|
| I _{I2C1} | Block current consumption at 100 kHz | – | – | 50 | μA | |
| I _{I2C2} | Block current consumption at 400 kHz | – | – | 135 | | |
| I _{I2C3} | Block current consumption at 1 Mbps | – | – | 310 | | |
| I _{I2C4} | I ² C enabled in Deep Sleep mode | – | – | 1.4 | μA | |

*Guaranteed by characterization.

Table 21. FIXED I²C AC SPECIFICATIONS *

| Parameter | Description | Min | Typ | Max | Units | Details/ Conditions |
|-------------------|-------------|-----|-----|-----|-------|---------------------|
| F _{I2C1} | Bit rate | – | – | 1 | Mbps | |

*Guaranteed by characterization.

Table 22. SPI DC SPECIFICATIONS *

| Parameter | Description | Min | Typ | Max | Units | Details/ Conditions |
|-----------|-------------------------------------|-----|-----|-----|-------|---------------------|
| ISPI1 | Block current consumption at 1 Mbps | – | – | 360 | μA | |
| ISPI2 | Block current consumption at 4 Mbps | – | – | 560 | | |
| ISPI3 | Block current consumption at 8 Mbps | – | – | 600 | | |

*Guaranteed by characterization.

Table 23. SPI AC SPECIFICATIONS *

| Parameter | Description | Min | Typ | Max | Units | Details/ Conditions |
|-----------|---|-----|-----|-----|-------|---------------------|
| FSPI | SPI Operating frequency (Master; 6X Oversampling) | – | – | 8 | MHz | – |

Fixed SPI Master Mode AC Specifications

| | | | | | | |
|------|---------------------------------------|----|---|----|----|----------------------------------|
| TDMO | MOSI Valid after SClk driving edge | – | – | 15 | ns | – |
| TDSI | MISO Valid before SClk capturing edge | 20 | – | – | | Full clock, late MISO sampling |
| THMO | Previous MOSI data hold time | 0 | – | – | | Referred to Slave capturing edge |

Fixed SPI Slave Mode AC Specifications

| | | | | | | |
|----------|---|----|---|-------------------------|----|---------------------------------------|
| TDMI | MOSI Valid before SClk Capturing edge | 40 | – | – | ns | – |
| TDSO | MISO Valid after SClk driving edge | – | – | 42 + 3*T _{CPU} | | T _{CPU} = 1/F _{CPU} |
| TDSO_EXT | MISO Valid after SClk driving edge in Ext. Clk mode | – | – | 48 | | – |
| THSO | Previous MISO data hold time | 0 | – | – | | – |
| TSELSSCK | SSEL Valid to first SCK Valid edge | – | – | 100 | ns | – |

*Guaranteed by characterization.

Table 24. UART DC SPECIFICATIONS *

| Parameter | Description | Min | Typ | Max | Units | Details/ Conditions |
|--------------------|--|-----|-----|-----|-------|---------------------|
| I _{UART1} | Block current consumption at 100 Kbps | – | – | 55 | μA | |
| I _{UART2} | Block current consumption at 1000 Kbps | – | – | 312 | μA | |

*Guaranteed by characterization.

Table 25. UART AC SPECIFICATIONS *

| Parameter | Description | Min | Typ | Max | Units | Details/ Conditions |
|-------------------|-------------|-----|-----|-----|-------|---------------------|
| F _{UART} | Bit rate | – | – | 1 | Mbps | |

*Guaranteed by characterization.

Memory

Table 26. FLASH SPECIFICATIONS

| Parameter | Description | Min | Typ | Max | Units | Details/ Conditions |
|------------------------------|--|-------|-----|-----|---------|--------------------------|
| T _{ROWWRITE} [8] | Row (block) write time (erase and program) | – | – | 20 | ms | Row (block) = 128 bytes |
| T _{ROWERASE} [8] | Row erase time | – | – | 16 | | – |
| T _{ROWPROGRAM} [8] | Row program time after erase | – | – | 4 | | – |
| T _{BULKERASE} [8] | Bulk erase time (64 KB) | – | – | 35 | | – |
| T _{DEVPROG} [8] [9] | Total device program time | – | – | 7 | Seconds | – |
| F _{END} [9] | Flash endurance | 100 K | – | – | Cycles | – |
| F _{RET} [9] | Flash retention. T _A ≤ 55°C, 100 K P/E cycles | 20 | – | – | Years | – |
| | Flash retention. T _A ≤ 85°C, 10 K P/E cycles | 10 | – | – | | – |
| T _{WS48} | Number of Wait states at 48 MHz | 2 | – | – | | CPU execution from Flash |
| T _{WS24} | Number of Wait states at 24 MHz | 1 | – | – | | CPU execution from Flash |

8. It can take as much as 20 milliseconds to write to Flash. During this time the device should not be Reset, or Flash operations will be interrupted and cannot be relied on to have completed. Reset sources include the XRES pin, software resets, CPU lockup states and privilege violations, improper power supply levels, and watchdogs. Make certain that these are not inadvertently activated.

9. Guaranteed by characterization.

System Resources

Power-on Reset (POR)

Table 27. POWER ON RESET (PRES)

| Parameter | Description | Min | Typ | Max | Units | Details/ Conditions |
|----------------------------|------------------------|------|-----|-----|-------|---------------------|
| SR_POWER_UP | Power supply slew rate | 3.3 | – | 67 | V/ms | At power-up |
| V _{RISEIPOR} [10] | Rising trip voltage | 0.80 | – | 1.5 | V | – |
| V _{FALLIPOR} [10] | Falling trip voltage | 0.70 | – | 1.4 | V | – |

10. Guaranteed by characterization.

Table 28. BROWN-OUT DETECT (BOD) FOR REGULATED DIGITAL VOLTAGE

| Parameter | Description | Min | Typ | Max | Units | Details/ Conditions |
|-----------------------------|--|------|-----|------|-------|---------------------|
| V _{FALLPPOR} [11] | BOD trip voltage in active and sleep modes | 1.48 | – | 1.62 | V | – |
| V _{FALLDPSLP} [11] | BOD trip voltage in Deep Sleep | 1.11 | – | 1.5 | V | – |

11. Guaranteed by characterization.

AXM0F243

SWD Interface

Table 29. SWD INTERFACE SPECIFICATIONS

| Parameter | Description | Min | Typ | Max | Units | Details/ Conditions |
|-------------------|--|--------|-----|-------|-------|--------------------------------------|
| F_SWCLK1 | $3.3\text{ V} \leq V_{DD} \leq 3.6\text{ V}$ | – | – | 14 | MHz | SWCLK \leq 1/3 CPU clock frequency |
| F_SWCLK2 | $1.8\text{ V} \leq V_{DD} \leq 3.3\text{ V}$ | – | – | 7 | | SWCLK \leq 1/3 CPU clock frequency |
| T_SWDI_SETUP [12] | $T = 1/f\text{ SWCLK}$ | 0.25*T | – | – | ns | – |
| T_SWDI_HOLD [12] | $T = 1/f\text{ SWCLK}$ | 0.25*T | – | – | | – |
| T_SWDO_VALID [12] | $T = 1/f\text{ SWCLK}$ | – | – | 0.5*T | | – |
| T_SWDO_HOLD [12] | $T = 1/f\text{ SWCLK}$ | 1 | – | – | | – |

12. Guaranteed by characterization.

Internal Main Oscillator

Table 30. IMO DC SPECIFICATIONS *

| Parameter | Description | Min | Typ | Max | Units | Details/ Conditions |
|-------------------|---------------------------------|-----|-----|-----|-------|---------------------|
| I _{IMO1} | IMO operating current at 48 MHz | – | – | 250 | μA | – |
| I _{IMO2} | IMO operating current at 24 MHz | – | – | 180 | μA | – |

*Guaranteed by design.

Table 31. IMO AC SPECIFICATIONS

| Parameter | Description | Min | Typ | Max | Units | Details/ Conditions |
|-------------------------|---|-----|-----|-----|-------|---------------------|
| F _{IMOTOL1} | Frequency variation at 24, 32, and 48 MHz (trimmed) | – | – | ±2 | % | – |
| T _{STARTIMO} | IMO startup time | – | – | 7 | μs | – |
| T _{JITRMSIMO2} | RMS jitter at 24 MHz | – | 145 | – | ps | – |

Internal Low-Speed Oscillator

Table 32. ILO DC SPECIFICATIONS *

| Parameter | Description | Min | Typ | Max | Units | Details/ Conditions |
|-------------------|-----------------------|-----|-----|------|-------|---------------------|
| I _{ILO1} | ILO operating current | – | 0.3 | 1.05 | μA | – |

*Guaranteed by design.

Table 33. ILO AC SPECIFICATIONS

| Parameter | Description | Min | Typ | Max | Units | Details/ Conditions |
|-----------------------------|---------------------|-----|-----|-----|-------|---------------------|
| T _{STARTILO1} [13] | ILO startup time | – | – | 2 | ms | – |
| T _{ILODUTY} [13] | ILO duty cycle | 40 | 50 | 60 | % | – |
| F _{ILOTRIM1} | ILO frequency range | 20 | 40 | 80 | kHz | – |

13. Guaranteed by characterization.

Table 34. WATCH CRYSTAL OSCILLATOR (WCO) SPECIFICATIONS

| Parameter | Description | Min | Typ | Max | Units | Details / Conditions |
|------------------|------------------------------|-----|--------|-----|-------|----------------------|
| F _{WCO} | Crystal Frequency | – | 32.768 | – | kHz | |
| F _{TOL} | Frequency tolerance | – | 50 | 250 | ppm | With 20-ppm crystal |
| ESR | Equivalent series resistance | – | 50 | – | kΩ | |
| PD | Drive Level | – | – | 1 | μW | |

AXM0F243

Table 34. WATCH CRYSTAL OSCILLATOR (WCO) SPECIFICATIONS

| | | | | | | |
|--------|-------------------------------------|---|------|------|----|--|
| TSTART | Startup time | – | – | 500 | ms | |
| CL | Crystal Load Capacitance | 6 | – | 12.5 | pF | |
| C0 | Crystal Shunt Capacitance | – | 1.35 | – | pF | |
| IWCO1 | Operating Current (high power mode) | – | – | 8 | μA | |
| IWCO2 | Operating Current (low power mode) | – | – | 1 | μA | |

Table 35. BLOCK SPECS

| Parameter | Description | Min | Typ | Max | Units | Details / Conditions |
|-----------------|------------------------------------|-----|-----|-----|---------|----------------------|
| TCLKSWITCH [13] | System clock source switching time | 3 | – | 4 | Periods | |

Table 36. SMART I/O PASS-THROUGH TIME (DELAY IN BYPASS MODE)

| Parameter | Description | Min | Typ | Max | Units | Details / Conditions |
|------------|---|-----|-----|-----|-------|----------------------|
| PRG_BYPASS | Max delay added by Smart I/O in bypass mode | – | – | 1.6 | ns | |

Table 37. CRYSTAL OSCILLATOR (RF REFERENCE OSCILLATOR)

| Symbol | Description | Condition | Min | Typ | Max | Units |
|------------------------|--|-------------------------------|----------------|----------------|-----------------|-------|
| f _{XTAL} | Crystal or frequency | Note 1, 2, 3 | 10 | 16 | 50 | MHz |
| gm _{osc} | Oscillator transconductance range | Self-regulated see note 4 | 0.2 | | 20 | mS |
| C _{osc} | Programmable tuning capacitors at pins CLK16N and CLK16P | AX5043_XTALCAP = 0x00 default | | 3 | | pF |
| | | AX5043_XTALCAP = 0x01 | | 8.5 | | pF |
| | | AX5043_XTALCAP = 0xFF | | 40 | | pF |
| C _{osc-lsb} | Programmable tuning capacitors, increment per LSB of AX5043_XTALCAP | AX5043_XTALCAP = 0x01 – 0xFF | | 0.5 | | pF |
| f _{ext} | External clock input (TCXO) | Note 2, 3, 5 | 10 | 16 | 50 | MHz |
| RIN _{osc} | Input DC impedance | | 10 | | | kΩ |
| NDIV _{SYSCLK} | Divider ratio f _{SYSCLK} = F _{XTAL} / NDIV _{SYSCLK} | | 2 ⁰ | 2 ⁴ | 2 ¹⁰ | |

1. Tolerances and start-up times depend on the crystal used. Depending on the RF frequency and channel spacing the IC must be calibrated to the exact crystal frequency using the readings of the register AX5043_TRKFREQ.
2. The choice of crystal oscillator or TCXO frequency depends on the targeted regulatory regime for TX, see separate documentation on meeting regulatory requirements.
3. To avoid spurious emission, the crystal or TCXO reference frequency should be chosen so that the RF carrier frequency is not an integer multiple of the crystal or TCXO frequency.
4. The oscillator transconductance is regulated for fastest start-up time during start-up and for lowest power during steady state oscillation. This means that values depend on the crystal used.
5. If an external clock or TCXO is used, it should be input via an AC coupling at pin CLK16P with the oscillator powered up and AX5043_XTALCAP = 000000. For detailed TCXO network recommendations depending on the TCXO output swing refer to the AX5043 Application Note: Use with a TCXO Reference Clock.

Table 38. LOW-POWER OSCILLATOR (TRANSCEIVER WAKE ON RADIO CLOCK)

| Symbol | Description | Condition | Min | Typ | Max | Units |
|-----------------------|--|---|-----|------|------|-------|
| f _{osc-slow} | Oscillator frequency slow mode LPOSC_FAST = 0 in AX5043_LPOSCCONFIG register | No calibration | 480 | 640 | 800 | Hz |
| | | Internal calibration vs. crystal clock has been performed | 630 | 640 | 650 | |
| f _{osc-fast} | Oscillator frequency fast mode LPOSC_FAST = 1 in AX5043_LPOSCCONFIG register | No calibration | 7.6 | 10.2 | 12.8 | kHz |
| | | Internal calibration vs. crystal clock has been performed | 9.8 | 10.2 | 10.8 | |

AXM0F243

Table 39. RF FREQUENCY GENERATION SUBSYSTEM (SYNTHESIZER)

| Symbol | Description | Condition | Min | Typ | Max | Units |
|-----------|---------------------|---|-----|-----|-----|-------|
| f_{REF} | Reference frequency | The reference frequency must be chosen so that the RF carrier frequency is not an integer multiple of the reference frequency | 10 | 16 | 50 | MHz |

Dividers

| | | | | | | |
|--------------|-------------------------------|--|-------|--|-------|--|
| $NDIV_{ref}$ | Reference divider ratio range | Controlled directly with bits REFDIV in register AX5043_PLLCODIV | 2^0 | | 2^3 | |
| $NDIV_m$ | Main divider ratio range | Controlled indirectly with register AX5043_FREQ | 4.5 | | 66.5 | |
| $NDIV_{RF}$ | RF divider range | Controlled directly with bit RFDIV in register AX5043_PLLCODIV | 1 | | 2 | |

Charge Pump

| | | | | | | |
|----------|---------------------|--|-----|--|------|---------|
| I_{CP} | Charge pump current | Programmable in increments of 8.5 μA via register AX5043_PLLCPI | 8.5 | | 2168 | μA |
|----------|---------------------|--|-----|--|------|---------|

Internal VCO (VCOSEL = 0)

| | | | | | | |
|-------------|---|--|-----|------|------|---------|
| f_{RF} | RF frequency range | RFDIV = 1 | 400 | | 525 | MHz |
| | | RFDIV = 0 | 800 | | 1050 | |
| f_{step} | RF frequency step | RFDIV = 1 $f_{REF} = 16.000000$ MHz | | 0.98 | | Hz |
| BW | Synthesizer loop bandwidth | The synthesizer loop bandwidth at start-up time can be programmed with the registers AX5043_PLLLOOP and AX5043_PLLCPI. For recommendations see the AX5043 Programming Manual, the AX-RadioLab software and AX5043 Application Notes on compliance with regulatory regimes. | 50 | | 500 | kHz |
| T_{start} | Synthesizer start-up time if crystal oscillator and reference are running | | 5 | | 25 | μs |
| PN868 | Synthesizer phase noise 868 MHz $f_{REF} = 48$ MHz | 10 kHz from carrier | | -95 | | dBc/Hz |
| | | 1 MHz from carrier | | -120 | | |
| PN433 | Synthesizer phase noise 433 MHz $f_{REF} = 48$ MHz | 10 kHz from carrier | | -105 | | dBc/Hz |
| | | 1 MHz from carrier | | -120 | | |

VCO with external inductors (VCOSEL = 1, VCO2INT = 1)

| | | | | | | |
|----------------|---|---------------------|----|------|-----|--------|
| f_{RFmg_lo} | RF frequency range For choice of L_{ext} values as well as VCO gains see Figure 3 and Figure 4 | RFDIV = 1 | 27 | | 262 | MHz |
| f_{RFmg_hi} | | RFDIV = 0 | 54 | | 525 | |
| PN169 | Synthesizer phase noise 169 MHz $L_{ext}=47$ nH (wire wound 0603) AX5043_RFDIV = 0, $f_{REF}= 16$ MHz Note: phase noises can be improved with higher f_{REF} | 10 kHz from carrier | | -97 | | dBc/Hz |
| | | 1 MHz from carrier | | -115 | | |

External VCO (VCOSEL = 1, VCO2INT = 0)

| | | | | | | |
|------------|--|--|----|-----|------|-----|
| f_{RF} | RF frequency range fully external VCO | Note: The external VCO frequency needs to be $2 \times f_{RF}$ | 27 | | 1000 | MHz |
| V_{amp} | Differential input amplitude at L1, L2 terminals | | | 0.7 | | V |
| V_{inL} | Input voltage levels at L1, L2 terminals | | 0 | | 1.8 | V |
| V_{ctrl} | Control voltage range | Available at FILT in external loop filter mode | 0 | | 1.8 | V |

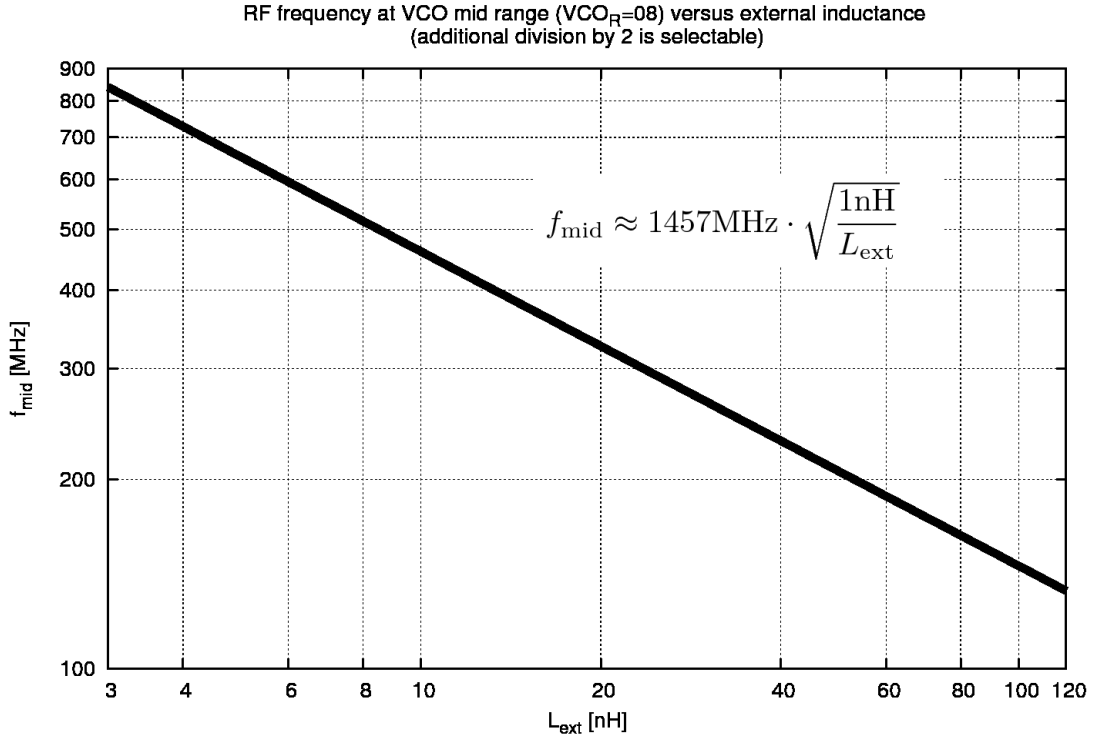

Figure 3. VCO with External Inductors: Typical Frequency vs. L_{ext}

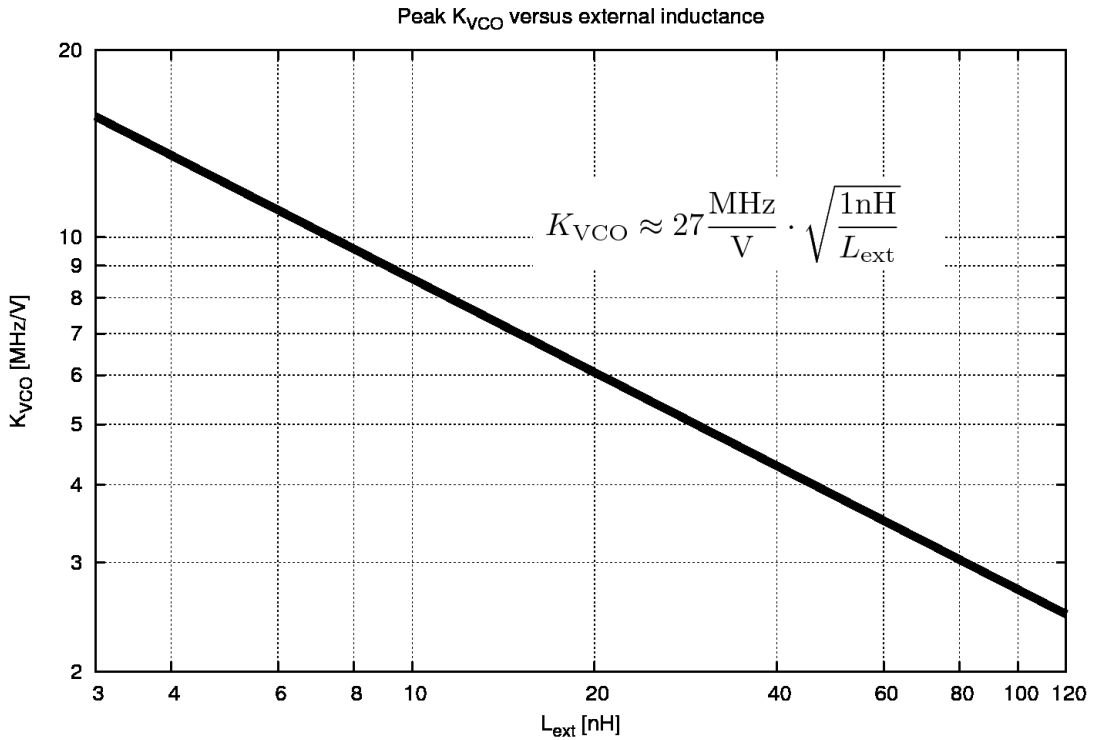

Figure 4. VCO with External Inductors: Typical K_{VCO} vs. L_{ext}

AXM0F243

The following table shows the typical frequency ranges for frequency synthesis with external VCO inductor for different inductor values.

Table 40.

| Lext [nH] | Freq [MHz] RFDIV = 0 | Freq [MHz] RFDIV = 1 | PLL Range |
|------------------|---------------------------------|---------------------------------|------------------|
| 8.2 | 482 | 241 | 0 |
| 8.2 | 437 | 219 | 15 |
| 10 | 432 | 216 | 0 |
| 10 | 390 | 195 | 15 |
| 12 | 415 | 208 | 0 |
| 12 | 377 | 189 | 15 |
| 15 | 380 | 190 | 0 |
| 15 | 345 | 173 | 15 |
| 18 | 345 | 173 | 0 |
| 18 | 313 | 157 | 15 |
| 22 | 308 | 154 | 0 |
| 22 | 280 | 140 | 14 |
| 27 | 285 | 143 | 0 |
| 27 | 258 | 129 | 15 |

| | | | |
|-----|-----|-----|----|
| 33 | 260 | 130 | 0 |
| 33 | 235 | 118 | 15 |
| 39 | 245 | 123 | 0 |
| 39 | 223 | 112 | 14 |
| 47 | 212 | 106 | 0 |
| 47 | 194 | 97 | 14 |
| 56 | 201 | 101 | 0 |
| 56 | 182 | 91 | 15 |
| 68 | 178 | 89 | 0 |
| 68 | 161 | 81 | 15 |
| 82 | 160 | 80 | 1 |
| 82 | 146 | 73 | 14 |
| 100 | 149 | 75 | 1 |
| 100 | 136 | 68 | 14 |
| 120 | 136 | 68 | 0 |
| 120 | 124 | 62 | 14 |

For tuning or changing of ranges a capacitor can be added in parallel to the inductor.

Table 41. TRANSMITTER

| Symbol | Description | Condition | Min | Typ | Max | Units |
|--------------------------|--|--|-----|-------|-----|-------|
| SBR | Signal bit rate | | 0.1 | | 125 | kbps |
| PTX | Transmitter power @ 868 MHz | Differential PA, 50 Ω single ended measurement at an SMA connector behind the matching network, Note 2 | -10 | | 16 | dBm |
| | Transmitter power @ 433 MHz | | -10 | | 16 | |
| | Transmitter power @ 169 MHz | | -10 | | 16 | |
| PTX _{step} | Programming step size output power | Note 1 | | | 0.5 | dB |
| dTX _{temp} | Transmitter power variation vs. temperature | -40°C to +85°C Note 2 | | ± 0.5 | | dB |
| dTX _{Vdd} | Transmitter power variation vs. VDD_IO | 1.8 to 3.6 V Note 2 | | ± 0.5 | | dB |
| Padj | Adjacent channel power GFSK BT = 0.5, 500 Hz deviation, 1.2 kbps, 25 kHz channel spacing, 10 kHz channel BW | 868 MHz | | -44 | | dBc |
| | | 433 MHz | | -51 | | |
| PTX _{868-harm2} | Emission @ 2 nd harmonic | 868 MHz, Note 2 | | -40 | | dBc |
| PTX _{868-harm3} | Emission @ 3 rd harmonic | | | -60 | | |
| PTX _{433-harm2} | Emission @ 2 nd harmonic | 433 MHz, Note 2 | | -40 | | dBc |
| PTX _{433-harm3} | Emission @ 3 rd harmonic | | | -40 | | |

1. $P_{out} = \frac{AX5043_TXPWRCOEFFB}{2^{12} - 1} \times P_{max}$

2. 50 Ω single ended measurements at an SMA connector behind the matching network. For recommended matching networks see Applications section.

Table 42. RECEIVER SENSITIVITIES

The table lists typical input sensitivities (without FEC) in dBm at the SMA connector with the complete matching network for BER=10⁻³ at 433 or 868 MHz.

| Data rate [kbps] | | FSK h = 0.66 | FSK h = 1 | FSK h = 2 | FSK h = 4 | FSK h = 5 | FSK h = 8 | FSK h = 16 | PSK |
|------------------|--------------------|-----------------|--------------|--------------|--------------|--------------|--------------|---------------|------|
| 0.1 | Sensitivity [dBm] | -135 | -134.5 | -132.5 | -133 | -133.5 | -133 | -132.5 | -138 |
| | RX Bandwidth [kHz] | 0.2 | 0.2 | 0.3 | 0.5 | 0.6 | 0.9 | 2.1 | 0.2 |
| | Deviation [kHz] | 0.033 | 0.05 | 0.1 | 0.2 | 0.25 | 0.4 | 0.8 | |
| 1 | Sensitivity [dBm] | -126 | -125 | -123 | -123.5 | -124 | -123.5 | -122.5 | -130 |
| | RX Bandwidth [kHz] | 1.5 | 2 | 3 | 6 | 7 | 11 | 21 | 1 |
| | Deviation [kHz] | 0.33 | 0.5 | 1 | 2 | 2.5 | 4 | 8 | |
| 10 | Sensitivity [dBm] | -117 | -116 | -113 | -114 | -113.5 | -113 | | -120 |
| | RX Bandwidth [kHz] | 15 | 20 | 30 | 50 | 60 | 110 | | 10 |
| | Deviation [kHz] | 3.3 | 5 | 10 | 20 | 25 | 40 | | |
| 100 | Sensitivity [dBm] | -107 | -105.5 | | | | | | -109 |
| | RX Bandwidth [kHz] | 150 | 200 | | | | | | 100 |
| | Deviation [kHz] | 33 | 50 | | | | | | |
| 125 | Sensitivity [dBm] | -105 | -104 | | | | | | -108 |
| | RX Bandwidth [kHz] | 187.5 | 200 | | | | | | 125 |
| | Deviation [kHz] | 42.3 | 62.5 | | | | | | |

1. Sensitivities are equivalent for 1010 data streams and PN9 whitened data streams.
 2. RX bandwidths < 0.9 kHz cannot be achieved with an 48 MHz TCXO. A 16 MHz TCXO was used for all measurements at 0.1 kbps.

AXM0F243

Table 43. RECEIVER

| Symbol | Description | Condition | Min | Typ | Max | Units |
|-------------------------|---|---|------|-------|-----|-------|
| SBR | Signal bit rate | | 0.1 | | 125 | kbps |
| IS _{BER868} | Input sensitivity at BER = 10 ⁻³ for 868 MHz operation, continuous data, without FEC | FSK, h = 0.5, 100 kbps | | -106 | | dBm |
| | | FSK, h = 0.5, 10 kbps | | -116 | | |
| | | FSK, 500 Hz deviation, 1.2 kbps | | -126 | | |
| | | PSK, 100 kbps | | -109 | | |
| | | PSK, 10 kbps | | -120 | | |
| | | PSK, 1 kbps | | -130 | | |
| IS _{BER868FEC} | Input sensitivity at BER = 10 ⁻³ , for 868 MHz operation, continuous data, with FEC | FSK, h = 0.5, 50 kbps | | -111 | | dBm |
| | | FSK, h = 0.5, 5 kbps | | -122 | | |
| | | FSK, 0.1 kbps | | -137 | | |
| IS _{PER868} | Input sensitivity at PER = 1%, for 868 MHz operation, 144 bit packet data, without FEC | FSK, h = 0.5, 100 kbps | | -103 | | dBm |
| | | FSK, h = 0.5, 10 kbps | | -115 | | |
| | | FSK, 500 Hz deviation, 1.2 kbps | | -125 | | |
| IS _{WOR868} | Input sensitivity at PER = 1% for 868 MHz operation, WOR-mode, without FEC | FSK, h = 0.5, 100 kbps | | -102 | | dBm |
| | | FSK | | 10 | | |
| CP _{1dB} | Input referred compression point | 2 tones separated by 100 kHz | | -35 | | dBm |
| RSSIR | RSSI control range | FSK, 500 Hz deviation, 1.2 kbps | -126 | | -46 | dB |
| RSSIS ₁ | RSSI step size | Before digital channel filter; calculated from register AX5043_AGCCOUNTER | | 0.625 | | dB |
| RSSIS ₂ | RSSI step size | Behind digital channel filter; calculated from registers AX5043_AGCCOUNTER, AX5043_TRKAMPL | | 0.1 | | dB |
| RSSIS ₃ | RSSI step size | Behind digital channel filter; reading register AX5043_RSSI | | 1 | | dB |
| SEL ₈₆₈ | Adjacent channel suppression | 25 kHz channels , Note 1 | | 45 | | dB |
| | | 100 kHz channels, Note 1 | | 47 | | |
| BLK ₈₆₈ | Blocking at ± 10 MHz offset | Note 2 | | 78 | | dB |
| RAFC | AFC pull-in range | The AFC pull-in range can be programmed with the AX5043_MAXR-OFFSET registers. The AFC response time can be programmed with the AX5043_FREQAIN register. | ± 15 | | | % |
| R _{DROFF} | Bitrate offset pull-in range | The bitrate pull-in range can be programmed with the AX5043_MAXDROFFSET registers. | ± 10 | | | % |

1. Interferer/Channel @ BER = 10⁻³, channel level is +3 dB above the typical sensitivity, the interfering signal is CW; channel signal is modulated with shaping
2. Channel/Blocker @ BER = 10⁻³, channel level is +3 dB above the typical sensitivity, the blocker signal is CW; channel signal is modulated with shaping

AXM0F243

Table 44. RECEIVER AND TRANSMITTER SETTLING PHASES

| Symbol | Description | Condition | Min | Typ | Max | Units |
|------------------------------|---|---|-----|---------------------------|----------------------|-------|
| T _{x_{tal}} | XTAL settling time | Powermodes: POWERDOWN to STANDBY Note that T _{x_{tal}} depends on the specific crystal used. | | 0.5 | | ms |
| T _{synth} | Synthesizer settling time | Powermodes: STANDBY to SYNTHTX or SYNTHRX | | 40 | | μs |
| T _{tx} | TX settling time | Powermodes: SYNTHTX to FULLTX T _{tx} is the time used for power ramping, this can be programmed to be 1 x t _{bit} , 2 x t _{bit} , 4 x t _{bit} or 8 x t _{bit} . Note 1 | 0 | 1 x t _{bit} | 8 x t _{bit} | μs |
| T _{rx_init} | RX initialization time | | | 150 | | μs |
| T _{rx_rssi} | RX RSSI acquisition time (after T _{rx_init}) | Powermodes: SYNTHRX to FULLRX | | 80 + 3 x t _{bit} | | μs |
| T _{rx_preamble} | RX signal acquisition time to valid data RX at full sensitivity/selectivity (after T _{rx_init}) | Modulation (G)FSK Note 1 | | 9 x t _{bit} | | |

1. t_{bit} depends on the datarate, e.g. for 10 kbps t_{bit} = 100 μs

Table 45. OVERALL STATE TRANSITION TIMES

| Symbol | Description | Condition | Min | Typ | Max | Units |
|------------------------------|---|--|-----|----------------------------|-----|-------|
| T _{tx_on} | TX startup time | Powermodes: STANDBY to FULLTX Note 1 | 40 | 40 + 1 x t _{bit} | | μs |
| T _{rx_on} | RX startup time | Powermodes: STANDBY to FULLRX | | 190 | | μs |
| T _{rx_rssi} | RX startup time to valid RSSI | Powermodes: STANDBY to FULLRX | | 270 + 3 x t _{bit} | | μs |
| T _{rx_data} | RX startup time to valid data at full sensitivity/selectivity | Modulation (G)FSK Note 1 | | 190 + 9 x t _{bit} | | μs |
| T _{rx_{tx}} | RX to TX switching | Powermodes: FULLRX to FULLTX | | 62 | | μs |
| T _{tx_{rx}} | TX to RX switching (to preamble start) | Powermodes: FULLTX to FULLRX | | 200 | | μs |
| T _{hop} | Frequency hop | Switch between frequency defined in register AX5043_FREQA and AX5043_FREQB | | 30 | | μs |

1. t_{bit} depends on the datarate, e.g. for 10 kbps t_{bit} = 100 μs

CIRCUIT DESCRIPTION

The AXM0F243 is a true single chip narrow-band, ultra-low power RF-microcontroller SoC for use in licensed and unlicensed bands ranging from 27 MHz to 1050 MHz. The on-chip transceiver consists of a fully integrated RF front-end with modulator and demodulator. Base band data processing is implemented in an advanced and flexible communication controller that enables user friendly communication.

The AXM0F243 contains a high speed Arm® Cortex®-M0+ Microcontroller. It contains 64 kBytes of FLASH and 8 kBytes of internal SRAM.

The AXM0F243 features two opamps, 12-bit 1-Msps SAR ADC with differential and single-ended modes, single-slope 10-bit ADC function, two current DACs (IDACs) for general-purpose applications on any pin, one low-power comparator that operates in Deep Sleep low-power mode, programmable logic blocks allowing Boolean operations to be performed on port inputs and outputs, two independent run-time reconfigurable Serial Communication Blocks (SCBs) with re-configurable I2C, SPI, or UART functionality, five 16-bit timer/counter/pulse-width modulator (TCPWM) blocks, up to 19 Programmable GPIO Pins, a temperature sensor.

While the radio carrier/LO synthesizer can only be clocked by the crystal oscillator (carrier stability requirements dictate a high stability reference clock in the MHz range), the microcontroller and its peripherals provide extremely flexible clocking options. The system clock that clocks the microcontroller, as well as peripheral clocks, can be selected from one of the following clock sources: the crystal oscillator, the internal main oscillator (IMO) with default frequency of 24 MHz, internal low-frequency oscillator (ILO) of 40 kHz, a 32 kHz Watch Crystal

Oscillator (WCO). Clock dividers are provided to generate clocks for peripherals on a fine-grained basis.

AXM0F243 can be operated from a 1.8 V to 3.6 V power supply over a temperature range of -40°C to 85°C, it consumes 5 – 55 mA for transmitting, depending on the output power and frequency, 6.8 – 11 mA for receiving.

The AXM0F243 features make it an ideal interface for integration into various battery powered solutions such as ticketing or as transceiver for telemetric applications e.g. in sensors. As primary application, the transceiver is intended for UHF radio equipment in accordance with the European Telecommunication Standard Institute (ETSI) specification EN 300 220-1 and the US Federal Communications Commission (FCC) standard Title 47 CFR part 15 as well as Part 90. Additionally AXM0F243 is suited for systems targeting compliance with Wireless M-Bus standard EN 13757-4:2005. Wireless M-Bus frame support (S, T, R) is built-in.

The AXM0F243 sends and receives data in frames. This standard operation mode is called Frame Mode. Pre and post ambles as well as checksums can be generated automatically.

AXM0F243 supports any data rate from 0.1 kbps to 125 kbps for FSK, MSK, 4-FSK, GFSK, GMSK and ASK modulations. To achieve optimum performance for specific data rates and modulation schemes several register settings to configure the AXM0F243 are necessary, they are outlined in the following, for details see the RadioLab software which calculates the necessary register settings and the AX5043 Programming Manual.

The receiver supports multi-channel operation for all data rates and modulation schemes.

MICROCONTROLLER

CPU and Memory Subsystem

CPU

The Cortex-M0+ CPU in the AXM0F243 is part of the 32-bit MCU subsystem, which is optimized for low-power operation with extensive clock gating. Most instructions are 16 bits in length and the CPU executes a subset of the Thumb-2 instruction set. It includes a nested vectored interrupt controller (NVIC) block with eight interrupt inputs and also includes a Wakeup Interrupt Controller (WIC). The WIC can wake the processor from Deep Sleep mode, allowing power to be switched off to the main processor when the chip is in Deep Sleep mode.

The CPU also includes a debug interface, the serial wire debug (SWD) interface, which is a two-wire form of JTAG. The debug configuration used for AXM0F243 has four breakpoint (address) comparators and two watchpoint (data) comparators.

Flash

The AXM0F243 device has a flash module with a flash accelerator, tightly coupled to the CPU to improve average access times from the flash block. The low-power flash block is designed to deliver two wait-state (WS) access time at 48 MHz. The flash accelerator delivers 85% of single-cycle SRAM access performance on average.

SRAM

Eight KB of SRAM are provided with zero wait-state access at 48 MHz.

System Resources

Power System

The power system is described in detail in the section “Power”. It provides assurance that voltage levels are as required for each respective mode and either delays mode entry (for example, on power-on reset (POR)) until voltage levels are as required for proper functionality, or generates resets (for example, on brown-out detection). The AXM0F243 operates with a single external supply over the range of 1.8 to 3.6 V (internally regulated) and has three different power modes, transitions between which are managed by the power system. The AXM0F243 provides Active, Sleep, and Deep Sleep low-power modes.

All subsystems are operational in Active mode. The CPU subsystem (CPU, flash, and SRAM) is clock-gated off in Sleep mode, while all peripherals and interrupts are active with instantaneous wake-up on a wake-up event. In Deep Sleep mode, the high-speed clock and associated circuitry is switched off; wake-up from this mode takes 35 μs. The opamps can remain operational in Deep Sleep mode.

Clock System

The AXM0F243 clock system is responsible for providing clocks to all subsystems that require clocks and for switching between different clock sources without

glitching. In addition, the clock system ensures that there are no metastable conditions.

The clock system for the AXM0F243 consists of the internal main oscillator (IMO), internal low-frequency oscillator (ILO), a 32 kHz Watch Crystal Oscillator (WCO) and provision for an external clock. Clock dividers are provided to generate clocks for peripherals on a fine-grained basis. Fractional dividers are also provided to enable clocking of higher data rates for UARTs.

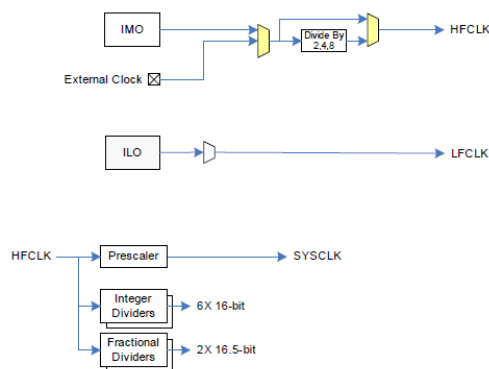

Figure 5. AXM0F243 MCU Clocking Architecture

The HFCLK signal can be divided down to generate synchronous clocks for the analog and digital peripherals. There are eight clock dividers for the AXM0F243; two of those are fractional dividers. The 16-bit capability allows flexible generation of fine-grained frequency values.

The IMO is the primary source of internal clocking in the AXM0F243. It is trimmed during testing to achieve the specified accuracy. The IMO default frequency is 24 MHz and it can be adjusted from 24 to 48 MHz in steps of 4 MHz. The IMO tolerance with provided calibration settings is ±2%.

ILO Clock Source

The ILO is a very low power, nominally 40-kHz oscillator, which is primarily used to generate clocks for the watchdog timer (WDT) and peripheral operation in Deep Sleep mode.

Watch Crystal Oscillator (WCO)

The AXM0F243 clock subsystem also implements a low-frequency (32-kHz watch crystal) oscillator that can be used for precision timing applications.

Watchdog Timer

A watchdog timer is implemented in the clock block running from the ILO; this allows watchdog operation during Deep Sleep and generates a watchdog reset if not serviced before the set timeout occurs. The watchdog reset is recorded in a Reset Cause register, which is firmware readable.

Reset

The AXM0F243 can be reset from a variety of sources including a software reset. Reset events are asynchronous and guarantee reversion to a known state. The reset cause is recorded in a register, which is sticky through reset and allows software to determine the cause of the reset. An XRES pin is reserved for external reset by asserting it active low. The XRES pin has an internal pull-up resistor that is always enabled.

Analog Blocks

12-bit SAR ADC

The 12-bit, 1-Msp/s SAR ADC can operate at a maximum clock rate of 18 MHz and requires a minimum of 18 clocks at that frequency to do a 12-bit conversion.

The Sample-and-Hold (S/H) aperture is programmable allowing the gain bandwidth requirements of the amplifier driving the SAR inputs, which determine its settling time, to be relaxed if required. It is possible to provide an external bypass (through a fixed pin location) for the internal reference amplifier.

The SAR is not available in Deep Sleep mode as it requires a high-speed clock (up to 18 MHz). The SAR operating range is 1.8 V to 3.6 V.

Two Opamps (Continuous-Time Block; CTB)

The AXM0F243 has two opamps with Comparator modes which allow most common analog functions to be performed on-chip eliminating external components; PGAs, Voltage Buffers, Filters, Trans-Impedance Amplifiers, and other functions can be realized, in some cases with external passives, saving power, cost, and space. The on-chip opamps are designed with enough bandwidth to drive the Sample-and-Hold circuit of the ADC without requiring external buffering.

Low-power Comparator (LPC)

The AXM0F243 has a low-power comparator, which can also operate in Deep Sleep modes. This allows the analog system blocks to be disabled while retaining the ability to monitor external voltage levels during low-power modes. The comparator outputs are normally synchronized to avoid metastability unless operating in an asynchronous power mode where the system wake-up circuit is activated by a comparator switch event. The LPC outputs can be routed to pins.

Current DACs

The AXM0F243 has two IDACs, which can drive any of the pins on the chip. These IDACs have programmable current ranges.

Analog Multiplexed Buses

The AXM0F243 has two concentric independent buses that go around the periphery of the chip. These buses (called amux buses) are connected to firmware-programmable analog switches that allow the chip's internal resources (IDACs, comparator) to connect to any pin on the I/O Ports.

Programmable Digital Blocks

The Programmable I/O (Smart I/O) block is a fabric of switches and LUTs that allows Boolean functions to be performed in signals being routed to the pins of a GPIO port. The Smart I/O can perform logical operations on input pins to the chip and on signals going out as outputs.

Fixed Function Digital

Timer/Counter/PWM (TCPWM) Block

The TCPWM block consists of a 16-bit counter with user-programmable period length. There is a capture register to record the count value at the time of an event (which may be an I/O event), a period register that is used to either stop or auto-reload the counter when its count is equal to the period register, and compare registers to generate compare value signals that are used as PWM duty cycle outputs. The block also provides true and complementary outputs with programmable offset between them to allow use as dead-band programmable complementary PWM outputs. It also has a Kill input to force outputs to a predetermined state; for example, this is used in motor drive systems when an over-current state is indicated and the PWM driving the FETs needs to be shut off immediately with no time for software intervention. There are five TCPWM blocks in the AXM0F243.

Serial Communication Block (SCB)

The AXM0F243 has three serial communication blocks, which can be programmed to have SPI, I²C, or UART functionality.

I²C Mode: The hardware I²C block implements a full multi-master and slave interface (it is capable of multi-master arbitration). This block is capable of operating at speeds of up to 400 kbps (Fast Mode) and has flexible buffering options to reduce interrupt overhead and latency for the CPU. It also supports EZI²C that creates a mailbox address range in the memory of the AXM0F243 and effectively reduces I²C communication to reading from and writing to an array in memory. In addition, the block supports an 8-deep FIFO for receive and transmit which, by increasing the time given for the CPU to read data, greatly reduces the need for clock stretching caused by the CPU not having read data on time.

The I²C peripheral is compatible with the I²C Standard-mode and Fast-mode devices as defined in the NXP I²C-bus specification and user manual (UM10204). The I²C bus I/O is implemented with GPIO in open-drain modes.

The AXM0F243 is not completely compliant with the I²C spec in the following respect:

- GPIO cells are not overvoltage tolerant and, therefore, cannot be hot-swapped or powered up independently of the rest of the I²C system.

UART Mode: This is a full-feature UART operating at up to 1 Mbps. It supports automotive single-wire interface

(LIN), infrared interface (IrDA), and SmartCard (ISO7816) protocols, all of which are minor variants of the basic UART protocol. In addition, it supports the 9-bit multiprocessor mode that allows addressing of peripherals connected over common RX and TX lines. Common UART functions such as parity error, break detect, and frame error are supported. An 8-deep FIFO allows much greater CPU service latencies to be tolerated.

SPI Mode: The SPI mode supports full Motorola SPI, TI SSP (adds a start pulse used to synchronize SPI Codecs), and National Microwire (half-duplex form of SPI). The SPI block can use the FIFO.

GPIO

The AXM0F243 has up to 19 GPIOs. The GPIO block implements the following:

- Eight drive modes:
 - ◆ Analog input mode (input and output buffers disabled)
 - ◆ Input only
 - ◆ Weak pull-up with strong pull-down
 - ◆ Strong pull-up with weak pull-down
 - ◆ Open drain with strong pull-down
 - ◆ Open drain with strong pull-up
 - ◆ Strong pull-up with strong pull-down
 - ◆ Weak pull-up with weak pull-down
- Input threshold select (CMOS or LVTTTL)
- Individual control of input and output buffer enabling/disabling in addition to the drive strength modes
- Selectable slew rates for dV/dt related noise control to improve EMI

The pins are organized in logical entities called ports. During power-on and reset, the blocks are forced to the disable state so as not to crowbar any inputs and/or cause excess turn-on current. A multiplexing network known as a high-speed I/O matrix is used to multiplex between various signals that may connect to an I/O pin.

Data output and pin state registers store, respectively, the values to be driven on the pins and the states of the pins themselves.

Every I/O pin can generate an interrupt if so enabled and each I/O port has an interrupt request (IRQ) and interrupt service routine (ISR) vector associated with it (5 for AXM0F243).

Power

The power system has a voltage regulator in active mode for the digital circuitry.

The supply voltage range is 1.8 V to 3.6 V (unregulated externally; internal regulator operational).

The AXM0F243 is powered by an external power supply that can be anywhere in the range of 1.8 to 3.6 V. This range is also designed for battery-powered operation. For example, the chip can be powered from a battery system that starts at 3.5 V and works down to 1.8 V, the internal regulator supplies the internal logic.

Bypass capacitors must be used from VDDD to ground. The typical practice for systems in this frequency range is to use a capacitor in the 1- μ F range, in parallel with a smaller capacitor (0.1 μ F, for example). Note that these are simply rules of thumb and that, for critical applications, the PCB layout, lead inductance, and the bypass capacitor parasitic should be simulated to design and obtain optimal bypassing.

TRANSCEIVER

The transceiver block is controllable through its registers. The transceiver block features its own 256 byte FIFO. The microcontroller can be interrupted at a programmable FIFO fill level.

RF Frequency Generation Subsystem

The RF frequency generation subsystem consists of a fully integrated synthesizer, which multiplies the reference frequency from the crystal oscillator to get the desired RF frequency. The advanced architecture of the synthesizer enables frequency resolutions of 1 Hz, as well as fast settling times of 5 – 50 μ s depending on the settings (see section AC Characteristics). Fast settling times mean fast start-up and fast RX/TX switching, which enables low-power system design.

For receive operation the RF frequency is fed to the mixer, for transmit operation to the power-amplifier.

The frequency must be programmed to the desired carrier frequency.

The synthesizer loop bandwidth can be programmed, this serves three purposes:

1. Start-up time optimization, start-up is faster for higher synthesizer loop bandwidths
2. TX spectrum optimization, phase-noise at 300 kHz to 1 MHz distance from the carrier improves with lower synthesizer loop bandwidths
3. Adaptation of the bandwidth to the data-rate. For transmission of FSK and MSK it is required that the synthesizer bandwidth must be in the order of the data-rate.

VCO

An on-chip VCO converts the control voltage generated by the charge pump and loop filter into an output frequency. This frequency is used for transmit as well as for receive operation. The frequency can be programmed in 1 Hz steps in the AX5043_FREQ registers. For operation in the 433 MHz band, the RFDIV bit in the AX5043_PLLVCODIV register must be programmed.

The fully integrated VCO allows to operate the device in the frequency ranges 800 – 1050 MHz and 400 – 520 MHz.

The carrier frequency range can be extended to 54 – 525 MHz and 27 – 262 MHz by using an appropriate external inductor between device pins L1 and L2. The bits VCO2INT and VCOSEL in the AX5043_PLLVCODIV register must be set high to enter this mode.

It is also possible to use a fully external VCO by setting bits VCO2INT = 0 and VCOSEL = 1 in the AX5043_PLLVCODIV register. A differential input at a frequency of double the desired RF frequency must be input

at device pins L1 and L2. The control voltage for the VCO can be output at device pin FILT when using external filter mode. The voltage range of this output pin is 0 – 1.8 V. This mode of operation is recommended for special applications where the phase noise requirements are not met when using the fully internal VCO or the internal VCO with external inductor.

VCO Auto-Ranging

The AXM0F243 has an integrated auto-ranging function, which allows to set the correct VCO range for specific frequency generation subsystem settings automatically. Typically it has to be executed after power-up. The function is initiated by setting the RNG_START bit in the AX5043_PLLRANGINGA or AX5043_PLLRANGINGB register. The bit is readable and a 0 indicates the end of the ranging process. Setting RNG_START in the AX5043_PLLRANGINGA register ranges the frequency in AX5043_FREQA, while setting RNG_START in the AX5043_PLLRANGINGB register ranges the frequency in AX5043_FREQB. The RNGERR bit indicates the correct execution of the auto-ranging. VCO auto-ranging works with the fully integrated VCO and with the internal VCO with external inductor.

Loop Filter and Charge Pump

The AXM0F243 internal loop filter configuration together with the charge pump current sets the synthesizer loop bandwidth. The internal loop-filter has three configurations that can be programmed via the register bits FLT[1:0] in registers AX5043_PLLLOOP or AX5043_PLLLOOPBOOST the charge pump current can be programmed using register bits PLLCPI[7:0] in registers AX5043_PLLCPI or AX5043_PLLCPIBOOST. Synthesizer bandwidths are typically 50 – 500 kHz depending on the AX5043_PLLLOOP or AX5043_PLLLOOPBOOST settings, for details see the section: AC Characteristics.

The AXM0F243 can be setup in such a way that when the synthesizer is started, the settings in the registers AX5043_PLLLOOPBOOST and AX5043_PLLCPIBOOST are applied first for a programmable duration before reverting to the settings in AX5043_PLLLOOP and AX5043_PLLCPI. This feature enables automated fastest start-up.

Setting bits FLT[1:0] = 00 bypasses the internal loop filter and the VCO control voltage is output to an external loop filter at pin FILT. This mode of operation is recommended for achieving lower bandwidths than with the internal loop filter and for usage with a fully external VCO.

Table 46. RF FREQUENCY GENERATION REGISTERS

| Register | Bits | Purpose |
|---|----------|---|
| AX5043_PLLLOOP AX5043_PLLLOOPBOOST | FLT[1:0] | Synthesizer loop filter bandwidth and selection of external loop filter, recommended usage is to increase the bandwidth for faster settling time, bandwidth increases of factor 2 and 5 are possible. |
| AX5043_PLLCPI AX5043_PLLCPIBOOST | | Synthesizer charge pump current, recommended usage is to decrease the bandwidth (and improve the phase-noise) for low data-rate transmissions. |
| AX5043_PLLVCODIV | REFDIV | Sets the synthesizer reference divider ratio. |
| | RFDIV | Sets the synthesizer output divider ratio. |
| | VCOSEL | Selects either the internal or the external VCO |
| | VCO2INT | Selects either the internal VCO inductor or an external inductor between pins L1 and L2 |
| AX5043_FREQA, AX5043_FREQB | | Programming of the carrier frequency |
| AX5043_PLLRANGINGA, AX5043_PLLRANGINGB | | Initiate VCO auto-ranging and check results |

RF Input and Output Stage (ANTP/ANTN/ANTP1)

The AXM0F243 has two main antenna interface modes:

- Both RX and TX use differential pins ANTP and ANTN. RX/TX switching is handled internally. This mode is recommended for highest output powers, highest sensitivities and for direct connection to dipole antennas. Also see Figure 10.
- RX uses the differential antenna pins ANTP and ANTN. TX uses the single ended antenna pin ANTP1. RX/TX switching is handled externally. This can be done either with an external RX/TX switch or with a direct tie configuration. This mode is recommended for low output powers at high efficiency Figure 13 and for usage with external power amplifiers Figure 12.

When antenna diversity is enabled, the radio controller will, when not in the middle of receiving a packet, periodically probe both antennas and select the antenna with the highest signal strength. The radio controller can be instructed to periodically write both RSSI values into the FIFO. Antenna diversity mode is fully automatic.

LNA

The LNA amplifies the differential RF signal from the antenna and buffers it to drive the I/Q mixer. An external matching network is used to adapt the antenna impedance to the IC impedance. A DC feed to GND must be provided at the antenna pins.

PA

In TX mode the PA drives the signal generated by the frequency generation subsystem out to either the differential antenna terminals or to the single ended antenna pin. The antenna terminals are chosen via the bits TXDIFF and TXSE in register AX5043_MODECFG.

The output power of the PA is programmed via the register AX5043_TXPWRCOEFFB.

The PA can be digitally pre-distorted for high linearity.

The output amplitude can be shaped (raised cosine), this mode is selected with bit AMPLSHAPE in register AX5043_MODECFG. PA ramping is programmable in increments of the bit time and can be set to 1 – 8 bit times via bits SLOWRAMP in register AX5043_MODECFG.

Output power as well as harmonic content will depend on the external impedance seen by the PA.

Digital IF Channel Filter and Demodulator

The digital IF channel filter and the demodulator extract the data bit-stream from the incoming IF signal. They must be programmed to match the modulation scheme as well as the data-rate. Inaccurate programming will lead to loss of sensitivity.

The channel filter offers bandwidths of 995 Hz up to 221 kHz.

The RadioLab Software calculates the necessary register settings for optimal performance. An overview of the registers involved is given in the following table as reference, for details see the AX5043 Programming Manual. The register setups typically must be done once at power-up of the device.

Table 47. CHANNEL FILTER AND DEMODULATOR REGISTERS

| Register | Remarks |
|---|--|
| AX5043_DECIMATION | This register programs the bandwidth of the digital channel filter. |
| AX5043_RXDATARATE2... AX5043_RX-DATARATE0 | These registers specify the receiver bit rate, relative to the channel filter bandwidth. |
| AX5043_MAXDROFFSET2... AX5043_MAXDROFFSET0 | These registers specify the maximum possible data rate offset |
| AX5043_MAXRFOFFSET2... AX5043_MAXR-FOFFSET0 | These registers specify the maximum possible RF frequency offset |
| AX5043_TIMEGAIN, AX5043_DRGAIN | These registers specify the aggressiveness of the receiver bit timing recovery. More aggressive settings allow the receiver to synchronize with shorter preambles, at the expense of more timing jitter and thus a higher bit error rate at a given signal-to-noise ratio. |
| AX5043_MODULATION | This register selects the modulation to be used by the transmitter and the receiver, i.e. whether ASK, FSK should be used. |
| AX5043_PHASEGAIN, AX5043_FREQGAINA, AX5043_FREQGAINB, AX5043_FREQGAINC, AX5043_FREQGAIND, AX5043_AMPLGAIN | These registers control the bandwidth of the phase, frequency offset and amplitude tracking loops. |
| AX5043_AGC_GAIN | This register controls the AGC (automatic gain control) loop slopes, and thus the speed of gain adjustments. The faster the bit-rate, the faster the AGC loop should be. |
| AX5043_TXRATE | These registers control the bit rate of the transmitter. |
| AX5043_FSKDEV | These registers control the frequency deviation of the transmitter in FSK mode. The receiver does not explicitly need to know the frequency deviation, only the channel filter bandwidth has to be set wide enough for the complete modulation to pass. |

Encoder

The encoder is located between the Framing Unit, the Demodulator and the Modulator. It can optionally transform the bit-stream in the following ways:

- It can invert the bit stream.
- It can perform differential encoding. This means that a zero is transmitted as no change in the level, and a one is transmitted as a change in the level.
- It can perform Manchester encoding. Manchester encoding ensures that the modulation has no DC content and enough transitions (changes from 0 to 1 and from 1 to 0) for the demodulator bit timing recovery to function correctly, but does so at a doubling of the data rate.
- It can perform spectral shaping (also known as whitening). Spectral shaping removes DC content of the bit stream, ensures transitions for the demodulator bit timing recovery, and makes sure that the transmitted spectrum does not have discrete lines even if the transmitted data is cyclic. It does so without adding additional bits, i.e. without changing the data rate. Spectral Shaping uses a self synchronizing feedback shift register.

The encoder is programmed using the register AX5043_ENCODING, details and recommendations on usage are given in the AX5043 Programming Manual.

Framing and FIFO

Most radio systems today group data into packets. The framing unit is responsible for converting these packets into a bit-stream suitable for the modulator, and to extract packets from the continuous bit-stream arriving from the demodulator.

The Framing unit supports two different modes:

- Packet modes
- Raw modes

The microcontroller communicates with the framing unit through a 256 byte FIFO. Data in the FIFO is organized in Chunks. The chunk header encodes the length and what data is contained in the payload. Chunks may contain packet data, but also RSSI, Frequency offset, Timestamps, etc.

The AXM0F243 contains one FIFO. Its direction is switched depending on whether transmit or receive mode is selected.

The FIFO can be operated in polled or interrupt driven modes. In polled mode, the microcontroller must periodically read the FIFO status register or the FIFO count register to determine whether the FIFO needs servicing.

In interrupt mode EMPTY, NOT EMPTY, FULL, NOT FULL and programmable level interrupts are provided. Interrupts are acknowledged by removing the cause for the interrupt, i.e. by emptying or filling the FIFO.

AXM0F243

Packet Modes

The AXM0F243 offers different packet modes. For arbitrary packet sizes HDLC is recommended since the flag and bit-stuffing mechanism. The AXM0F243 also offers packet modes with fixed packet length with a byte indicating the length of the packet.

In packet modes a CRC can be computed automatically.

HDLC Mode is the main framing mode of the AXM0F243. In this mode, the AXM0F243 performs

automatic packet delimiting, and optional packet correctness check by inserting and checking a cyclic redundancy check (CRC) field.

NOTE: HDLC mode follows High-Level Data Link Control (HDLC, ISO 13239) protocol.

The packet structure is given in the following table.

Table 48. HDLC PACKET STRUCTURE

| Flag | Address | Control | Information | FCS | (Optional Flag) |
|-------|---------|-------------|---|-------------|-----------------|
| 8 bit | 8 bit | 8 or 16 bit | Variable length, 0 or more bits in multiples of 8 | 16 / 32 bit | 8 bit |

HDLC packets are delimited with flag sequences of content 0x7E.

In AXM0F243 the meaning of address and control is user defined. The Frame Check Sequence (FCS) can be programmed to be CRC-CCITT, CRC-16 or CRC-32.

The receiver checks the CRC, the result can be retrieved from the FIFO, the CRC is appended to the received data.

In Wireless M-Bus Mode, the packet structure is given in the following table.

NOTE: Wireless M-Bus mode follows EN13757-4

Table 49. WIRELESS M-BUS PACKET STRUCTURE

| Preamble | L | C | M | A | FCS | Optional Data Block (optionally repeated with FCS) | FCS |
|----------|-------|-------|-------|-------|--------|---|--------|
| variable | 8 bit | 8 bit | 8 bit | 8 bit | 16 bit | 8 – 96 bit | 16 bit |

For details on implementing a HDLC communication as well as Wireless M-Bus please use the RadioLab software and see the AX5043 Programming Manual.

Raw Modes

In Raw mode, the AXM0F243 does not perform any packet delimiting or byte synchronization. It simply serializes transmit bytes and de-serializes the received bit-stream and groups it into bytes. This mode is ideal for implementing legacy protocols in software.

Raw mode with preamble match is similar to raw mode. In this mode, however, the receiver does not receive anything until it detects a user programmable bit pattern (called the preamble) in the receive bit-stream. When it detects the preamble, it aligns the de-serialization to it.

The preamble can be between 4 and 32 bits long.

RX AGC and RSSI

AXM0F243 features three receiver signal strength indicators (RSSI):

1. RSSI before the digital IF channel filter.

The gain of the receiver is adjusted in order to keep the analog IF filter output level inside the working range of the ADC and demodulator. The register AX5043_AGCCOUNTER contains the

current value of the AGC and can be used as an RSSI. The step size of this RSSI is 0.625 dB. The value can be used as soon as the RF frequency generation sub-system has been programmed.

2. RSSI behind the digital IF channel filter.

The register AX5043_RSSI contains the current value of the RSSI behind the digital IF channel filter. The step size of this RSSI is 1 dB.

3. RSSI behind the digital IF channel filter high accuracy. The demodulator also provides amplitude information in the AX5043_TRK_AMPLITUDE register. By combining both the AX5043_AGCCOUNTER and the AX5043_TRK_AMPLITUDE registers, a high resolution (better than 0.1 dB) RSSI value can be computed at the expense of a few arithmetic operations on the micro-controller. The RadioLab Software calculates the necessary register settings for best performance.

Modulator

Depending on the transmitter settings the modulator generates various inputs for the PA:

Table 50. MODULATIONS

| Modulation | Bit = 0 | Bit = 1 | Main Lobe Bandwidth | Max. Bitrate |
|-------------------|------------------------------------|------------------------------------|-------------------------------------|--------------|
| ASK | PA off | PA on | BW = BITRATE | 125 kBit/s |
| FSK/MSK/GFSK/GMSK | $\Delta f = -f_{\text{deviation}}$ | $\Delta f = +f_{\text{deviation}}$ | $BW = (1 + h) \cdot \text{BITRATE}$ | 125 kBit/s |
| PSK | $\Delta\Phi = 0^\circ$ | $\Delta\Phi = 180^\circ$ | BW = BITRATE | 125 kBit/s |

h = modulation index. It is the ratio of the deviation compared to the bit-rate; $f_{\text{deviation}} = 0.5 \cdot h \cdot \text{BITRATE}$, AXM0F243 can demodulate signals with $h < 32$.

ASK = amplitude shift keying

FSK = frequency shift keying

MSK= minimum shift keying; MSK is a special case of FSK, where $h = 0.5$, and therefore

$f_{\text{deviation}} = 0.25 \cdot \text{BITRATE}$; the advantage of MSK over FSK is that it can be demodulated more robustly.

PSK = phase shift keying

All modulation schemes, except 4-FSK, are binary.

Amplitude can be shaped using a raised cosine waveform. Amplitude shaping will also be performed for constant amplitude modulation ((G)FSK, (G)MSK) for ramping up and down the PA. Amplitude shaping should always be enabled.

Frequency shaping can either be hard (FSK, MSK), or Gaussian (GMSK, GFSK), with selectable BT = 0.3 or BT = 0.5.

Table 51. 4-FSK MODULATION

| Modulation | DiBit = 00 | DiBit = 01 | DiBit = 11 | DiBit = 10 | Main Lobe Bandwidth | Max. Bitrate |
|------------|-------------------------------------|------------------------------------|------------------------------------|-------------------------------------|--------------------------------------|--------------|
| 4-FSK | $\Delta f = -3f_{\text{deviation}}$ | $\Delta f = -f_{\text{deviation}}$ | $\Delta f = +f_{\text{deviation}}$ | $\Delta f = +3f_{\text{deviation}}$ | $BW = (1 + 3h) \cdot \text{BITRATE}$ | 125 kBit/s |

4-FSK Frequency shaping is always hard.

$$\Delta f = \frac{\text{AX5043_TRKRFFREQ}}{2^{32}} f_{\text{XTAL}}$$

Automatic Frequency Control (AFC)

The AXM0F243 features an automatic frequency tracking loop which is capable of tracking the transmitter frequency within the RX filter band width. On top of that the AXM0F243 has a frequency tracking register AX5043_TRKRFFREQ to synchronize the receiver frequency to a carrier signal. For AFC adjustment, the frequency offset can be computed with the following formula:

PWRMODE Register

The AXM0F243 transceiver features its own independent power management, independent from the microcontroller. While the microcontroller power mode is controlled through the PWR_CONTROL register, the AX5043_PWRMODE register controls which parts of the transceiver are operating.

Table 52. PWRMODE REGISTER

| AX5043_PWRMODE Register | Name | Description |
|-------------------------|-----------|--|
| 0000 | POWERDOWN | All digital and analog functions, except the register file, are disabled. The core supply voltages are switched off to conserve leakage power. Register contents are preserved. Access to the FIFO is not possible and the contents are not preserved. POWERDOWN mode is only entered once the FIFO is empty. |
| 0001 | DEEPSLEEP | The transceiver is fully turned off. All digital and analog functions are disabled. All register contents are lost. To leave DEEPSLEEP mode the pin SEL has to be pulled low. This will initiate startup and reset of the transceiver. Then the MISO line should be polled, as it will be held low during initialization and will rise to high at the end of the initialization, when the chip becomes ready for operation. It is recommended to use the functions ax5043_enter_deepsleep() and ax5043_wake-up_deepsleep() provided in libmf |
| 0101 | STANDBY | The crystal oscillator and the reference are powered on; receiver and transmitter are off. Register contents are preserved and accessible. Access to the FIFO is not possible and the contents are not preserved. STANDBY is only entered once the FIFO is empty. |
| 0110 | FIFO | The reference is powered on. Register contents are preserved and accessible. Access to the FIFO is possible and the contents are preserved. |

Table 52. PWRMODE REGISTER

| AX5043_PWRMODE Register | Name | Description |
|-------------------------|---------|---|
| 1000 | SYNTHRX | The synthesizer is running on the receive frequency. Transmitter and receiver are still off. This mode is used to let the synthesizer settle on the correct frequency for receive. |
| 1001 | FULLRX | Synthesizer and receiver are running. |
| 1011 | WOR | Receiver wakeup-on-radio mode. The mode the same as POWERDOWN, but the 640 Hz internal low power oscillator is running. |
| 1100 | SYNHTX | The synthesizer is running on the transmit frequency. Transmitter and receiver are still off. This mode is used to let the synthesizer settle on the correct frequency for transmit. |
| 1101 | FULLTX | Synthesizer and transmitter are running. Do not switch into this mode before the synthesizer has completely settled on the transmit frequency (in SYNHTX mode), otherwise spurious spectral transmissions will occur. |

Table 53. A TYPICAL AX5043_PWRMODE SEQUENCE FOR A TRANSMIT SESSION

| Step | PWRMODE | Remarks |
|------|-----------|--|
| 1 | POWERDOWN | |
| 2 | STANDBY | The settling time is dominated by the crystal used, typical value 3ms. |
| 3 | FULLTX | Data transmission |
| 4 | POWERDOWN | |

Table 54. A TYPICAL AX5043_PWRMODE SEQUENCE FOR A RECEIVE SESSION

| Step | PWRMODE [3:0] | Remarks |
|------|---------------|--|
| 1 | POWERDOWN | |
| 2 | STANDBY | The settling time is dominated by the crystal used, typical value 3ms. |
| 3 | FULLRX | Data reception |
| 4 | POWERDOWN | |

Voltage Regulator

The AXM0F243 transceiver uses its own dedicated on-chip voltage regulator system to create stable supply voltages for the internal circuitry from the primary supply VDD_IO. The I/O level of the digital pins is VDD_IO.

Pins VDD_ANA are supplied for external decoupling of the power supply used for the on-chip PA.

The voltage regulator system must be set into the appropriate state before receive or transmit operations can be initiated. This is handled automatically when programming the device modes via the AX5043_PWRMODE register.

Register AX5043_POWSTAT contains status bits that can be read to check if the regulated voltages are ready (bit SVIO) or if VDD_IO has dropped below the brown-out level of 1.3 V (bit SSUM).

In power-down mode the core supply voltages for digital and analog functions are switched off to minimize leakage power. Most register contents are preserved but access to the FIFO is not possible and FIFO contents are lost.

In deep-sleep mode all supply voltages are switched off. All digital and analog functions are disabled. All register contents are lost.

AXM0F243

Typical Application Diagrams

Connecting to Debug Adapter

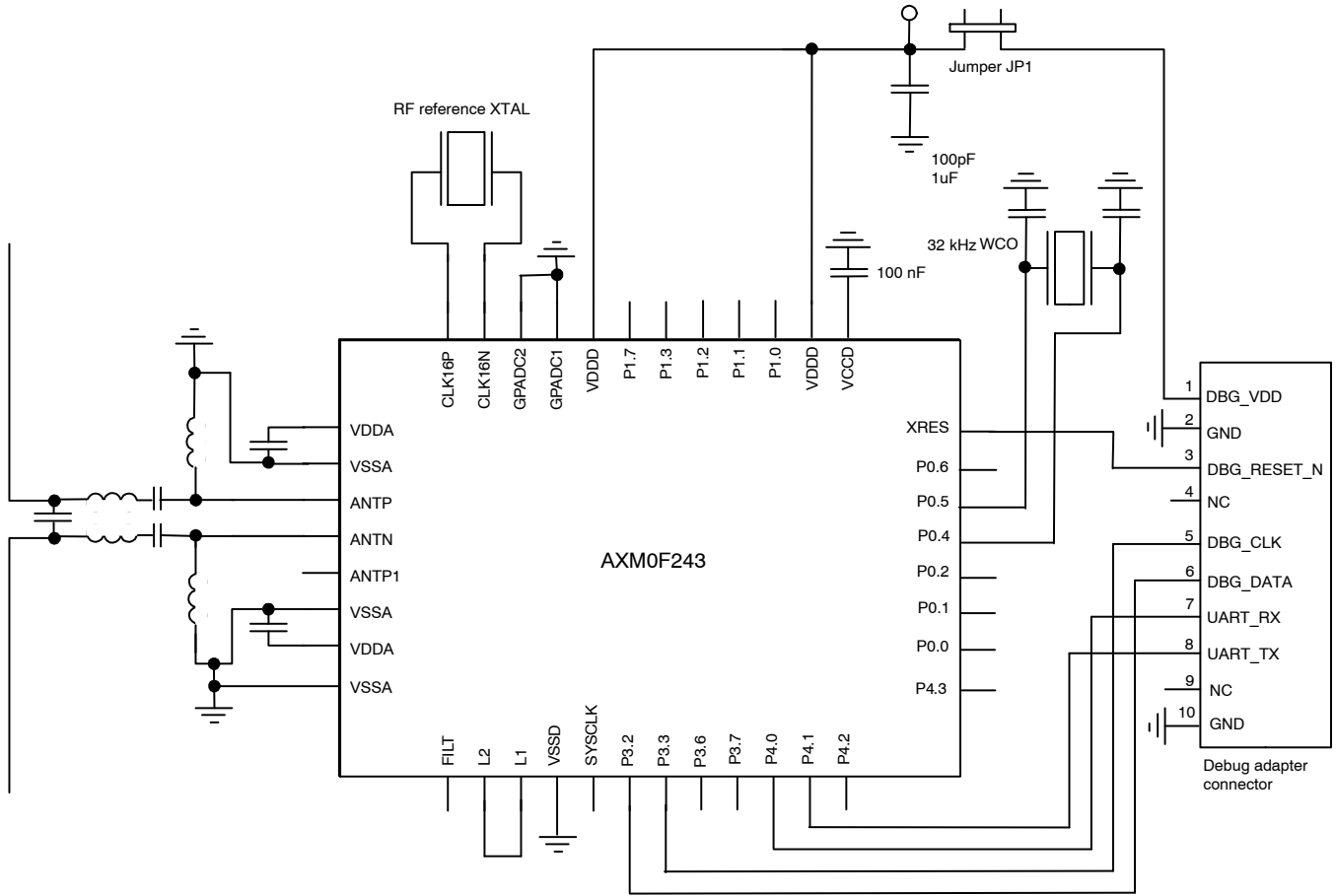

Figure 6. Typical Application Diagram with Connection to the Debug Adapter

Match to 50 Ω for Differential Antenna Pins
(868 / 433 MHz RX / TX Operation)

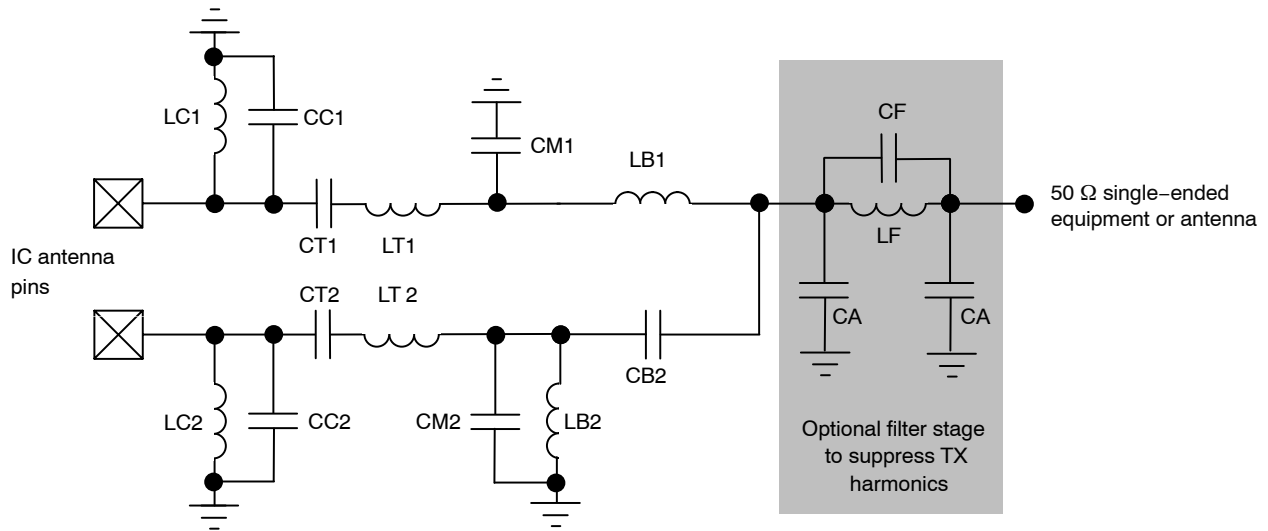

Figure 7. Structure of the Differential Antenna Interface for TX/RX Operation to 50 Ω Single-ended Equipment or Antenna

Table 55. TYPICAL COMPONENT VALUES

| Frequency Band | LC _{1,2} [nH] | CC _{1,2} [pF] | CT _{1,2} [pF] | LT _{1,2} [nH] | CM ₁ [pF] | CM ₂ [pF] | LB _{1,2} [nH] | CB ₂ [pF] | CF [pF] optional | LF [nH] optional | CA [pF] optional |
|----------------|------------------------|------------------------|------------------------|------------------------|----------------------|----------------------|------------------------|----------------------|------------------|------------------|------------------|
| 868 / 915 MHz | 18 | nc | 2.7 | 18 | 6.2 | 3.6 | 12 | 2.7 | nc | 0 Ω | nc |
| 433 MHz | 100 | nc | 4.3 | 43 | 11 | 5.6 | 27 | 5.1 | nc | 0 Ω | nc |
| 470 MHz | 100 | nc | 3.9 | 33 | 4.7 | nc | 22 | 4.7 | nc | 0 Ω | nc |
| 169 MHz | 150 | 10 | 10 | 120 | 12 | nc | 68 | 12 | 6.8 | 30 | 27 |

Match to 50 Ω for Single-ended Antenna Pin
(868 / 915 / 433 MHz TX Operation)

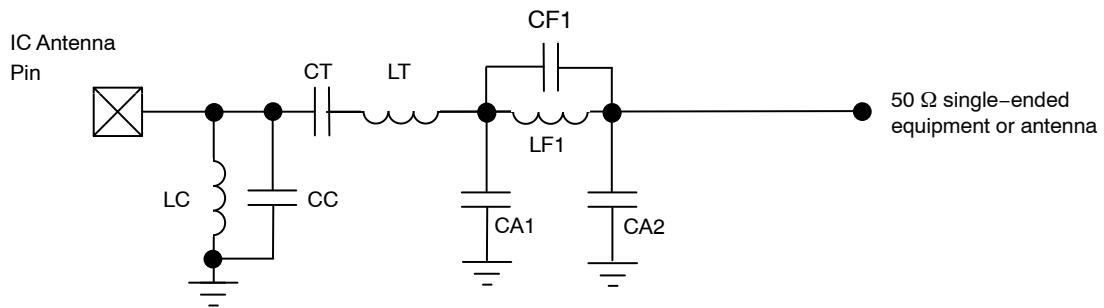

Figure 8. Structure of the Single-ended Antenna Interface for TX Operation to 50 Ω Single-ended Equipment or Antenna

Table 56. TYPICAL COMPONENT VALUES

| Frequency Band | LC [nH] | CC [pF] | CT [pF] | LT [nH] | CF ₁ [pF] | LF ₁ [nH] | CA ₁ [pF] | CA ₂ [pF] |
|----------------|---------|---------|---------|---------|----------------------|----------------------|----------------------|----------------------|
| 868 / 915 MHz | 18 | nc | 2.7 | 18 | 3.6 | 2.2 | 3.6 | nc |
| 433 MHz | 100 | nc | 4.3 | 43 | 6.8 | 4.7 | 5.6 | nc |

AXM0F243

Match to 50 Ω for Single-ended Antenna Pin
(169 MHz TX Operation)

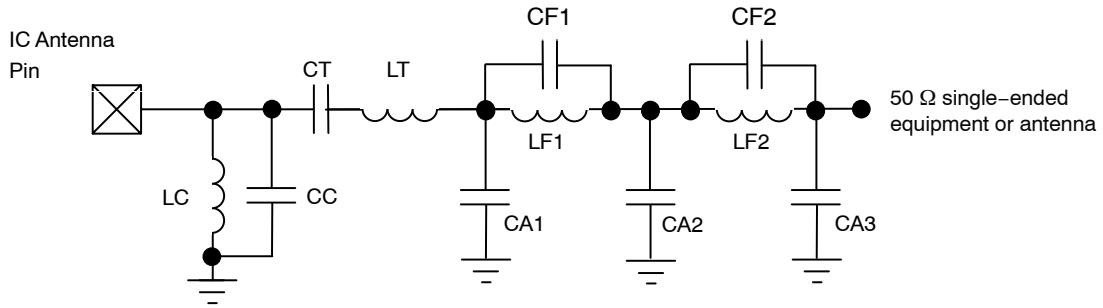

Figure 9. Structure of the Single-ended Antenna Interface for TX Operation to 50 Ω Single-ended Equipment or Antenna

Table 57. TYPICAL COMPONENT VALUES

| Frequency Band | LC [nH] | CC [pF] | CT [pF] | LT [nH] | CF1 [pF] | LF1 [nH] | CF2 [pF] | LF2 [nH] | CA1 [pF] | CA2 [pF] | CA3 [pF] |
|----------------|---------|---------|---------|---------|----------|----------|----------|----------|----------|----------|----------|
| 169 MHz | 150 | 2.2 | 22 | 120 | 4.7 | 39 | 1.8 | 47 | 33 | 47 | 15 |

Using a Dipole Antenna and the Internal TX/RX Switch

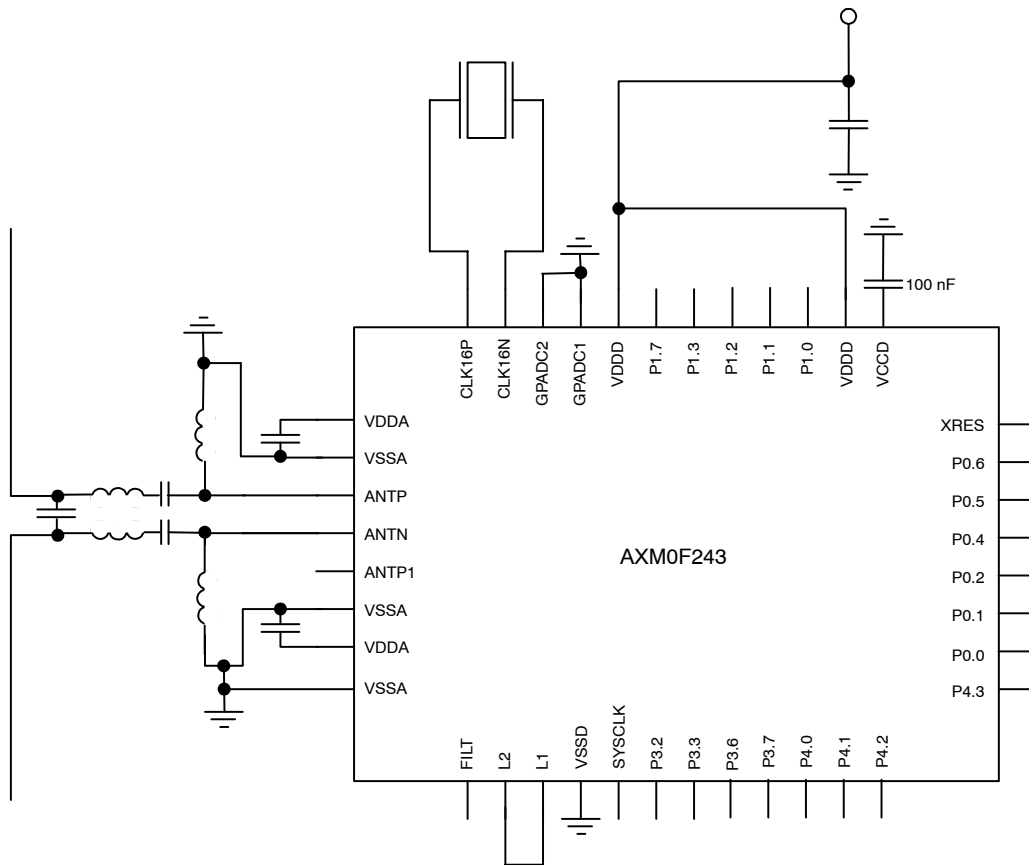

Figure 10. Typical Application Diagram with Dipole Antenna and Internal TX/RX Switch

AXM0F243

Using a Single-ended Antenna and the Internal TX/RX Switch

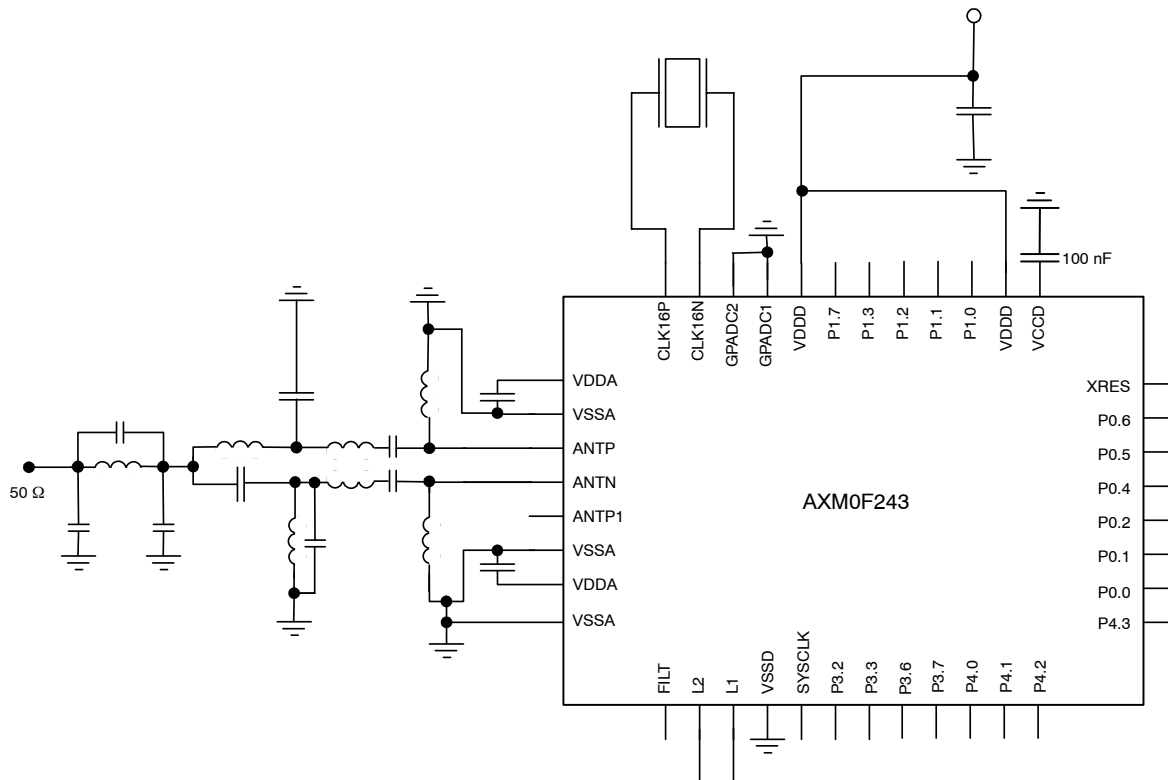

Figure 11. Typical Application Diagram with Single-ended Antenna and Internal TX/RX Switch

AXM0F243

Using an External High-power PA and an External TX/RX Switch

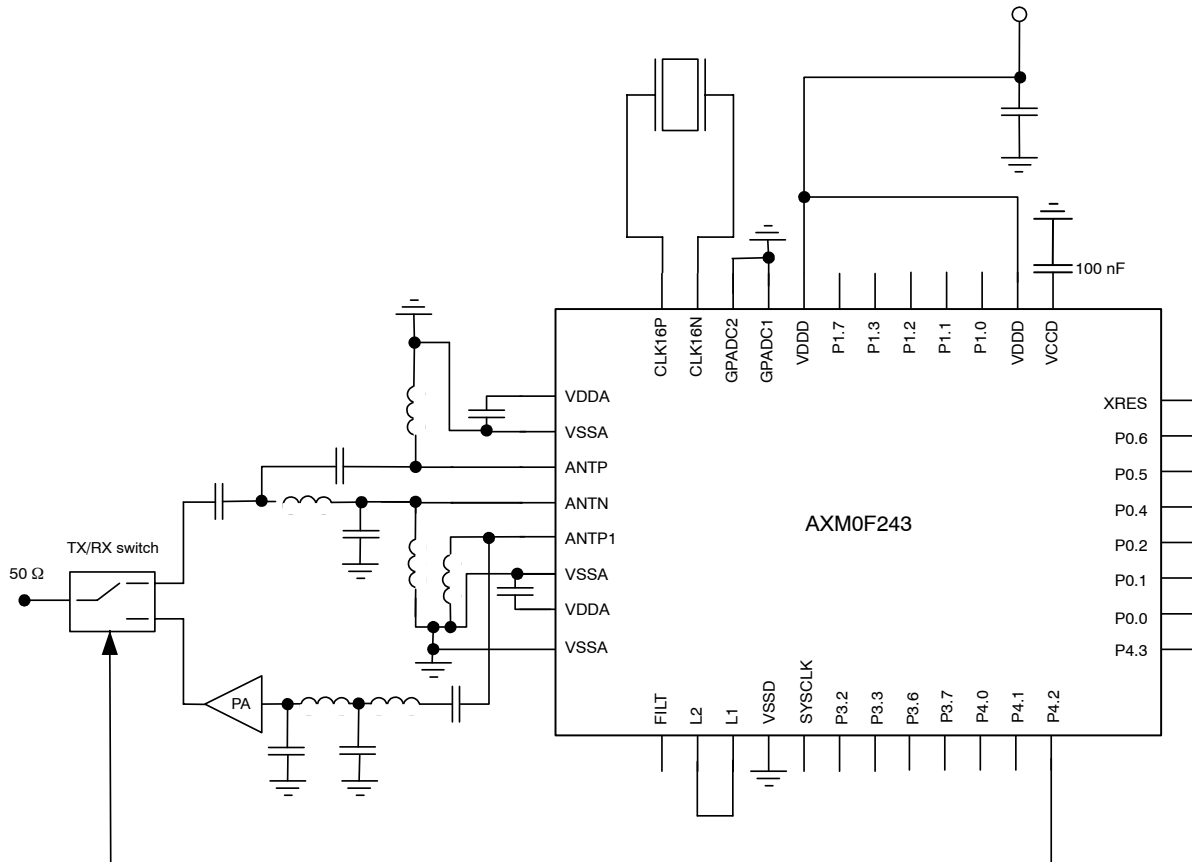

Figure 12. Typical Application Diagram with Single-ended Antenna, External PA and External Antenna Switch

AXM0F243

Using the Single-ended PA

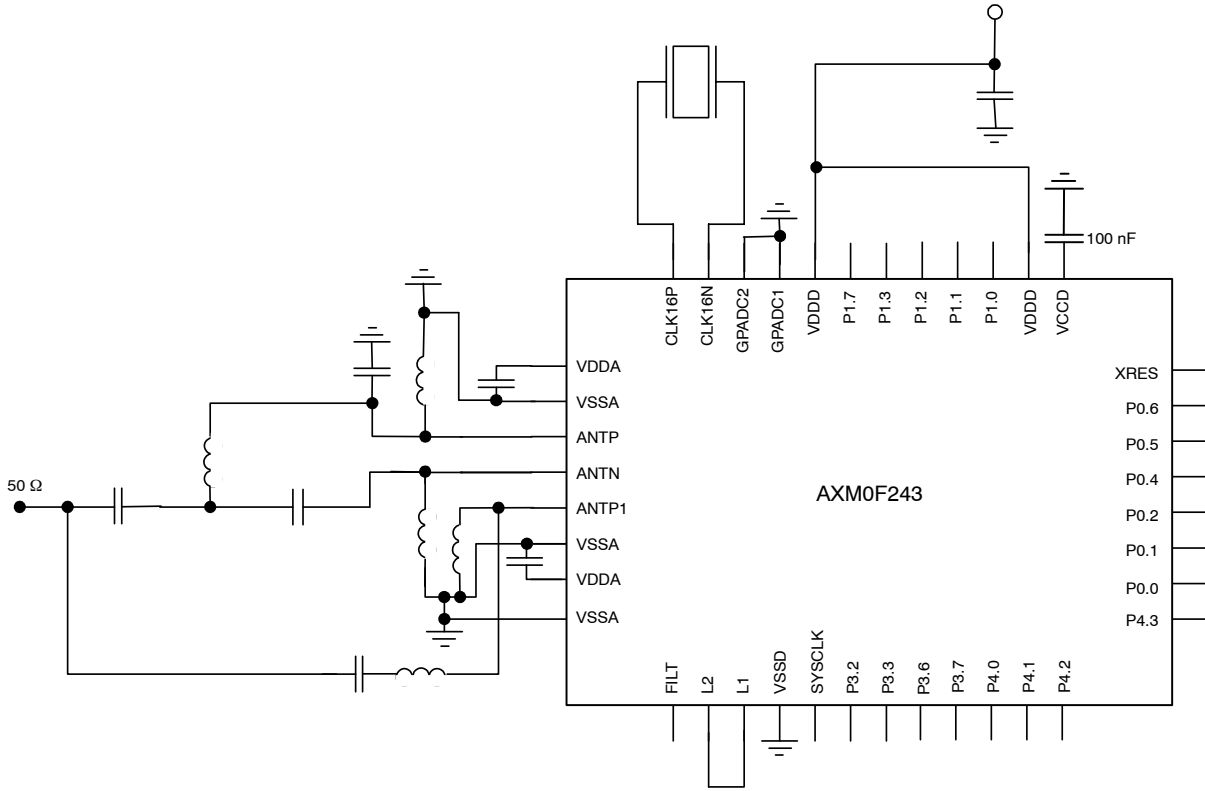

Figure 13. Typical Application Diagram with Single-ended Antenna, Single-ended Internal PA, without RX/TX Switch

AXM0F243

Using Two Antenna

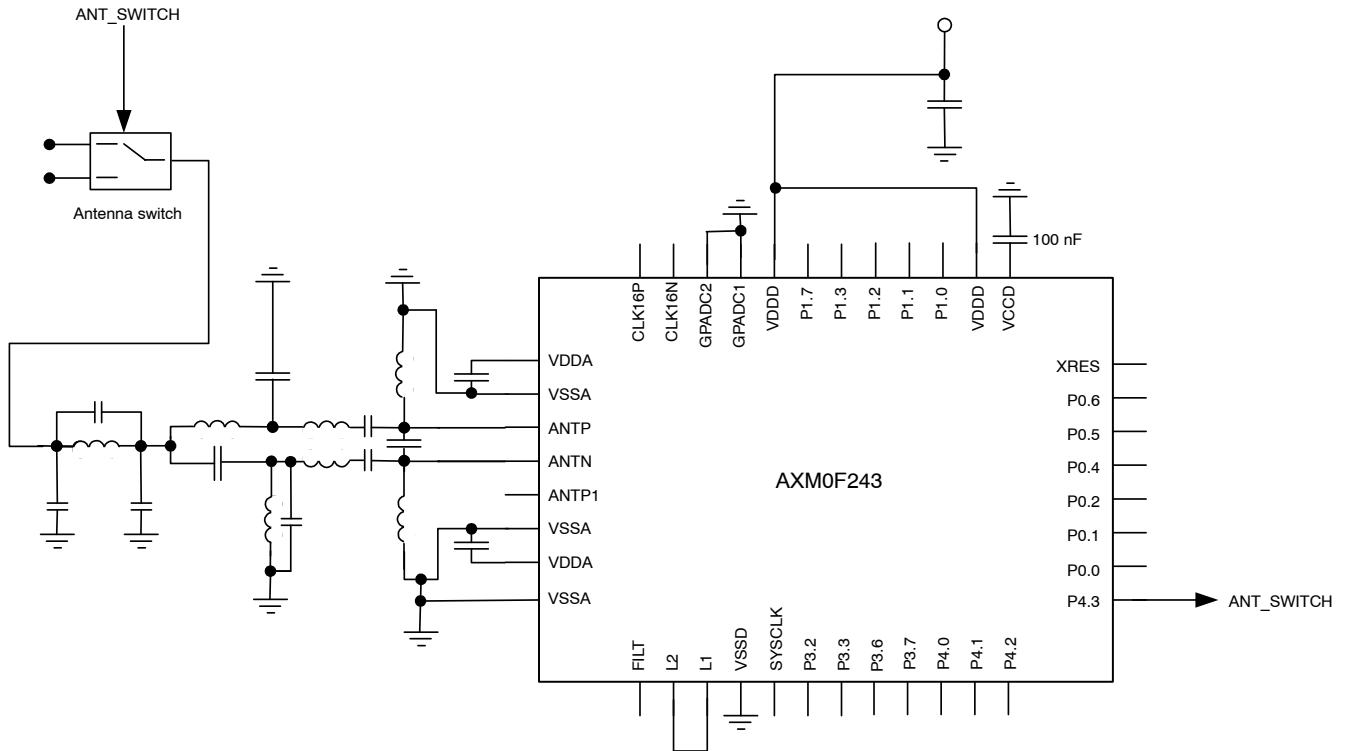

Figure 14. Typical Application Diagram with Two Single-ended Antenna and External Antenna Switch

AXM0F243

Using an External VCO Inductor

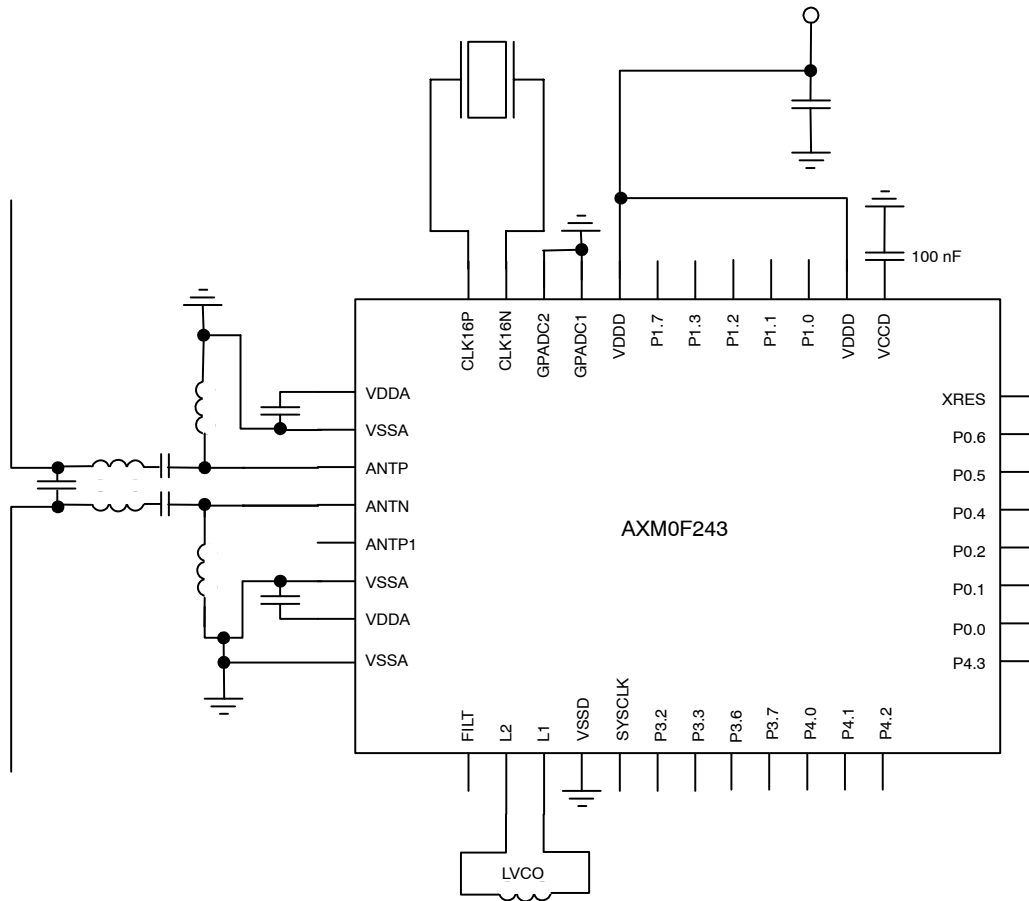

Figure 15. Typical Application Diagram with External VCO Inductor

AXM0F243

Using an External VCO

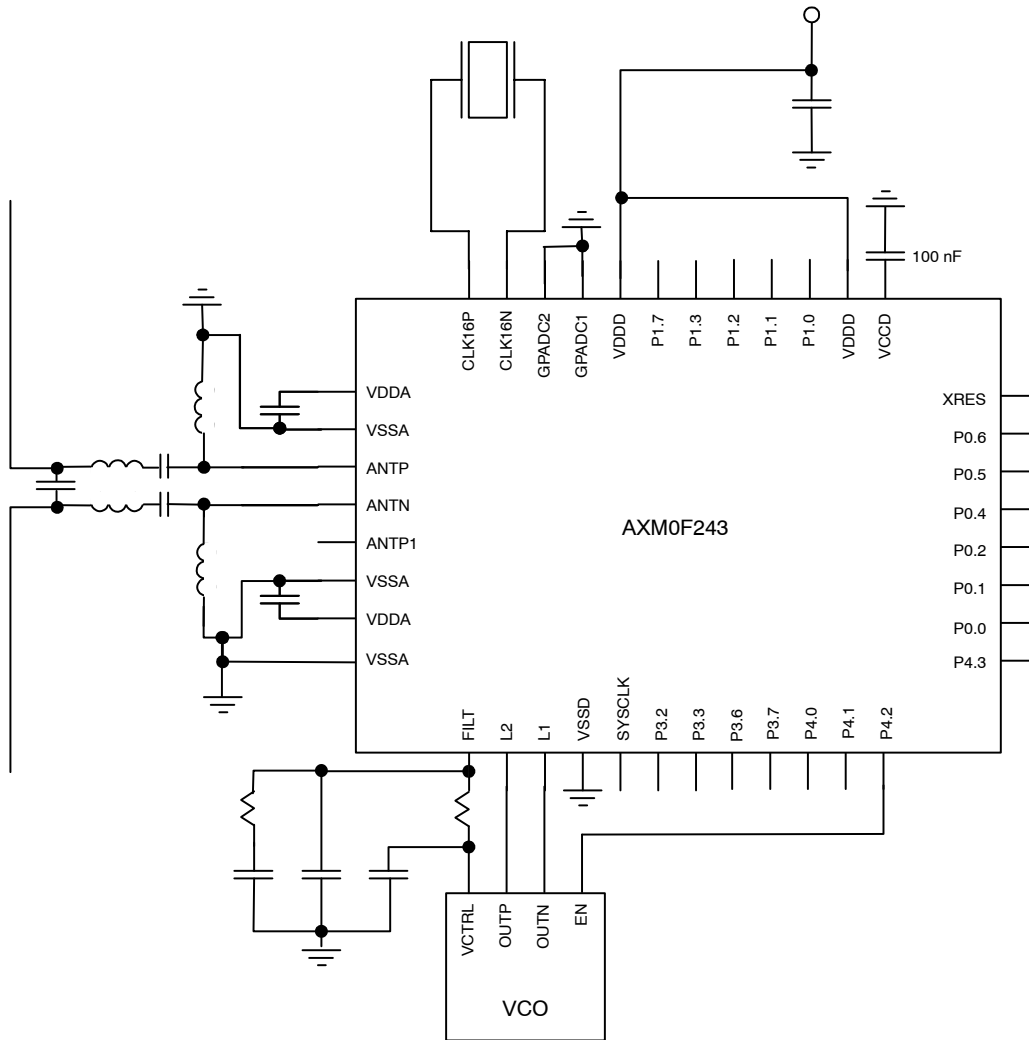

Figure 16. Typical Application Diagram with External VCO

AXM0F243

Using a TCXO

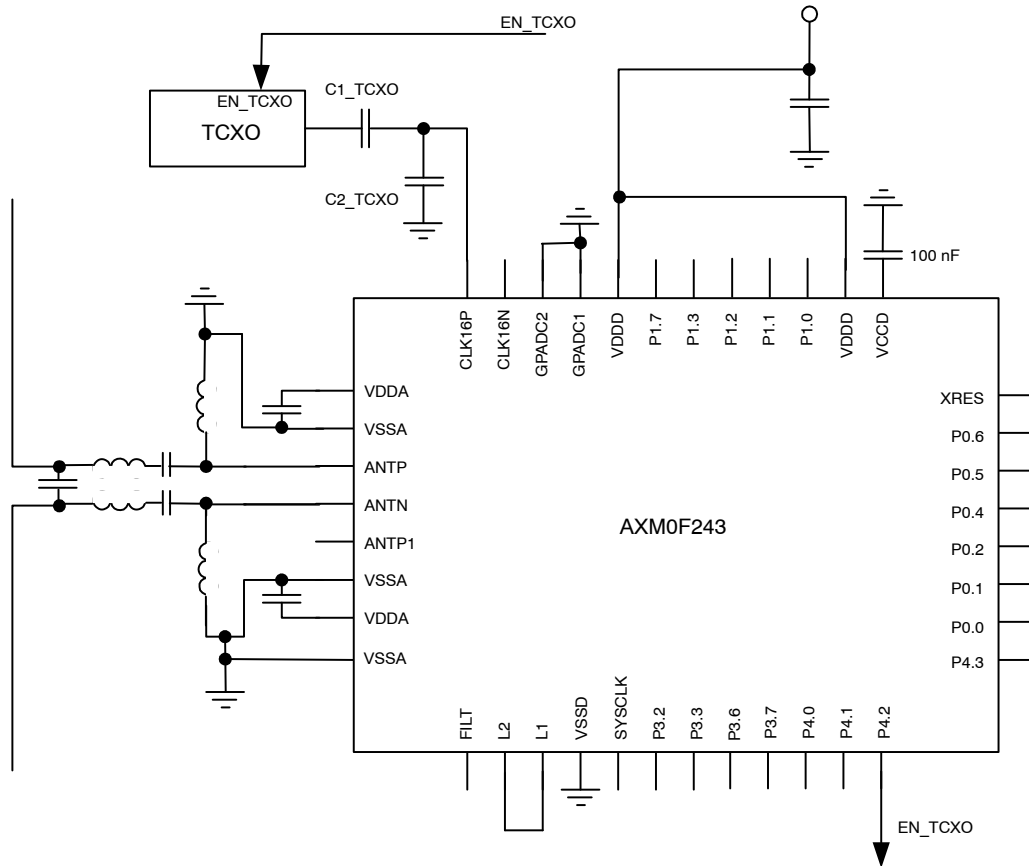

Figure 17. Typical Application Diagram with a TCXO

NOTE: For detailed TCXO network recommendations depending on TCXO output swing refer to the AX5043 Application Note: Use with a TCXO Reference Clock.

QFN40 Soldering Profile

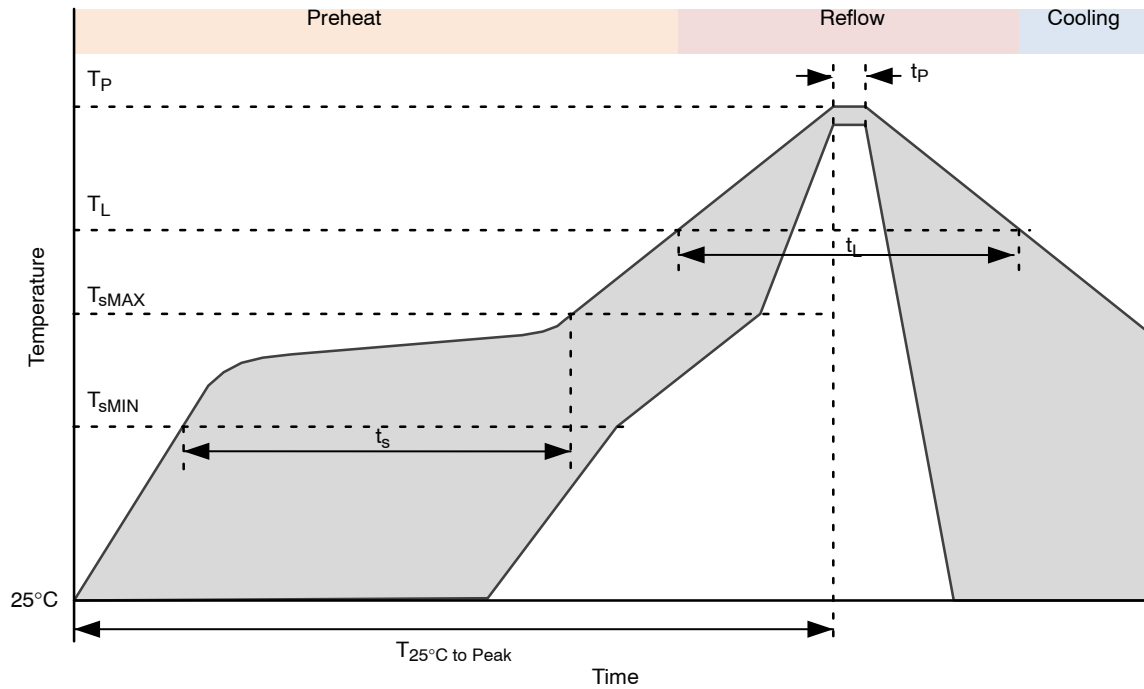

Figure 18. QFN40 Soldering Profile

Table 58.

| Profile Feature | Pb-Free Process |
|--|--|
| Average Ramp-Up Rate | 3°C/s max. |
| Preheat Preheat | |
| Temperature Min | T_{sMIN} 150°C |
| Temperature Max | T_{sMAX} 200°C |
| Time (T_{sMIN} to T_{sMAX}) | t_s 60 – 180 sec |
| Time 25°C to Peak Temperature | $T_{25°C \text{ to Peak}}$ 8 min max. |
| Reflow Phase | |
| Liquidus Temperature | T_L 217°C |
| Time over Liquidus Temperature | t_L 60 – 150 s |
| Peak Temperature | t_p 260°C |
| Time within 5°C of actual Peak Temperature | T_p 20 – 40 s |
| Cooling Phase | |
| Ramp-down rate | 6°C/s max. |

1. All temperatures refer to the top side of the package, measured on the the package body surface.

QFN40 Recommended Pad Layout

1. PCB land and solder masking recommendations are shown in Figure 19.

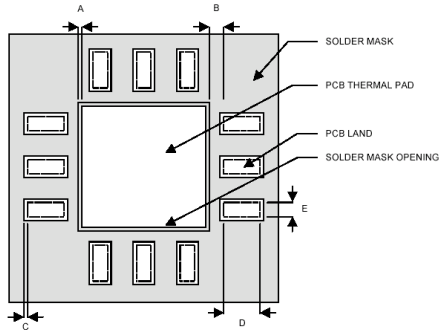

- A = Clearance from PCB thermal pad to solder mask opening, 0.0635 mm minimum
- B = Clearance from edge of PCB thermal pad to PCB land, 0.2 mm minimum
- C = Clearance from PCB land edge to solder mask opening to be as tight as possible to ensure that some solder mask remains between PCB pads.
- D = PCB land length = QFN solder pad length + 0.1 mm
- E = PCB land width = QFN solder pad width + 0.1 mm

Figure 19. PCB Land and Solder Mask Recommendations

2. Thermal vias should be used on the PCB thermal pad (middle ground pad) to improve thermal conductivity from the device to a copper ground plane area on the reverse side of the printed circuit board. The number of vias depends on the package thermal requirements, as determined by thermal simulation or actual testing.
3. Increasing the number of vias through the printed circuit board will improve the thermal conductivity to the reverse side ground plane and external heat sink. In general, adding more metal through the PCB under the IC will improve operational heat transfer, but will require careful attention to uniform heating of the board during assembly.

Assembly Process

Stencil Design & Solder Paste Application

1. Stainless steel stencils are recommended for solder paste application.
2. A stencil thickness of 0.125 – 0.150 mm (5 – 6 mils) is recommended for screening.

3. For the PCB thermal pad, solder paste should be printed on the PCB by designing a stencil with an array of smaller openings that sum to 50% of the QFN exposed pad area. Solder paste should be applied through an array of squares (or circles) as shown in Figure 20.
4. The aperture opening for the signal pads should be between 50–80% of the QFN pad area as shown in Figure 21.
5. Optionally, for better solder paste release, the aperture walls should be trapezoidal and the corners rounded.
6. The fine pitch of the IC leads requires accurate alignment of the stencil and the printed circuit board. The stencil and printed circuit assembly should be aligned to within + 1 mil prior to application of the solder paste.
7. No-clean flux is recommended since flux from underneath the thermal pad will be difficult to clean if water-soluble flux is used.

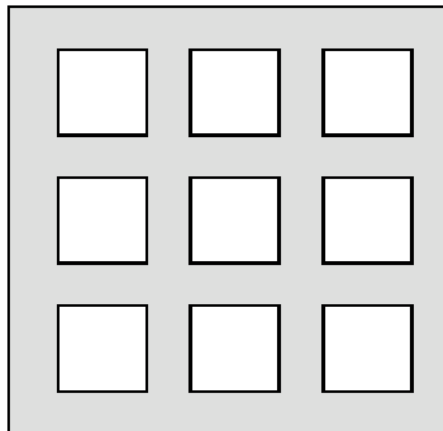
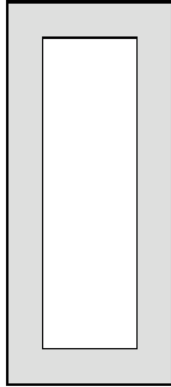

Figure 20. Solder Paste Application on Exposed Pad

AXM0F243

Minimum 50% coverage



62% coverage

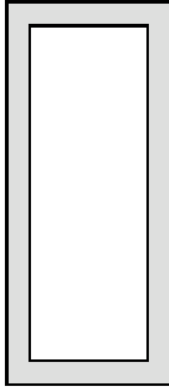

Maximum 80% coverage

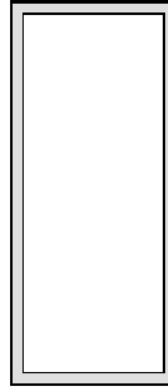
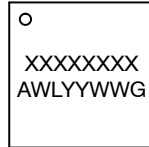

Figure 21. Solder Paste Application on Pins

MARKING DIAGRAM



XXX = Specific Device Code
 A = Assembly Location
 WL = Wafer Lot
 YY = Year
 WW = Work Week
 G = Pb-Free Package

Table 59. ORDERING INFORMATION

| Device | Package | OPN | Shipping [†] |
|------------|---------------------------------|-----------------|-----------------------|
| AXM0F243-1 | QFN40 (Pb-Free, Halide Free) | AXM0F243-1-TX40 | 4000 / Tape & Reel |

[†]For information on tape and reel specifications, including part orientation and tape sizes, please refer to our Tape and Reel Packaging Specification Brochure, BRD8011/D.

AXM0F243

PACKAGE DIMENSIONS

QFN40 7x5, 0.5P
CASE 485EG
ISSUE B

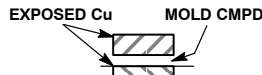
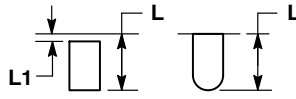
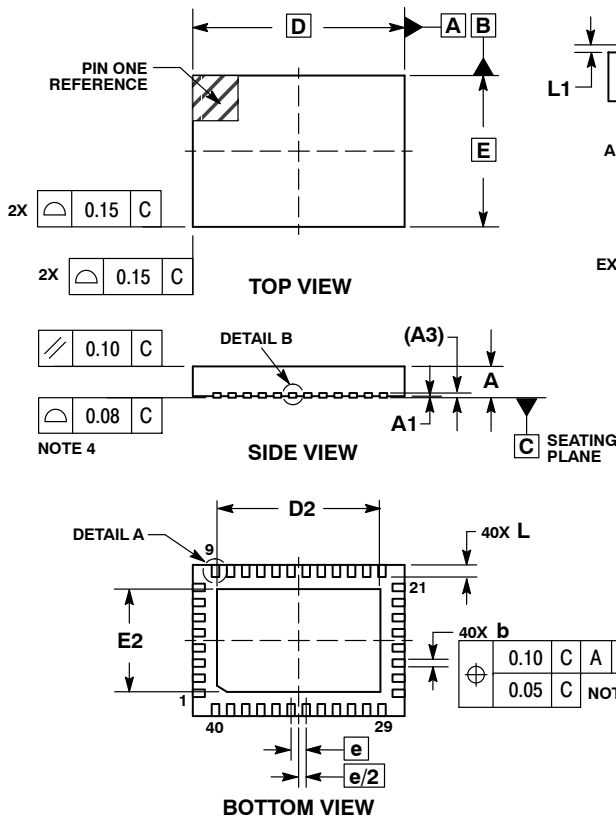

NOTES:

1. DIMENSIONING AND TOLERANCING PER ASME Y14.5M, 1994.
2. CONTROLLING DIMENSIONS: MILLIMETERS.
3. DIMENSION b APPLIES TO PLATED TERMINAL AND IS MEASURED BETWEEN 0.25 AND 0.30mm FROM TERMINAL
4. COPLANARITY APPLIES TO THE EXPOSED PAD AS WELL AS THE TERMINALS.

| DIM | MILLIMETERS | |
|-----|-------------|------|
| | MIN | MAX |
| A | 0.80 | 1.00 |
| A1 | 0.00 | 0.05 |
| A3 | 0.20 REF | |
| b | 0.18 | 0.30 |
| D | 7.00 BSC | |
| D2 | 5.30 | 5.50 |
| E | 5.00 BSC | |
| E2 | 3.30 | 3.50 |
| e | 0.50 BSC | |
| L | 0.30 | 0.50 |
| L1 | --- | 0.15 |

RECOMMENDED SOLDERING FOOTPRINT*

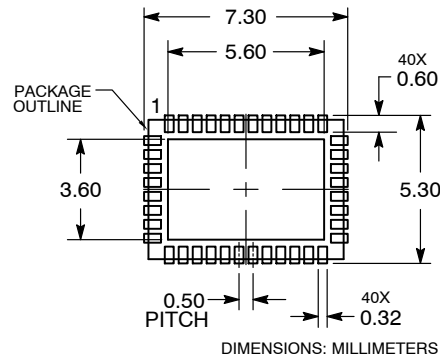

*For additional information on our Pb-Free strategy and soldering details, please download the ON Semiconductor Soldering and Mounting Techniques Reference Manual, SOLDERRM/D.

Arm and Cortex are registered trademarks of Arm Limited (or its subsidiaries) in the US and/or elsewhere.

Portions Copyright 2018 Cypress Semiconductor Corporation, used with permission, all other Cypress Semiconductor Corporation rights reserved.

ON Semiconductor and are trademarks of Semiconductor Components Industries, LLC dba ON Semiconductor or its subsidiaries in the United States and/or other countries. ON Semiconductor owns the rights to a number of patents, trademarks, copyrights, trade secrets, and other intellectual property. A listing of ON Semiconductor's product/patent coverage may be accessed at www.onsemi.com/site/pdf/Patent-Marking.pdf. ON Semiconductor reserves the right to make changes without further notice to any products herein. ON Semiconductor makes no warranty, representation or guarantee regarding the suitability of its products for any particular purpose, nor does ON Semiconductor assume any liability arising out of the application or use of any product or circuit, and specifically disclaims any and all liability, including without limitation special, consequential or incidental damages. Buyer is responsible for its products and applications using ON Semiconductor products, including compliance with all laws, regulations and safety requirements or standards, regardless of any support or applications information provided by ON Semiconductor. "Typical" parameters which may be provided in ON Semiconductor data sheets and/or specifications can and do vary in different applications and actual performance may vary over time. All operating parameters, including "Typicals" must be validated for each customer application by customer's technical experts. ON Semiconductor does not convey any license under its patent rights nor the rights of others. ON Semiconductor products are not designed, intended, or authorized for use as a critical component in life support systems or any FDA Class 3 medical devices or medical devices with a same or similar classification in a foreign jurisdiction or any devices intended for implantation in the human body. Should Buyer purchase or use ON Semiconductor products for any such unintended or unauthorized application, Buyer shall indemnify and hold ON Semiconductor and its officers, employees, subsidiaries, affiliates, and distributors harmless against all claims, costs, damages, and expenses, and reasonable attorney fees arising out of, directly or indirectly, any claim of personal injury or death associated with such unintended or unauthorized use, even if such claim alleges that ON Semiconductor was negligent regarding the design or manufacture of the part. ON Semiconductor is an Equal Opportunity/Affirmative Action Employer. This literature is subject to all applicable copyright laws and is not for resale in any manner.

PUBLICATION ORDERING INFORMATION

LITERATURE FULFILLMENT:
Email Requests to: orderlit@onsemi.com

TECHNICAL SUPPORT
North American Technical Support:
Voice Mail: 1 800-282-9855 Toll Free USA/Canada
Phone: 011 421 33 790 2910

Europe, Middle East and Africa Technical Support:
Phone: 00421 33 790 2910
For additional information, please contact your local Sales Representative

Компания «Океан Электроники» предлагает заключение долгосрочных отношений при поставках импортных электронных компонентов на взаимовыгодных условиях!

Наши преимущества:

- Поставка оригинальных импортных электронных компонентов напрямую с производств Америки, Европы и Азии, а так же с крупнейших складов мира;
- Широкая линейка поставок активных и пассивных импортных электронных компонентов (более 30 млн. наименований);
- Поставка сложных, дефицитных, либо снятых с производства позиций;
- Оперативные сроки поставки под заказ (от 5 рабочих дней);
- Экспресс доставка в любую точку России;
- Помощь Конструкторского Отдела и консультации квалифицированных инженеров;
- Техническая поддержка проекта, помощь в подборе аналогов, поставка прототипов;
- Поставка электронных компонентов под контролем ВП;
- Система менеджмента качества сертифицирована по Международному стандарту ISO 9001;
- При необходимости вся продукция военного и аэрокосмического назначения проходит испытания и сертификацию в лаборатории (по согласованию с заказчиком);
- Поставка специализированных компонентов военного и аэрокосмического уровня качества (Xilinx, Altera, Analog Devices, Intersil, Interpoint, Microsemi, Actel, Aeroflex, Peregrine, VPT, Syfer, Eurofarad, Texas Instruments, MS Kennedy, Miteq, Cobham, E2V, MA-COM, Hittite, Mini-Circuits, General Dynamics и др.);

Компания «Океан Электроники» является официальным дистрибьютором и эксклюзивным представителем в России одного из крупнейших производителей разъемов военного и аэрокосмического назначения «JONHON», а так же официальным дистрибьютором и эксклюзивным представителем в России производителя высокотехнологичных и надежных решений для передачи СВЧ сигналов «FORSTAR».



JONHON

«JONHON» (основан в 1970 г.)

Разъемы специального, военного и аэрокосмического назначения:

(Применяются в военной, авиационной, аэрокосмической, морской, железнодорожной, горно- и нефтедобывающей отраслях промышленности)

«FORSTAR» (основан в 1998 г.)

ВЧ соединители, коаксиальные кабели,
кабельные сборки и микроволновые компоненты:

(Применяются в телекоммуникациях гражданского и специального назначения, в средствах связи, РЛС, а так же военной, авиационной и аэрокосмической отраслях промышленности).



Телефон: 8 (812) 309-75-97 (многоканальный)

Факс: 8 (812) 320-03-32

Электронная почта: ocean@oceanchips.ru

Web: <http://oceanchips.ru/>

Адрес: 198099, г. Санкт-Петербург, ул. Калинина, д. 2, корп. 4, лит. А