

Fully Sealed Potentiometer Cermet or Conductive Plastic

FEATURES

- PRV6S high power rating 1.5 W at 70 °C (cermet)
- PRV6A 0.75 W at 70 °C (conductive plastic)
- Tests according to CECC 41000 or IEC 60393-1
- Low cost
- Fully sealed and panel sealed
- Compatible RV6 (MIL R 94)
- Mechanical endurance 50 000 cycles
- Material categorization: for definitions of compliance please see www.vishay.com/doc?99912

**RoHS
COMPLIANT**
DESIGN SUPPORT TOOLS AVAILABLE

QUICK REFERENCE DATA	
Multiple module	No
Switch module	n/a
Detent module	n/a
Special electrical laws	A: linear, L: logarithmic, F: reverse logarithmic
Sealing level	IP 67
Lifespan	50K cycles

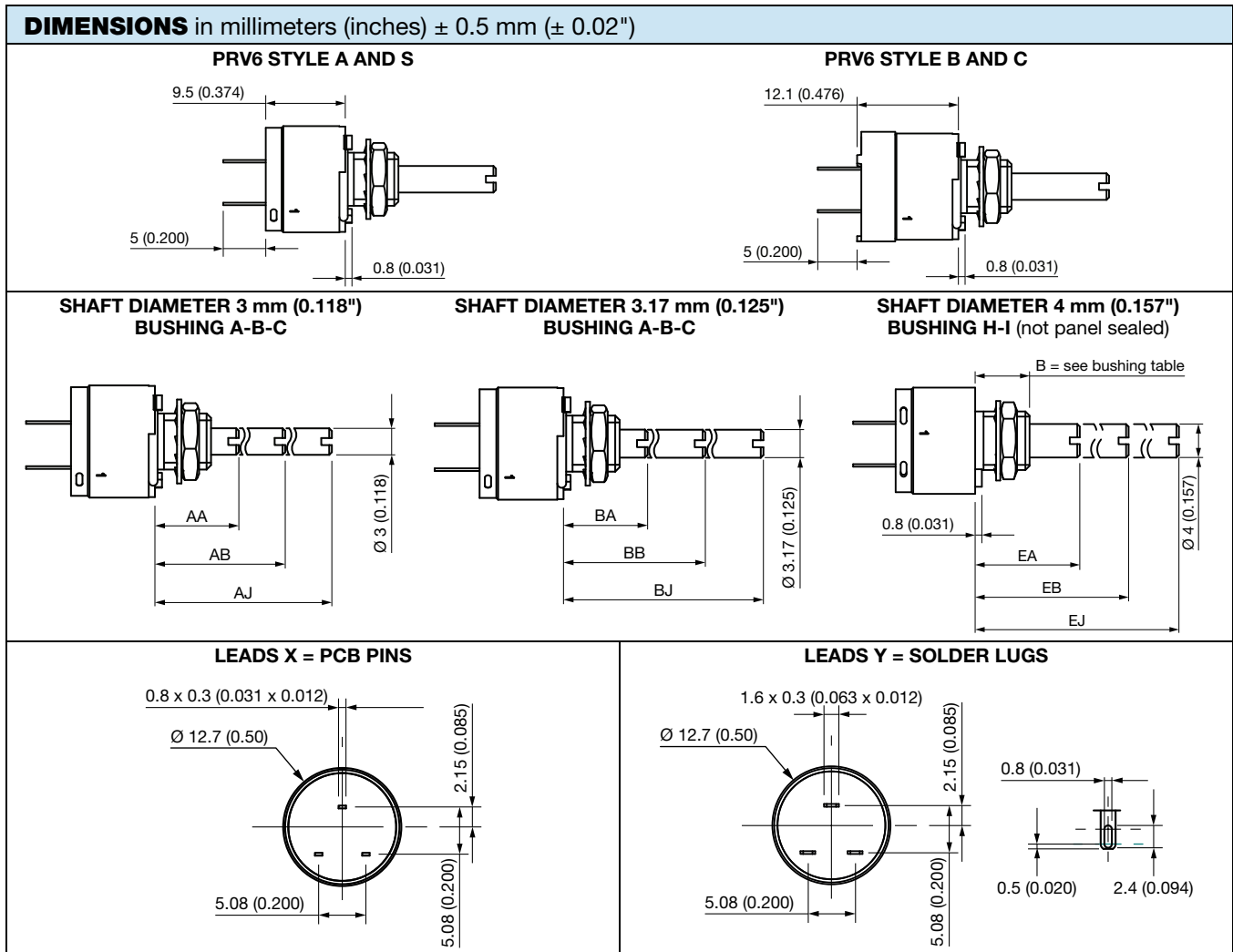

ELECTRICAL SPECIFICATIONS		
	PRV6S, PRV6B	PRV6A, PRV6C
Resistive element	cermet	conductive plastic
Electrical travel	270° ± 15°	
Resistance range	linear taper (A)	20 Ω to 10 MΩ
	non-linear taper (F-L)	470 Ω to 1 MΩ
		1 kΩ to 1 MΩ
		470 Ω to 500 kΩ (± 20 %)
Taper		
Tolerance	standard	± 20 %
	on request	± 10 %, ± 5 %
		± 20 %
		± 10 % (1 kΩ to 100 kΩ)
Circuit diagram		
Power rating at 70 °C	linear	1.5 W at 70 °C
	other tapers	0.75 W
		0.75 W at 70 °C
		0.4 W
Power rating chart		
Temperature coefficient (typical)	± 150 ppm/°C	± 500 ppm/°C
Limiting element voltage	350 V	
Contact resistance variation (CRV)	2 % or 3 Ω	
End resistance (typical)	1 Ω	
Dielectric strength (RMS)	1750 V _{RMS}	
Insulation resistance (500 V_{DC})	10 ⁶ MΩ	



MECHANICAL SPECIFICATIONS	
Mechanical travel	300° ± 5°
Operating torque (Ncm (oz.in.))	0.5 to 2 (0.7 to 3)
End stop torque (max. Ncm (lb.in.))	35 (3)
Tightening torque (max. Ncm (lb.in.))	150 (13)

ENVIRONMENTAL SPECIFICATIONS		
	PRV6S, PRV6B	PRV6A, PRV6C
Temperature range	-55 °C to +125 °C	-40 °C to +125 °C
Climatic category	55/125/56	40/125/56
Sealing	Fully sealed container; IP67 and panel sealed	

PERFORMANCES				
TESTS	CONDITIONS	TYPICAL VALUES AND DRIFTS		
		$\Delta R_T/R_T$ (%)	$\Delta R_{1-2}/R_{1-2}$ (%)	OTHER
Electrical endurance	1000 h at rated power 90°/30° - temperature 70 °C	± 1 %		CRV < 3 % Rn
Climatic sequence	Phase A dry heat 100 °C Phase B damp heat Phase C cold -55 °C Phase D damp heat 5 cycles	± 0.5 %	± 1 %	
Damp heat, steady state	56 days	± 0.5 %	± 1 %	Insulation resistance: > 10 ⁴ MΩ
Change of temperature	5 cycles, -55 °C to +125 °C	± 0.5 %		
Mechanical endurance	50 000 cycles	± 3 %		CRV < 2 % Rn
Shock	50 g at 11 ms 3 successive shocks in 3 directions	± 0.1 %	± 0.2 %	
Vibration	10 Hz to 55 Hz 0.75 mm or 10 g during 6 h	± 0.1 %	± 0.2 %	

Note

- Nothing stated herein shall be construed as a guarantee of quality or durability

STANDARD RESISTANCE ELEMENT DATA						
STANDARD RESISTANCE VALUES	PRV6S AND PRV6B WITH LINEAR TAPER			PRV6S AND PRV6B WITH NON-LINEAR TAPER		
	MAX. POWER AT 70 °C	MAX. WORKING VOLTAGE	MAX. WIPER CURRENT	MAX. POWER AT 70 °C	MAX. WORKING VOLTAGE	MAX. WIPER CURRENT
Ω	W	V	mA	W	V	mA
20	1.5	5.48	274			
50	1.5	8.66	173			
100	1.5	12.2	122			
200	1.5	17.3	87			
500	1.5	27.4	55	0.75	19.4	39
1K	1.5	38.7	38.7	0.75	27.3	27.4
2K	1.5	54.8	27.4	0.75	38.2	19.3
5K	1.5	86.6	17.3	0.75	61.2	12.2
10K	1.5	122.5	12.2	0.75	87	8.7
20K	1.5	173	8.26	0.75	122	6.1
50K	1.5	274	5.65	0.75	194	3.9
100K	1.22	350	3.5	0.75	273	2.74
220K	0.61	350	1.75	0.61	350	1.75
500K	0.25	350	0.70	0.25	350	0.7
1M	0.12	350	0.35	0.12	350	0.35
2M	0.06	350	0.17			
5M	0.025	350	0.070			
10M	0.012	350	0.035			

MARKING
<ul style="list-style-type: none"> • Vishay trademark • Part number • Manufacturing date code • Terminal: 1

PACKAGING
<ul style="list-style-type: none"> • Box of 15, 20, 25, or 50 pieces, code B12, B15, B17, or B25, depending of body and shaft construction

OPTIONS	
SPECIAL FEATURES	
Panel sealing	Except for dia. 4 mm shaft, an O.ring is supplied with the potentiometer. This O.ring should be placed into the groove of the body and ensures the panel sealing. For dia. 4 mm shaft please see note "P" in ordering information.
Shaft locking	<div style="display: flex; justify-content: space-around;"> <div style="text-align: center;"> <p>Bushing E</p> </div> <div style="text-align: center;"> <p>Bushing D</p> </div> </div> <div style="display: flex; justify-content: space-around; margin-top: 20px;"> <div style="text-align: center;"> <p>Bushing S no panel sealed (61QH)</p> </div> <div style="text-align: center;"> <p>Bushing S panel sealed (61QPH)</p> </div> </div>
Shafts	Shaft lengths are measured from the mounting face to the free end of the shaft. Special shafts are available if the customer supplies a drawing. The shaft slot is aligned to the wiper within $\pm 10^\circ$.
Hardware	Nuts, washer and O.ring are separately supplied (not mounted on the potentiometer), in a small bag placed in the packaging.
Locating peg	<p>Except for dia. 4 mm shaft, the potentiometers are delivered with 2 opposite locating pegs orientated at 45°. These 2 pegs can be easily broken-off by the customer. On request, the orientation of the pegs can be at 30° instead of 45°.</p> <div style="display: flex; justify-content: space-around;"> <div style="text-align: center;"> <p>Locating Peg A Bushing: A-B-C-D-E</p> </div> <div style="text-align: center;"> <p>Locating Peg R Bushing: H-I-S (locking shaft, not panel sealed)</p> </div> </div> <div style="display: flex; justify-content: space-around; margin-top: 20px;"> <div style="text-align: center;"> <p>Locating Peg L Bushing: A-B-C-D-E</p> </div> <div style="text-align: center;"> <p>Without Locating Peg Panel sealed bushing:</p> </div> </div>



LOCATING PEG CODE					
BUSHING	OLD CODE	A	L	R	O
A	6	x	x		x ⁽¹⁾
B	61	x	x		x ⁽¹⁾
C	62	x	x		x ⁽¹⁾
D	61H	x	x		x ⁽¹⁾
E	62H	x	x		x ⁽¹⁾
H	6Q			x	
I	61Q			x	
J	6QP				x
K	61QP				x
S	61QH			x	
S	61QPH				x

Note

⁽¹⁾ Not standard, special manufacturing

ORDERING INFORMATION (part number)																	
P	R	V	6	B	B	A	B	G	X	B	1	7	5	0	2	M	A
MODEL	STYLE	BUSHING			LOCATING PEG	SHAFT			LEADS	PACKAGING	RESISTANCE CODE/TOLERANCE/TAPER OR SPECIAL						
PRV6	S = standard A = audio B = body length C = audio and body length	∅	L	Old codes	0 = without A = 45° L = 30° R = 180° round (see locating peg table above)	∅	L	Old codes	X = PCB pins (old code W) Y = solder lugs	Depending of body and shaft construction: B12 = box 15 pcs B15 = box 20 pcs B17 = box 25 pcs B25 = box 50 pcs	Resistance: from 200 = 20 Ω to 106 = 10 MΩ for linear cermet Tolerance: standard M = 20 % on request K = 10 % or J = 5 % Taper: A, L, F or special code given by Vishay						
		A	1/4	1/4	6	AA	3	9.5	K								
		B	1/4	3/8	61	AB	3	12.5	M								
		C	1/4	1/2	62	AJ	3	22	R								
		D	1/4	3/8	61H	BA	1/8	9.5	CK								
		E	1/4	1/2	62H	BB	1/8	12.5	CM								
		H	7	6.5	6Q	BG	1/8	16	CD								
		I	7	9.5	61Q	BJ	1/8	22	CR								
		J	7	6.5	6QP	EA	4	9.5	E								
		K	7	9.5	61QP	EB	4	12.5	F								
		S	7	9.5	61QH	EJ	4	22	G								
		S	7	9.5	61QPH	AP	custom shaft										
						all are slotted											

PART NUMBER DESCRIPTION (for information only using old codes)													
PRV	S	61	W	CD	5K	20 %	A		BO				e3
MODEL	BUSHING	LEADS	SPECIAL	SHAFT	VALUE	TOLERANCE	TAPER	SPECIAL	PACKAGING	SPECIAL	AP N°	SPECIAL	LEAD FINISH

RELATED DOCUMENTS	
APPLICATION NOTES	
Potentiometers and Trimmers	www.vishay.com/doc?51001
Guidelines for Vishay Sfernice Resistive and Inductive Components	www.vishay.com/doc?52029



Disclaimer

ALL PRODUCT, PRODUCT SPECIFICATIONS AND DATA ARE SUBJECT TO CHANGE WITHOUT NOTICE TO IMPROVE RELIABILITY, FUNCTION OR DESIGN OR OTHERWISE.

Vishay Intertechnology, Inc., its affiliates, agents, and employees, and all persons acting on its or their behalf (collectively, "Vishay"), disclaim any and all liability for any errors, inaccuracies or incompleteness contained in any datasheet or in any other disclosure relating to any product.

Vishay makes no warranty, representation or guarantee regarding the suitability of the products for any particular purpose or the continuing production of any product. To the maximum extent permitted by applicable law, Vishay disclaims (i) any and all liability arising out of the application or use of any product, (ii) any and all liability, including without limitation special, consequential or incidental damages, and (iii) any and all implied warranties, including warranties of fitness for particular purpose, non-infringement and merchantability.

Statements regarding the suitability of products for certain types of applications are based on Vishay's knowledge of typical requirements that are often placed on Vishay products in generic applications. Such statements are not binding statements about the suitability of products for a particular application. It is the customer's responsibility to validate that a particular product with the properties described in the product specification is suitable for use in a particular application. Parameters provided in datasheets and / or specifications may vary in different applications and performance may vary over time. All operating parameters, including typical parameters, must be validated for each customer application by the customer's technical experts. Product specifications do not expand or otherwise modify Vishay's terms and conditions of purchase, including but not limited to the warranty expressed therein.

Except as expressly indicated in writing, Vishay products are not designed for use in medical, life-saving, or life-sustaining applications or for any other application in which the failure of the Vishay product could result in personal injury or death. Customers using or selling Vishay products not expressly indicated for use in such applications do so at their own risk. Please contact authorized Vishay personnel to obtain written terms and conditions regarding products designed for such applications.

No license, express or implied, by estoppel or otherwise, to any intellectual property rights is granted by this document or by any conduct of Vishay. Product names and markings noted herein may be trademarks of their respective owners.

Компания «Океан Электроники» предлагает заключение долгосрочных отношений при поставках импортных электронных компонентов на взаимовыгодных условиях!

Наши преимущества:

- Поставка оригинальных импортных электронных компонентов напрямую с производств Америки, Европы и Азии, а так же с крупнейших складов мира;
- Широкая линейка поставок активных и пассивных импортных электронных компонентов (более 30 млн. наименований);
- Поставка сложных, дефицитных, либо снятых с производства позиций;
- Оперативные сроки поставки под заказ (от 5 рабочих дней);
- Экспресс доставка в любую точку России;
- Помощь Конструкторского Отдела и консультации квалифицированных инженеров;
- Техническая поддержка проекта, помощь в подборе аналогов, поставка прототипов;
- Поставка электронных компонентов под контролем ВП;
- Система менеджмента качества сертифицирована по Международному стандарту ISO 9001;
- При необходимости вся продукция военного и аэрокосмического назначения проходит испытания и сертификацию в лаборатории (по согласованию с заказчиком);
- Поставка специализированных компонентов военного и аэрокосмического уровня качества (Xilinx, Altera, Analog Devices, Intersil, Interpoint, Microsemi, Actel, Aeroflex, Peregrine, VPT, Syfer, Eurofarad, Texas Instruments, MS Kennedy, Miteq, Cobham, E2V, MA-COM, Hittite, Mini-Circuits, General Dynamics и др.);

Компания «Океан Электроники» является официальным дистрибьютором и эксклюзивным представителем в России одного из крупнейших производителей разъемов военного и аэрокосмического назначения «JONHON», а так же официальным дистрибьютором и эксклюзивным представителем в России производителя высокотехнологичных и надежных решений для передачи СВЧ сигналов «FORSTAR».



JONHON

«JONHON» (основан в 1970 г.)

Разъемы специального, военного и аэрокосмического назначения:

(Применяются в военной, авиационной, аэрокосмической, морской, железнодорожной, горно- и нефтедобывающей отраслях промышленности)

«FORSTAR» (основан в 1998 г.)

ВЧ соединители, коаксиальные кабели,
кабельные сборки и микроволновые компоненты:

(Применяются в телекоммуникациях гражданского и специального назначения, в средствах связи, РЛС, а так же военной, авиационной и аэрокосмической отраслях промышленности).



Телефон: 8 (812) 309-75-97 (многоканальный)

Факс: 8 (812) 320-03-32

Электронная почта: ocean@oceanchips.ru

Web: <http://oceanchips.ru/>

Адрес: 198099, г. Санкт-Петербург, ул. Калинина, д. 2, корп. 4, лит. А