

NCP6361EVB

NCP6361 WLCSP9 Evaluation Board User's Manual



ON Semiconductor®

<http://onsemi.com>

EVAL BOARD USER'S MANUAL

Introduction

This document gives a detailed description of the NCP6361 Evaluation Board (WLCSP9) with the Bill Of Material (BOM), board schematic and layout. The appropriate laboratory test setups are also provided. The NCP6361 Evaluation Board has been designed to help for a quick evaluation of the NCP6361 buck converter.

This document has to be used together with the NCP6361 datasheet. The datasheet contains full technical details regarding the NCP6361 specifications and operation. The board (FR4 material) is implemented in 4 metal layers. The top and bottom layers have thicknesses of 35 μm (1 oz). The PCB thickness is 1.6 mm with dimensions of 77 mm by 55 mm (see Figure 1).



Figure 1. Evaluation Board Picture

EQUIPMENT

Table 1. RECOMMENDED EXAMPLE OF EQUIPMENT

Description	Main Features	Example of Equipment (Note 1)	Qty.
Regulated Power Supply	1.5 A DC Current capability	Tektronix PS2520G G ^W INSTEK PPT3615	1
Multimeter		Keitley 2000 or 2001	2
Sourcemeater	3 A DC Current capability	Keitley 2420	2
Oscilloscope	500 MHz Bandwidth, four channel scope, min 1 Mbit memory per channel (Note 2)	Tecktronix TDS744, 754 or 784 / TDS5054 series or Lecroy WR5060 TDS5104B, 1 GHz, 5 GS/s	1
Voltage probe	3 probes 500 MHz Bandwidth	Tektronix P6139A / P5050	3
Current probe	1 probe	Tektronix TCP 202	
Waveform generator	Arbitrary/Fonction generator	Tektronix AFG 3102 Dual channel, 100 MHz	1
SMB Cable		VCON	1

1. Equipment used in the context of this Evaluation Board User's Manual
2. Greater Scope memory per channel offers better resolution

NCP6361EVb

QUICK TEST PROCEDURE

(see Figure 2)

Initial Setup:

The initial setup given here is recommended before starting measurements on the evaluation board.

- Jumper Configuration: initial / default setup
 - ◆ LTR1 not connected
 - ◆ LTR2 connected – Can be used for visualizing the current in the inductor (ILX) using an oscilloscope current probe
 - ◆ LTR3 connected – Connect FB pin to Vout

- ◆ S1: Enable pin; default with jumper connected to VBAT (Logic Level High), device is activated by default
- ◆ S2: ByPass Enable option, default with jumper connected to GND (Logic Level Low), By Pass not activated
- ◆ S3: Frequency Selection pin, default with jumper connected to GND (Logic level Low), FSEL = 0 \Leftrightarrow Frequency = 6 MHz selected

Table 2. SWITCHING FREQUENCY SELECTION

FSEL	Buck Converter Switching Frequency (F _{SW})	Inductor (LX)
0	6 MHz (24 MHz / 4)	0.47 μ H
1	3.429 MHz (24 MHz / 7)	1 μ H

- Connect Vin (VBAT) with VBAT tuned at 3.7 V for example
- Connect VCON with VCON tuned at 0.8 V for example \Rightarrow Vout = 0.8V x 2.5 = 2V
- Connect load (8 Ω or 10 Ω respectively 250 mA or 200 mA considering Vout = 2 V) or connect a current source tuned with 100 mA (as initial load value)
- Connect voltage probe or multi-meter on Vout test point
- Other test points can be eventually checked: VCON (TP9), FB, VBAT, EN, FSEL and BPEN
- SW test point is available as well
- Apply VBAT = 3.7 V first then VCON = 0.8 V and finally IOU (100 mA) if current source connected
- Check Vout = 2 V
- VBAT can vary from 2.5 V to 5.5 V according to datasheet

- VCON can vary from 0.16 V to 1.4 V with a corresponding respective Vout of 0.4 V typical and 3.5 V typical
- Output current can vary from 0 to 800 mA in PWM mode and up to 1.2 A in By Pass mode

Operating Modes:

- 4 operating modes are available: they can be checked by sweeping VCON according to datasheet specification and below rough guide lines:
 - ◆ Sleep Mode with VCON below about 0.125 V
 - ◆ PFM Mode with VCON above 0.125 V
 - ◆ PWM Mode when Iout above about 200 mA
 - ◆ By Pass Mode when Vout close to Vin such as Vin – Vout below about 200 mV or by forcing bypass mode with pin BPEN

NCP6361EVB

BOARD DESCRIPTION

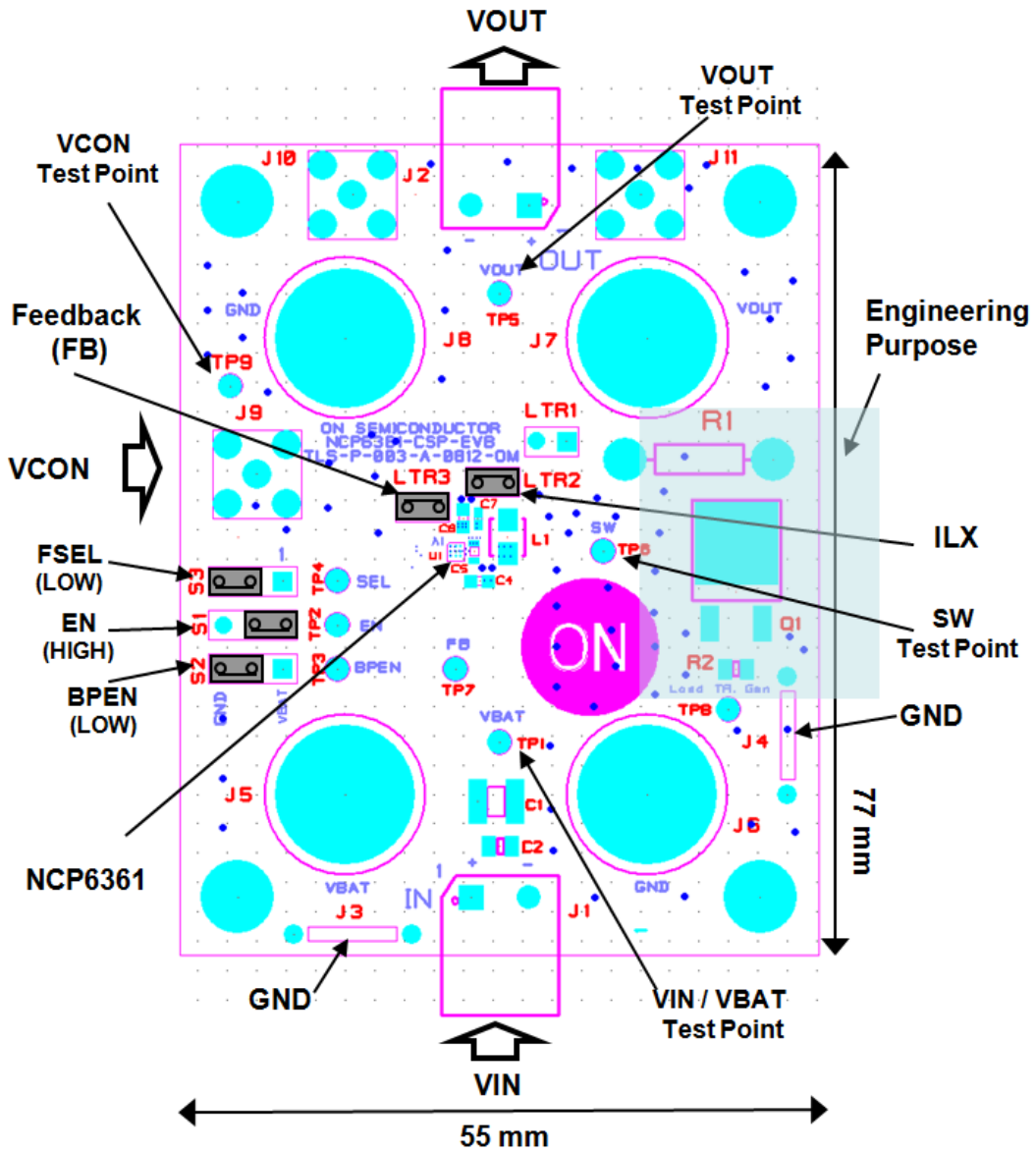

Figure 2. Board Description

NCP6361EVB

BOARD SCHEMATIC

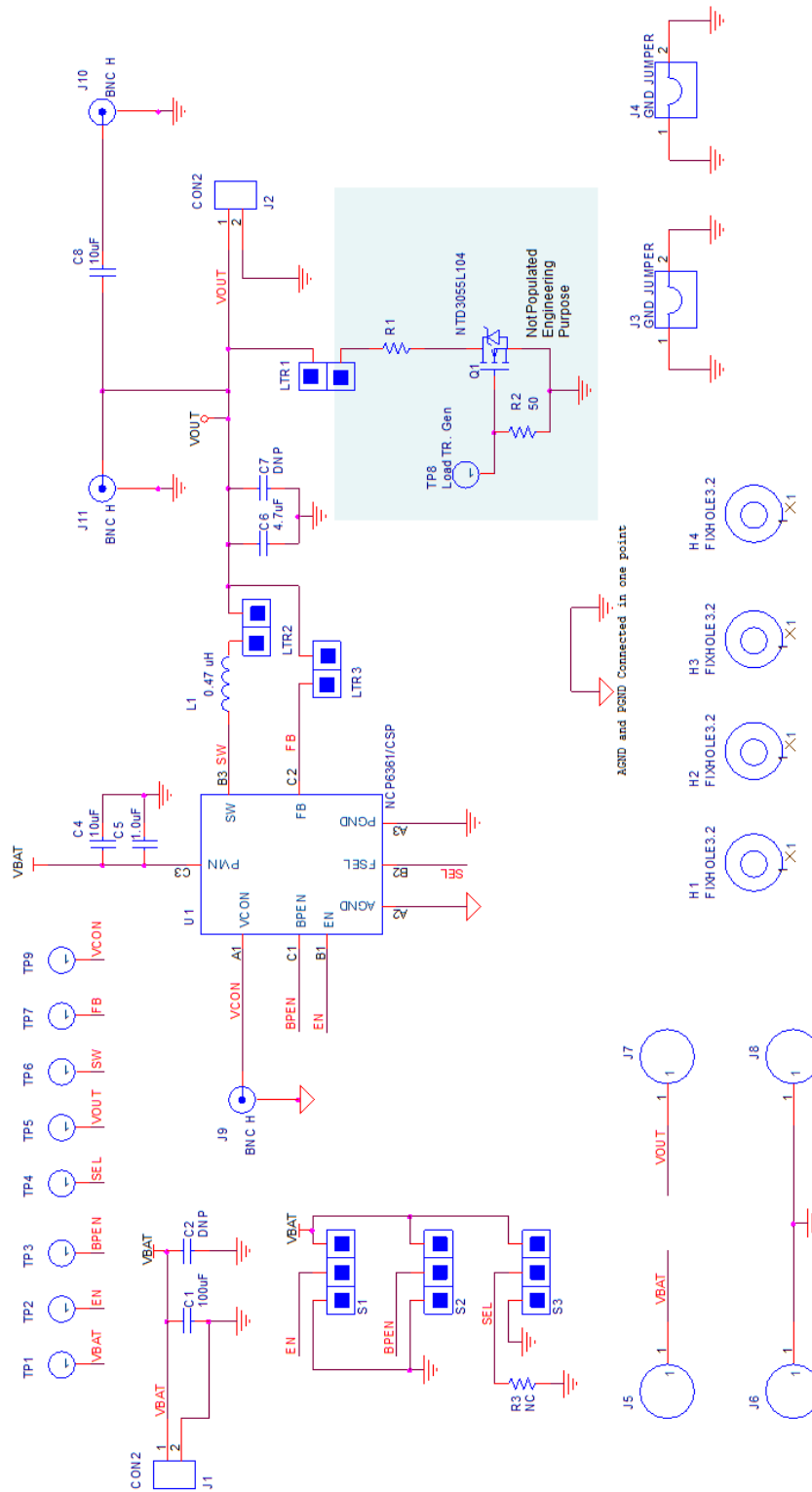



Figure 3. Board Schematic

NCP6361EVb

Table 3. BILL OF MATERIAL – NCP6361 EVALUATION BOARD

Designator	Qty	Description	Value	Tol	Footprint	Manufacturer	Manufacturer Part Number	Lead Free
C1	1	CAP CER 100UF 6.3V 20% X5R 1210	100 μ F	20%	1210			Yes
C2	1	0805	DNP	–	0805		DNP	Yes
C4, C8	2	CAP CER 10UF 16V 10% X5R 0603	10 μ F	10%	0603			Yes
C5	1	CAP CER 1UF 16V X7R 10% 0603	1 μ F	10%	0603			Yes
C6	1	CAP CER 4.7UF 16V X7R 0603	4.7 μ F	5%	0603			Yes
C7	1	0402	DNP		0402		DNP	
R1	1	STRAP	DNP	–			Engineering, DNP	Yes
R2	1	0603 SMD	50, DNP	–	0603			Yes
R3	1	DNP	Open	–	0805		DNP	–
L1	1	2016, inductor 0.47 μ H (1 μ H)	0.47 μ H (1 μ H)		2016	TDK TOKO	TFM201610A–R47M–T00 DFE201612R–H–R47N	Yes
TP1, TP5	2	VBAT, VOUT, Clip Test Point, Hole Diameter 1.6 mm (0.063 mil)	–	–	TP_1.6MMHOLE_KEYSTONE_5010	Keystone	5010	Yes
TP2, TP3, TP4	3	EN, BPEN, FSEL, Clip Test Point, Hole Diameter 1.6 mm (0.063 mil)	–	–	TP_1.6MMHOLE_KEYSTONE_5010	Keystone	5010	Yes
TP6	1	SW, Contact Test Point	–	–	NA	NA	NA	Yes
TP7	1	FB, Clip Test Point, Hole Diameter 1.6 mm (0.063 mil)	–	–	TP_1.6MMHOLE_KEYSTONE_5010	Keystone	5010	Yes
TP8	1	Load Transient Gen, Clip Test Point, Hole Diameter 1.6 mm (0.063 mil)	–	–	TP_1.6MMHOLE_KEYSTONE_5010	Keystone	5010	Yes
TP9	1	VCON, Clip Test Point, Hole Diameter 1.6mm (0.063 mil)	–	–	TP_1.6MMHOLE_KEYSTONE_5010	Keystone	5010	Yes
J1, J2	2	VBAT, VOUT, 2–Pins Male Connector, 5.08 mm Step	–	–	CON2	Phoenix Contact	MSTBA2.52G5.08	Yes
J3, J4	2	Ground Strap, Brass, Diameter 1.0 mm, Pitch 10.16 mm, Height 9.9 mm	–	–	GND_STRP	HARWIN	D3082–46	Yes
J5, J6, J7, J8	4	VBAT, VOUT banana connectors, DC 60 V 16 A. (\varnothing 4 mm nickel–plated brass socket)	–	–	BANANA JACK	Hirschmann	BO 10	Yes
J9, J10, J11	3	SMB connectors	Populate J9 only		SMB/V	IMS	111510001	Yes
LTR1, LTR2, LTR3	3	Breakable Single Row Header (2 Pins)	–	–	CON2–2.54	TYCO Amp	5–826629–0	Yes
S1, S2, S3	3	EN, BPEN, FSEL, Breakable Single Row Header (3 Pins)	–	–	CON3–2.54	TYCO Amp	5–826629–0	Yes
U1	1	NCP6361	–	–	WL CSP9	ON Semiconductor	NCP6361	Yes
Q1	1	NTD3055L104	DNP		DPACK–1234	ON Semiconductor	Engineering, DNP	Yes
H1, H2, H3, H4	4	Standoff nut & Standoff screw	–	–	STANDOFF HOLE	Keystone Electronics	1903C & 4814K–ND	Yes

NOTE DNP = Do Not Populate

ON Semiconductor and  are registered trademarks of Semiconductor Components Industries, LLC (SCILLC). SCILLC owns the rights to a number of patents, trademarks, copyrights, trade secrets, and other intellectual property. A listing of SCILLC's product/patent coverage may be accessed at www.onsemi.com/site/pdf/Patent-Marking.pdf. SCILLC reserves the right to make changes without further notice to any products herein. SCILLC makes no warranty, representation or guarantee regarding the suitability of its products for any particular purpose, nor does SCILLC assume any liability arising out of the application or use of any product or circuit, and specifically disclaims any and all liability, including without limitation special, consequential or incidental damages. "Typical" parameters which may be provided in SCILLC data sheets and/or specifications can and do vary in different applications and actual performance may vary over time. All operating parameters, including "Typicals" must be validated for each customer application by customer's technical experts. SCILLC does not convey any license under its patent rights nor the rights of others. SCILLC products are not designed, intended, or authorized for use as components in systems intended for surgical implant into the body, or other applications intended to support or sustain life, or for any other application in which the failure of the SCILLC product could create a situation where personal injury or death may occur. Should Buyer purchase or use SCILLC products for any such unintended or unauthorized application, Buyer shall indemnify and hold SCILLC and its officers, employees, subsidiaries, affiliates, and distributors harmless against all claims, costs, damages, and expenses, and reasonable attorney fees arising out of, directly or indirectly, any claim of personal injury or death associated with such unintended or unauthorized use, even if such claim alleges that SCILLC was negligent regarding the design or manufacture of the part. SCILLC is an Equal Opportunity/Affirmative Action Employer. This literature is subject to all applicable copyright laws and is not for resale in any manner.

PUBLICATION ORDERING INFORMATION

LITERATURE FULFILLMENT:

Literature Distribution Center for ON Semiconductor
P.O. Box 5163, Denver, Colorado 80217 USA
Phone: 303-675-2175 or 800-344-3860 Toll Free USA/Canada
Fax: 303-675-2176 or 800-344-3867 Toll Free USA/Canada
Email: orderlit@onsemi.com

N. American Technical Support: 800-282-9855 Toll Free
USA/Canada
Europe, Middle East and Africa Technical Support:
Phone: 421 33 790 2910
Japan Customer Focus Center
Phone: 81-3-5817-1050

ON Semiconductor Website: www.onsemi.com
Order Literature: <http://www.onsemi.com/orderlit>
For additional information, please contact your local
Sales Representative

Компания «Океан Электроники» предлагает заключение долгосрочных отношений при поставках импортных электронных компонентов на взаимовыгодных условиях!

Наши преимущества:

- Поставка оригинальных импортных электронных компонентов напрямую с производств Америки, Европы и Азии, а так же с крупнейших складов мира;
- Широкая линейка поставок активных и пассивных импортных электронных компонентов (более 30 млн. наименований);
- Поставка сложных, дефицитных, либо снятых с производства позиций;
- Оперативные сроки поставки под заказ (от 5 рабочих дней);
- Экспресс доставка в любую точку России;
- Помощь Конструкторского Отдела и консультации квалифицированных инженеров;
- Техническая поддержка проекта, помощь в подборе аналогов, поставка прототипов;
- Поставка электронных компонентов под контролем ВП;
- Система менеджмента качества сертифицирована по Международному стандарту ISO 9001;
- При необходимости вся продукция военного и аэрокосмического назначения проходит испытания и сертификацию в лаборатории (по согласованию с заказчиком);
- Поставка специализированных компонентов военного и аэрокосмического уровня качества (Xilinx, Altera, Analog Devices, Intersil, Interpoint, Microsemi, Actel, Aeroflex, Peregrine, VPT, Syfer, Eurofarad, Texas Instruments, MS Kennedy, Miteq, Cobham, E2V, MA-COM, Hittite, Mini-Circuits, General Dynamics и др.);

Компания «Океан Электроники» является официальным дистрибьютором и эксклюзивным представителем в России одного из крупнейших производителей разъемов военного и аэрокосмического назначения «**JONHON**», а так же официальным дистрибьютором и эксклюзивным представителем в России производителя высокотехнологичных и надежных решений для передачи СВЧ сигналов «**FORSTAR**».



JONHON

«**JONHON**» (основан в 1970 г.)

Разъемы специального, военного и аэрокосмического назначения:

(Применяются в военной, авиационной, аэрокосмической, морской, железнодорожной, горно- и нефтедобывающей отраслях промышленности)

«**FORSTAR**» (основан в 1998 г.)

ВЧ соединители, коаксиальные кабели,
кабельные сборки и микроволновые компоненты:

(Применяются в телекоммуникациях гражданского и специального назначения, в средствах связи, РЛС, а так же военной, авиационной и аэрокосмической отраслях промышленности).



Телефон: 8 (812) 309-75-97 (многоканальный)

Факс: 8 (812) 320-03-32

Электронная почта: ocean@oceanchips.ru

Web: <http://oceanchips.ru/>

Адрес: 198099, г. Санкт-Петербург, ул. Калинина, д. 2, корп. 4, лит. А