

## USB MultiSwitch™ Hub

### PRODUCT FEATURES

Data Brief

- USB 2.0 Compatible 4-Port Hub with two upstream host port connections
  - Provides electronic reconfiguration and re-assignment of any of its 4 downstream ports to either of two upstream host ports (“on-the-fly”).
  - Allows multiple USB hosts to share peripherals and enables a user to dynamically assign host ownership.
    - Embedded Mode - 8 (predefined, OEM programmable) configurations for port assignment are selectable via three external control signals.
    - Peripheral Mode - Dedicated select pin for every downstream port (total of 4), selectable edge or level triggered in order to support a wide range of possible switch configurations and styles.
  - Each host has a dedicated Single Transaction Translator (Single-TT) for supporting FS/LS devices, or can also operate in Multi-TT mode where each downstream port has a dedicated Transaction Translator.
- Downstream ports can be disabled or defined as non-removable
- Switching hub can be configured as compound device for support of ‘embedded’ USB peripherals
- Multiple LED modes for maximum implementation flexibility
  - USB Mode - 2 Single-color LEDs for each downstream port (total of 8 LEDs).
  - Host Ownership Mode - 8 Single-Color LEDs indicate which upstream host each of the downstream ports are assigned to.
  - Host Ownership & Port Speed Mode - 8 Dual-Color LEDs are used to indicate which upstream host each of the downstream ports are assigned to, while simultaneously indicating downstream port connection speed.
- Enhanced configuration options available through either a Single Serial I<sup>2</sup>C EEPROM, or SMBus Slave Port
  - VID/PID/DID
  - Port Configuration
  - String Descriptors (each can support a maximum length of 31 characters)
    - Custom Manufacturer String
    - Custom Product String
    - Custom Serial String
  - Assignment of downstream ports to upstream hosts
  - Switching mechanism selection
- Hardware Strapping options allow for configuration without an external EEPROM or SMBus Host
  - Default VID/PID/DID, allows functionality when configuration EEPROM is absent
- Complete USB Specification 2.0 Compatibility
  - Includes USB 2.0 Hi-Speed Transceivers
  - High-Speed (480Mbps/s), Full-Speed (12Mbps/s) and Low-Speed (1.5Mbps/s) compatible
  - Full power management with choice of Individual or Ganged power control
- On-Board 24MHz Crystal Driver Circuit or 24 MHz external clock driver
- Internal PLL for 480MHz USB 2.0 Sampling
- Internal 1.8V Linear Voltage Regulator
- Integrated USB termination and Pull-up/Pull-down resistors
- Internal Short Circuit protection of USB differential signal pins
- 1.8 Volt Low Power Core Operation
- 3.3 Volt I/O with 5V Input Tolerance
- 56-Pin, QFN Lead-free RoHS Compliant Package

**ORDER NUMBER:****USB2524-ABZJ for 56-pin QFN Lead-Free RoHS Compliant Package**

80 ARKAY DRIVE, HAUPPAUGE, NY 11788 (631) 435-6000, FAX (631) 273-3123

Copyright © 2007 SMSC or its subsidiaries. All rights reserved.

Circuit diagrams and other information relating to SMSC products are included as a means of illustrating typical applications. Consequently, complete information sufficient for construction purposes is not necessarily given. Although the information has been checked and is believed to be accurate, no responsibility is assumed for inaccuracies. SMSC reserves the right to make changes to specifications and product descriptions at any time without notice. Contact your local SMSC sales office to obtain the latest specifications before placing your product order. The provision of this information does not convey to the purchaser of the described semiconductor devices any licenses under any patent rights or other intellectual property rights of SMSC or others. All sales are expressly conditional on your agreement to the terms and conditions of the most recently dated version of SMSC's standard Terms of Sale Agreement dated before the date of your order (the "Terms of Sale Agreement"). The product may contain design defects or errors known as anomalies which may cause the product's functions to deviate from published specifications. Anomaly sheets are available upon request. SMSC products are not designed, intended, authorized or warranted for use in any life support or other application where product failure could cause or contribute to personal injury or severe property damage. Any and all such uses without prior written approval of an Officer of SMSC and further testing and/or modification will be fully at the risk of the customer. Copies of this document or other SMSC literature, as well as the Terms of Sale Agreement, may be obtained by visiting SMSC's website at <http://www.smisc.com>. SMSC is a registered trademark of Standard Microsystems Corporation ("SMSC"). Product names and company names are the trademarks of their respective holders.

**SMSC DISCLAIMS AND EXCLUDES ANY AND ALL WARRANTIES, INCLUDING WITHOUT LIMITATION ANY AND ALL IMPLIED WARRANTIES OF MERCHANTABILITY, FITNESS FOR A PARTICULAR PURPOSE, TITLE, AND AGAINST INFRINGEMENT AND THE LIKE, AND ANY AND ALL WARRANTIES ARISING FROM ANY COURSE OF DEALING OR USAGE OF TRADE. IN NO EVENT SHALL SMSC BE LIABLE FOR ANY DIRECT, INCIDENTAL, INDIRECT, SPECIAL, PUNITIVE, OR CONSEQUENTIAL DAMAGES; OR FOR LOST DATA, PROFITS, SAVINGS OR REVENUES OF ANY KIND; REGARDLESS OF THE FORM OF ACTION, WHETHER BASED ON CONTRACT; TORT; NEGLIGENCE OF SMSC OR OTHERS; STRICT LIABILITY; BREACH OF WARRANTY; OR OTHERWISE; WHETHER OR NOT ANY REMEDY OF BUYER IS HELD TO HAVE FAILED OF ITS ESSENTIAL PURPOSE, AND WHETHER OR NOT SMSC HAS BEEN ADVISED OF THE POSSIBILITY OF SUCH DAMAGES.**

## General Description

---

The SMSC 4-Port USB 2.0 Switching Hub Controller acts as two independently controllable USB 2.0 Hubs in a single package with the ability to electronically reassign and reconfigure any of its 4 downstream ports to either of its two upstream USB ports. This allows two USB hosts to share peripherals and to dynamically reconfigure them.

Any configuration of the downstream ports is possible except simultaneous connection to both upstream ports. Up to 8 different configurations can be selected by a dedicated 3-pin interface, or the 4-pin interface can be used to directly assign each port to either of the upstream hosts. An external serial EEPROM (or SMBus Host) is used to store the 8 different configuration parameters. However, 8 predefined configurations, as well as generic VID/PID/DID information, are provided as defaults if no external Serial EEPROM is detected at power up. The SMBus interface can be used to configure the hub as well as dynamically re-assigning downstream ports to upstream hosts. The SMBus interface can be “live” while the hub is operational, and allows an external SMBus host to have full access to re-assign ports on an as-needed basis.

The SMSC 4-Port Switching Hub is fully compliant with the USB 2.0 Specification and will attach to either or both upstream USB hosts as a Full-Speed Hub or as a Full-/High-Speed Hub. The 4 downstream Hub ports support Low-Speed, Full-Speed, and High-Speed (if operating as a High-Speed Hub) downstream devices on all of the enabled downstream ports.

A USB peripheral or USB Hub that is attached to one of the downstream USB2524 ports will be available to one or the other of the upstream USB host controllers, but can never be simultaneously shared with both host controllers. The user can switch a peripheral from one host to the other (on-the-fly), and the peripheral will automatically detach from one host and attach to the other host. Each host will only configure and control the downstream ports that are assigned to it, including full USB power management and suspend/resume operations.

The USB2524 works with an external USB power distribution switch device to control  $V_{BUS}$  switching to downstream ports, and to limit current and sense over-current conditions.

All required resistors on the USB ports are integrated into the Hub. This includes all series termination resistors on D+ and D– pins and all required pull-down and pull-up resistors on D+ and D– pins. The over-current sense inputs for the downstream facing ports have internal pull-up resistors.

Throughout this document the upstream facing port of the hub will be referred to as the upstream port, and the downstream facing ports will be called the downstream ports.

For performance reasons, the Hub provides 1 Transaction Translator (TT) per port (defined as Multi-TT configuration), and each TT has 1512 bytes of periodic buffer space and 272 Bytes of non-periodic buffer space (divided into 4 non-periodic buffers per TT), for a total of 1784 bytes of buffer space for each Transaction Translator.

When configured as a Single-TT Hub (required by USB 2.0 Specification), the Single Transaction Translator will have 1512 bytes of periodic buffer space and 272 bytes of non-periodic buffer space (divided into 4 non-periodic buffers per TT), for a total of 1784 bytes of buffer space for the entire Transaction Translator.

## OEM Selectable Features

A default configuration is available in the USB2524 following a reset. This configuration may be sufficient for some applications. Strapping option pins make it possible to modify a limited sub-set of the configuration options.

The USB2524 may also be configured by an external EEPROM or a microcontroller. When using the microcontroller interface, the Hub appears as an SMBus slave device. If the Hub is pin-strapped for external EEPROM configuration but no external EEPROM is present, then a value of '0' will be written to all configuration data bit fields (the hub will attach to the host with all '0' values).

The USB2524 supports several OEM selectable features:

- Optional OEM configuration via I2C EEPROM or via the industry standard SMBus interface from an external SMBus Host or Microcontroller.
- Compound device support (port is permanently hardwired to a downstream USB peripheral device).
- Hardware strapping options enable configuration of the following features (when not configured via an EEPROM or SMBus host).
  - Non-Removable Ports
  - Port Power Polarity (active high or active low logic)
- Selection of Single (STT) or Multi-Transaction Translator (MTT) capability.
- Selection of Over-Current sensing and Port power control on a individual (port-by-port) or ganged (all ports together) to match the OEM's choice of circuit board component selection.
- Selection of end-user method of switching ports between hosts
  - Embedded Mode: 8 default configurations that are controlled by OEM programmable registers (or Internal default settings).
  - Peripheral Mode: Each wire directly controls one of the 4 downstream ports. The interface is selectable between edge triggered operation or level triggered operation for compatibility with many different mechanical switch configurations or direct control from an external Microcontroller's GPIO pins.
- Enablement of String Descriptor Support, along with the capability to customize each of the 3 different string descriptors (up to a maximum size of 31 characters each)
- Selection of LED Mode: USB Mode, Host Ownership Mode, or Host Ownership Mode with Speed Indication.

# Block Diagram

Revision 1.91 (08-22-07)

5  
PRODUCT PREVIEW

SMSC USB2524

USB MultiSwitch™ Hub

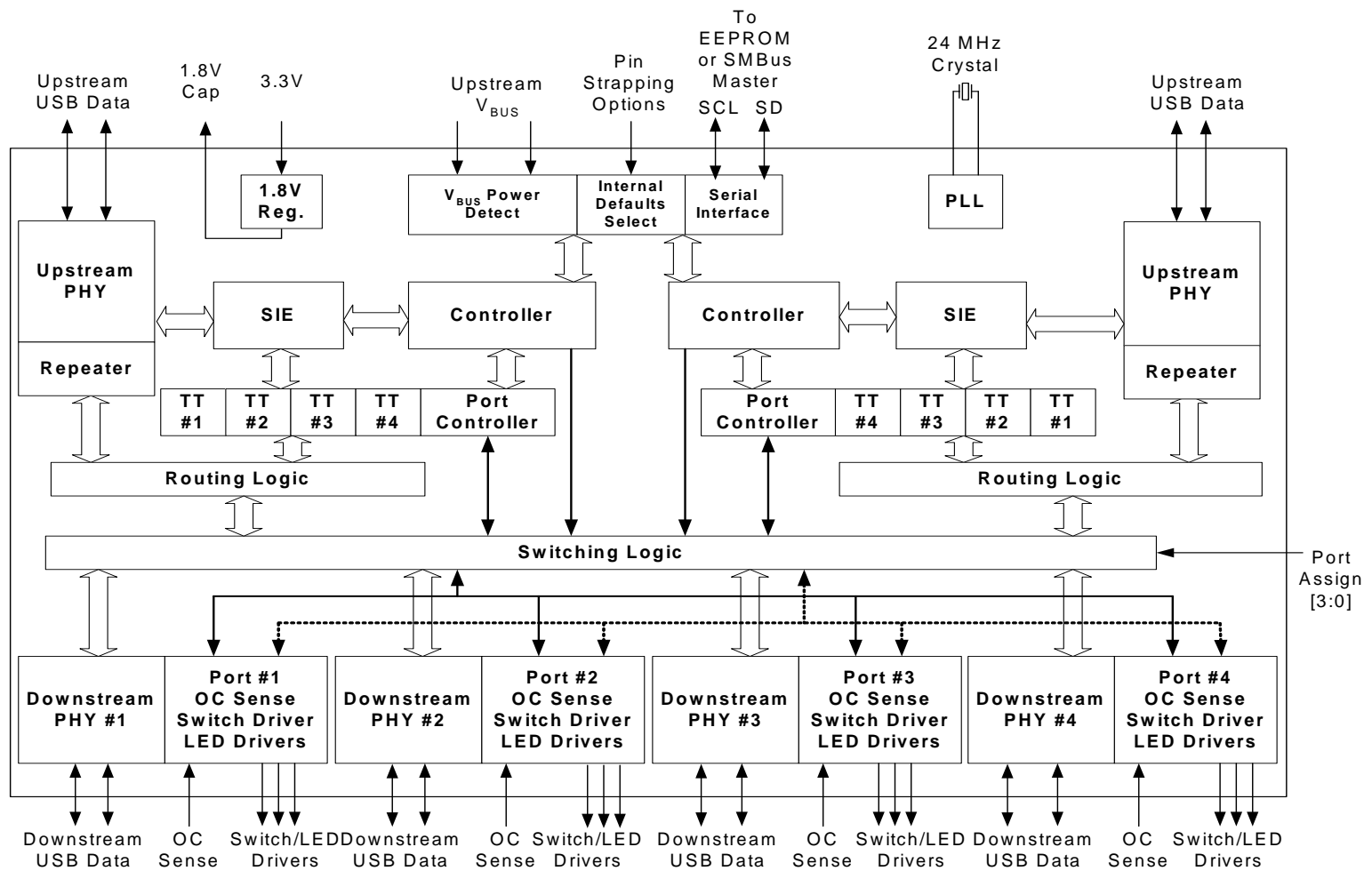
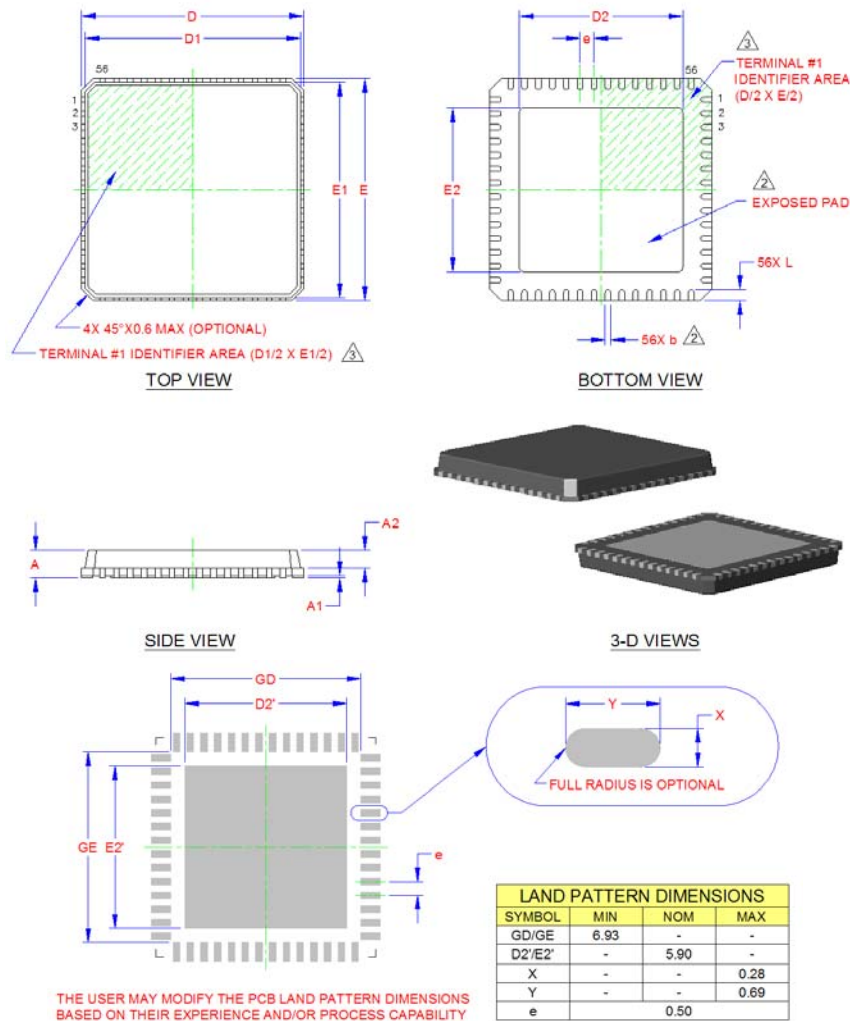

Figure 1 USB2524 Switching Hub Block Diagram

# Package Outline



### RECOMMENDED PCB LAND PATTERN

COMMON DIMENSIONS					
SYMBOL	MIN	NOM	MAX	NOTE	REMARK
A	0.70	-	1.00	-	OVERALL PACKAGE HEIGHT
A1	0	0.02	0.05	-	STANDOFF
A2	-	-	0.90	-	MOLD CAP THICKNESS
D/E	7.85	8.00	8.15	-	X/Y BODY SIZE
D1/E1	7.55	-	7.95	-	X/Y MOLD CAP SIZE
D2/E2	5.75	5.90	6.05	2	X/Y EXPOSED PAD SIZE (USB2524)
L	0.30	-	0.50	-	TERMINAL LENGTH
b	0.18	0.25	0.30	2	TERMINAL WIDTH
e	-	0.50 BSC	-	-	TERMINAL PITCH

#### NOTES:

- ALL DIMENSIONS ARE IN MILLIMETER.
- POSITION TOLERANCE OF EACH TERMINAL AND EXPOSED PAD IS  $\pm 0.05\text{mm}$  AT MAXIMUM MATERIAL CONDITION. DIMENSIONS "b" APPLIES TO PLATED TERMINALS AND IT IS MEASURED BETWEEN 0.15 AND 0.30 mm FROM THE TERMINAL TIP.
- DETAILS OF TERMINAL #1 IDENTIFIER ARE OPTIONAL BUT MUST BE LOCATED WITHIN THE AREA INDICATED.

Figure 2 USB2524 56-Pin QFN Package Outline and Parameters

Компания «Океан Электроники» предлагает заключение долгосрочных отношений при поставках импортных электронных компонентов на взаимовыгодных условиях!

Наши преимущества:

- Поставка оригинальных импортных электронных компонентов напрямую с производств Америки, Европы и Азии, а так же с крупнейших складов мира;
- Широкая линейка поставок активных и пассивных импортных электронных компонентов (более 30 млн. наименований);
- Поставка сложных, дефицитных, либо снятых с производства позиций;
- Оперативные сроки поставки под заказ (от 5 рабочих дней);
- Экспресс доставка в любую точку России;
- Помощь Конструкторского Отдела и консультации квалифицированных инженеров;
- Техническая поддержка проекта, помощь в подборе аналогов, поставка прототипов;
- Поставка электронных компонентов под контролем ВП;
- Система менеджмента качества сертифицирована по Международному стандарту ISO 9001;
- При необходимости вся продукция военного и аэрокосмического назначения проходит испытания и сертификацию в лаборатории (по согласованию с заказчиком);
- Поставка специализированных компонентов военного и аэрокосмического уровня качества (Xilinx, Altera, Analog Devices, Intersil, Interpoint, Microsemi, Actel, Aeroflex, Peregrine, VPT, Syfer, Eurofarad, Texas Instruments, MS Kennedy, Miteq, Cobham, E2V, MA-COM, Hittite, Mini-Circuits, General Dynamics и др.);

Компания «Океан Электроники» является официальным дистрибьютором и эксклюзивным представителем в России одного из крупнейших производителей разъемов военного и аэрокосмического назначения «JONHON», а так же официальным дистрибьютором и эксклюзивным представителем в России производителя высокотехнологичных и надежных решений для передачи СВЧ сигналов «FORSTAR».



## JONHON

«JONHON» (основан в 1970 г.)

Разъемы специального, военного и аэрокосмического назначения:

(Применяются в военной, авиационной, аэрокосмической, морской, железнодорожной, горно- и нефтедобывающей отраслях промышленности)

«FORSTAR» (основан в 1998 г.)

ВЧ соединители, коаксиальные кабели, кабельные сборки и микроволновые компоненты:

(Применяются в телекоммуникациях гражданского и специального назначения, в средствах связи, РЛС, а так же военной, авиационной и аэрокосмической отраслях промышленности).



Телефон: 8 (812) 309-75-97 (многоканальный)

Факс: 8 (812) 320-03-32

Электронная почта: [ocean@oceanchips.ru](mailto:ocean@oceanchips.ru)

Web: <http://oceanchips.ru/>

Адрес: 198099, г. Санкт-Петербург, ул. Калинина, д. 2, корп. 4, лит. А