



Is Now Part of



ON Semiconductor®

To learn more about ON Semiconductor, please visit our website at
www.onsemi.com

Please note: As part of the Fairchild Semiconductor integration, some of the Fairchild orderable part numbers will need to change in order to meet ON Semiconductor's system requirements. Since the ON Semiconductor product management systems do not have the ability to manage part nomenclature that utilizes an underscore (_), the underscore (_) in the Fairchild part numbers will be changed to a dash (-). This document may contain device numbers with an underscore (_). Please check the ON Semiconductor website to verify the updated device numbers. The most current and up-to-date ordering information can be found at www.onsemi.com. Please email any questions regarding the system integration to Fairchild_questions@onsemi.com.

ON Semiconductor and the ON Semiconductor logo are trademarks of Semiconductor Components Industries, LLC dba ON Semiconductor or its subsidiaries in the United States and/or other countries. ON Semiconductor owns the rights to a number of patents, trademarks, copyrights, trade secrets, and other intellectual property. A listing of ON Semiconductor's product/patent coverage may be accessed at www.onsemi.com/site/pdf/Patent-Marking.pdf. ON Semiconductor reserves the right to make changes without further notice to any products herein. ON Semiconductor makes no warranty, representation or guarantee regarding the suitability of its products for any particular purpose, nor does ON Semiconductor assume any liability arising out of the application or use of any product or circuit, and specifically disclaims any and all liability, including without limitation special, consequential or incidental damages. Buyer is responsible for its products and applications using ON Semiconductor products, including compliance with all laws, regulations and safety requirements or standards, regardless of any support or applications information provided by ON Semiconductor. "Typical" parameters which may be provided in ON Semiconductor data sheets and/or specifications can and do vary in different applications and actual performance may vary over time. All operating parameters, including "Typicals" must be validated for each customer application by customer's technical experts. ON Semiconductor does not convey any license under its patent rights nor the rights of others. ON Semiconductor products are not designed, intended, or authorized for use as a critical component in life support systems or any FDA Class 3 medical devices or medical devices with a same or similar classification in a foreign jurisdiction or any devices intended for implantation in the human body. Should Buyer purchase or use ON Semiconductor products for any such unintended or unauthorized application, Buyer shall indemnify and hold ON Semiconductor and its officers, employees, subsidiaries, affiliates, and distributors harmless against all claims, costs, damages, and expenses, and reasonable attorney fees arising out of, directly or indirectly, any claim of personal injury or death associated with such unintended or unauthorized use, even if such claim alleges that ON Semiconductor was negligent regarding the design or manufacture of the part. ON Semiconductor is an Equal Opportunity/Affirmative Action Employer. This literature is subject to all applicable copyright laws and is not for resale in any manner.



FSA3051 — High Performance SPDT Analog Switch with Over-Voltage Tolerance

Features

- Low On Capacitance: 7.7 pF Typical
- Low On Resistance: 6 Ω Typical
- Low Power Consumption: 1 μA Maximum
 - 15 μA Maximum I_{CC}T over an Expanded Voltage Range (V_{IN}=1.8 V, V_{CC}=5.5 V)
- Wide -3 db Bandwidth: 1.0 GHz
- Packaged in Ultra Small 6-Lead TMLP
- Broad V_{CC} Operating Range: 1.6 V to 5.5 V
- Over-Voltage Tolerance (OVT) on all Data Ports up to 6 V without External Components

Applications

- Cell Phone, PDA, Digital Camera, and Notebook
- LCD Monitor, TV, and Set-Top Box

Description

The FSA3051 is a 6 Ω, bi-directional, low-power, two-port, high-speed, Single Pole / Double Throw (SPDT) analog switch. It features an extremely low on capacitance (C_{ON}) of 7.7 pF and wide bandwidth of 1.0 GHz.

The FSA3051 contains special circuitry on the switch I/O pins for applications where the V_{CC} supply is powered-off (V_{CC}=0 V), which allows the device to withstand an over-voltage condition. This device is designed to minimize current consumption even when the control voltage applied to the select (S) pin is lower than the supply voltage (V_{CC}). This feature is especially valuable to ultra-portable applications, such as cell phones, allowing for direct interface with the general-purpose I/Os of the baseband processor. Other applications include switching in portable cell phones, PDAs, digital cameras, printers, and notebook computers.

Ordering Information

Part Number	Top Mark	Operating Temperature Range	Package
FSA3051TMX	NT	-40 to +85°C	6-Lead, Dual, Ultra-ultrathin Molded Leadless Package (TMLP), 1.0 x 1.0 mm. Top left unit orientation in carrier tape.
FSA3051TMX_F147	NT	-40 to +85°C	6-Lead, Dual, Ultra-ultrathin Molded Leadless Package (TMLP), 1.0 x 1.0 mm. Bottom left unit orientation in carrier tape.

MicroPak™ is a trademark of Fairchild Semiconductor Corporation.

Analog Symbols

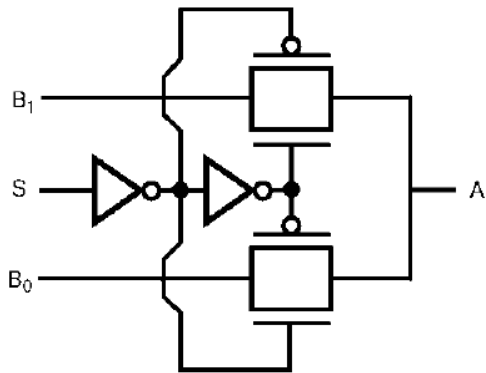

Figure 1. Logic Symbol

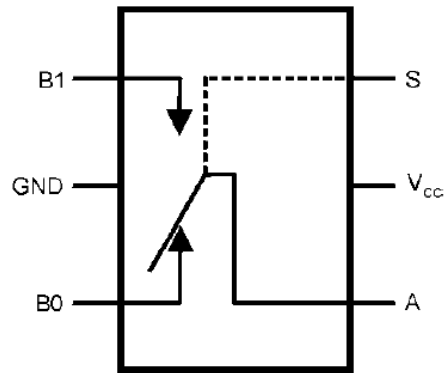

Figure 2. Analog Symbol

Pin Assignments

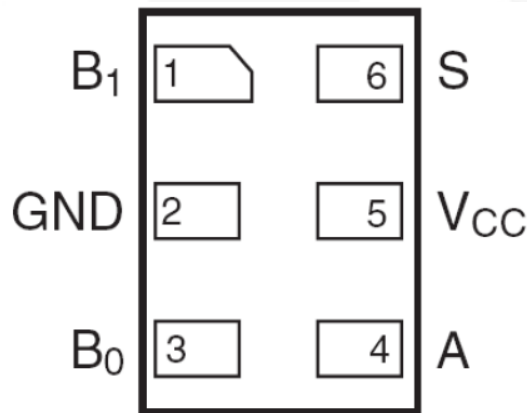

Figure 3. 6-Lead TMLP (Top-Through View)

Pin Definitions

UMLP Pin#	Name	Description
1	B ₁	Data Port
2	GND	Ground
3	B ₀	Data Port
4	A	Data Port
5	V _{CC}	Supply Voltage
6	S	Switch Select

Truth Table

S	Function
LOW	B ₀ connected to A
HIGH	B ₁ connected to A

Notes:

1. LOW $\leq V_{IL}$.
2. HIGH $\geq V_{IH}$.

Absolute Maximum Ratings

Stresses exceeding the absolute maximum ratings may damage the device. The device may not function or be operable above the recommended operating conditions and stressing the parts to these levels is not recommended. In addition, extended exposure to stresses above the recommended operating conditions may affect device reliability. The absolute maximum ratings are stress ratings only.

Symbol	Parameter	Min.	Max.	Unit
V _{CC}	Supply Voltage	-0.5	6.0	V
V _{CNTRL}	DC Input Voltage ⁽³⁾	-0.5	V _{CC}	V
V _{SW}	DC Switch I/O Voltage ⁽³⁾	-0.50	6.00	V
I _{IK}	DC Input Diode Current	-50		mA
I _{OUT}	DC Output Current		50	mA
T _{STG}	Storage Temperature	-65	+150	°C
MSL	Moisture Sensitivity Level (JEDEC J-STD-020A)		1	Level
ESD	Human Body Model, ANSI/ESDA/JEDEC JS-001-2012	All Pins	2	kV
		I/O to GND	2	
		Power to GND	2	
	Charged Device Model, JEDEC: JESD22-C101	1		

Note:

3. The input and output negative ratings may be exceeded if the input and output diode current ratings are observed.

Recommended Operating Conditions

The Recommended Operating Conditions table defines the conditions for actual device operation. Recommended operating conditions are specified to ensure optimal performance to the datasheet specifications. Fairchild does not recommend exceeding them or designing to Absolute Maximum Ratings.

Symbol	Parameter	Min.	Max.	Unit
V _{CC}	Supply Voltage	1.6	5.5	V
V _{CNTRL}	Control Input Voltage (S) ⁽⁴⁾	0	V _{CC}	V
V _{SW}	Switch I/O Voltage	-0.5	5.5	V
T _A	Operating Temperature	-40	+85	°C

Note:

4. The control input must be held HIGH or LOW and it must not float.

DC Electrical Characteristics

All typical value are at $T_A=25^\circ\text{C}$ unless otherwise specified.

Symbol	Parameter	Condition	V_{CC} (V)	$T_A=-40^\circ\text{C}$ to $+85^\circ\text{C}$			Unit
				Min.	Typ.	Max.	
V_{IK}	Clamp Diode Voltage	$I_{IN}=-18\text{ mA}$	3.0			-1.2	V
V_{IH}	Input Voltage High		1.8 to 4.3	1.3			V
			4.3 to 5.5	1.7			
V_{IL}	Input Voltage Low		1.8 to 4.3			0.5	V
			4.3 to 5.5			0.7	
I_{IN}	Control Input Leakage	$V_{CNTRL}=0$ to V_{CC}	1.8	-1		1	μA
			5.5	-1		1	
I_{OZ}	Off State Leakage	$V_{SW}=0\text{ V}$ to V_{CC}	1.8	-2		2	μA
		$V_{SW}=0\text{ V}$ to 3.6 V	5.5	-2		2	
I_{OFF}	Power-Off Leakage Current (All I/O Ports)	$V_{SW}=0\text{ V}$ to 4.3 V , $V_{CC}=0\text{ V}$ Figure 5	0	-2		2	μA
R_{ON}	Switch On Resistance ⁽⁵⁾	$V_{SW}=0.4\text{ V}$, $I_{ON}=-8\text{ mA}$ Figure 4	3.0		4	10	Ω
		$V_{SW}=1.8\text{ V}$, $I_{ON}=-8\text{ mA}$ Figure 4	3.0		6	10	
R_{ON}	Switch On Resistance ⁽⁵⁾	$V_{SW}=0.4\text{ V}$, $I_{ON}=-8\text{ mA}$ Figure 4	1.8		6	10	Ω
		$V_{SW}=1.8\text{ V}$, $I_{ON}=-8\text{ mA}$ Figure 4	1.8		14	25	
ΔR_{ON}	On Resistance Match Between Channels ^(5,6)	$V_{SW}=0.4\text{ V}$, $I_{ON}=-8\text{ mA}$	3.0		35		$\text{m}\Omega$
			1.8		40		
I_{CC}	Quiescent Supply Current	$V_{CNTRL}=0$ or V_{CC} , $I_{OUT}=0$	5.5			1	μA
I_{CCT}	Increase in I_{CC} Current per Control Voltage and V_{CC}	$V_{CNTRL}=1.8\text{ V}$	3.0			10	μA
		$V_{CNTRL}=2.6\text{ V}$	5.5			10	
		$V_{CNTRL}=1.8\text{ V}$	5.5			15	

Notes:

5. Measured by the voltage drop between A and Bn pins at the indicated current through the switch. On resistance is determined by the lower of the voltage on the two (A or Bn ports).
6. $\Delta R_{ON} = R_{ON}$ maximum - R_{ON} minimum measured at identical V_{CC} , temperature, and voltage levels.
7. Guaranteed by characterization.

AC Electrical Characteristics⁽⁸⁾

All typical value are for $V_{CC}=3.3$ V at $T_A=25^\circ\text{C}$ unless otherwise specified.

Symbol	Parameter	Condition	V_{CC} (V)	$T_A=-40^\circ\text{C}$ to $+85^\circ\text{C}$			Unit
				Min.	Typ.	Max.	
t_{ON}	Turn-On Time S to Output	$R_L=50\ \Omega$, $C_L=5\ \text{pF}$, $V_{SW}=0.8\ \text{V}$, Figure 6, Figure 7	3.0 to 3.6		34		ns
			1.8		110		
t_{OFF}	Turn-Off Time S to Output	$R_L=50\ \Omega$, $C_L=5\ \text{pF}$, $V_{SW}=0.8\ \text{V}$, Figure 6, Figure 7	3.0 to 3.6		23		ns
			1.8		50		
t_{PD}	Propagation Delay	$C_L=5\ \text{pF}$, $R_L=50\ \Omega$, Figure 6, Figure 8	3.3		0.2		ns
			1.8		0.3		
t_{BBM}	Break-Before-Make	$R_L=50\ \Omega$, $C_L=5\ \text{pF}$, $V_{SW1}=V_{SW2}=0.8\ \text{V}$, Figure 9	3.0 to 3.6	15		50	ns
			1.8			100	
O_{IRR}	Off Isolation	$R_L=50\ \Omega$, $f=240\ \text{MHz}$, Figure 11	1.8		-20		dB
			3.0 to 3.6		-23		
Xtalk	Crosstalk	$R_L=50\ \Omega$, $f=240\ \text{MHz}$, Figure 12	1.8		-18		dB
			3.0 to 3.6		-23		
BW	-3 db Bandwidth	$R_L=50\ \Omega$, $C_L=0\ \text{pF}$, $V_{SW}=0.4\ \text{V}$	1.8		810		MHz
		$R_L=50\ \Omega$, $C_L=0\ \text{pF}$, Figure 10	3.0 to 3.6		1		GHz
		$R_L=50\ \Omega$, $C_L=5\ \text{pF}$, Figure 10			750		MHz

Note:

8. Guaranteed by characterization. Not production tested.

Capacitance⁽⁹⁾

Symbol	Parameter	Condition	V_{CC} (V)	$T_A=-40^\circ\text{C}$ to $+85^\circ\text{C}$			Unit
				Min.	Typ.	Max.	
C_{IN}	Control Pin Input Capacitance		0		1.5		pF
C_{ON}	A Port On Capacitance	$f=1\ \text{MHz}$,	3.0		7.7		
		$f=240\ \text{MHz}$, Figure 14	3.3		7.7		
		$f=1\ \text{MHz}$,	1.8		10.0		
		$f=240\ \text{MHz}$, Figure 14	1.8		5.0		
C_{OFF}	Bn Port Off Capacitance	$f=1\ \text{MHz}$	3.0		3.3		
		$f=240\ \text{MHz}$, Figure 13	3.3		3.3		
		$f=1\ \text{MHz}$	1.8		5.0		
		$f=240\ \text{MHz}$, Figure 13	1.8		4.0		

Note:

9. Not production tested.

Test Diagrams

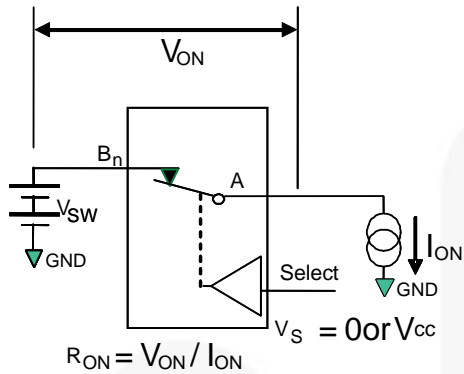
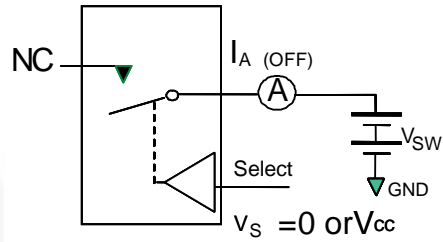
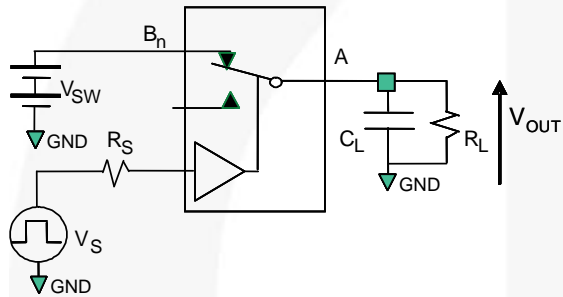

Figure 4. On Resistance



**Each switch port is tested separately

Figure 5. Off Leakage



R_L , R_S , and C_L are functions of the application environment (see AC Tables for specific values)
 C_L includes test fixture and stray capacitance.

Figure 6. AC Test Circuit Load

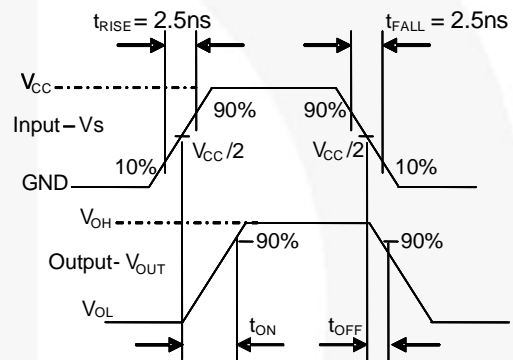

Figure 7. Turn-On / Turn-Off Waveforms

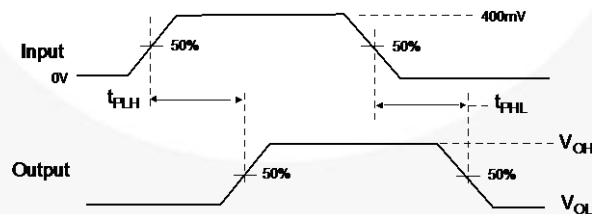

Figure 8. Propagation Delay ($t_{rTF} = 500$ ps)

Test Diagrams (Continued)

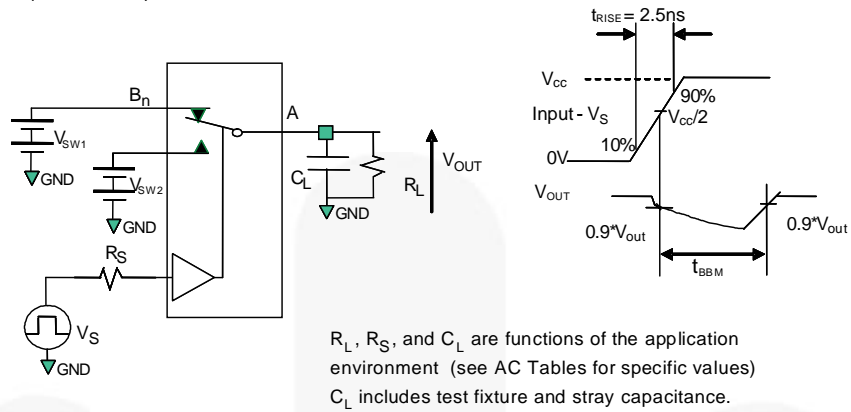

Figure 9. Break-Before-Make Interval Timing

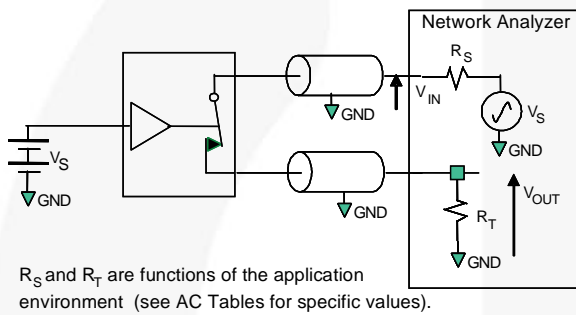

Figure 10. Bandwidth

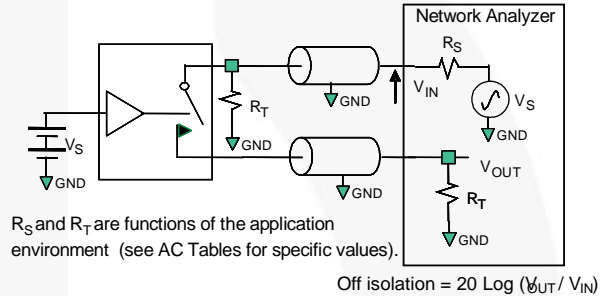

Figure 11. Channel Off Isolation

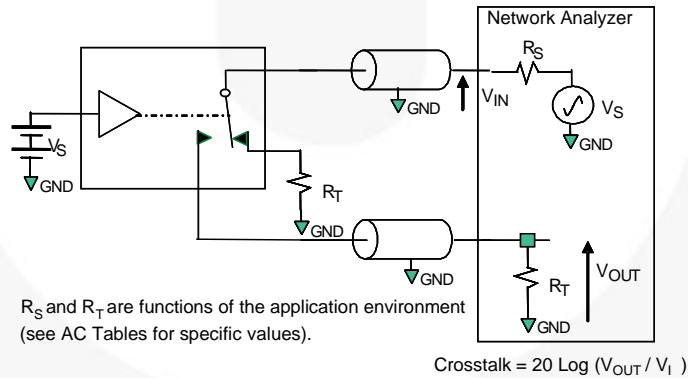

Figure 12. Channel-to-Channel Crosstalk

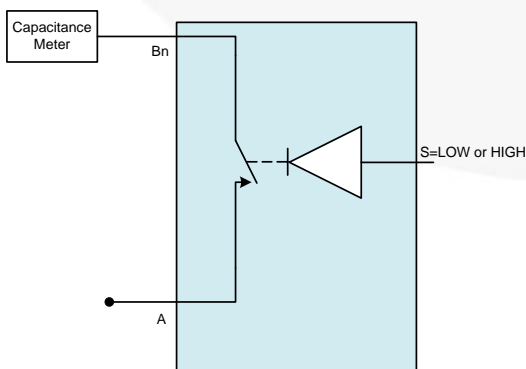

Figure 13. Channel Off Capacitance

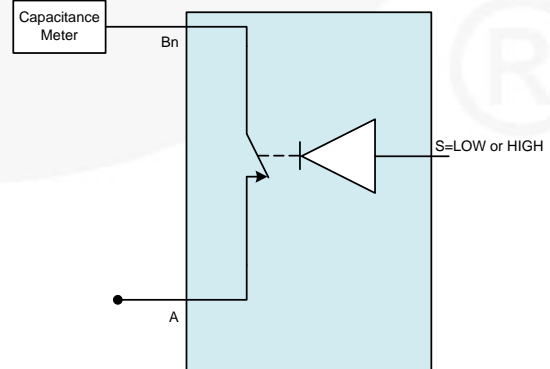
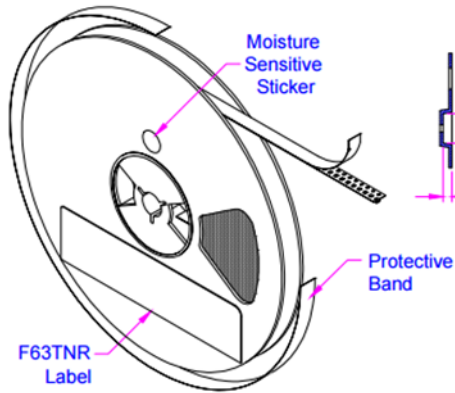

Figure 14. Channel On Capacitance

Carrier Tape Orientation

TMLP TNR CONFIGURATION



Plastic Reel

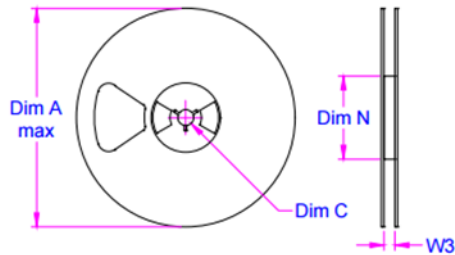

Embossed Carrier Tape

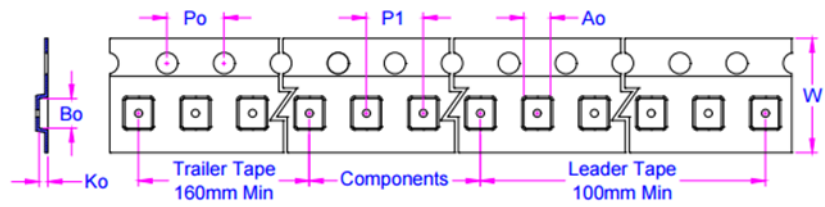

Unit Orientation - refer to below table per MOD orientation

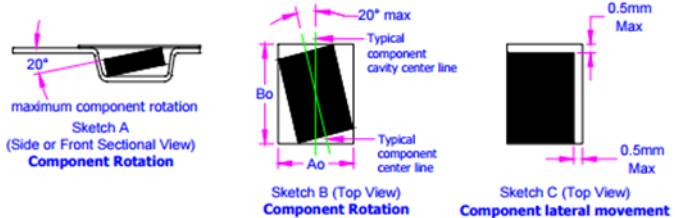
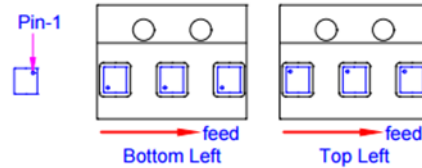

Notes:

Ao, Bo, and Ko dimensions are determined with respect to the EIA-481 rotational and lateral movement requirements (see sketches A, B, & C). Camber requirement also compliant to above mentioned standards.

Figure 15. TMLP Carrier Tape Packing

Part Number	Unit Orientation
FSA3051TMX	Top Left
FSA3051TMX_F147	Bottom Left

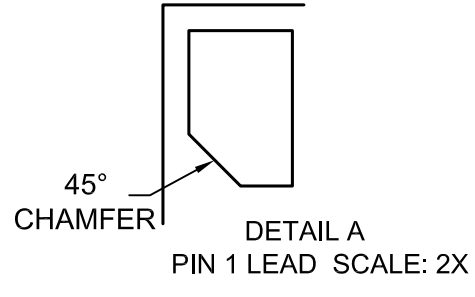
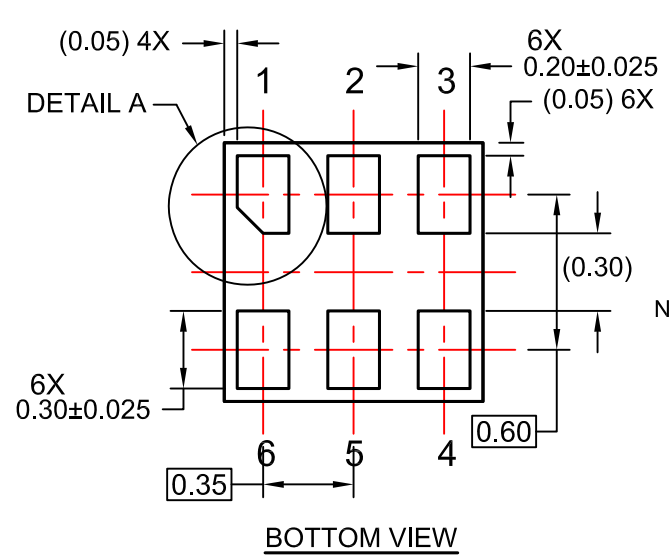
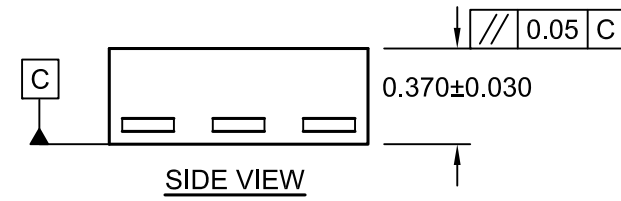
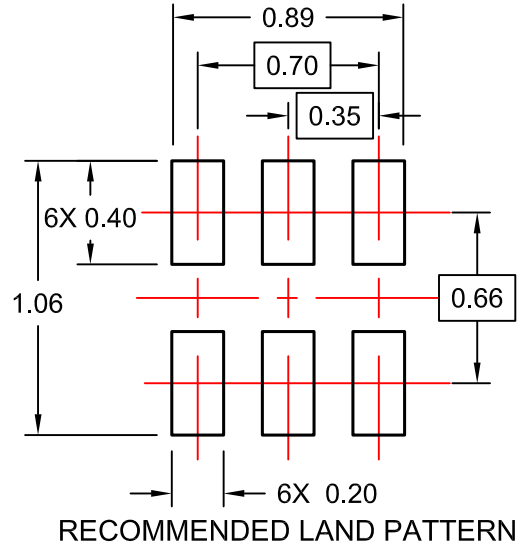
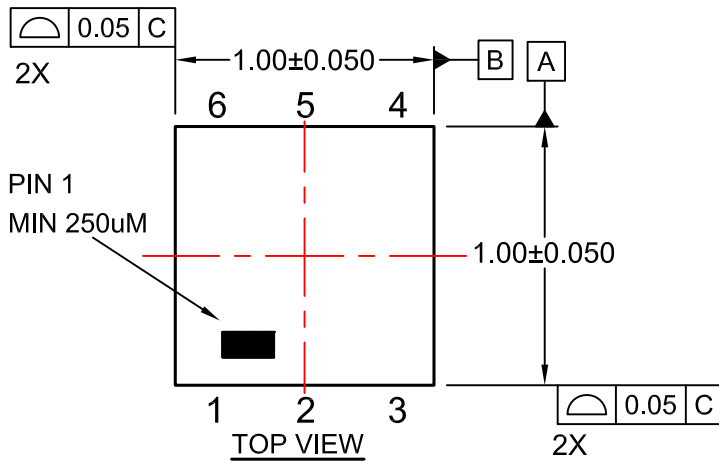

- NOTES:
- A. NO JEDEC STANDARD APPLIES
 - B. DIMENSIONS ARE IN MILLIMETERS.
 - C. DIMENSIONS AND TOLERANCES PER ASME Y14.5M, 2009
 - D. LANDPATTERN RECOMMENDATION IS BASED ON FSC DESIGN.
 - E. DRAWING FILENAME AND REVISION: MKT-TMLP06AREV2

⊕	0.05(M)	C	B	A
	0.05	C		



ON Semiconductor and  are trademarks of Semiconductor Components Industries, LLC dba ON Semiconductor or its subsidiaries in the United States and/or other countries. ON Semiconductor owns the rights to a number of patents, trademarks, copyrights, trade secrets, and other intellectual property. A listing of ON Semiconductor's product/patent coverage may be accessed at www.onsemi.com/site/pdf/Patent-Marking.pdf. ON Semiconductor reserves the right to make changes without further notice to any products herein. ON Semiconductor makes no warranty, representation or guarantee regarding the suitability of its products for any particular purpose, nor does ON Semiconductor assume any liability arising out of the application or use of any product or circuit, and specifically disclaims any and all liability, including without limitation special, consequential or incidental damages. Buyer is responsible for its products and applications using ON Semiconductor products, including compliance with all laws, regulations and safety requirements or standards, regardless of any support or applications information provided by ON Semiconductor. "Typical" parameters which may be provided in ON Semiconductor data sheets and/or specifications can and do vary in different applications and actual performance may vary over time. All operating parameters, including "Typicals" must be validated for each customer application by customer's technical experts. ON Semiconductor does not convey any license under its patent rights nor the rights of others. ON Semiconductor products are not designed, intended, or authorized for use as a critical component in life support systems or any FDA Class 3 medical devices or medical devices with a same or similar classification in a foreign jurisdiction or any devices intended for implantation in the human body. Should Buyer purchase or use ON Semiconductor products for any such unintended or unauthorized application, Buyer shall indemnify and hold ON Semiconductor and its officers, employees, subsidiaries, affiliates, and distributors harmless against all claims, costs, damages, and expenses, and reasonable attorney fees arising out of, directly or indirectly, any claim of personal injury or death associated with such unintended or unauthorized use, even if such claim alleges that ON Semiconductor was negligent regarding the design or manufacture of the part. ON Semiconductor is an Equal Opportunity/Affirmative Action Employer. This literature is subject to all applicable copyright laws and is not for resale in any manner.

PUBLICATION ORDERING INFORMATION

LITERATURE FULFILLMENT:

Literature Distribution Center for ON Semiconductor
19521 E. 32nd Pkwy, Aurora, Colorado 80011 USA
Phone: 303-675-2175 or 800-344-3860 Toll Free USA/Canada
Fax: 303-675-2176 or 800-344-3867 Toll Free USA/Canada
Email: orderlit@onsemi.com

N. American Technical Support: 800-282-9855 Toll Free
USA/Canada
Europe, Middle East and Africa Technical Support:
Phone: 421 33 790 2910
Japan Customer Focus Center
Phone: 81-3-5817-1050

ON Semiconductor Website: www.onsemi.com
Order Literature: <http://www.onsemi.com/orderlit>
For additional information, please contact your local
Sales Representative

Mouser Electronics

Authorized Distributor

Click to View Pricing, Inventory, Delivery & Lifecycle Information:

[ON Semiconductor:](#)

[FSA3051TMX](#)

Компания «Океан Электроники» предлагает заключение долгосрочных отношений при поставках импортных электронных компонентов на взаимовыгодных условиях!

Наши преимущества:

- Поставка оригинальных импортных электронных компонентов напрямую с производств Америки, Европы и Азии, а так же с крупнейших складов мира;
- Широкая линейка поставок активных и пассивных импортных электронных компонентов (более 30 млн. наименований);
- Поставка сложных, дефицитных, либо снятых с производства позиций;
- Оперативные сроки поставки под заказ (от 5 рабочих дней);
- Экспресс доставка в любую точку России;
- Помощь Конструкторского Отдела и консультации квалифицированных инженеров;
- Техническая поддержка проекта, помощь в подборе аналогов, поставка прототипов;
- Поставка электронных компонентов под контролем ВП;
- Система менеджмента качества сертифицирована по Международному стандарту ISO 9001;
- При необходимости вся продукция военного и аэрокосмического назначения проходит испытания и сертификацию в лаборатории (по согласованию с заказчиком);
- Поставка специализированных компонентов военного и аэрокосмического уровня качества (Xilinx, Altera, Analog Devices, Intersil, Interpoint, Microsemi, Actel, Aeroflex, Peregrine, VPT, Syfer, Eurofarad, Texas Instruments, MS Kennedy, Miteq, Cobham, E2V, MA-COM, Hittite, Mini-Circuits, General Dynamics и др.);

Компания «Океан Электроники» является официальным дистрибьютором и эксклюзивным представителем в России одного из крупнейших производителей разъемов военного и аэрокосмического назначения «JONHON», а так же официальным дистрибьютором и эксклюзивным представителем в России производителя высокотехнологичных и надежных решений для передачи СВЧ сигналов «FORSTAR».



JONHON

«JONHON» (основан в 1970 г.)

Разъемы специального, военного и аэрокосмического назначения:

(Применяются в военной, авиационной, аэрокосмической, морской, железнодорожной, горно- и нефтедобывающей отраслях промышленности)

«FORSTAR» (основан в 1998 г.)

ВЧ соединители, коаксиальные кабели, кабельные сборки и микроволновые компоненты:

(Применяются в телекоммуникациях гражданского и специального назначения, в средствах связи, РЛС, а так же военной, авиационной и аэрокосмической отраслях промышленности).



Телефон: 8 (812) 309-75-97 (многоканальный)

Факс: 8 (812) 320-03-32

Электронная почта: ocean@oceanchips.ru

Web: <http://oceanchips.ru/>

Адрес: 198099, г. Санкт-Петербург, ул. Калинина, д. 2, корп. 4, лит. А