

40 W bridge car radio amplifier with low voltage operation

Datasheet - production data

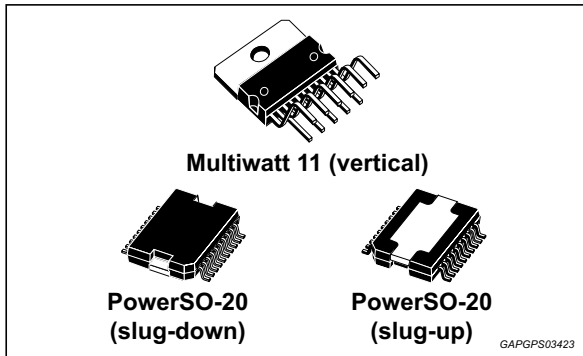

- Protections:
 - Short circuit (to GND, to V_S , across the load)
 - Very inductive loads
 - Chip over temperature
 - Load dump
 - Open GND
 - ESD

Description

The TDA7391LV is a bridge class AB audio power amplifier for car radio applications.

The high power capability together with the possibility to operate either in differential input mode or single ended input mode makes it suitable for high end car radio equipment. The exclusive fully complementary output stage and the internal fixed gain configuration drop the external component count.

The on board clipping detector allows easy implementation of gain compression systems.

It is moreover compliant to the most recent OEM specifications for low voltage operation ('start-stop' battery profile during engine stop), and e-call functions.

Features

- High power capability:
 - 40 W/ 4 Ω max
 - 45 W/ 3.2 Ω max
 - 32 W/ 3.2 Ω @ $V_S = 14.4$ V, $f = 1$ kHz, THD = 10 %
 - 26 W/ 4 Ω @ $V_S = 14.4$ V, $f = 1$ kHz, THD = 10%
- Differential inputs (either single ended or differential input signal is accepted)
- Minimum external component count
- Standby function (CMOS compatible)
- Capable to operate to 6 V - 'start-stop' and 'e-call' compatibility

Table 1. Device summary

Order code	Package	Packing
TDA7391LV	Multiwatt 11	Tube
TDA7391LVDP	PowerSO-20 (slug-down)	Tube
TDA7391LVDPTR		Tape and reel
TDA7391LVDPDU	PowerSO-20 (slug-up)	Tube
TDA7391LVDPDTR		Tape and reel

Contents

- 1 Block diagram, test and application circuit 5**
 - 1.1 Block diagram 5
 - 1.2 Test and application circuit 6

- 2 Pins description 7**

- 3 Electrical specifications 9**
 - 3.1 Absolute maximum ratings 9
 - 3.2 Thermal data 9
 - 3.3 Electrical characteristics 9
 - 3.4 Low voltage operation ('start stop') 11
 - 3.5 Electrical characteristics curves 12

- 4 Package information 16**
 - 4.1 Multiwatt 11 (vertical) package mechanical data 16
 - 4.2 PowerSO-20 (slug-down) package mechanical data 18
 - 4.3 PowerSO-20 (slug-up) package mechanical data 20

- 5 Revision history 22**

List of tables

Table 1.	Device summary	1
Table 2.	Pins function	7
Table 3.	Absolute maximum ratings	9
Table 4.	Thermal data	9
Table 5.	Electrical characteristics	9
Table 6.	Multiwatt 11 (vertical) package mechanical data	16
Table 7.	PowerSO-20 (slug-down) package mechanical data	18
Table 8.	PowerSO-20 (slug-up) package mechanical data	20
Table 9.	Document revision history	22

List of figures

Figure 1.	Block diagram	5
Figure 2.	Test and application circuit	6
Figure 3.	Multiwatt 11 pins connection (top view)	7
Figure 4.	PowerSO-20 pins connection	7
Figure 5.	Worst case battery cranking curve sample 1	11
Figure 6.	Worst case battery cranking curve sample 2	11
Figure 7.	Quiescent current vs. supply voltage	12
Figure 8.	Output power vs. supply voltage ($R_L = 3.2 \Omega$)	12
Figure 9.	Output power vs. supply voltage ($R_L = 4 \Omega$)	12
Figure 10.	Output power vs. supply voltage ($R_L = 8 \Omega$)	12
Figure 11.	Distortion vs. output power ($R_L = 3.2 \Omega$)	12
Figure 12.	Distortion vs. frequency ($R_L = 3.2 \Omega$)	12
Figure 13.	Distortion vs. output power ($R_L = 4 \Omega$)	13
Figure 14.	Distortion vs. frequency ($R_L = 4 \Omega$)	13
Figure 15.	Distortion vs. output power ($R_L = 8 \Omega$)	13
Figure 16.	Distortion vs. frequency ($R_L = 8 \Omega$)	13
Figure 17.	Distortion vs. output power ($R_L = 4 \Omega, V_s = 6 V$)	13
Figure 18.	Distortion vs. frequency ($R_L = 4 \Omega, V_s = 6 V$)	13
Figure 19.	Distortion vs. output power ($R_L = 8 \Omega, V_s = 6 V$)	14
Figure 20.	Distortion vs. frequency ($R_L = 8 \Omega, V_s = 6 V$)	14
Figure 21.	Supply voltage rejection vs. frequency	14
Figure 22.	Common mode rejection vs. frequency	14
Figure 23.	Total power dissipation and efficiency vs. output power ($R_L = 4 \Omega$)	14
Figure 24.	Power dissipation vs. average output power (audio program simulation, $R_L = 4 \Omega$)	14
Figure 25.	Power dissipation vs. average output power (audio program simulation, $R_L = 4 \Omega$ & $8 \Omega, V_s = 6 V$)	15
Figure 26.	Power dissipation vs. output power ($R_L = 4 \Omega$ & 8Ω , sine, $V_s = 6 V$)	15
Figure 27.	Multiwatt 11 (vertical) package mechanical drawing	16
Figure 28.	PowerSO-20 (slug-down) package mechanical drawing	18
Figure 29.	PowerSO-20 (slug-up) package mechanical drawing	20

1 Block diagram, test and application circuit

1.1 Block diagram

Figure 1. Block diagram

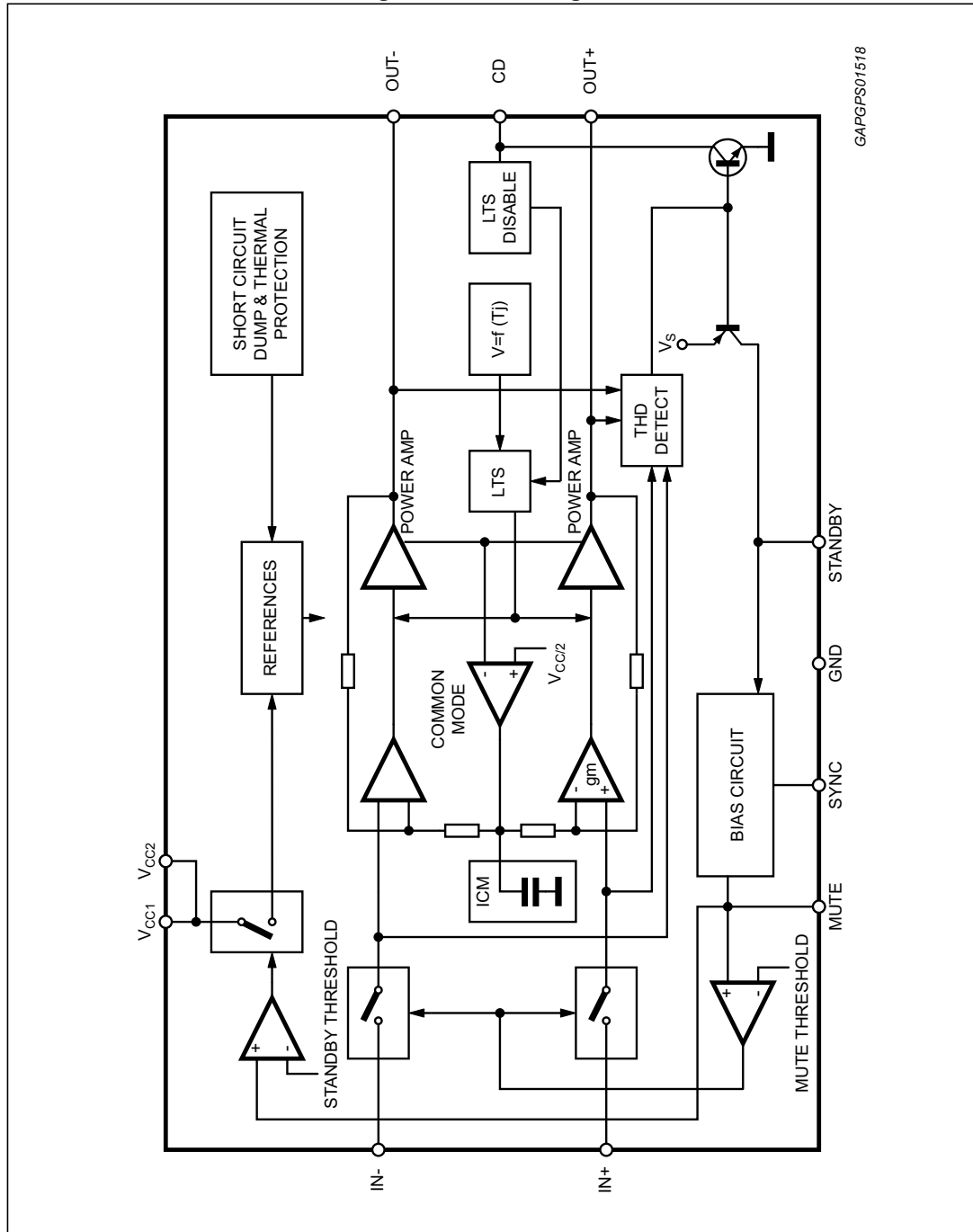

1.2 Test and application circuit

Figure 2. Test and application circuit

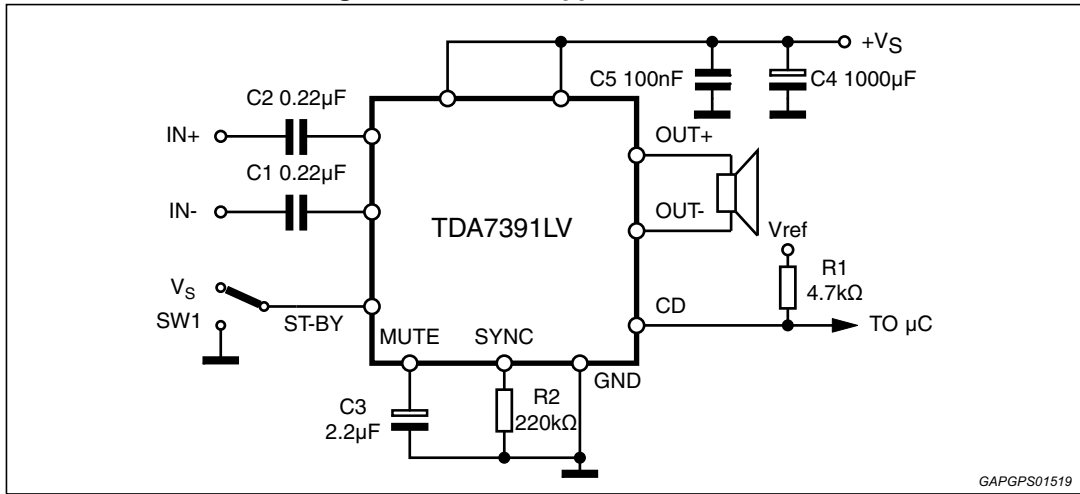

2 Pins description

Figure 3. Multiwatt 11 pins connection (top view)

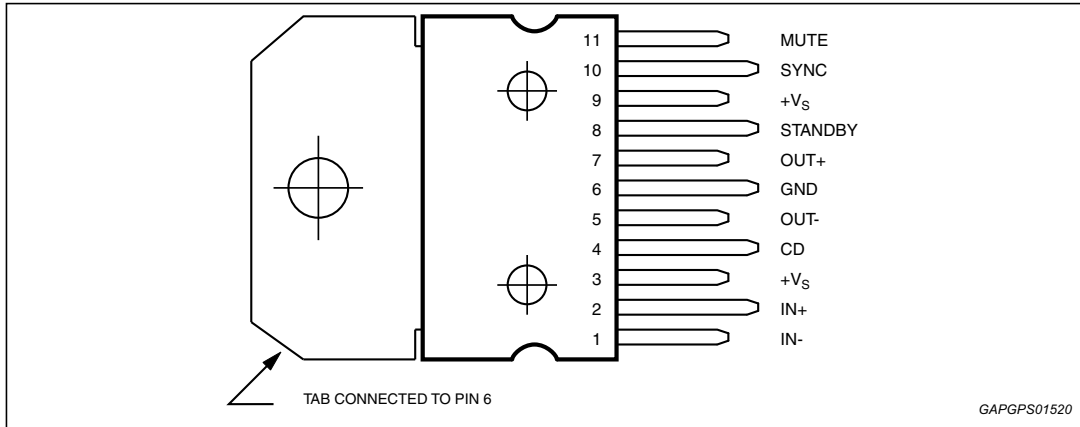

Figure 4. PowerSO-20 pins connection

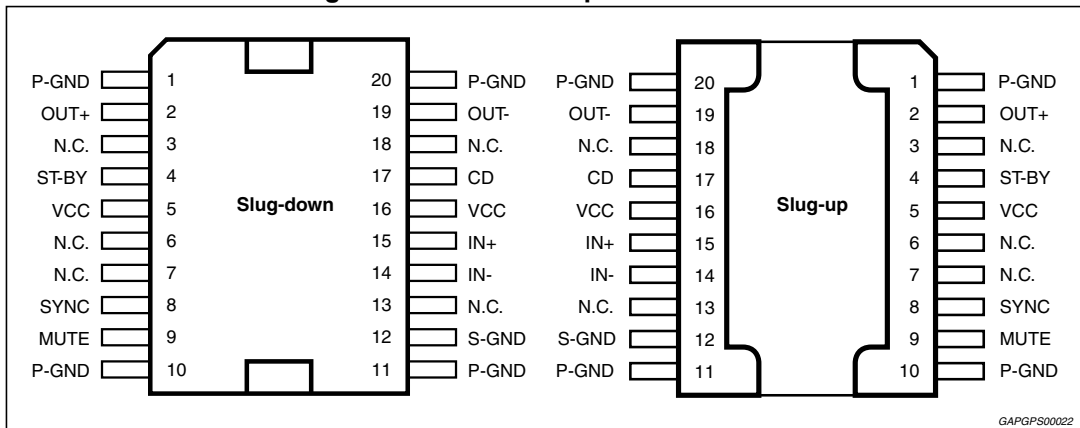

Table 2. Pins function

Multiwatt 11 Pin #	PowerSO-20 Pin #	Name	Description
1, 2	14, 15	INPUTS	The input stage is a high impedance type also capable of operation in single ended mode with one input capacitively coupled to the signal GND. The impedance seen by the inverting and non inverting input pins must be matched.
3, 9	5, 16	+V _S	Supply voltage.
4	17	CD	The TDA7391LV is equipped with a diagnostic circuitry able to detect the clipping in the Output Signal (distortion = 10%). The CD pin (open collector) gives out low level signal during clipping.

Table 2. Pins function (continued)

Multiwatt 11 Pin #	PowerSO-20 Pin #	Name	Description
5, 7	2, 19	OUTPUTS	The output stage is a bridge type able to drive loads as low as 3.2 Ω . It consists of two class AB fully complementary PNP/NPN stages fully protected. A rail to rail output voltage swing is achieved without need of bootstrap capacitors. No external compensation is necessary.
6	1, 10, 11, 20	GND	Power ground.
	12	S-GND	Signal ground.
8	4	STANDBY	The device features a standby function which shuts down all the internal bias supplies when the standby pin is low. In standby mode the amplifier sinks a small current (in the range of few μA). When the standby pin is high the IC becomes fully operational.
10	8	SYNC	A resistor (R_2) between pin 8 and GND set the charging current of capacitor C_3 (pin 9). The suggested values of C_3 and R_2 define the correct timing in order to switch on/off the amplifier without any pop noise.
11	9	MUTE	The pin is connected to a capacitor (C_3) tied to GND to set the mute/standby time. An automatic mute during turn on/off is provided to prevent noisy transients.

3 Electrical specifications

3.1 Absolute maximum ratings

Table 3. Absolute maximum ratings

Symbol	Parameter	Value	Unit
V_S	DC supply voltage	28	V
V_{OP}	Operating supply voltage	18	V
V_{PEAK}	Peak supply voltage (t = 50 ms)	50	V
I_O	Output peak current repetitive (f > 10 Hz)	4.5	A
	Output peak current non repetitive	6	A
P_{tot}	Power dissipation ($T_{case} = 85\text{ °C}$)	43	W
T_{stg}, T_j	Storage and junction temperature	-40 to 150	°C

3.2 Thermal data

Table 4. Thermal data

Symbol	Parameter	Multiwatt	PowerSO	Unit
$R_{th\ j-case}$	Thermal resistance junction-to-case Max.	1.8	2	°C/W

3.3 Electrical characteristics

$V_S = 14.4\text{ V}$; $R_L = 4\ \Omega$, $f = 1\text{ kHz}$, $T_{amb} = 25\text{ °C}$, unless otherwise specified.

Table 5. Electrical characteristics

Symbol	Parameter	Test condition	Min.	Typ.	Max.	Unit
V_S	Supply voltage range	-	6	-	18	V
I_q	Total quiescent current	-	-	60	150	mA
V_{OS}	Output offset voltage	-	-	-	120	mV
I_{SB}	Standby current	$V_{ST-BY} = 1.5\text{ V}$	-	-	50	μA
I_{SBin}	Standby input bias current	$V_{ST-BY} = 5\text{ V}$	-	-	10	μA
V_{SBon}	Standby on threshold voltage	-	-	-	1.5	V
V_{SBoff}	Standby off threshold voltage	-	3.5	-	-	V
ATT_{ST-BY}	Standby attenuation	-	-	90	-	dB
$I_{M\ in}$	Mute input bias current	($V_{MUTE} = 5\text{ V}$)	-	-	10	μA
A_M	Mute attenuation	-	-	90	-	dB

Table 5. Electrical characteristics (continued)

Symbol	Parameter	Test condition	Min.	Typ.	Max.	Unit
P_O	Output power	THD = 10 %	20	26	-	W
		THD = 1 %	-	21	-	W
		THD = 10 %; $R_L = 3.2 \Omega$	-	32	-	W
		$V_S = 6 \text{ V}$; THD = 10 %	-	4.2	-	W
$P_{O \text{ MAX}}$	Max. output power ⁽¹⁾	$V_S = 14.4 \text{ V}$; $R_L = 3.2 \Omega$	-	45	-	W
		$V_S = 6 \text{ V}$; THD = 10 %	-	6	-	W
THD	Total harmonic distortion	-	-	0.06	-	%
		$P_O = 0.1 \text{ to } 15 \text{ W}$	-	0.03	-	%
		$V_S = 6 \text{ V}$; $P_O = 1 \text{ W}$		0.05		%
		$V_S = 6 \text{ V}$; $P_O = 3.5 \text{ W}$		1.5		%
G_V	Voltage gain	-	29.5	30	30.5	dB
f_H	High frequency roll-off	$P_O = 1 \text{ W}$; -3 dB	75	-	-	kHz
R_{IN}	Input Impedance	Differential	36	60	-	k Ω
		Single ended	30	55	-	k Ω
E_{IN}	Input noise voltage	$R_g = 0 \Omega$; $f = 22 \text{ Hz to } 22 \text{ kHz}$	-	4	-	mV
CMRR	Input common mode rejection	$f = 1 \text{ kHz}$; $V_{IN} = 1 \text{ V}_{rms}$	-	65	-	dB
SVR	Supply voltage rejection	$R_g = 0 \Omega$; $V_r = 1 \text{ V}_{rms}$	-	60	-	dB
CDL	Clipping detection level	-	5	10	15	%
T_{sd}	Absolute thermal shutdown junction temperature	-	-	160	-	$^{\circ}\text{C}$

1. Saturated square wave output.

3.4 Low voltage operation ('start stop')

The most recent OEM specification are requiring automatic stop of car engine at traffic light, in order to reduce emissions of polluting substances. The TDA7391LV allows a continuous operation when battery falls down to 6/7 V during such conditions. The maximum system power will be reduced accordingly.

Worst case battery cranking curves are shown below, indicating the shape and durations of allowed battery transitions.

Figure 5. Worst case battery cranking curve sample 1

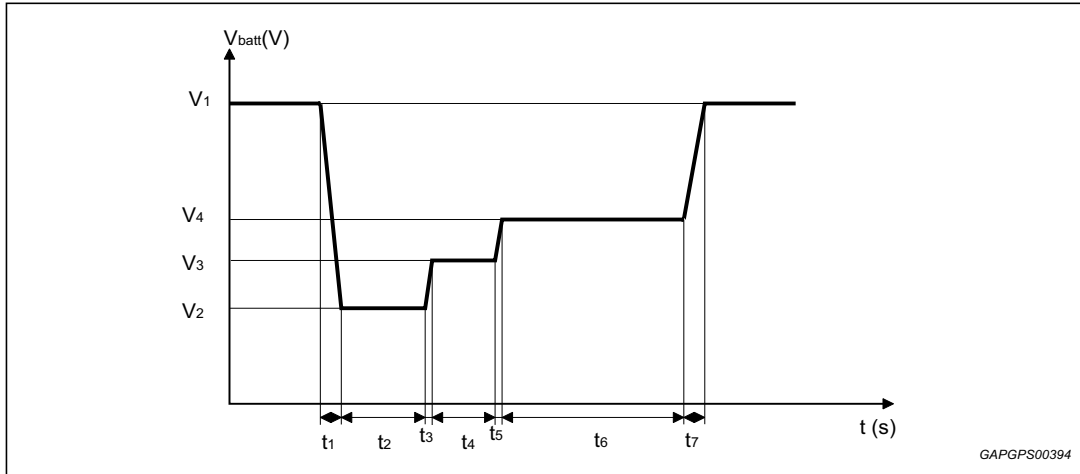

$V_1 = 12\text{ V}$; $V_2 = 6\text{ V}$; $V_3 = 7\text{ V}$; $V_4 = 8\text{ V}$

$t_1 = 2\text{ ms}$; $t_2 = 50\text{ ms}$; $t_3 = 5\text{ ms}$; $t_4 = 300\text{ ms}$; $t_5 = 10\text{ ms}$; $t_6 = 1\text{ s}$; $t_7 = 2\text{ ms}$

Figure 6. Worst case battery cranking curve sample 2

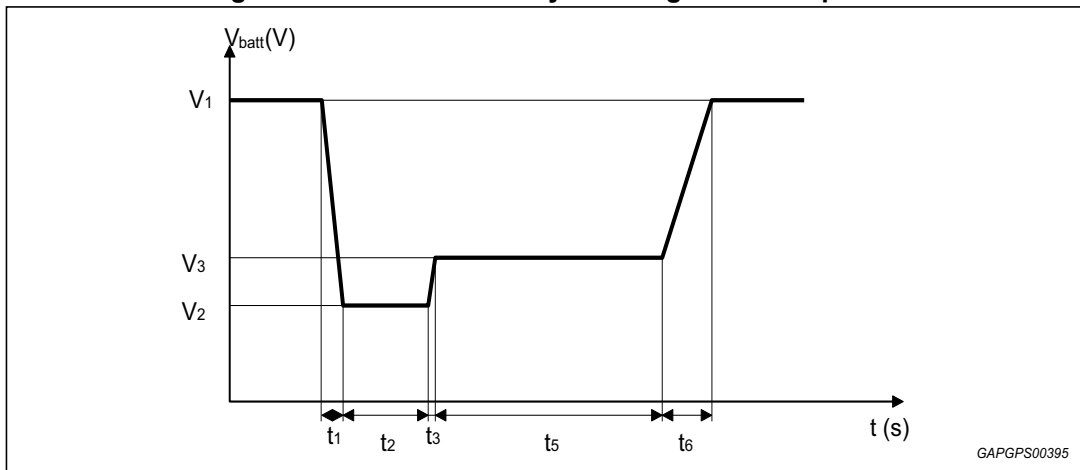

$V_1 = 12\text{ V}$; $V_2 = 6\text{ V}$; $V_3 = 7\text{ V}$

$t_1 = 2\text{ ms}$; $t_2 = 5\text{ ms}$; $t_3 = 15\text{ ms}$; $t_5 = 1\text{ s}$; $t_6 = 50\text{ ms}$

3.5 Electrical characteristics curves

Figure 7. Quiescent current vs. supply voltage

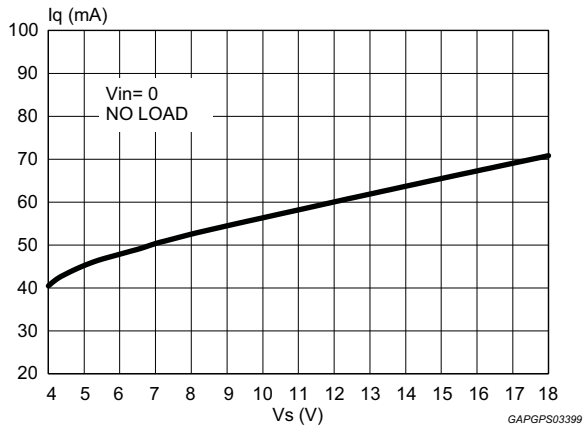

Figure 8. Output power vs. supply voltage ($R_L = 3.2 \Omega$)

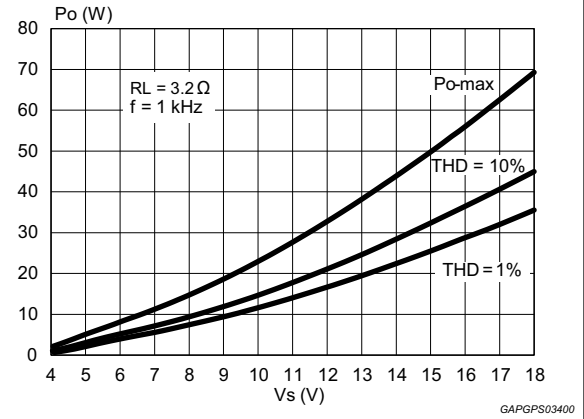

Figure 9. Output power vs. supply voltage ($R_L = 4 \Omega$)

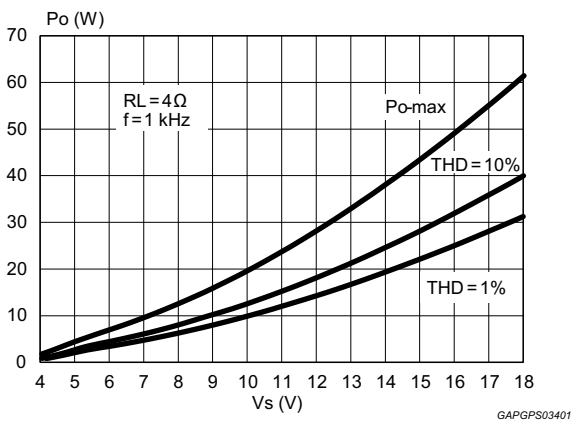

Figure 10. Output power vs. supply voltage ($R_L = 8 \Omega$)

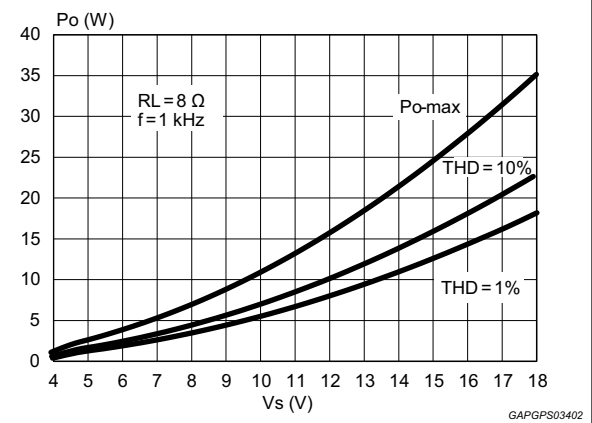

Figure 11. Distortion vs. output power ($R_L = 3.2 \Omega$)

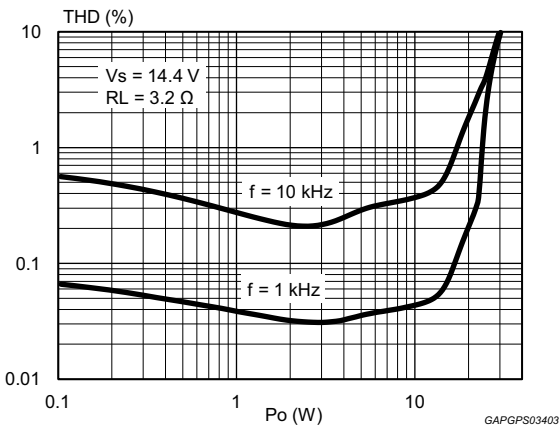

Figure 12. Distortion vs. frequency ($R_L = 3.2 \Omega$)

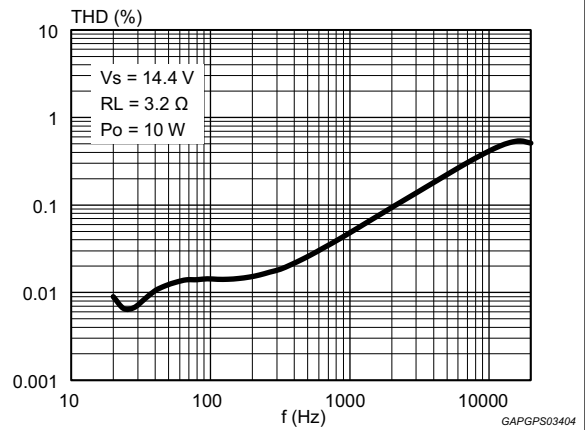

Figure 13. Distortion vs. output power ($R_L = 4 \Omega$)

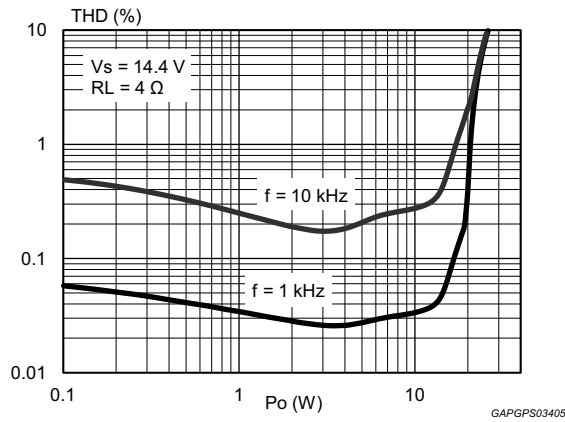

Figure 14. Distortion vs. frequency ($R_L = 4 \Omega$)

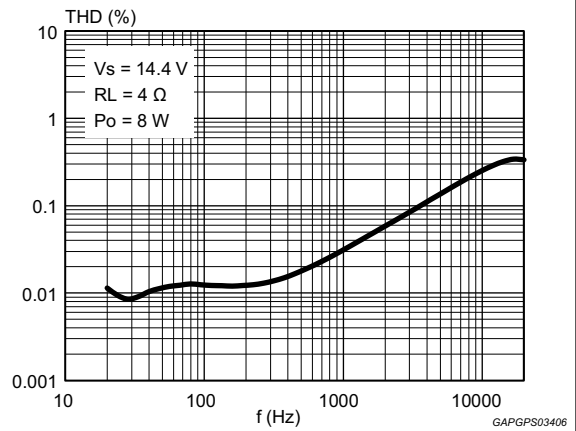

Figure 15. Distortion vs. output power ($R_L = 8 \Omega$)

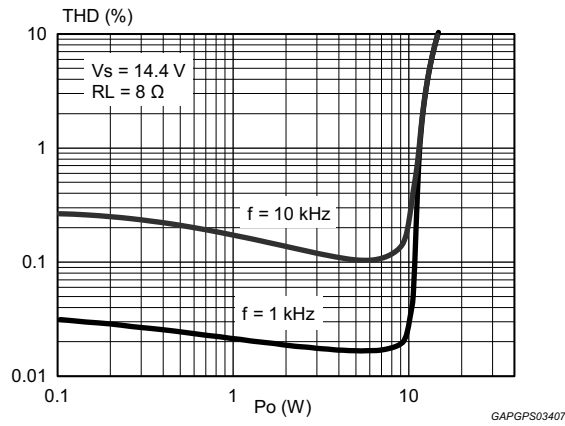

Figure 16. Distortion vs. frequency ($R_L = 8 \Omega$)

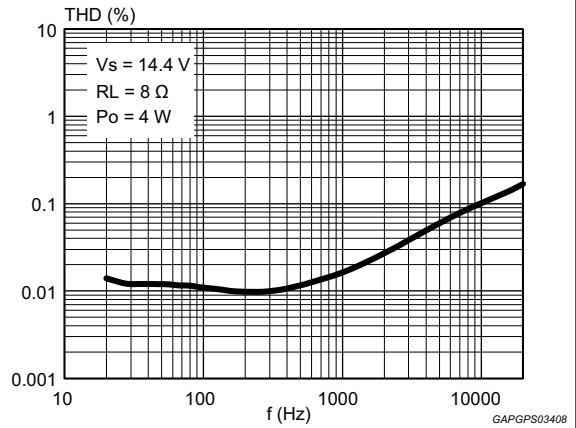

Figure 17. Distortion vs. output power ($R_L = 4 \Omega, V_s = 6 \text{ V}$)

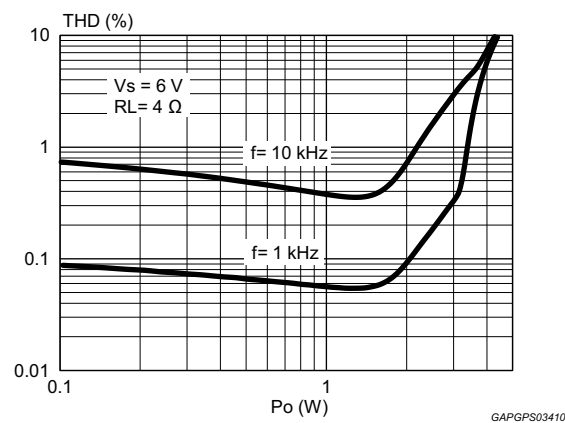
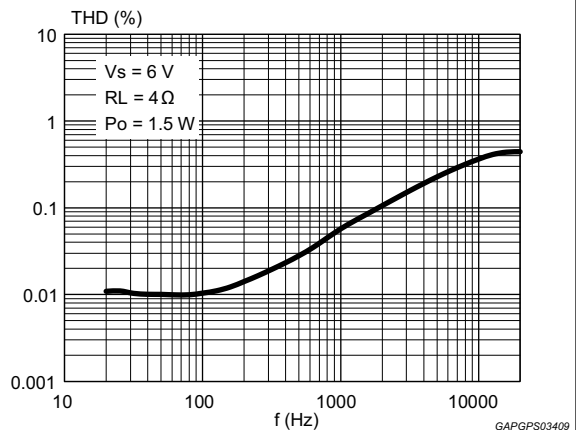

Figure 18. Distortion vs. frequency ($R_L = 4 \Omega, V_s = 6 \text{ V}$)



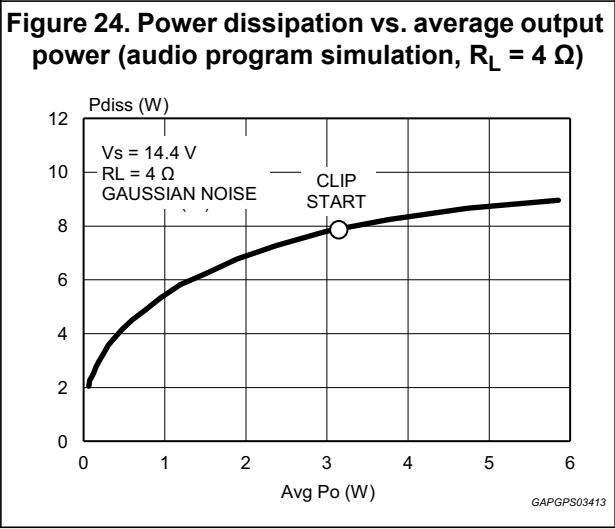
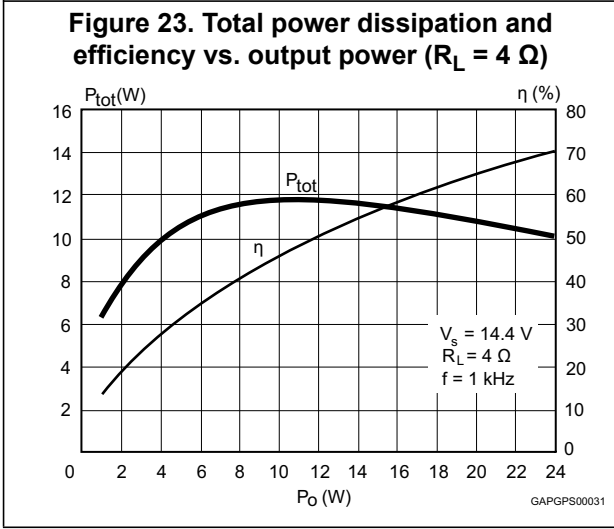
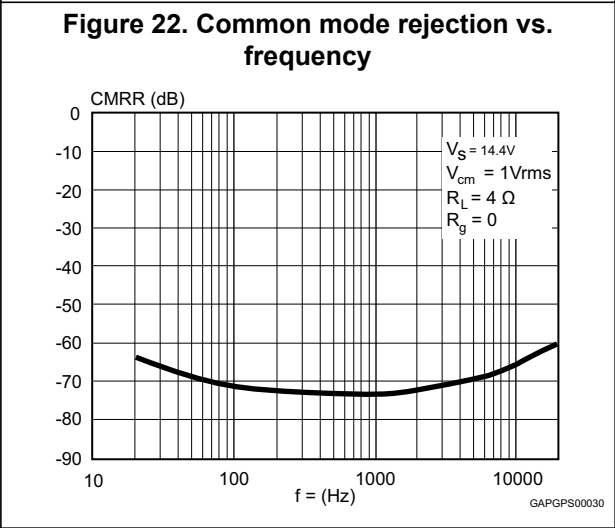
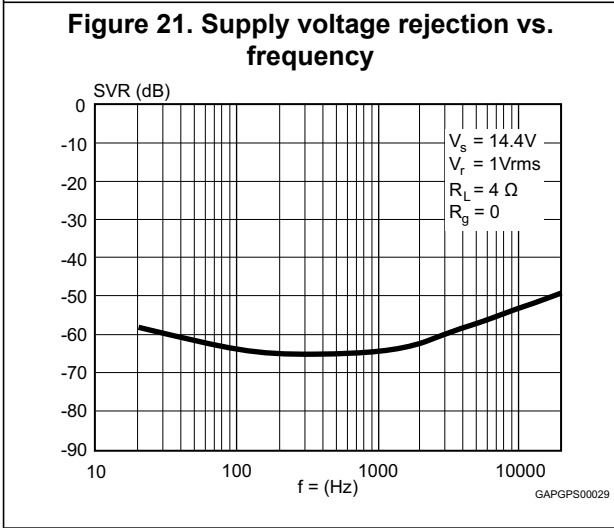
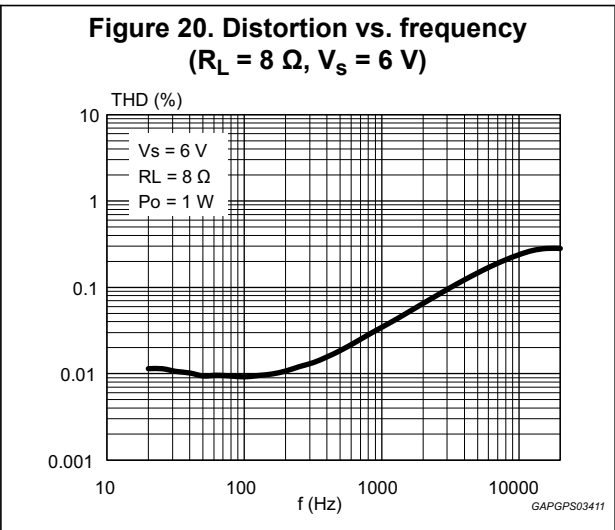
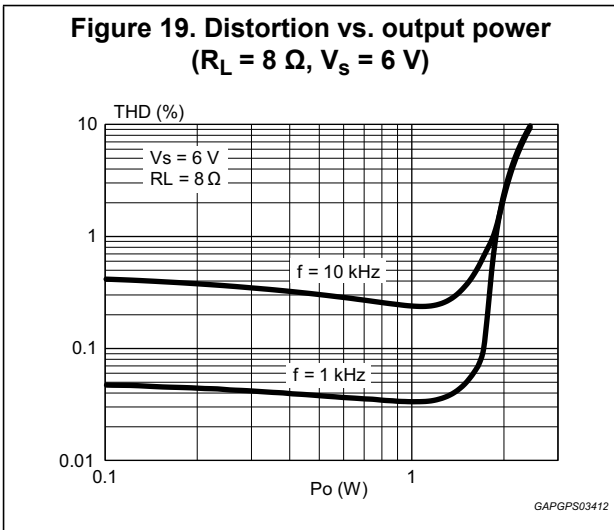

Figure 25. Power dissipation vs. average output power (audio program simulation, $R_L = 4 \Omega$ & 8Ω , $V_s = 6 V$)

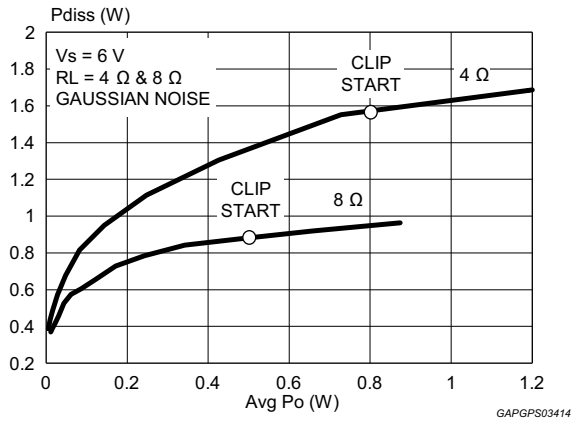
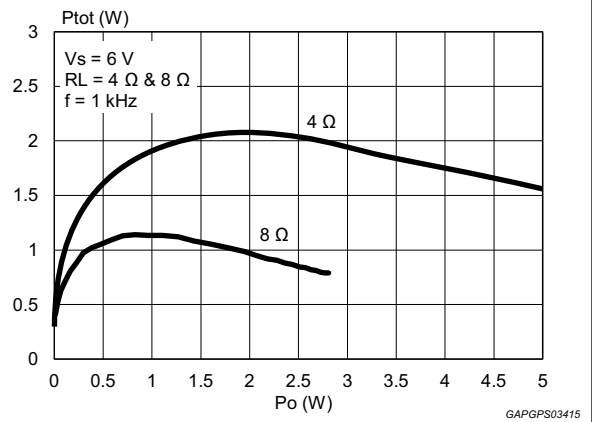

Figure 26. Power dissipation vs. output power ($R_L = 4 \Omega$ & 8Ω , sine, $V_s = 6 V$)



4 Package information

In order to meet environmental requirements, ST offers these devices in different grades of ECOPACK® packages, depending on their level of environmental compliance. ECOPACK® specifications, grade definitions and product status are available at: www.st.com.

ECOPACK® is an ST trademark.

4.1 Multiwatt 11 (vertical) package mechanical data

Figure 27. Multiwatt 11 (vertical) package mechanical drawing

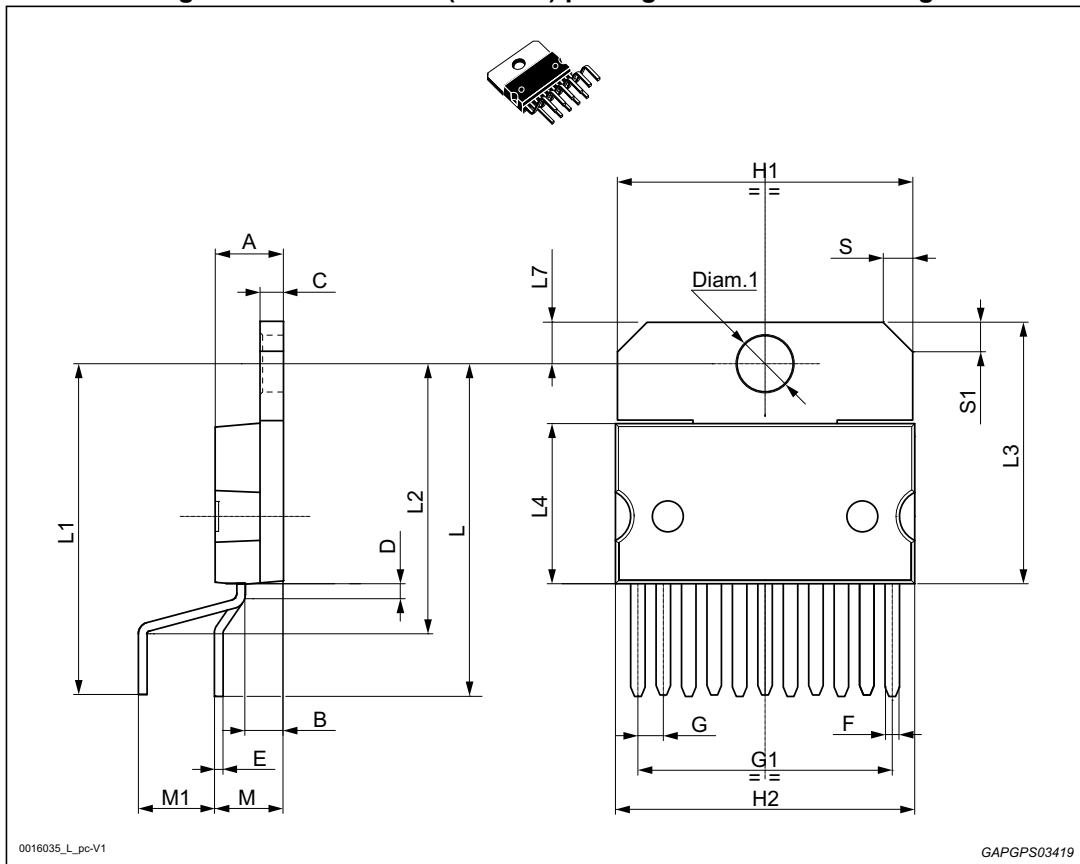

Table 6. Multiwatt 11 (vertical) package mechanical data

Symbol	Millimeters			Inches		
	Min.	Typ.	Max.	Min.	Typ.	Max.
A			5			0.1969
B			2.65			0.1043
C			1.6			0.063
D		1			0.0394	

Table 6. Multiwatt 11 (vertical) package mechanical data (continued)

Symbol	Millimeters			Inches		
	Min.	Typ.	Max.	Min.	Typ.	Max.
E	0.49		0.55	0.0193		0.0217
F	0.88		0.95	0.0346		0.0374
G	1.45	1.7	1.95	0.0571	0.0669	0.0768
G1	16.75	17	17.25	0.6594	0.6693	0.6791
H1	19.6			0.7717		
H2			20.2			0.7953
L	21.9	22.2	22.5	0.8622	0.874	0.8858
L1	21.7	22.1	22.5	0.8543	0.8701	0.8858
L2	17.4		18.1	0.685		0.7126
L3	17.25	17.5	17.75	0.6791	0.689	0.6988
L4	10.3	10.7	10.9	0.4055	0.4213	0.4291
L7	2.65		2.9	0.1043		0.1142
M	4.25	4.55	4.85	0.1673	0.1791	0.1909
M1	4.73	5.08	5.43	0.1862	0.2	0.2138
S	1.9		2.6	0.0748		0.1024
S1	1.9		2.6	0.0748		0.1024
Diam.1	3.65		3.85	0.1437		0.1516

4.2 PowerSO-20 (slug-down) package mechanical data

Figure 28. PowerSO-20 (slug-down) package mechanical drawing

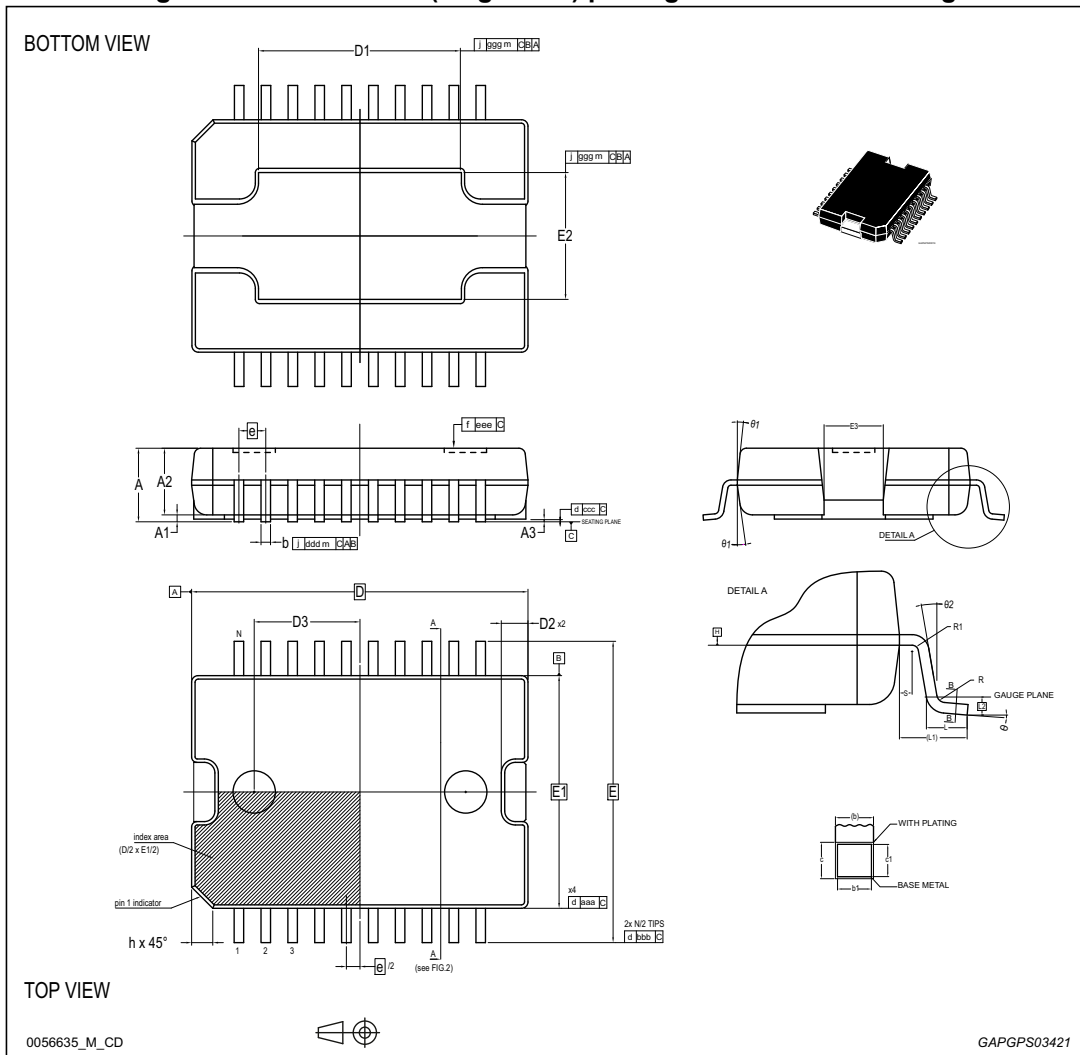

Table 7. PowerSO-20 (slug-down) package mechanical data

Symbol	Millimeters			Inches		
	Min.	Typ.	Max.	Min.	Typ.	Max.
θ	0°		8°	0°		8°
θ1	5°		10°	5°		10°
θ2	0°			0°		
A			3.6			0.1417
A1	0.1			0.0039		
A2	3	3.15	3.3	0.1181	0.124	0.1299
A3			0.1			0.0039

Table 7. PowerSO-20 (slug-down) package mechanical data (continued)

Symbol	Millimeters			Inches		
	Min.	Typ.	Max.	Min.	Typ.	Max.
b	0.4		0.53	0.0157		0.0209
b1	0.4	0.45	0.5	0.0157	0.0177	0.0197
c	0.23		0.32	0.0091		0.0126
c1	0.23	0.25	0.29	0.0091	0.0098	0.0114
D	15.90 BSC			0.626 BSC		
D1 ⁽¹⁾	9		13	0.3543		0.5118
D2			1.1			0.0433
D3		5			0.1969	
e	1.27 BSC			0.050 BSC		
E	14.20 BSC			0.5591 BSC		
E1 ⁽¹⁾	11.00 BSC			0.4331 BSC		
E2	5.6		6.2	0.2205		0.2441
E3			2.9			0.1142
h			1.1			0.0433
L	0.8		1.1	0.0315		0.0433
L1	1.60 REF			0.063 REF		
L2	0.35 BSC			0.0138 BSC		
N	20			0.7874		
R	0.2			0.0079		
R1	0.2			0.0079		
S	0.25			0.0098		
aaa	0.1			0.0039		
bbb	0.3			0.0118		
ccc	0.1			0.0039		
ddd	0.25			0.0098		
eee	0.1			0.0039		
ggg	0.25			0.0098		

1. Dimensions 'D' and 'E1' do not include mold flash or protrusions. Allowable mold flash or protrusions is "0.25 mm" per side D and "0.15 mm" per side E1. D and E1 are Maximum plastic body size dimensions including mold mismatch.

4.3 PowerSO-20 (slug-up) package mechanical data

Figure 29. PowerSO-20 (slug-up) package mechanical drawing

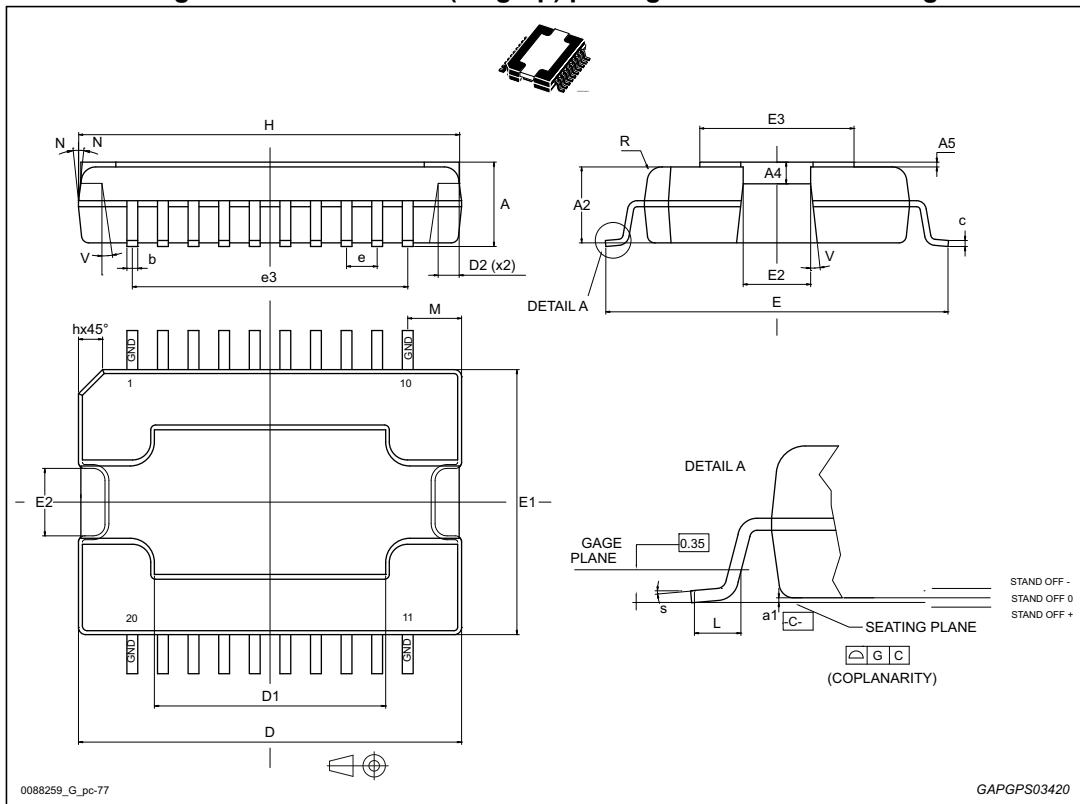

Table 8. PowerSO-20 (slug-up) package mechanical data

Symbol	Millimeters			Inches		
	Min.	Typ.	Max.	Min.	Typ.	Max.
A	3.25		3.5	0.128		0.1378
A2	3	3.15	3.3	0.1181	0.124	0.1299
a1	0.03		-0.04	0.0012		-0.0016
A4	0.8		1	0.0315		0.0394
A5	0.15	0.2	0.25	0.0059	0.0079	0.0098
b	0.4		0.53	0.0157		0.0209
c	0.23		0.32	0.0091		0.0126
D	15.8		16	0.622		0.6299
D1 ⁽¹⁾	9.4		9.8	0.3701		0.3858
D2		1			0.0394	
E	13.9		14.5	0.5472		0.5709
e	1.12	1.27	1.42	0.0441	0.05	0.0559
e3		11.43			0.45	

Table 8. PowerSO-20 (slug-up) package mechanical data (continued)

Symbol	Millimeters			Inches		
	Min.	Typ.	Max.	Min.	Typ.	Max.
E1 ⁽¹⁾	10.9		11.1	0.4291		0.437
E2			2.9			0.1142
E3	5.8		6.2	0.2283		0.2441
G	0		0.1	0		0.0039
h			1.1			0.0433
H	15.5		15.9	0.6102		0.626
L	0.8		1.1	0.0315		0.0433
N			10d.			10d.
R		0.6			0.0236	
s	0d.		8d.	0d.		8d.
V	5d.		7d.	5d.		7d.

1. 'D' and 'E1' do not include mold flash or protrusions.
Mold flash or protrusions shall not exceed 0.15 mm (0.006 inches) per side.

5 Revision history

Table 9. Document revision history

Date	Revision	Changes
29-Mar-2012	1	Initial release.
18-Sep-2013	2	Updated: <i>Features on page 1;</i> <i>Figure 1: Block diagram on page 5;</i> <i>Table 2: Pins function.</i> Updated disclaimer.
01-Dec-2014	3	Updated: <i>Features and Description on page 1;</i> <i>Table 5: Electrical characteristics</i> <i>Section 3.5: Electrical characteristics curves;</i> <i>Section 4: Package information.</i>

IMPORTANT NOTICE – PLEASE READ CAREFULLY

STMicroelectronics NV and its subsidiaries (“ST”) reserve the right to make changes, corrections, enhancements, modifications, and improvements to ST products and/or to this document at any time without notice. Purchasers should obtain the latest relevant information on ST products before placing orders. ST products are sold pursuant to ST’s terms and conditions of sale in place at the time of order acknowledgement.

Purchasers are solely responsible for the choice, selection, and use of ST products and ST assumes no liability for application assistance or the design of Purchasers’ products.

No license, express or implied, to any intellectual property right is granted by ST herein.

Resale of ST products with provisions different from the information set forth herein shall void any warranty granted by ST for such product.

ST and the ST logo are trademarks of ST. All other product or service names are the property of their respective owners.

Information in this document supersedes and replaces information previously supplied in any prior versions of this document.

© 2014 STMicroelectronics – All rights reserved

Компания «Океан Электроники» предлагает заключение долгосрочных отношений при поставках импортных электронных компонентов на взаимовыгодных условиях!

Наши преимущества:

- Поставка оригинальных импортных электронных компонентов напрямую с производств Америки, Европы и Азии, а так же с крупнейших складов мира;
- Широкая линейка поставок активных и пассивных импортных электронных компонентов (более 30 млн. наименований);
- Поставка сложных, дефицитных, либо снятых с производства позиций;
- Оперативные сроки поставки под заказ (от 5 рабочих дней);
- Экспресс доставка в любую точку России;
- Помощь Конструкторского Отдела и консультации квалифицированных инженеров;
- Техническая поддержка проекта, помощь в подборе аналогов, поставка прототипов;
- Поставка электронных компонентов под контролем ВП;
- Система менеджмента качества сертифицирована по Международному стандарту ISO 9001;
- При необходимости вся продукция военного и аэрокосмического назначения проходит испытания и сертификацию в лаборатории (по согласованию с заказчиком);
- Поставка специализированных компонентов военного и аэрокосмического уровня качества (Xilinx, Altera, Analog Devices, Intersil, Interpoint, Microsemi, Actel, Aeroflex, Peregrine, VPT, Syfer, Eurofarad, Texas Instruments, MS Kennedy, Miteq, Cobham, E2V, MA-COM, Hittite, Mini-Circuits, General Dynamics и др.);

Компания «Океан Электроники» является официальным дистрибьютором и эксклюзивным представителем в России одного из крупнейших производителей разъемов военного и аэрокосмического назначения «JONHON», а так же официальным дистрибьютором и эксклюзивным представителем в России производителя высокотехнологичных и надежных решений для передачи СВЧ сигналов «FORSTAR».



JONHON

«JONHON» (основан в 1970 г.)

Разъемы специального, военного и аэрокосмического назначения:

(Применяются в военной, авиационной, аэрокосмической, морской, железнодорожной, горно- и нефтедобывающей отраслях промышленности)

«FORSTAR» (основан в 1998 г.)

ВЧ соединители, коаксиальные кабели, кабельные сборки и микроволновые компоненты:

(Применяются в телекоммуникациях гражданского и специального назначения, в средствах связи, РЛС, а так же военной, авиационной и аэрокосмической отраслях промышленности).



Телефон: 8 (812) 309-75-97 (многоканальный)

Факс: 8 (812) 320-03-32

Электронная почта: ocean@oceanchips.ru

Web: <http://oceanchips.ru/>

Адрес: 198099, г. Санкт-Петербург, ул. Калинина, д. 2, корп. 4, лит. А