

H-bridge Gate Driver with LIN Transceiver, Watchdog, and 5V Regulator

1. Introduction

The Atmel® ATA6823 is designed specifically for automotive applications that require high-power motors. It provides four high-current gate driver outputs capable of driving a wide range of n-channel power MOSFETs in a full-bridge configuration. A fully integrated charge pump with external capacitors provides the gate voltage for the high-side output stages.

The Atmel® ATA6823 supports low-speed LIN-data communication up to 20kBaud in compliance with LIN specification 2.0 using a built-in LIN transceiver. Protection features include undervoltage/overvoltage detection and shutdown, overtemperature shutdown, and short circuit detection of motor leads to battery voltage and to ground. Shoot-through protection is guaranteed using a dead-time adjustment which can be set by hardware.

2. Application Board

The Atmel® ATA6823 application board allows the running of a DC motor. The supply voltage is 8V to 18V, maximum power of the DC motor is limited by the external H-bridge MOSFETs. No microcontroller is implemented on-board. It is possible to control the motor either via an external microcontroller (with or without LIN bus), or directly (using the DIR and PWM pins).

2.1 Features

- Header Pins X1 to Connect to LIN Bus as well as Power Supply Output and EN2 Wake-up (See [Table 2-1 on page 6](#))
- Microcontroller Connector Interface (See [Table 2-2 on page 6](#))
- 4-mm Banana Plugs to Connect Power Supply BAT and GND (See [Figure 2-2 on page 3](#))
- Included Power DC Motor On-board, Turn Direction Indicated by LEDs
- Vias M+ and M- to Connect Optional DC Motor
- Optional Connection of External Motor H-bridge (See [Figure 2-6 on page 8](#))
- Push-button EN2 to Wake-up Atmel ATA6823
- Jumper VMODE to Select VCC Output Voltage Level
- Jumper RWD to Select Different WD Resistors
- Shunt for DC Motor Current Measurement



Atmel ATA6823 H-bridge Gate Driver with LIN Transceiver, Watchdog and 5V Regulator

Application Note



Figure 2-1. Application Board

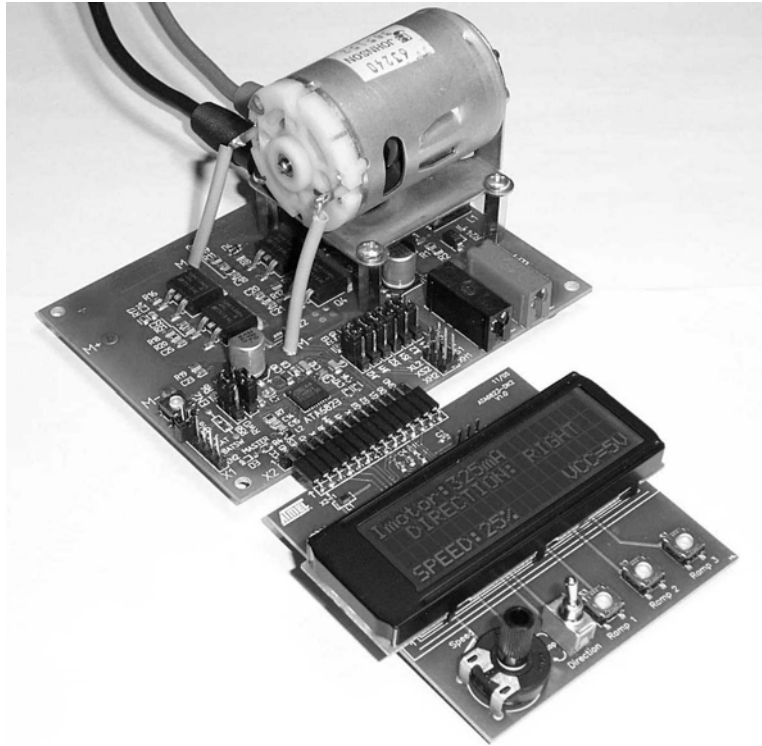

Figure 2-2. Atmel® ATA6823 Application Board Schematic

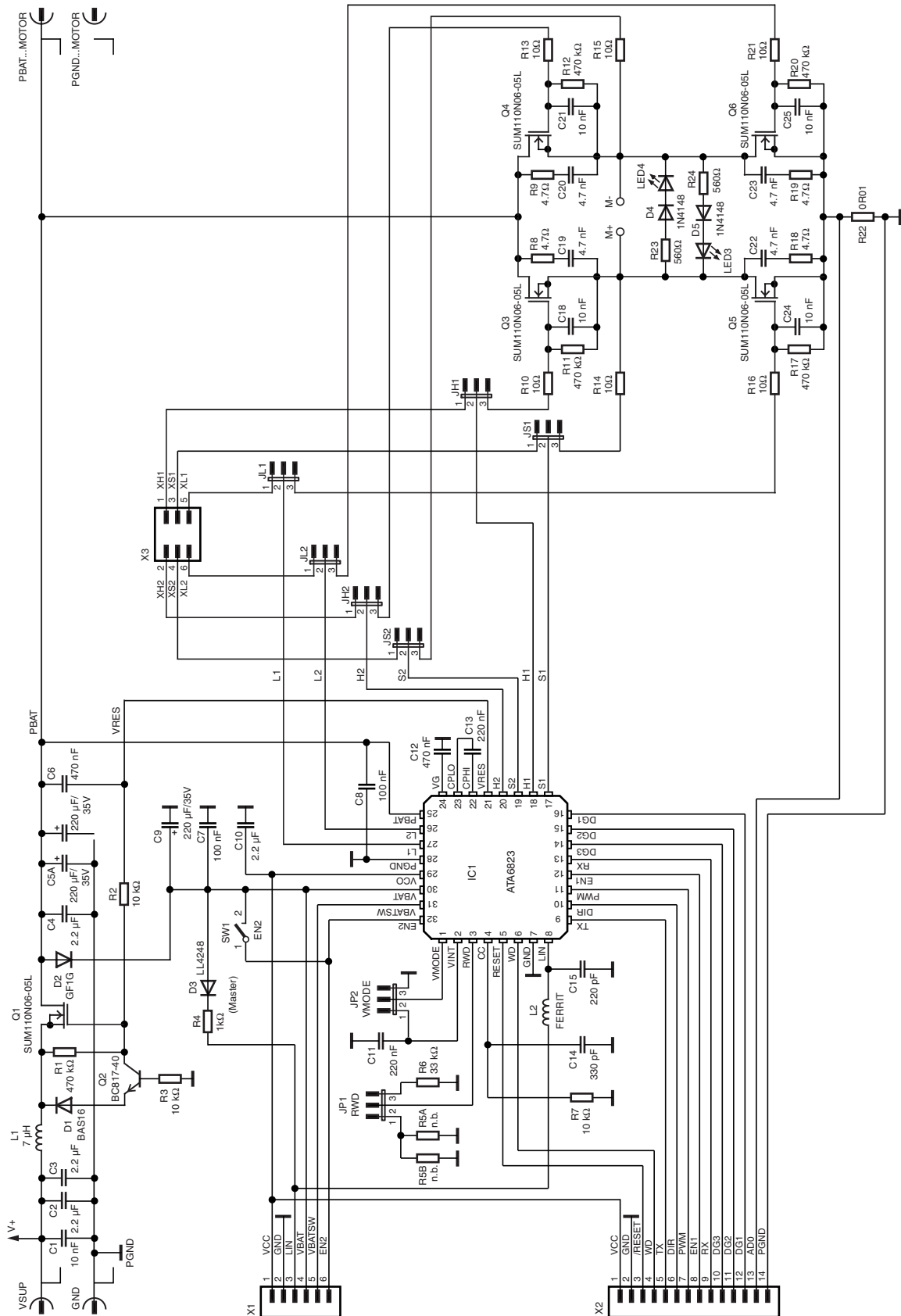

Figure 2-3. Atmel® ATA6823 Application Board Component Placement; Top Side, Top View

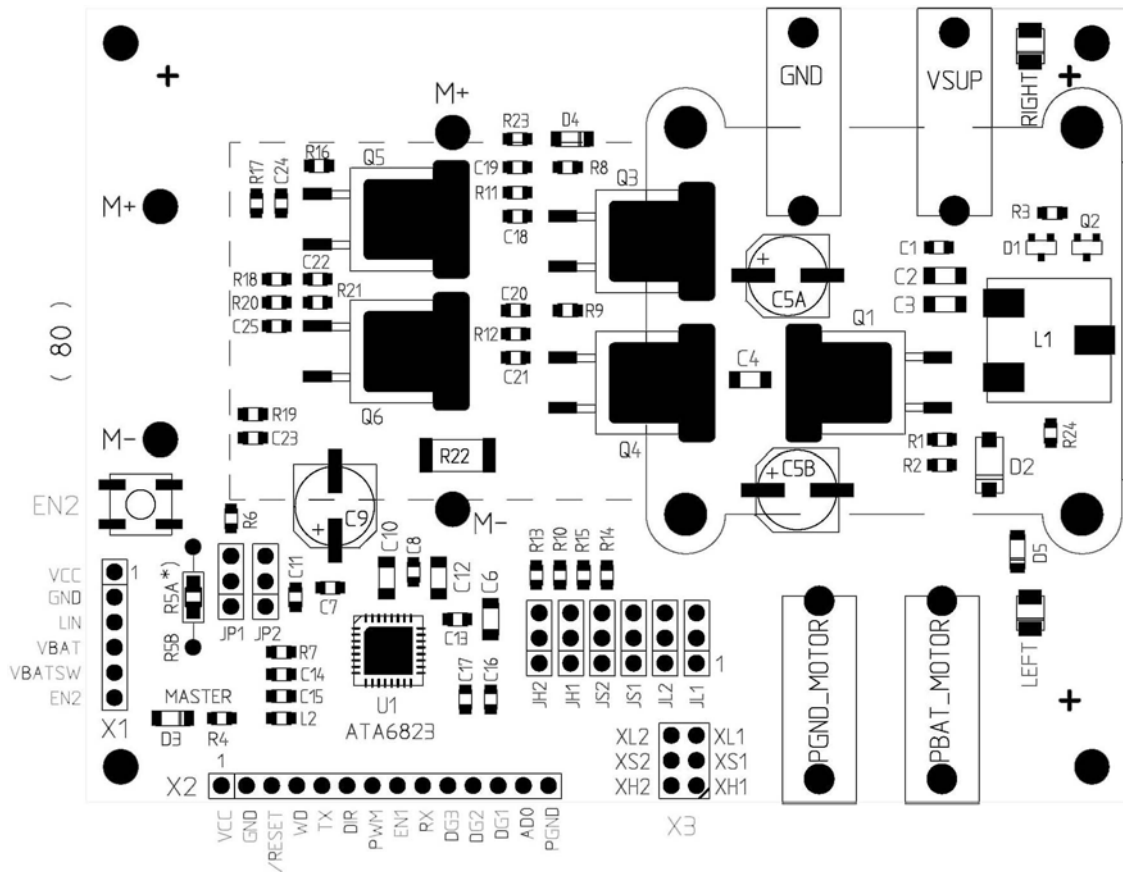

Figure 2-4. Atmel® ATA6823 Application Board; Top Side, Top View

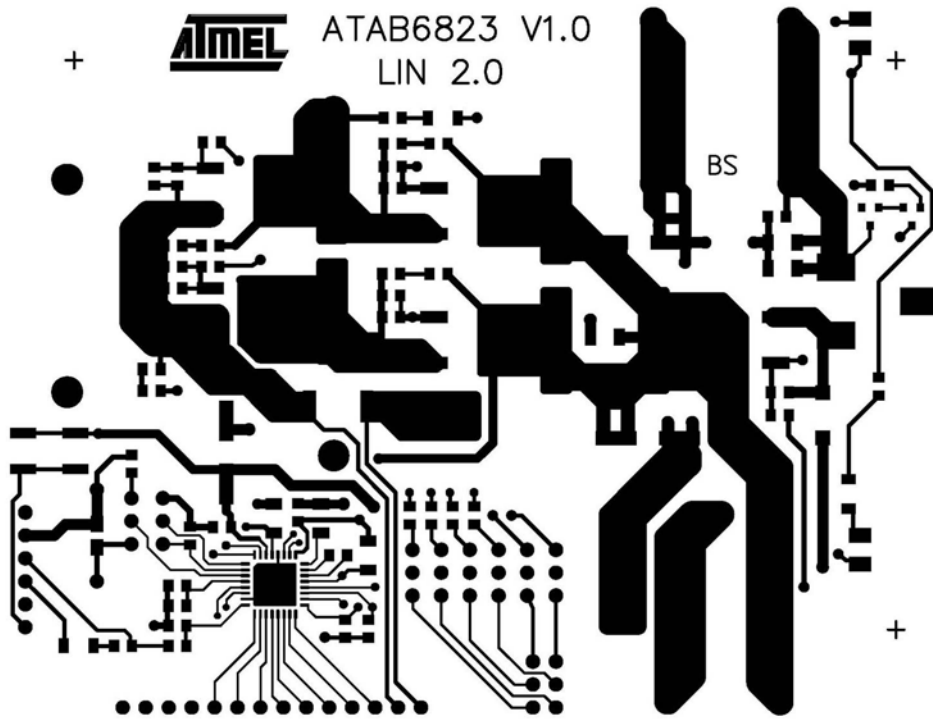

Figure 2-5. Atmel ATA6823 Application Board; Bottom Side, Top View (as if PCB Were Transparent)

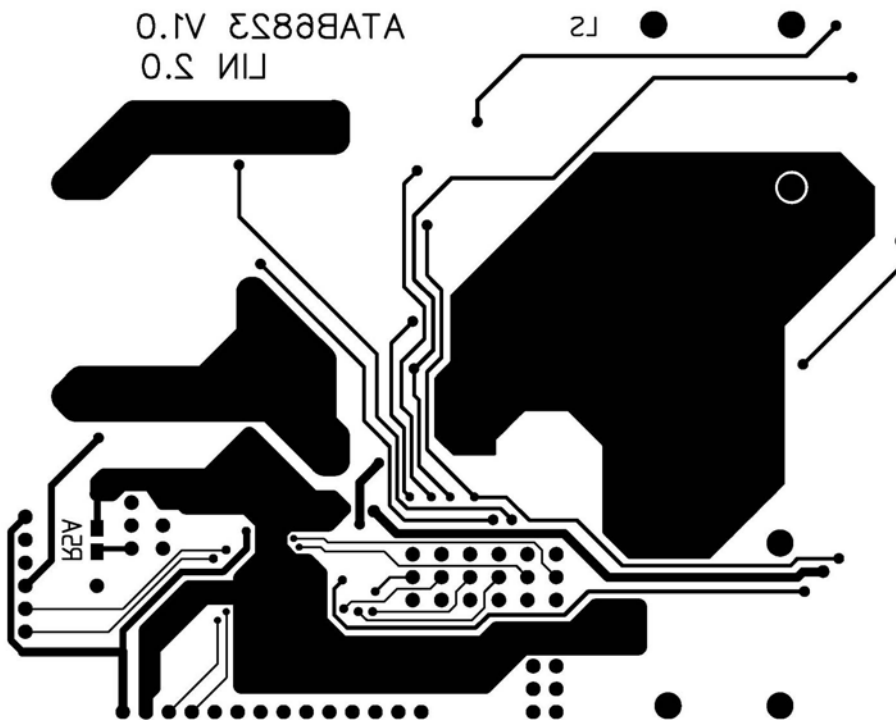

Table 2-1. X1 LIN Header Pins

Pin	Symbol	Description
1	VCC	VCC regulator output, voltage level depends on jumper JP2 setting
2	GND	Ground for chip core
3	LIN	LIN bus terminal
4	VBAT	Atmel ATA6823 supply voltage
5	VBATSW	100Ω PMOS switch from VBAT
6	EN2	Enable input, 12V logic

Table 2-2. X2 Microcontroller Interface Header Pins

Pin	Symbol	Direction	Description
1	VCC	Out	VCC regulator output, voltage level depends on jumper JP2 setting
2	GND	-	Ground for chip core
3	/RES	Out	Microcontroller reset
4	WD	In	Watchdog trigger signal
5	TX	In	Transmit signal to LIN bus from microcontroller
6	DIR	In	Defines the rotation direction of the motor
7	PWM	In	PWM input controls motor speed
8	EN1	In	Keeps the chip in ACTIVE mode via the microcontroller
9	RX	Out	Receive signal from LIN bus to microcontroller
10	DG3	Out	Diagnostic output 3
11	DG2	Out	Diagnostic output 2
12	DG1	Out	Diagnostic output 1
13	AD0	Out	Upper level of motor current shunt
14	PGND	Out	Lower level of motor current shunt, GND sense level

Table 2-3. X3 ATA6823 Motor Bridge Interface

Pin	Symbol	Description
1	XL2	Atmel ATA6823 pin 26, L2 output to control external H-bridge
2	XL1	Atmel ATA6823 pin 27, L1 output to control external H-bridge
3	XS2	Atmel ATA6823 pin 19, S2 output to control external H-bridge
4	XS1	Atmel ATA6823 pin 17, S1 output to control external H-bridge
5	XH2	Atmel ATA6823 pin 20, H2 output to control external H-bridge
6	XH1	Atmel ATA6823 pin 18, H1 output to control external H-bridge

Table 2-4. Jumper Settings

Jumper	Symbol	Description
1	RWD	Watchdog resistor selection Upper position 2-3 selects R6 (default) Lower position 1-2 selects R5A + R5B R6 is implemented as 33kΩ (customer specific, depending on watchdog requirements)
2	VMODE	VCC regulator output level Upper position 2-3 = output level is 3.3V Lower position 1-2, set to "1" = output level is 5V (default)
3	JH2	Upper position 2-3 switches H2 to on-board H-bridge gate Q3 (default) Lower position 1-2 switches H2 to external connector X3 pin XH2
4	JH1	See JH2
5	JS2	Upper position 2-3 switches S2 to on-board H-bridge motor M- (default) Lower position, see JH2
6	JS1	Upper position 2-3 switches S2 to on-board H-bridge motor M+ (default) Lower position, see JH2
7	JL2	See JH2
8	JL1	See JH2

Table 2-5. Push Button

Push Button	Symbol	Function
1	EN2	It is possible to wake up the ATA6823 either by LIN or by push button EN2

2.2 Getting Started

To run the ATA6823 application board, a 8V to 18V supply voltage between VBAT and GND is necessary.

To check the board at start up, following voltages are measurable at 12.5V VBAT voltage.

After the power supply is switched on, a level of 5V is measurable at VINT and the header pin VCC; the VG voltage level is 12.5V and the charge pump voltage VRES is 26.5V. The voltage level at resistor RWD (R6, JP1) is 1.2V. The charge pump capacity (C13) voltage level is 5V. The charge pump oscillator frequency is approximately 100kHz.

If the watchdog signal is not applied to the pin WD, the pin /RESET oscillates with a frequency around 7Hz.

It is not possible to activate the H-bridge without providing a watchdog.

2.3 External H-bridge

Figure 2-6. External H-bridge Connection

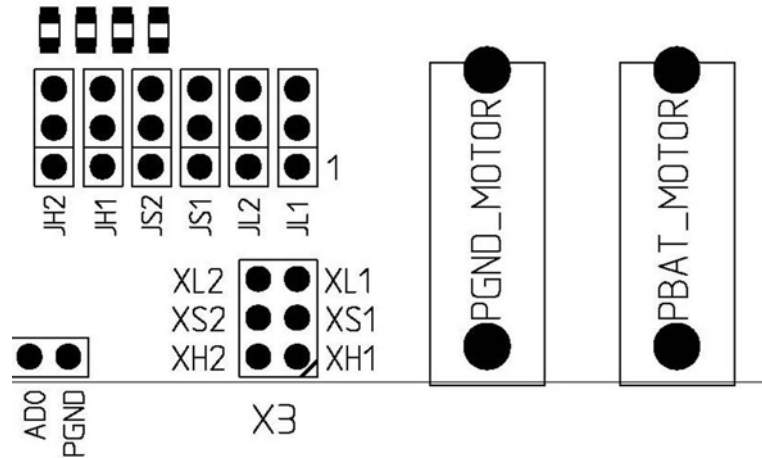

The application board offers the possibility of an external H-bridge connection (see [Figure 2-6](#)).

The external H-bridge can be supplied by the 4-mm banana plugs PBAT_MOTOR and PGND_MOTOR.

The gate driver and sense pins are available via header pin connector X3 (see [Table 2-3 on page 6](#)). To change between the on-board H-bridge and the external H-bridge, jumpers JH2 to JL1 (see [Table 2-4 on page 7](#)) have to be changed to lower position 1-2.

2.4 LIN Mode

Figure 2-7. LIN Master Option



According to LIN specification 2.0, resistor R4 is not necessary when using the Atmel[®] ATA6823 as slave. This is the default at delivery.

To change the Atmel ATA6823 LIN from slave mode to master mode, complying with LIN specification 2.0, a 1k Ω resistor has to be inserted in place of R4, and reverse battery protection diode has to be inserted in place of D3.

2.5 Microcontroller Integration

To run the H-bridge, it is necessary to attend the Watchdog and Pace signal. To operate, a microcontroller can be connected via the header pins X2 (see [Table 2-2 on page 6](#)). All pins which can be connected to the microcontroller are available on the header pins X2:

- Voltage supply VCC
- LIN interface
- Watchdog
- Motor control PWM and DIR
- LIN transceiver
- Diagnostic pins

The VCC voltage level can be chosen by the jumper VMODE (see [Table 2-4 on page 7](#)).

2.6 Current Shunt

Shunt R22 is available to monitor the H-bridge current. The sense lines AD0 and PGND (see [Table 2-2 on page 6](#)) of the shunt can be connected to the AD converter of the microcontroller.

Figure 2-8. Watchdog Resistor Placement

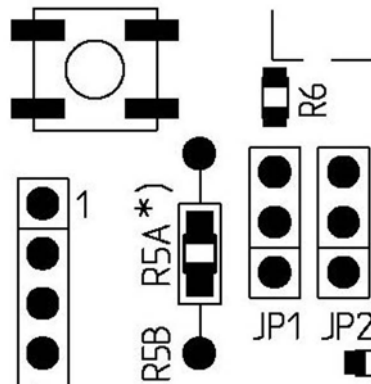

2.7 Watchdog Resistor RWD

Upper jumper RWD position 2-3 selects the standard watchdog resistor value R6 33kΩ

Optionally, the watchdog frequency can be changed via resistor R5, by setting jumper RWD to position 1-2. Either SMD (R5A) or wired (R5B) resistors may be used.

3. Application Hints

3.1 Trigger Watchdog

To switch Atmel® ATA6823 into operating mode, it is necessary to apply a correct trigger signal to the pin WD. If $R6 = R_{WD} = 33k\Omega$, a square wave trigger signal of $f = 70Hz$ is required. To adapt the resistor to other values, refer to the datasheet for Atmel® ATA6823, especially the section title Reset and Watchdog Management.

The trigger signal has no integrated debouncing circuit. It switches with a rising edge at pin WD.

Operating mode is shown by permanently high level at pin /RESET.

A wrong or missing trigger pulse generates a reset pulse with length of 2ms. VCC voltage lower than the reset threshold generates a reset pulse for 68ms.

3.2 Enable

After power-on, the Atmel ATA6823 is in run mode. A falling edge at pin EN1 switches the device to standby mode.

Switching Atmel ATA6823 back to run mode is possible either by switching LIN to GND or by switching EN2 to VBAT.

EN2 can be switched up to VBAT. EN1 uses 5V logic and would be destroyed by switching to the VBAT level.

3.3 Wake-up Source Recognition

Diagnostic pin DG1 has a double assignment: Until the first watch dog pulse, DG1 shows the wake up source; a high level at pin DG1 indicates that EN2 is the wake-up source, while a low level indicates LIN was wake-up source.

Table 3-1. Diagnostic Pins

Signal	Description
DG1	Short circuit
DG2	Supply monitoring, charge pump
DG3	Overtemperature warning

3.4 Diagnostic Pins

There are three diagnostic pins available to detect errors (see [Table 3-1 on page 10](#)).

The Atmel ATA6823 has neither short-circuit shutdown nor short-circuit limitation. Short circuit is indicated, handling must be done by the microcontroller.

While the outputs are switched on, the voltage levels between the active MOSFET sources and drains are monitored. If one voltage level is higher than 4V, DG1 will be set to high. After switching the motor bridge, either by PWM or by DIR, the sense monitoring is deactivated for 10µs. Otherwise inrush or switching currents will activate the DG1 warning.

Supply voltage breakdown at pin PBAT under the level of 5.6V is indicated by a high level at pin DG1, without any delay time.

The intent is to monitor a dedicated H-bridge power supply.

An overvoltage or undervoltage condition at pin VBAT will be indicated by a high level at the diagnostic pin DG2. To debounce, a 13-kHz low-pass filter is inserted.

Charge pump voltage lower than $V_{VBAT} + 4V$ will be indicated by DG2 set to high, with a debouncing time of 30 μ s.

If overtemperature of higher than 150°C is detected, the pin DG3 is set to high. The occurrence of overtemperature will be latched until the next watchdog pulse.

If monitoring signals DG2 or DG3 indicate failure, the ATA6823 will switch off the motor bridge.

3.5 Motor Bridge OFF

When the PWM signal is set to low, both high-side MOSFETs are switched on to slow the motor down. Cruise Control guarantees fly back currents over the contrary highside N-MOSFET.

3.6 Inrush Current

Switching a motor load on immediately to 100% duty cycle causes a voltage drop due to the inrush current. This drop depends on the power supply installation. Depending on the level of voltage drop, the Atmel® ATA6823 detects short circuits as described below. A short and proper connection between the power supply and application board is essential.

Use the PWM feature when supplying powerful motors and limiting their starting current.

3.7 Output Short Circuit

Five different short circuit conditions need to be considered. In the following comments, a static motor clamp will be the clamp which is switched to VBAT. This high-side switch is not PWM controlled, it is permanently on. Dynamic motor clamp will be the low-side clamp switch to GND, which is controlled by PWM.

1. Short between both motor clamps

In an ideal short circuit, 2 output switches and 1 inverse polarity protection switch are in serial. In this case, R_{dsON} and supply voltage higher than 12V short circuit will be detected by pin S1 or S2: One of the two drain source voltage drops of the output FETs is higher than 4V and will switch DG1 on.

If the supply voltage is lower than 12V or the short circuit is not ideal (that is, the drain source voltage drop over both output switches is lower than 4V each) the reservoir capacitor will be discharged. Voltage monitoring at PBAT will set DG1. The PBAT voltage monitoring also will detect failure if PWM duty cycle time is shorter than 10 μ s, because 10 μ s is the delay time until short circuit detection.

2. Short between static motor clamp and ground

For an ideal short circuit and supply voltage higher than 8V, minimum one of the output drops is higher than 4V. The sense pin S1 or S2 will switch the pin DG1.

In all other cases, PBAT monitoring will switch DG1, if PBAT falls below 5.6V.

3. Short between dynamic clamp (PWM) and ground
 For an ideal short circuit, supply voltage higher than 8V and ON duty cycle higher than 10 μ s, the sense pin S1 or S2 will switch the pin DG1.
 For non-ideal short circuit or lower supply voltages, PBAT monitoring will switch DG1.
 There is an 18V zener diode between Hx and Sx. In case of higher supply voltages and short between dynamic clamp and GND, the charge pump capacity will be discharged over this 18V clamping structure. If voltage at VRES minus voltage at PBAT is lower than 5V, after 30 μ s, DG2 will be set and the output switches will be switched off.
4. Short between dynamic clamp and supply pin PBAT after inverse polarity protection
 For an ideal short circuit, supply voltage higher than 8V and ON duty cycle higher than 10 μ s causes a voltage drop higher than 4V at least across output FET. The sense pins S1 or S2 will switch the pin DG1.
 During other conditions, PBAT monitoring will switch DG1.
5. Short between dynamic clamp and supply before inverse polarity protection
 For ON duty cycle higher than 10 μ s, sense pin S1 or S2 will switch pin DG1.
 A short circuit cannot be detected with the diagnostic pins of the Atmel[®] ATA6823 for a duty cycle shorter than 10 μ s. Usually the motor will not move, and the servo loop will signal deadlock.

4. Add-on Microcontroller Module to Generate WD and PWM

The WD and PWM signals are necessary to activate the Atmel ATA6823 H-bridge as shown in [Table 2-2 on page 6](#). Therefore, the microcontroller module ([Figure 4-1 on page 14](#), Atmel ATA6823-DK2 V1.0), assembled with Atmel ATmega88, is included. The module works with both Atmel ATA6823 digital supply voltages, 5V as well as 3.3V.

Table 4-1. Add-on Module Operating Elements

Type	Name	Function
Push button	Ramp1	Start ramp release DG1 signals: short circuit
Push button	Ramp2	Stop ramp release DG2 signals: charge pump, overvoltage/undervoltage detection
Push button	Ramp3	Switch system into sleep mode
Switch	Direction	Left – Off – Right
Potentiometer	Speed	PWM frequency

4.1 Watchdog

The module generates a trigger signal of approximately $f_{WD} = 70\text{Hz}$, which is required in case of the default watchdog resistor $R_{WD} = R6 = 33\text{k}\Omega$.

4.2 PWM

The module also provides the PWM signal with duty cycle from 0% to 100%, adjustable by speed potentiometer (see [Table 4-1](#)). The PWM frequency of the example program is $f_{\text{PWM}} = 25\text{kHz}$.

4.3 Operating Functions

The microcontroller module is turnable via operating elements as described in [Table 4-1 on page 12](#).

Two different operating modes are available:

1. Manual mode:

Rotation direction is selected using the direction switch, and the generated PWM frequency responds to the PWM potentiometer.

2. Automatic ramp mode:

Pressing push button Ramp1 causes a triangle-duty-cycle PWM curve to be generated. The low value is zero, the maximum value is the set value of the speed potentiometer. The ramp will be stopped by pressing push button Ramp2.

4.4 Sleep Mode

Push button Ramp3 is defined to switch Atmel® ATA6823 into standby mode. The microcontroller will no longer be supplied with VCC voltage.

System wake-up can only be triggered by Atmel ATA6823.

Either ground level on the LIN bus or push button EN2 wakes up the Atmel ATA6823. The controller is supplied again and begins to work.

4.5 Diagnosis

If a short circuit is indicated by diagnosis pin DG1, the microcontroller will switch off the H-bridge immediately. Turning it on again is locked. Push button Ramp1 controls the unlock function.

DG2 voltage diagnosis also causes the switching off of the gate driver. To release, use push button Ramp2.

Overtemperature DG3 warning is indicated in the display, the H-bridge stops.

The overtemperature signaling is not latched, after cooling down the signal disappears, the H-bridge starts running again.

Figure 4-1. Add-on Atmel® Atmega88 Module ATA6823-DK2 V1.0 for Generating WD and PWM

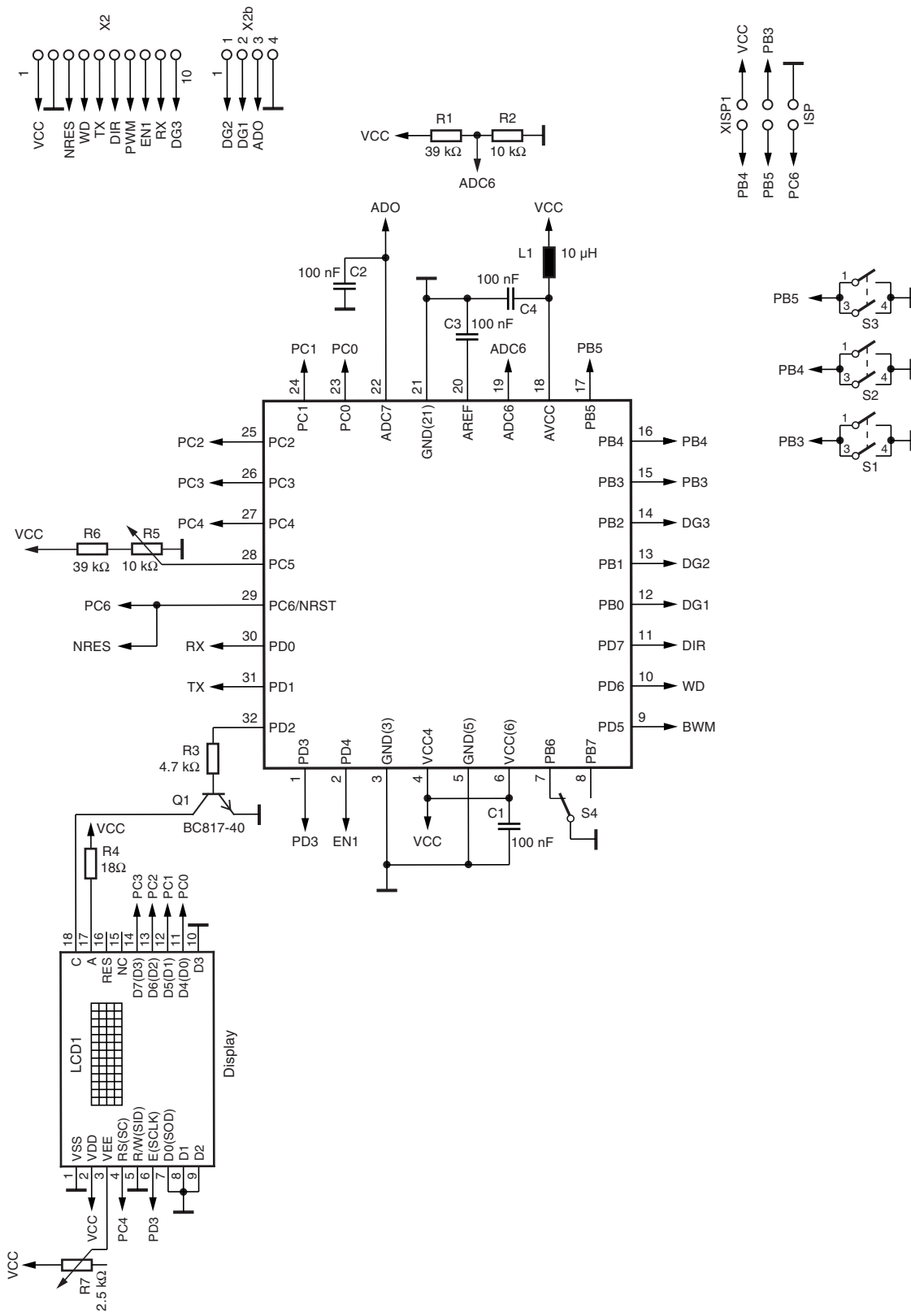

For further information please refer to the datasheet for the Atmel ATA6823.



Atmel Corporation

2325 Orchard Parkway
San Jose, CA 95131
USA

Tel: (+1)(408) 441-0311

Fax: (+1)(408) 487-2600

Atmel Asia Limited

Unit 01-5 & 16, 19/F
BEA Tower, Millennium City 5
418 Kwun Tong Road
Kwun Tong, Kowloon
HONG KONG

Tel: (+852) 2245-6100

Fax: (+852) 2722-1369

Atmel Munich GmbH

Business Campus
Parking 4
D-85748 Garching b. Munich
GERMANY

Tel: (+49) 89-31970-0

Fax: (+49) 89-3194621

Atmel Japan

9F, Tonetsu Shinkawa Bldg.
1-24-8 Shinkawa
Chuo-ku, Tokyo 104-0033
JAPAN

Tel: (+81) (3) 3523-3551

Fax: (+81) (3) 3523-7581

© 2011 Atmel Corporation. All rights reserved. / Rev.: 4961B-AUTO-02/11

Atmel®, Atmel logo and combinations thereof, AVR® and others are registered trademarks or trademarks of Atmel Corporation or its subsidiaries. Other terms and product names may be trademarks of others.

Disclaimer: The information in this document is provided in connection with Atmel products. No license, express or implied, by estoppel or otherwise, to any intellectual property right is granted by this document or in connection with the sale of Atmel products. EXCEPT AS SET FORTH IN THE ATMEL TERMS AND CONDITIONS OF SALES LOCATED ON THE ATMEL WEBSITE, ATMEL ASSUMES NO LIABILITY WHATSOEVER AND DISCLAIMS ANY EXPRESS, IMPLIED OR STATUTORY WARRANTY RELATING TO ITS PRODUCTS INCLUDING, BUT NOT LIMITED TO, THE IMPLIED WARRANTY OF MERCHANTABILITY, FITNESS FOR A PARTICULAR PURPOSE, OR NON-INFRINGEMENT. IN NO EVENT SHALL ATMEL BE LIABLE FOR ANY DIRECT, INDIRECT, CONSEQUENTIAL, PUNITIVE, SPECIAL OR INCIDENTAL DAMAGES (INCLUDING, WITHOUT LIMITATION, DAMAGES FOR LOSS AND PROFITS, BUSINESS INTERRUPTION, OR LOSS OF INFORMATION) ARISING OUT OF THE USE OR INABILITY TO USE THIS DOCUMENT, EVEN IF ATMEL HAS BEEN ADVISED OF THE POSSIBILITY OF SUCH DAMAGES. Atmel makes no representations or warranties with respect to the accuracy or completeness of the contents of this document and reserves the right to make changes to specifications and products descriptions at any time without notice. Atmel does not make any commitment to update the information contained herein. Unless specifically provided otherwise, Atmel products are not suitable for, and shall not be used in, automotive applications. Atmel products are not intended, authorized, or warranted for use as components in applications intended to support or sustain life.

Компания «Океан Электроники» предлагает заключение долгосрочных отношений при поставках импортных электронных компонентов на взаимовыгодных условиях!

Наши преимущества:

- Поставка оригинальных импортных электронных компонентов напрямую с производств Америки, Европы и Азии, а так же с крупнейших складов мира;
- Широкая линейка поставок активных и пассивных импортных электронных компонентов (более 30 млн. наименований);
- Поставка сложных, дефицитных, либо снятых с производства позиций;
- Оперативные сроки поставки под заказ (от 5 рабочих дней);
- Экспресс доставка в любую точку России;
- Помощь Конструкторского Отдела и консультации квалифицированных инженеров;
- Техническая поддержка проекта, помощь в подборе аналогов, поставка прототипов;
- Поставка электронных компонентов под контролем ВП;
- Система менеджмента качества сертифицирована по Международному стандарту ISO 9001;
- При необходимости вся продукция военного и аэрокосмического назначения проходит испытания и сертификацию в лаборатории (по согласованию с заказчиком);
- Поставка специализированных компонентов военного и аэрокосмического уровня качества (Xilinx, Altera, Analog Devices, Intersil, Interpoint, Microsemi, Actel, Aeroflex, Peregrine, VPT, Syfer, Eurofarad, Texas Instruments, MS Kennedy, Miteq, Cobham, E2V, MA-COM, Hittite, Mini-Circuits, General Dynamics и др.);

Компания «Океан Электроники» является официальным дистрибьютором и эксклюзивным представителем в России одного из крупнейших производителей разъемов военного и аэрокосмического назначения «JONHON», а так же официальным дистрибьютором и эксклюзивным представителем в России производителя высокотехнологичных и надежных решений для передачи СВЧ сигналов «FORSTAR».



JONHON

«JONHON» (основан в 1970 г.)

Разъемы специального, военного и аэрокосмического назначения:

(Применяются в военной, авиационной, аэрокосмической, морской, железнодорожной, горно- и нефтедобывающей отраслях промышленности)

«FORSTAR» (основан в 1998 г.)

ВЧ соединители, коаксиальные кабели,
кабельные сборки и микроволновые компоненты:

(Применяются в телекоммуникациях гражданского и специального назначения, в средствах связи, РЛС, а так же военной, авиационной и аэрокосмической отраслях промышленности).



Телефон: 8 (812) 309-75-97 (многоканальный)

Факс: 8 (812) 320-03-32

Электронная почта: ocean@oceanchips.ru

Web: <http://oceanchips.ru/>

Адрес: 198099, г. Санкт-Петербург, ул. Калинина, д. 2, корп. 4, лит. А