



PRELIMINARY

CYW54907

WICED™ IEEE 802.11 a/b/g/n/ac SoC with an Embedded Applications Processor

The Cypress CYW54907 embedded wireless system-on-a-chip (SoC) is uniquely suited for Internet-of-Things applications. It supports all rates specified in the IEEE 802.11a/b/g/n/ac specifications. The device includes an ARM Cortex-based applications processor, a single stream IEEE 802.11ac MAC/baseband/radio, dual-band 5GHz and 2.4GHz transmit power amplifiers (PA), and receive low-noise amplifiers (LNA). It also supports optional antenna diversity for improved RF performance in difficult environments.

The CYW54907 is an optimized SoC targeting embedded Internet-of-Things applications in the industrial and medical sensor, home appliance, and embedded audio markets. Using advanced design techniques and process technology to reduce active and idle power, the device is designed for embedded applications that require minimal power consumption and a compact size.

The device includes a PMU for simplifying system power topology and allows for direct operation from a battery while maximizing battery life.

Cypress part numbering scheme

Cypress is converting the acquired IoT part numbers from Broadcom to the Cypress part numbering scheme. Due to this conversion, there is no change in form, fit, or function as a result of offering the device with Cypress part number marking. The table provides Cypress ordering part number that matches an existing IoT part number.

Table 1. Mapping Table for Part Number between Broadcom and Cypress

Broadcom Part Number	Cypress Part Number
BCM54907	CYW54907
BCM54907KWBG	CYW54907KWBG

Features

Applications Processor Features

- ARM Cortex-R4 32-bit RISC processor.
- 2 MB of on-chip SRAM for code and data.
- An on-chip cryptography core
- 640 KB of ROM containing WICED SDK components such as RTOS and TCP/IP stack.
- 17 GPIOs supported.
- Q-SPI serial flash interface to support upto 40MBps of peak transfer.
- Support for UART, SPI (3), CSC-only (2), and I²S (2) interfaces. (Cypress Serial Control (CSC) is an I²C-compatible interface.)
- Dedicated fractional PLL for audio clock (MCLK) generation.
- USB 2.0 host and device modes.
- SDIO 3.0 host and device modes

Key IEEE 801.11x Features

- IEEE 802.11ac compliant with 256-QAM
- Single-stream spatial multiplexing upto 433.3Mbps.
- Supports 20/40/80 MHz channels with optional SGI.
- Full IEEE 802.11 a/b/g/n legacy compatibility with enhanced performance.
- TX and RX low-density parity check (LDPC) support for improved range and power efficiency.
- On-chip power and low-noise amplifiers.
- An internal fractional nPLL allows support for a wide range of reference clock frequencies.
- Integrated ARM Cortex-R4 processor with tightly coupled memory for complete WLAN sub system functionality, minimizing the need to wake up the applications processor for standard WLAN functions (to further minimize power consumption while maintaining the ability to upgrade to future features in the field).
- Software architecture supported by standard WICED SDK allows easy migration from existing discrete MCU designs and to future devices.

- Security support:
 - WPA and WPA2 (Personal) support for powerful encryption and authentication.
 - AES and TKIP in hardware for faster data encryption and IEEE 802.11i compatibility.
 - Reference WLAN subsystem provides Cisco Compatible Extensions (CCX, CCX 2.0, CCX 3.0, CCX 4.0, and CCX 5.0).
 - Wi-Fi Protected Setup and Wi-Fi Easy-Setup

- World wide regulatory support: Global products supported with worldwide design approval.

General Features

- Supports battery voltage range from 3.0V to 4.8V with an internal switching regulator.
- Programmable dynamic power management.
- 6 Kb OTP memory for storing board parameters.
- 316-bump WLCSP (4.583 mm × 5.533mm, 0.2mm pitch)

Figure 1. Functional Block Diagram

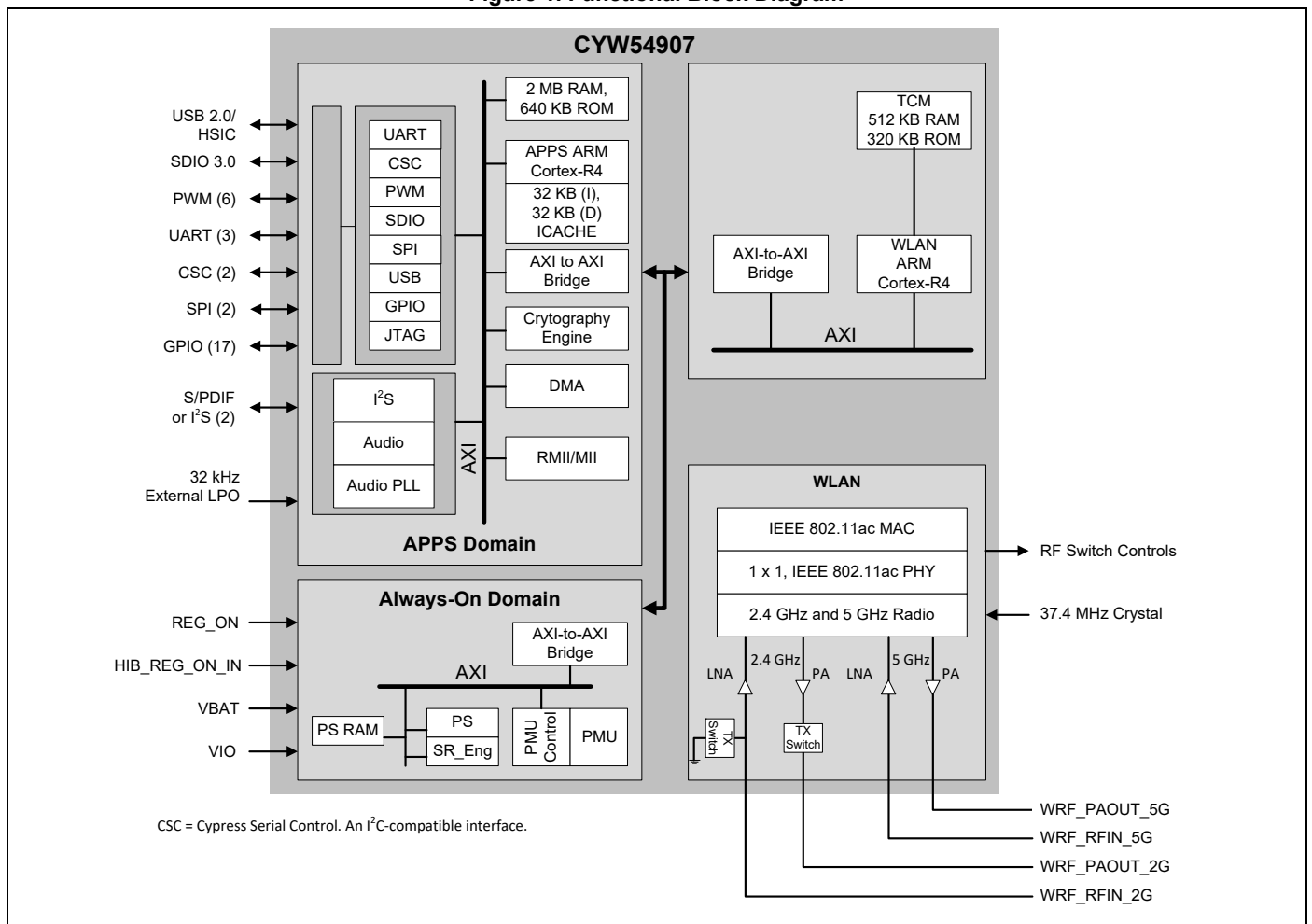

Contents

1. Overview	5	7. Wireless LAN Subsystem	26
1.1 Introduction	5	7.1 WLAN CPU and Memory Subsystem	26
1.1.1 Features	5	7.2 IEEE 802.11ac MAC	26
1.2 Standards Compliance	6	7.2.1 PSM	27
2. Power Supplies and Power Management	7	7.2.2 WEP	27
2.1 Power Supply Topology	7	7.2.3 TXE	28
2.2 CYW54907 Power Management Unit Features ..	7	7.2.4 RXE	28
2.3 Power Management	10	7.2.5 IFS	28
2.4 PMU Sequencing	10	7.2.6 TSF	28
2.5 Power-Off Shutdown	11	7.2.7 NAV	28
2.6 Power-Up/Power-Down/Reset Circuits	11	7.2.8 MAC-PHY Interface	29
3. Frequency References	12	7.3 IEEE 802.11™ a/b/g/n/ac PHY	29
3.1 Crystal Interface and Clock Generation	12	8. WLAN Radio Subsystem	31
3.2 External Frequency Reference	13	8.1 Receiver Path	31
3.3 External 32.768 kHz Low-Power Oscillator	14	8.2 Transmit Path	31
4. Applications Subsystem	15	8.3 Calibration	31
4.1 Overview	15	9. Pinout and Signal Descriptions	33
4.2 Applications CPU and Memory Subsystem	15	9.1 Bump List	34
4.3 Memory-to-Memory DMA Core	15	9.2 Signal Descriptions	38
4.4 Cryptography Core	15	10. GPIO Signals and Strapping Options	43
5. Applications Subsystem External Interfaces 16		10.1 Overview	43
5.1 Ethernet MAC Controller (MII/RMII)	16	10.2 Weak Pull-Down and Pull-Up Resistances	43
5.2 GPIO	16	10.3 Strapping Options	43
5.3 Cypress Serial Control	16	10.4 Alternate GPIO Signal Functions	44
5.4 I ² S	16	11. Pin Multiplexing	45
5.5 JTAG and ARM Serial Wire Debug	18	12. I/O States	48
5.6 PWM	18	13. Electrical Characteristics	50
5.7 SDIO 3.0	18	13.1 Absolute Maximum Ratings	50
5.7.1 SDIO 3.0—Device Mode	18	13.2 Environmental Ratings	50
5.7.2 SDIO 3.0—Host Mode	20	13.3 Electrostatic Discharge Specifications	51
5.8 S/PDIF	20	13.4 Recommended Operating Conditions and DC	51
5.9 SPI Flash	20	Characteristics 51	
5.10 UART	21	13.5 Power Supply Segments	53
5.11 USB 2.0	21	13.6 Ethernet MAC Controller (MII/RMII) DC	53
5.11.1 Overview	21	Characteristics	53
5.11.2 USB 2.0 Features	23	13.7 GPIO, UART, and JTAG Interfaces DC	53
5.12 SPI	23	Characteristics	53
6. Global Functions	24	14. WLAN RF Specifications	54
6.1 External Coexistence Interface	24	14.1 Introduction	54
6.2 One-Time Programmable Memory	24	14.2 2.4 GHz Band General RF Specifications	54
6.3 Hibernation Block	24	14.3 WLAN 2.4 GHz Receiver Performance	55
6.4 System Boot Sequence	25	Specifications	55
		14.4 WLAN 2.4 GHz Transmitter Performance	57
		Specifications 57	

14.5 WLAN 5 GHz Receiver Performance Specifications	58	17.5 SPI Flash Timing	82
14.6 WLAN 5 GHz Transmitter Performance Specifications	61	17.5.1 Read-Register Timing	82
14.7 General Spurious Emissions Specifications	62	17.5.2 Write-Register Timing	83
14.7.1 Transmitter Spurious Emissions Specifications	62	17.5.3 Memory Fast-Read Timing	84
14.7.2 Receiver Spurious Emissions Specifications	64	17.5.4 Memory-Write Timing	85
15. Internal Regulator Electrical Specifications. 65		17.5.5 SPI Flash Parameters	86
15.1 Core Buck Switching Regulator	65	17.6 USB PHY Electrical Characteristics and Timing	86
15.2 3.3V LDO (LDO3P3)	66	17.6.1 USB 2.0 and USB 1.1 Electrical and Timing Parameters	86
15.3 CLDO	67	17.6.2 USB 2.0 Timing Diagrams	88
15.4 LNLDO	68	18. Power-Up Sequence and Timing..... 90	
15.5 BBPLL LDO	69	18.1 Sequencing of Reset and Regulator Control Signals	90
16. System Power Consumption 70		18.1.1 Description of Control Signals	90
16.1 WLAN Current Consumption	70	18.1.2 Control Signal Timing Diagrams	90
16.1.1 2.4 GHz Mode	70	19. Thermal Information 91	
16.1.2 5 GHz Mode	71	19.1 Package Thermal Characteristics	91
17. Interface Timing and AC Characteristics..... 72		19.2 Junction Temperature Estimation and PSI_{JT} Versus $THETA_{JC}$	91
17.1 Ethernet MAC (MII/RMII) Interface Timing	72	19.3 Environmental Characteristics	91
17.1.1 MII Receive Packet Timing	72	20. Mechanical Information..... 92	
17.1.2 MII Transmit Packet Timing	72	21. Ordering Information 93	
17.1.3 RMII Receive Packet Timing	73	22. Additional Information 93	
17.1.4 RMII Transmit Packet Timing	74	22.1 Acronyms and Abbreviations	93
17.2 I ² S Master and Slave Mode TX Timing	75	22.2 References	93
17.3 SDIO Interface Timing	77	22.3 IoT Resources	93
17.3.1 SDIO Default-Speed Mode Timing	77	22.4 Errata	93
17.3.2 SDIO High-Speed Mode Timing	78	Document History Page..... 94	
17.3.3 SDIO Bus Timing Specifications in SDR Modes	79	Sales, Solutions, and Legal Information 95	
17.4 S/PDIF Interface Timing	80		

1. Overview

1.1 Introduction

The Cypress CYW54907 is a single-chip device that provides the highest level of integration for an embedded system-on-a-chip with integrated IEEE 802.11 a/b/g/n/ac MAC/baseband/radio and a separate ARM Cortex-R4 applications processor. It provides a small form-factor solution with minimal external components to drive down cost for mass volumes and allows for an embedded system with flexibility in size, form, and function. Comprehensive power management circuitry and software ensure that the system can meet the needs of highly embedded systems that require minimal power consumption and reliable operation.

Figure 1 shows the interconnect of all the major physical blocks in the CYW54907 and their associated external interfaces, which are described in greater detail in Section 5. “Applications Subsystem External Interfaces”.

Figure 1. Block Diagram and I/O

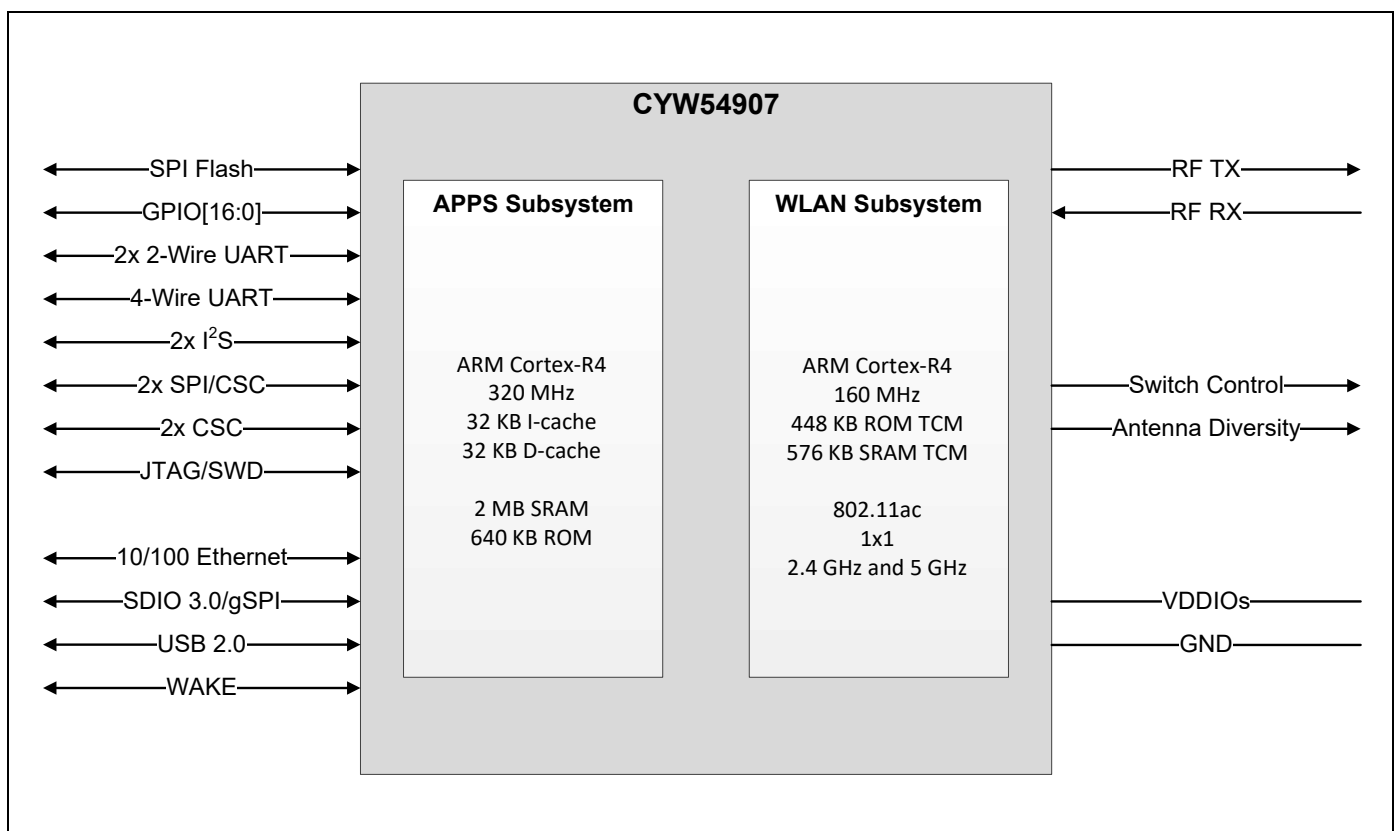

1.1.1 Features

The CYW54907 supports the following features:

- ARM Cortex-R4 clocked at 160 MHz (in 1× mode) or up to 320 MHz (in 2× mode).
- 2 MB of SRAM and 640 KB ROM available for the applications processor.
- One high-speed 4-wire UART interface with operation up to 4 Mbps.
- Two low-speed 2-wire UART interfaces multiplexed on general purpose I/O (GPIO) pins.
- Two dedicated CSC¹ interfaces.
- Two SPI master/slave interfaces with operation up to 24 MHz.

1. Cypress Serial Control (CSC) is an I²C-compatible interface.

Note: Either or both of the SPI interfaces can be used as CSC master interfaces. This is in addition to the two dedicated CSC interfaces.

- One SPI master interface for serial flash.
- Six dedicated PWM outputs.
- Two I²S interfaces.
- 17 GPIOs.
- IEEE 802.11 a/b/g/n/ac 1×1 2.4 GHz and 5 GHz radio.
- Single- and dual-antenna support.

1.2 Standards Compliance

The CYW54907 supports the following standards:

- IEEE 802.11ac
- IEEE 802.11n
- IEEE 802.11b
- IEEE 802.11g
- IEEE 802.11a
- IEEE 802.11d
- IEEE 802.11h
- IEEE 802.11i
- Security:
 - WEP
 - WPA Personal
 - WPA2 Personal
 - WMM
 - WMM-PS (U-APSD)
 - WMM-SA
 - AES (hardware accelerator)
 - TKIP (hardware accelerator)
 - CKIP (software support)
- Proprietary Protocols:
 - CCXv2
 - CCXv3
 - CCXv4
 - CCXv5
 - WFAEC

The CYW54907 supports the following additional standards:

- IEEE 802.11r—Fast Roaming (between APs)
- IEEE 802.11w—Secure Management Frames
- IEEE 802.11 Extensions:
 - IEEE 802.11e QoS enhancements (already supported as per the WMM specification)
 - IEEE 802.11i MAC enhancements
 - IEEE 802.11k radio resource measurement

2. Power Supplies and Power Management

2.1 Power Supply Topology

One core buck regulator, multiple LDO regulators, and a power management unit (PMU) are integrated into the CYW54907. All regulators are programmable via the PMU. These blocks simplify power supply design for application and WLAN functions in embedded designs.

A single VBAT (3.0V to 4.8V DC maximum) and VIO supply (1.8V to 3.3V) can be used, with all additional voltages being provided by the regulators in the CYW54907.

The REG_ON control signal is used to power up the regulators and take the appropriate sections out of reset. The CBUCK, CLDO, LNLDO, and other regulators power up when any of the reset signals are deasserted. All regulators are powered down only when REG_ON is deasserted. The regulators may be turned off/on based on the dynamic demands of the digital baseband.

The CYW54907 provides a low power-consumption mode whereby the CBUCK, CLDO, and LNLDO regulators are shut down. When in this state, the low-power linear regulator (LPLDO1) supplied by the system VIO supply provides the CYW54907 with all required voltages.

2.2 CYW54907 Power Management Unit Features

The CYW54907 supports the following Power Management Unit (PMU) features:

- VBAT to 1.35V_{out} (550 mA maximum) core buck (CBUCK) switching regulator
- VBAT to 3.3V_{out} (450 mA maximum) LDO3P3
- 1.35V to 1.2V_{out} (150 mA maximum) LNLDO
- 1.35V to 1.2V_{out} (350 mA maximum) CLDO with bypass mode for deep-sleep
- 1.35V to 1.2V_{out} (55 mA maximum) LDO for BBPLL
- Additional internal LDOs (not externally accessible)
- PMU internal timer auto-calibration by the crystal clock for precise wake-up timing from the low power-consumption mode.

[Figure 2](#) and [Figure 3](#) show the regulators and a typical power topology.

Figure 2. Typical Power Topology (Page 1 of 2)

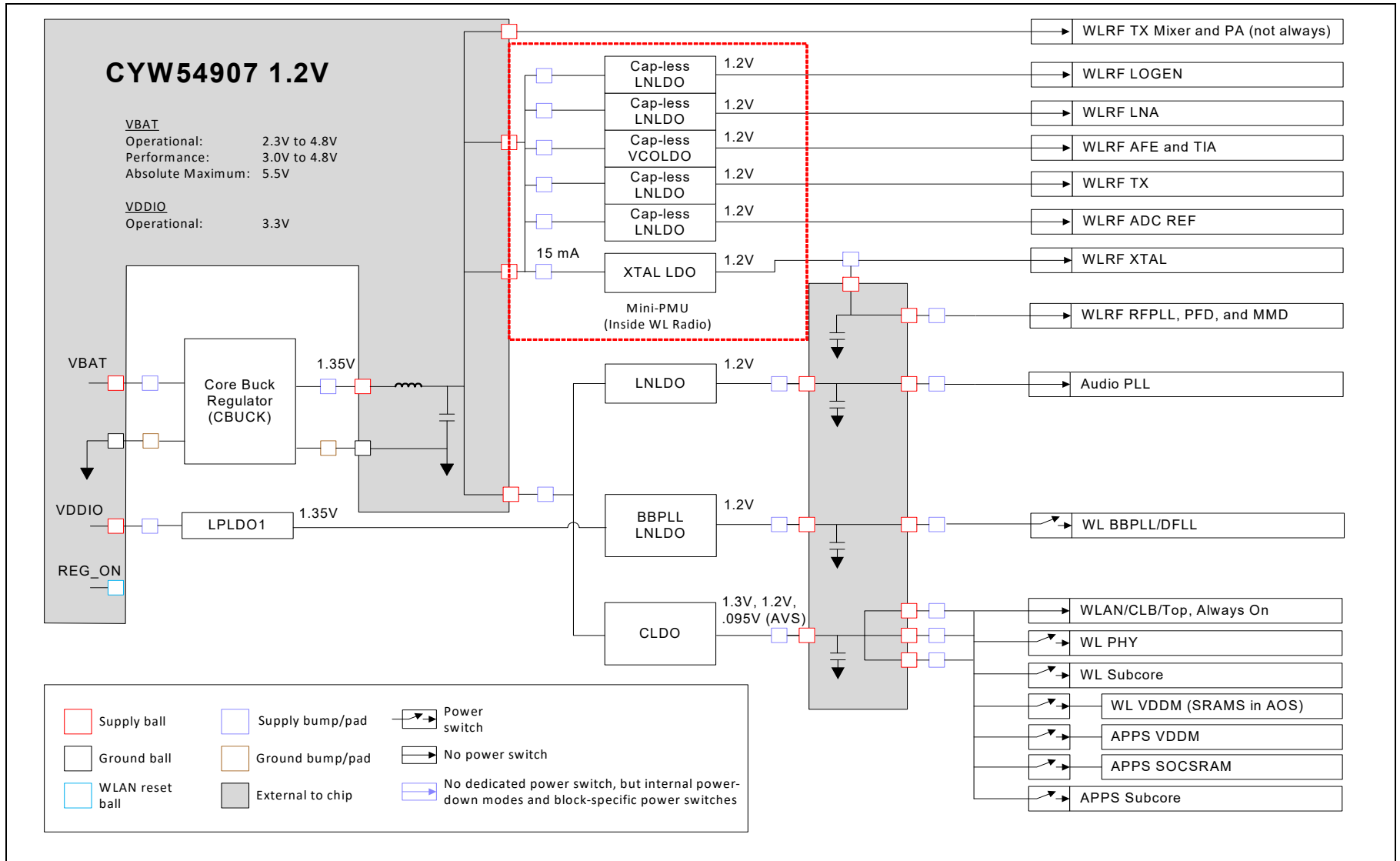
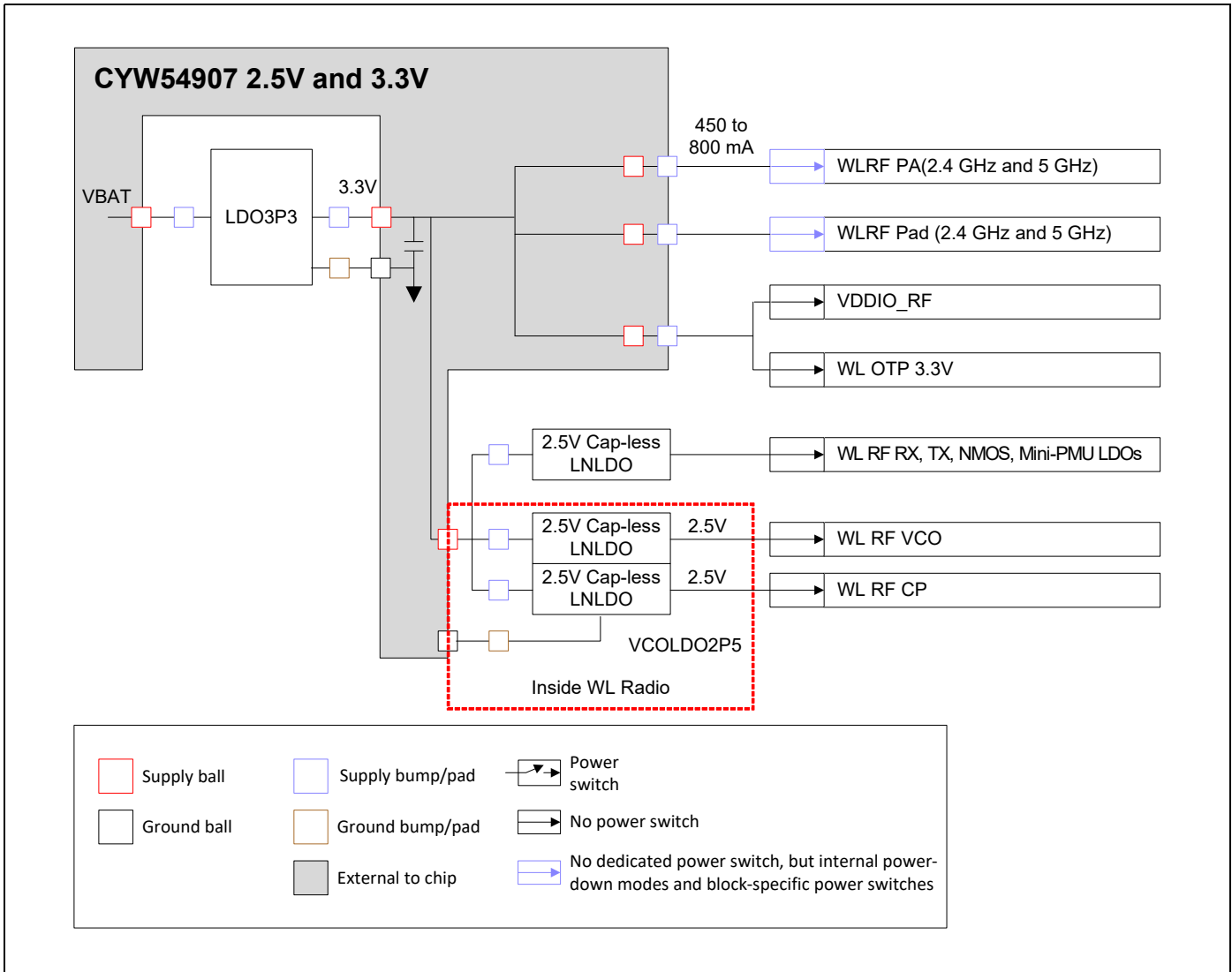

Figure 3. Typical Power Topology (Page 2 of 2)



2.3 Power Management

The CYW54907 has been designed with the stringent power consumption requirements of mobile devices in mind. All areas of the chip design are optimized to minimize power consumption. Silicon processes and cell libraries were chosen to reduce leakage current and supply voltages. Additionally, the CYW54907 includes an advanced Power Management Unit (PMU) sequencer. The PMU sequencer provides significant power savings by putting the CYW54907 into various power management states appropriate to the environment and activities that are being performed. The power management unit enables and disables internal regulators, switches, and other blocks based on a computation of the required resources and a table that describes the relationship between resources and the time needed to enable and disable them. Power-up sequences are fully programmable. Configurable, free-running counters (running at a 32.768 kHz LPO clock) in the PMU sequencer are used to turn on and turn off individual regulators and power switches. Clock speeds are dynamically changed (or gated altogether) as a function of the mode. Slower clock speeds are used whenever possible.

Table 1 provides descriptions for the CYW54907 power modes.

Table 1. CYW54907 Power Modes

Mode	Description
Active	All WLAN blocks in the CYW54907 are powered up and fully functional with active carrier sensing and frame transmission and receiving. All required regulators are enabled and put in the most efficient mode based on the load current. Clock speeds are dynamically adjusted by the PMU sequencer.
Doze	The radio, analog domains, and most of the linear regulators are powered down. The rest of the CYW54907 remains powered up in an idle state. All main clocks (PLL, crystal oscillator, or TCXO) are shut down to minimize active power consumption. The 32.768 kHz LPO clock is available only for the PMU sequencer. This condition is necessary to allow the PMU sequencer to wake up the chip and transition to Active mode. In Doze mode, the primary power consumed is due to leakage current.
Deep-sleep	Most of the chip, including both analog and digital domains and most of the regulators, is powered off. Logic states in the digital core are saved and preserved in a retention memory in the Always-On domain before the digital core is powered off. Upon a wake-up event triggered by the PMU timers, an external interrupt, or a host resume through the USB bus, logic states in the digital core are restored to their pre-deep-sleep settings to avoid lengthy HW reinitialization.
Power-down	The CYW54907 is effectively powered off by shutting down all internal regulators. The chip is brought out of this mode by external logic re-enabling the internal regulators.

2.4 PMU Sequencing

The PMU sequencer minimizes system power consumption. It enables and disables various system resources based on a computation of required resources and a table that describes the relationship between resources and the time required to enable and disable them.

Resource requests can come from several sources: clock requests from cores, the minimum resources defined in the *ResourceMin* register, and the resources requested by any active resource-request timers. The PMU sequencer maps clock requests into a set of resources required to produce the requested clocks.

Each resource is in one of the following four states:

- enabled
- disabled
- transition_on
- transition_off

The timer contains 0 when the resource is enabled or disabled and a nonzero value when in a transition state. The timer is loaded with the time_on or time_off value of the resource after the PMU determines that the resource must be enabled or disabled and decrements on each 32.768 kHz PMU clock. When it reaches 0, the state changes from transition_off to disabled or transition_on to enabled. If the time_on value is 0, the resource can transition immediately from disabled to enabled. Similarly, a time_off value of 0

indicates that the resource can transition immediately from enabled to disabled. The terms *enable sequence* and *disable sequence* refer to either the immediate transition or the timer load-decrement sequence.

During each clock cycle, the PMU sequencer performs the following actions:

- Computes the required resource set based on requests and the resource dependency table.
- Decrements all timers whose values are nonzero. If a timer reaches 0, the PMU clears the ResourcePending bit of the resource and inverts the ResourceState bit.
- Compares the request with the current resource status and determines which resources must be enabled or disabled.
- Initiates a disable sequence for each resource that is enabled, is no longer being requested, and has no powered-up dependents.
- Initiates an enable sequence for each resource that is disabled, is being requested, and has all of its dependencies enabled.

2.5 Power-Off Shutdown

The CYW54907 provides a low-power shutdown feature that allows the device to be turned off while the host, and any other system devices remain operational. When the CYW54907 is not needed in the system, VDDIO_RF and VDDC are shut down while VDDIO remains powered. This allows the CYW54907 to be effectively off while keeping the I/O pins powered so that they do not draw extra current from devices connected to the I/O.

During a low-power shutdown state, provided VDDIO remains applied to the CYW54907, all outputs are tristated and most inputs signals are disabled. Input voltages must remain within the limits defined for normal operation. This is done to prevent current paths or create loading on any digital signals in the system, and enables the CYW54907 to be fully integrated in an embedded device while taking full advantage of the lowest power-saving modes.

When the CYW54907 is powered on from this state, it is the same as a normal power-up and does not retain any information about its state from before it was powered down.

2.6 Power-Up/Power-Down/Reset Circuits

The CYW54907 has two signals (see [Table 2](#)) that enable or disable circuits and the internal regulator blocks, allowing the host to control power consumption. For timing diagrams of these signals and the required power-up sequences, see [Section 18. “Power-Up Sequence and Timing”](#).

Table 2. Power-Up/Power-Down/Reset Control Signals

Signal	Description
REG_ON	This signal is used by the PMU to power up the CYW54907. It controls the internal CYW54907 regulators. When this pin is high, the regulators are enabled and the device is out of reset. When this pin is low, the device is in reset and the regulators are disabled. This pin has an internal 200 kΩ pull-down resistor that is enabled by default. It can be disabled through programming.
HIB_REG_ON_IN	This signal is used by the hibernation block to decide whether or not to power down the internal CYW54907 regulators. If HIB_REG_ON_IN is low, the regulators will be disabled. For a signal at HIB_REG_ON_IN to function as intended, HIB_REG_ON_OUT must be connected to REG_ON.

3. Frequency References

An external crystal is used for generating all radio frequencies and normal-operation clocking. As an alternative, an external frequency reference can be used. In addition, a low-power oscillator (LPO) is provided for lower power mode timing.

3.1 Crystal Interface and Clock Generation

The CYW54907 can use an external crystal to provide a frequency reference. The recommended crystal oscillator configuration, including all external components, is shown in Figure 4. Consult the reference schematics for the latest configuration.

Figure 4. Recommended Oscillator Configuration

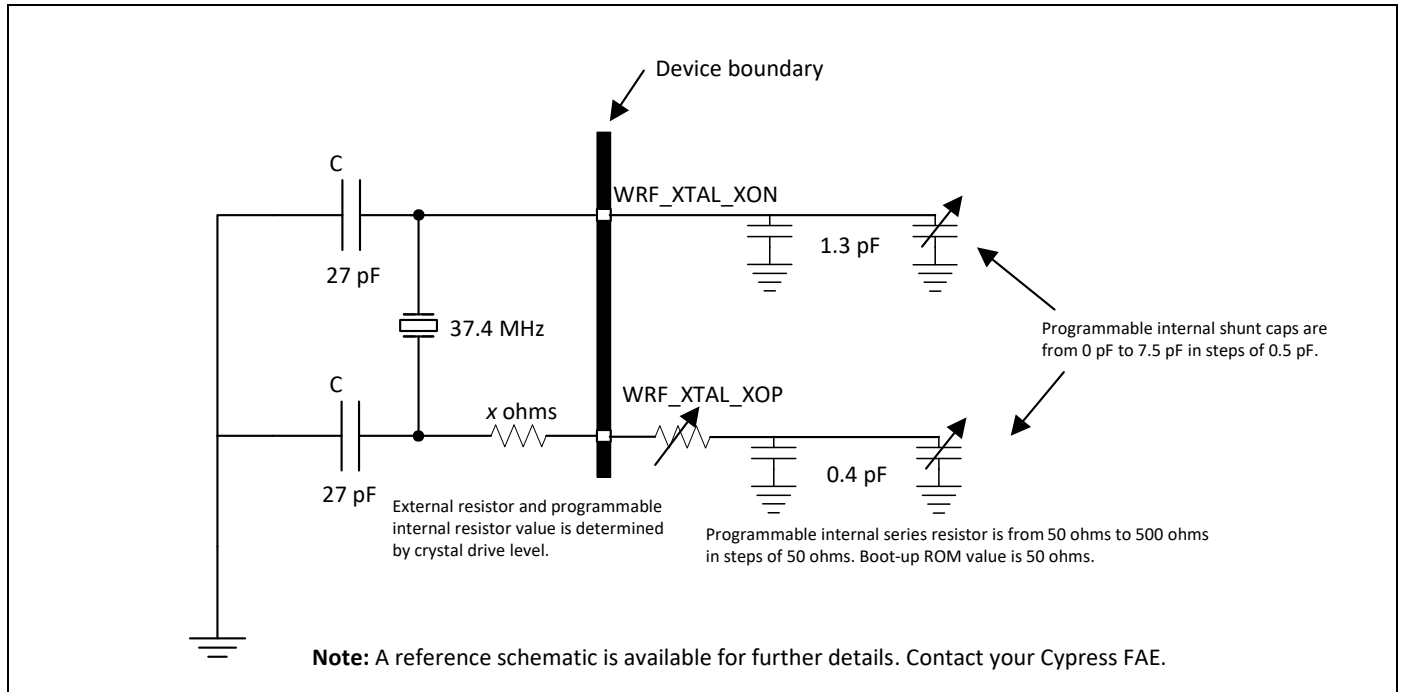

A fractional-N synthesizer in the CYW54907 generates the radio frequencies, clocks, and data/packet timing, enabling it to operate using a wide selection of frequency references.

The recommended default frequency reference is a 37.4 MHz crystal. The signal characteristics for the crystal interface are listed in Table 3.

Note: Although the fractional-N synthesizer can support alternative reference frequencies, frequencies other than the default require support to be added in the driver, plus additional extensive system testing. Contact Cypress for further details.

3.2 External Frequency Reference

As an alternative to a crystal, an external precision frequency reference can be used, provided that it meets the phase noise requirements listed in [Table 3](#).

If used, the external clock should be connected to the WRF_XTAL_XON pin through an external 1000 pF coupling capacitor, as shown in [Figure 5](#). The internal clock buffer connected to this pin will be turned off when the CYW54907 goes into sleep mode. When the clock buffer turns on and off, there will be a small impedance variation. Power must be supplied to the WRF_XTAL_VDD1P35 pin.

Figure 5. Recommended Circuit to Use With an External Reference Clock

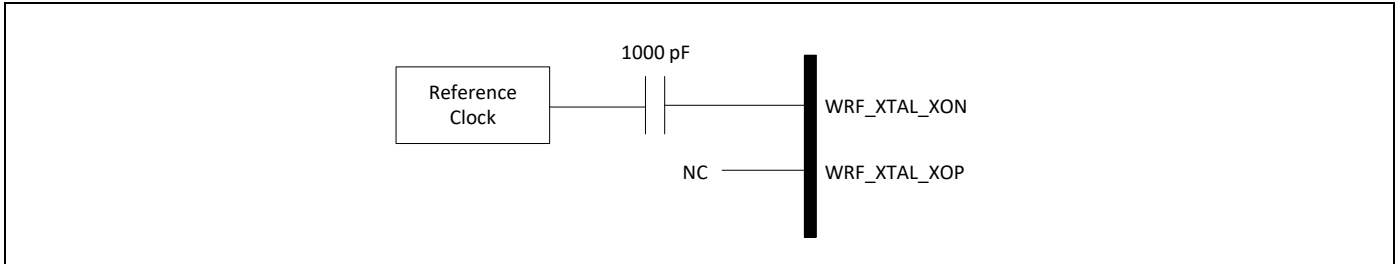

Table 3. Crystal Oscillator and External Clock—Requirements and Performance

Parameter	Conditions/Notes	Crystal ^a			External Frequency Reference ^{b c}			Units
		Min.	Typ.	Max.	Min.	Typ.	Max.	
Frequency	2.4 GHz and 5 GHz bands: IEEE 802.11a/b/g/n/ac operation	–	37.4	–	–	37.4	–	MHz
Frequency tolerance over the lifetime of the equipment, including temperature ^c	Without trimming	–20	–	20	–20	–	20	ppm
Crystal load capacitance	–	–	16	–	–	–	–	pF
ESR	–	–	–	60	–	–	–	Ω
Drive level	External crystal must be able to tolerate this drive level.	200	–	–	–	–	–	μW
Input impedance (WRF_XTAL_XON)	Resistive	–	–	–	30k	100k	–	Ω
	Capacitive	–	–	7.5	–	–	7.5	pF
WRF_XTAL_XON Input low level	DC-coupled digital signal	–	–	–	0	–	0.2	V
WRF_XTAL_XON Input high level	DC-coupled digital signal	–	–	–	1.0	–	1.26	V
WRF_XTAL_XON input voltage (see Figure 5)	IEEE 802.11a/b/g operation only	–	–	–	400	–	1200	mV _{p-p}
WRF_XTAL_XON input voltage (see Figure 5)	IEEE 802.11n/ac AC-coupled analog input	–	–	–	1	–	–	V _{p-p}
Duty cycle	37.4 MHz clock	–	–	–	40	50	60	%
Phase noise ^d (IEEE 802.11b/g)	37.4 MHz clock at 10 kHz offset	–	–	–	–	–	–129	dBc/Hz
	37.4 MHz clock at 100 kHz offset	–	–	–	–	–	–136	dBc/Hz
Phase noise ^d (IEEE 802.11a)	37.4 MHz clock at 10 kHz offset	–	–	–	–	–	–137	dBc/Hz
	37.4 MHz clock at 100 kHz offset	–	–	–	–	–	–144	dBc/Hz
Phase noise ^d (IEEE 802.11n, 2.4 GHz)	37.4 MHz clock at 10 kHz offset	–	–	–	–	–	–134	dBc/Hz
	37.4 MHz clock at 100 kHz offset	–	–	–	–	–	–141	dBc/Hz
Phase noise ^d (IEEE 802.11n/ac, 5 GHz)	37.4 MHz clock at 10 kHz offset	–	–	–	–	–	–142	dBc/Hz
	37.4 MHz clock at 100 kHz offset	–	–	–	–	–	–149	dBc/Hz

- a. (Crystal) Use WRF_XTAL_XON and WRF_XTAL_XOP.
- b. See “[External Frequency Reference](#)” for alternative connection methods.
- c. It is the responsibility of the equipment designer to select oscillator components that comply with these specifications.
- d. Assumes that external clock has a flat phase noise response above 100 kHz.

3.3 External 32.768 kHz Low-Power Oscillator

The CYW54907 uses a secondary low frequency clock for low-power-mode timing. Either the internal low-precision LPO or an external 32.768 kHz precision oscillator is required. The internal LPO frequency range is approximately 33 kHz \pm 30% over process, voltage, and temperature, which is adequate for some applications. However, one tradeoff caused by this wide LPO tolerance is a small current consumption increase during power save mode that is incurred by the need to wake-up earlier to avoid missing beacons.

Whenever possible, the preferred approach is to use a precision external 32.768 kHz clock that meets the requirements listed in [Table 4](#).

Table 4. External 32.768 kHz Sleep Clock Specifications

Parameter	LPO Clock	Units
Nominal input frequency	32.768	kHz
Frequency accuracy	\pm 200	ppm
Duty cycle	30–70	%
Input signal amplitude	200–3300	mV, p-p
Signal type	Square-wave or sine-wave	–
Input impedance ^a	>100k <5	Ω pF
Clock jitter (during initial start-up)	<10,000	ppm

- a. When power is applied or switched off.

4. Applications Subsystem

4.1 Overview

The Applications subsystem contains the general use CPU, memory, the standalone DMA core, the cryptography core, and the majority of the external interfaces.

4.2 Applications CPU and Memory Subsystem

This subsystem has an integrated 32-bit ARM Cortex-R4 processor with an internal 32 KB D-cache and an internal 32 KB I-cache. The ARM Cortex-R4 is a low-power processor that features a low gate count, low interrupt latency, and low-cost debugging capabilities. It is intended for deeply embedded applications that require fast interrupt response features. The ARM Cortex-R4 implements the ARM v7-R architecture and supports the Thumb-2 instruction set.

At 0.19 $\mu\text{W}/\text{MHz}$, the Cortex-R4 is the most power efficient general-purpose microprocessor available, outperforming 8- and 16-bit devices on a MIPS/ μW basis. It also supports integrated sleep modes.

Using multiple technologies to reduce cost, the ARM Cortex-R4 enables improved memory utilization, reduced pin overhead, and reduced silicon area. It also has extensive debugging features, including real-time tracing of program execution.

On-chip memory for the CPU includes 2 MB SRAM, 640 KB ROM, and an 8 KB RAM powered independently of the application subsystem.

4.3 Memory-to-Memory DMA Core

The CYW54907 memory-to-memory DMA (M2MDMA) engine contains eight DMA channel pairs, each containing one transmit/pull engine and one receive/push engine.

The DMA engine provides general purpose data movement between memories that can be on the device, attached directly to the device, or accessed through a host interface. The transmit/pull engine reads data from the source memory and immediately passes it to the paired receive/push engine, which proceeds to write it to the destination memory. Multiple masters can program the individual channels, and multiple interrupts are provided so that interrupts for different channels can be routed separately to different masters.

4.4 Cryptography Core

The cryptography block provides a hardware accelerator for enciphering and deciphering data that has undergone processing using standards-based encryption algorithms. The cryptography block includes the following primary features:

- Encryption and hash engines that support single pass AUTH-ENC or ENC-AUTH processing.
- A scalable AES module that supports CBC, ECB, CTR, CFB, OFB, and XTS encryption with 128-, 192-, and 256-bit key sizes.
- A scalable DES module that supports DES and 3DES in ECB and CBC modes.
- An RC4 stream cipher module that supports state initialization, state update, and key-stream generation.
- MD5, SHA1, SHA224, and SHA256 engines that support pure hash or HMAC operations.
- A built-in 512-byte key cache for locally protected key storage.

OTP memory is used to store authentication keys.

5. Applications Subsystem External Interfaces

5.1 Ethernet MAC Controller (MII/RMII)

The CYW54907 integrates a high performance Ethernet MAC controller. The controller interfaces to an external PHY either over a Media Independent Interface (MII) or a Reduced Media Independent Interface (RMII). The controller can transmit and receive data at 10 Mbps and 100 Mbps.

5.2 GPIO

There are 17 general-purpose I/O (GPIO) pins available on the CYW54907. The GPIOs can be used to connect to various external devices.

Upon power-up and reset, these pins are tristated. Subsequently, they can be programmed to be either input or output pins via the GPIO control register. In addition, the GPIO pins can be assigned to various other functions.

Apart from other functions, GPIOs are used to set bootstrap options and use the JTAG interface for debugging during software development.

5.3 Cypress Serial Control

The CYW54907 has two Cypress Serial Control (CSC) master interfaces for external communication with codecs, DACs, NVRAM, etc. The I/O pads can be configured as pull-ups or pull-downs can be installed on the reference design to support a multimaster on an open drain bus.

The I2C0 CSC master interface can support repeated start, however it does not support clock stretching. The I2C1 CSC master interface does not support repeated start or clock stretching. The CSC master can support a maximum clock frequency of 400kHz.

If clock stretching is required a bit banging driver is recommended. Cypress's WICED SDK provides an example of such a bit banging I2C driver. Note that only I2C0 mentioned in [Table 10](#) is multiplexed with GPIOs and supports bit banging. I2C1 is not multiplexed with GPIOs and therefore cannot support bit banging.

5.4 I²S

The CYW54907 has two I²S interfaces for audio signal data. The two interfaces are identical. Each interface supports both Master and Slave modes.

The following signals apply to the first I²S interface:

- I²S bit clock: I²S_SCLK0 (sometimes referred to as I²S_BITCLK)
- I²S word select: I²S_LRCK0 (sometimes referred to as I²S_WS)
- I²S serial data out: I²S_SDATAO0
- I²S serial data in: I²S_SDATAI0
- I²S master clock: I²S_MCLK0

The following signals apply to the second I²S interface:

- I²S bit clock: I²S_SCLK1 (sometimes referred to as I²S_BITCLK)
- I²S word select: I²S_LRCK1 (sometimes referred to as I²S_WS)
- I²S serial data out: I²S_SDATAO1
- I²S serial data in: I²S_SDATAI1
- I²S master clock: I²S_MCLK1

I²S_SDATAO0 and I²S_SDATAO1 are outputs.

I²S_MCLK, I²S_SCLK and I²S_LRCLK can be configured as either inputs or outputs depending on whether the master clock source is on- or off-chip and whether the I²S is operating in Slave or Master mode.

Channel word lengths of 16 bits, 20 bits, 24 bits, and 32 bits are supported, and the data is justified so that the MSB of the left-channel data is aligned with the MSB of the I²S bus, per the I²S specification. The MSB of each data word is transmitted one bit-clock cycle after the I²S_LRCK transition, synchronous with the falling edge of the bit clock. Left-channel data is transmitted when I²S_LRCK is

low, and right-channel data is transmitted when I²S_LRCK is high. An embedded 128 × 32-bit single-port SRAM for data processing enhances the performance of the interface.

An audio PLL generates an internal master clock (for I²S_MCLK0 and I²S_MCLK1) that provides support for various sampling rates.

Note: In I²S slave mode if LRCLK changes on the rising edge of the bit clock, the MSB data bit is set half of a bit cycle after LRCLK.

Table 5 shows the MCLK rates (in MHz) associated with each of the various sample rates. In the table, FS refers to the sample rate in kHz and typical MCLK rates are shaded.

Table 5. Variable Sample Rate and MCLK Rate Support^a

Sample Rate (kHz)	MCLK Rate (MHz) ^b							
	128 × FS	192 × FS	256 × FS	384 × FS	512 × FS	640 × FS	768 × FS	1152 × FS
8	1.024	1.536	2.048	3.072	4.096	5.12	6.144	9.216
11.025	1.4112	2.1168	2.8224	4.2336	5.6448	7.056	8.4672	12.7008
12	1.536	2.304	3.072	4.608	6.144	7.68	9.216	13.824
16	2.048	3.072	4.096	6.144	8.192	10.24	12.288	18.432
22.05	2.8224	4.2336	5.6448	8.4672	11.2896	14.112	16.9344	25.4016
24	3.072	4.608	6.144	9.216	12.288	15.36	18.432	27.648
32	4.096	6.144	8.192	12.288	16.384	20.48	24.576	36.864
44.1	5.6448	8.4672	11.2896	16.9344	22.5792	28.224	33.8688	–
48	6.144	9.216	12.288	18.432	24.576	30.72	36.864	–
64	8.192	12.288	16.384	24.576	32.768	–	–	–
88.2	11.2896	16.9344	22.5792	33.8688	–	–	–	–
96	12.288	18.432	24.576	36.864	–	–	–	–
192	24.576	36.864	–	–	–	–	–	–

a. All data in the table assumes a crystal frequency of 37.4 MHz.

b. MCLK frequency errors are less than 1 ppb.

For an MCLK specification, see Table 45.

5.5 JTAG and ARM Serial Wire Debug

The CYW54907 supports the IEEE 1149.1 JTAG boundary scan standard for performing device package and PCB assembly testing during manufacturing. In addition, the JTAG interface allows Cypress to assist customers by using proprietary debug and characterization test tools during board bring-up. Therefore, it is highly recommended to provide access to the JTAG pins by means of test points or a header on all PCB designs.

The CYW54907 also supports ARM Serial Wire Debug (SWD) for connecting a JTAG debugger directly to both ARM Cortex-R4s. For SWD, the combination of a clock and a bidirectional signal (on a single pin) provides normal JTAG debug and test functionality. The reduced pin-count SWD interface is a high-performance alternative to the JTAG interface.

Table 6 shows the JTAG_SEL and TAP_SEL states for test and debug function selection. Test and debug function selection is independent of the debugging interface (JTAG or SWD) being used.

Table 6. JTAG_SEL and TAP_SEL States for Test and Debug Function Selection

JTAG_SEL State	TAP_SEL State	Test and Debug Function
0	0	JTAG not used.
0	1	JTAG not used.
1	0	Access the LV tap directly for ATE and bring-up.
1	1	Access either of the ARM Cortex-R4's directly via either the 5-pin JTAG port or the 2-pin SWD configuration.

Note: JTAG_SEL is exposed on a dedicated physical pin. TAP_SEL uses the GPIO_8 physical pin.

5.6 PWM

The CYW54907 provides up to six independent pulse width modulation (PWM) channels. The following features apply to the PWM channels:

- Each channel is a square wave generator with a programmable duty cycle.
- Each channel generates its duty cycle by dividing down the input clock.
- Both the high and low duration of the duty cycle can be divided down independently by a 16-bit divider register.
- Each channel can work independently or update simultaneously.
- Pairs of PWM outputs can be inverted for devices that need a differential output.
- Continuous or single pulses can be generated.
- The input clock can either be a high-speed clock from a PLL channel or a lower speed clock at the crystal frequency.

5.7 SDIO 3.0

5.7.1 SDIO 3.0—Device Mode

Description

The CYW54907 WLAN section supports SDIO version 3.0, including the new UHS-I modes:

- DS: Default speed (DS) up to 25 MHz, including 1- and 4-bit modes (3.3V signaling).
- HS: High-speed up to 50 MHz (3.3V signaling).
- SDR12: SDR up to 25 MHz (1.8V signaling).
- SDR25: SDR up to 50 MHz (1.8V signaling).

Note: The CYW54907 is backward compatible with SDIO v2.0 host interfaces.

The following three functions are supported:

- Function 0 Standard SDIO function (max. BlockSize/ByteCount = 32B)
- Function 1 Backplane Function to access the internal SoC address space (max. BlockSize/ByteCount = 64B)
- Function 2 WLAN Function for efficient WLAN packet transfer through DMA (max. BlockSize/ByteCount = 512B)

SDIO Pins

Table 7. SDIO Pin Descriptions

SD 4-Bit Mode		SD 1-Bit Mode	
DATA0	Data line 0	DATA	Data line
DATA1	Data line 1 or Interrupt	IRQ	Interrupt
DATA2	Data line 2 or Read Wait	RW	Read Wait
DATA3	Data line 3	N/C	Not used
CLK	Clock	CLK	Clock
CMD	Command line	CMD	Command line

Figure 6. Signal Connections to an SDIO Host (SD 4-Bit Mode)

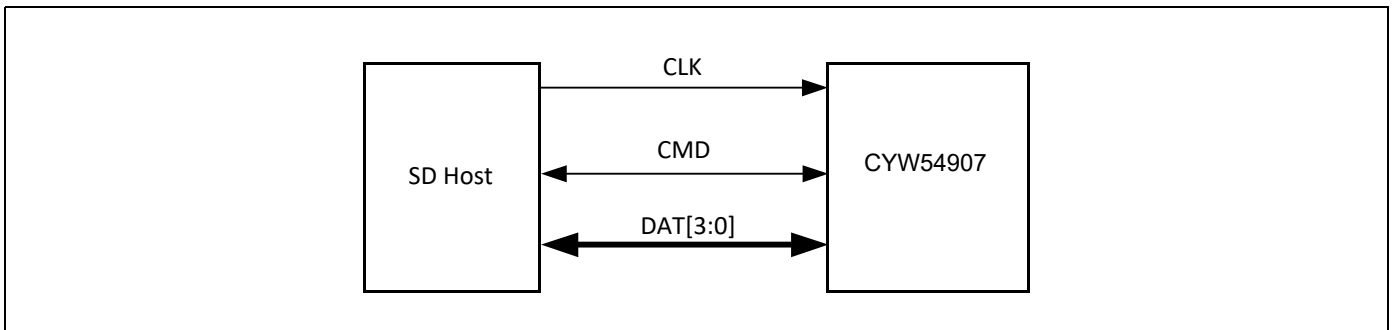
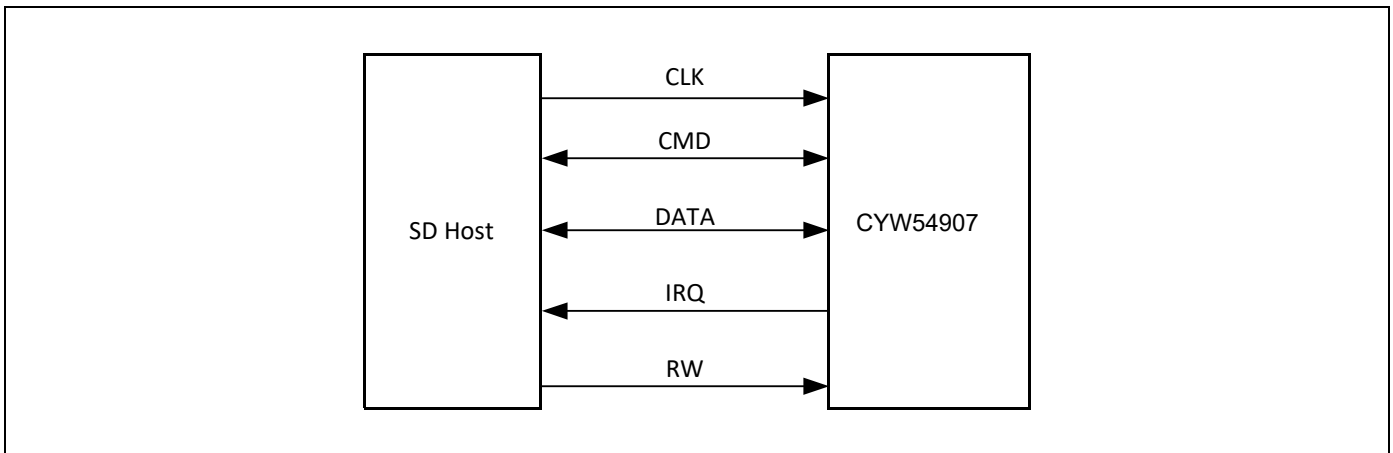

Figure 7. Signal Connections to an SDIO Host (SD 1-Bit Mode)



Note: Per Section 6 of the SDIO specification, pull-ups in the 10 kΩ to 100 kΩ range are required on the four data (DATA) lines and the command (CMD) line. This requirement must be met during all operating states either through the use of external pull-up resistors or through proper programming of the SDIO host's internal pull-ups

5.7.2 SDIO 3.0—Host Mode

The CYW54907 WLAN section supports SDIO version 3.0, including the new UHS-I modes:

- DS: Default speed (DS) up to 25 MHz, including 1- and 4-bit modes (3.3V signaling).
- HS: High-speed up to 50 MHz (3.3V signaling).
- SDR12: SDR up to 25 MHz (1.8V signaling).
- SDR25: SDR up to 50 MHz (1.8V signaling).
- SDR50: SDR up to 100 MHz (1.8V signaling).

Note: The CYW54907 is backward compatible with SDIO v2.0 devices.

In this mode, the device supports the following features:

- ADMA2.
- Out-of-band signaling for card detection, write protection, and I/O voltage levels (which are available on GPIOs).
- Dynamic, specification-compliant shifting from 3.3V to 1.8V I/Os.

5.8 S/PDIF

S/PDIF is a serial audio data transport format used to connect consumer audio devices such as CD players, DVD players, and surround-sound receivers. Although S/PDIF can be used to transport uncompressed audio formats, the primary use case for the CYW54907 S/PDIF interface is to transport multichannel compressed audio for surround-sound applications, especially Dolby Digital and DTS, to an auxiliary external audio processor.

The CYW54907 can support two S/PDIF interfaces via the I²S_SDATA00 and I²S_SDATA01 pins. Because each S/PDIF interface uses an I²S data line, only I²S or S/PDIF functionality can be enabled on each I²S interface.

Each S/PDIF interface has the following key requirements:

- S/PDIF transmissions that conform with IEC 60958-1 (receiver not required).
- Support for linear PCM audio data that conforms with IEC 60948-3.
- Support for nonlinear PCM audio data that conforms with IEC 60948-3.
- Support for priority payload formats that include IEC 61937-3 (AC-3) and IEC 61937-5 (DTS).
- Support for sample rates from 32 kHz to 192 kHz.
- Support for 16, 20, and 24-bit audio samples.
- Support for only one concurrent compressed audio stream.

5.9 SPI Flash

The SPI flash interface supports the following features:

- A SPI-compatible serial bus.
- An 80 MHz (maximum) clock frequency.
- Increased Throughput to 40 MBps in Quad-mode or upto 10 MBps in single Mode²
- Support for either ×1 or ×4 addresses with ×4 data.
- 3-bytes and 4-byte addressing modes.
- A configurable dummy-cycle count that is programmable from 1 to 15.
- Programmable instructions output to serial flash.
- An option to change the sampling edge from rising-edge to falling-edge for read-back data when in high-speed mode.

2. Note that the clock needs to be constrained to ~26.67MHz for reliable operation at high operating temperatures. The throughput of the SPI Flash block is therefore restricted to ~13 MBps for Quad mode and ~3 MBps for single mode.

5.10 UART

A high-speed 4-wire CTS/RTS UART interface can be enabled by software and has dedicated pins. Provided primarily for debugging during development, this UART enables the CYW54907 to operate as RS-232 data termination equipment (DTE) for exchanging and managing data with other serial devices. It is compatible with the industry standard 16550 UART and provides a FIFO size of 64 × 8 in each direction.

There are two low-speed UART interfaces on the CYW54907. Each functions as a standard 2-wire UART. They are also enabled as alternate functions on GPIOs and can be enabled independently of the 4-wire fast UART.

Note: The high-speed, 4-wire UART interface is identified as UART0 in this document and in reference schematics. The two low-speed, 2-wire UART interfaces are identified as UART1 and UART2 in this document and in the reference schematics.

5.11 USB 2.0

5.11.1 Overview

The USB 2.0 host controller (HC) and device controller (DC) interface to a backplane via Advanced extensible Interface (AXI) and Advanced Peripheral Bus (APB). They interface externally through a USB 2.0 and HSIC interfaces.

Figure 8 shows the topology of the USB 2.0 core.

Figure 8. Topology of the USB 2.0 Core

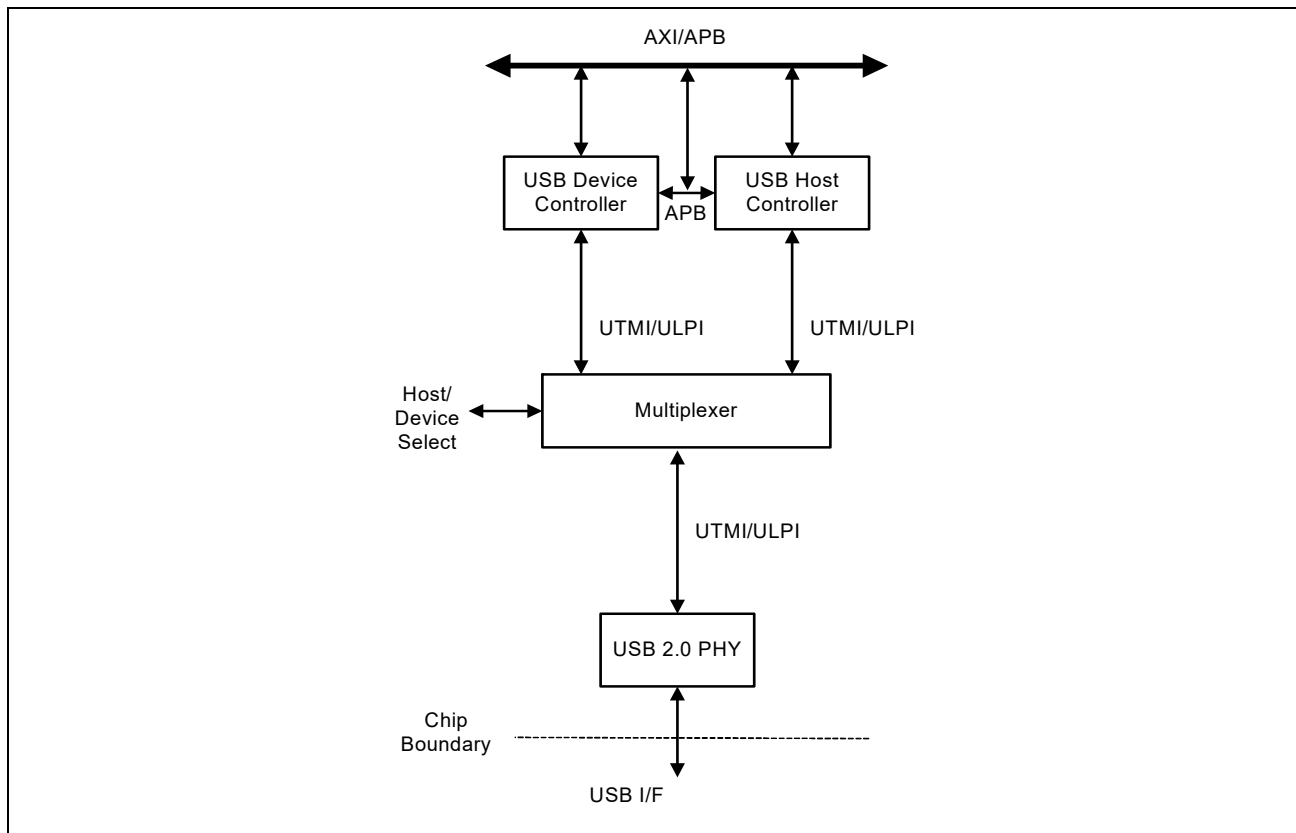

The CYW54907 contains both a USB 2.0 HC and DC. Therefore, it can operate in the host-only, device-only, and dual-role device (DRD) modes. In DRD mode, the CYW54907 can be configured as either the host or a device on the fly but must remain in the same mode until the next boot cycle. The restriction that the host or device mode remains fixed during a boot cycle is what differentiates DRD from On-the-Go (OTG).

The state of the USB2_DSEL pin sets the mode as either host or device for USB Type A and Type B connectors. For a USB Micro-AB connector, the USB2_DSEL pin sets the mode as either host or device while the overall mode is DRD.

Table 8 shows the supported application cases. The table also shows the USB mode and PHY type, the connector type, and the USB2_DSEL state associated with each case.

Table 8. USB Application Cases

Application Case Shorthand	Mode	PHY	USB2_DSEL	Connector Information
DRD + USB 2.0 PHY	DRD-Host	USB 2.0	0	Type: Micro-AB
	DRD-Device	USB 2.0	1	Connect USB2_DSEL to the ID pin of the Micro-AB receptacle.
Host + USB 2.0 PHY	Host	USB 2.0	0	Type A
Device + USB2.0 PHY	Device	USB 2.0	1	Type B

Note: In host mode, the USB core can process an overcurrent event and take the appropriate action. The overcurrent event is input into the CYW54907 via the alternative mode pin USB20H_CTL.

Figure 9 shows the CYW54907 configured to operate in DRD mode with a USB 2.0 PHY.

Figure 9. CYW54907 Configured as a DRD + USB 2.0 PHY

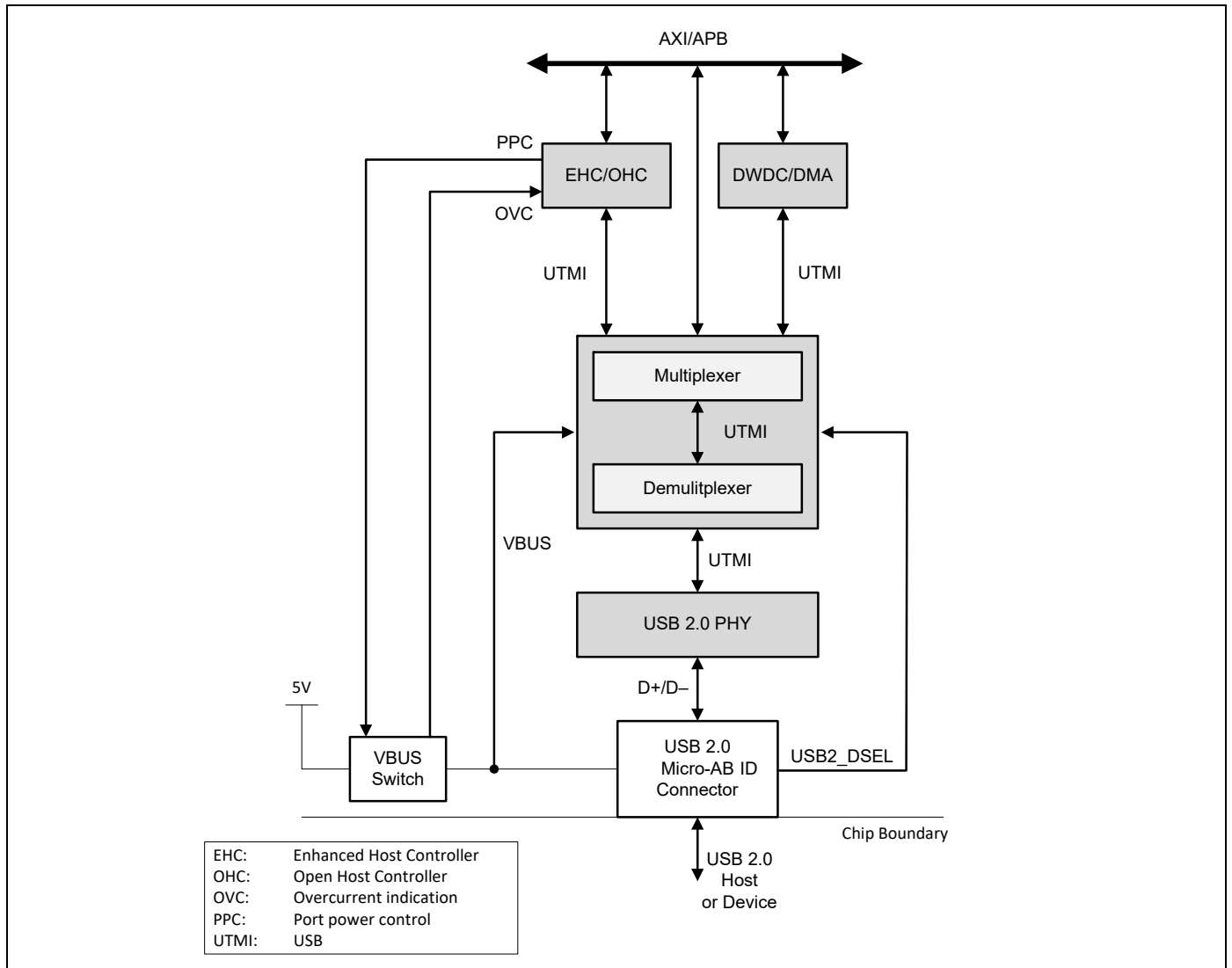

The following information pertains to [Figure 9](#):

- The Micro-AB receptacle connects the CYW54907 to an external host or device.
- The Micro-AB connector ID pin is connected to the CYW54907 USB2_DSEL pin.
- The CYW54907 GPIO_9 pin is high in order to select the USB 2.0 PHY.
- The PPC line indicates whether the USB 2.0 host controller supports port power control.
- The OVC line is used to indicate an overcurrent condition.
- Standard differential signal lines D+ (DP) and D- (DM) are used for the USB 2.0 interface

5.11.2 USB 2.0 Features

The following capabilities and features apply to the CYW54907 USB 2.0 PHY:

- Compliant with the UTMI+ level 2 specification.
- Functions as a host or device, or OTG PHY.
- Supports high speed (HS) at 480 Mbps, full speed (FS) at 12 Mbps, and low speed (LS) at 1.5 Mbps.
- Integrates pull-up and pull-down terminations with resistor support (per an engineering change notice to the USB 2.0 specification).
- Contains a calibrated 45Ω termination for HS TX/RX.
- Uses half-duplex differential data signaling with NRZI encoding.
- Recovers the data and clock from the data stream.
- Integrates a 960 MHz PLL with a single-ended reference clock.
- Supports host resume and remote wake-up.
- Supports L1 and L2 suspend, shallow sleep, and Link-Power Management (LPM).
- Supports legacy USB 1.1 devices through a serial interface.
- Supports dribble bits.
- Supports LS keep-alive packets (LS EOP).
- Support HS keep-alive packets (HS SYNC).
- Contains an onboard BERT for self-testing (PRBS and fixed patterns).
- Dissipates a maximum power of 150 mW for 1-port in loop-back mode.
- Contains an integrated 3.3V to 1.2V LDO.
- Uses 3.3V.

5.12 SPI

CYW54907 contains 2 SPI blocks. These blocks support a fixed SPI mode (CPOL = 0, CPHA = 0) and 8-bit data read/write.

- CPOL = 0: Clock idles at 0, and each cycle consists of a pulse of 1. The leading edge is a rising edge, and the trailing edge is a falling edge.
- CPHA = 0: The "out" side changes the data on the trailing edge of the preceding clock cycle, while the "in" side captures the data on (or shortly after) the leading edge of the clock cycle.

The SPI hardware blocks support a hold time of 25ns and a maximum clock frequency of 40MHz.

If a SPI slave does not support the above mode or requires a hold time greater than 25ns, a bit banging software SPI driver should be used. Cypress's WICED SDK provides an example of such a driver. Note that the maximum SPI frequency support by a software SPI driver is much lower than 40 MHz.

SPI0 mentioned in [Table 10](#) is multiplexed with GPIOs and can therefore support a bit banging based software SPI driver. SPI1 is not multiplexed with GPIOs and cannot support a bit banging based software SPI driver.

6. Global Functions

6.1 External Coexistence Interface

An external handshake interface is available to enable signaling between the device and an external colocated wireless device, such as Bluetooth, to manage wireless medium sharing for optimum performance.

Figure 10 shows the coexistence interface.

Figure 10. Cypress 2-Wire External Coexistence Interface

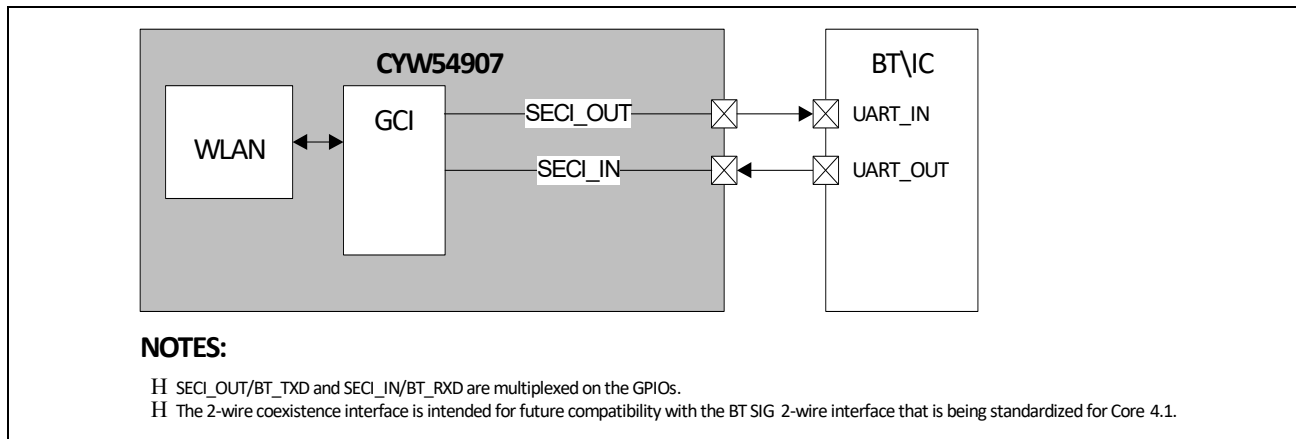

Note: SECI UART is the same as UART2, one of the low-speed UART interfaces mentioned in section 5.10 and in the reference schematics.

6.2 One-Time Programmable Memory

Various hardware configuration parameters can be stored in an internal 6144-bit (768 bytes) One-Time Programmable (OTP) memory that is read by system software after a device reset. In addition, customer-specific parameters, including the system vendor ID and MAC address can be stored, depending on the specific board design.

The initial state of all bits in an unprogrammed OTP memory device is 0. After any bit is programmed to a 1, it cannot be reprogrammed to 0. The entire OTP memory array can be programmed in a single write-cycle using a utility provided with the Cypress WLAN manufacturing test tools. Alternatively, multiple write cycles can be used to selectively program specific bytes, but only bits that are still in the 0 state can be altered during each programming cycle.

Prior to OTP memory programming, all values should be verified using the appropriate editable nvram.txt file. The nvram.txt file is provided with the reference board design package.

6.3 Hibernation Block

The Hibernation (HIB) block is a self-contained power domain that can be used to completely shut down the rest of the CYW54907. This optional block uses the HIB_REG_ON_OUT pin to drive the REG_ON pin. Therefore, for the HIB block to work as designed, the HIB_REG_ON_OUT pin must be connected to the REG_ON pin. To use the HIB block, software programs the HIB block with a wake count and then asserts a signal indicating that the chip should be put into hibernation. After assertion, the HIB block drives HIB_REG_ON_OUT low for the number of 32 kHz clock cycles programmed as the wake count. After the wake-count timer expires, HIB_REG_ON_OUT is driven high. Other than the logic state of the HIB block, no state is saved in the CYW54907 during hibernation.

6.4 System Boot Sequence

The following general sequence occurs after a CYW54907 is powered on:

1. Either REG_ON or HIB_REG_ON_IN is asserted.

Note: For HIB_REG_ON_IN to function as intended, HIB_REG_ON_OUT must be connected to REG_ON.

2. The core LDO (CLDO) and LDO3P3 outputs stabilize.
3. The OTP memory bits are used to initialize various functions, such as PMU trimming, package selection, memory size selection, etc.
4. The APP and WLAN cores are powered up.
5. The XTAL is powered up.
6. The APP and WLAN CPU bootup sequences start.

7. Wireless LAN Subsystem

7.1 WLAN CPU and Memory Subsystem

The CYW54907 WLAN section includes an integrated 32-bit ARM Cortex-R4 processor with internal RAM and ROM. The ARM Cortex-R4 is a low-power processor that features a low gate count, a small interrupt latency, and low-cost debug capabilities. It is intended for deeply embedded applications that require fast interrupt response features. Delivering more than a 30% performance gain over ARM7TDMI, the ARM Cortex-R4 implements the ARM v7-R architecture with support for the Thumb-2 instruction set.

At 0.19 $\mu\text{W}/\text{MHz}$, the Cortex-R4 is the most power efficient general-purpose microprocessor available, outperforming 8- and 16-bit devices on MIPS/ μW . It also supports integrated sleep modes.

On-chip memory for this CPU includes 576 KB of SRAM and 448 KB of ROM.

7.2 IEEE 802.11ac MAC

The CYW54907 WLAN media access controller (MAC) is designed to support high-throughput operation with low power consumption. It does so without compromising the Bluetooth coexistence policies, thereby enabling optimal performance over both networks. In addition, several power-saving modes have been implemented that allow the MAC to consume very little power while maintaining network-wide timing synchronization. The architecture diagram of the MAC is shown in [Figure 11](#).

The following sections provide an overview of the important MAC modules.

Figure 11. WLAN MAC Architecture

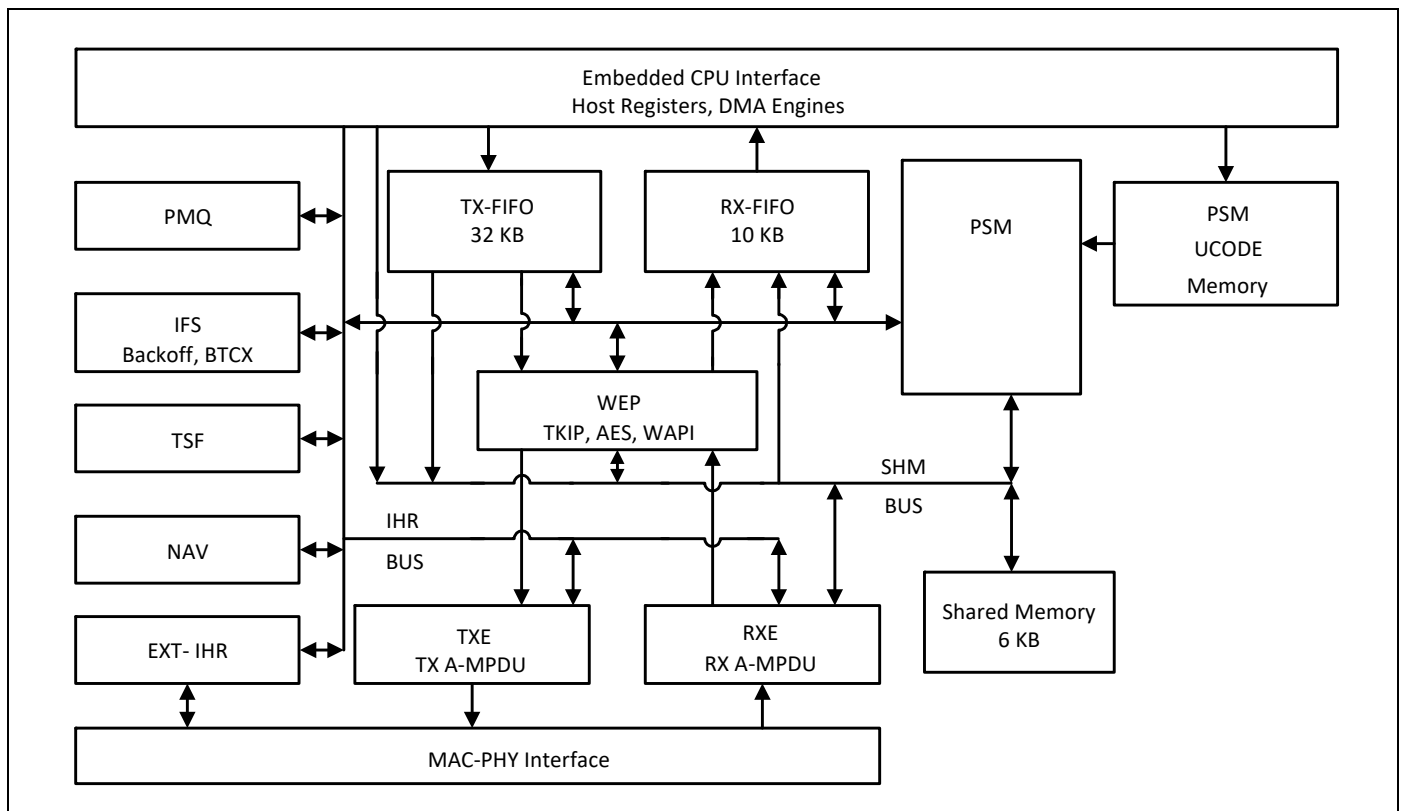

The CYW54907 WLAN MAC supports features specified in the IEEE 802.11 base standard and amended by IEEE 802.11n/ac. The key MAC features include:

- Enhanced MAC for supporting IEEE 802.11ac features.
- Transmission and reception of aggregated MPDUs (A-MPDU) for high throughput (HT).
- Support for power management schemes, including WMM power-save, power-save multi-poll (PSMP), and multiphase PSMP operation.
- Support for immediate ACK and Block-ACK policies.
- Interframe space timing support, including RIFS.
- Support for RTS/CTS and CTS-to-self frame sequences for protecting frame exchanges.
- Back-off counters in hardware for supporting multiple priorities as specified in the WMM specification.
- Timing synchronization function (TSF), network allocation vector (NAV) maintenance, and target beacon transmission time (TBTT) generation in hardware.
- Hardware offload for AES-CCMP, legacy WPA TKIP, legacy WEP ciphers, WAPI, and support for key management.
- Hardware offload engine for IEEE 802.11 to IEEE 802.3 header conversion for receive packets.
- Support for coexistence with Bluetooth and other external radios.
- Programmable independent basic service set (IBSS) or infrastructure basic service set functionality.
- Statistics counters for MIB support.

7.2.1 PSM

The programmable state machine (PSM) is a microcoded engine that provides most of the low-level control to the hardware in order to implement the IEEE 802.11 specification. It is a microcontroller that is highly optimized for flow-control operations, which are predominant in implementations of communication protocols. The instruction set and fundamental operations are simple and general, allowing algorithms to be optimized very late in the design process. It also allows for changes to the algorithms to track evolving IEEE 802.11 specifications.

The PSM fetches instructions from microcode memory. It uses the shared memory to obtain operands for instructions, as a data store, and to exchange data between both the host and the MAC data pipeline (via the SHM bus). The PSM also uses a scratch-pad memory (similar to a register bank) to store frequently accessed and temporary variables.

The PSM exercises fine-grained control over the hardware engines by programming internal hardware registers (IHR). These IHRs are colocated with the hardware functions they control and are accessed by the PSM via the IHR bus.

The PSM fetches instructions from the microcode memory using an address determined by the program counter, instruction literal, or a program stack. For ALU operations, the operands are obtained from shared memory, scratch-pad memory, IHRs, or instruction literals, and the results are written into the shared memory, scratch-pad memory, or IHRs.

There are two basic branch instructions: conditional branches and ALU-based branches. To better support the many decision points in the IEEE 802.11 algorithms, branches can depend on either readily available signals from the hardware modules (branch condition signals are available to the PSM without polling the IHRs) or on the results of ALU operations.

7.2.2 WEP

The wired equivalent privacy (WEP) engine encapsulates all the hardware accelerators to perform encryption and decryption as well as MIC computation and verification. The accelerators implement the following cipher algorithms: legacy WEP, WPA TKIP, WPA2 AES-CCMP.

The PSM determines, based on the frame type and association information, the appropriate cipher algorithm to use. It supplies the keys to the hardware engines from an on-chip key table. The WEP interfaces with the transmit engine (TXE) to encrypt and compute the MIC on transmit frames and the receive engine (RXE) to decrypt and verify the MIC on receive frames.

7.2.3 TXE

The transmit engine (TXE) constitutes the transmit data path of the MAC. It coordinates the DMA engines to store the transmit frames in the TXFIFO. It interfaces with the WEP module to encrypt frames and transfers the frames across the MAC-PHY interface at the appropriate time determined by the channel-access mechanisms.

The data received from the DMA engines are stored in transmit FIFOs. The MAC has multiple logical queues to support traffic streams that have different QoS priority requirements. The PSM uses the channel access information from the IFS module to schedule a queue from which the next frame is transmitted. Once the frame is scheduled, the TXE hardware transmits the frame based on a precise timing trigger received from the IFS module.

The TXE module also contains the hardware that allows the rapid assembly of MPDUs into an A-MPDU for transmission. The hardware module aggregates the encrypted MPDUs by adding appropriate headers and pad delimiters as needed.

7.2.4 RXE

The receive engine (RXE) constitutes the receive data path of the MAC. It interfaces with the DMA engine to drain the received frames from the RXFIFO. It transfers bytes across the MAC-PHY interface and interfaces with the WEP module to decrypt frames. The decrypted data is stored in the RXFIFO.

The RXE module contains filters that are programmed by the PSM to accept or filter frames based on several criteria such as receiver address, BSSID, and certain frame types.

The RXE module also contains the hardware required to detect A-MPDUs, parse the headers of the containers, and disaggregate them into component MPDUS.

7.2.5 IFS

The IFS module contains the timers required to determine interframe-space timing including RIFS timing. It also contains multiple backoff engines required to support prioritized access to the medium as specified by WMM.

The interframe-spacing timers are triggered by the cessation of channel activity on the medium, as indicated by the PHY. These timers provide precise timing to the TXE to begin frame transmission. The TXE uses this information to send response frames or perform transmit frame-bursting (RIFS or SIFS separated, as within a TXOP).

The backoff engines (for each access category) monitor channel activity, in each slot duration, to determine whether to continue or pause the backoff counters. When the backoff counters reach 0, the TXE gets notified so that it may commence frame transmission. In the event of multiple backoff counters decrementing to 0 at the same time, the hardware resolves the conflict based on policies provided by the PSM.

The IFS module also incorporates hardware that allows the MAC to enter a low-power state when operating under the IEEE power save mode. In this mode, the MAC is in a suspended state with its clock turned off. A sleep timer, whose count value is initialized by the PSM, runs on a slow clock and determines the duration over which the MAC remains in this suspended state. When the timer expires, the MAC is restored to its functional state. The PSM updates the TSF timer based on the sleep duration, ensuring that the TSF is synchronized to the network.

The IFS module also contains the PTA hardware that assists the PSM in Bluetooth coexistence functions.

7.2.6 TSF

The timing synchronization function (TSF) module maintains the TSF timer of the MAC. It also maintains the target beacon transmission time (TBTT). The TSF timer hardware, under the control of the PSM, is capable of adopting timestamps received from beacon and probe response frames in order to maintain synchronization with the network.

The TSF module also generates trigger signals for events that are specified as offsets from the TSF timer, such as uplink and downlink transmission times used in PSMP.

7.2.7 NAV

The network allocation vector (NAV) timer module is responsible for maintaining the NAV information conveyed through the duration field of MAC frames. This ensures that the MAC complies with the protection mechanisms specified in the standard.

The hardware, under the control of the PSM, maintains the NAV timer and updates the timer appropriately based on received frames. This timing information is provided to the IFS module, which uses it as a virtual carrier-sense indication.

7.2.8 MAC-PHY Interface

The MAC-PHY interface consists of a data path interface to exchange RX/TX data from/to the PHY. In addition, there is an programming interface that can be controlled either by the host or the PSM to configure and control the PHY.

7.3 IEEE 802.11™ a/b/g/n/ac PHY

The CYW54907 WLAN digital PHY complies with IEEE 802.11a/b/g/n single-stream specifications to provide wireless LAN connectivity supporting data rates from 1 Mbps to 433.3 Mbps for low-power, high-performance, handheld applications.

The PHY has been designed to work in the presence of interference, radio nonlinearity, and various other impairments. It incorporates optimized implementations of filters, FFTs, and Viterbi-decoder algorithms. Efficient algorithms have been designed to achieve maximum throughput and reliability, including algorithms for carrier sensing and rejection, frequency/phase/timing acquisition and tracking, and channel estimation and tracking. The PHY receiver also contains a robust IEEE 802.11b demodulator. The PHY carrier-sensing algorithm provides high throughput for IEEE 802.11b/g hybrid networks with Bluetooth coexistence.

The key PHY features include:

- Programmable data rates from MCS0–7 in 20 MHz and 40 MHz channels.
- Support for Optional Short GI and Green Field modes in TX and RX.
- TX and RX LDPC for improved range and power efficiency.
- All scrambling, encoding, forward error correction, and modulation in the transmit direction and inverse operations in the receive direction.
- Support for IEEE 802.11h/k for worldwide operation.
- Advanced algorithms for low power consumption and enhanced sensitivity, range, and reliability.
- Algorithms to improve performance in the presence of externally received Bluetooth signals.
- An automatic gain control scheme for blocking and nonblocking cellular applications.
- Closed loop transmit power control.
- Digital RF chip calibration algorithms to handle CMOS RF chip process, voltage, and temperature (PVT) variations.
- On-the-fly channel frequency and transmit power selection.
- Per-packet RX antenna diversity.
- Available per-packet channel quality and signal-strength measurements.
- Compliance with FCC and other worldwide regulatory requirements.

Figure 12. WLAN PHY Block Diagram

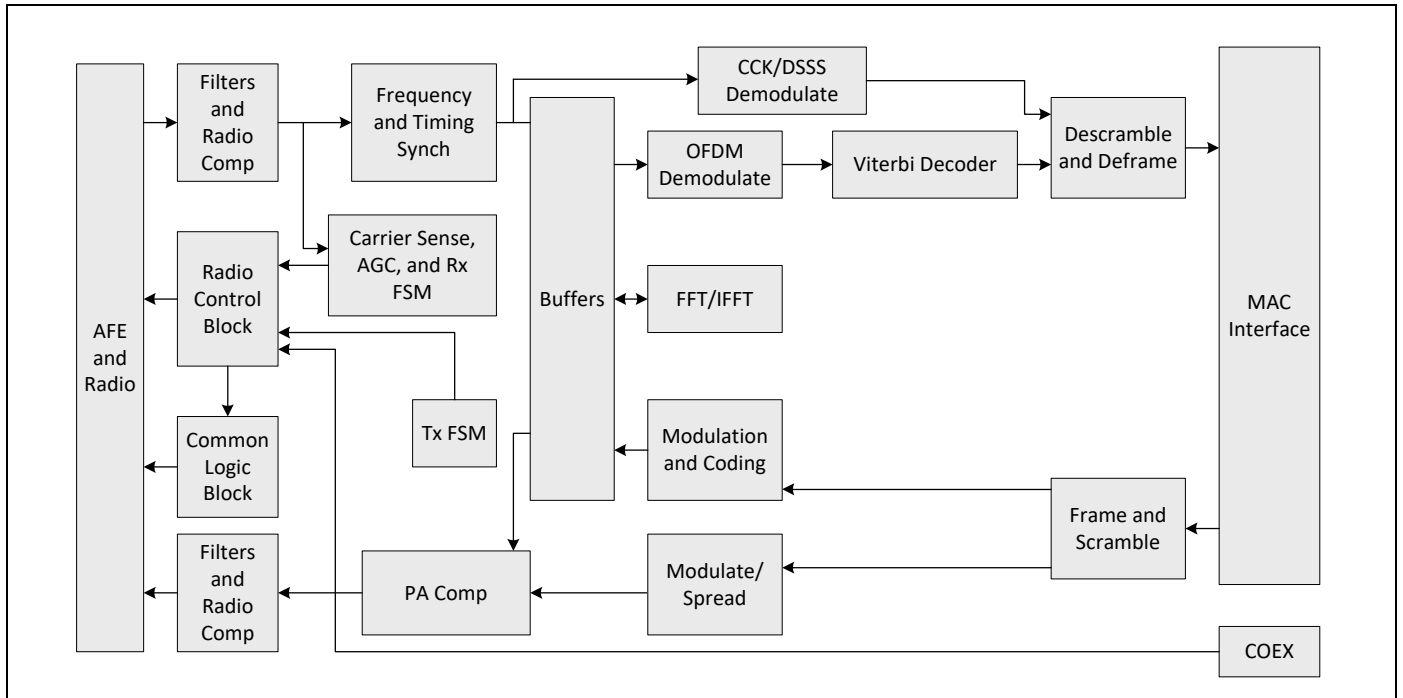

8. WLAN Radio Subsystem

The CYW54907 includes an integrated dual-band WLAN RF transceiver that has been optimized for use in 2.4 GHz and 5 GHz Wireless LAN systems. It has been designed to provide low-power, low-cost, and robust communications for applications operating in the globally available 2.4 GHz unlicensed ISM or 5 GHz U-NII bands. The transmit and receive sections include all on-chip filtering, mixing, and gain control functions.

Ten RF control signals are available to drive external RF switches. In addition, these control signals can be used to support optional external 5 GHz band power and low-noise amplifiers. See the reference board schematics for more information.

A block diagram of the radio subsystem is shown in [Figure 13](#). Note that integrated on-chip baluns (not shown) convert the fully differential transmit and receive paths to single-ended signal pins.

8.1 Receiver Path

The CYW54907 has a wide dynamic range, direct conversion receiver that employs high-order on-chip channel filtering to ensure reliable operation in the noisy 2.4 GHz ISM band or the entire 5 GHz U-NII band. The 2.4 GHz and 5 GHz paths each have a dedicated on-chip low-noise amplifier (LNA).

8.2 Transmit Path

Baseband data is modulated and upconverted to the 2.4 GHz ISM or 5 GHz U-NII bands, respectively. Linear on-chip power amplifiers deliver high output powers while meeting IEEE 802.11a/b/g/n/ac specifications without the need for external PAs. When using the internal PA, which is required in the 2.4 GHz band and optional in the 5 GHz band, closed-loop output power control is completely integrated.

8.3 Calibration

The CYW54907 features dynamic and automatic on-chip calibration to continually compensate for temperature and process variations across components. These calibration routines are performed periodically during the course of normal radio operation. Examples of some of the automatic calibration algorithms are baseband filter calibration for optimum transmit and receive performance and LOFT calibration for carrier leakage reduction. In addition, I/Q calibration and VCO calibration are performed on-chip. No per-board calibration is required during manufacturing testing. This helps to minimize the test time and cost in large-volume production environments.

Figure 13. Radio Functional Block Diagram

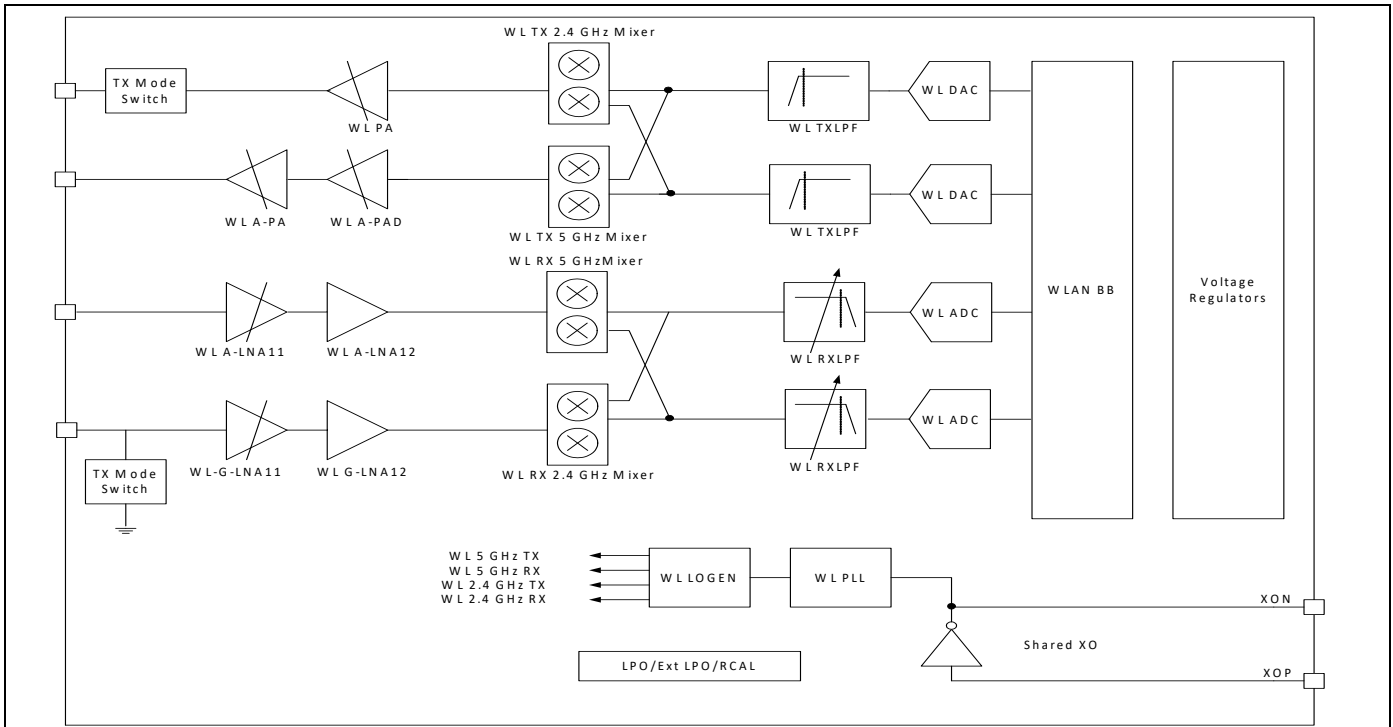

9. Pinout and Signal Descriptions

Figure 14 shows the bump map of the WLCSP package.

Figure 14. 316-Bump WLCSP Map

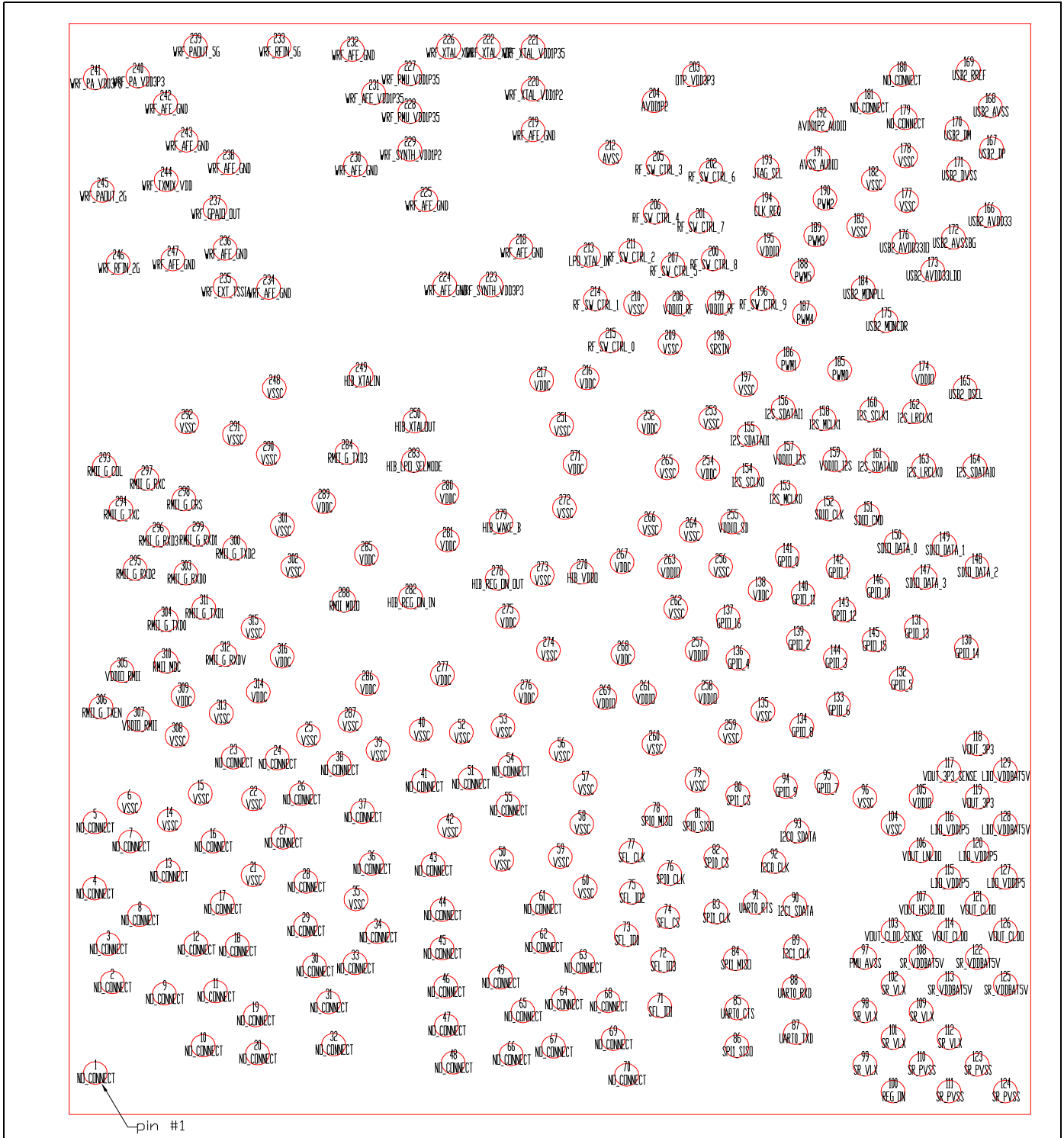

9.1 Bump List

Table 9 contains the WLCSP bump names.

Table 9. WLCSP Bump Names

Bump	Name
1	NO_CONNECT
2	NO_CONNECT
3	NO_CONNECT
4	NO_CONNECT
5	NO_CONNECT
6	VSSC
7	NO_CONNECT
8	NO_CONNECT
9	NO_CONNECT
10	NO_CONNECT
11	NO_CONNECT
12	NO_CONNECT
13	NO_CONNECT
14	VSSC
15	VSSC
16	NO_CONNECT
17	NO_CONNECT
18	NO_CONNECT
19	NO_CONNECT
20	NO_CONNECT
21	VSSC
22	VSSC
23	NO_CONNECT
24	NO_CONNECT
25	VSSC
26	NO_CONNECT
27	NO_CONNECT
28	NO_CONNECT
29	NO_CONNECT
30	NO_CONNECT
31	NO_CONNECT
32	NO_CONNECT
33	NO_CONNECT
34	NO_CONNECT
35	VSSC
36	NO_CONNECT
37	NO_CONNECT
38	NO_CONNECT
39	VSSC

Bump	Name
40	VSSC
41	NO_CONNECT
42	VSSC
43	NO_CONNECT
44	NO_CONNECT
45	NO_CONNECT
46	NO_CONNECT
47	NO_CONNECT
48	NO_CONNECT
49	NO_CONNECT
50	VSSC
51	NO_CONNECT
52	VSSC
53	VSSC
54	NO_CONNECT
55	NO_CONNECT
56	VSSC
57	VSSC
58	VSSC
59	VSSC
60	VSSC
61	NO_CONNECT
62	NO_CONNECT
63	NO_CONNECT
64	NO_CONNECT
65	NO_CONNECT
66	NO_CONNECT
67	NO_CONNECT
68	NO_CONNECT
69	NO_CONNECT
70	NO_CONNECT
71	SFL_IO1
72	SFL_IO3
73	SFL_IO0
74	SFL_CS
75	SFL_IO2
76	SPI0_CLK
77	SFL_CLK
78	SPI0_MISO

Bump	Name
79	VSSC
80	SPI1_CS
81	SPI0_SISO
82	SPI0_CS
83	SPI1_CLK
84	SPI1_MISO
85	UART0_CTS
86	SPI1_SISO
87	UART0_TXD
88	UART0_RXD
89	I2C1_CLK
90	I2C1_SDATA
91	UART0_RTS
92	I2C0_CLK
93	I2C0_SDATA
94	GPIO_9
95	GPIO_7
96	VSSC
97	PMU_AVSS
98	SR_VLX
99	SR_VLX
100	REG_ON
101	SR_VLX
102	SR_VLX
103	VOUT_CLDO_SENSE
104	VSSC
105	VDDIO
106	VOUT_LNLDO
107	VOUT_BBPLL0UT
108	SR_VDDBAT5V
109	SR_VLX
110	SR_PVSS
111	SR_PVSS
112	SR_VLX
113	SR_VDDBAT5V
114	VOUT_CLDO
115	LDO_VDD1P5
116	LDO_VDD1P5
117	VOUT_3P3_SENSE
118	VOUT_3P3
119	VOUT_3P3
120	LDO_VDD1P5

Bump	Name
121	VOUT_CLDO
122	SR_VDDBAT5V
123	SR_PVSS
124	SR_PVSS
125	SR_VDDBAT5V
126	VOUT_CLDO
127	LDO_VDD1P5
128	LDO_VDDBAT5V
129	LDO_VDDBAT5V
130	GPIO_14
131	GPIO_13
132	GPIO_5
133	GPIO_6
134	GPIO_8
135	VSSC
136	GPIO_4
137	GPIO_16
138	VDDC
139	GPIO_2
140	GPIO_11
141	GPIO_0
142	GPIO_1
143	GPIO_12
144	GPIO_3
145	GPIO_15
146	GPIO_10
147	SDIO_DATA_3
148	SDIO_DATA_2
149	SDIO_DATA_1
150	SDIO_DATA_0
151	SDIO_CMD
152	SDIO_CLK
153	I2S_MCLK0
154	I2S_SCLK0
155	I2S_SDATA01
156	I2S_SDATA11
157	VDDIO_I2S
158	I2S_MCLK1
159	VDDIO_I2S
160	I2S_SCLK1
161	I2S_SDATA00
162	I2S_LRCLK1

Bump	Name
163	I2S_LRCLK0
164	I2S_SDATAI0
165	USB2_DSEL
166	USB2_AVDD33
167	USB2_DP
168	USB2_AVSS
169	USB2_RREF
170	USB2_DM
171	USB2_DVSS
172	USB2_AVSSBG
173	USB2_AVDD33LDO
174	VDDIO
175	USB2_MONCDR
176	USB2_AVDD33IO
177	VSSC
178	VSSC
179	NO_CONNECT
180	NO_CONNECT
181	NO_CONNECT
182	VSSC
183	VSSC
184	USB2_MONPLL
185	PWM0
186	PWM1
187	PWM4
188	PWM5
189	PWM3
190	PWM2
191	AVSS_AUDIO
192	AVDD1P2_AUDIO
193	JTAG_SEL
194	CLK_REQ
195	VDDIO
196	RF_SW_CTRL_9
197	VSSC
198	SRSTN
199	VDDIO_RF
200	RF_SW_CTRL_8
201	RF_SW_CTRL_7
202	RF_SW_CTRL_6
203	OTP_VDD3P3
204	AVDD1P2

Bump	Name
205	RF_SW_CTRL_3
206	RF_SW_CTRL_4
207	RF_SW_CTRL_5
208	VDDIO_RF
209	VSSC
210	VSSC
211	RF_SW_CTRL_2
212	AVSS
213	LPO_XTAL_IN
214	RF_SW_CTRL_1
215	RF_SW_CTRL_0
216	VDDC
217	VDDC
218	WRF_AFE_GND
219	WRF_AFE_GND
220	WRF_XTAL_VDD1P2
221	WRF_XTAL_VDD1P35
222	WRF_XTAL_XOP
223	WRF_SYNTH_VDD3P3
224	WRF_AFE_GND
225	WRF_AFE_GND
226	WRF_XTAL_XON
227	WRF_PMU_VDD1P35
228	WRF_PMU_VDD1P35
229	WRF_SYNTH_VDD1P2
230	WRF_AFE_GND
231	WRF_AFE_VDD1P35
232	WRF_AFE_GND
233	WRF_RFIN_5G
234	WRF_AFE_GND
235	WRF_EXT_TSSIA
236	WRF_AFE_GND
237	WRF_GPAIO_OUT
238	WRF_AFE_GND
239	WRF_PAOUT_5G
240	WRF_PA_VDD3P3
241	WRF_PA_VDD3P3
242	WRF_AFE_GND
243	WRF_AFE_GND
244	WRF_TXMIX_VDD
245	WRF_PAOUT_2G
246	WRF_RFIN_2G

Bump	Name
247	WRF_AFE_GND
248	VSSC
249	HIB_XTALIN
250	HIB_XTALOUT
251	VSSC
252	VDDC
253	VSSC
254	VDDC
255	VDDIO_SD
256	VSSC
257	VDDIO
258	VDDIO
259	VSSC
260	VSSC
261	VDDIO
262	VSSC
263	VDDIO
264	VSSC
265	VSSC
266	VSSC
267	VDDC
268	VDDC
269	VDDIO
270	HIB_VDDO
271	VDDC
272	VSSC
273	VSSC
274	VSSC
275	VDDC
276	VDDC
277	VDDC
278	HIB_REG_ON_OUT
279	HIB_WAKE_B
280	VDDC
281	VDDC
282	HIB_REG_ON_IN
283	HIB_LPO_SELMODE
284	RMII_G_TXD3
285	VDDC
286	VDDC
287	VSSC
288	RMII_MDIO

Bump	Name
289	VDDC
290	VSSC
291	VSSC
292	VSSC
293	RMII_G_COL
294	RMII_G_TXC
295	RMII_G_RXD2
296	RMII_G_RXD3
297	RMII_G_RXC
298	RMII_G_CRS
299	RMII_G_RXD1
300	RMII_G_TXD2
301	VSSC
302	VSSC
303	RMII_G_RXD0
304	RMII_G_TXD0
305	VDDIO_RMII
306	RMII_G_TXEN
307	VDDIO_RMII
308	VSSC
309	VDDC
310	RMII_MDC
311	RMII_G_TXD1
312	RMII_G_RXDV
313	VSSC
314	VDDC
315	VSSC
316	VDDC

9.2 Signal Descriptions

Table 10 provides the signal name, type, and description for each CYW54907 bump. The symbols shown under Type indicate pin directions (I/O = bidirectional, I = input, and O = output) and the internal pull-up/pull-down characteristics (PU = weak internal pull-up resistor and PD = weak internal pull-down resistor), if any.

Table 10. Signal Descriptions

Bump Number	Signal Name	Type	Description
Cypress Serial Control (CSC) Interfaces			
92	I ² C0_CLK	O	CSC master clock.
93	I ² C0_SDATA	I/O	CSC serial data
89	I ² C1_CLK	O	CSC master clock
90	I ² C1_SDATA	I/O	CSC serial data
Clocks			
222	WRF_XTAL_XOP	I	XTAL oscillator input.
226	WRF_XTAL_XON	O	XTAL oscillator output.
213	LPO_XTAL_IN	I	External sleep clock input (32.768 kHz).
249	HIB_XTALIN	I	3.3V 32 kHz crystal input
250	HIB_XTALOUT	O	3.3V 32 kHz crystal output
194	CLK_REQ	O	Reference clock request
Ethernet MAC Interface (MII/RMII)			
297	RMII_G_RXC	I	MII receive clock
293	RMII_G_COL	I	MII collision detection
298	RMII_G_CRS	I	MII carrier sense
294	RMII_G_TXC	I	MII/RMII transmit clock
304	RMII_G_TXD0	O	MII/RMII transmit signal
311	RMII_G_TXD1	O	MII/RMII transmit signal
300	RMII_G_TXD2	O	MII transmit signal
284	RMII_G_TXD3	O	MII transmit signal
303	RMII_G_RXD0	I	MII/RMII receive signal
299	RMII_G_RXD1	I	MII/RMII receive signal
295	RMII_G_RXD2	I	MII receive signal
296	RMII_G_RXD3	I	MII receive signal
288	RMII_MDIO	I/O	MII/RMII management data
310	RMII_MDC	O	MII/RMII management clock
306	RMII_G_TXEN	O	MII/RMII transmit enable
312	RMII_G_RXDV	I	MII/RMII receive data valid

Table 10. Signal Descriptions (Cont.)

Bump Number	Signal Name	Type	Description
GPIO Interface (WLAN)			
141	GPIO_0	I/O	Programmable GPIO pins.
142	GPIO_1	I/O	
139	GPIO_2	I/O	
144	GPIO_3	I/O	
136	GPIO_4	I/O	
132	GPIO_5	I/O	
133	GPIO_6	I/O	
95	GPIO_7	I/O	
134	GPIO_8	I/O	
94	GPIO_9	I/O	
146	GPIO_10	I/O	
140	GPIO_11	I/O	
143	GPIO_12	I/O	
131	GPIO_13	I/O	
130	GPIO_14	I/O	
145	GPIO_15	I/O	
137	GPIO_16	I/O	
Ground			
218, 219, 224, 225, 230, 232, 234, 236, 238, 242, 243, 247	WRF_AFE_GND	GND	AFE ground
6, 14, 15, 21, 22, 25, 35, 39, 40, 42, 50, 52, 53, 56–60, 79, 96, 104, 135, 177, 178, 182, 183, 197, 209, 210, 248, 251, 253, 256, 259, 260, 262, 264–266, 272–274, 287, 290–292, 301, 302, 308, 313, 315	VSSC	GND	Core ground for WLAN and APP sections
110, 111, 123, 124	SR_PVSS	GND	Power ground
97	PMU_AVSS	GND	Quiet ground
212	AVSS	GND	Baseband PLL ground
191	AVSS_AUDIO	GND	AUDIO PLL ground
168	USB2_AVSS	GND	USB 2.0 analog ground
172	USB2_AVSSBG	GND	USB 2.0 analog ground
171	USB2_DVSS	GND	USB 2.0 digital ground
Hibernation Block, Power-Down/Power-Up, and Reset			
100	REG_ON	I	Used by PMU to power up or power down the internal CYW54907 regulators used by the WLAN and APP sections. Also, when deasserted, this pin holds the WLAN and APP sections in reset. This pin has an internal 200 kΩ pull-down resistor that is enabled by default. It can be disabled through programming.
282	HIB_REG_ON_IN	I	Used by the hibernation block to power up or power down the internal CYW54907 regulators. For applications that use the hibernation block, HIB_REG_ON_OUT must connect to REG_ON. Also, when deasserted, this pin holds the WLAN and APP sections in reset.
278	HIB_REG_ON_OUT	O	REG_ON output signal generated by the hibernation block.

Table 10. Signal Descriptions (Cont.)

Bump Number	Signal Name	Type	Description
279	HIB_WAKE_B	I	Wake up chip from hibernation mode.
283	HIB_LPO_SELMODE	I	Select precise or coarse 32 kHz clock.
198	SRSTN	I	System reset. This active-low signal resets the backplanes.
I²S Interface			
153	I ² S_MCLK0	I/O	M clock
154	I ² S_SCLK0	I/O	S clock
163	I ² S_LRCLK0	I/O	LR clock
164	I ² S_SDATAI0	I	I ² S data input
161	I ² S_SDATAO0	O	I ² S data output
158	I ² S_MCLK1	I/O	M clock
160	I ² S_SCLK1	I/O	S clock
162	I ² S_LRCLK1	I/O	LR clock
156	I ² S_SDATAI1	I	I ² S data input
155	I ² S_SDATAO1	O	I ² S data output
JTAG Interface			
193	JTAG_SEL	I	JTAG select. This pin must be connected to ground if the JTAG interface is not used.
No Connects			
1–5, 7–13, 16–20, 23, 24, 26–34, 36–38, 41, 43–49, 51, 54, 55, 61–70, 179–181	NO_CONNECT	–	No connect
Power Supplies (Miscellaneous)			
203	OTP_VDD3P3	PWR	OTP 3.3V supply
138, 216, 217, 252, 254, 267, 268, 271, 275–277, 280, 281, 285, 286, 289, 309, 314, 316	VDDC	PWR	1.2V core supply for WLAN
105, 174, 195, 257, 258, 261, 263, 269	VDDIO	PWR	I/O supply
199, 208	VDDIO_RF	PWR	I/O supply for RF switch control pads (3.3V).
157, 159	VDDIO_I2S	PWR	I/O supply for I ² S
305, 307	VDDIO_RMII	PWR	I/O supply for RMII
255	VDDIO_SD	PWR	I/O supply for SDIO
270	HIB_VDDO	PWR	I/O supply for hibernation block
204	AVDD1P2	PWR	1.2V supply for baseband PLL
192	AVDD1P2_AUDIO	PWR	1.2V supply for audio PLL
166	USB2_AVDD33	PWR	3.3V supply for USB 2.0
173	USB2_AVDD33LDO	PWR	3.3V supply for USB 2.0
176	USB2_AVDD33IO	PWR	3.3V supply for USB 2.0
Power Supplies (WLAN)			
223	WRF_SYNTNTH_VDD3P3	PWR	Synthesizer VDD 3.3V supply
240, 241	WRF_PA_VDD3P3	PWR	2.4 GHz and 5 GHz PA 3.3V VBAT supply
227, 228	WRF_PMU_VDD1P35	PWR	PMU 1.35V supply
244	WRF_TXMIX_VDD	PWR	3.3V supply for TX mixer
229	WRF_SYNTNTH_VDD1P2	PWR	1.2V supply for synthesizer
231	WRF_AFE_VDD1P35	PWR	1.35V supply for the analog front end (AFE)

Table 10. Signal Descriptions (Cont.)

Bump Number	Signal Name	Type	Description
PWM Interface			
185	PWM0	O	Pulse width modulation bit 0.
186	PWM1	O	Pulse width modulation bit 1
190	PWM2	O	Pulse width modulation bit 2
189	PWM3	O	Pulse width modulation bit 3
187	PWM4	O	Pulse width modulation bit 4
188	PWM5	O	Pulse width modulation bit 5
RF Signal Interface (WLAN)			
246	WRF_RFIN_2G	I	2.4 GHz WLAN receiver input
233	WRF_RFIN_5G	I	5 GHz WLAN receiver input
245	WRF_PAOUT_2G	O	2.4 GHz WLAN PA output
239	WRF_PAOUT_5G	O	5 GHz WLAN PA output
235	WRF_EXT_TSSIA	I	5 GHz TSSI input from an optional external power amplifier/power detector
237	WRF_GPAIO_OUT	I/O	Analog GPIO
RF Switch Control Lines			
215	RF_SW_CTRL_0	O	Programmable RF switch control lines. The control lines are programmable via the driver and nvram.txt file.
214	RF_SW_CTRL_1	O	
211	RF_SW_CTRL_2	O	
205	RF_SW_CTRL_3	O	
206	RF_SW_CTRL_4	O	
207	RF_SW_CTRL_5	I/O	
202	RF_SW_CTRL_6	I/O	
201	RF_SW_CTRL_7	I/O	
200	RF_SW_CTRL_8	I/O	
196	RF_SW_CTRL_9	I/O	
SDIO Interface			
152	SDIO_CLK	I/O	SDIO clock
151	SDIO_CMD	I/O	SDIO command line
150	SDIO_DATA_0	I/O	SDIO data line 0
149	SDIO_DATA_1	I/O	SDIO data line 1
148	SDIO_DATA_2	I/O	SDIO data line 2
147	SDIO_DATA_3	I/O	SDIO data line 3
S/PDIF Interface			
Note: Supported via 161 (I2S_SDATA0) and 155 (I2S_SDATA1).			
SPI Flash Interface			
77	SFL_CLK	O	Flash clock
73	SFL_IO0	I/O	Flash data
71	SFL_IO1	I/O	Flash data
75	SFL_IO2	I/O	Flash data
72	SFL_IO3	I/O	Flash data
74	SFL_CS	O	Flash slave select

Table 10. Signal Descriptions (Cont.)

Bump Number	Signal Name	Type	Description
SPI Interfaces			
Note: Each SPI interface can alternatively be configured and used as a CSC interface ^a .			
76	SPI0_CLK	O	SPI clock
78	SPI0_MISO	I	SPI data master in
81	SPI0_SISO	O	SPI data master out
82	SPI0_CS	O	SPI slave select
83	SPI1_CLK	O	SPI clock
84	SPI1_MISO	I	SPI data master in
86	SPI1_SISO	O	SPI data master out
80	SPI1_CS	O	SPI slave select
UART Interface			
85	UART0_CTS	I	UART clear-to-send
91	UART0_RTS	O	UART request-to-send
88	UART0_RXD	I	UART serial input
87	UART0_TXD	O	UART serial output
USB 2.0			
170	USB2_DM	I/O	USB 2.0 data
167	USB2_DP	I/O	USB 2.0 data
169	USB2_RREF	I	USB 2.0 reference resistor connection
175	USB2_MONCDR	O	USB 2.0 CDR monitor
184	USB2_MONPLL	O	USB 2.0 PLL monitor
165	USB2_DSEL	I	USB 2.0 host and device mode selection
Voltage Regulators (Integrated)			
108, 113, 122, 125	SR_VDDBAT5V	I	VBAT.
98, 99, 101, 102, 109, 112	SR_VLX	O	CBUCK switching regulator output
115, 116, 120, 127	LDO_VDD1P5	I	LNLDO input
128, 129	LDO_VDDBAT5V	I	LDO VBAT
221	WRF_XTAL_VDD1P35	I	XTAL LDO input (1.35V)
220	WRF_XTAL_VDD1P2	O	XTAL LDO output (1.2V)
106	VOUT_LNLDO	O	Output of LNLDO
114, 121, 126	VOUT_CLDO	O	Output of core LDO
118, 119	VOUT_3P3	O	LDO 3.3V output
117	VOUT_3P3_SENSE	O	Voltage sense pin for LDO 3.3V output
103	VOUT_CLDO_SENSE	O	Voltage sense pin for core LDO
107	VOUT_BBPLLOUT	O	Output of baseband PLL

a. The SPI blocks can be re-purposed as I²C, however the WICED SDK does not support this. Certain I²C features are not available when using the SPI blocks as I²C. Therefore Cypress does not recommend using the SPI blocks as I²C interfaces.

10. GPIO Signals and Strapping Options

10.1 Overview

This section describes GPIO signals and strapping options. The pins are sampled at power-on reset (POR) to determine various operating modes. Sampling occurs a few milliseconds after an internal POR or deassertion of the external POR. After the POR, each pin assumes the GPIO or alternative function specified in [Table 12](#). Each strapping option pin has an internal pull-up (PU) or pull-down (PD) resistor that determines the default mode. To change the mode, connect an external PU resistor to VDDIO or a PD resistor to ground, using a 10 kΩ resistor or less.

Note: Refer to the reference board schematics for more information.

10.2 Weak Pull-Down and Pull-Up Resistances

At VDDO = 3.3V ±10%, the minimum, typical, and maximum weak pull-down resistances (for a pin voltage of VDDO) are 37.99 kΩ, 44.57 kΩ, and 51.56 kΩ, respectively. At VDDO = 3.3V ±10%, the minimum, typical, and maximum weak pull-up resistances (for a pin voltage of 0V) are 34.73 kΩ, 39.58 kΩ, and 44.51 kΩ, respectively.

10.3 Strapping Options

[Table 11](#) provides the strapping options.

Table 11. Strapping Options

Pin Name	Strap	Bump #	Default Internal Pull During Strap	Description
GPIO_1	GSPI_MODE	142	PD	Enable gSPI interface
GPIO_7	WCPU_BOOT_MODE	95	PD	Boot from SoC SROM or SoC SRAM
GPIO_11	ACPU_BOOT_MODE	140	PD	Boot from tightly coupled memory (TCM) ROM or TCM RAM
GPIO_13	SDIO_MODE	131	PD	Select either SDIO host mode or SDIO device mode
GPIO_15	VTRIM_EN	145	PD	Enable PMU voltage trimming
RF_SW_CTRL_5	DAP_CLK_SEL	207	PD	Select XTAL clock or the test clock (tck) for the debug access port (DAP)
RF_SW_CTRL_7	RSRC_INIT_MODE	201	PD	PMU resource initialization mode selection

10.4 Alternate GPIO Signal Functions

Table 12 provides the alternate signal functions of the GPIO signals.

Table 12. Alternate GPIO Signal Functions

GPIO	Default	JTAG_SEL	Default Pull	HOLD/PDLOW/PDHIGH	Strap	Comments
GPIO_0	USB20H_CTL	–	No pull	HOLD	–	8 mA
GPIO_1	–	–	Down	HOLD	GSPI_MODE	8 mA
GPIO_2	GCI_GPIO(0)	JTAG_TCK	No pull	HOLD	–	8 mA
GPIO_3	GCI_GPIO(1)	JTAG_TMS	No pull	HOLD	–	8 mA
GPIO_4	GCI_GPIO(2)	JTAG_TDI	No pull	HOLD	–	8 mA
GPIO_5	GCI_GPIO(3)	JTAG_TDO	No pull	HOLD	–	8 mA
GPIO_6	GCI_GPIO(4)	JTAG_TRST	No pull	HOLD	–	8 mA
GPIO_7	–	–	Down	HOLD	WCPU_BOOT_MODE	8 mA
GPIO_8	GPIO_8	–	No pull	HOLD	–	8 mA
GPIO_9	GPIO_9	–	Down	HOLD	–	8 mA
GPIO_10	GPIO_10	–	No pull	HOLD	–	8 mA
GPIO_11	–	–	Down	HOLD	ACPU_BOOT_MODE	8 mA
GPIO_12	GPIO_12	–	No pull	HOLD	–	8 mA
GPIO_13	–	–	Down	HOLD	SDIO_MODE	8 mA
GPIO_14	GPIO_14	–	No pull	HOLD	–	8 mA
GPIO_15	–	–	Down	HOLD	VTRIM_EN	8 mA
GPIO_16	–	–	No pull	HOLD	–	8 mA

11. Pin Multiplexing

Table 13 shows the pin multiplexing functions.

Table 13. Pin Multiplexing

Pin	Function										
	1	2	3	4	5	6	7	8	9	10	11
GPIO_0	GPIO_0	UART0_RXD	I2C1_SDAT A	PWM0	SPI1_MISO	PWM2	GPIO_12	GPIO_8	–	PWM4	USB20H_C TL
GPIO_1	GPIO_1	UART0_TXD	I2C1_CLK	PWM1	SPI1_CLK	PWM3	GPIO_13	GPIO_9	–	PWM5	–
GPIO_2	GPIO_2	–	–	GCI_GPIO_0	–	–	–	–	TCK	–	–
GPIO_3	GPIO_3	–	–	GCI_GPIO_1	–	–	–	–	TMS	–	–
GPIO_4	GPIO_4	–	–	GCI_GPIO_2	–	–	–	–	TDI	–	–
GPIO_5	GPIO_5	–	–	GCI_GPIO_3	–	–	–	–	TDO	–	–
GPIO_6	GPIO_6	–	–	GCI_GPIO_4	–	–	–	–	TRST_L	–	–
GPIO_7	GPIO_7	UART0_RTS_OUT	PWM1	PWM3	SPI1_CS	I2C1_CLK	GPIO_15	GPIO_11	PMU_TEST O	–	PWM5
GPIO_8	GPIO_8	SPI1_MISO	PWM2	PWM4	UART0_RXD	–	GPIO_16	GPIO_12	TAP_SEL_P	I2C1_SDAT A	PWM0
GPIO_9	GPIO_9	SPI1_CLK	PWM3	PWM5	UART0_TXD	–	GPIO_0	GPIO_13	–	I2C1_CLK	PWM1
GPIO_10	GPIO_10	SPI1_MOSI	PWM4	I2C1_SDAT A	UART0_CTS_IN	PWM0	GPIO_1	GPIO_14	PWM2	SDIO_SEP_I NT	SDIO_SEP_I NT_OD
GPIO_11	GPIO_11	SPI1_CS	PWM5	I2C1_CLK	UART0_RTS_OUT	PWM1	GPIO_7	GPIO_15	PWM3	–	–
GPIO_12	GPIO_12	I2C1_SDAT A	UART0_RXD	SPI1_MISO	PWM2	PWM4	GPIO_8	GPIO_16	PWM0	SDIO_SEP_I NT_OD	SDIO_SEP_I NT
GPIO_13	GPIO_13	I2C1_CLK	UART0_TXD	SPI1_CLK	PWM3	PWM5	GPIO_9	GPIO_0	PWM1	–	–
GPIO_14	GPIO_14	PWM0	UART0_CTS_IN	SPI1_MOSI	I2C1_SDAT A	–	GPIO_10	–	PWM4	–	PWM2

Table 13. Pin Multiplexing

Pin	Function										
	1	2	3	4	5	6	7	8	9	10	11
GPIO_15	GPIO_15	PWM1	UART0_RTS_OUT	SPI1_CS	I ² C1_CLK	–	GPIO_11	GPIO_7	PWM5	–	PWM3
GPIO_16	GPIO_16	UART0_CTS_IN	PWM0	PWM2	SPI1_MOSI	I ² C1_SDAT A	GPIO_14	GPIO_10	RF_DISABLE_L	–	PWM4
SDIO_CLK	SDIO_CLK	–	–	–	–	–	–	–	SDIO_AOS CLK	–	–
SDIO_CMD	SDIO_CMD	–	–	–	–	–	–	–	SDIO_AOS CMD	–	–
SDIO_DATA_0	SDIO_D0	–	–	–	–	–	–	–	SDIO_AOS D0	–	–
SDIO_DATA_1	SDIO_D1	–	–	–	–	–	–	–	SDIO_AOS D1	–	–
SDIO_DATA_2	SDIO_D2	–	–	–	–	–	–	–	SDIO_AOS D2	–	–
SDIO_DATA_3	SDIO_D3	–	–	–	–	–	–	–	SDIO_AOS D3	–	–
RF_SW_CTRL_5	RF_SW_CTRL_5	GCI_GPIO_5	–	–	–	–	–	–	–	–	–
RF_SW_CTRL_6	RF_SW_CTRL_6	UART_DBG_RX ^a	SECI_IN ^a	–	–	–	–	–	–	–	–
RF_SW_CTRL_7	RF_SW_CTRL_7	UART_DBG_TX ^a	SECI_OUT ^a	–	–	–	–	–	–	–	–
RF_SW_CTRL_8	RF_SW_CTRL_8	SECI_IN ^a	UART_DBG_RX ^a	–	–	–	–	–	–	–	–
RF_SW_CTRL_9	RF_SW_CTRL_9	SECI_OUT ^a	UART_DBG_TX ^a	–	–	–	–	–	–	–	–
PWM0	PWM0	GPIO_2	GPIO_18	–	–	–	–	–	–	–	–
PWM1	PWM1	GPIO_3	GPIO_19	–	–	–	–	–	–	–	–
PWM2	PWM2	GPIO_4	GPIO_20	–	–	–	–	–	–	–	–

Table 13. Pin Multiplexing

Pin	Function										
	1	2	3	4	5	6	7	8	9	10	11
PWM3	PWM3	GPIO_5	GPIO_21	–	–	–	–	–	–	–	–
PWM4	PWM4	GPIO_6	GPIO_22	–	–	–	–	–	–	–	–
PWM5	PWM5	GPIO_8	GPIO_23	–	–	–	–	–	–	–	–
SPI0_MISO	SPI0_MISO	GPIO_17	GPIO_24	–	–	–	–	–	–	–	–
SPI0_CLK	SPI0_CLK	GPIO_18	GPIO_25	–	–	–	–	–	–	–	–
SPI0_MOSI	SPI0_MOSI	GPIO_19	GPIO_26	–	–	–	–	–	–	–	–
SPI0_CS	SPI0_CS	GPIO_20	GPIO_27	–	–	–	–	–	–	–	–
I ² C0_SDATA	I ² C0_SDATA	GPIO_21	GPIO_28	–	–	–	–	–	–	–	–
I ² C0_CLK	I ² C0_CLK	GPIO_22	GPIO_29	–	–	–	–	–	–	–	–
I ² S_MCLK0	I ² S_MCLK0	GPIO_23	GPIO_0	–	–	–	–	–	–	–	–
I ² S_SCLK0	I ² S_SCLK0	GPIO_24	GPIO_2	–	–	–	–	–	–	–	–
I ² S_LRCLK0	I ² S_LRCLK0	GPIO_25	GPIO_3	–	–	–	–	–	–	–	–
I ² S_SDATAI0	I ² S_SDATAI0	GPIO_26	GPIO_4	–	–	–	–	–	–	–	–
I ² S_SDATAO0	I ² S_SDATAO0	GPIO_27	GPIO_5	–	–	–	–	–	–	–	–
I ² S_SDATAO1	I ² S_SDATAO1	GPIO_28	GPIO_6	–	–	–	–	–	–	–	–
I ² S_SDATAI1	I ² S_SDATAI1	GPIO_29	GPIO_8	–	–	–	–	–	–	–	–
I ² S_MCLK1	I ² S_MCLK1	GPIO_30	GPIO_17	–	–	–	–	–	–	–	–
I ² S_SCLK1	I ² S_SCLK1	GPIO_31	GPIO_30	–	–	–	–	–	–	–	–
I ² S_LRCLK1	I ² S_LRCLK1	GPIO_0	GPIO_31	–	–	–	–	–	–	–	–

a. UART_DBG_TX and UART_DBG_RX are for UART1 mentioned in section 5.10 and in the reference schematics. SECI_IN and SECI_OUT are for UART2 mentioned in section 5.10 and in the reference schematics.

12. I/O States

Table 14 provides I/O state information for the signals listed.

The following notations are used in Table 14:

- I: Input signal
- O: Output signal
- I/O: Input/Output signal
- PU = Pulled up
- PD = Pulled down
- NoPull = Neither pulled up nor pulled down

Table 14. I/O States

Ball Name	I/O	Keeper ^a	Active Mode	Low Power State/Sleep (All Power Present)	Power-down ^b (REG_ON Held Low)	Out-of-Reset; Before Software Download (REG_ON High)	Power Rail
HIB_REG_ON_IN	I	N	Input; PD (Pull-down can be disabled.)	Input; PD (Pull-down can be disabled.)	Input	Input	–
REG_ON	I	N	Input; PD (Pull-down can be disabled.)	Input; PD (Pull-down can be disabled.)	Input; PD (of 200 kΩ)	Input; PD (of 200 kΩ)	–
CLK_REQ	I/O	Y	Open drain or push-pull (programmable). Active high.	Open drain or push-pull (programmable). Active high.	High-Z, NoPull	Open drain; active high	VDDO
GPIO_0	I/O	Y	Input/Output; PU, PD, or NoPull (programmable [Default: PD])	Input/Output; PU, PD, or NoPull (programmable [Default: PD])	High-Z, NoPull	Input; PD	VDDIO
GPIO_1	I/O	Y	Input/Output; PU, PD, or NoPull (programmable [Default: NoPull])	Input/Output; PU, PD, or NoPull (programmable [Default: NoPull])	High-Z, NoPull	Input; NoPull	VDDIO
GPIO_2	I/O	Y	Input/Output; PU, PD, or NoPull (programmable [Default: NoPull])	Input/Output; PU, PD, or NoPull (programmable [Default: NoPull])	High-Z, NoPull	Input; NoPull	VDDIO
GPIO_3	I/O	Y	Input/Output; PU, PD, or NoPull (programmable [Default: PD])	Input/Output; PU, PD, or NoPull (programmable [Default: PD])	High-Z, NoPull	Input; PD	VDDIO
GPIO_4	I/O	Y	Input/Output; PU, PD, or NoPull (programmable [Default: NoPull])	Input/Output; PU, PD, or NoPull (programmable [Default: NoPull])	High-Z, NoPull	Input; NoPull	VDDIO
GPIO_5	I/O	Y	Input/Output; PU, PD, or NoPull (programmable [Default: PD])	Input/Output; PU, PD, or NoPull (programmable [Default: PD])	High-Z, NoPull	Input; PD	VDDIO

Table 14. I/O States

Ball Name	I/O	Keeper ^a	Active Mode	Low Power State/Sleep (All Power Present)	Power-down ^b (REG_ON Held Low)	Out-of-Reset; Before Software Download (REG_ON High)	Power Rail
GPIO_6	I/O	Y	Input/Output; PU, PD, or NoPull (programmable [Default: NoPull])	Input/Output; PU, PD, or NoPull (programmable [Default: NoPull])	High-Z, NoPull	Input; NoPull	VDDIO
GPIO_7	I/O	Y	Input/Output; PU, PD, or NoPull (programmable [Default: NoPull])	Input/Output; PU, PD, or NoPull (programmable [Default: NoPull])	High-Z, NoPull	Input; NoPull	VDDIO
GPIO_8	I/O	Y	Input/Output; PU, PD, or NoPull (programmable [Default: PD])	Input/Output; PU, PD, or NoPull (programmable [Default: PD])	High-Z, NoPull	Input; PD	VDDIO
GPIO_9	I/O	Y	Input/Output; PU, PD, or NoPull (programmable [Default: PD])	Input/Output; PU, PD, or NoPull (programmable [Default: PD])	High-Z, NoPull	Input; PD	VDDIO
GPIO_10	I/O	Y	Input/Output; PU, PD, or NoPull (programmable [Default: NoPull])	Input/Output; PU, PD, or NoPull (programmable [Default: NoPull])	High-Z, NoPull	Input; NoPull	VDDIO
GPIO_11	I/O	Y	Input/Output; PU, PD, or NoPull (programmable [Default: PD])	Input/Output; PU, PD, or NoPull (programmable [Default: PD])	High-Z, NoPull	Input; PD	VDDIO
GPIO_12	I/O	Y	Input/Output; PU, PD, or NoPull (programmable [Default: NoPull])	Input/Output; PU, PD, or NoPull (programmable [Default: NoPull])	High-Z, NoPull	Input; NoPull	VDDIO
GPIO_13	I/O	Y	Input/Output; PU, PD, or NoPull (programmable [Default: NoPull])	Input/Output; PU, PD, or NoPull (programmable [Default: NoPull])	High-Z, NoPull	Input; NoPull	VDDIO
GPIO_14	I/O	Y	Input/Output; PU, PD, or NoPull (programmable [Default: NoPull])	Input/Output; PU, PD, or NoPull (programmable [Default: NoPull])	High-Z, NoPull	Input; NoPull	VDDIO
GPIO_15	I/O	Y	Input/Output; PU, PD, or NoPull (programmable [Default: NoPull])	Input/Output; PU, PD, or NoPull (programmable [Default: NoPull])	High-Z, NoPull	Input; NoPull	VDDIO
GPIO_16	I/O	Y	Input/Output; PU, PD, or NoPull (programmable [Default: NoPull])	Input/Output; PU, PD, or NoPull (programmable [Default: NoPull])	High-Z, NoPull	Input; NoPull	VDDIO
RF_SW_CTRL (0 to 9)	I/O	Y	Output; NoPull	Output; NoPull	High-Z	Output; NoPull	VDDIO_RF

a. Keeper column: N = pad has no keeper. Y = pad has a keeper. Keeper is always active except in power-down state. If there is no keeper, and it is an input and there is NoPull, then the pad should be driven to prevent leakage due to floating pad (WL_REG_ON, for example).

b. In the power-down state (xx_REG_ON=0): High-Z; NoPull => the pad is disabled because power is not supplied.

13. Electrical Characteristics

Note: Values in this data sheet are design goals and are subject to change based on the results of device characterization.

13.1 Absolute Maximum Ratings

Caution! The absolute maximum ratings in [Table 15](#) indicate levels where permanent damage to the device can occur, even if these limits are exceeded for only a brief duration. Functional operation is not guaranteed under these conditions. Operation at absolute maximum conditions for extended periods can adversely affect long-term reliability of the device.

Table 15. Absolute Maximum Ratings

Parameter	Symbol	Value	Unit
DC supply for VBAT and PA driver supply ^a	VBAT	-0.5 to +5.5	V
DC supply voltage for digital I/O	VDDIO	-0.5 to 3.9	V
DC supply voltage for I ² S I/O	VDDIO_I2S	-0.5 to 3.9	V
DC supply voltage for RF switch I/O	VDDIO_RF	-0.5 to 3.9	V
DC supply voltage for Ethernet I/O	VDDIO_RMII	-0.5 to 3.9	V
DC supply voltage for SDIO I/O	VDDIO_SD	-0.5 to 3.9	V
DC input supply voltage for CLDO, LNLDO, and BBPLL LDO ^b	-	-0.5 to 1.575	V
3.3V DC supply for USB	USB2_AVDD33 USB2_AVDD33LDO USB2_AVDD33IO	-0.5 to 3.9	V
3.3V DC supply voltage for RF analog ^c	VDD3P3RF	-0.5 to 3.6	V
1.35V DC supply voltage for RF analog ^d	VDD1P35RF	-0.5 to 1.5	V
1.2V DC supply voltage for RF analog ^e	VDD1P2RF	-0.5 to 1.26	V
1.2V DC supply voltage for analog circuits ^f	VDD1P2A	-0.5 to 1.26	V
DC supply voltage for the core ^g	VDDC	-0.5 to 1.32	V
DC supply voltage for OTP memory	OTP_VDD3P3	-0.5 to 3.9	V
Maximum undershoot voltage for I/O	V _{undershoot}	-0.5	V
Maximum junction temperature	T _j	125	°C

- a. For the SR_VDDBAT5V and LDO_VDDBAT5V supplies.
- b. For the LDO_VDD1P5 and WRF_XTAL_VDD1P35 supplies.
- c. For the WRF_SYNT_H_VDD3P3, WRF_PA_VDD3P3, and WRF_TXMIX_VDD supplies.
- d. For WRF_P_{MU}_VDD1P35 and WRF_A_{FE}_VDD1P35 supplies.
- e. For the WRF_SYNT_H_VDD1P2 supply.
- f. For the AVDD1P2_AUDIO, AVDD1P2, and HSIC_AVDD12 supplies.
- g. For the VDD, HSIC_DVDD12, and HSIC2_DVDD2 supplies.

13.2 Environmental Ratings

The environmental ratings are shown in [Table 16](#).

Table 16. Environmental Ratings

Characteristic	Value	Units	Conditions/Comments
Ambient temperature (T _A)	-30 to +85	°C	Functional operation
Storage temperature	-40 to +125	°C	-
Relative humidity	Less than 60	%	Storage
	Less than 85	%	Operation

13.3 Electrostatic Discharge Specifications

Extreme caution must be exercised to prevent electrostatic discharge (ESD) damage. Proper use of wrist and heel grounding straps to discharge static electricity is required when handling these devices. Always store unused material in its antistatic packaging.

Table 17. ESD Specifications

Pin Type	Symbol	Condition	ESD Rating	Unit
ESD	ESD_HAND_HBM	Human body model contact discharge per JEDEC EID/JESD22-A114	1.5 k	V
CDM	ESD_HAND_CDM	Charged device model contact discharge per JEDEC EIA/JESD22-C101	250	V

13.4 Recommended Operating Conditions and DC Characteristics

Caution! Functional operation is not guaranteed outside of the limits shown in [Table 18](#). Operation outside these limits for extended periods can adversely affect long-term reliability of the device.

Table 18. Recommended Operating Conditions and DC Characteristics

Parameter	Symbol	Value			Unit
		Minimum	Typical	Maximum	
DC supply voltage for VBAT	VBAT	2.3 ^a	3.6	4.8	V
DC supply voltage for digital I/O	VDDIO	1.71	–	3.63	V
DC supply voltage for I ² S I/O	VDDIO_I2S	1.71	–	3.63	V
DC supply voltage for RF switch I/Os	VDDIO_RF ^b	3.13	3.3	3.6	V
DC supply voltage for Ethernet I/O	VDDIO_RMII	1.71	–	3.63	V
DC supply voltage for SDIO I/O	VDDIO_SD	1.71	–	3.63	V
DC input supply voltage for CLDO, LNLDO, and BBPLL LDO	–	1.3	1.35	1.5	V
3.3V DC supply for USB	USB2_AVDD33 USB2_AVDD33LDO USB2_AVDD33IO	2.97	3.3	3.63	V
3.3V DC supply voltage for RF analog	VDD3P3RF ^c	3	3.3	3.45	V
1.35V DC supply voltage for RF analog	VDD1P35RF ^c	1.3	1.35	1.5	V
1.2V DC supply voltage for RF analog	VDD1P2RF ^c	1.1	1.2	1.26	V
1.2V DC supply voltage for analog	VDD1P2A ^c	1.1	1.2	1.26	V
DC supply voltage for core	VDDC	1.14	1.2	1.26	V
DC supply voltage for OTP memory	OTP_VDD3P3 ^b	2.97	3.3	3.63	V
DC supply voltage for TCXO input buffer	WRF_TCXO_VDD ^c	1.62	1.8	1.98	V
Internal POR threshold	Vth_POR	0.4	–	0.7	V
SDIO Interface I/O Pins					
For VDDIO_SD = 1.8V:					
Input high voltage	VIH	1.27	–	–	V
Input low voltage	VIL	–	–	0.58	V
Output high voltage @ 2 mA	VOH	1.40	–	–	V
Output low voltage @ 2 mA	VOL	–	–	0.45	V
For VDDIO_SD = 3.3V:					
Input high voltage	VIH	0.625 × VDDIO	–	–	V

Table 18. Recommended Operating Conditions and DC Characteristics (Cont.)

Parameter	Symbol	Value			Unit
		Minimum	Typical	Maximum	
Input low voltage	VIL	–	–	0.25 × VDDIO	V
Output high voltage @ 2 mA	VOH	0.75 × VDDIO	–	–	V
Output low voltage @ 2 mA	VOL	–	–	0.125 × VDDIO	V
Other Digital I/O Pins					
For VDDIO = 1.8V:					
Input high voltage	VIH	0.65 × VDDIO	–	–	V
Input low voltage	VIL	–	–	0.35 × VDDIO	V
Output high voltage @ 2 mA	VOH	VDDIO – 0.45	–	–	V
Output low voltage @ 2 mA	VOL	–	–	0.45	V
For VDDIO = 3.3V:					
Input high voltage	VIH	2.00	–	–	V
Input low voltage	VIL	–	–	0.80	V
Output high voltage @ 2 mA	VOH	VDDIO – 0.4	–	–	V
Output low voltage @ 2 mA	VOL	–	–	0.40	V
RF Switch Control Output Pins^d					
For VDDIO_RF = 3.3V:					
Output high voltage @ 2 mA	VOH	VDDIO – 0.4	–	–	V
Output low voltage @ 2 mA	VOL	–	–	0.40	V
Input capacitance	C _{IN}	–	–	5	pF

- a. The CYW54907 is functional across this range of voltages. Optimal RF performance specified in the data sheet, however, is guaranteed only for 3V < VBAT < 4.8V.
- b. VDD3P3RF, which is an internally generated supply, can drive this node. There is sufficient current and the appropriate state is maintained during hibernation and sleep cycles.
- c. Internally generated supply.
- d. Programmable 2 mA to 16 mA drive strength. Default is 10 mA.

13.5 Power Supply Segments

The digital I/O's are placed in physical segments. The supply voltage for each segment can be independently selected.

Table 19 shows the power supply segments and the I/O pins associated with each segment.

Table 19. Power Supply Segments

Power Supply Segment	Pins
VDDIO	CLK_REQ, GPIO_0, GPIO_1, GPIO_2, GPIO_3, GPIO_4, GPIO_5, GPIO_6, GPIO_7, GPIO_8, GPIO_9, GPIO_10, GPIO_11, GPIO_12, GPIO_13, GPIO_14, GPIO_15, GPIO_16, I ² C0_CLK, I ² C0_SDATA, I ² C1_CLK, I ² C1_SDATA, JTAG_SEL, PWM0, PWM1, PWM2, PWM3, PWM4, PWM5, SFL_CLK, SFL_CS, SFL_IO0, SFL_IO1, SFL_IO2, SFL_IO3, SPI0_CLK, SPI0_CS, SPI0_MISO, SPI0_SISO, SPI1_CLK, SPI1_CS, SPI1_MISO, SPI1_SISO, SRSTN, UART0_CTS, UART0_RTS, UART0_RXD, UART0_TXD, USB2_DSEL
VDDIO_I ² S	I ² S_LRCLK0, I ² S_LRCLK1, I ² S_MCLK0, I ² S_MCLK1, I ² S_SCLK0, I ² S_SCLK1, I ² S_SDATAI0, I ² S_SDATAI1, I ² S_SDATAO0, I ² S_SDATAO1
VDDIO_RF	RF_SW_CTRL_0, RF_SW_CTRL_1, RF_SW_CTRL_2, RF_SW_CTRL_3, RF_SW_CTRL_4, RF_SW_CTRL_5, RF_SW_CTRL_6, RF_SW_CTRL_7, RF_SW_CTRL_8, RF_SW_CTRL_9
VDDIO_RMII	RMII_G_COL, RMII_G_CRS, RMII_G_RXC, RMII_G_RXD0, RMII_G_RXD1, RMII_G_RXD2, RMII_G_RXD3, RMII_G_RXDV, RMII_G_TXC, RMII_G_TXD0, RMII_G_TXD1, RMII_G_TXD2, RMII_G_TXD3, RMII_G_TXEN, RMII_MDC, RMII_MDIO

13.6 Ethernet MAC Controller (MII/RMII) DC Characteristics

Table 20. MII Recommended Operating Condition

Parameter	Symbol	Minimum	Maximum	Units
Supply voltage	GMAC_VDDIO (MII/RMII)	3.14	3.47	V

13.7 GPIO, UART, and JTAG Interfaces DC Characteristics

Table 21. GPIO, UART, and JTAG Interfaces

Parameter	Symbol	Minimum	Maximum	Units	Conditions
Logic input high voltage	V _{IH}	2.0	VDDIO + 0.5	V	–
Logic input low voltage	V _{IL}	–0.5	0.8	V	–
Logic output high voltage	V _{OH}	2.4	–	V	–
Logic output low voltage	V _{OL}	–	0.4	V	–

14. WLAN RF Specifications

14.1 Introduction

The CYW54907 includes an integrated dual-band direct conversion radio that supports the 2.4 GHz and the 5 GHz bands. This section describes the RF characteristics of the 2.4 GHz and 5 GHz radio.

Note: Values in this section of the data sheet are design goals and are subject to change based on device characterization results.

Unless otherwise stated, limit values apply for the conditions specified in [Table 16: “Environmental Ratings”](#) and [Table 18: “Recommended Operating Conditions and DC Characteristics”](#). Typical values apply for the following conditions:

- VBAT = 3.6V
- Ambient temperature +25°C

Figure 15. Port Locations for WLAN Testing

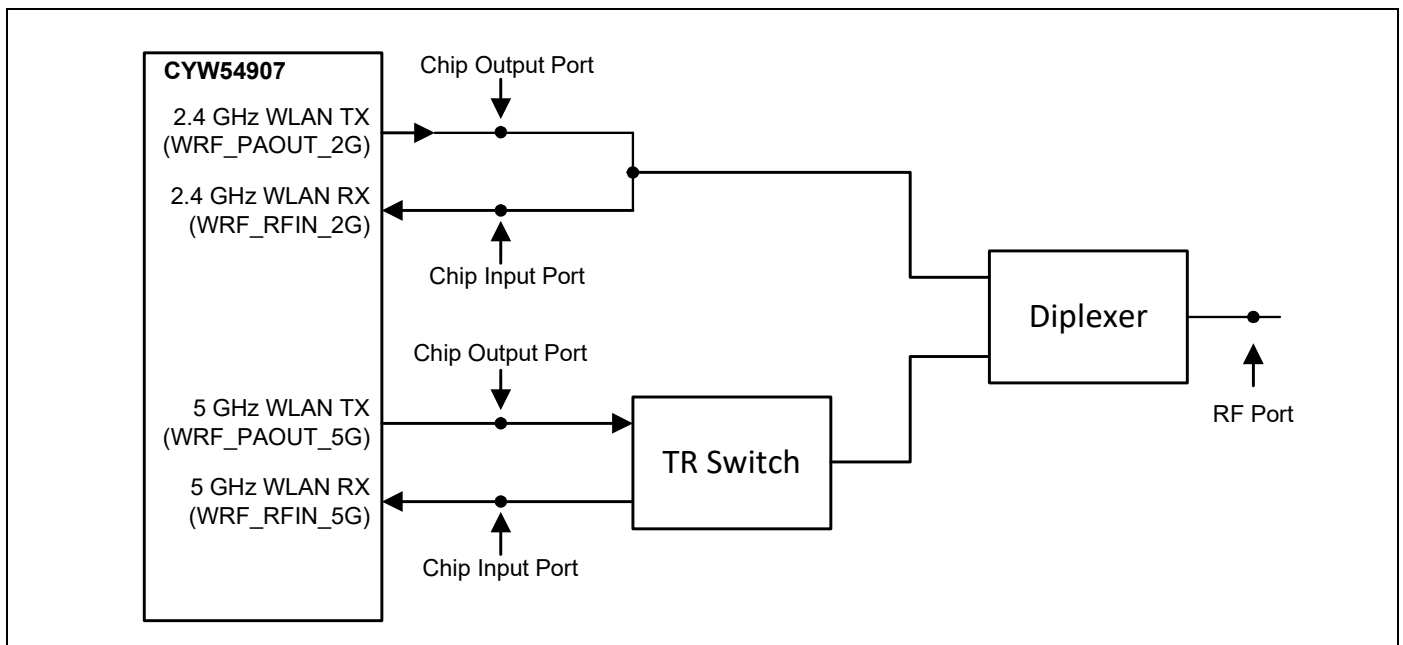

14.2 2.4 GHz Band General RF Specifications

Table 22. 2.4 GHz Band General RF Specifications

Item	Condition	Minimum	Typical	Maximum	Unit
TX/RX switch time	Including TX ramp down	–	–	5	µs
RX/TX switch time	Including TX ramp up	–	–	2	µs
Power-up and power-down ramp time	DSSS/CCK modulations	–	–	< 2	µs

14.3 WLAN 2.4 GHz Receiver Performance Specifications

Note: The specifications shown in [Table 23](#) apply at the chip ports, unless otherwise defined.

Table 23. WLAN 2.4 GHz Receiver Performance Specifications

Parameter	Condition/Notes	Minimum	Typical	Maximum	Unit
Frequency range	–	2400	–	2500	MHz
RX sensitivity IEEE 802.11b (8% PER for 1024 octet PSDU)	1 Mbps DSSS	–	–98.9	–	dBm
	2 Mbps DSSS	–	–96.0	–	dBm
	5.5 Mbps DSSS	–	–93.9	–	dBm
	11 Mbps DSSS	–	–90.4	–	dBm
RX sensitivity IEEE 802.11g (10% PER for 1024 octet PSDU)	6 Mbps OFDM	–	–95.0	–	dBm
	9 Mbps OFDM	–	–93.8	–	dBm
	12 Mbps OFDM	–	–92.7	–	dBm
	18 Mbps OFDM	–	–90.3	–	dBm
	24 Mbps OFDM	–	–87.1	–	dBm
	36 Mbps OFDM	–	–83.6	–	dBm
	48 Mbps OFDM	–	–79.3	–	dBm
	54 Mbps OFDM	–	–78.0	–	dBm
RX sensitivity IEEE 802.11n (10% PER for 4096 octet PSDU) ^a Defined for default parameters: 800 ns GI and non-STBC.	20 MHz channel spacing for all MCS rates				
	MCS0	–	–94.6	–	dBm
	MCS1	–	–92.1	–	dBm
	MCS2	–	–89.8	–	dBm
	MCS3	–	–86.6	–	dBm
	MCS4	–	–83.0	–	dBm
	MCS5	–	–78.3	–	dBm
	MCS6	–	–76.6	–	dBm
	MCS7	–	–75.0	–	dBm
Input in-band IP3	Maximum LNA gain	–	–8	–	dBm
	Minimum LNA gain	–	+9	–	dBm
Maximum receive level @ 2.4 GHz	@ 1, 2 Mbps (8% PER, 1024 octets)	–3.5	–	–	dBm
	@ 5.5, 11 Mbps (8% PER, 1024 octets)	–9.5	–	–	dBm
	@ 6, 9, 12 Mbps (10% PER, 1024 octets)	–9.5	–	–	dBm
	@ MCS0–2 rates (10% PER, 4095 octets)	–9.5	–	–	dBm
	@ 18, 24, 36, 48, 54 Mbps (10% PER, 1024 octets)	–14.5	–	–	dBm
	@ MCS3–7 rates (10% PER, 4095 octets)	–14.5	–	–	dBm
Adjacent channel rejection-DSSS (Difference between interfering and desired signal at 8% PER for 1024 octet PSDU with desired signal level as specified in Condition/Notes.)	Desired and interfering signal 30 MHz apart				
	1 Mbps DSSS	–74 dBm	35	–	dB
	2 Mbps DSSS	–74 dBm	35	–	dB
	Desired and interfering signal 25 MHz apart				
	5.5 Mbps DSSS	–70 dBm	35	–	dB
	11 Mbps DSSS	–70 dBm	35	–	dB

Table 23. WLAN 2.4 GHz Receiver Performance Specifications (Cont.)

Parameter	Condition/Notes		Minimum	Typical	Maximum	Unit
Adjacent channel rejection-OFDM (Difference between interfering and desired signal (25 MHz apart) at 10% PER for 1024 octet PSDU with desired signal level as specified in Condition/Notes.)	6 Mbps OFDM	-79 dBm	16	-	-	dB
	9 Mbps OFDM	-78 dBm	15	-	-	dB
	12 Mbps OFDM	-76 dBm	13	-	-	dB
	18 Mbps OFDM	-74 dBm	11	-	-	dB
	24 Mbps OFDM	-71 dBm	8	-	-	dB
	36 Mbps OFDM	-67 dBm	4	-	-	dB
	48 Mbps OFDM	-63 dBm	0	-	-	dB
	54 Mbps OFDM	-62 dBm	-1	-	-	dB
Adjacent channel rejection MCS0-7 (Difference between interfering and desired signal (25 MHz apart) at 10% PER for 4096 octet PSDU with desired signal level as specified in Condition/Notes.)	MCS0	-79 dBm	16	-	-	dB
	MCS1	-76 dBm	13	-	-	dB
	MCS2	-74 dBm	11	-	-	dB
	MCS3	-71 dBm	8	-	-	dB
	MCS4	-67 dBm	4	-	-	dB
	MCS5	-63 dBm	0	-	-	dB
	MCS6	-62 dBm	-1	-	-	dB
	MCS7	-61 dBm	-2	-	-	dB
Maximum receiver gain	-	-	-	66	-	dB
Gain control step	-	-	-	3	-	dB
RSSI accuracy ^b	Range -95 ^c dBm to -30 dBm		-5	-	5	dB
	Range above -30 dBm		-8	-	8	dB
Return loss	Z ₀ = 50Ω, across the dynamic range		10	11.5	13	dB
Receiver cascaded noise figure	At maximum gain		-	4	-	dB

a. Sensitivity degradations for alternate settings in MCS modes. MM: 0.5 dB drop, and SGI: 2 dB drop.

b. The minimum and maximum values shown have a 95% confidence level.

c. -95 dBm with calibration at time of manufacture, -92 dBm without calibration.

14.4 WLAN 2.4 GHz Transmitter Performance Specifications

Note: Unless otherwise noted, the values shown in Table 24 apply at the chip ports.

Table 24. WLAN 2.4 GHz Transmitter Performance Specifications

Parameter	Condition/Notes		Minimum	Typical	Maximum	Unit
Frequency range	–		2400	–	2500	MHz
RF port TX power EVM ^a (highest power setting, 25°C, and VBAT = 3.6)	DSS/CCK	–9 dB	–	20.5	–	dBm
	OFDM, BPSK	–8 dB	–	20	–	dBm
	OFDM, QPSK	–13 dB	–	20	–	dBm
	OFDM, 16-QAM	–19 dB	–	19	–	dBm
	OFDM, 64-QAM (R = 3/4)	–25 dB	–	19	–	dBm
	OFDM, 64-QAM (MCS7, HT20)	–27 dB	–	18.5	–	dBm
OFDM EVM ^b (25°C, VBAT = 3.6V)	OFDM, BPSK	5 dBm	–29	–31	–	dB
	OFDM, 64-QAM	5 dBm	–31	–33	–	dB
	MCS7	5 dBm	–33	–35	–	dB
Phase noise	37.4 MHz crystal, integrated from 10 kHz to 10 MHz		–	0.45	–	Degrees
TX power control dynamic range	–		10	–	–	dB
Closed-loop TX power variation at highest power level setting	Across full temperature and voltage range. Applies to 10 dBm to 20 dBm output power range.		–	–	±1.5	dB
Carrier suppression	–		15	–	–	dBc
Gain control step	–		–	0.25	–	dB
Return loss at Chip port TX	Z _o = 50Ω		–	6	–	dB

a. This specification row indicates the linear power specification as measured from the chip output port. The requirement is in dBm (TX power). The ratio (dB) in the Conditions/Notes column is the EVM.

b. This specification row indicates the EVM floor. The requirement is in dB (EVM). The power in the Conditions/Notes column is the TX power specification in dBm.

14.5 WLAN 5 GHz Receiver Performance Specifications

Note: Unless otherwise noted, the values shown in [Table 25](#) apply at the chip ports.

Table 25. WLAN 5 GHz Receiver Performance Specifications

Parameter	Condition/Notes	Minimum	Typical	Maximum	Unit
Frequency range	–	4900	–	5845	MHz
RX sensitivity IEEE 802.11a (10% PER for 1000 octet PSDU)	6 Mbps OFDM	–	–93.6	–	dBm
	9 Mbps OFDM	–	–92.4	–	dBm
	12 Mbps OFDM	–	–91.3	–	dBm
	18 Mbps OFDM	–	–88.9	–	dBm
	24 Mbps OFDM	–	–85.7	–	dBm
	36 Mbps OFDM	–	–82.3	–	dBm
	48 Mbps OFDM	–	–77.9	–	dBm
	54 Mbps OFDM	–	–76.6	–	dBm
RX sensitivity IEEE 802.11n (10% PER for 4096 octet PSDU) Defined for default parameters: 800 ns GI and non-STBC.	20 MHz channel spacing for all MCS rates				
	MCS0	–	–93.2	–	dBm
	MCS1	–	–90.7	–	dBm
	MCS2	–	–88.4	–	dBm
	MCS3	–	–85.2	–	dBm
	MCS4	–	–81.6	–	dBm
	MCS5	–	–76.9	–	dBm
	MCS6	–	–75.2	–	dBm
	MCS7	–	–73.6	–	dBm
RX sensitivity IEEE 802.11n (10% PER for 4096 octet PSDU) Defined for default parameters: 800 ns GI and non-STBC.	40 MHz channel spacing for all MCS rates				
	MCS0	–	–90.3	–	dBm
	MCS1	–	–87.5	–	dBm
	MCS2	–	–84.9	–	dBm
	MCS3	–	–81.8	–	dBm
	MCS4	–	–78.3	–	dBm
	MCS5	–	–73.9	–	dBm
	MCS6	–	–72.7	–	dBm
	MCS7	–	–71.2	–	dBm
RX sensitivity IEEE 802.11ac (10% PER for 4096 octet PSDU) Defined for default parameters: 800 ns GI and non-STBC.	20 MHz channel spacing for all MCS rates				
	MCS0 NSS1	–	–93.2	–	dBm
	MCS1 NSS1	–	–90.7	–	dBm
	MCS2 NSS1	–	–88.4	–	dBm
	MCS3 NSS1	–	–85.2	–	dBm
	MCS4 NSS1	–	–81.6	–	dBm
	MCS5 NSS1	–	–76.9	–	dBm
	MCS6 NSS1	–	–75.2	–	dBm
	MCS7 NSS1	–	–73.6	–	dBm
MCS8 NSS1	–	–69.6	–	dBm	

Table 25. WLAN 5 GHz Receiver Performance Specifications (Cont.)

Parameter	Condition/Notes		Minimum	Typical	Maximum	Unit
RX sensitivity IEEE 802.11ac (10% PER for 4096 octet PSDU) Defined for default parameters: 800 ns GI and non-STBC.	40 MHz channel spacing for all MCS rates					
	MCS0 NSS1		–	–90.3	–	dBm
	MCS1 NSS1		–	–87.5	–	dBm
	MCS2 NSS1		–	–84.9	–	dBm
	MCS3 NSS1		–	–81.8	–	dBm
	MCS4 NSS1		–	–78.3	–	dBm
	MCS5 NSS1		–	–73.9	–	dBm
	MCS6 NSS1		–	–72.7	–	dBm
	MCS7 NSS1		–	–71.2	–	dBm
	MCS8 NSS1		–	–66.6	–	dBm
	MCS9 NSS1		–	–65.8	–	dBm
RX sensitivity IEEE 802.11ac (10% PER for 4096 octet PSDU) Defined for default parameters: 800 ns GI and non-STBC.	80 MHz channel spacing for all MCS rates					
	MCS0 NSS1		–	–87.2	–	dBm
	MCS1 NSS1		–	–84.7	–	dBm
	MCS2 NSS1		–	–82.4	–	dBm
	MCS3 NSS1		–	–79.2	–	dBm
	MCS4 NSS1		–	–75.6	–	dBm
	MCS5 NSS1		–	–70.9	–	dBm
	MCS6 NSS1		–	–69.2	–	dBm
	MCS7 NSS1		–	–67.6	–	dBm
	MCS8 NSS1		–	–63.6	–	dBm
	MCS9 NSS1		–	–62.5	–	dBm
RX sensitivity IEEE 802.11ac 20/40/80 MHz channel spacing with LDPC (10% PER for 4096 octet PSDU) at chip input. Defined for default parameters: 800 ns GI, LDPC coding and non-STBC.	MCS7 NSS1	20 MHz	–	–75.5	–	dBm
	MCS8 NSS1	20 MHz	–	–71.5	–	dBm
	MCS7 NSS1	40 MHz	–	–73.0	–	dBm
	MCS8 NSS1	40 MHz	–	–69.0	–	dBm
	MCS9 NSS1	40 MHz	–	–67.1	–	dBm
	MCS7 NSS1	80 MHz	–	–70.0	–	dBm
	MCS8 NSS1	80 MHz	–	–66.0	–	dBm
	MCS9 NSS1	80 MHz	–	–63.9	–	dBm
Input in-band IP3	Maximum LNA gain		–	–12	–	dBm
	Minimum LNA gain		–	+4	–	dBm
Maximum receive level @ 5 GHz	@ 6, 9, 12 Mbps (10% PER, 1024 octets)		–9.5	–	–	dBm
	@ MCS0–2 rates (10% PER, 4095 octets)		–9.5	–	–	dBm
	@ 18, 24, 36, 48, 54 Mbps (10% PER, 1024 octets)		–14.5	–	–	dBm
	@ MCS3–7 rates (10% PER, 4095 octets)		–14.5	–	–	dBm

Table 25. WLAN 5 GHz Receiver Performance Specifications (Cont.)

Parameter	Condition/Notes		Minimum	Typical	Maximum	Unit
Adjacent channel rejection (Difference between interfering and desired signal (20 MHz apart) at 10% PER for 1000 octet PSDU with desired signal level as specified in Condition/Notes)	6 Mbps OFDM	-79 dBm	16	-	-	dB
	9 Mbps OFDM	-78 dBm	15	-	-	dB
	12 Mbps OFDM	-76 dBm	13	-	-	dB
	18 Mbps OFDM	-74 dBm	11	-	-	dB
	24 Mbps OFDM	-71 dBm	8	-	-	dB
	36 Mbps OFDM	-67 dBm	4	-	-	dB
	48 Mbps OFDM	-63 dBm	0	-	-	dB
	54 Mbps OFDM	-62 dBm	-1	-	-	dB
	65 Mbps OFDM	-61 dBm	-2	-	-	dB
Alternate adjacent channel rejection (Difference between interfering and desired signal (40 MHz apart) at 10% PER for 1000 ^a octet PSDU with desired signal level as specified in Condition/Notes)	6 Mbps OFDM	-78.5 dBm	32	-	-	dB
	9 Mbps OFDM	-77.5 dBm	31	-	-	dB
	12 Mbps OFDM	-75.5 dBm	29	-	-	dB
	18 Mbps OFDM	-73.5 dBm	27	-	-	dB
	24 Mbps OFDM	-70.5 dBm	24	-	-	dB
	36 Mbps OFDM	-66.5 dBm	20	-	-	dB
	48 Mbps OFDM	-62.5 dBm	16	-	-	dB
	65 Mbps OFDM	-60.5 dBm	14	-	-	dB
Maximum receiver gain	-		-	66	-	dB
Gain control step	-		-	3	-	dB
RSSI accuracy ^b	Range -92 dBm to -30 dBm		-5	-	5	dB
	Range above -30 dBm		-8	-	8	dB
Return loss	Z _o = 50Ω, across the dynamic range		10	-	13	dB
Receiver cascaded noise figure	At maximum gain		-	5	-	dB

a. For 65 Mbps, the size is 4096.

b. The minimum and maximum values shown have a 95% confidence level.

14.6 WLAN 5 GHz Transmitter Performance Specifications

Note: Unless otherwise noted, the values shown in Table 26 apply at the chip ports.

Table 26. WLAN 5 GHz Transmitter Performance Specifications

Parameter	Condition/Notes		Minimum	Typical	Maximum	Unit
Frequency range	–		4900	–	5845	MHz
RF port TX power EVM ^a (highest power setting, 25°C, and VBAT = 3.6)	OFDM, QPSK	–13 dB	–	20	–	dBm
	OFDM, 16-QAM	–19 dB	–	18.5	–	dBm
	OFDM, 64-QAM (R = 3/4)	–25 dB	–	17	–	dBm
	OFDM, 64-QAM (MCS7, HT20)	–27 dB	–	16.5	–	dBm
RF port TX power EVM ^a (highest power setting, 25°C, and VBAT = 3.6), BW40	MCS8	–30 dB		14.5		
	MCS9	–32 dB		13.5		
RF port TX power EVM ^a (highest power setting, 25°C, and VBAT = 3.6), BW80	MCS8	–30 dB		14		
	MCS9	–32 dB		13		
OFDM EVM ^b (25°C, VBAT = 3.6V)	OFDM, BPSK	0 dBm	–	–30	–	dB
	OFDM, 64-QAM	0 dBm	–	–33	–	dB
	MCS7	0 dBm	–	–34	–	dB
OFDM EVM ^b (25°C, VBAT = 3.6V), BW40	MCS8	0 dBm		–34		
	MCS9	0 dBm		–34		
OFDM EVM ^b (25°C, VBAT = 3.6V), BW80	MCS8	0 dBm		–34		
	MCS9	0 dBm		–34		
Phase noise	37.4 MHz Crystal, Integrated from 10 kHz to 10 MHz		–	0.5	–	Degrees
TX power control dynamic range	–		10	–	–	dB
Closed loop TX power variation at highest power level setting	Across full-temperature and voltage range. Applies across 10 to 20 dBm output power range.		–	–	±2.0	dB
Carrier suppression	–		15	–	–	dBc
Gain control step	–		–	0.25	–	dB
Return loss	Z _o = 50Ω		–	6	–	dB

a. This specification row indicates the linear power specification as measured from the chip output port. The requirement is in dBm (TX power). The ratio (dB) in the Conditions/Notes column is the EVM.

b. This specification row indicates the EVM floor. The requirement is in dB (EVM). The power in the Conditions/Notes column is the TX power specification in dBm.

14.7 General Spurious Emissions Specifications

This section provides the TX and RX spurious emissions specifications for the WLAN 2.4 GHz and 5 GHz bands. The recommended spectrum analyzer settings for the spurious emissions specifications are provided in [Table 27](#).

Table 27. Recommended Spectrum Analyzer Settings

Parameter	Setting
Resolution bandwidth (RBW)	1 MHz
Video bandwidth (VBW)	1 MHz
Sweep	Auto
Span	100 MHz
Detector	Maximum peak
Trace	Maximum hold
Modulation	OFDM

14.7.1 Transmitter Spurious Emissions Specifications

2.4 GHz Band Spurious Emissions

20-MHz Channel Spacing

Table 28. 2.4 GHz Band, 20-MHz Channel Spacing TX Spurious Emissions Specifications

2G- 20 MHz BW		Spurious Emission Level (dBm)
Emission Frequency Range (MHz)	Channel Power (dBm)	CH2442
1000-2000	21	-50
2000-4000	21	-40
2500-3000	21	-40
3000-4000	21	-39
4000-5000	21	-24
5000-6000	21	-48
6000-7000	21	-49
7000-8000	21	-13
8000-10000	21	-43
10000-12000	21	-52
12000-15000	21	-50
15000-20000	21	-49

5 GHz Band Spurious Emissions

20-MHz Channel Spacing

Table 29. 5 GHz Band, 20-MHz Channel Spacing TX Spurious Emissions Specifications

5G- 20 MHz BW		Spurious Emission Level (dBm)		
Emission Frequency Range (MHz)	Channel Power (dBm)	CH5180	CH5500	CH5825
1000-2000	19	-50	-51	-50
2000-4000	19	-48	-48	-49
3000-4000	19	-42	-43	-40
4000-5000	19	-42	-46	-48
5000-6000	19	-41	-40	-40
6000-7000	19	-48	-49	-47
7000-8000	19	-50	-49	-49
8000-10000	19	-53	-52	-53
10000-12000	19	-10	-13	-17
12000-15000	19	-51	-51	-51
15000-20000	19	-19	-19	-20

40-MHz Channel Spacing

Table 30. 5 GHz Band, 40-MHz Channel Spacing TX Spurious Emissions Specifications

5G- 40 MHz BW		Spurious Emission Level (dBm)		
Emission Frequency Range (MHz)	Channel Power (dBm)	CH5190m	CH5510m	CH5795m
1000-2000	19	-50	-52	-52
2000-4000	19	-49	-50	-49
3000-4000	19	-43	-42	-39
4000-5000	19	-42	-44	-48
5000-6000	19	-40	-40	-38
6000-7000	19	-48	-48	-48
7000-8000	19	-49	-48	-48
8000-10000	19	-52	-53	-53
10000-12000	19	-12	-15	-19
12000-15000	19	-51	-51	-51
15000-20000	19	-24	-22	-24

80-MHz Channel Spacing

Table 31. 5 GHz Band, 40-MHz Channel Spacing TX Spurious Emissions Specifications

5G- 80 MHz BW		Spurious Emission Level (dBm)		
Emission Frequency Range (MHz)	Channel Power (dBm)	CH5210q	CH5530q	CH5775q
1000-2000	19	-52	-51	-52
2000-3000	19	-49	-49	-49
3000-4000	19	-42	-43	-39
4000-5000	19	-45	-46	-48
5000-6000	19	-40	-41	-35
6000-7000	19	-47	-50	-48
7000-8000	19	-49	-50	-49
8000-10000	19	-53	-53	-53
10000-12000	19	-15	-18	-21
12000-15000	19	-50	-51	-51
15000-20000	19	-25	-26	-26

14.7.2 Receiver Spurious Emissions Specifications

Table 32. 2G and 5G General Receiver Spurious Emissions

Band	Frequency Range	Typical	Maximum	Unit
2G	2.4 GHz < f < 2.5 GHz	-75.5	-74.1	dBm
	3.6 GHz < f < 3.8 GHz	-52.8	-50.9	dBm
5G	5150 MHz < f < 5850 MHz	-57.7	-56.1	dBm
	3.45 GHz < f < 3.9 GHz	-48.6	-47.6	dBm

15. Internal Regulator Electrical Specifications

15.1 Core Buck Switching Regulator

Note: Values in this data sheet are design goals and are subject to change based on device characterization results.

Note: Functional operation is not guaranteed outside of the specification limits provided in this section.

Table 33. Core Buck Switching Regulator (CLOCK) Specifications

Specification	Notes	Min.	Typ.	Max.	Unit
Input supply voltage (DC)	DC voltage range inclusive of disturbances.	3.0	3.6	4.8 ^a	V
PWM mode switching frequency	CCM, load > 100 mA VBAT = 3.6V.	–	4	–	MHz
PWM output current	–	–	–	550	mA
Output current limit	–	–	1400	–	mA
Output voltage range	Programmable, 30 mV steps. Default = 1.35V.	1.2	1.35	1.5	V
PWM output voltage DC accuracy	Includes load and line regulation. Forced PWM mode.	–4	–	4	%
PWM ripple voltage, static	Measure with 20 MHz bandwidth limit. Static load. Max. ripple based on VBAT = 3.6V, Vout = 1.35V, Fsw = 4 MHz, 2.2 μH inductor with min. effective L > 1.05 μH, cap. + board total – ESR < 20 mΩ, Cout > 1.9 μF, ESL < 200 pH	–	7	20	mVpp
PWM mode peak efficiency	Peak efficiency at 200 mA load.	78	86	–	%
PFM mode efficiency	10 mA load current.	70	81	–	%
Start-up time from power down	VIO already ON and steady. Time from REG_ON rising edge to CLDO reaching 1.2V.	–	400	500	μs
External inductor	0806 size, 2.2 μH, DCR = 0.11Ω, ACR = 1.18Ω @ 4 MHz.	–	2.2	–	μH
External output capacitor	Ceramic, X5R, 0402, ESR < 30 mΩ at 4 MHz, 4.7 μF ±20%, 6.3V.	2.0 ^b	4.7	10 ^c	μF
External input capacitor	For SR_VDDBAT5V pin, ceramic, X5R, 0603, ESR < 30 mΩ at 4 MHz, ±4.7 μF ±20%, 6.3V.	0.67 ^b	4.7	–	μF
Input supply voltage ramp-up time	0 to 4.3V.	40	–	–	μs

a. The maximum continuous voltage is 4.8V. Voltages up to 6.0V for up to 10 seconds, cumulative duration, over the lifetime of the device are allowed. Voltages as high as 5.0V for up to 250 seconds, cumulative duration, over the lifetime of the device are allowed.

b. Minimum capacitor value refers to the residual capacitor value after taking into account the part-to-part tolerance, DC-bias, temperature, and aging.

c. Total capacitance includes those connected at the far end of the active load.

15.2 3.3V LDO (LDO3P3)

Table 34. LDO3P3 Specifications

Specification	Notes	Min.	Typ.	Max.	Units
Input supply voltage, V_{in}	Min. = $V_o + 0.2V = 3.5V$ dropout voltage requirement must be met under maximum load for performance specifications.	3.0	3.6	4.8 ^a	V
Output current	–	0.001	–	450	mA
Nominal output voltage, V_o	Default = 3.3V.	–	3.3	–	V
Dropout voltage	At max. load.	–	–	200	mV
Output voltage DC accuracy	Includes line/load regulation.	–5	–	+5	%
Quiescent current	No load.	–	–	85	μA
Line regulation	V_{in} from ($V_o + 0.2V$) to 4.8V, max. load.	–	–	3.5	mV/V
Load regulation	Load from 1 mA to 450 mA.	–	–	0.3	mV/mA
PSRR	$V_{in} \geq V_o + 0.2V$, $V_o = 3.3V$, $C_o = 4.7 \mu F$, Max load, 100 Hz to 100 kHz.	20	–	–	dB
LDO turn-on time	Chip already powered up.	–	160	250	μs
External output capacitor, C_o	Ceramic, X5R, 0402, (ESR: 5 m Ω –240 m Ω), $\pm 10\%$, 10V.	1.0 ^b	4.7	10	μF
External input capacitor	For LDO_VDDBAT5V pin (shared with band gap) ceramic, X5R, 0402, (ESR: 30m Ω –200 m Ω), $\pm 10\%$, 10V. Not needed if sharing 4.7 μF VBAT capacitor with SR_VDDBAT5V.	–	4.7	–	μF

a. The maximum continuous voltage is 4.8V. Voltages up to 6.0V for up to 10 seconds, cumulative duration, over the lifetime of the device are allowed. Voltages as high as 5.0V for up to 250 seconds, cumulative duration, over the lifetime of the device are allowed.

b. Minimum capacitor value refers to the residual capacitor value after taking into account the part-to-part tolerance, DC-bias, temperature, and aging.

15.3 CLDO
Table 35. CLDO Specifications

Specification	Notes	Min.	Typ.	Max.	Units
Input supply voltage, V_{in}	Min. = $1.2 + 0.15V = 1.35V$ dropout voltage requirement must be met under maximum load.	1.3	1.35	1.5	V
Output current	–	0.2	–	350	mA
Output voltage, V_o	Programmable in 10 mV steps. Default = 1.2V.	0.95	1.2	1.26	V
Dropout voltage	At max. load.	–	–	150	mV
Output voltage DC accuracy	Includes line/load regulation.	–4	–	+4	%
Quiescent current	No load.	–	26	–	μA
	200 mA load.	–	2.48	–	mA
Line regulation	V_{in} from ($V_o + 0.15V$) to 1.5V, maximum load.	–	–	5	mV/V
Load regulation	Load from 1 mA to 300 mA.	–	0.02	0.05	mV/mA
Leakage current	Power down.	–	10	40	μA
	Bypass mode.	–	2	6	μA
PSRR	@1 kHz, $V_{in} \geq 1.35V$, $C_o = 4.7 \mu F$.	20	–	–	dB
Start-up time of PMU	VIO up and steady. Time from the REG_ON rising edge to the CLDO reaching 1.2V.	–	–	700	μs
LDO turn-on time	LDO turn-on time when the rest of the chip is up.	–	140	180	μs
External output capacitor, C_o	Total ESR: 5 m Ω –240 m Ω .	3.76 ^a	4.7	–	μF
External input capacitor	Only use an external input capacitor at the LDO_VDD1P5 pin if it is not supplied from the CBUCK output.	–	1	2.2	μF

a. Minimum capacitor value refers to the residual capacitor value after taking into account the part-to-part tolerance, DC-bias, temperature, and aging.

15.4 LNLDO

Table 36. LNLDO Specifications

Specification	Notes	Min.	Typ.	Max.	Units
Input supply voltage, V_{in}	Min. $V_{IN} = V_O + 0.15V = 1.35V$ (where $V_O = 1.2V$) dropout voltage requirement must be met under maximum load.	1.3	1.35	1.5	V
Output current	–	0.1	–	150	mA
Output voltage, V_O	Programmable in 25 mV steps. Default = 1.2V.	1.1	1.2	1.275	V
Dropout voltage	At maximum load.	–	–	150	mV
Output voltage DC accuracy	Includes line/load regulation.	–4	–	+4	%
Quiescent current	No load.	–	44	–	μA
	Max. load.	–	970	990	μA
Line regulation	V_{in} from ($V_O + 0.1V$) to 1.5V, 150 mA load.	–	–	5	mV/V
Load regulation	Load from 1 mA to 150 mA.	–	0.02	0.05	mV/mA
Leakage current	Power-down.	–	–	10	μA
Output noise	@30 kHz, 60–150 mA load $C_O = 2.2 \mu F$.	–	–	60	nV/rt Hz
	@100 kHz, 60–150 mA load $C_O = 2.2 \mu F$.	–	–	35	nV/rt Hz
PSRR	@ 1kHz, Input > 1.35V, $C_O = 2.2 \mu F$, $V_O = 1.2V$.	20	–	–	dB
LDO turn-on time	LDO turn-on time when the rest of the chip is up.	–	140	180	μs
External output capacitor, C_O	Total ESR (trace/capacitor): 5 m Ω –240 m Ω .	0.5 ^a	2.2	4.7	μF
External input capacitor	Only use an external input capacitor at the LDO_VDD1P5 pin if it is not supplied from the CBUCK output. Total ESR (trace/capacitor): 30 m Ω –200 m Ω .	–	1	2.2	μF

a. Minimum capacitor value refers to the residual capacitor value after taking into account the part-to-part tolerance, DC-bias, temperature, and aging.

15.5 BBPLL LDO

Table 37. BBPLL LDO Specifications

Parameter	Conditions and Comments	Min.	Typ.	Max.	Units
Input supply voltage, V_{in}	Min. $V_{in} = V_o + 0.15V = 1.35V$ (for $V_o = 1.2V$). The dropout voltage requirement must be met under maximum load.	1.3	1.35	1.5	V
Output voltage, V_o	Programmable in 25 mV steps. Default = 1.2V.	1.1	1.2	1.275	V
Dropout voltage	At max. load	–	–	150	mV
Output voltage DC accuracy	Includes line/load regulation.	–4	–	+4	%
Output current	Peak load = 80 mA, average = 35 mA	0.1	–	55	mA
Quiescent current	No load	–	10	12	μA
	55 mA load	–	550	570	μA
Line regulation	V_{in} from ($V_o + 0.15V$) to 1.5V; 200 mA load	–	–	5	mV/V
Load regulation	load from 1mA to 200 mA; $V_{in} \geq (V_o + 0.15V)$	–	0.025	0.045	mV/mA
Leakage current	Powered down. Junction temperature is 85°C.	–	5	20	μA
	Bypass mode	–	0.2	1.5	μA
PSRR	@1 kHz, $V_{in} \geq V_o + 0.15V$, $C_o = 4.7 \mu F$	20	–	–	dB
Start-up time of PMU	VIO up and steady. Time from REG_ON rising edge to CLDO reaching 99% of V_o .	–	530	700	us
LDO turn-on time	The LDO turn-on time when the rest of the chip is up.	–	140	180	us
Inrush current	$V_{in} = V_o + 0.15V$ to 1.5V, $C_o = 0.47 \mu F$, no load	–	60	70	mA
External output capacitor, C_o	Ceramic, X5R, size 0201, max. 6.3V, 20% tolerance	0.27	0.47	–	μF
External input capacitor	Only use an external input capacitor at the LDO_VDD1P5 pin if it is not supplied from the CBUCK output.	–	1	–	μF

16. System Power Consumption

Note: Values in this data sheet are design goals and are subject to change based on the results of device characterization.

Note: Unless otherwise stated, these values apply for the conditions specified in Table 18: “Recommended Operating Conditions and DC Characteristics”.

16.1 WLAN Current Consumption

The tables in this subsection show the typical, total current used by the CYW54907. Current values may be measured with the APPS core powered off. The first column of the table, the mode description, will state the power condition of the APPS core.

16.1.1 2.4 GHz Mode

Table 38. 2.4 GHz Mode WLAN Current Consumption

Mode	V _{BAT} = 3.6V ^a (μA)	VDDIO = VDDIO_HIB = 3.3V ^{a, b, c} (μA)
Sleep Modes		
Radio off ^d	3	3
Sleep ^{e, f}	6	160
IEEE Power Save, DTIM=1, single RX, APPS powered down ^g	2180	160
IEEE Power Save, DTIM=3, single RX, APPS powered down ^h	680	160
IEEE Power Save, DTIM=9, single RX, APPS powered down	233	160
Active Modes		
Continuous RX mode MCS7, HT20, 1SS, APPS powered up ^{i, j}	57,200	60
CRS-HT20, APPS powered up ^k	55,200	60
Continuous TX mode 1 Mbps, APPS powered up ^l	325,000	60
Continuous TX mode MCS7, HT20, 1SS, APPS powered up ^m	302,000	60
Ping Modes		
Ping to associated access point ^l	336,000	60
Sleep	6	160

a. Typical silicon.

b. VIO is specified with all pins idle (not switching) and not driving any loads.

c. Excludes VDDIO_USB, VDDIO_RMII, VDDIO_I2S, and VDDIO_SD.

d. REG_ON is low or the device is in hibernation, and all supplies are present.

e. REG_ON is high. APPS domain is powered down. WLAN domain is in low-power state retention mode. Top level is powered up.

f. Inter-beacon current.

g. Beacon Interval = 102.4 ms. Beacon duration = 1 ms @ 1 Mbps. Average current over 3× DTIM intervals.

h. Beacon interval = 307.2 ms. Beacon duration = 1 ms @ 1 Mbps. Average current over 3× DTIM intervals.

i. Duty cycle is 100%. Carrier sense (CS) detect/packet receive.

j. Measured using packet engine test mode.

k. Carrier sense (CCA) when no carrier present.

l. Duty cycle is 100%. TX power at chip output ~17.7 dBm.

m. Duty cycle is 100%. TX power at chip output ~15.2 dBm.

16.1.2 5 GHz Mode

Table 39. 5 GHz Mode WLAN Current Consumption

Mode	V _{BAT} = 3.6V ^a (μA)	VDDIO = VDDIO_HIB = 3.3V ^{a, b, c} (μA)
Sleep Modes		
Radio off ^d	3	3
Sleep ^{e, f}	6	160
IEEE Power Save, DTIM=1, single RX, APPS powered down ^g	1390	160
IEEE Power Save, DTIM=3, single RX, APPS powered down ^h	470	160
IEEE Power Save, DTIM=9, single RX, APPS powered down	160	160
Active Modes		
Continuous RX mode MCS7, HT20, 1SS, APPS powered up ^{i, j}	72,400	60
Continuous RX mode MCS7, HT40, 1SS, APPS powered up ^{i, j}	84,700	60
Continuous RX mode MCS9, VHT80, 1SS, APPS powered up ^{i, j}	112,000	60
CRS-HT20, APPS powered up ^k	70,200	60
CRS-HT40, APPS powered up ^k	79,500	60
Continuous TX mode MCS7, HT20, 1SS, APPS powered up ^l	312,000	60
Continuous TX mode MCS7, HT40, 1SS, APPS powered up ^m	309,000	60
Continuous TX mode MCS9, VHT80, 1SS, APPS powered up ⁿ	334,000	60
Ping Modes		
Ping to associated access point ^l	327,000	60
Sleep	6	160

- a. Typical silicon.
- b. VIO is specified with all pins idle (not switching) and not driving any loads.
- c. Excludes VDDIO_USB, VDDIO_RMII, VDDIO_I2S, and VDDIO_SD.
- d. REG_ON is low or the device is in hibernation, and all supplies are present.
- e. REG_ON is high. APPS domain is powered down. WLAN domain is in low-power state retention mode. Top level is powered up.
- f. Inter-beacon current.
- g. Beacon Interval = 102.4 ms. Beacon duration = 1 ms @ 1 Mbps. Average current over 3× DTIM intervals.
- h. Beacon interval = 307.2 ms. Beacon duration = 1 ms @ 1 Mbps. Average current over 3× DTIM intervals.
- i. Duty cycle is 100%. Carrier sense (CS) detect/packet receive.
- j. Measured using packet engine test mode.
- k. Carrier sense (CCA) when no carrier present.
- l. Duty cycle is 100%. TX power at chip output ~13.9 dBm.
- m. Duty cycle is 100%. TX power at chip output ~12.9 dBm.
- n. Duty cycle is 100%. TX power at chip output ~10.4 dBm

17. Interface Timing and AC Characteristics

17.1 Ethernet MAC (MII/RMII) Interface Timing

17.1.1 MII Receive Packet Timing

Figure 16 and Table 40 provide the MII receive packet timing.

Figure 16. MII Receive Packet Timing

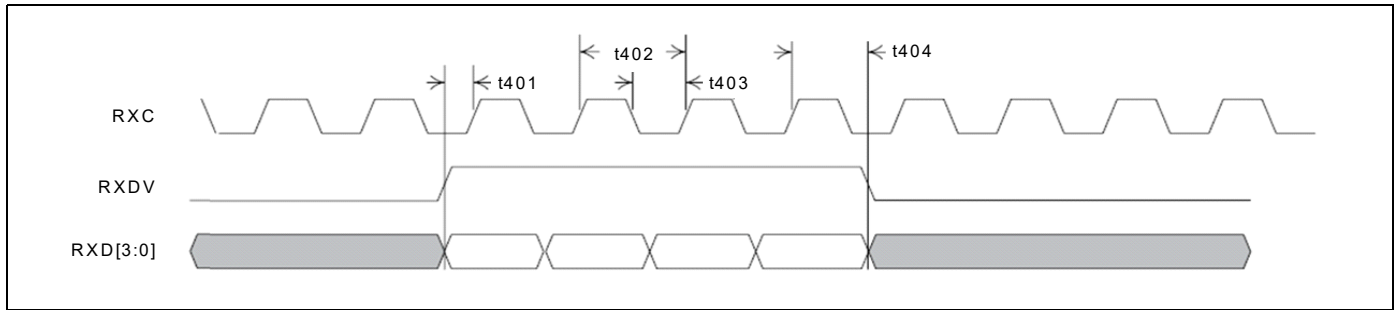

Table 40. MII Receive Packet Timing Parameters

Parameter	Description	Minimum	Typical	Maximum	Units
t401	RXDV and RXD[3:0] to RXC rising setup time	10	–	–	ns
t402	RXC clock period (10BASE-T mode)	–	400	–	ns
	RXC clock period (100BASE-TX mode)	–	40	–	ns
t403	RXC low/high time (10BASE-T mode)	160	–	240	ns
	RXC low/high time (100BASE-TX mode)	16	–	24	ns
t404	RXDV and RXD[3:0] to RXC rising hold time	10	–	–	ns
–	Duty cycle	40	50	60	%

17.1.2 MII Transmit Packet Timing

Figure 17 and Table 41 provide the MII transmit packet timing.

Figure 17. MII Transmit Packet Timing

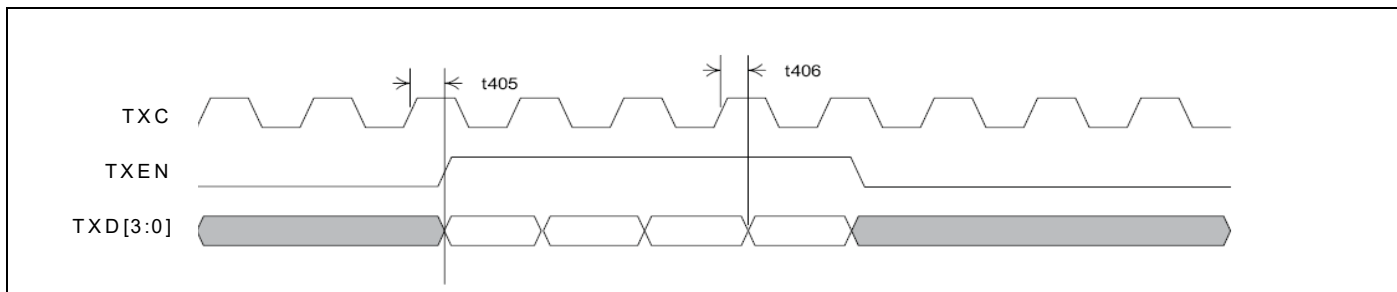

Table 41. MII Transmit Packet Timing Parameters

Parameter	Description	Minimum	Typical	Maximum	Units
t405	TXC high to TXEN and TXD[3:0] valid	0	–	25	ns
t406	TXC high to TXEN and TXD[3:0] invalid (hold)	0	–	–	ns

17.1.3 RMI Receive Packet Timing

Figure 18 and Table 42 provide the RMI receive packet timing.

Figure 18. RMI Receive Packet Timing

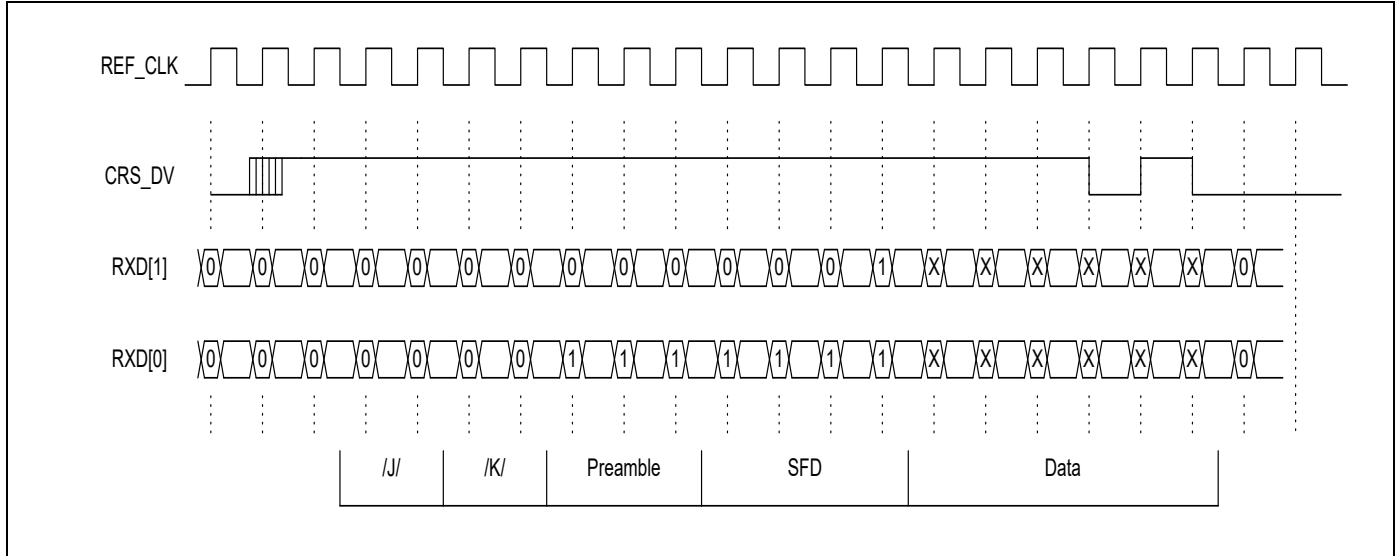

Table 42. RMI Receive Packet Timing

Parameter	Symbol	Minimum	Typical	Maximum	Unit
REF_CLK Cycle Time	–	–	20	–	ns
RXD[1:0], RXER, CRS_DV Output delay from REF_CLK rising	–	2	–	10	ns

Notes:

1. In 10 Mbps mode, there are ten REF_CLK periods per data period.
2. The receiver accounts for differences between the local REF_CLK and the recovered clock through use of sufficient elasticity buffering.

17.1.4 RMIIT Transmit Packet Timing

Figure 19 and Table 43 provide the RMIIT transmit packet timing.

Figure 19. RMIIT Transmit Packet Timing

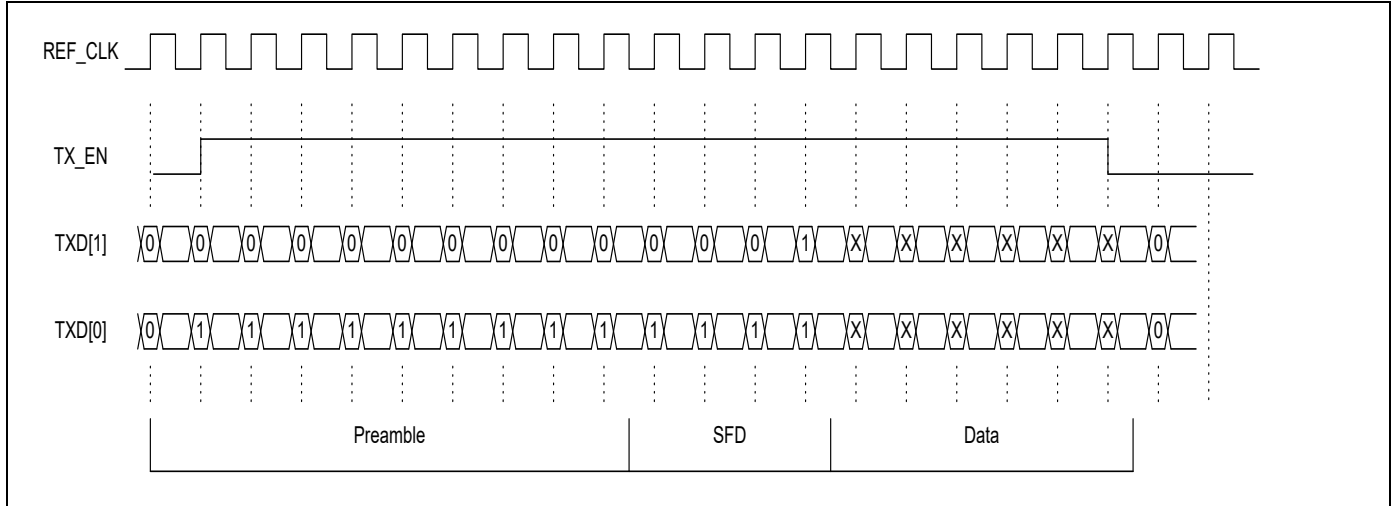

Table 43. RMIIT Transmit Packet Timing Parameters

Parameter	Symbol	Minimum	Typical	Maximum	Unit
REF_CLK Cycle Time	–	–	20	–	ns
TXEN, TXER, TXD[1:0] setup time to REF_CLK rising	TXEN_SETUP	4	–	–	ns
TXEN, TXER, TXD[1:0] hold time from REF_CLK rising	TXEN_HOLD	2	–	–	ns

Notes:

1. TXD[1:0] provides valid data for each REF_CLK period while TX_EN is asserted.
2. In 10 Mbps mode, there are ten REF_CLK periods per data period.

17.2 I²S Master and Slave Mode TX Timing

Figure 20 and Table 44 provide the I²S Master mode transmitter timing.

Figure 20. I²S Master Mode Transmitter Timing

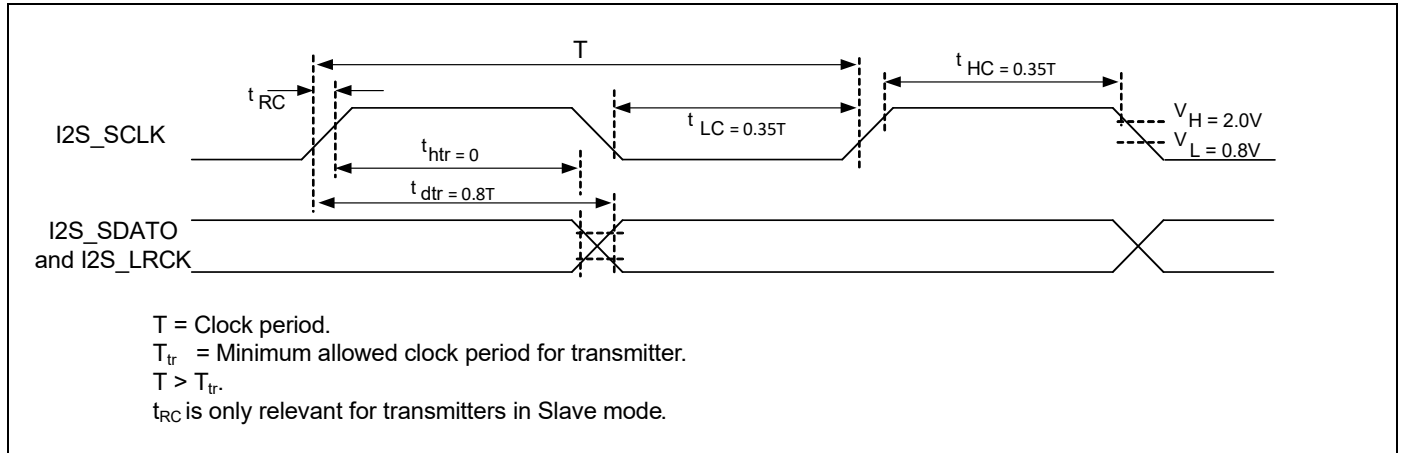

Figure 21 and Table 44 provide the I²S Slave mode receiver timing.

Figure 21. I²S Slave Mode Receiver Timing

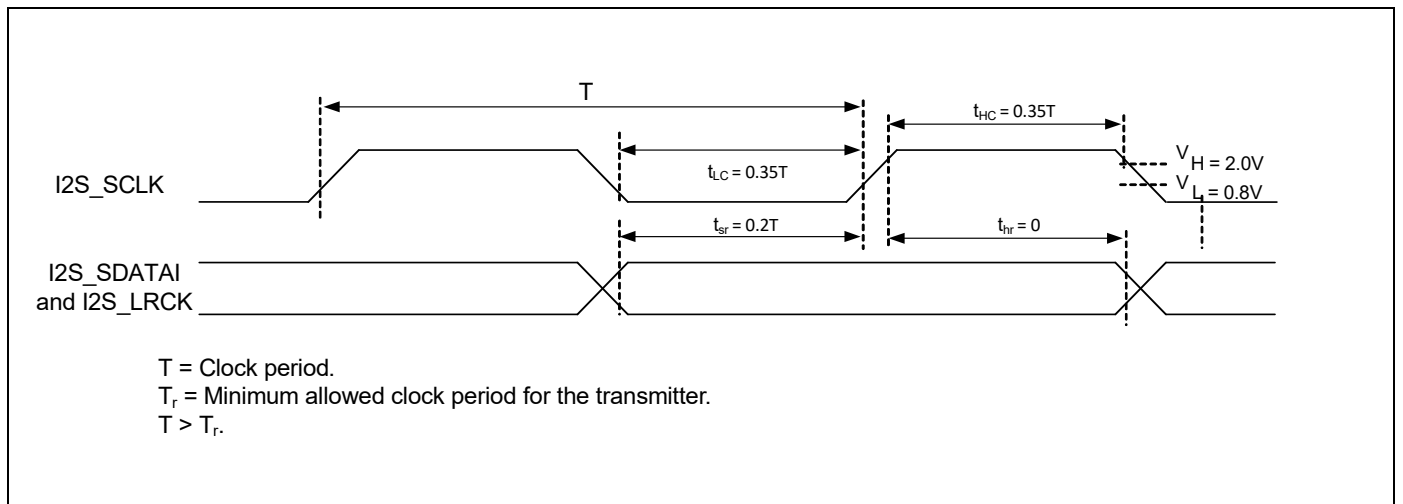

Table 44. Timing for I²S Transmitters and Receivers

Parameter	Transmitter				Receiver	
	Lower Limit		Upper Limit		Lower Limit	
	Minimum	Maximum	Minimum	Maximum	Minimum	Maximum
Clock period T	T_{tr}	–	–	–	T_{tr}	–
Slave mode:						
Clock HIGH, t_{HC}	–	$0.35T_r$	–	–	–	$0.35T_r$
Clock LOW, t_{LC}	–	$0.35T_r$	–	–	–	$0.35T_r$
Clock rise time, t_{RC}	–	–	$0.15T_{tr}$	–	–	–
Transmitter delay, t_{dtr}	–	–	–	$0.8T$	–	–
Transmitter hold time, t_{htr}	0	–	–	–	–	–
Receiver setup time, t_{sr}	–	–	–	–	–	$0.2T_r$
Receiver hold time, t_{hr}	–	–	–	–	–	0

Table 45 provides the I2S_MCLK specification.

Table 45. I2S_MCLK Specification

Parameter	Minimum	Typical	Maximum	Unit
Frequency range	1	–	40	MHz
Frequency accuracy (with respect to the XTAL frequency)	–	1	–	ppb
Tuning resolution	–	50	–	ppb
Tuning range	–	1000	–	ppm
Tuning step size	–	–	10	ppm
Tuning rate	–	1	–	ppm/ms
Baseband jitter (100 Hz to 40 kHz)	–	–	100	ps rms
Wideband jitter (100 Hz to 1 MHz)	–	–	200	ps rms

Figure 22 shows the I²S frame-level timing.

Figure 22. I²S Frame-Level Timing

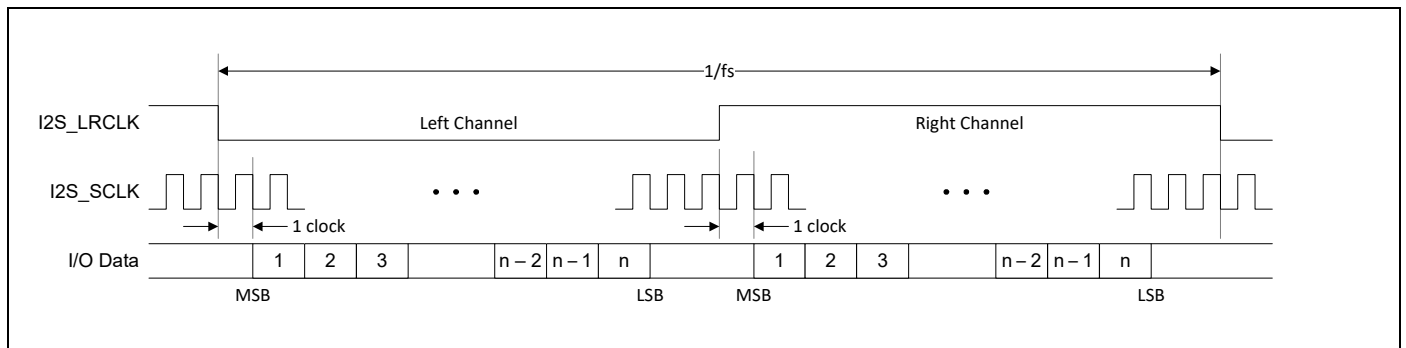

17.3 SDIO Interface Timing

17.3.1 SDIO Default-Speed Mode Timing

SDIO default-speed (DS) mode timing is shown by the combination of Figure 23 and Table 46.

Figure 23. SDIO Bus Timing (Default-Speed Mode)

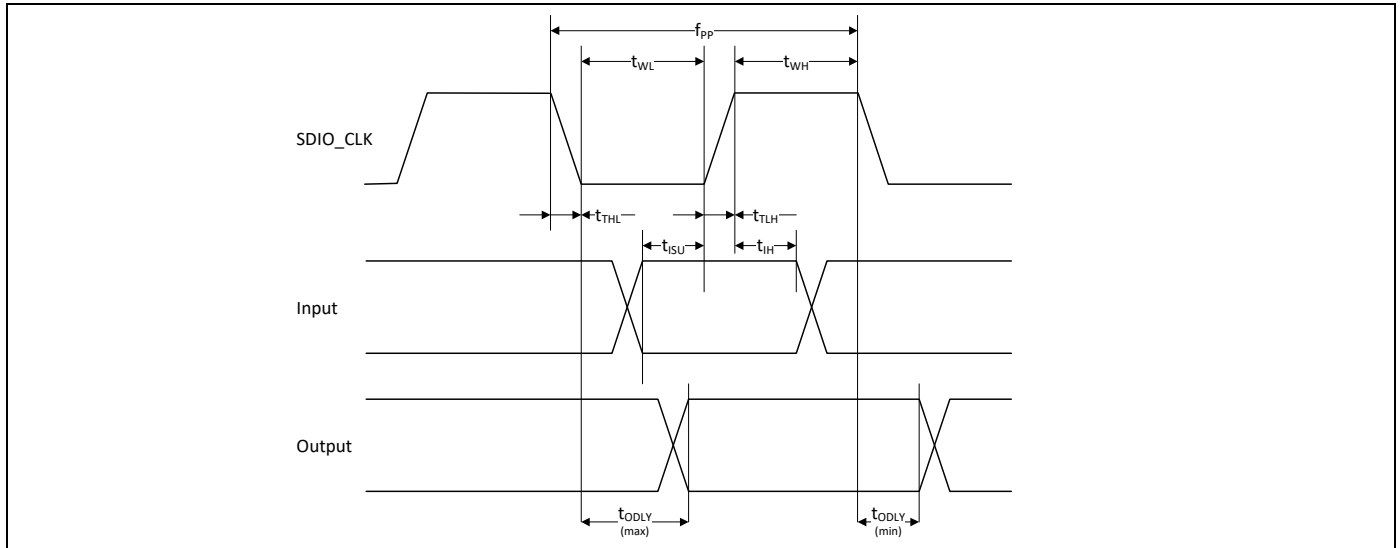

Table 46. SDIO Bus Timing^a Parameters (Default-Speed Mode)

Parameter	Symbol	Minimum	Typical	Maximum	Unit
SDIO_CLK or CLK—All values are referred to minimum VIH and maximum VIL^b					
Frequency – Data Transfer mode	f _{PP}	0	–	25	MHz
Frequency – Identification mode	f _{OD}	0	–	400	kHz
Clock low time	t _{WL}	10	–	–	ns
Clock high time	t _{WH}	10	–	–	ns
Clock rise time	t _{TLH}	–	–	10	ns
Clock low time	t _{THL}	–	–	10	ns
Inputs: CMD, DAT (referenced to CLK)					
Input setup time	t _{ISU}	5	–	–	ns
Input hold time	t _{IH}	5	–	–	ns
Outputs: CMD, DAT (referenced to CLK)					
Output delay time – Data Transfer mode	t _{ODLY}	0	–	14	ns
Output delay time – Identification mode	t _{ODLY}	0	–	50	ns

a. Timing is based on CL ≤ 40 pF load on CMD (command) and DAT (data) lines.

b. Min. (V_{ih}) = 0.7 × VDDIO and max. (V_{il}) = 0.2 × VDDIO.

17.3.2 SDIO High-Speed Mode Timing

SDIO high-speed (HS) mode timing is shown by the combination of Figure 24 and Table 47.

Figure 24. SDIO Bus Timing (High-Speed Mode)

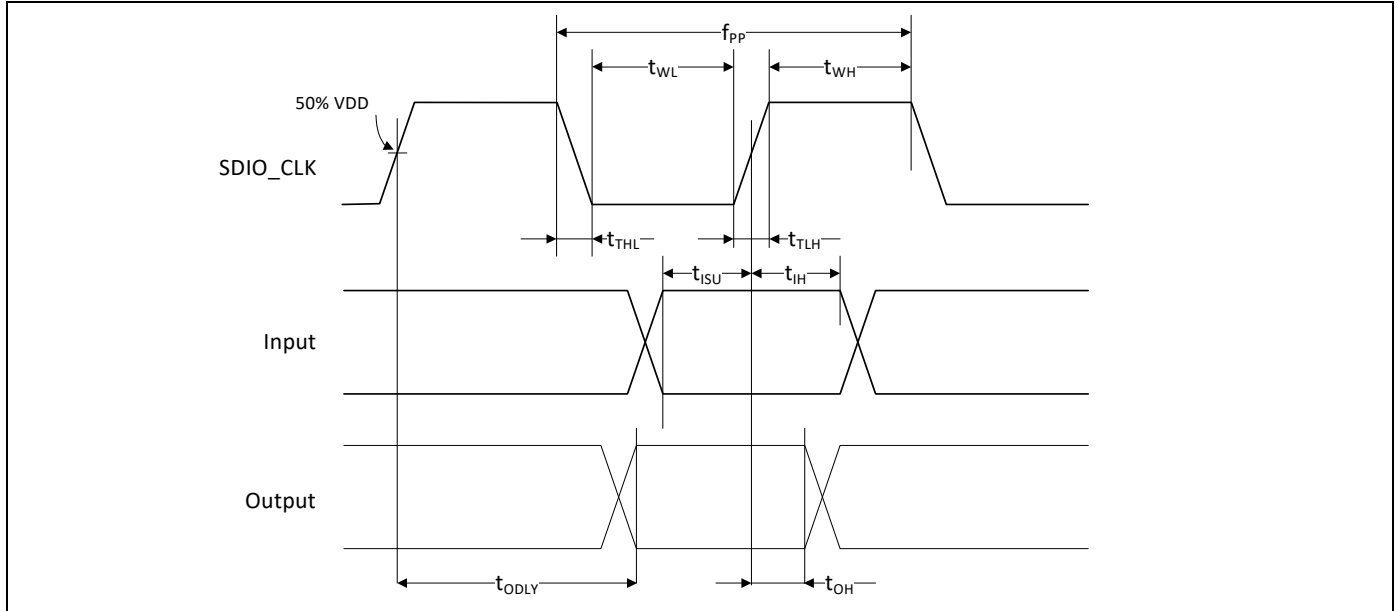

Table 47. SDIO Bus Timing^a Parameters (High-Speed Mode)

Parameter	Symbol	Minimum	Typical	Maximum	Unit
SDIO_CLK or CLK—All values are referred to minimum VIH and maximum VIL^b					
Frequency – Data Transfer Mode	f _{PP}	0	–	50	MHz
Frequency – Identification Mode	f _{OD}	0	–	400	kHz
Clock low time	t _{WL}	7	–	–	ns
Clock high time	t _{WH}	7	–	–	ns
Clock rise time	t _{TLH}	–	–	3	ns
Clock low time	t _{THL}	–	–	3	ns
Inputs: CMD, DAT (referenced to CLK)					
Input setup time	t _{ISU}	6	–	–	ns
Input hold time	t _{IH}	2	–	–	ns
Outputs: CMD, DAT (referenced to CLK)					
Output delay time – Data Transfer Mode	t _{ODLY}	–	–	14	ns
Output hold time	t _{OH}	2.5	–	–	ns
Total system capacitance (each line)	CL	–	–	40	pF

a. Timing is based on CL ≤ 40 pF load on CMD (command) and DAT (data) lines.

b. Min. (V_{Ih}) = 0.7 × VDDIO and max. (V_{Il}) = 0.2 × VDDIO.

17.3.3 SDIO Bus Timing Specifications in SDR Modes

Clock Timing

SDIO clock timing in the SDR modes is shown by the combination of Figure 25 and Table 48.

Figure 25. SDIO Clock Timing (SDR Modes)

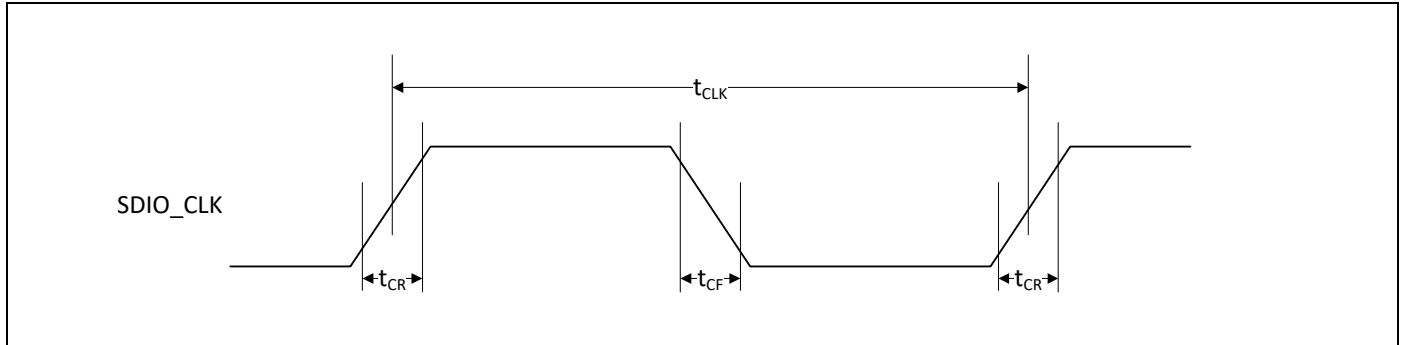

Table 48. SDIO Bus Clock Timing Parameters (SDR Modes)

Parameter	Symbol	Minimum	Maximum	Unit	Comments
–	t_{CLK}	40	–	ns	SDR12 mode
		20	–	ns	SDR25 mode
–	t_{CR}, t_{CF}	–	$0.2 \times t_{CLK}$	ns	$C_{CARD} = 10 \text{ pF}$
Clock duty cycle	–	30	70	%	–

Device Input Timing

SDIO device input timing in the SDR modes is shown by the combination of Figure 26 and Table 49.

Figure 26. SDIO Bus Input Timing (SDR Modes)

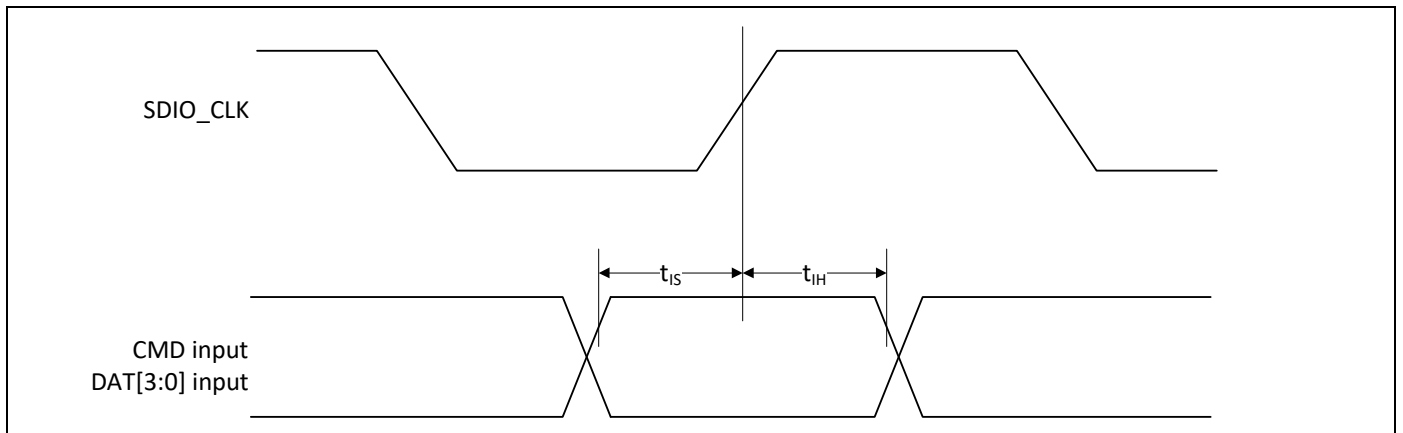

Table 49. SDIO Bus Input Timing Parameters (SDR Modes)

Symbol	Minimum	Maximum	Unit	Comments
t_{IS}	3.00	–	ns	$C_{CARD} = 10 \text{ pF}, V_{CT} = 0.975V$
t_{IH}	0.80	–	ns	$C_{CARD} = 5 \text{ pF}, V_{CT} = 0.975V$

Device Output Timing

SDIO device output timing in the SDR modes with clock rates up to 50 MHz is shown by the combination of Figure 27 and Table 50.

Figure 27. SDIO Bus Output Timing (SDR Modes up to 50 MHz)

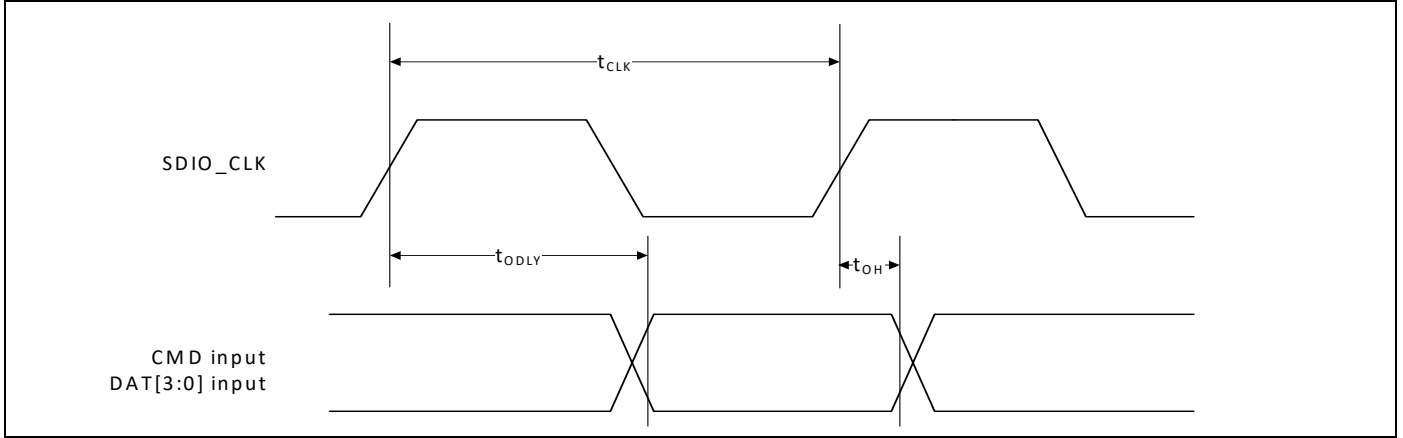

Table 50. SDIO Bus Output Timing Parameters (SDR Modes up to 50 MHz)

Symbol	Minimum	Maximum	Unit	Comments
t_{ODLY}	–	14.0	ns	$t_{CLK} \geq 20$ ns $C_L = 40$ pF
t_{OH}	1.5	–	ns	Hold time at the t_{ODLY} (min.) $C_L = 15$ pF

17.4 S/PDIF Interface Timing

The S/PDIF protocol embeds the clock and data within a stream of data using a Biphase Mark Code (BMC).

Figure 28 shows the S/PDIF interface timing.

Figure 28. S/PDIF Interface Timing

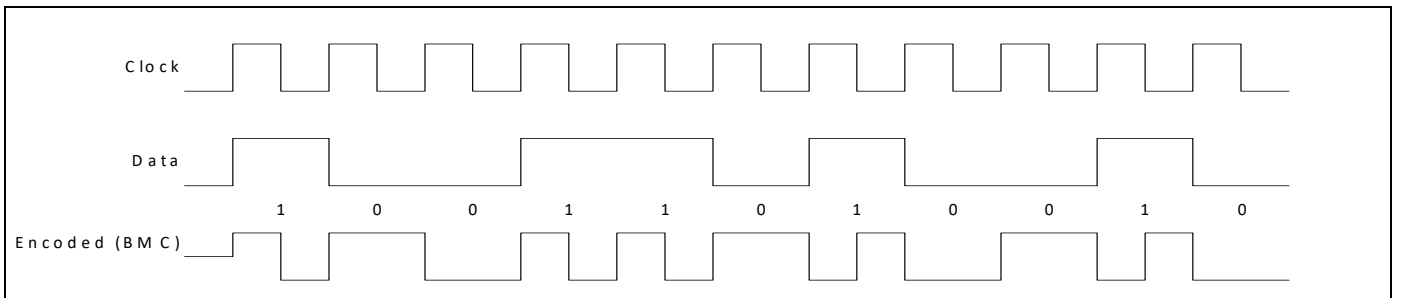

Figure 29 shows the S/PDIF data output timing.

Figure 29. S/PDIF Data Output Timing

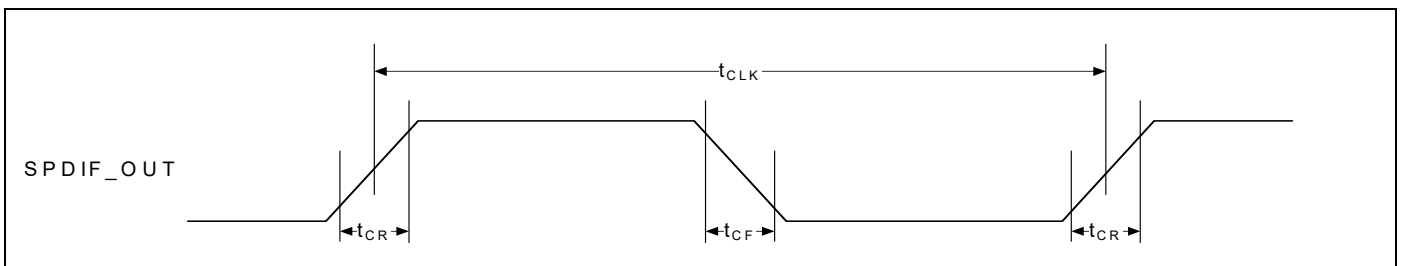

Table 51 provides the S/PDIF biphas mark code timing parameters (to be used in conjunction with Figure 29).

Table 51. SPDIF Biphas Mark Code Timing Parameters

Parameter	Symbol	Minimum	Maximum	Unit	Comments
–	t_{CLK}	40	–	ns	192 kHz sample rate
–	t_{CR}, t_{CF}	–	$0.3 \times t_{CLK}$	ns	–
Duty cycle	–	30	70	%	–

Table 52 provides the S/PDIF biphas mark code sample rate and receiver clock frequency.

Table 52. SPDIF Biphas Mark Code Sample Rate and Receiver Clock Frequency

Parameter	Symbol	Minimum	Maximum	Unit	Comments
Sampling frequency	f_S	–	192	kHz	192 kHz sample rate maximum.
Component clock frequency	f_{CLOCK}	–	25	MHz	Typical is $128 \times f_S$, max is $192 \times f_S$. Clock is $2 \times$ the desired data rate or $2 \times 192 \text{ kHz} \times 64 = 24.576 \text{ MHz}$.

17.5 SPI Flash Timing

17.5.1 Read-Register Timing

Figure 30 shows the SPI flash extended and quad read-register timing.

Note: Regarding Figure 30: All Read Register commands except Read Lock Register are supported. A Read Nonvolatile Configuration Register operation will output data starting from the least significant byte.

Figure 30. SPI Flash Read-Register Timing

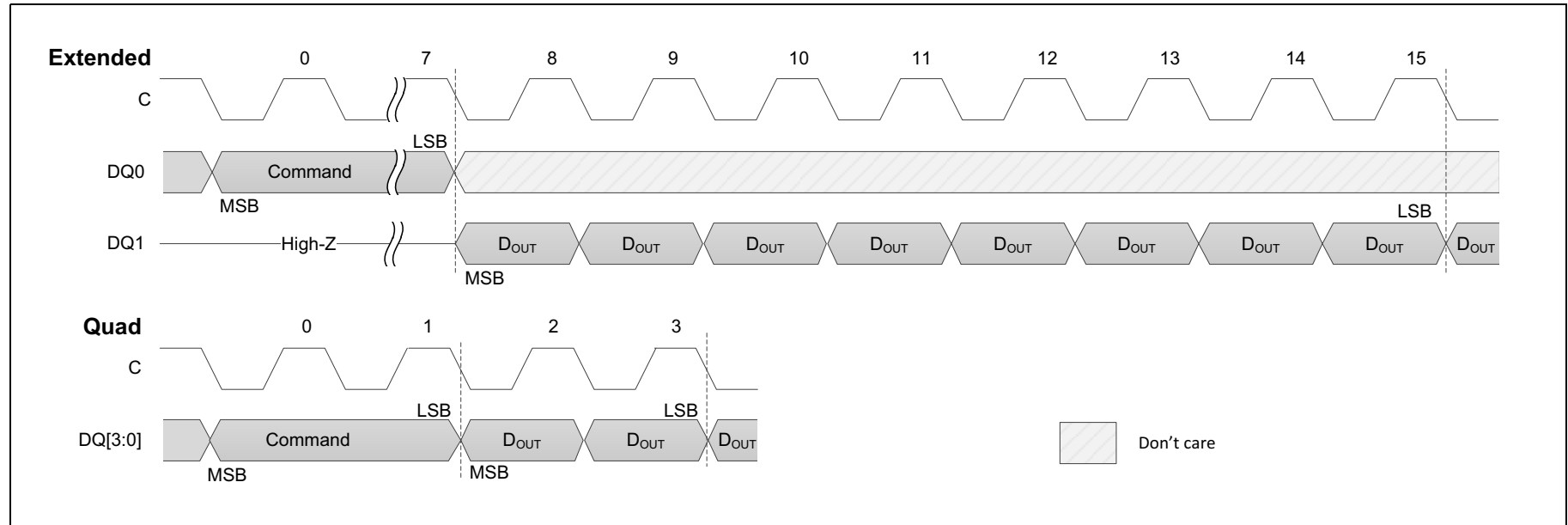

17.5.2 Write-Register Timing

Figure 31 shows the SPI flash extended and quad write-register timing.

Note: Regarding Figure 31:

1. All write-register commands except Write Lock Register are supported.
2. The waveform must be extended for each protocol: to 23 for extended and five for quad.
3. A Write Nonvolatile Configuration Register operation requires data being sent starting from the least significant byte.

Figure 31. SPI Flash Write-Register Timing

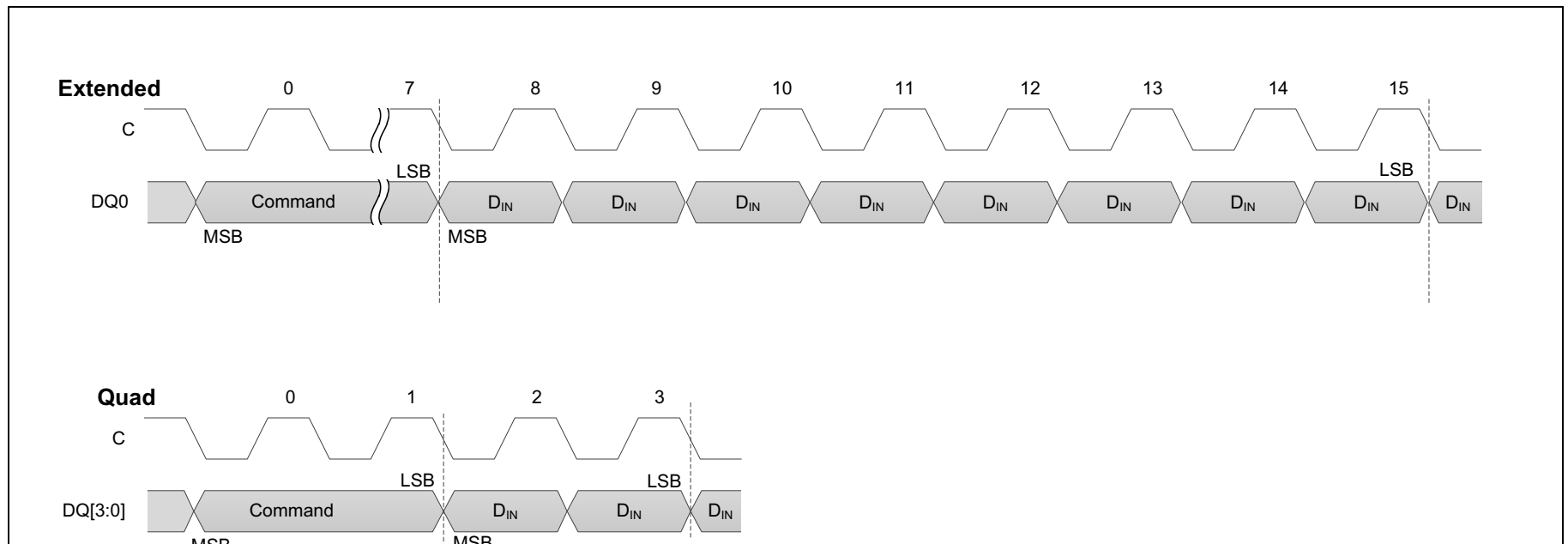

17.5.3 Memory Fast-Read Timing

Figure 32 shows the SPI flash extended and quad memory fast-read timing.

Note: Regarding Figure 32:

1. 24-bit addressing is used, so $A[\text{MAX}] = A[23]$ and $A[\text{MIN}] = A[0]$.
2. For an extended SPI protocol, $C_x = 7 + (A[\text{MAX}] + 1)$.
3. For a quad SPI protocol, $C_x = 1 + (A[\text{MAX}] + 1)/4$.

Figure 32. Memory Fast-Read Timing

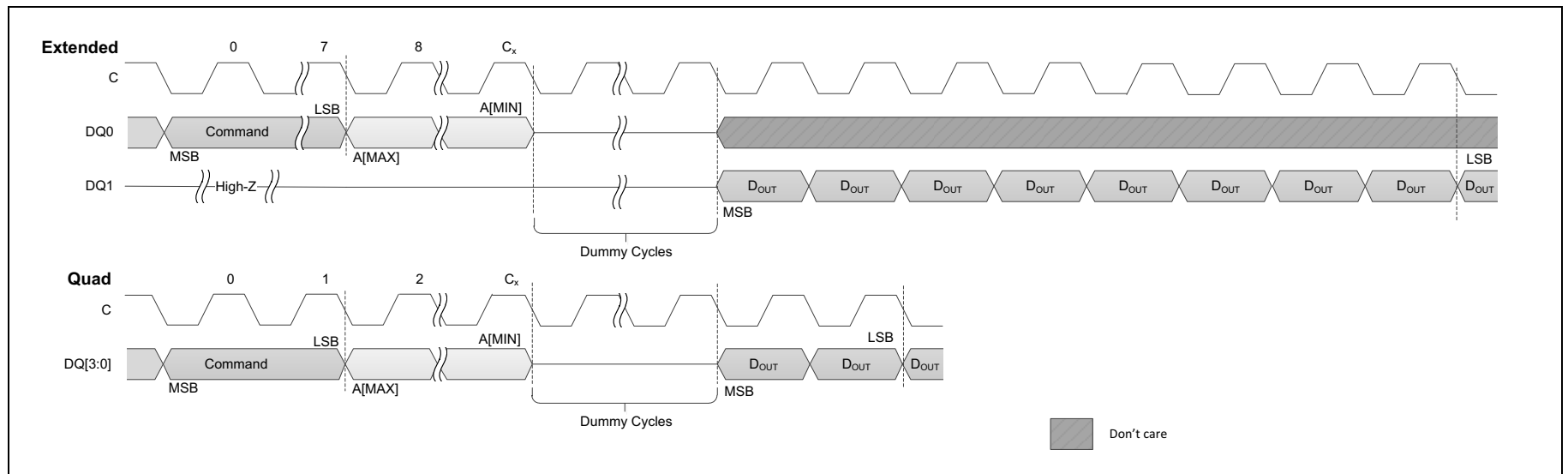

17.5.4 Memory-Write Timing

Figure 33 shows the SPI flash extended and quad memory-write (Page Program) timing.

Note: Regarding Figure 33:

1. For an extended SPI protocol, $C_x = 7 + (A[MAX] + 1)$.
2. For a quad SPI protocol, $C_x = 1 + (A[MAX] + 1)/4$.

Figure 33. Memory-Write Timing

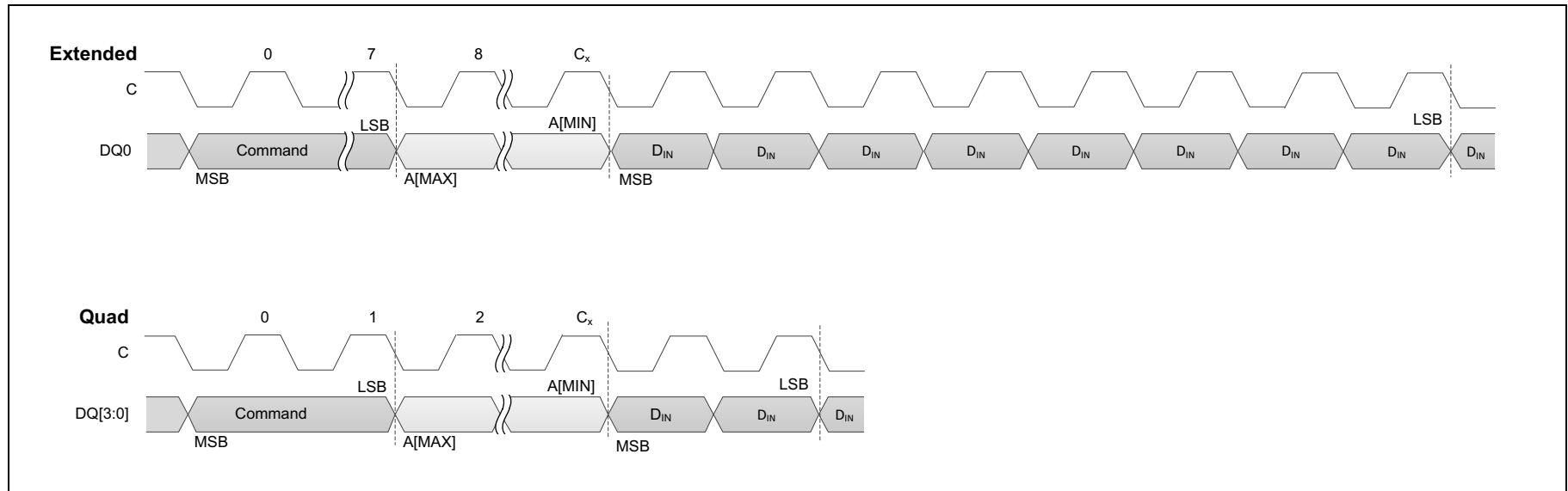

17.5.5 SPI Flash Parameters

The combination of Figure 34 and Table 53 provide the SPI flash timing parameters.

Figure 34. SPI Flash Timing Parameters Diagram

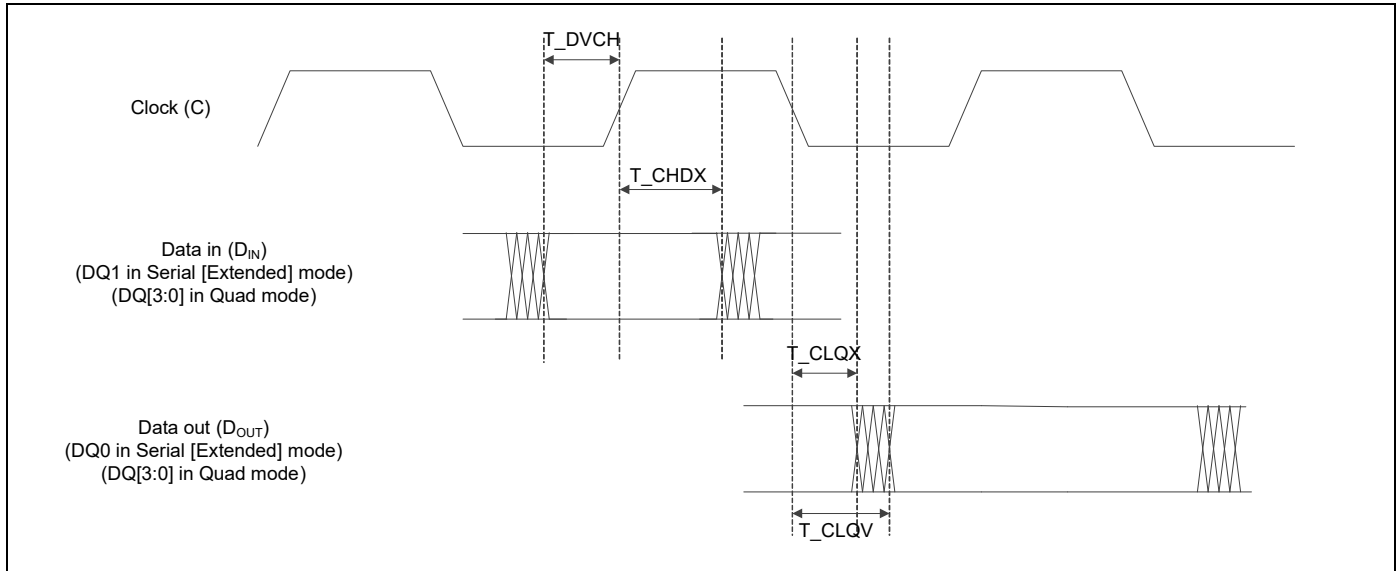

Table 53. SPI Flash Timing Parameters

Parameter	Description	Minimum	Maximum	Units
T _{DVCH}	Data setup time	2	–	ns
T _{CHDX}	Data hold time	3	–	ns
T _{CLQX}	Output hold time	1	–	ns
T _{CLQV}	Output valid time (with a 10 pF load)	–	5	ns

17.6 USB PHY Electrical Characteristics and Timing

17.6.1 USB 2.0 and USB 1.1 Electrical and Timing Parameters

Table 54 provides electrical and timing parameters for USB 2.0.

Table 54. USB 2.0 Electrical and Timing Parameters

Parameter	Symbol	Minimum	Typical	Maximum	Units	Conditions
Baud rate	B _{PS}	–	480	–	Mbps	–
Unit interval	UI	–	2083	–	ps	–
Receiver – HS Mode						
Differential input voltage sensitivity	V _{HSDI}	300	–	–	mV	Static V _{IDP} – V _{IDN}
Input common mode voltage range	V _{HSCM}	–50	–	500	mV	–
Receiver jitter tolerance	ΔT _{HSRX}	–0.15	–	0.15	UI	–
Input impedance	R _{IN}	40.5	45	49.5	Ω	Single ended
Transmitter – HS Mode						
Output high voltage	V _{H_{SOH}}	360	400	440	mV	Static condition
Output low voltage	V _{H_{SOL}}	–10	0	10	mV	Static condition
Output rise time	T _{H_{SR}}	500	–	–	ps	10% to 90%

Table 54. USB 2.0 Electrical and Timing Parameters (Cont.)

Parameter	Symbol	Minimum	Typical	Maximum	Units	Conditions
Output fall time	T_{HSF}	500	–	–	ps	90% to 10%
Transmitter jitter	ΔT_{HSTX}	–0.05	–	0.05	UI	Transmit output jitter
Output impedance	R_O	40.5	45	49.5	Ω	Single ended
Chirp-J output voltage (differential)	V_{CHIRPJ}	700	–	1100	mV	HS termination disabled. 1.5 k Ω \pm 5% pull-up resistor connected.
Chirp-K output voltage (differential)	V_{CHIRPK}	–900	–	–500	mV	HS termination disabled. 1.5 k Ω \pm 5% pull-up resistor connected.

Note: Refer to Section 7 of the USB 2.0 specification (www.usb.org) for more information on the receiver eye diagram template.

Table 55 provides electrical and timing parameters for USB 1.1.

Table 55. USB 1.1 FS/LS Electrical and Timing Parameters ^a

Parameter	Symbol	Value			Unit	Condition
		Minimum	Typical	Maximum		
Baud Rate						
FS	B_{PS}	–	12	–	Mbps	–
LS	B_{PS}	–	1.5	–	Mbps	–
Unit Interval						
FS	UI	–	83.33	–	ns	–
LS	UI	–	666.67	–	ns	–
Receiver						
Differential input sensitivity	V_{FSDI}	200	–	–	mV	Static $ V_{IDP} - V_{IDN} $
Input common mode range	V_{FSCM}	0.8	–	2.5	V	–
Input impedance	Z_{IN}	300	–	–	k Ω	–
Input high voltage	V_{FSIH}	2.0	–	–	V	Static
Input low voltage	V_{FSIL}	–	–	0.8	V	Static
Transmitter						
Output high voltage	V_{FSOH}	2.8	–	–	V	Static
Output low voltage	V_{FSOL}	–	–	0.3	V	Static
Output rise/fall time for fast speed	T_{R,T_F}	4	–	20	ns	10 to 90%
Output rise/fall time for low speed	T_{R,T_F}	75	–	300	ns	10 to 90%
Fast-speed jitter	$\Delta\tau_{FSTX}$	–2	–	2	ns	–
Low-speed jitter	$\Delta\tau_{LSTX}$	–25	–	25	ns	–
Output impedance	R_O	28	–	44	Ω	Single ended

a. For more details, refer to the *USB 1.1 Specification*.

17.6.2 USB 2.0 Timing Diagrams

Figure 35 shows the important timing parameters associated with a post-reset transition to high-speed (HS) operation.

Figure 35. USB 2.0 Bus Reset to High-Speed Mode Operation

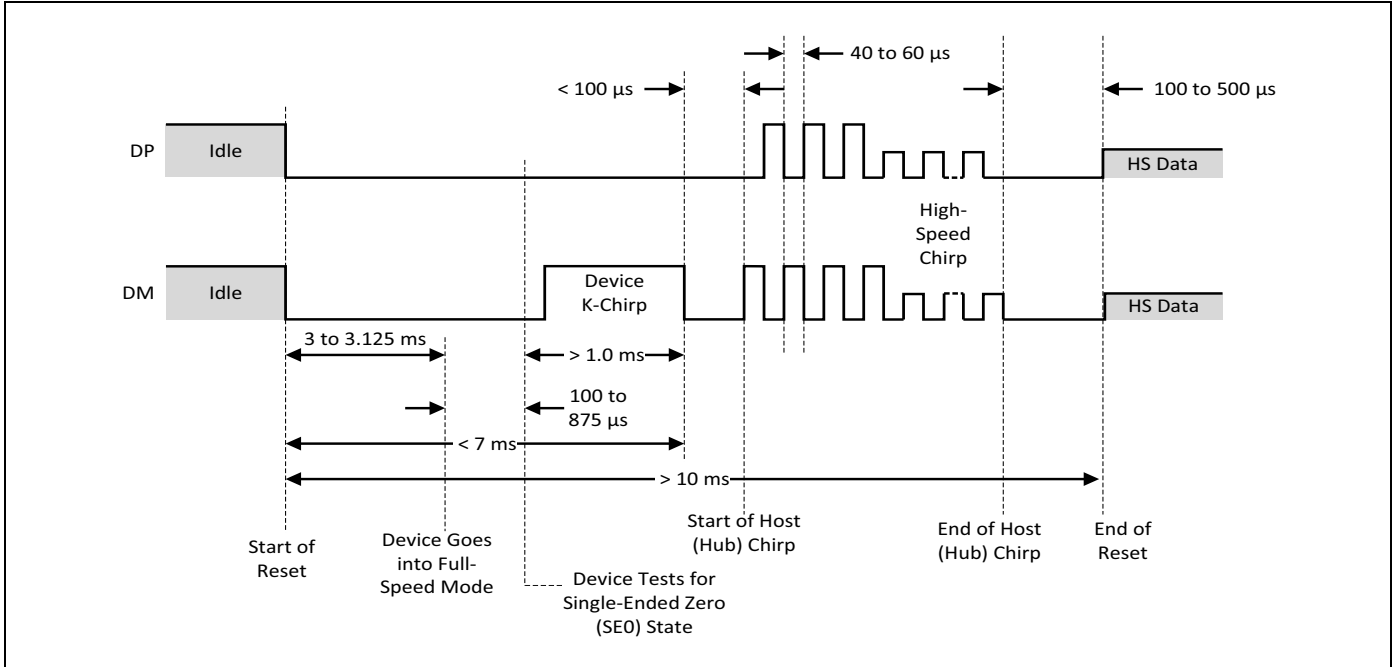

Figure 36 shows the USB 2.0 HS Mode transmit timing.

Figure 36. USB 2.0 High-Speed Mode Transmit Timing

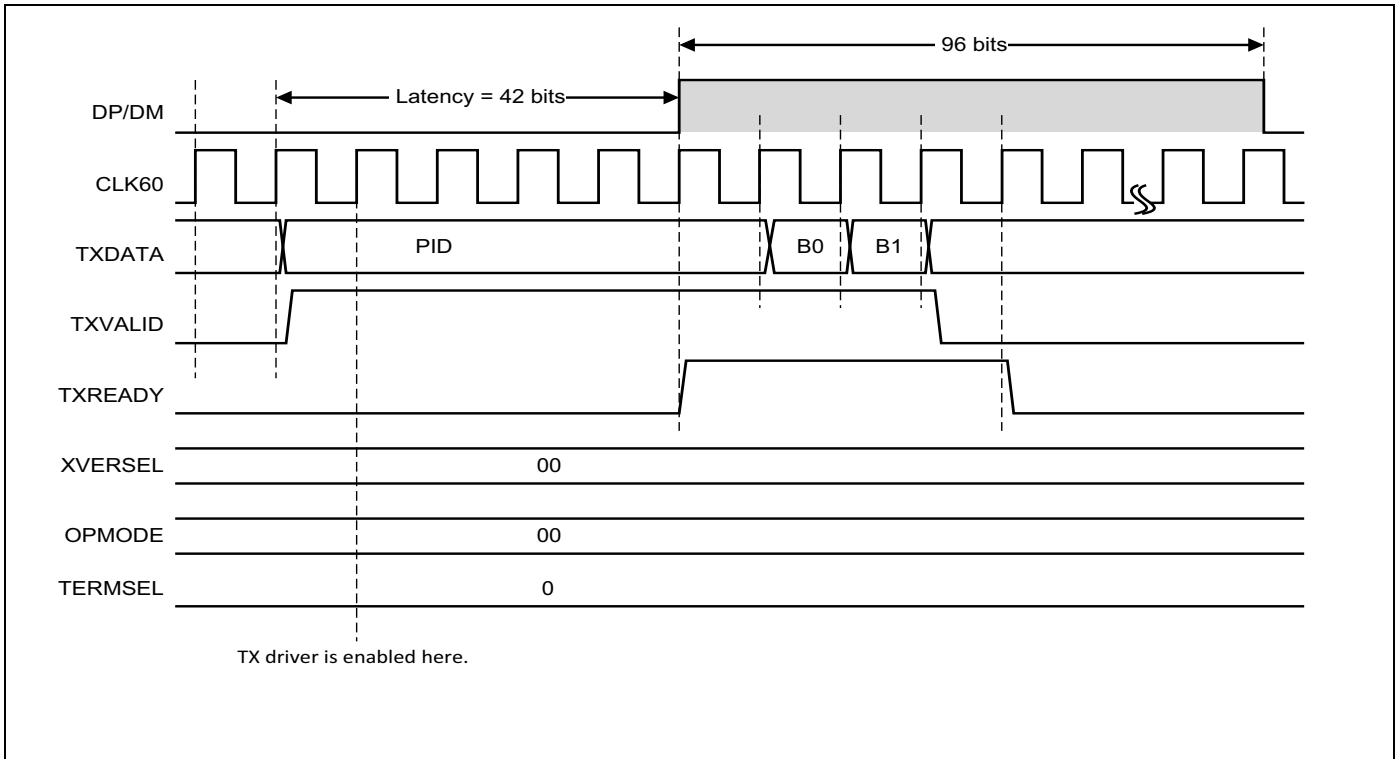
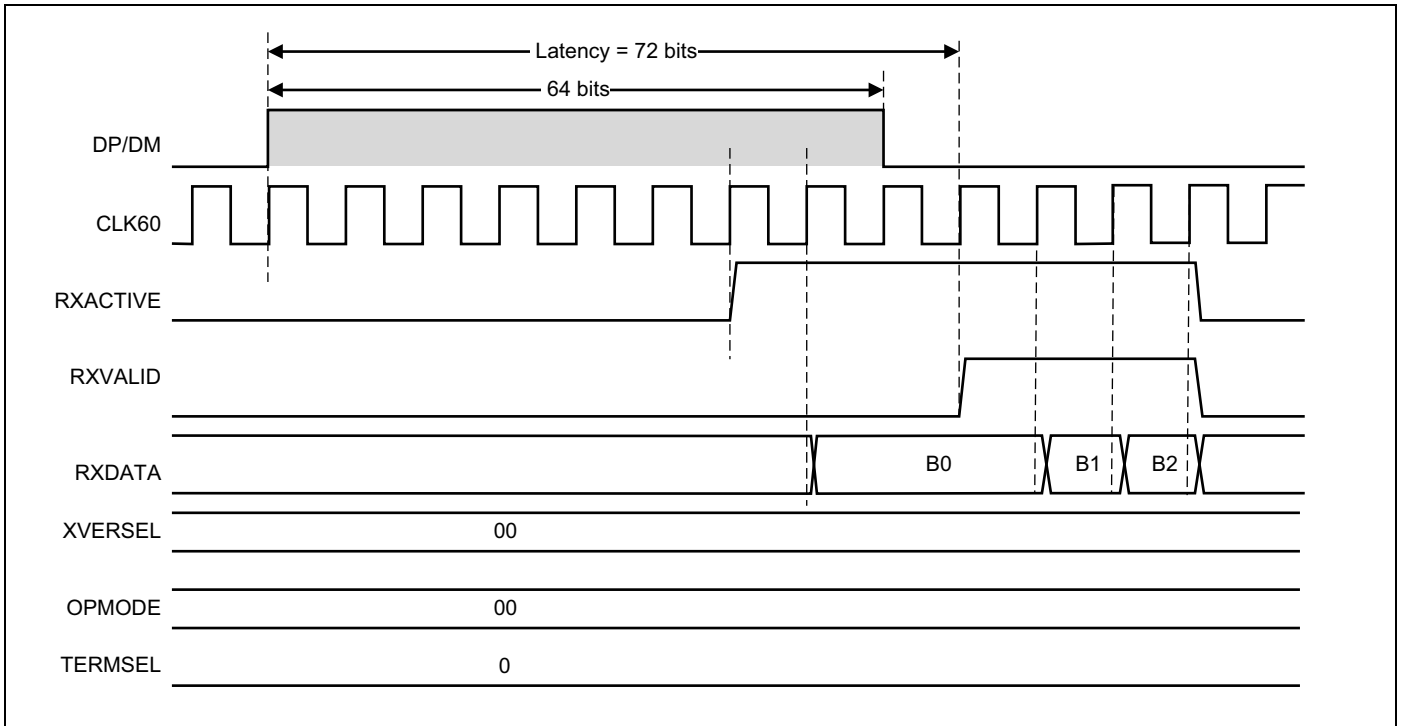

Figure 37 shows the USB 2.0 HS Mode receive timing.

Figure 37. USB 2.0 High-Speed Mode Receive Timing



18. Power-Up Sequence and Timing

18.1 Sequencing of Reset and Regulator Control Signals

The CYW54907 has two signals that allow the host to control power consumption by enabling or disabling the internal regulator blocks. These signals are described below. Additionally, diagrams are provided to indicate proper sequencing of the signals for various operational states (see [Figure 38](#) and [Figure 39](#)). The timing values indicated are minimum required values; longer delays are also acceptable.

18.1.1 Description of Control Signals

- **REG_ON**: Used by the PMU to power-up the CYW54907. It controls the internal CYW54907 regulators. When this pin is high, the regulators are enabled and the device is out of reset. When this pin is low the regulators are disabled.
- **HIB_REG_ON_IN**: Used by the Hibernation (HIB) block to power up the internal CYW54907 regulators. If the HIB_REG_ON_IN pin is low, the regulators are disabled. For the HIB_REG_ON_IN pin to work as designed, HIB_REG_ON_OUT must be connected to REG_ON.

Note: The CYW54907 has an internal power-on reset (POR) circuit. The device will be held in reset for a maximum of 110 ms after VDDC and VDDIO have both passed the POR threshold.

Note: The 10%–90% VBAT rise time should not be faster than 40 microseconds. VBAT should be up before or at the same time as VDDIO. VDDIO should not be present first or be held high before VBAT is high.

18.1.2 Control Signal Timing Diagrams

Figure 38. REG_ON = High, No HIB_REG_ON_OUT Connection to REG_ON

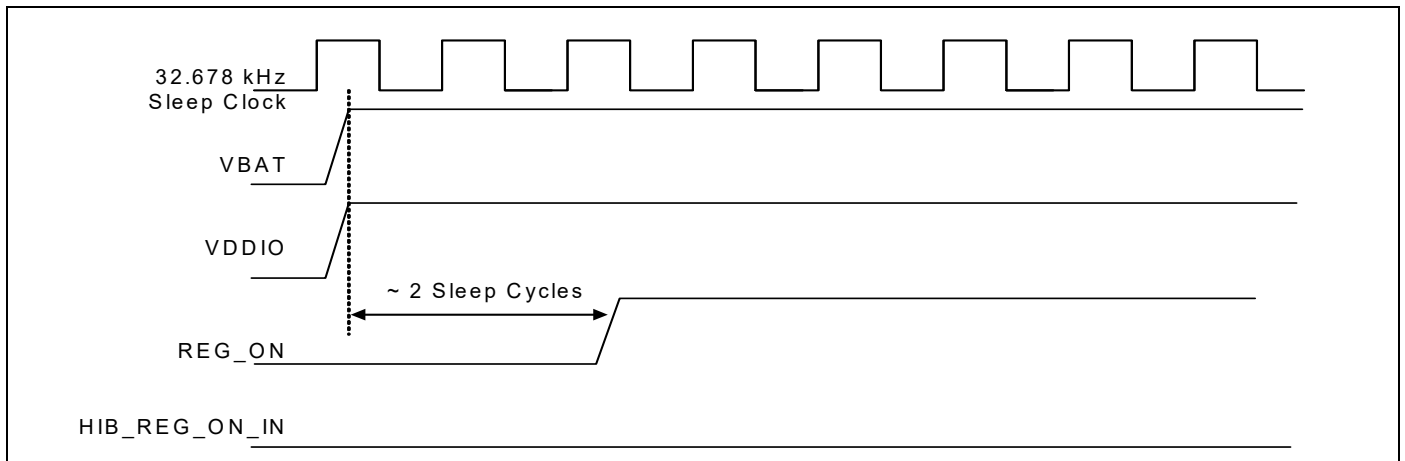
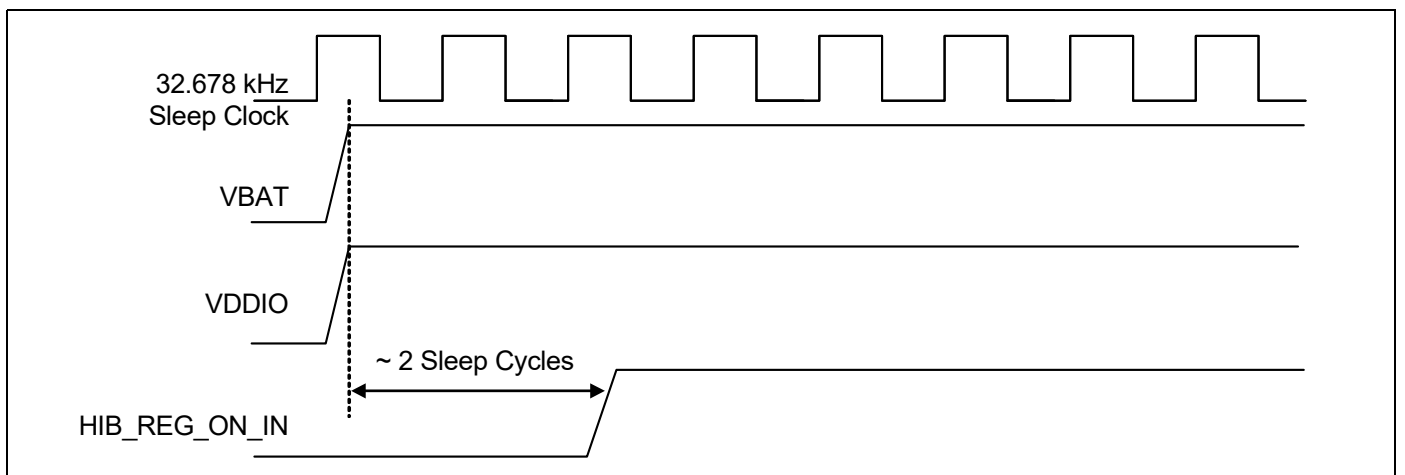

Figure 39. HIB_REG_ON_IN = High, HIB_REG_ON_OUT Connected to REG_ON



19. Thermal Information

19.1 Package Thermal Characteristics

Table 56. Package Thermal Characteristics^a

Characteristic	WLCSP
θ_{JA} (°C/W) (value in still air)	33.74
θ_{JB} (°C/W)	5.5
θ_{JC} (°C/W)	1.74
ψ_{JT} (°C/W)	5.86
ψ_{JB} (°C/W)	11.52
Maximum Junction Temperature T_j (°C)	116.7
Maximum power dissipation (W)	1.38

a. No heat sink, $T_A = 70^\circ\text{C}$. This is an estimate based on a 4-layer PCB that conforms to EIA/JESD51-7. Air velocity is 0 m/s.

19.2 Junction Temperature Estimation and ψ_{JT} Versus θ_{JC}

Package thermal characterization parameter ψ_{JT} (ψ_{JT}) yields a better estimation of actual junction temperature (T_j) versus using the junction-to-case thermal resistance parameter θ_{JC} (θ_{JC}). The reason for this is that θ_{JC} assumes that all the power is dissipated through the top surface of the package case. In actual applications, some of the power is dissipated through the bottom and sides of the package. ψ_{JT} takes into account power dissipated through the top, bottom, and sides of the package. The equation for calculating the device junction temperature is:

$$T_j = T_T + P \times \psi_{JT}$$

Where:

- T_j = Junction temperature at steady-state condition (°C)
- T_T = Package case top center temperature at steady-state condition (°C)
- P = Device power dissipation (Watts)
- ψ_{JT} = Package thermal characteristics; no airflow (°C/W)

19.3 Environmental Characteristics

For environmental characteristics data, see [Table 16: "Environmental Ratings"](#).

20. Mechanical Information

Figure 40. WLCSP Package

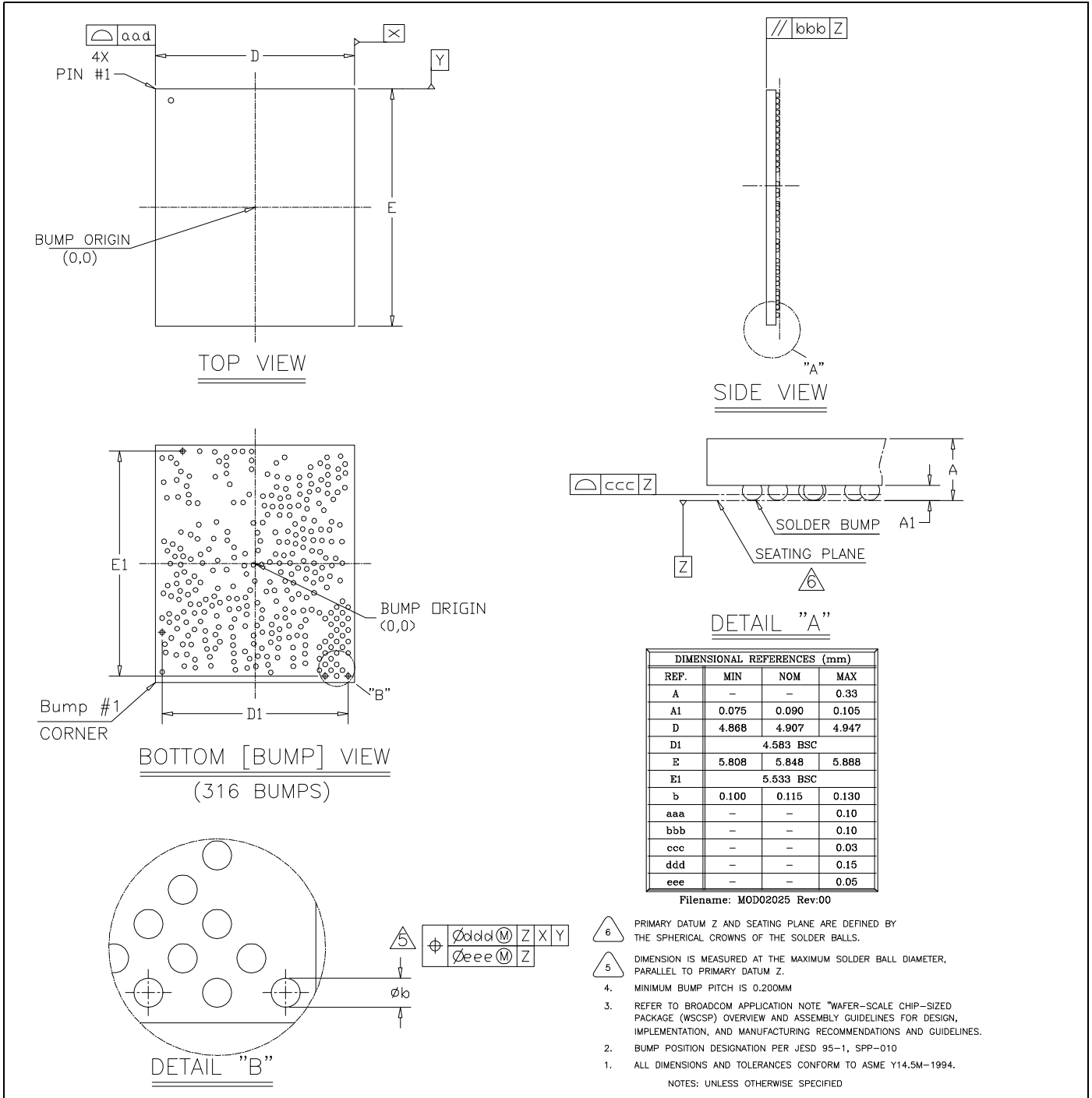

21. Ordering Information

Part Number	Package	Description	Operating Ambient Temperature
CYW54907KWBG	4.583 mm x 5.533 mm, 316-pin WLCSP	–	–30°C to +85°C

22. Additional Information

22.1 Acronyms and Abbreviations

In most cases, acronyms and abbreviations are defined upon first use. For a more complete list of acronyms and other terms used in Cypress documents, go to: <http://www.cypress.com/glossary>.

22.2 References

The references in this section may be used in conjunction with this document.

Note: Cypress provides customer access to technical documentation and software through its Customer Support Portal (CSP) and Downloads and Support site (see [IoT Resources](#)).

Document (or Item) Name	Number	Source
1. USB 2.0 specification	–	Wiced-smart
2. USB 1.1 Specification	–	Wiced-smart

22.3 IoT Resources

Cypress provides a wealth of data at <http://www.cypress.com/internet-things-iot> to help you to select the right IoT device for your design, and quickly and effectively integrate the device into your design. Cypress provides customer access to a wide range of information, including technical documentation, schematic diagrams, product bill of materials, PCB layout information, and software updates. Customers can acquire technical documentation and software from the Cypress Support Community website (<https://community.cypress.com/>)

22.4 Errata

- The RTC block has been deprecated from this datasheet in revision *A and later. This block is used by Cypress for internal testing/validation/verification and is not intended for customers to use.
- The details of the SPI hardware blocks were missing from this datasheet till revision *A. Revision *B adds this in section 5.12. Note that the SPI hardware blocks can only support a hold time of 25ns and a fixed SPI mode (CPHA=0, CPOL = 0). For slaves that require higher hold times or a different mode a bit banging based SPI driver is recommended.
- The clock for the SPI Flash block needs to be constrained to ~26.67MHz for reliable operation at high operating temperatures. The throughput of the SPI Flash block is therefore restricted to ~13 MBps for Quad mode and ~3 MBps for single mode.

Document History Page

Document Title: CYW54907 WICED™ IEEE 802.11 a/b/g/n/ac SoC with an Embedded Applications Processor				
Document Number: 002-19312				
Revision	ECN	Orig. of Change	Submission Date	Description of Change
**	5742421	UTSV	05/19/2017	New datasheet.
*A	5812137	UTSV	07/12/2017	Updated 5.7.2.SDIO 3.0—Host Mode on page 20 . Added: Note: JTAG_SEL is exposed on a dedicated physical pin. TAP_SEL uses the GPIO_8 physical pin below Table 6. Updated Table 17 on page 51 .
*B	5954959	UTSV	11/02/2017	Added 5.12.SPI on page 23 . Added a Note: “ The SPI blocks can be re-purposed as I2C, however the WICED SDK does not support this. Certain I2C features may be unavailable when using the SPI blocks as I2C. Therefore Cypress recommends using the the CSC blocks or a bit banging I2C driver over GPIOs instead. ” below Table 10 on page 38 . Added a 22.4.Errata on page 93 section.
*C	5999198	UTSV	12/22/2017	Updated Table 26 on page 61 . Updated Note “ Note that the clock needs to be constrained to ~26.67MHz for reliable operation at high operating temperatures. The throughput of the SPI Flash block is therefore restricted to ~13 MBps for Quad mode and ~3 MBps for single mode ” for 5.9.SPI Flash on page 20 . Updated 22.4.Errata on page 93 .

Sales, Solutions, and Legal Information

Worldwide Sales and Design Support

Cypress maintains a worldwide network of offices, solution centers, manufacturer's representatives, and distributors. To find the office closest to you, visit us at [Cypress Locations](#).

Products

Arm® Cortex® Microcontrollers	cypress.com/arm
Automotive	cypress.com/automotive
Clocks & Buffers	cypress.com/clocks
Interface	cypress.com/interface
Internet of Things	cypress.com/iot
Memory	cypress.com/memory
Microcontrollers	cypress.com/mcu
PSoC	cypress.com/psoc
Power Management ICs	cypress.com/pmic
Touch Sensing	cypress.com/touch
USB Controllers	cypress.com/usb
Wireless Connectivity	cypress.com/wireless

PSoC® Solutions

[PSoC 1](#) | [PSoC 3](#) | [PSoC 4](#) | [PSoC 5LP](#) | [PSoC 6](#)

Cypress Developer Community

[Forums](#) | [WICED IoT Forums](#) | [Projects](#) | [Video](#) | [Blogs](#) | [Training](#) | [Components](#)

Technical Support

cypress.com/support

© Cypress Semiconductor Corporation, 2017. This document is the property of Cypress Semiconductor Corporation and its subsidiaries, including Spansion LLC ("Cypress"). This document, including any software or firmware included or referenced in this document ("Software"), is owned by Cypress under the intellectual property laws and treaties of the United States and other countries worldwide. Cypress reserves all rights under such laws and treaties and does not, except as specifically stated in this paragraph, grant any license under its patents, copyrights, trademarks, or other intellectual property rights. If the Software is not accompanied by a license agreement and you do not otherwise have a written agreement with Cypress governing the use of the Software, then Cypress hereby grants you a personal, non-exclusive, nontransferable license (without the right to sublicense) (1) under its copyright rights in the Software (a) for Software provided in source code form, to modify and reproduce the Software solely for use with Cypress hardware products, only internally within your organization, and (b) to distribute the Software in binary code form externally to end users (either directly or indirectly through resellers and distributors), solely for use on Cypress hardware product units, and (2) under those claims of Cypress's patents that are infringed by the Software (as provided by Cypress, unmodified) to make, use, distribute, and import the Software solely for use with Cypress hardware products. Any other use, reproduction, modification, translation, or compilation of the Software is prohibited.

TO THE EXTENT PERMITTED BY APPLICABLE LAW, CYPRESS MAKES NO WARRANTY OF ANY KIND, EXPRESS OR IMPLIED, WITH REGARD TO THIS DOCUMENT OR ANY SOFTWARE OR ACCOMPANYING HARDWARE, INCLUDING, BUT NOT LIMITED TO, THE IMPLIED WARRANTIES OF MERCHANTABILITY AND FITNESS FOR A PARTICULAR PURPOSE. No computing device can be absolutely secure. Therefore, despite security measures implemented in Cypress hardware or software products, Cypress does not assume any liability arising out of any security breach, such as unauthorized access to or use of a Cypress product. In addition, the products described in these materials may contain design defects or errors known as errata which may cause the product to deviate from published specifications. To the extent permitted by applicable law, Cypress reserves the right to make changes to this document without further notice. Cypress does not assume any liability arising out of the application or use of any product or circuit described in this document. Any information provided in this document, including any sample design information or programming code, is provided only for reference purposes. It is the responsibility of the user of this document to properly design, program, and test the functionality and safety of any application made of this information and any resulting product. Cypress products are not designed, intended, or authorized for use as critical components in systems designed or intended for the operation of weapons, weapons systems, nuclear installations, life-support devices or systems, other medical devices or systems (including resuscitation equipment and surgical implants), pollution control or hazardous substances management, or other uses where the failure of the device or system could cause personal injury, death, or property damage ("Unintended Uses"). A critical component is any component of a device or system whose failure to perform can be reasonably expected to cause the failure of the device or system, or to affect its safety or effectiveness. Cypress is not liable, in whole or in part, and you shall and hereby do release Cypress from any claim, damage, or other liability arising from or related to all Unintended Uses of Cypress products. You shall indemnify and hold Cypress harmless from and against all claims, costs, damages, and other liabilities, including claims for personal injury or death, arising from or related to any Unintended Uses of Cypress products.

Cypress, the Cypress logo, Spansion, the Spansion logo, and combinations thereof, WICED, PSoC, CapSense, EZ-USB, F-RAM, and Traveo are trademarks or registered trademarks of Cypress in the United States and other countries. For a more complete list of Cypress trademarks, visit cypress.com. Other names and brands may be claimed as property of their respective owners.

Компания «Океан Электроники» предлагает заключение долгосрочных отношений при поставках импортных электронных компонентов на взаимовыгодных условиях!

Наши преимущества:

- Поставка оригинальных импортных электронных компонентов напрямую с производств Америки, Европы и Азии, а так же с крупнейших складов мира;
- Широкая линейка поставок активных и пассивных импортных электронных компонентов (более 30 млн. наименований);
- Поставка сложных, дефицитных, либо снятых с производства позиций;
- Оперативные сроки поставки под заказ (от 5 рабочих дней);
- Экспресс доставка в любую точку России;
- Помощь Конструкторского Отдела и консультации квалифицированных инженеров;
- Техническая поддержка проекта, помощь в подборе аналогов, поставка прототипов;
- Поставка электронных компонентов под контролем ВП;
- Система менеджмента качества сертифицирована по Международному стандарту ISO 9001;
- При необходимости вся продукция военного и аэрокосмического назначения проходит испытания и сертификацию в лаборатории (по согласованию с заказчиком);
- Поставка специализированных компонентов военного и аэрокосмического уровня качества (Xilinx, Altera, Analog Devices, Intersil, Interpoint, Microsemi, Actel, Aeroflex, Peregrine, VPT, Syfer, Eurofarad, Texas Instruments, MS Kennedy, Miteq, Cobham, E2V, MA-COM, Hittite, Mini-Circuits, General Dynamics и др.);

Компания «Океан Электроники» является официальным дистрибьютором и эксклюзивным представителем в России одного из крупнейших производителей разъемов военного и аэрокосмического назначения «**JONHON**», а так же официальным дистрибьютором и эксклюзивным представителем в России производителя высокотехнологичных и надежных решений для передачи СВЧ сигналов «**FORSTAR**».



JONHON

«**JONHON**» (основан в 1970 г.)

Разъемы специального, военного и аэрокосмического назначения:

(Применяются в военной, авиационной, аэрокосмической, морской, железнодорожной, горно- и нефтедобывающей отраслях промышленности)

«**FORSTAR**» (основан в 1998 г.)

ВЧ соединители, коаксиальные кабели,
кабельные сборки и микроволновые компоненты:

(Применяются в телекоммуникациях гражданского и специального назначения, в средствах связи, РЛС, а так же военной, авиационной и аэрокосмической отраслях промышленности).



Телефон: 8 (812) 309-75-97 (многоканальный)

Факс: 8 (812) 320-03-32

Электронная почта: ocean@oceanchips.ru

Web: <http://oceanchips.ru/>

Адрес: 198099, г. Санкт-Петербург, ул. Калинина, д. 2, корп. 4, лит. А