



MAX17113 Evaluation Kit

Evaluates: MAX17113

General Description

The MAX17113 evaluation kit (EV kit) is a fully assembled and tested surface-mount PCB that provides the voltages and features required for thin-film transistor (TFT) liquid-crystal display (LCD) TV panels. The EV kit includes a step-down switching regulator, a step-up switching regulator, a positive two-stage charge pump for the TFT gate-on supply, and a negative single-stage charge pump for the TFT gate-off supply.

The MAX17113 EV kit operates from a DC supply voltage of +10.8V to +13.2V, as configured. The step-down switching regulator is configured for a +3.3V output providing at least 2A. The step-up switching regulator is configured for a +16V output providing at least 1.5A. The positive charge pump is configured for a +35V output providing at least 100mA. The negative charge pump is configured for a -6V output providing at least 100mA.

Features

- ◆ **+10.8V to +13.2V Supply Voltage**
- ◆ **Output Voltages**
 - +3.3V at 2A (Step-Down Switching Regulator)**
 - +16V at 1.5A (Step-Up Switching Regulator)**
 - +35V at 100mA (Positive Charge Pump)**
 - 6V at 100mA (Negative Charge Pump)**
- ◆ **Adjustable Output Voltages (External Resistors)**
- ◆ **Selectable Frequency (450kHz/600kHz)**
- ◆ **Low-Profile Surface-Mount Components**
- ◆ **Fully Assembled and Tested**

Ordering Information

PART	TYPE
MAX17113EVKIT+	EV Kit

+Denotes lead(Pb)-free and RoHS compliant.

Component List

DESIGNATION	QTY	DESCRIPTION
C1, C2, C5	3	22 μ F \pm 20%, 16V X5R ceramic capacitors (1206) Murata GRM31CR61C226M
C3	1	10 μ F \pm 20%, 16V X5R ceramic capacitor (1206) Murata GRM31CR61C106K TDK C3216X5R1C106M
C4, C7, C11, C14, C23, C24, C25	7	0.1 μ F \pm 10%, 50V X7R ceramic capacitors (0603) Murata GRM188R71H104K TDK C1608X7R1H104K
C6	0	Not installed, capacitor (1210)
C8, C15	2	1 μ F \pm 10%, 16V X5R ceramic capacitors (0603) Murata GRM188R71C105K TDK C1608X5R1C105K
C9	1	220pF \pm 10%, 50V X7R ceramic capacitor (0603) Murata GRM188R71H221K TDK C1608X7R1H221K

DESIGNATION	QTY	DESCRIPTION
C10	1	0.22 μ F \pm 10%, 10V X7R ceramic capacitor (0603) Taiyo Yuden LMK107BJ224KA TDK C1608X7R1A224K
C12, C13	2	0.15 μ F \pm 10%, 16V X7R ceramic capacitors (0603) Taiyo Yuden EMK107BJ154KA TDK C1608X7R1E154K
C16	1	10 μ F \pm 20%, 25V X5R ceramic capacitor (1210) Taiyo Yuden TMK325BJ106MM TDK C3225X5R1E106M
C17	1	10nF \pm 10%, 50V X7R ceramic capacitor (0603) Murata GRM188R71H103K TDK C1608X7R1H103K
C18, C19	2	22 μ F \pm 10%, 25V X5R ceramic capacitors (1210) Murata GRM32ER61E226K

MAX17113 Evaluation Kit

Evaluates: MAX17113

Component List (continued)

DESIGNATION	QTY	DESCRIPTION
C20	1	330pF ±10%, 50V X7R ceramic capacitor (0603) Murata GRM188R71H331K TDK C1608X7R1H331K
C21	1	2200pF ±10%, 50V X7R ceramic capacitor (0603) Murata GRM188R71H222K TDK C1608X7R1H222K
C26	1	1µF ±10%, 50V X7R ceramic capacitor (1206) Murata GRM31MR71H105KA TDK C3216X7R1H105K
C27–C31	0	Not installed, capacitors (0603)
C32	0	Not installed, capacitor (1210)
D1, D2	2	3A, 30V Schottky diodes (M-Flat) Toshiba CMS02(TE12L,Q)
D3, D4, D5	3	200mA, 100V dual ultra-fast diodes (SOT23) Fairchild MMBD4148SE (Top Mark: D4) Central Semi CMPD1001S Lead Free (Top Mark: L21)
D6	1	200mA, 100V single ultra-fast diode (SOT23) Fairchild MMBD4148 (Top Mark: 5H) Central Semi CMPD1001 Lead Free (Top Mark: L20)

DESIGNATION	QTY	DESCRIPTION
EN1, EN2, MODE, REF, VL	5	Test points
JU1, JU3, JU4, JU5, JU8	5	2-pin headers
JU2, JU6, JU7	3	3-pin headers
L1	1	10µH, 3A inductor (4mm height) Würth 744066100 Sumida CDRHD38
L2	1	Low-profile 4.7µH, 3A inductor (2mm height) Würth 7440700047 TOKO FDV0620-4R7M
R1	1	150kΩ ±1% resistor (0603)
R2	1	23.7kΩ ±1% resistor (0603)
R3	1	158kΩ ±1% resistor (0603)
R4, R17	2	13.3kΩ ±1% resistors (0603)
R5	1	82.5kΩ ±1% resistor (0603)
R6	1	33.2kΩ ±1% resistor (0603)
R7	1	2.2kΩ ±1% resistor (0603)
R8, R14	2	100kΩ ±5% resistors (0603)
R15	1	1kΩ ±5% resistor (0603)
R16	1	357kΩ ±1% resistor (0603)
R18	0	Not installed, resistor (0603)
R19	1	20kΩ ±1% resistor (0603)
R20	1	0Ω ±5% resistor (0603)
U1	1	Low-cost TFT-LCD power supply (40 TQFN-EP*) Maxim MAX17113ETL+
—	1	PCB: MAX17113 EVALUATION KIT+

*EP = Exposed pad.

MAX17113 Evaluation Kit

Component Suppliers

SUPPLIER	PHONE	WEBSITE
Central Semiconductor Corp.	631-435-1110	www.centralsemi.com
Fairchild Semiconductor	888-522-5372	www.fairchildsemi.com
Murata Electronics North America, Inc.	770-436-1300	www.murata-northamerica.com
Sumida Corp.	847-545-6700	www.sumida.com
Taiyo Yuden	800-348-2496	www.t-yuden.com
TDK Corp.	847-390-4373	www.component.tdk.com
Toshiba America Electronic Components, Inc.	949-623-2900	www.toshiba.com/taec
Würth Elektronik GmbH & Co. KG	201-785-8800	www.we-online.com

Note: Indicate that you are using the MAX17113 when contacting these component suppliers.

Table 1. Default Jumper Settings

JUMPER	SHUNT POSITION
JU1	Installed on one pin only
JU2	2-3
JU3	Installed
JU4	Installed
JU5	Installed
JU6	1-2
JU7	2-3
JU8	Installed on one pin only

Quick Start

Recommended Equipment

- +10.8V to +13.2V DC power supply
- Digital multimeters (DMMs)

Procedure

The MAX17113 EV kit is fully assembled and tested. Follow the steps below to verify board operation.

Caution: Do not turn on the power supply until all connections are completed.

- 1) Preset the power supply to +12V and disable the output.
- 2) Connect the positive terminal of the power supply to the VIN pad. Connect the negative terminal of the power supply to the PGND pad closest to VIN.
- 3) Verify that the jumpers follow the default settings in Table 1.
- 4) Turn on the power supply.
- 5) Verify that the step-up switching regulator output (AVDD) is approximately +16V.

6) Verify that the step-down switching regulator output (OUT) is approximately +3.3V.

7) Verify that the gate-on supply (VGON) is approximately +35V.

8) Verify that the gate-off supply (VGOFF) is approximately -6V.

Detailed Description of Hardware

The MAX17113 EV kit contains a step-down switching regulator, a step-up switching regulator, a positive dual-stage charge pump, a negative single-stage charge pump, a dual-mode logic-controlled high-voltage switch control block, and an adjustable-timing power-good output. Although the MAX17113 IC can operate from input voltages between +8V and +16.5V, the EV kit is optimized for LCD TV panel and LCD monitor applications running directly from +12V supplies.

Output Voltage Selection

Step-Down Regulator Output-Voltage Selection (OUT)

In the default fixed-mode configuration (FB2 pulled to AGND by R19), the step-down regulator provides a +3.3V output (OUT). In adjustable mode, the output voltage (1.5V to 5V) of the step-down regulator is set by connecting a resistive voltage-divider from the output (OUT) to AGND with the center tap connected to FB2. Calculate R18 with the following equation:

$$R18 = R19 \times \left(\frac{V_{OUT}}{V_{FB2}} - 1 \right)$$

where VFB2, the step-down regulator's feedback set point, is 1.25V.

MAX17113 Evaluation Kit

Step-Up Regulator Output-Voltage Selection (AVDD)

The output voltage (VIN to 18V) of the main step-up regulator is set by connecting a resistive voltage-divider from the output (AVDD) to AGND with the center tap connected to FB1. Calculate R3 with the following equation:

$$R3 = R4 \times \left(\frac{V_{AVDD}}{V_{FB1}} - 1 \right)$$

where V_{FB1} , the step-up regulator's feedback set point, is 1.25V.

Positive Charge-Pump Output Output-Voltage Selection (VGON)

The positive charge-pump output (VGON) is set to +35V by voltage-divider resistors R16 and R17. To set VGON to other voltages (up to approximately 3 x AVDD, 44V max), select different divider resistors. For voltages below 2 x AVDD, change the shunt position of JU7 to 1-2. Refer to the *Design Procedure, Charge-Pump Regulators, Output-Voltage Selection* section in the MAX17113 IC data sheet for instructions on selecting resistors R16 and R17.

Negative Charge-Pump Output Output-Voltage Selection (VGOFF)

The negative charge-pump output (VGOFF) is set to -6V by voltage-divider resistors R1 and R2. To set VGOFF to other voltages (0V to -VIN), select different divider

resistors. For VGOFF less than -16V, select C15 with a higher voltage rating. Refer to the *Design Procedure, Charge-Pump Regulators, Output-Voltage Selection* section in the MAX17113 IC data sheet for instructions on selecting resistors R1 and R2.

Jumper Selection

Several jumper settings in the following tables illustrate features of the MAX17113 EV kit.

Frequency Select Input (FSEL)

The MAX17113 EV kit features jumper JU1 to control the switching regulator's operating frequency. Connect FSEL to AGND for 450kHz operation. Connect FSEL to VL for 600kHz operation. See Table 2 for jumper JU1 functions.

High-Voltage Switch Mode (MODE)

The MAX17113 EV kit features an option to select the operating mode (delay or no delay) for the high-voltage switches. On the rising edge of the CTL pin, GON connects to SRC. On CTL's falling edge, GON may connect immediately to DRN (no delay), or to DRN after a delay set by C9. Refer to the *High-Voltage Switch Control* section in the MAX17113 IC data sheet for a more detailed description of the two modes of operation. Jumper JU2 selects the high-voltage switch operating mode for the MAX17113. Table 3 lists the selectable JU2 jumper options.

Table 2. Jumper JU1 Functions

SHUNT POSITION	FSEL PIN	OPERATION OF FREQUENCY (kHz)
Installed	Connected to VL	600
Not installed*	Connected to AGND (through internal 1MΩ pulldown resistor)	450

*Default position.

Table 3. Jumper JU2 Functions

SHUNT POSITION	MODE PIN	HIGH-VOLTAGE SWITCH MODE
1-2	Connected to C9	Delay set by C9
2-3*	Connected to VL	No delay
Not installed	Unconnected	Not allowed

*Default position.

Table 4. Jumper JU3 and JU4 Functions

SHUNT POSITION		STEP-DOWN AND NEGATIVE CHARGE-PUMP REGULATOR	STEP-UP AND POSITIVE CHARGE-PUMP REGULATOR
JU3	JU4		
Installed*	Installed*	Enabled	Enabled
Installed	Not installed	Enabled	Disabled
Not installed	X	Disabled	Disabled

*Default position.

X = Don't care.

MAX17113 Evaluation Kit

Evaluates: MAX17113

Enable-Control Inputs (EN1, EN2)

The MAX17113 EV kit features jumpers JU3 and JU4 to control the two switching regulators and the two charge-pump regulators' enable inputs. Jumper JU3 controls the step-down and negative charge-pump regulator enable input (EN1). Jumper JU4 controls the step-up and positive charge-pump regulator enable input (EN2). EN2 is inactive when EN1 is low. See Table 4 for jumper JU3 and JU4 functions.

High-Voltage Switch-Control Input (CTL)

Jumper JU5 configures the setting to control the high-voltage switch-control pin (CTL) of the MAX17113 IC. The switch between the SRC and GON pins and the switch between the GON and DRN pins can also be controlled by an external logic controller connected to the CTL pad. See Table 5 for switch states and refer to the *High-Voltage Switch Control* section in the MAX17113 IC data sheet for further information about the high-voltage switches connected to the GON pin.

Table 5. Jumper JU5 Functions

SHUNT POSITION	CTL PIN	MAX17113 HIGH-VOLTAGE SWITCH CONFIGURATION
Installed*	Connected to VL	GON connected to SRC
Not installed	Connected to AGND (through resistor R14)	GON connected to DRN
Not Installed (external logic controller connected to CTL pad)	External logic controller	GON pin connected to SRC pin (CTL driven high)
		GON pin connected to DRN pin (CTL driven low)

*Default position.

VGON Discharge Path

The MAX17113 EV kit features a method to configure the VGON discharge path using resistor R15 and jumper JU6. When CTL is low, GON is connected to DRN, allowing VGON to discharge through resistor R15. JU6 selects the discharge path by connecting R15 to AVDD (through diode D6) or to PGND. Table 6 lists the selectable JU6 jumper options.

Positive Charge-Pump Stage Selection

Jumper JU7 is provided to select between a positive dual-stage charge pump and a positive single-stage charge pump. Table 7 lists the selectable JU7 jumper options.

High-Voltage Switch-Control Block Output (GON)

Jumper JU8 is provided to connect or disconnect a bypass capacitor to the high-voltage switch-control block output GON terminal. Table 8 lists the selectable JU8 jumper options.

Table 6. Jumper JU6 Functions

SHUNT POSITION	DRN PIN	VGON DISCHARGED TOWARDS
1-2*	Connected to AVDD (through resistor R15 and diode D6)	AVDD
2-3	Connected to PGND (through resistor R15)	PGND

*Default position.

Table 7. Jumper JU7 Functions

SHUNT POSITION	POSITIVE CHARGE PUMP
1-2	Single-stage charge pump
2-3*	Dual-stage charge pump

*Default position.

Table 8. Jumper JU8 Functions

SHUNT POSITION	C21 BYPASS CAPACITOR
Installed	Enabled
Not installed*	Disabled

*Default position.

MAX17113 Evaluation Kit

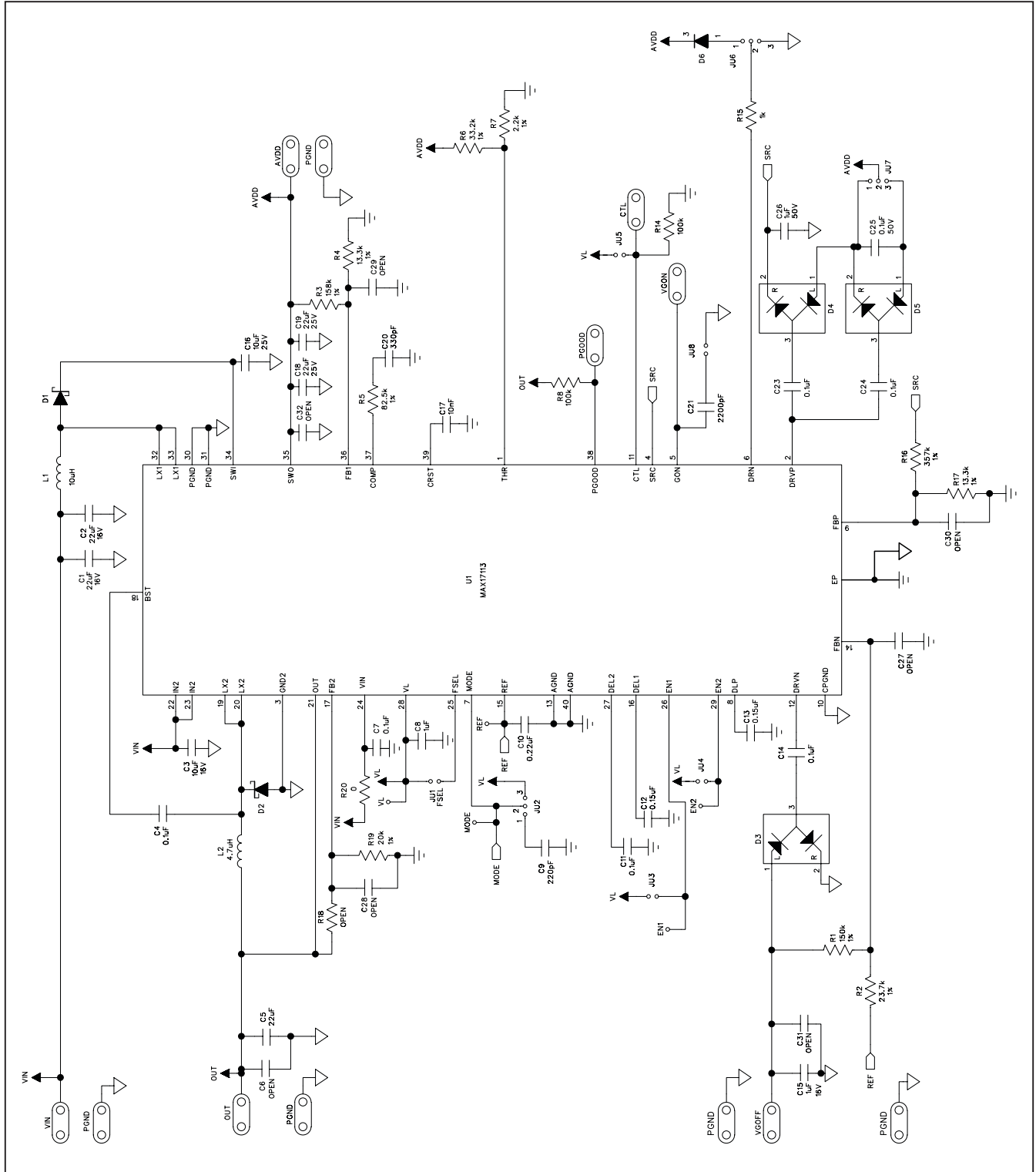

Figure 1. MAX17113 EV Kit Schematic

MAX17113 Evaluation Kit

Evaluates: MAX17113

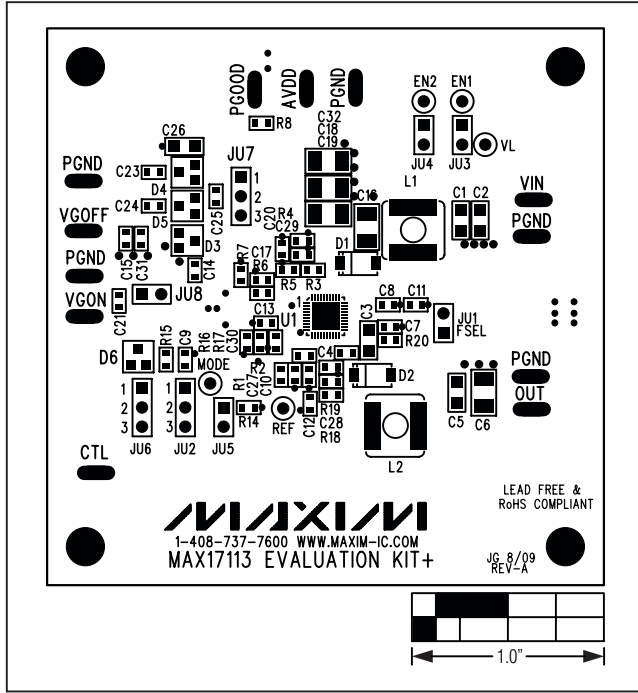

Figure 2. MAX17113 EV Kit Component Placement Guide—Component Side

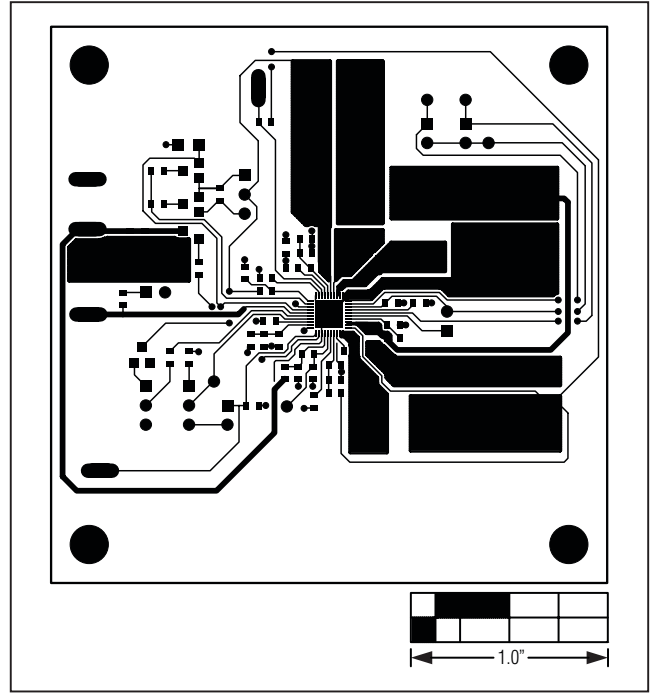

Figure 3. MAX17113 EV Kit PCB Layout—Component Side

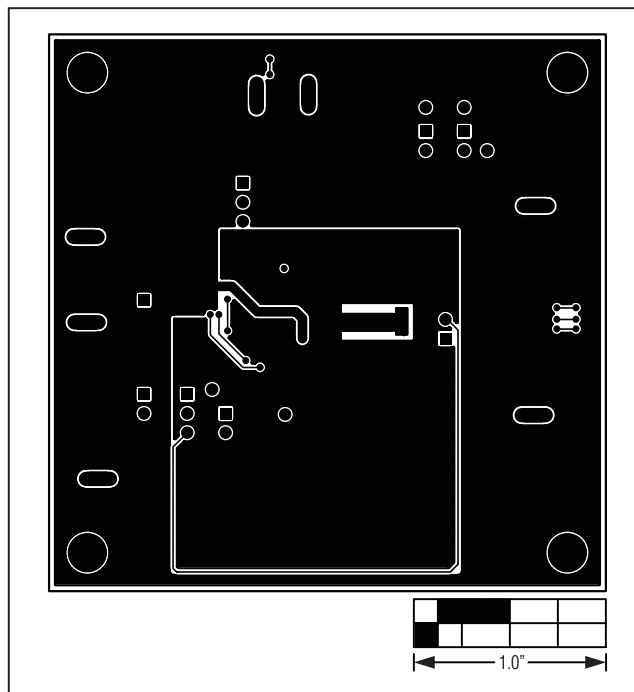

Figure 4. MAX17113 EV Kit PCB Layout—Solder Side

Maxim cannot assume responsibility for use of any circuitry other than circuitry entirely embodied in a Maxim product. No circuit patent licenses are implied. Maxim reserves the right to change the circuitry and specifications without notice at any time.

Maxim Integrated Products, 120 San Gabriel Drive, Sunnyvale, CA 94086 408-737-7600 _____ 7

Компания «Океан Электроники» предлагает заключение долгосрочных отношений при поставках импортных электронных компонентов на взаимовыгодных условиях!

Наши преимущества:

- Поставка оригинальных импортных электронных компонентов напрямую с производств Америки, Европы и Азии, а так же с крупнейших складов мира;
- Широкая линейка поставок активных и пассивных импортных электронных компонентов (более 30 млн. наименований);
- Поставка сложных, дефицитных, либо снятых с производства позиций;
- Оперативные сроки поставки под заказ (от 5 рабочих дней);
- Экспресс доставка в любую точку России;
- Помощь Конструкторского Отдела и консультации квалифицированных инженеров;
- Техническая поддержка проекта, помощь в подборе аналогов, поставка прототипов;
- Поставка электронных компонентов под контролем ВП;
- Система менеджмента качества сертифицирована по Международному стандарту ISO 9001;
- При необходимости вся продукция военного и аэрокосмического назначения проходит испытания и сертификацию в лаборатории (по согласованию с заказчиком);
- Поставка специализированных компонентов военного и аэрокосмического уровня качества (Xilinx, Altera, Analog Devices, Intersil, Interpoint, Microsemi, Actel, Aeroflex, Peregrine, VPT, Syfer, Eurofarad, Texas Instruments, MS Kennedy, Miteq, Cobham, E2V, MA-COM, Hittite, Mini-Circuits, General Dynamics и др.);

Компания «Океан Электроники» является официальным дистрибьютором и эксклюзивным представителем в России одного из крупнейших производителей разъемов военного и аэрокосмического назначения «JONHON», а так же официальным дистрибьютором и эксклюзивным представителем в России производителя высокотехнологичных и надежных решений для передачи СВЧ сигналов «FORSTAR».



JONHON

«JONHON» (основан в 1970 г.)

Разъемы специального, военного и аэрокосмического назначения:

(Применяются в военной, авиационной, аэрокосмической, морской, железнодорожной, горно- и нефтедобывающей отраслях промышленности)

«FORSTAR» (основан в 1998 г.)

ВЧ соединители, коаксиальные кабели, кабельные сборки и микроволновые компоненты:

(Применяются в телекоммуникациях гражданского и специального назначения, в средствах связи, РЛС, а так же военной, авиационной и аэрокосмической отраслях промышленности).



Телефон: 8 (812) 309-75-97 (многоканальный)

Факс: 8 (812) 320-03-32

Электронная почта: ocean@oceanchips.ru

Web: <http://oceanchips.ru/>

Адрес: 198099, г. Санкт-Петербург, ул. Калинина, д. 2, корп. 4, лит. А