

### Features

- Surface Mount Packages (SOT-23, SC70 3LD, SOD-323, SC-79)
- High Q at Low Voltages
- High Capacitance Ratio at Low Voltages
- SPC Process for Superior C-V Repeatability
- Available as Single and Common Cathode Pairs
- Tape and Reel Packaging
- Designed for Commercial Wireless Applications
- RoHS\* Compliant and 260°C Reflow Compatible

### Description

The MAVR-000200 series are ion-implanted, hyperabrupt junction, silicon tuning varactors in SOT-23, SC70 3LD, SOD-323 and SC-79 surface mount packages. This series of varactors is designed for high Q and low voltage operation. Each varactor type has a typical Q greater than 400 at -2 V. These diodes are offered with 100% matte Sn plating.

The MAVR-000200 series tuning varactors are ideally suited for wide band tuning and low phase noise applications where the supply voltage is limited to 5 volts or less. These varactors have been specifically designed for use in wireless communications up to the 2.4 GHz band. Applications include VCOs and voltage tuned filters.

### Configurations

#### Top View (SOT-23, SC70 3LD)

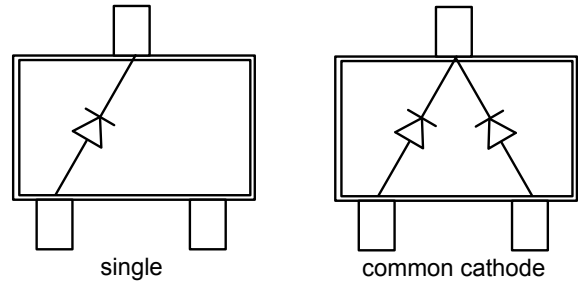

#### Top View (SOD-323, SC-79)

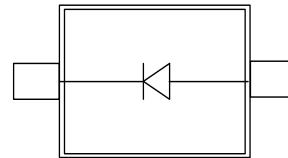

### Typical Device Selection by Frequency

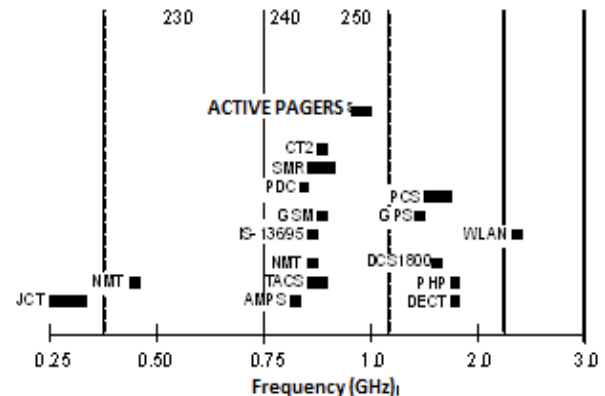

\*Restrictions on Hazardous Substances, European Union Directive 2011/65/EU.

### Electrical Specifications @ $T_A = +25\text{ }^\circ\text{C}$

Breakdown Voltage @  $I_R = 10\text{ }\mu\text{A}$ ,  $V_b = 12\text{ V}$  Minimum

Reverse Leakage Current @  $V_R = 10\text{ V}$ ,  $I_R = 100\text{ nA}$  Maximum

Base Part Number	Capacitance ( $C_T$ ) <sup>1</sup> (pF)			Capacitance Ratio	Q Factor	
	f = 1 MHz, $V_R = 2.0\text{ V}$			f = 1 MHz $V_R = 4.0\text{ V}$	$C_{T0.5} / C_{T4.0}$	f = 50 MHz $V_R = 2.0\text{ V}$
	Min.	Nom.	Max.	Max.	Typ.	Typ.
MAVR-000230-XXXXXX	4.5	5.0	6.0	3.1	3.5	400
MAVR-000240-XXXXXX	3.0	3.5	4.2	2.3	3.5	450
MAVR-000250-XXXXXX	2.3	2.7	3.5	1.8	3.5	450

1. Capacitance @ 1 MHz

### Absolute Maximum Ratings<sup>2,3</sup>

@  $T_A = +25\text{ }^\circ\text{C}$  (Unless Otherwise Noted)

Parameter	Absolute Maximum
Reverse Voltage	12 V
Forward Current	50 mA
Total Power Dissipation	250 mW
Operating Temperature	-55°C to +125°C
Storage Temperature	-55°C to +125°C

- Exceeding any one or combination of these limits may cause permanent damage to this device.
- MACOM does not recommend sustained operation near these survivability limits.

### Handling Procedures

Please observe the following precautions to avoid damage:

### Static Sensitivity

Silicon Integrated Circuits are sensitive to electrostatic discharge (ESD) and can be damaged by static electricity. Proper ESD control techniques should be used when handling these devices.

### Part Number Designations

Ordering Part Number	Package Style	Diode Configuration	Diode Marking
MAVR-000230-0287AT	SOT-23	Single	V5J
MAVR-000230-0287FT	SOT-23	Common Cathode	V5K
MAVR-000230-11410T	SOD-323	Single	5J
MAVR-000240-0287AT	SOT-23	Single	V5L
MAVR-000240-11410T	SOD-323	Single	5L
MAVR-000240-1146FT	SC-70	Common Cathode	5M
MAVR-000250-0287AT	SOT-23	Single	V5N
MAVR-000250-0287FT	SOT-23	Common Cathode	V5P
MAVR-000250-11410T	SOD-323	Single	5N
MAVR-000250-1146FT	SC-70	Common Cathode	5P
MAVR-000250-12790T	SC-79	Single	No Marking

### Spice Model

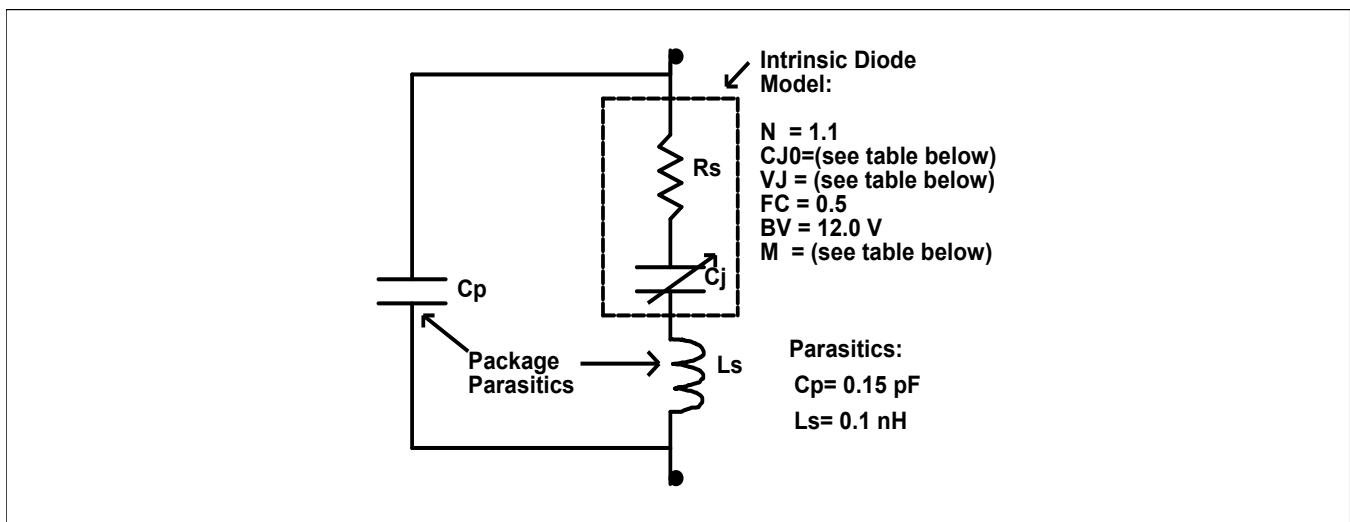

Base Part No.	CJ0 (pF)	VJ (V)	M
MAVR-000230	12.0	4.085	2.228
MAVR-000240	8.16	4.930	2.520
MAVR-000250	6.19	4.774	2.458

## Typical Performance Curves

NOMINAL Q at 50 MHz vs REVERSE VOLTAGE

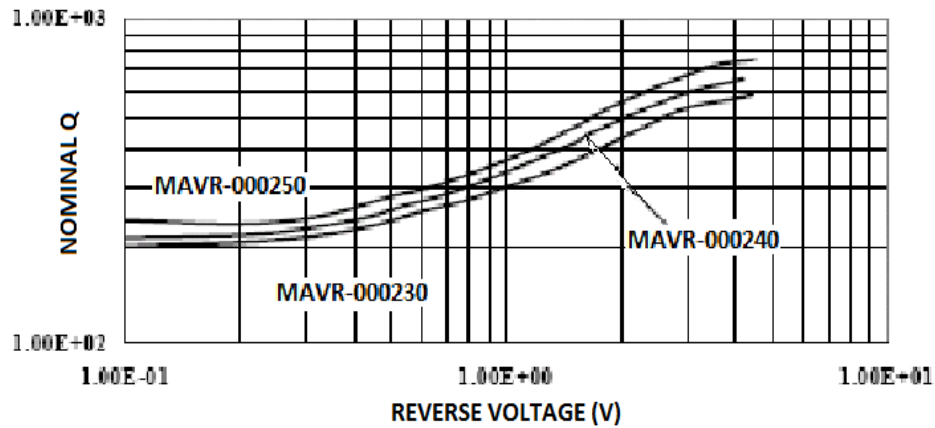

TOTAL CAPACITANCE VS REVERSE VOLTAGE at 1MHz

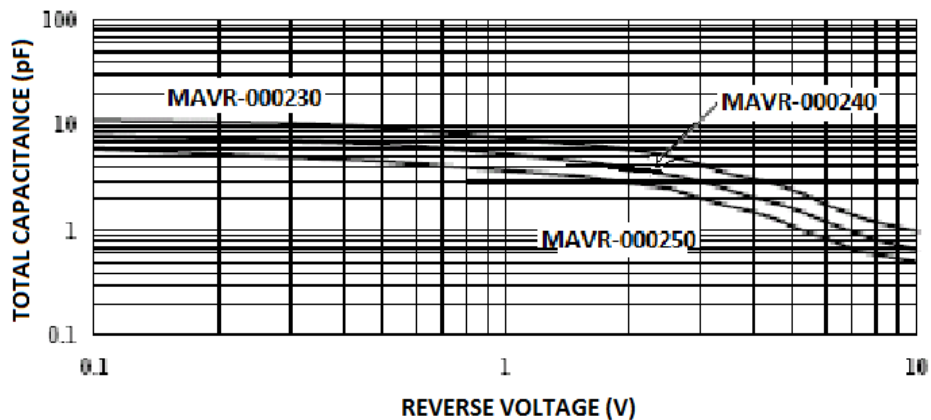

NOMINAL CHANGE in CAPACITANCE with TEMPERATURE

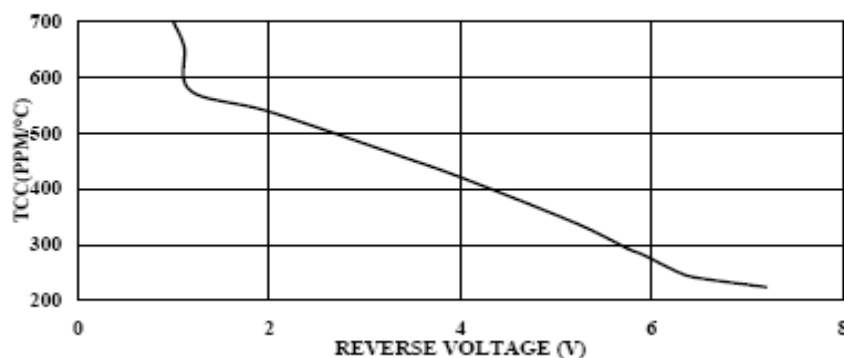

### Case Styles

#### SOT-23 (Case Style 287)

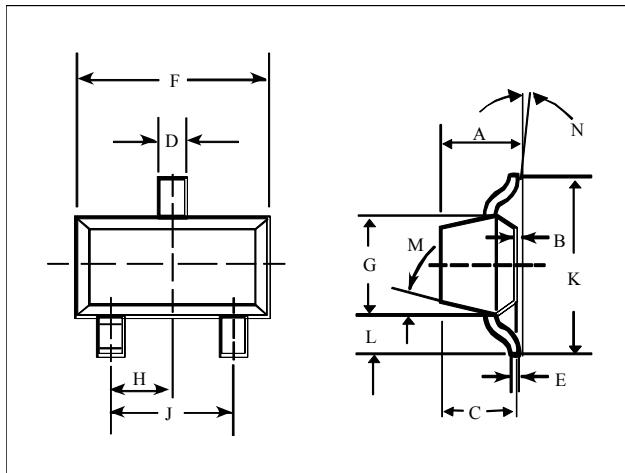

Dim.	INCHES		MILLIMETERS	
	Min.	Max.	Min.	Max.
A	—	0.048	—	1.22
B	—	0.008	—	0.20
C	—	0.040	—	1.00
D	0.013	0.020	0.35	0.50
E	0.003	0.006	0.08	0.15
F	0.110	0.119	2.80	3.00
G	0.047	0.056	1.20	1.40
H	0.037 typical		0.95 typical	
J	0.075 typical		1.90 typical	
K	—	0.103	—	2.60
L	—	0.024	—	0.60
<b>Dim.</b>	<b>GRADIENT</b>			
M	10° max. <sup>4</sup>			
N	2° .. .30°			

4. Applicable on all sides

#### SC-70, 3 Lead (Case Style 1146)

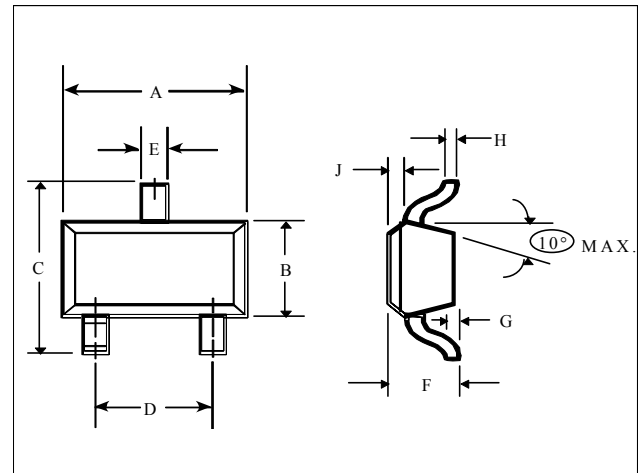

Dim.	INCHES		MILLIMETERS	
	Min.	Max.	Min.	Max.
A	0.071	0.087	1.80	2.21
B	0.045	0.053	1.14	1.35
C	0.071	0.094	1.80	2.39
D	0.047	0.057	1.19	1.45
E	0.010	0.016	0.25	0.41
F	0.031	0.039	0.79	1.00
G	0.000	0.004	0.00	0.10
H	0.004	0.007	0.10	0.18
J	0.004	0.010	0.10	0.25

### Case Styles

#### SOD-323 (Case Style 1141)

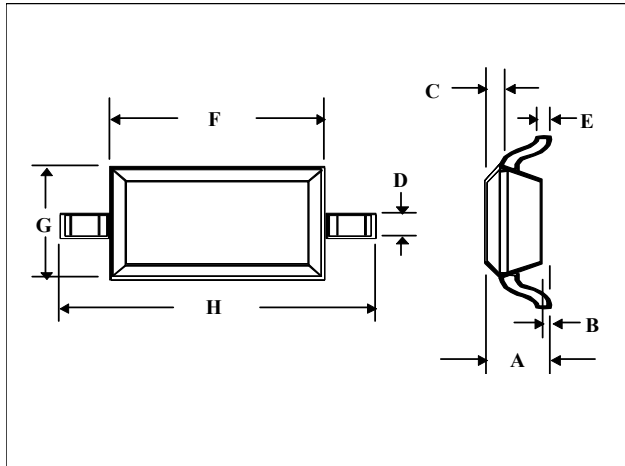

Dim.	INCHES		MILLIMETERS	
	Min.	Max.	Min.	Max.
A	—	0.043	—	1.1
B	—	0.004	—	0.1
C	—	0.008	—	0.2
D	0.010	0.016	0.25	0.41
E	0.003	0.006	0.07	0.15
F	0.063	0.075	1.6	1.9
G	0.045	0.057	1.14	1.45
H	0.091	0.106	2.3	2.7

#### SC-79 (Case Style 1279)

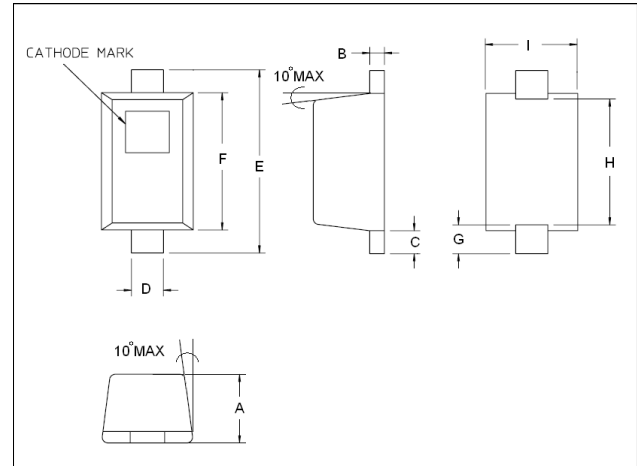

Dim.	INCHES		MILLIMETERS	
	Min.	Max.	Min.	Max.
A	.0197	.0276	0.50	0.70
B	0.003	0.008	0.07	0.20
C	0.006	0.010	0.15	0.25
D	0.010	0.014	0.25	0.35
E	0.059	0.067	1.50	1.70
F	0.043	0.051	1.09	1.30
G	.0098 nominal		0.250 nominal	
H	.0433 nominal		1.10 nominal	
I	.027	.035	0.68	0.89

### Mounting Information

The illustration indicates the recommended mounting pad configuration for the SC-79, SC70 3LD, SOT-23 and SOD-323 packages. Solder paste containing flux should be screened onto the pads to a thickness of 0.005 - 0.007 inches. The plastic package is placed in position, firmly adhering to the solder paste.

Permanent attachment is performed by a reflow soldering procedure during which the tab temperature does not exceed +275°C and the body temperature does not exceed +260°C.

Please refer to Application Note M538 for surface mounting instructions.

#### SOT-23 (Case Style 287)

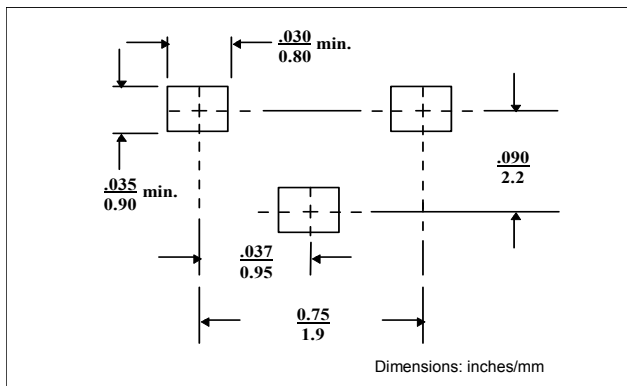

#### SC-70, 3 Lead (Case Style 1146)

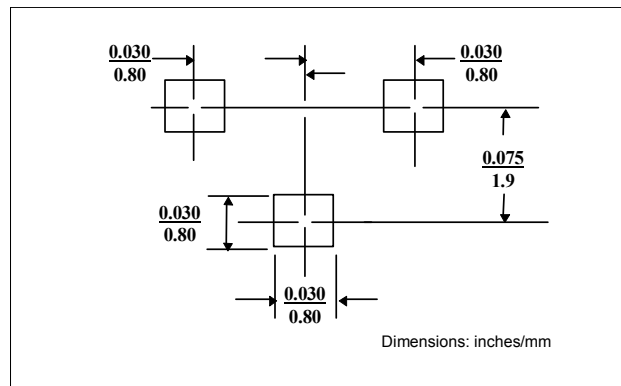

#### SOD-323 (Case Style 1141)

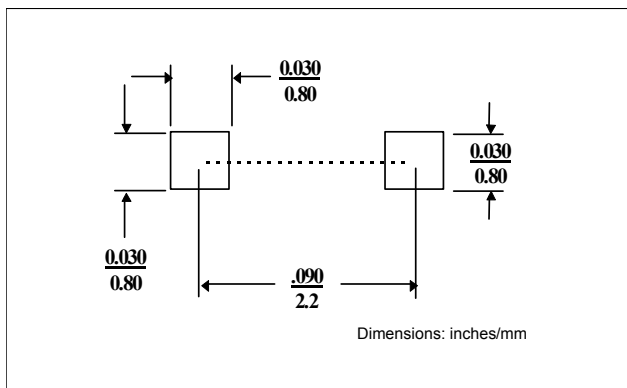

#### SC-79 (Case Style 1279)

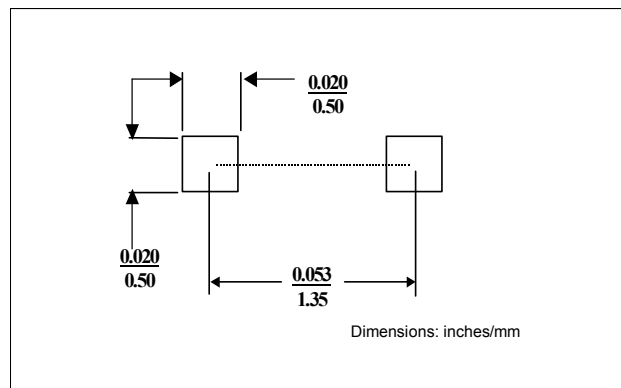

M/A-COM Technology Solutions Inc. All rights reserved.

Information in this document is provided in connection with M/A-COM Technology Solutions Inc ("MACOM") products. These materials are provided by MACOM as a service to its customers and may be used for informational purposes only. Except as provided in MACOM's Terms and Conditions of Sale for such products or in any separate agreement related to this document, MACOM assumes no liability whatsoever. MACOM assumes no responsibility for errors or omissions in these materials. MACOM may make changes to specifications and product descriptions at any time, without notice. MACOM makes no commitment to update the information and shall have no responsibility whatsoever for conflicts or incompatibilities arising from future changes to its specifications and product descriptions. No license, express or implied, by estoppel or otherwise, to any intellectual property rights is granted by this document.

THESE MATERIALS ARE PROVIDED "AS IS" WITHOUT WARRANTY OF ANY KIND, EITHER EXPRESS OR IMPLIED, RELATING TO SALE AND/OR USE OF MACOM PRODUCTS INCLUDING LIABILITY OR WARRANTIES RELATING TO FITNESS FOR A PARTICULAR PURPOSE, CONSEQUENTIAL OR INCIDENTAL DAMAGES, MERCHANTABILITY, OR INFRINGEMENT OF ANY PATENT, COPYRIGHT OR OTHER INTELLECTUAL PROPERTY RIGHT. MACOM FURTHER DOES NOT WARRANT THE ACCURACY OR COMPLETENESS OF THE INFORMATION, TEXT, GRAPHICS OR OTHER ITEMS CONTAINED WITHIN THESE MATERIALS. MACOM SHALL NOT BE LIABLE FOR ANY SPECIAL, INDIRECT, INCIDENTAL, OR CONSEQUENTIAL DAMAGES, INCLUDING WITHOUT LIMITATION, LOST REVENUES OR LOST PROFITS, WHICH MAY RESULT FROM THE USE OF THESE MATERIALS.

MACOM products are not intended for use in medical, lifesaving or life sustaining applications. MACOM customers using or selling MACOM products for use in such applications do so at their own risk and agree to fully indemnify MACOM for any damages resulting from such improper use or sale.



Компания «Океан Электроники» предлагает заключение долгосрочных отношений при поставках импортных электронных компонентов на взаимовыгодных условиях!

Наши преимущества:

- Поставка оригинальных импортных электронных компонентов напрямую с производств Америки, Европы и Азии, а так же с крупнейших складов мира;
- Широкая линейка поставок активных и пассивных импортных электронных компонентов (более 30 млн. наименований);
- Поставка сложных, дефицитных, либо снятых с производства позиций;
- Оперативные сроки поставки под заказ (от 5 рабочих дней);
- Экспресс доставка в любую точку России;
- Помощь Конструкторского Отдела и консультации квалифицированных инженеров;
- Техническая поддержка проекта, помощь в подборе аналогов, поставка прототипов;
- Поставка электронных компонентов под контролем ВП;
- Система менеджмента качества сертифицирована по Международному стандарту ISO 9001;
- При необходимости вся продукция военного и аэрокосмического назначения проходит испытания и сертификацию в лаборатории (по согласованию с заказчиком);
- Поставка специализированных компонентов военного и аэрокосмического уровня качества (Xilinx, Altera, Analog Devices, Intersil, Interpoint, Microsemi, Actel, Aeroflex, Peregrine, VPT, Syfer, Eurofarad, Texas Instruments, MS Kennedy, Miteq, Cobham, E2V, MA-COM, Hittite, Mini-Circuits, General Dynamics и др.);

Компания «Океан Электроники» является официальным дистрибьютором и эксклюзивным представителем в России одного из крупнейших производителей разъемов военного и аэрокосмического назначения «**JONHON**», а так же официальным дистрибьютором и эксклюзивным представителем в России производителя высокотехнологичных и надежных решений для передачи СВЧ сигналов «**FORSTAR**».



## JONHON

«**JONHON**» (основан в 1970 г.)

Разъемы специального, военного и аэрокосмического назначения:

(Применяются в военной, авиационной, аэрокосмической, морской, железнодорожной, горно- и нефтедобывающей отраслях промышленности)

«**FORSTAR**» (основан в 1998 г.)

ВЧ соединители, коаксиальные кабели,  
кабельные сборки и микроволновые компоненты:

(Применяются в телекоммуникациях гражданского и специального назначения, в средствах связи, РЛС, а так же военной, авиационной и аэрокосмической отраслях промышленности).



Телефон: 8 (812) 309-75-97 (многоканальный)

Факс: 8 (812) 320-03-32

Электронная почта: [ocean@oceanchips.ru](mailto:ocean@oceanchips.ru)

Web: <http://oceanchips.ru/>

Адрес: 198099, г. Санкт-Петербург, ул. Калинина, д. 2, корп. 4, лит. А