



## QUAD/DUAL N-CANNEL MATCHED PAIR MOSFET ARRAY

### GENERAL DESCRIPTION

The ALD1106/ALD1116 are monolithic quad/dual N-channel enhancement mode matched MOSFET transistor arrays intended for a broad range of precision analog applications. The ALD1106/ALD1116 offer high input impedance and negative current temperature coefficient. The transistor pairs are matched for minimum offset voltage and differential thermal response, and they are designed for precision analog switching and amplifying applications in +2V to +12V systems where low input bias current, low input capacitance and fast switching speed are desired. These MOSFET devices feature very large (almost infinite) current gain in a low frequency, or near DC, operating environment. The ALD1106/ALD1116 are building blocks for differential amplifier input stages, transmission gates, and multiplexer applications, current sources and many precision analog circuits.

### FEATURES

- Low threshold voltage of 0.7V
- Low input capacitance
- Low Vos 2mV typical
- High input impedance -- 10<sup>14</sup>Ω typical
- Negative current (I<sub>DS</sub>) temperature coefficient
- Enhancement-mode (normally off)
- DC current gain 10<sup>9</sup>
- Low input and output leakage currents
- RoHS compliant

### ORDERING INFORMATION ("L" suffix denotes lead-free (RoHS))

Operating Temperature Range*		
0°C to +70°C	0°C to +70°C	-55°C to +125°C
8-Pin SOIC Package	8-Pin Plastic Dip Package	8-Pin CERDIP Package
ALD1116SAL	ALD1116PAL	ALD1116DA
14-Pin SOIC Package	14-Pin Plastic Dip Package	14-Pin CERDIP Package
ALD1106SBL	ALD1106PBL	ALD1106DB

\* Contact factory for leaded (non-RoHS) or high temperature versions.

### BLOCK DIAGRAM

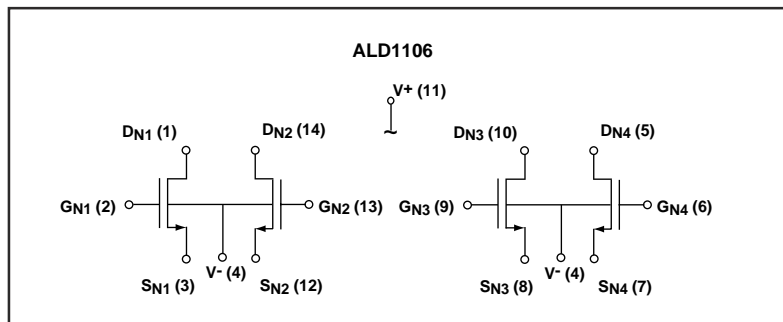

### APPLICATIONS

- Precision current mirrors
- Precision current sources
- Voltage choppers
- Differential amplifier input stage
- Voltage comparator
- Data converters
- Sample and Hold
- Analog signal processing

### PIN CONFIGURATION

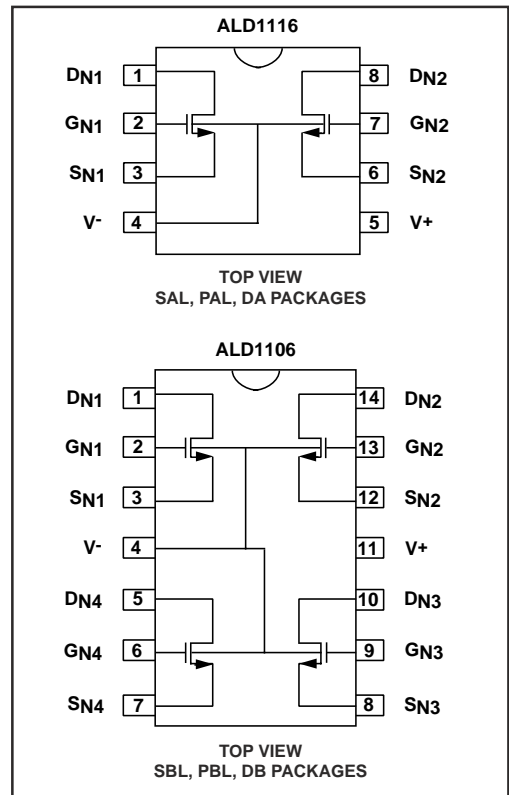

### BLOCK DIAGRAM

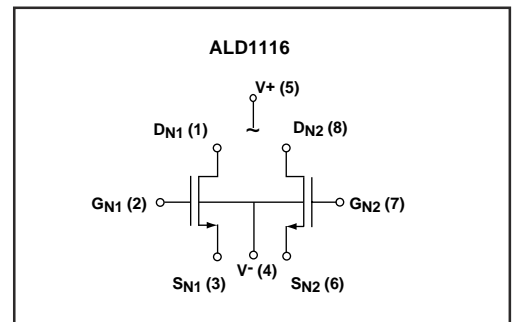

## ABSOLUTE MAXIMUM RATINGS

Drain-source voltage,  $V_{DS}$  \_\_\_\_\_ 10.6V  
 Gate-source voltage,  $V_{GS}$  \_\_\_\_\_ 10.6V  
 Power dissipation \_\_\_\_\_ 500mW  
 Operating temperature range SAL, PAL, SBL, PBL packages \_\_\_\_\_ 0°C to +70°C  
 DA, DB packages \_\_\_\_\_ -55°C to +125°C  
 Storage temperature range \_\_\_\_\_ -65°C to +150°C  
 Lead temperature, 10 seconds \_\_\_\_\_ +260°C  
 CAUTION: ESD Sensitive Device. Use static control procedures in ESD controlled environment.

## OPERATING ELECTRICAL CHARACTERISTICS

$T_A = 25^\circ\text{C}$  unless otherwise specified

Parameter	Symbol	ALD1106			ALD1116			Unit	Test Conditions
		Min	Typ	Max	Min	Typ	Max		
Gate Threshold Voltage	$V_T$	0.4	0.7	1.0	0.4	0.7	1.0	V	$I_{DS} = 1.0\mu\text{A}$ $V_{GS} = V_{DS}$
Offset Voltage $V_{GS1}-V_{GS2}$	$V_{OS}$		2	10		2	10	mV	$I_{DS} = 10\mu\text{A}$ $V_{GS} = V_{DS}$
Gate Threshold Temperature Drift <sup>2</sup>	$TC_{VT}$		-1.2			-1.2		mV/°C	
On Drain Current	$I_{DS(ON)}$	3.0	4.8		3.0	4.8		mA	$V_{GS} = V_{DS} = 5\text{V}$
Transconductance	$G_{IS}$	1.0	1.8		1.0	1.8		mmho	$V_{DS} = 5\text{V}$ $I_{DS} = 10\text{mA}$
Mismatch	$\Delta G_{IS}$		0.5			0.5		%	
Output Conductance	$G_{OS}$		200			200		$\mu\text{mho}$	$V_{DS} = 5\text{V}$ $I_{DS} = 10\text{mA}$
Drain Source On Resistance	$R_{DS(ON)}$		350	500		350	500	$\Omega$	$V_{DS} = 0.1\text{V}$ $V_{GS} = 5\text{V}$
Drain Source On Resistance Mismatch	$\Delta_{DS(ON)}$		0.5			0.5		%	$V_{DS} = 0.1\text{V}$ $V_{GS} = 5\text{V}$
Drain Source Breakdown Voltage	$BV_{DSS}$	12			12			V	$I_{DS} = 1.0\mu\text{A}$ $V_{GS} = 0\text{V}$
Off Drain Current <sup>1</sup>	$I_{DS(OFF)}$		10	400 4		10	400 4	pA nA	$V_{DS} = 12\text{V}$ $V_{GS} = 0\text{V}$ $T_A = 125^\circ\text{C}$
Gate Leakage Current	$I_{GSS}$		0.1	10 1		0.1	10 1	pA nA	$V_{DS} = 0\text{V}$ $V_{GS} = 12\text{V}$ $T_A = 125^\circ\text{C}$
Input Capacitance <sup>2</sup>	$C_{ISS}$		1	3		1	3	pF	

Notes: <sup>1</sup> Consists of junction leakage currents  
<sup>2</sup> Sample tested parameters

# TYPICAL PERFORMANCE CHARACTERISTICS

## OUTPUT CHARACTERISTICS

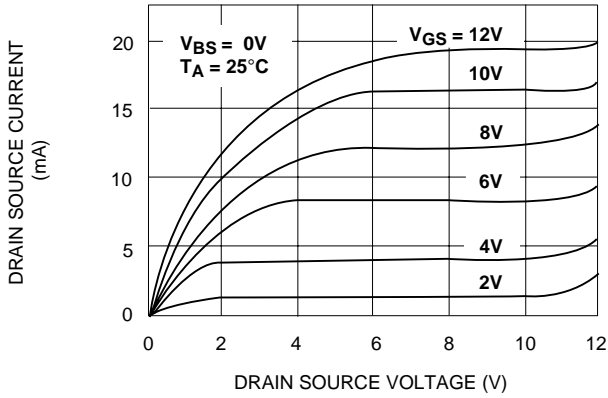

## LOW VOLTAGE OUTPUT CHARACTERISTICS

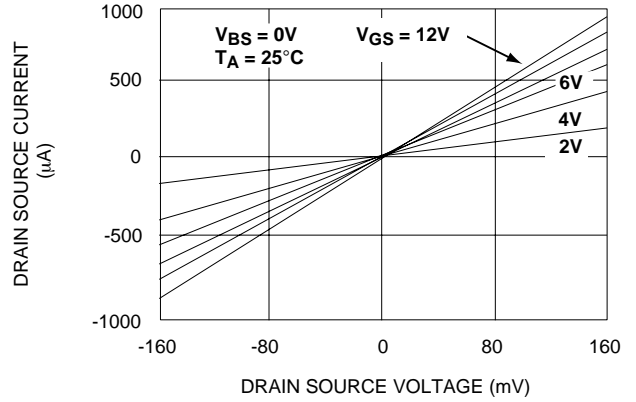

## FORWARD TRANSCONDUCTANCE vs. DRAIN SOURCE VOLTAGE

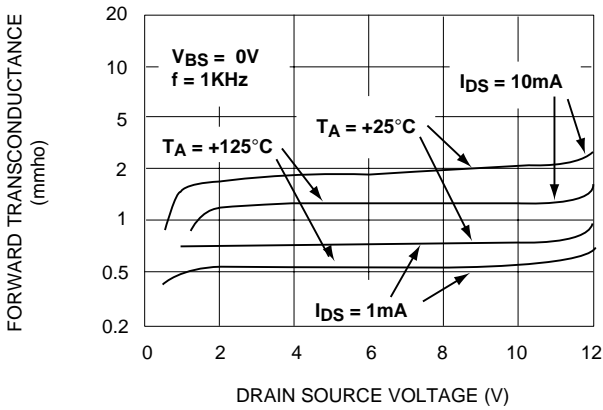

## TRANSFER CHARACTERISTIC WITH SUBSTRATE BIAS

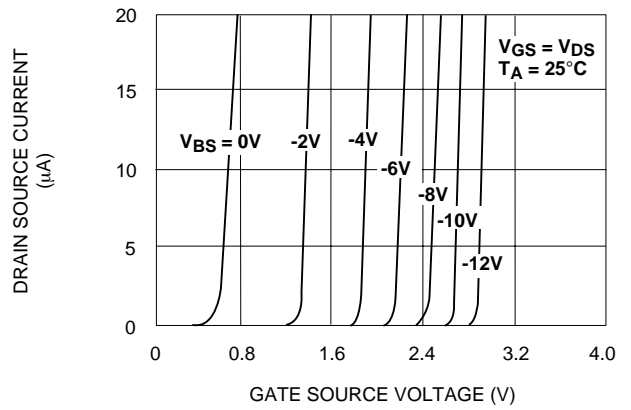

## DRAIN SOURCE ON RESISTANCE $R_{DS(ON)}$ vs. GATE SOURCE VOLTAGE

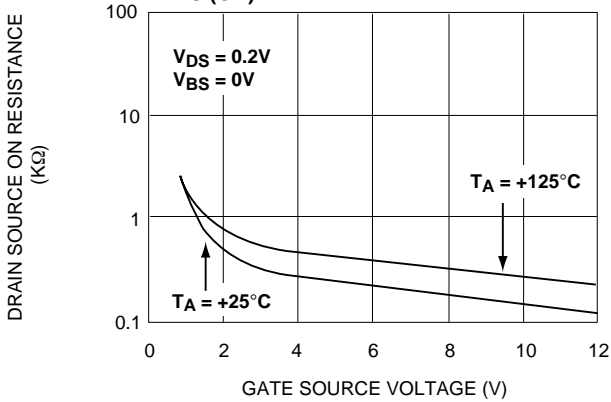

## OFF DRAIN CURRENT vs. AMBIENT TEMPERATURE

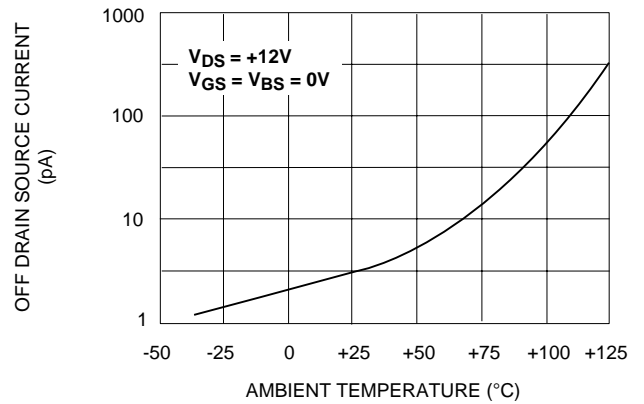

# TYPICAL APPLICATIONS

## CURRENT SOURCE MIRROR

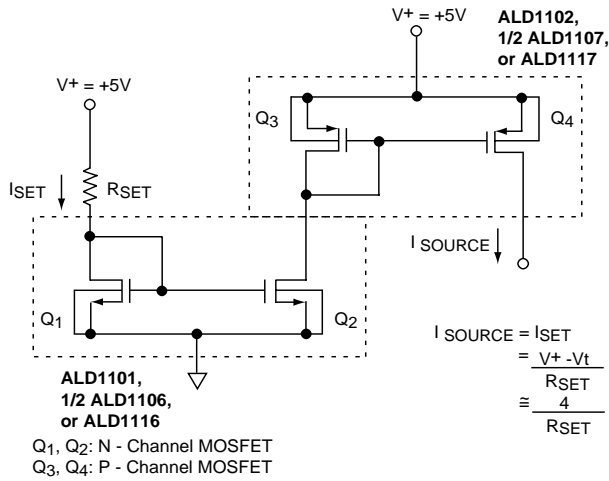

## CURRENT SOURCE WITH GATE CONTROL

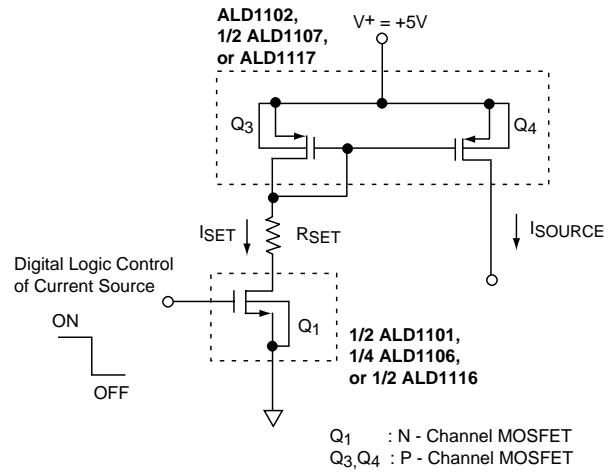

## DIFFERENTIAL AMPLIFIER

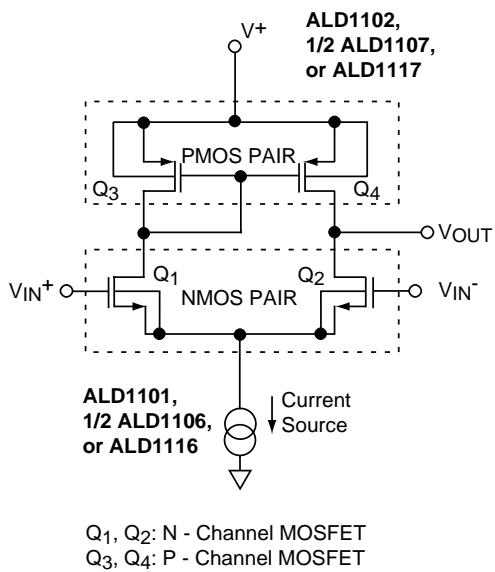

## CURRENT SOURCE MULTIPLICATION

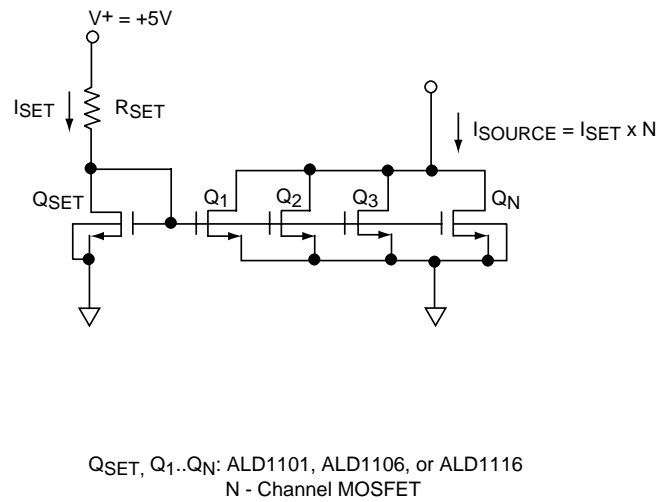

# TYPICAL APPLICATIONS (cont.)

## BASIC CURRENT SOURCES

### N- CHANNEL CURRENT SOURCE

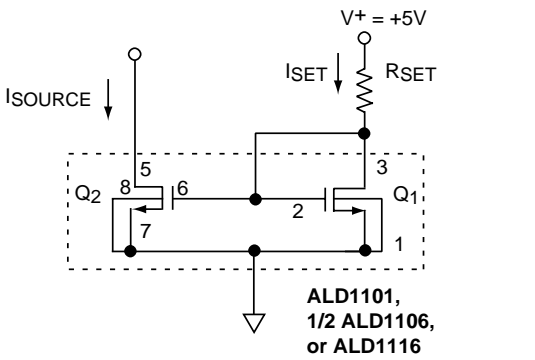

$$I_{SOURCE} = I_{SET} = \frac{V^+ - V_t}{R_{SET}} \cong \frac{V^+ - 1.0}{R_{SET}} \cong \frac{4}{R_{SET}}$$

Q1, Q2 : N - Channel MOSFET

### P- CHANNEL CURRENT SOURCE

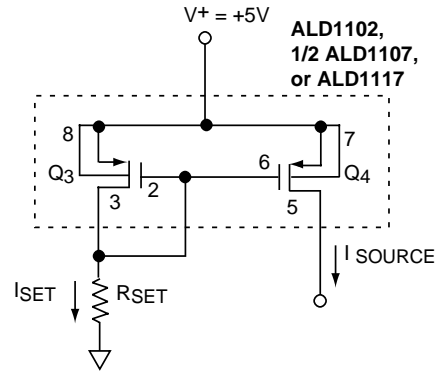

Q3, Q4: P - Channel MOSFET

## CASCODE CURRENT SOURCES

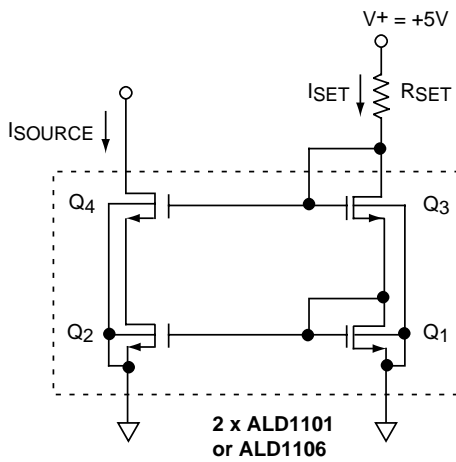

Q1, Q2, Q3, Q4: N - Channel MOSFET  
(ALD1101 or ALD1103)

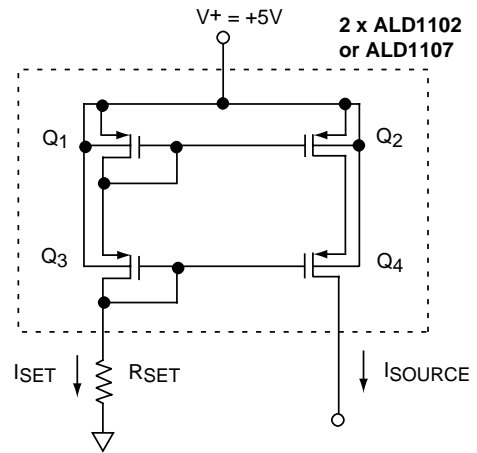

$$I_{SOURCE} = I_{SET} = \frac{V^+ - 2V_t}{R_{SET}} \cong \frac{3}{R_{SET}}$$

Q1, Q2, Q3, Q4: P - Channel MOSFET  
(ALD1102 or ALD1103)

# SOIC-8 PACKAGE DRAWING

## 8 Pin Plastic SOIC Package

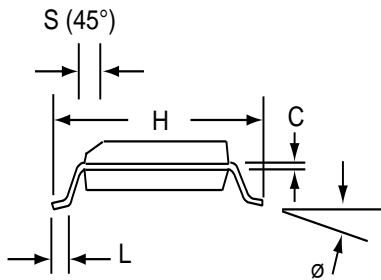
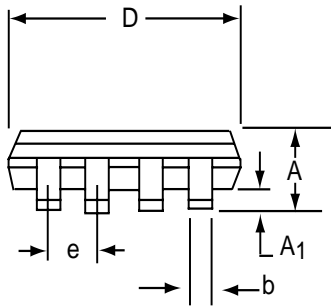
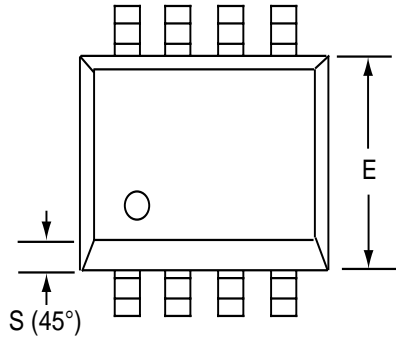

Dim	Millimeters		Inches	
	Min	Max	Min	Max
A	1.35	1.75	0.053	0.069
A <sub>1</sub>	0.10	0.25	0.004	0.010
b	0.35	0.45	0.014	0.018
C	0.18	0.25	0.007	0.010
D-8	4.69	5.00	0.185	0.196
E	3.50	4.05	0.140	0.160
e	1.27 BSC		0.050 BSC	
H	5.70	6.30	0.224	0.248
L	0.60	0.937	0.024	0.037
∅	0°	8°	0°	8°
S	0.25	0.50	0.010	0.020

# PDIP-8 PACKAGE DRAWING

## 8 Pin Plastic DIP Package

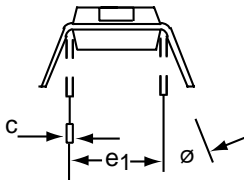
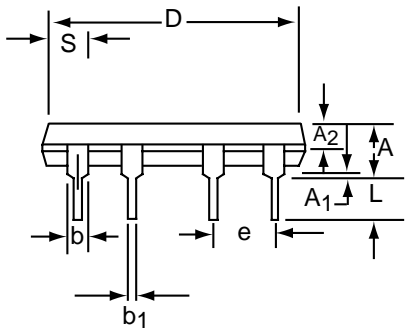
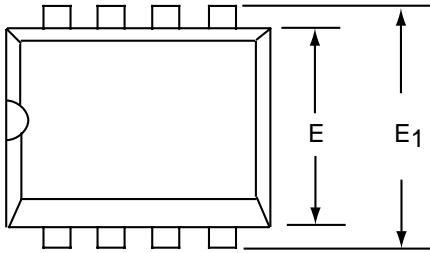

Dim	Millimeters		Inches	
	Min	Max	Min	Max
A	3.81	5.08	0.105	0.200
A <sub>1</sub>	0.38	1.27	0.015	0.050
A <sub>2</sub>	1.27	2.03	0.050	0.080
b	0.89	1.65	0.035	0.065
b <sub>1</sub>	0.38	0.51	0.015	0.020
c	0.20	0.30	0.008	0.012
D-8	9.40	11.68	0.370	0.460
E	5.59	7.11	0.220	0.280
E <sub>1</sub>	7.62	8.26	0.300	0.325
e	2.29	2.79	0.090	0.110
e <sub>1</sub>	7.37	7.87	0.290	0.310
L	2.79	3.81	0.110	0.150
S-8	1.02	2.03	0.040	0.080
ø	0°	15°	0°	15°

# CERDIP-8 PACKAGE DRAWING

## 8 Pin CERDIP Package

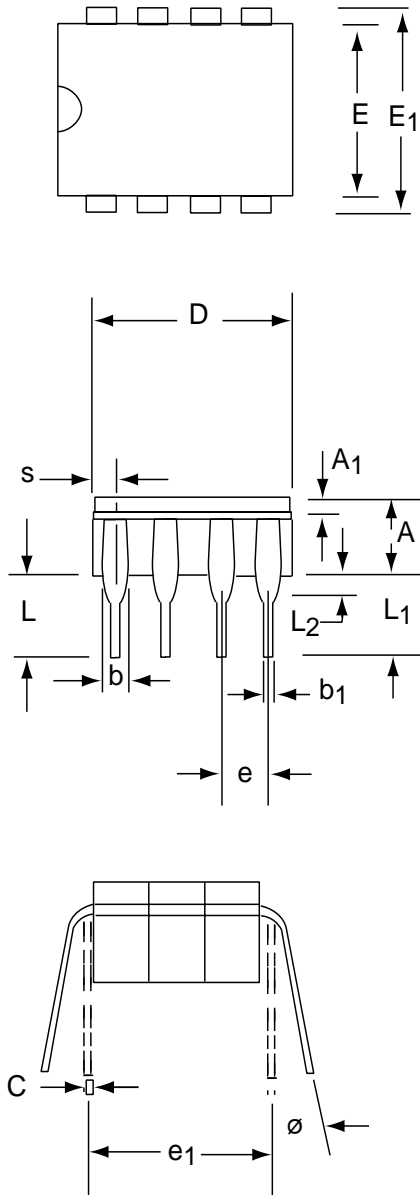

Dim	Millimeters		Inches	
	Min	Max	Min	Max
A	3.55	5.08	0.140	0.200
A <sub>1</sub>	1.27	2.16	0.050	0.085
b	0.97	1.65	0.038	0.065
b <sub>1</sub>	0.36	0.58	0.014	0.023
C	0.20	0.38	0.008	0.015
D-8	--	10.29	--	0.405
E	5.59	7.87	0.220	0.310
E <sub>1</sub>	7.73	8.26	0.290	0.325
e	2.54 BSC		0.100 BSC	
e <sub>1</sub>	7.62 BSC		0.300 BSC	
L	3.81	5.08	0.150	0.200
L <sub>1</sub>	3.18	--	0.125	--
L <sub>2</sub>	0.38	1.78	0.015	0.070
S	--	2.49	--	0.098
∅	0°	15°	0°	15°



# SOIC-14 PACKAGE DRAWING

## 14 Pin Plastic SOIC Package

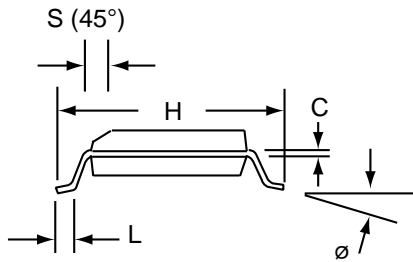
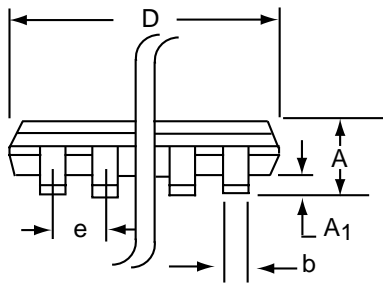
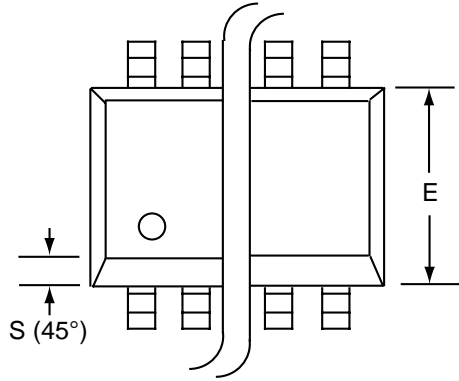

Dim	Millimeters		Inches	
	Min	Max	Min	Max
A	1.35	1.75	0.053	0.069
A <sub>1</sub>	0.10	0.25	0.004	0.010
b	0.35	0.45	0.014	0.018
C	0.18	0.25	0.007	0.010
D-14	8.55	8.75	0.336	0.345
E	3.50	4.05	0.140	0.160
e	1.27 BSC		0.050 BSC	
H	5.70	6.30	0.224	0.248
L	0.60	0.937	0.024	0.037
ø	0°	8°	0°	8°
S	0.25	0.50	0.010	0.020

# PDIP-14 PACKAGE DRAWING

## 14 Pin Plastic DIP Package

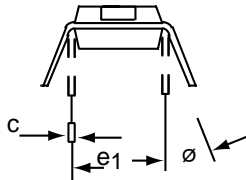
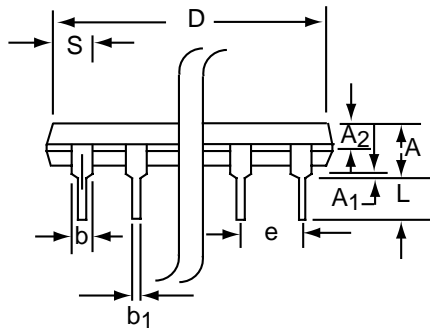
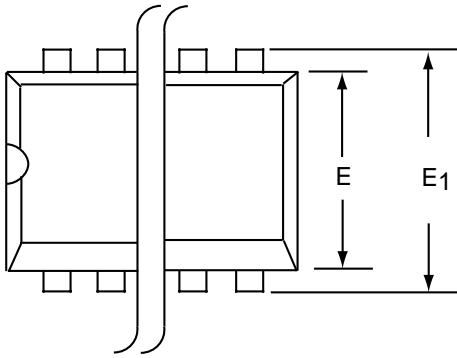

Dim	Millimeters		Inches	
	Min	Max	Min	Max
A	3.81	5.08	0.105	0.200
A <sub>1</sub>	0.38	1.27	0.015	0.050
A <sub>2</sub>	1.27	2.03	0.050	0.080
b	0.89	1.65	0.035	0.065
b <sub>1</sub>	0.38	0.51	0.015	0.020
c	0.20	0.30	0.008	0.012
D-14	17.27	19.30	0.680	0.760
E	5.59	7.11	0.220	0.280
E <sub>1</sub>	7.62	8.26	0.300	0.325
e	2.29	2.79	0.090	0.110
e <sub>1</sub>	7.37	7.87	0.290	0.310
L	2.79	3.81	0.110	0.150
S-14	1.02	2.03	0.040	0.080
ø	0°	15°	0°	15°

# CERDIP-14 PACKAGE DRAWING

## 14 Pin CERDIP Package

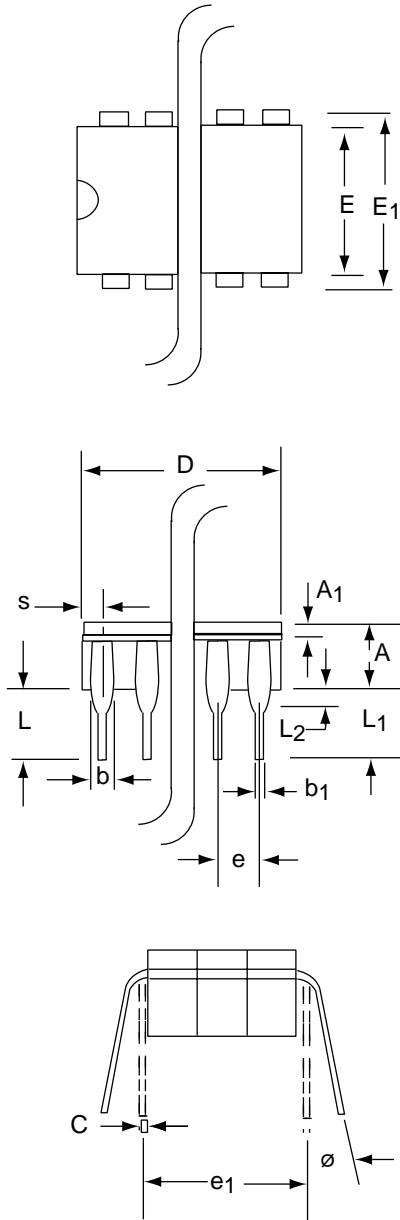

Dim	Millimeters		Inches	
	Min	Max	Min	Max
<b>A</b>	3.55	5.08	0.140	0.200
<b>A<sub>1</sub></b>	1.27	2.16	0.050	0.085
<b>b</b>	0.97	1.65	0.038	0.065
<b>b<sub>1</sub></b>	0.36	0.58	0.014	0.023
<b>C</b>	0.20	0.38	0.008	0.015
<b>D-14</b>	--	19.94	--	0.785
<b>E</b>	5.59	7.87	0.220	0.310
<b>E<sub>1</sub></b>	7.73	8.26	0.290	0.325
<b>e</b>	2.54 BSC		0.100 BSC	
<b>e<sub>1</sub></b>	7.62 BSC		0.300 BSC	
<b>L</b>	3.81	5.08	0.150	0.200
<b>L<sub>1</sub></b>	3.18	--	0.125	--
<b>L<sub>2</sub></b>	0.38	1.78	0.015	0.070
<b>S</b>	--	2.49	--	0.098
<b>Ø</b>	0°	15°	0°	15°

Компания «Океан Электроники» предлагает заключение долгосрочных отношений при поставках импортных электронных компонентов на взаимовыгодных условиях!

Наши преимущества:

- Поставка оригинальных импортных электронных компонентов напрямую с производств Америки, Европы и Азии, а так же с крупнейших складов мира;
- Широкая линейка поставок активных и пассивных импортных электронных компонентов (более 30 млн. наименований);
- Поставка сложных, дефицитных, либо снятых с производства позиций;
- Оперативные сроки поставки под заказ (от 5 рабочих дней);
- Экспресс доставка в любую точку России;
- Помощь Конструкторского Отдела и консультации квалифицированных инженеров;
- Техническая поддержка проекта, помощь в подборе аналогов, поставка прототипов;
- Поставка электронных компонентов под контролем ВП;
- Система менеджмента качества сертифицирована по Международному стандарту ISO 9001;
- При необходимости вся продукция военного и аэрокосмического назначения проходит испытания и сертификацию в лаборатории (по согласованию с заказчиком);
- Поставка специализированных компонентов военного и аэрокосмического уровня качества (Xilinx, Altera, Analog Devices, Intersil, Interpoint, Microsemi, Actel, Aeroflex, Peregrine, VPT, Syfer, Eurofarad, Texas Instruments, MS Kennedy, Miteq, Cobham, E2V, MA-COM, Hittite, Mini-Circuits, General Dynamics и др.);

Компания «Океан Электроники» является официальным дистрибьютором и эксклюзивным представителем в России одного из крупнейших производителей разъемов военного и аэрокосмического назначения «JONHON», а так же официальным дистрибьютором и эксклюзивным представителем в России производителя высокотехнологичных и надежных решений для передачи СВЧ сигналов «FORSTAR».



## JONHON

«JONHON» (основан в 1970 г.)

Разъемы специального, военного и аэрокосмического назначения:

(Применяются в военной, авиационной, аэрокосмической, морской, железнодорожной, горно- и нефтедобывающей отраслях промышленности)

«FORSTAR» (основан в 1998 г.)

ВЧ соединители, коаксиальные кабели, кабельные сборки и микроволновые компоненты:

(Применяются в телекоммуникациях гражданского и специального назначения, в средствах связи, РЛС, а так же военной, авиационной и аэрокосмической отраслях промышленности).



Телефон: 8 (812) 309-75-97 (многоканальный)

Факс: 8 (812) 320-03-32

Электронная почта: [ocean@oceanchips.ru](mailto:ocean@oceanchips.ru)

Web: <http://oceanchips.ru/>

Адрес: 198099, г. Санкт-Петербург, ул. Калинина, д. 2, корп. 4, лит. А