



## **Auto Fan Device with Piecewise Linear Control, Temperature Monitoring & Voltage Monitoring for Multi-Processor Systems**

### **PRODUCT FEATURES**

**Data Brief**

- 3.3 Volt Operation (5 Volt Tolerant Input Buffers)
- SMBus 2.0 Compliant Interface (Fixed, Not Discoverable) With Three Slave Address Options
  - SMBus address change pin
  - SMBus address enable pin
- Auto-Fan Control with Prochot Features
  - PWM (Pulse width Modulation) Outputs (3)
  - Low Frequency and High Frequency PWM Options (15kHz up to 30kHz)
  - Fan Tachometer or Lock Rotor Inputs (4)
  - Programmable automatic fan control based on temperature
  - Acoustic enhancement mode
  - Prochot pins modulate T<sub>min</sub>
  - Fan RPM is a function of up to three temperatures and Prochot signals
  - Piecewise linear fan control algorithm option
- Temperature Monitor
  - Monitoring of up to Five Remote Thermal Diodes (+/- 3 deg C accuracy)
  - Internal Ambient Temperature Measurement
  - Limit Comparison of all Monitored Values
  - Interrupt Pin for out-of-limit Temperature Indication
  - Configurable offset for internal or external temperature channels.
- Voltage Monitor
  - Monitor Power supplies (+1.5V, +2.5V, +5V, VCC and two 1.5V VCCP)
  - Limit Comparison of all Monitored Values
  - Interrupt Pin for out-of-limit Voltage Indication
- Prochot Input/Bi-directional Pins (2)
  - Selectable pins dedicated as input or input/output
  - Seperate Prochot Output pin (FORCED\_PR#)
- Power Good Output
- SMBus Alert Interrupt Output
- Register Characteristics
  - Individual enables/disables for each input
  - Two ISRs for each alert
- XOR Tree Test Mode
- Mechanical Package: 36-pin QFN, lead-free RoHS Compliant

**ORDER NUMBER:**

**EMC6W201-AEZG FOR 36-PIN QFN LEAD-FREE ROHS COMPLIANT PACKAGE**



80 ARKAY DRIVE, HAUPPAUGE, NY 11788 (631) 435-6000, FAX (631) 273-3123

Copyright © 2007 SMSC or its subsidiaries. All rights reserved.

Circuit diagrams and other information relating to SMSC products are included as a means of illustrating typical applications. Consequently, complete information sufficient for construction purposes is not necessarily given. Although the information has been checked and is believed to be accurate, no responsibility is assumed for inaccuracies. SMSC reserves the right to make changes to specifications and product descriptions at any time without notice. Contact your local SMSC sales office to obtain the latest specifications before placing your product order. The provision of this information does not convey to the purchaser of the described semiconductor devices any licenses under any patent rights or other intellectual property rights of SMSC or others. All sales are expressly conditional on your agreement to the terms and conditions of the most recently dated version of SMSC's standard Terms of Sale Agreement dated before the date of your order (the "Terms of Sale Agreement"). The product may contain design defects or errors known as anomalies which may cause the product's functions to deviate from published specifications. Anomaly sheets are available upon request. SMSC products are not designed, intended, authorized or warranted for use in any life support or other application where product failure could cause or contribute to personal injury or severe property damage. Any and all such uses without prior written approval of an Officer of SMSC and further testing and/or modification will be fully at the risk of the customer. Copies of this document or other SMSC literature, as well as the Terms of Sale Agreement, may be obtained by visiting SMSC's website at <http://www.smisc.com>. SMSC is a registered trademark of Standard Microsystems Corporation ("SMSC"). Product names and company names are the trademarks of their respective holders.

**SMSC DISCLAIMS AND EXCLUDES ANY AND ALL WARRANTIES, INCLUDING WITHOUT LIMITATION ANY AND ALL IMPLIED WARRANTIES OF MERCHANTABILITY, FITNESS FOR A PARTICULAR PURPOSE, TITLE, AND AGAINST INFRINGEMENT AND THE LIKE, AND ANY AND ALL WARRANTIES ARISING FROM ANY COURSE OF DEALING OR USAGE OF TRADE. IN NO EVENT SHALL SMSC BE LIABLE FOR ANY DIRECT, INCIDENTAL, INDIRECT, SPECIAL, PUNITIVE, OR CONSEQUENTIAL DAMAGES; OR FOR LOST DATA, PROFITS, SAVINGS OR REVENUES OF ANY KIND; REGARDLESS OF THE FORM OF ACTION, WHETHER BASED ON CONTRACT; TORT; NEGLIGENCE OF SMSC OR OTHERS; STRICT LIABILITY; BREACH OF WARRANTY; OR OTHERWISE; WHETHER OR NOT ANY REMEDY OF BUYER IS HELD TO HAVE FAILED OF ITS ESSENTIAL PURPOSE, AND WHETHER OR NOT SMSC HAS BEEN ADVISED OF THE POSSIBILITY OF SUCH DAMAGES.**

## General Description

---

The EMC6W201 is an environmental monitoring device with automatic fan control capability and enhanced system acoustics for noise suppression. This ACPI compliant device provides hardware monitoring for up to six voltages (including its own VCC) and five external thermal sensors, measures the speed of up to five fans, and controls the speed of multiple DC fans using three Pulse Width Modulator (PWM) outputs. Note that it is possible to control more than three fans by connecting two fans to one PWM output. The EMC6W201 will be available in a 36-pin QFN, lead-free RoHS Compliant package.

The EMC6W201 includes support for monitoring six thermal sensors: five external and one internal. The external temperatures are measured via thermal diode inputs capable of monitoring remote devices. In addition, it is equipped with an ambient temperature sensor for measuring the internal temperature.

The EMC6W201 hardware monitor provides analog inputs for monitoring external voltages of +1.5V, +2.5V, +5V, and two Vccp voltages. This device has the capability to monitor its own internal VCC power supply, which may be connected to either main power (VCC) or the suspend power well (VTR). External components are not required for voltage scaling or similar treatment.

Pulse Width Modulators (PWM) will control the speed of the fans by varying the output duty cycle of the PWM. The Ramp Rate Control feature controls the rate of change of the PWM output, thereby reducing system noise created by changing the fan speed. The speed of each fan is monitored by a Fan Tachometer input. The measured values are compared to values stored in Limit Registers to detect if a fan has stalled or seized.

Fan speed may be under host software control or automatic. In host control mode, the host software continuously monitors temperature and fan speed registers, makes decisions as to desired fan speed and sets each PWM to drive the required fan speed. The PWM frequency is adjustable up to 30kHz. The EMC6W201 device offers an interrupt output signal (INT#), which may be used to interrupt the host on out-of-limit temperature or voltage condition enabling an ACPI response as opposed to the host software continuously monitoring status.

In auto “zone” mode, the EMC6W201 logic continuously monitors the temperature and fan speeds and adjusts speeds without intervention from the host CPU. Fan speed is adjusted according to an algorithm using the temperature measured in the selected zone, the high and low limits set by the user, and the current fan speed. The part can automatically adjust its operation based on its environment for improved acoustic behavior.

## Overview

The EMC6W201 device is an intelligent fan control system with reduced overall acoustic noise features. The EMC6W201 monitors voltages, external temperatures, and fan speeds. It uses this monitoring capability to alert the system to out of limit conditions and can automatically control the speeds of multiple fans.

# Pin Configuration

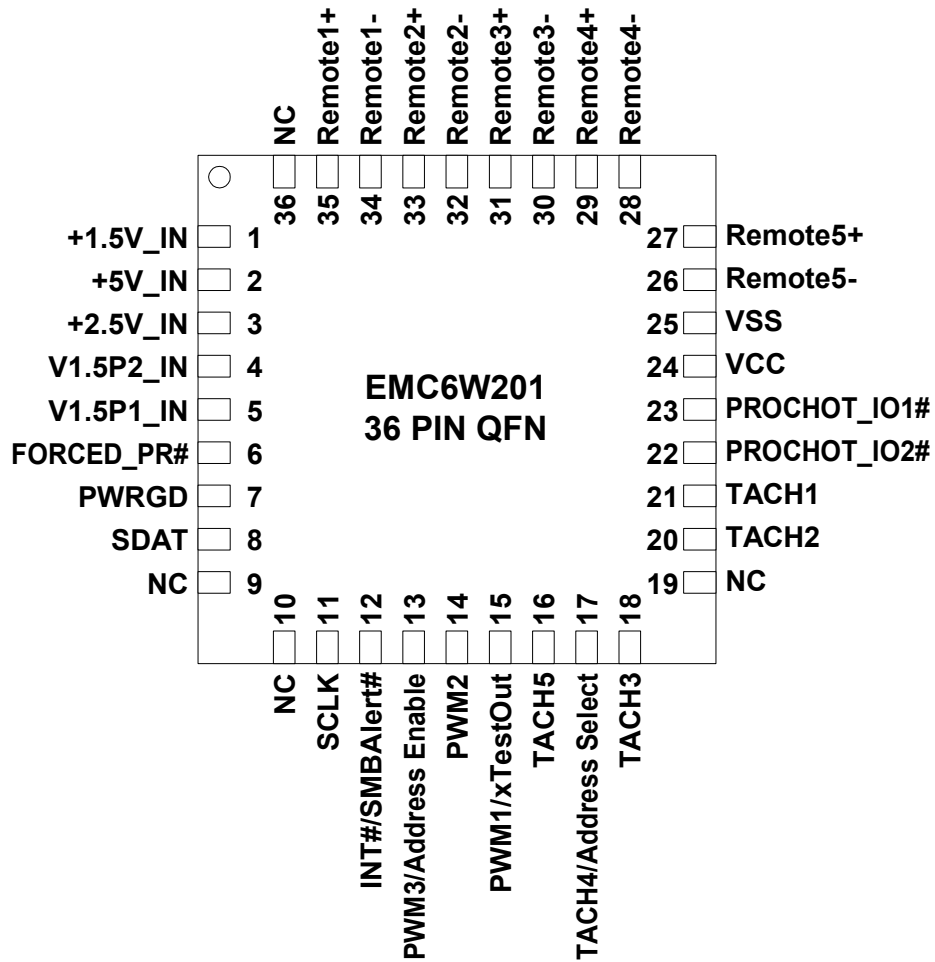

Figure 1 EMC6W201 Pin Configuration

# Package Outline

Revision 0.3 (03-01-07)

5  
PRODUCT PREVIEW

SMSC EMC6W201

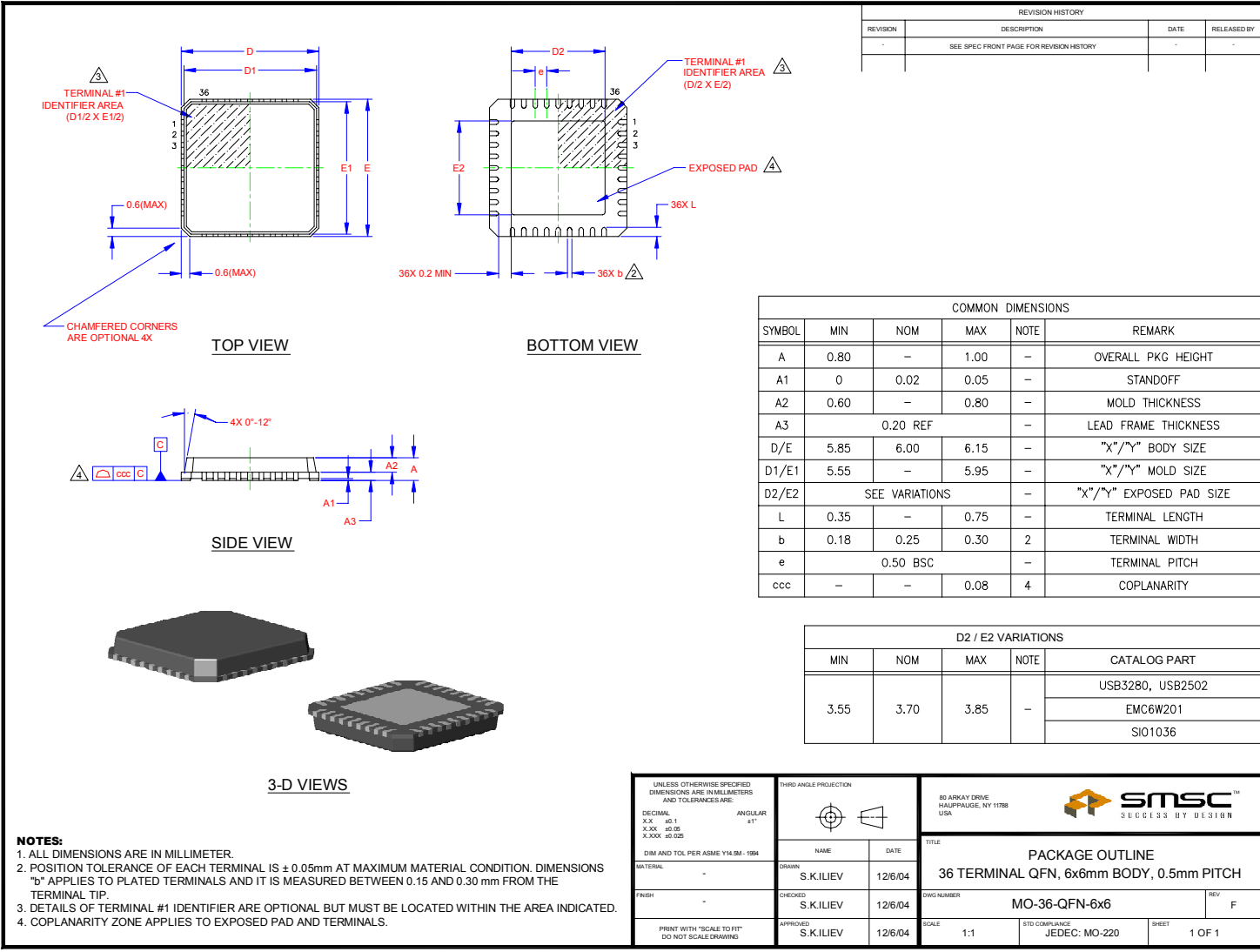

Figure 2 EMC6W201 36-Pin QFN Package Outline

Auto Fan Device with Piecewise Linear Control, Temperature Monitoring & Voltage Monitoring for Multi-Processor Systems

Компания «Океан Электроники» предлагает заключение долгосрочных отношений при поставках импортных электронных компонентов на взаимовыгодных условиях!

Наши преимущества:

- Поставка оригинальных импортных электронных компонентов напрямую с производств Америки, Европы и Азии, а так же с крупнейших складов мира;
- Широкая линейка поставок активных и пассивных импортных электронных компонентов (более 30 млн. наименований);
- Поставка сложных, дефицитных, либо снятых с производства позиций;
- Оперативные сроки поставки под заказ (от 5 рабочих дней);
- Экспресс доставка в любую точку России;
- Помощь Конструкторского Отдела и консультации квалифицированных инженеров;
- Техническая поддержка проекта, помощь в подборе аналогов, поставка прототипов;
- Поставка электронных компонентов под контролем ВП;
- Система менеджмента качества сертифицирована по Международному стандарту ISO 9001;
- При необходимости вся продукция военного и аэрокосмического назначения проходит испытания и сертификацию в лаборатории (по согласованию с заказчиком);
- Поставка специализированных компонентов военного и аэрокосмического уровня качества (Xilinx, Altera, Analog Devices, Intersil, Interpoint, Microsemi, Actel, Aeroflex, Peregrine, VPT, Syfer, Eurofarad, Texas Instruments, MS Kennedy, Miteq, Cobham, E2V, MA-COM, Hittite, Mini-Circuits, General Dynamics и др.);

Компания «Океан Электроники» является официальным дистрибьютором и эксклюзивным представителем в России одного из крупнейших производителей разъемов военного и аэрокосмического назначения «**JONHON**», а так же официальным дистрибьютором и эксклюзивным представителем в России производителя высокотехнологичных и надежных решений для передачи СВЧ сигналов «**FORSTAR**».



## JONHON

«**JONHON**» (основан в 1970 г.)

Разъемы специального, военного и аэрокосмического назначения:

(Применяются в военной, авиационной, аэрокосмической, морской, железнодорожной, горно- и нефтедобывающей отраслях промышленности)

«**FORSTAR**» (основан в 1998 г.)

ВЧ соединители, коаксиальные кабели,  
кабельные сборки и микроволновые компоненты:

(Применяются в телекоммуникациях гражданского и специального назначения, в средствах связи, РЛС, а так же военной, авиационной и аэрокосмической отраслях промышленности).



Телефон: 8 (812) 309-75-97 (многоканальный)

Факс: 8 (812) 320-03-32

Электронная почта: [ocean@oceanchips.ru](mailto:ocean@oceanchips.ru)

Web: <http://oceanchips.ru/>

Адрес: 198099, г. Санкт-Петербург, ул. Калинина, д. 2, корп. 4, лит. А