



# PIC16(L)F18455/56

---

---

## 28-Pin Full-Featured, Low Pin Count Microcontrollers with XLP

---

---

### Description

---

PIC16(L)F184XX microcontrollers feature Intelligent Analog, Core Independent Peripherals (CIPs) and communication peripherals combined with eXtreme Low-Power (XLP) for a wide range of general purpose and low-power applications. Features such as a 12-bit Analog-to-Digital Converter with Computation (ADC<sup>2</sup>), Memory Access Partitioning (MAP), the Device Information Area (DIA), Power-saving operating modes, and Peripheral Pin Select (PPS), offer flexible solutions for a wide variety of custom applications.

### Core Features

---

- C Compiler Optimized RISC Architecture
- Only 50 Instructions
- Operating Speed:
  - DC – 32 MHz clock input
  - 125 ns minimum instruction cycle
- Interrupt Capability
- 16-Level Deep Hardware Stack
- Timers:
  - Up to two 24-bit timers
  - Up to four 8-bit timers
  - Up to four 16-bit timers
- Low-Current Power-on Reset (POR)
- Configurable Power-up Timer (PWRT)
- Brown-out Reset (BOR)
- Low-Power BOR (LPBOR) Option
- Windowed Watchdog Timer (WWDT):
  - Variable prescaler selection
  - Variable window size selection
  - Configurable in hardware (Configuration Words) and/or software
- Programmable Code Protection

### Memory

---

- Up to 28 KB Program Flash Memory
- Up to 2 KB Data SRAM Memory

- 256B Data EEPROM
- Direct, Indirect and Relative Addressing modes
- Memory Access Partition (MAP):
  - Write-protect
  - Customizable partition
- Device Information Area (DIA)
- Device Configuration Information (DCI)

## Operating Characteristics

---

- Operating Voltage Range:
  - 1.8V to 3.6V (PIC16LF184XX)
  - 2.3V to 5.5V (PIC16F184XX)
- Temperature Range:
  - Industrial: -40°C to 85°C
  - Extended: -40°C to 125°C

## Power-Saving Operation Modes

---

- Doze: CPU and Peripherals Running at Different Cycle Rates (typically CPU is lower)
- Idle: CPU Halted While Peripherals Operate
- Sleep: Lowest Power Consumption
- Peripheral Module Disable (PMD):
  - Ability to selectively disable hardware module to minimize active power consumption of unused peripherals
- Extreme Low-Power mode (XLP)
  - Sleep: 500 nA typical @ 1.8V
  - Sleep and Watchdog Timer: 900 nA typical @ 1.8V

## eXtreme Low-Power (XLP) Features

---

- Sleep mode: 50 nA @ 1.8, typical
- Watchdog Timer: 500 nA @ 1.8V, typical
- Secondary Oscillator: 500 nA @ 32 kHz
- Operating Current:
  - 8 uA @ 32 kHz, 1.8V, typical
  - 32 uA/MHz @ 1.8V, typical

## Digital Peripherals

---

- Configurable Logic Cell (CLC):
  - 4 CLCs
  - Integrated combinational and sequential logic
- Complementary Waveform Generator (CWG):
  - 3 CWGs

- Rising and falling edge dead-band control
- Full-bridge, half-bridge, 1-channel drive
- Multiple signal sources
- Capture/Compare/PWM (CCP) modules:
  - 5 CCPs
  - 16-bit resolution for Capture/Compare modes
  - 10-bit resolution for PWM mode
- Pulse-Width Modulators (PWM):
  - 2 10-bit PWMs
- Numerically Controlled Oscillator (NCO):
  - Precision linear frequency generator (@50% duty cycle) with 0.0001% step size of source input clock
  - Input Clock:  $0 \text{ Hz} < f_{\text{NCO}} < 32 \text{ MHz}$
  - Resolution:  $f_{\text{NCO}}/2^{20}$
- Peripheral Pin Select (PPS):
  - I/O pin remapping of digital peripherals
- Serial Communications:
  - EUSART
    - 2 EUSART(s)
    - RS-232, RS-485, LIN compatible
    - Auto-Baud Detect, Auto-wake-up on Start.
  - Master Synchronous Serial Port (MSSP)
    - 2 MSSP(s)
    - SPI
    - I<sup>2</sup>C, SMBus and PMBus™ compatible
- Data Signal Modulator (DSM):
  - Modulates a carrier signal with digital data to create custom carrier synchronized output waveforms
- Up to 26 I/O Pins:
  - Individually programmable pull-ups
  - Slew rate control
  - Interrupt-on-change with edge-select
  - Input level selection control (ST or TTL)
  - Digital open-drain enable
- Timer modules:
  - Timer0:
    - 8/16-bit timer/counter
    - Synchronous or asynchronous operation
    - Programmable prescaler/postscaler
    - Time base for capture/compare function
  - Timer1/3/5 with gate control:
    - 16-bit timer/counter
    - Programmable internal or external clock sources
    - Multiple gate sources

- Multiple gate modes
- Time base for capture/compare function
- Timer2/4/6 with Hardware Limit Timer:
  - 8-bit timers
  - Programmable prescaler/postscaler
  - Time base for PWM function
  - Hardware Limit (HLT) and one-shot extensions
  - Selectable clock sources
- Signal Measurement Timer (SMT)
  - 2 SMT(s)
  - 24-bit timer/counter with programmable prescaler

## Analog Peripherals

---

- Analog-to-Digital Converter with Computation (ADC<sup>2</sup>):
  - 12-bit with up to 24 external channels
  - Conversion available during Sleep
  - Automated post-processing
  - Automated math functions on input signals:
    - Averaging, filter calculations, oversampling and threshold comparison
  - Integrated charge pump for low-voltage operation
  - CVD support
- Zero-Cross Detect (ZCD):
  - AC high voltage zero-crossing detection for simplifying TRIAC control
  - Synchronized switching control and timing
- Temperature Sensor Circuit
- Comparator:
  - 2 Comparators
  - Fixed Voltage Reference at (non)inverting input(s)
  - Comparator outputs externally accessible
- Digital-to-Analog Converter (DAC):
  - 5-bit resolution, rail-to-rail
  - Positive Reference Selection
  - Unbuffered I/O pin output
  - Internal connections to ADCs and comparators
- Fixed Voltage Reference (FVR) module:
  - 1.024V, 2.048V and 4.096V output levels

## Flexible Oscillator Structure

---

- High-Precision Internal Oscillator:
  - Software-selectable frequency range up to 32 MHz
  - $\pm 2\%$  at calibration (nominal)
- 4x PLL for use with External Sources:
  - up to 32 MHz (4-8 MHz input)

- 2x PLL for use with the HFINTOSC:
  - up to 32 MHz
- Low-Power Internal 31 kHz Oscillator (LFINTOSC)
- External 32.768 kHz Crystal Oscillator (SOCS)
- External Oscillator Block with:
  - Three crystal/resonator modes up to 20 MHz
  - Three external clock modes up to 32 MHz
  - Fail-Safe Clock Monitor
    - Detects clock source failure
  - Oscillator Start-up Timer (OST)
    - Ensures stability of crystal oscillator sources

## PIC16(L)F184XX Family Types

**Table 1. Devices Included In This Data Sheet**

Device	Program Flash Memory (Words)	Program Flash Memory (Kbytes)	Data Memory (EEPROM) (bytes)	Data SRAM (bytes)	I/O's <sup>(2)</sup>	12-bit ADC <sup>2</sup> (ch)	5-bit DAC	Comparators	CWG	Clock Ref	Timers (8/16-bit)	CCP	PWM	NCO	EUSART	MSSP (I <sup>2</sup> C/SPI)	CLC	DSM	PPS	XLP	PMD	Windowed Watchdog Timer	Memory Access Partition	Device Information Area	Debug <sup>(1)</sup>	
PIC16(L)F18455	8192	14	256	1024	26	24	1	2	3	1	4/4	5	2	1	2	2	4	1	Y	Y	Y	Y	Y	Y	Y	I
PIC16(L)F18456	16384	28	256	2048	26	24	1	2	3	1	4/4	5	2	1	2	2	4	1	Y	Y	Y	Y	Y	Y	Y	I

**Note:**

1. I - Debugging integrated on-chip.
2. One pin is input-only.

**Table 2. Devices Not Included In This Data Sheet**

Device	Program Flash Memory (Words)	Program Flash Memory (Kbytes)	Data Memory (EEPROM) (bytes)	Data SRAM (bytes)	I/O's <sup>(2)</sup>	12-bit ADC <sup>2</sup> (ch)	5-bit DAC	Comparators	CWG	Clock Ref	Timers (8/16-bit)	CCP	PWM	NCO	EUSART	MSSP (I <sup>2</sup> C/SPI)	CLC	DSM	PPS	XLP	PMD	Windowed Watchdog Timer	Memory Access Partition	Device Information Area	Debug <sup>(1)</sup>	
PIC16(L)F18424	4096	7	256	512	12	11	1	2	2	1	4/4	4	2	1	1	1	4	1	Y	Y	Y	Y	Y	Y	Y	I
PIC16(L)F18425	8192	14	256	1024	12	11	1	2	2	1	4/4	4	2	1	1	2	4	1	Y	Y	Y	Y	Y	Y	Y	I
PIC16(L)F18426	16384	28	256	2048	12	11	1	2	2	1	4/4	4	2	1	1	2	4	1	Y	Y	Y	Y	Y	Y	Y	I
PIC16(L)F18444	4096	7	256	512	18	17	1	2	2	1	4/4	4	2	1	1	1	4	1	Y	Y	Y	Y	Y	Y	Y	I
PIC16(L)F18445	8192	14	256	1024	18	17	1	2	2	1	4/4	4	2	1	1	2	4	1	Y	Y	Y	Y	Y	Y	Y	I
PIC16(L)F18446	16384	28	256	2048	18	17	1	2	2	1	4/4	4	2	1	1	2	4	1	Y	Y	Y	Y	Y	Y	Y	I

Data Sheet Index:

1. [DS40002000A, PIC16\(L\)F18424/44 Data Sheet, 14/20-Pin Full-Featured, Low Pin Count Microcontrollers with XLP](#)
2. [DS40002002A, PIC16\(L\)F18425/45 Data Sheet, 14/20-Pin Full-Featured, Low Pin Count Microcontrollers with XLP](#)
3. [DS40001985A, PIC16\(L\)F18426/46 Data Sheet, 14/20-Pin Full-Featured, Low Pin Count Microcontrollers with XLP](#)

## Packages

Packages	SPDIP	SOIC	SSOP	VQFN (4x4)
PIC16(L)F18455	•	•	•	•
PIC16(L)F18456	•	•	•	•

**Note:** Pin details are subject to change.

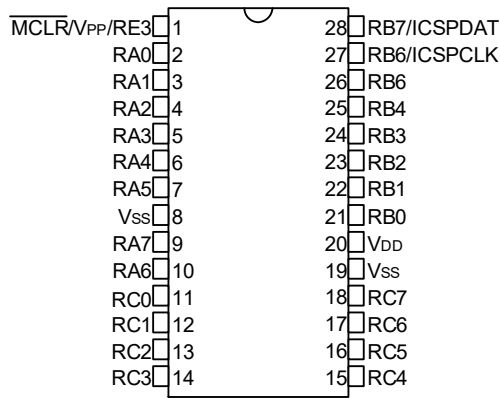


**Important:** For other small form-factor package availability and marking information, visit [www.microchip.com/packaging](http://www.microchip.com/packaging) or contact your local sales office.

Pin Diagrams

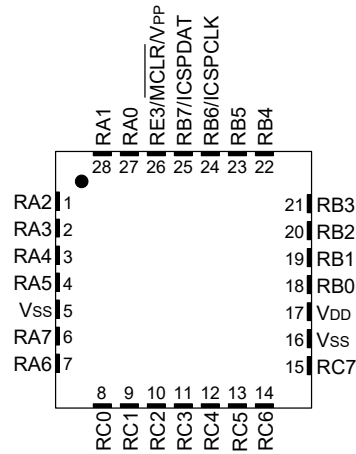
1 28-Pin Diagrams

Figure 1. 28-pin SPDIP, SSOP, SOIC



Rev. 00-00028A  
3/6/2017

Figure 2. 28-pin VQFN



Rev. 00-00028B  
6/23/2017

**Note:** It is recommended that the exposed bottom pad be connected to V<sub>SS</sub>.

Related Links

1 [28-Pin Allocation Table](#)

Pin Allocation Tables

1 28-Pin Allocation Table

I/O	28-pin SPDIP/SOIC/SSOP	28-pin VQFN	ADC	Reference	Comparator	NCO	DAC	DSM	Timers	CCP	PWM	CWG	MSSP	ZCD	EUSART	CLC	CLKR	Interrupts	Pull-Up	Basic	
RA0	2	27	ANA0	—	C1IN0- C2IN0-	—	—	—	—	—	—	—	—	—	—	CLCIN0(1)	—	IOCA0	Y	—	
RA1	3	28	ANA1	—	C1IN1- C2IN1-	—	—	—	—	—	—	—	—	—	—	CLCIN1(1)	—	IOCA1	Y	—	
RA2	4	1	ANA2	ADCVREF-	C1IN0+ C2IN0+	—	DAC1VREF- DAC1OUT1	—	—	—	—	—	—	—	—	—	—	—	IOCA2	Y	—
RA3	5	2	ANA3	ADCVREF+	C1IN1+	—	DAC1VREF+	MDCARL(1)	—	—	—	—	—	—	—	—	—	—	IOCA3	Y	—
RA4	6	3	ANA4	—	—	—	—	MDCARH(1)	T0CKI(1)	CCP5IN(1)	—	—	—	—	—	—	—	—	IOCA4	Y	—
RA5	7	4	ANA5	—	—	—	—	MDSRC(1)	—	—	—	—	SS1(1)	—	—	—	—	—	IOCA5	Y	—
RA6	10	7	ANA6	—	—	—	—	—	—	—	—	—	—	—	—	—	—	—	IOCA6	Y	OSC2 CLKOUT
RA7	9	6	ANA7	—	—	—	—	—	—	—	—	—	—	—	—	—	—	—	IOCA7	Y	OSC1 CLKIN
RB0	21	18	ANB0	—	C2IN1+	—	—	—	—	CCP4IN(1)	—	CWG1IN(1)	—	ZCD1	—	—	—	—	IOCB0	Y	INT(1)
RB1	22	19	ANB1	—	C1IN3- C2IN3-	—	—	—	—	—	—	CWG2IN(1)	SCK2(1) SCL2(1,3)	—	—	—	—	—	IOCB1	Y	—
RB2	23	20	ANB2	—	—	—	—	—	—	—	—	CWG3IN(1)	SDI2(1) SDA2(1,3)SS2(1)	—	—	—	—	—	IOCB2	Y	—
RB3	24	21	ANB3	—	C1IN2- C2IN2-	—	—	—	—	—	—	—	—	—	—	—	—	—	IOCB3	Y	—
RB4	25	22	ANB4 ADACT(1)	—	—	—	—	—	T5G(1) SMT2WIN(1)	—	—	—	—	—	—	—	—	—	IOCB4	Y	—
RB5	26	23	ANB5	—	—	—	—	—	T1G(1) SMT2SIG(1)	CCP3IN(1)	—	—	—	—	—	—	—	—	IOCB5	Y	—
RB6	27	24	ANB6	—	—	—	—	—	—	—	—	—	—	—	CK2(1,3)	CLCIN2(1)	—	—	IOCB6	Y	ICSPCLK ICDCLK
RB7	28	25	ANB7	—	—	—	DAC1OUT2	—	T6IN(1)	—	—	—	—	—	RX2(1) DT2(1,3)	—	—	—	IOCB7	Y	ICSPDAT ICDDAT
RC0	11	8	ANC0	—	—	—	—	—	T1CKI(1) T3CKI(1) T3G(1)	—	—	—	—	—	—	—	—	—	IOCC0	Y	SOSCO



IO	28-pin SPDI/SOC/SSOP	28-pin VQFN	ADC	Reference	Comparator	NCO	DAC	DSM	Timers	CCP	PWM	CWG	MSPP	ZCD	EUSART	GLC	CLKR	Interrupts	Pull-up	Basic	
									SMT1WIN <sup>(1)</sup>												
RC1	12	9	ANC1	—	—	—	—	—	SMT1SIG <sup>(1)</sup>	CCP2IN <sup>(1)</sup>	—	—	—	—	—	—	—	IOCC1	Y	SOSCI	
RC2	13	10	ANC2	—	—	—	—	—	T5CKI <sup>(1)</sup>	CCP1IN <sup>(1)</sup>	—	—	—	—	—	—	—	IOCC2	Y	—	
RC3	14	11	ANC3	—	—	—	—	—	T2IN <sup>(1)</sup>	—	—	—	SCK1 <sup>(1)</sup> SCL1 <sup>(1,3)</sup>	—	—	—	—	IOCC3	Y	—	
RC4	15	12	ANC4	—	—	—	—	—	—	—	—	—	SDI1 <sup>(1)</sup> SDA1 <sup>(1,3)</sup>	—	—	—	—	IOCC4	Y	—	
RC5	16	13	ANC5	—	—	—	—	—	T4IN <sup>(1)</sup>	—	—	—	—	—	—	—	—	IOCC5	Y	—	
RC6	17	14	ANC6	—	—	—	—	—	—	—	—	—	—	—	—	CK1 <sup>(1,3)</sup>	—	IOCC6	Y	—	
RC7	18	15	ANC7	—	—	—	—	—	—	—	—	—	—	—	—	RX1 <sup>(1)</sup> DT1 <sup>(1,3)</sup>	—	IOCC7	Y	—	
RE3	1	26	—	—	—	—	—	—	—	—	—	—	—	—	—	—	—	IOCE3	Y	MCLR VPP	
VDD	20	17	—	—	—	—	—	—	—	—	—	—	—	—	—	—	—	—	—	—	VDD
VSS	8	5	—	—	—	—	—	—	—	—	—	—	—	—	—	—	—	—	—	—	VSS
VSS	19	16	—	—	—	—	—	—	—	—	—	—	—	—	—	—	—	—	—	—	VSS
OUT <sup>(2)</sup>	—	—	ADCGRDA	—	C1OUT	NCO1OUT	—	DSM1OUT	TMR0OUT	CCP1OUT	PWM6OUT	CWG1A CWG2A CWG3A	SDO1 SDO2	—	DT1 <sup>(3)</sup> DT2 <sup>(3)</sup>	CLC1OUT	CLKR	—	—	—	
	—	—	ADCGRDB	—	C2OUT	—	—	—	—	CCP2OUT	PWM7OUT	CWG1B CWG2B CWG3B	SCK1 SCK2	—	CK1 <sup>(3)</sup> CK2 <sup>(3)</sup>	CLC2OUT	—	—	—	—	
	—	—	—	—	—	—	—	—	—	CCP3OUT	—	CWG1C CWG2C CWG3C	SCL1 <sup>(3)</sup> SCL2 <sup>(3)</sup>	—	TX1 TX2	CLC3OUT	—	—	—	—	
	—	—	—	—	—	—	—	—	—	CCP4OUT	—	CWG1D CWG2D CWG3D	SDA1 <sup>(3)</sup> SDA2 <sup>(3)</sup>	—	—	CLC4OUT	—	—	—	—	
—	—	—	—	—	—	—	—	—	—	CCP5OUT	—	—	—	—	—	—	—	—	—	—	

**Note:**

1. This is a PPS re-mappable input signal. The input function may be moved from the default location shown to one of several other PORTx pins.
2. All digital output signals shown in these rows are PPS re-mappable. These signals may be mapped to output onto one of several PORTx pin options.
3. This is a bidirectional signal. For normal module operation, the firmware should map this signal to the same pin in both the PPS input and PPS output registers.

## Table of Contents

Description.....	1
Core Features.....	1
Memory.....	1
Operating Characteristics.....	2
Power-Saving Operation Modes.....	2
eXtreme Low-Power (XLP) Features.....	2
Digital Peripherals.....	2
Analog Peripherals.....	4
Flexible Oscillator Structure.....	4
PIC16(L)F184XX Family Types.....	5
Packages.....	6
Pin Diagrams.....	7
1. 28-Pin Diagrams.....	7
Pin Allocation Tables.....	8
1. 28-Pin Allocation Table.....	8
1. Device Overview.....	20
1.1. New Core Features.....	20
1.2. Other Special Features.....	21
1.3. Details on Individual Family Members.....	21
1.4. Register and Bit Naming Conventions.....	23
2. Guidelines for Getting Started with PIC16(L)F18455/56 Microcontrollers.....	26
2.1. Basic Connection Requirements.....	26
2.2. Power Supply Pins.....	26
2.3. Master Clear (MCLR) Pin.....	27
2.4. In-Circuit Serial Programming™ ICSP™ Pins.....	28
2.5. External Oscillator Pins.....	28
2.6. Unused I/Os.....	30
3. Enhanced Mid-Range CPU.....	31
3.1. Automatic Interrupt Context Saving.....	31
3.2. 16-Level Stack with Overflow and Underflow.....	32
3.3. File Select Registers.....	32

3.4.	Instruction Set.....	32
4.	Device Configuration.....	33
4.1.	Configuration Words.....	33
4.2.	Code Protection.....	33
4.3.	Write Protection.....	33
4.4.	User ID.....	33
4.5.	Device ID and Revision ID.....	34
4.6.	Register Summary - Configuration Words.....	34
4.7.	Register Definitions: Configuration Words.....	34
4.8.	Register Summary - Device and Revision.....	43
4.9.	Register Definitions: Device and Revision.....	43
5.	Device Information Area.....	46
5.1.	Microchip Unique Identifier (MUI).....	47
5.2.	External Unique Identifier (EUI).....	47
5.3.	Analog-to-Digital Conversion Data of the Temperature Sensor.....	48
5.4.	Fixed Voltage Reference Data.....	48
6.	Device Configuration Information.....	49
6.1.	DIA and DCI Access.....	49
7.	Memory Organization.....	50
7.1.	Program Memory Organization.....	50
7.2.	Memory Access Partition (MAP).....	52
7.3.	Data Memory Organization.....	54
7.4.	PCL and PCLATH.....	57
7.5.	Stack.....	59
7.6.	Indirect Addressing.....	62
7.7.	Register Summary - Memory and Status.....	65
7.8.	Register Definitions: Memory and Status.....	66
7.9.	Register Summary: Shadow Registers.....	80
7.10.	Register Definitions: Shadow Registers.....	80
8.	Resets.....	87
8.1.	Power-on Reset (POR).....	88
8.2.	Brown-out Reset (BOR).....	88
8.3.	Low-Power Brown-out Reset (LPBOR).....	89
8.4.	MCLR Reset.....	90
8.5.	Windowed Watchdog Timer (WWDT) Reset.....	91
8.6.	RESET Instruction.....	91
8.7.	Stack Overflow/Underflow Reset.....	91
8.8.	Programming Mode Exit.....	91
8.9.	Power-up Timer (PWRT).....	92
8.10.	Start-up Sequence.....	92
8.11.	Memory Execution Violation.....	93
8.12.	Determining the Cause of a Reset.....	94
8.13.	Power Control (PCONx) Register.....	95

8.14.	Register Summary - BOR Control and Power Control.....	96
8.15.	Register Definitions: Power Control.....	96
9.	Oscillator Module (with Fail-Safe Clock Monitor).....	101
9.1.	Overview.....	101
9.2.	Clock Source Types.....	102
9.3.	Clock Switching.....	108
9.4.	Fail-Safe Clock Monitor.....	111
9.5.	Register Summary - OSC.....	113
9.6.	Register Definitions: Oscillator Control.....	113
10.	Interrupts.....	124
10.1.	Operation.....	124
10.2.	Interrupt Latency.....	125
10.3.	Interrupts During Sleep.....	126
10.4.	INT Pin.....	126
10.5.	Automatic Context Saving.....	127
10.6.	Register Summary - Interrupt Control.....	128
10.7.	Register Definitions: Interrupt Control.....	128
11.	Power-Saving Operation Modes.....	152
11.1.	Doze Mode.....	152
11.2.	Sleep Mode.....	153
11.3.	Idle Mode.....	156
11.4.	Register Summary - Power Savings Control.....	158
11.5.	Register Definitions: Power Savings Control.....	158
12.	(WWDT) Windowed Watchdog Timer.....	162
12.1.	Independent Clock Source.....	163
12.2.	WWDT Operating Modes.....	164
12.3.	Time-out Period.....	164
12.4.	Watchdog Window.....	164
12.5.	Clearing the WWDT.....	165
12.6.	Operation During Sleep.....	165
12.7.	Register Summary - WDT Control.....	167
12.8.	Register Definitions: Windowed Watchdog Timer Control.....	167
13.	(NVM) Nonvolatile Memory Control.....	174
13.1.	Program Flash Memory.....	174
13.2.	Data EEPROM.....	175
13.3.	FSR and INDF Access.....	175
13.4.	NVMREG Access.....	176
13.5.	Register Summary: NVM Control.....	190
13.6.	Register Definitions: Nonvolatile Memory.....	190
14.	I/O Ports.....	196
14.1.	PORT Availability.....	196
14.2.	I/O Ports Description.....	196

14.3.	I/O Priorities.....	197
14.4.	PORTx Registers.....	198
14.5.	PORTE Registers.....	200
14.6.	Register Summary - Input/Output.....	201
14.7.	Register Definitions: Port Control.....	202
15.	(PPS) Peripheral Pin Select Module.....	230
15.1.	PPS Inputs.....	230
15.2.	PPS Outputs.....	232
15.3.	Bidirectional Pins.....	234
15.4.	PPS Lock.....	234
15.5.	PPS Permanent Lock.....	235
15.6.	Operation During Sleep.....	235
15.7.	Effects of a Reset.....	235
15.8.	Register Summary - PPS.....	236
15.9.	Register Definitions: PPS Input and Output Selection.....	238
16.	(PMD) Peripheral Module Disable.....	242
16.1.	Disabling a Module.....	242
16.2.	Enabling a Module.....	242
16.3.	System Clock Disable.....	242
16.4.	Register Summary - PMD.....	243
16.5.	Register Definitions: Peripheral Module Disable.....	243
17.	Interrupt-on-Change.....	253
17.1.	Enabling the Module.....	253
17.2.	Individual Pin Configuration.....	254
17.3.	Interrupt Flags.....	254
17.4.	Operation in Sleep.....	254
17.5.	Register Summary - Interrupt-on-Change.....	255
17.6.	Register Definitions: Interrupt-on-Change Control.....	255
18.	(FVR) Fixed Voltage Reference.....	268
18.1.	Independent Gain Amplifiers.....	268
18.2.	FVR Stabilization Period.....	268
18.3.	Register Summary - FVR.....	270
18.4.	Register Definitions: FVR Control.....	270
19.	Temperature Indicator Module.....	273
19.1.	Module Operation.....	273
19.2.	Minimum Operating $V_{DD}$ .....	274
19.3.	Temperature Indicator Range.....	274
19.4.	Estimation of Temperature.....	274
19.5.	ADC Acquisition Time.....	275
20.	(ADC <sup>2</sup> ) Analog-to-Digital Converter with Computation Module.....	276
20.1.	ADC Configuration.....	277
20.2.	ADC Operation.....	282

20.3. ADC Acquisition Requirements.....	286
20.4. ADC Charge Pump.....	289
20.5. Capacitive Voltage Divider (CVD) Features.....	289
20.6. Computation Operation.....	293
20.7. Register Summary - ADC Control.....	299
20.8. Register Definitions: ADC Control.....	300
<b>21. (DAC) 5-Bit Digital-to-Analog Converter Module.....</b>	<b>324</b>
21.1. Output Voltage Selection.....	325
21.2. Ratiometric Output Level.....	326
21.3. DAC Voltage Reference Output.....	326
21.4. Operation During Sleep.....	326
21.5. Effects of a Reset.....	326
21.6. Register Summary - DAC Control.....	327
21.7. Register Definitions: DAC Control.....	327
<b>22. Numerically Controlled Oscillator (NCO) Module.....</b>	<b>330</b>
22.1. NCO Operation.....	331
22.2. Fixed Duty Cycle Mode.....	332
22.3. Pulse Frequency Mode.....	333
22.4. Output Polarity Control.....	334
22.5. Interrupts.....	334
22.6. Effects of a Reset.....	334
22.7. Operation in Sleep.....	334
22.8. Register Summary - NCO.....	335
22.9. Register Definitions: NCO.....	335
<b>23. (CMP) Comparator Module.....</b>	<b>340</b>
23.1. Comparator Overview.....	340
23.2. Comparator Control.....	341
23.3. Comparator Hysteresis.....	342
23.4. Operation With Timer1 Gate.....	342
23.5. Comparator Interrupt.....	343
23.6. Comparator Positive Input Selection.....	343
23.7. Comparator Negative Input Selection.....	344
23.8. Comparator Response Time.....	345
23.9. Analog Input Connection Considerations.....	345
23.10. CWG1 Auto-Shutdown Source.....	346
23.11. ADC Auto-Trigger Source.....	346
23.12. Even Numbered Timers Reset.....	346
23.13. Operation in Sleep Mode.....	346
23.14. Register Summary - Comparator.....	347
23.15. Register Definitions: Comparator Control.....	347
<b>24. (ZCD) Zero-Cross Detection Module.....</b>	<b>353</b>
24.1. External Resistor Selection.....	354
24.2. ZCD Logic Output.....	354
24.3. ZCD Logic Polarity.....	354

24.4.	ZCD Interrupts.....	355
24.5.	Correction for Z <sub>CPINV</sub> Offset.....	355
24.6.	Handling V <sub>PEAK</sub> Variations.....	357
24.7.	Operation During Sleep.....	358
24.8.	Effects of a Reset.....	358
24.9.	Disabling the ZCD Module.....	358
24.10.	Register Summary: ZCD Control.....	359
24.11.	Register Definitions: ZCD Control.....	359
<b>25.</b>	<b>Timer0 Module.....</b>	<b>361</b>
25.1.	Timer0 Operation.....	362
25.2.	Clock Selection.....	362
25.3.	Timer0 Output and Interrupt.....	363
25.4.	Operation During Sleep.....	364
25.5.	Register Summary - Timer0.....	365
25.6.	Register Definitions: Timer0 Control.....	365
<b>26.</b>	<b>Timer1 Module with Gate Control.....</b>	<b>370</b>
26.1.	Timer1 Operation.....	371
26.2.	Clock Source Selection.....	372
26.3.	Timer1 Prescaler.....	373
26.4.	Secondary Oscillator.....	373
26.5.	Timer1 Operation in Asynchronous Counter Mode.....	374
26.6.	Timer1 16-Bit Read/Write Mode.....	374
26.7.	Timer1 Gate.....	375
26.8.	Timer1 Interrupt.....	380
26.9.	Timer1 Operation During Sleep.....	381
26.10.	CCP Capture/Compare Time Base.....	381
26.11.	CCP Special Event Trigger.....	382
26.12.	Peripheral Module Disable.....	382
26.13.	Register Summary - Timer1 .....	383
26.14.	Register Definitions: Timer1.....	383
<b>27.</b>	<b>Timer2 Module.....</b>	<b>390</b>
27.1.	Timer2 Operation.....	392
27.2.	Timer2 Output.....	393
27.3.	External Reset Sources.....	393
27.4.	Timer2 Interrupt.....	394
27.5.	Operating Modes.....	395
27.6.	Operation Examples.....	397
27.7.	Timer2 Operation During Sleep.....	407
27.8.	Register Summary - Timer2.....	408
27.9.	Register Definitions: Timer2 Control.....	408
<b>28.</b>	<b>CCP/PWM Timer Resource Selection.....</b>	<b>417</b>
28.1.	Register Summary - Timer Selection Registers for CCP/PWM.....	418
28.2.	Register Definitions: CCP/PWM Timer Selection.....	418

29. Capture/Compare/PWM Module.....	421
29.1. CCP Module Configuration.....	421
29.2. Capture Mode.....	422
29.3. Compare Mode.....	424
29.4. PWM Overview.....	426
29.5. Register Summary - CCP Control.....	431
29.6. Register Definitions: CCP Control.....	431
30. (PWM) Pulse-Width Modulation.....	436
30.1. Fundamental Operation.....	437
30.2. PWM Output Polarity.....	437
30.3. PWM Period.....	437
30.4. PWM Duty Cycle.....	438
30.5. PWM Resolution.....	438
30.6. Operation in Sleep Mode.....	439
30.7. Changes in System Clock Frequency.....	439
30.8. Effects of Reset.....	439
30.9. Setup for PWM Operation using PWMx Output Pins.....	439
30.10. Setup for PWM Operation to Other Device Peripherals.....	440
30.11. Register Summary - Registers Associated with PWM.....	441
30.12. Register Definitions: PWM Control.....	441
31. (CWG) Complementary Waveform Generator Module.....	444
31.1. Fundamental Operation.....	444
31.2. Operating Modes.....	444
31.3. Start-up Considerations.....	456
31.4. Clock Source.....	456
31.5. Selectable Input Sources.....	456
31.6. Output Control.....	457
31.7. Dead-Band Control.....	457
31.8. Rising Edge and Reverse Dead Band.....	457
31.9. Falling Edge and Forward Dead Band.....	458
31.10. Dead-Band Jitter.....	459
31.11. Auto-Shutdown.....	459
31.12. Operation During Sleep.....	462
31.13. Configuring the CWG.....	462
31.14. Register Summary - CWG Control.....	464
31.15. Register Definitions: CWG Control.....	464
32. (DSM) Data Signal Modulator Module.....	475
32.1. DSM Operation.....	476
32.2. Modulator Signal Sources.....	476
32.3. Carrier Signal Sources.....	477
32.4. Carrier Synchronization.....	479
32.5. Carrier Source Polarity Select.....	481
32.6. Programmable Modulator Data.....	481
32.7. Modulated Output Polarity.....	481



32.8. Operation in Sleep Mode.....	481
32.9. Effects of a Reset.....	481
32.10. Peripheral Module Disable.....	481
32.11. Register Summary - DSM.....	482
32.12. Register Definitions: Modulation Control.....	482
<b>33. (CLC) Configurable Logic Cell.....</b>	<b>488</b>
33.1. CLC Setup.....	489
33.2. CLC Interrupts.....	494
33.3. Output Mirror Copies.....	495
33.4. Effects of a Reset.....	495
33.5. Operation During Sleep.....	495
33.6. CLC Setup Steps.....	496
33.7. Register Summary - CLC Control.....	497
33.8. Register Definitions: Configurable Logic Cell.....	498
<b>34. Reference Clock Output Module.....</b>	<b>510</b>
34.1. Clock Source.....	511
34.2. Programmable Clock Divider.....	511
34.3. Selectable Duty Cycle.....	512
34.4. Operation in Sleep Mode.....	512
34.5. Register Summary: Reference CLK.....	513
34.6. Register Definitions: Reference Clock.....	513
<b>35. (MSSP) Master Synchronous Serial Port Module.....</b>	<b>516</b>
35.1. SPI Mode Overview.....	516
35.2. SPI Mode Operation.....	518
35.3. I <sup>2</sup> C Mode Overview.....	526
35.4. I <sup>2</sup> C Mode Operation.....	530
35.5. I <sup>2</sup> C Slave Mode Operation.....	534
35.6. I <sup>2</sup> C Master Mode.....	553
35.7. Baud Rate Generator.....	567
35.8. Register Summary: MSSP Control.....	569
35.9. Register Definitions: MSSP Control.....	569
<b>36. (EUSART) Enhanced Universal Synchronous Asynchronous Receiver Transmitter</b>	<b>581</b>
.....	581
36.1. EUSART Asynchronous Mode.....	583
36.2. EUSART Baud Rate Generator (BRG).....	590
36.3. EUSART Synchronous Mode.....	598
36.4. EUSART Operation During Sleep.....	604
36.5. Register Summary - EUSART .....	606
36.6. Register Definitions: EUSART Control.....	606
<b>37. (SMT) Signal Measurement Timer.....</b>	<b>616</b>
37.1. SMT Operation.....	616
37.2. Register Summary - SMT Control.....	630
37.3. Register Definitions: SMT Control.....	630

38. Register Summary.....	643
39. In-Circuit Serial Programming™ (ICSP™) .....	675
39.1. High-Voltage Programming Entry Mode.....	675
39.2. Low-Voltage Programming Entry Mode.....	675
39.3. Common Programming Interfaces.....	675
40. Instruction Set Summary.....	678
40.1. Read-Modify-Write Operations.....	678
40.2. Standard Instruction Set.....	679
41. Development Support.....	701
41.1. MPLAB X Integrated Development Environment Software.....	701
41.2. MPLAB XC Compilers.....	702
41.3. MPASM Assembler.....	702
41.4. MPLINK Object Linker/MPLIB Object Librarian.....	703
41.5. MPLAB Assembler, Linker and Librarian for Various Device Families.....	703
41.6. MPLAB X SIM Software Simulator.....	703
41.7. MPLAB REAL ICE In-Circuit Emulator System.....	704
41.8. MPLAB ICD 3 In-Circuit Debugger System.....	704
41.9. PICkit 3 In-Circuit Debugger/Programmer.....	704
41.10. MPLAB PM3 Device Programmer.....	704
41.11. Demonstration/Development Boards, Evaluation Kits, and Starter Kits.....	704
41.12. Third-Party Development Tools.....	705
42. Electrical Specifications.....	706
42.1. Absolute Maximum Ratings <sup>(†)</sup> .....	706
42.2. Standard Operating Conditions.....	706
42.3. DC Characteristics.....	708
42.4. AC Characteristics.....	719
43. DC and AC Characteristics Graphs and Tables.....	742
43.1. Graphs.....	743
44. Packaging Information.....	744
44.1. Package Details.....	745
45. Revision History.....	755
The Microchip Web Site.....	756
Customer Change Notification Service.....	756
Customer Support.....	756
Product Identification System.....	757
Microchip Devices Code Protection Feature.....	757

Legal Notice.....758  
Trademarks..... 758  
Quality Management System Certified by DNV.....759  
Worldwide Sales and Service.....760

## 1. Device Overview

This document contains device-specific information for the following devices:

• PIC16F18455	• PIC16LF18455
• PIC16F18456	• PIC16LF18456

### 1.1 New Core Features

#### 1.1.1 XLP Technology

All of the devices in the PIC16(L)F184XX family incorporate a range of features that can significantly reduce power consumption during operation. Key items include:

- **Alternate Run Modes:** By clocking the controller from the secondary oscillator or the internal oscillator block, power consumption during code execution can be reduced by as much as 90%.
- **Multiple Idle Modes:** The controller can also run with its CPU core disabled but the peripherals still active. In these states, power consumption can be reduced even further, to as little as 4% of normal operation requirements.
- **On-the-Fly Mode Switching:** The power-managed modes are invoked by user code during operation, allowing the user to incorporate power-saving ideas into their application's software design.
- **Peripheral Module Disable:** Modules that are not being used in the code can be selectively disabled using the PMD module. This further reduces the power consumption.

#### 1.1.2 Multiple Oscillator Options and Features

All of the devices in the PIC16(L)F184XX family offer several different oscillator options. The PIC16(L)F184XX family can be clocked from several different sources:

- HFINTOSC
  - 1-32 MHz precision digitally controlled internal oscillator
- LFINTOSC
  - 31 kHz internal oscillator
- EXTOSC
  - External clock (EC)
  - Low-power oscillator (LP)
  - Medium-power oscillator (XT)
  - High-power oscillator (HS)
- SOSC
  - Secondary oscillator circuit optimized for 32 kHz clock crystals
- A Phase Lock Loop (PLL) frequency multiplier (2x/4x) is available to the External Oscillator modes enabling clock speeds of up to 32 MHz
- Fail-Safe Clock Monitor: This option constantly monitors the main clock source against a reference signal provided by the LFINTOSC. If a clock failure occurs, the controller is switched to the internal oscillator block, allowing for continued operation or a safe application shutdown.

## 1.2 Other Special Features

- **12-bit A/D Converter with Computation:** This module incorporates programmable acquisition time, allowing for a channel to be selected and a conversion to be initiated without waiting for a sampling period and thus, reduce code overhead. It has a new module called ADC<sup>2</sup> with computation features, which provides a digital filter and threshold interrupt functions.
- **Memory Endurance:** The Flash cells for both program memory and data EEPROM are rated to last for many thousands of erase/write cycles – up to 10K for program memory and 100K for EEPROM. Data retention without refresh is conservatively estimated to be greater than 40 years.
- **Self-programmability:** These devices can write to their own program memory spaces under internal software control. By using a boot loader routine located in the protected Boot Block at the top of program memory, it becomes possible to create an application that can update itself in the field.
- **Enhanced Peripheral Pin Select:** The Peripheral Pin Select (PPS) module connects peripheral inputs and outputs to the device I/O pins. Only digital signals are included in the selections. All analog inputs and outputs remain fixed to their assigned pins.
- **Windowed Watchdog Timer (WWDT):**
  - Timer monitoring of overflow and underflow events
  - Variable prescaler selection
  - Variable window size selection
  - All sources configurable in hardware or software

## 1.3 Details on Individual Family Members

The devices of the PIC16(L)F184XX family described in the current datasheet are available in 28-pin packages. The block diagram for this device is shown in [Figure 1-1](#).

The devices have the following differences:

1. Program Flash Memory
2. Data Memory SRAM
3. Data Memory EEPROM
4. A/D channels
5. I/O ports
6. Enhanced USART
7. Input Voltage Range/Power Consumption

All other features for devices in this family are identical. These are summarized in the following Device Features table.

The pinouts for all devices are listed in the pin summary tables.

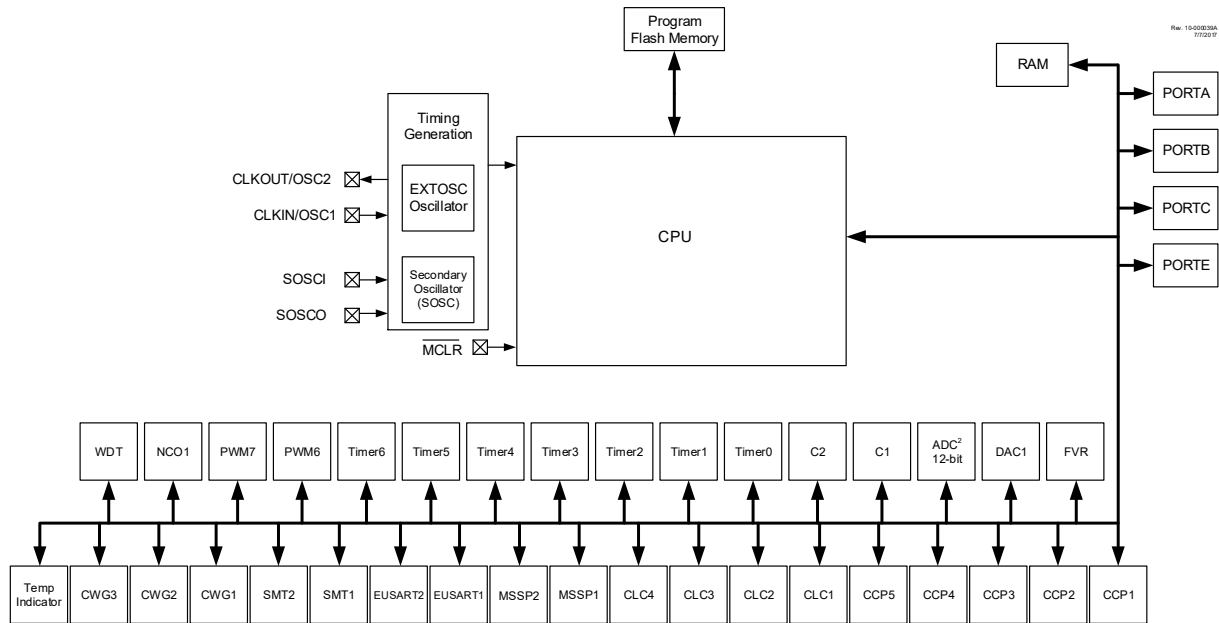
**Table 1-1. Device Features**

Features	PIC16(L)F18455	PIC16(L)F18456
Program Memory (KBytes)	14	28
Program Memory (Instructions)	8192	16384
Data Memory (Bytes)	1024	2048
Data EEPROM Memory (Bytes)	256	256

Features	PIC16(L)F18455	PIC16(L)F18456
Packages	28 - SPDIP 28 - SSOP 28 - SOIC (7.5 mm) 28 - vQFN (4x4)	28 - SPDIP 28 - SSOP 28 - SOIC (7.5 mm) 28 - vQFN (4x4)
I/O Ports	A, B, C	A, B, C
Capture/Compare/PWM Modules (CCP)	5	5
Configurable Logic Cell (CLC)	4	4
10-Bit Pulse-Width Modulator (PWM)	2	2
12-Bit Analog-to-Digital Module (ADC <sup>2</sup> ) with Computation Accelerator	24 channels	24 channels
5-Bit Digital-to-Analog Module (DAC)	1	1
Comparators	2	2
Numerical Controlled Oscillator (NCO)	1	1
Interrupt Sources	47	47
Timers (16-/8-bit)	4	4
Serial Communications	2 MSSP 2 EUSART	2 MSSP 2 EUSART
Complementary Waveform Generator (CWG)	3	3
Zero-Cross Detect (ZCD)	1	1
Data Signal Modulator (DSM)	1	1
Reference Clock Output Module	1	1
Peripheral Pin Select (PPS)	YES	YES
Peripheral Module Disable (PMD)	YES	YES
Programmable Brown-out Reset (BOR)	YES	YES
Resets (and Delays)	POR, BOR, RESET Instruction, Stack Overflow, Stack Underflow (PWRT, OST), MCLR, WDT	POR, BOR, RESET Instruction, Stack Overflow, Stack Underflow (PWRT, OST), MCLR, WDT
Instruction Set	50 instructions	50 instructions

Features	PIC16(L)F18455	PIC16(L)F18456
	16-levels hardware stack	16-levels hardware stack
Operating Frequency	DC – 32 MHz	DC – 32 MHz

Figure 1-1. PIC16(L)F18455/56 Device Block Diagram



**Note:**

1. See applicable chapters for more information on peripherals.

## 1.4 Register and Bit Naming Conventions

### 1.4.1 Register Names

When there are multiple instances of the same peripheral in a device, the Peripheral Control registers will be depicted as the concatenation of a peripheral identifier, peripheral instance, and control identifier. The control registers section will show just one instance of all the register names with an 'x' in the place of the peripheral instance number. This naming convention may also be applied to peripherals when there is only one instance of that peripheral in the device to maintain compatibility with other devices in the family that contain more than one.

### 1.4.2 Bit Names

There are two variants for bit names:

- Short name: Bit function abbreviation
- Long name: Peripheral abbreviation and short name

#### 1.4.2.1 Short Bit Names

Short bit names are an abbreviation for the bit function. For example, some peripherals are enabled with the EN bit. The bit names shown in the registers are the short name variant.

Short bit names are useful when accessing bits in C programs. The general format for accessing bits by the short name is `RegisterNamebits.ShortName`. For example, the enable bit, EN, in the `CM1CON0` register can be set in C programs with the instruction `CM1CON0bits.EN = 1`.

Short names are generally not useful in assembly programs because the same name may be used by different peripherals in different bit positions. When this occurs, during the include file generation, all instances of that short bit name are appended with an underscore plus the name of the register in which the bit resides to avoid naming contentions.

### 1.4.2.2 Long Bit Names

Long bit names are constructed by adding a peripheral abbreviation prefix to the short name. The prefix is unique to the peripheral, thereby making every long bit name unique. The long bit name for the COG1 enable bit is the COG1 prefix, G1, appended with the enable bit short name, EN, resulting in the unique bit name G1EN.

Long bit names are useful in both C and assembly programs. For example, in C the `COG1CON0` enable bit can be set with the `G1EN = 1` instruction. In assembly, this bit can be set with the `BSF COG1CON0, G1EN` instruction.

### 1.4.2.3 Bit Fields

Bit fields are two or more adjacent bits in the same register. Bit fields adhere only to the short bit naming convention. For example, the three Least Significant bits of the `COG1CON0` register contain the mode control bits. The short name for this field is MD. There is no long bit name variant. Bit field access is only possible in C programs. The following example demonstrates a C program instruction for setting the COG1 to the Push-Pull mode:

```
COG1CON0bits.MD = 0x5;
```

Individual bits in a bit field can also be accessed with long and short bit names. Each bit is the field name appended with the number of the bit position within the field. For example, the Most Significant mode bit has the short bit name MD2 and the long bit name is G1MD2. The following two examples demonstrate assembly program sequences for setting the COG1 to Push-Pull mode:

Example 1:

```
MOVLW  ~ (1<<G1MD1)
ANDWF  COG1CON0, F
MOVLW  1<<G1MD2 | 1<<G1MD0
IORWF  COG1CON0, F
```

Example 2:

```
BSF    COG1CON0, G1MD2
BCF    COG1CON0, G1MD1
BSF    COG1CON0, G1MD0
```

## 1.4.3 Register and Bit Naming Exceptions

### 1.4.3.1 Status, Interrupt, and Mirror Bits

Status, interrupt enables, interrupt flags, and mirror bits are contained in registers that span more than one peripheral. In these cases, the bit name shown is unique so there is no prefix or short name variant.

### 1.4.3.2 Legacy Peripherals

There are some peripherals that do not strictly adhere to these naming conventions. Peripherals that have existed for many years and are present in almost every device are the exceptions. These exceptions were necessary to limit the adverse impact of the new conventions on legacy code.



Peripherals that do adhere to the new convention will include a table in the registers section indicating the long name prefix for each peripheral instance. Peripherals that fall into the exception category will not have this table. These peripherals include, but are not limited to the following:

- EUSART
- MSSP

#### 1.4.4 Register Legend

The table below describes the conventions for bit types and bit Reset values used in the current data sheet.

**Table 1-2. Register Legend**

Value	Description
RO	Read-only bit
W	Writable bit
U	Unimplemented bit, read as '0'
P	Programmable bit
'1'	Bit is set
'0'	Bit is cleared
x	Bit is unknown
u	Bit is unchanged
-n/n	Value at POR and BOR/Value at all other Resets
q	Reset Value is determined by hardware
f	Reset Value is determined by fuse setting
g	Reset Value at POR for PPS re-mappable signals

## 2. Guidelines for Getting Started with PIC16(L)F18455/56 Microcontrollers

### 2.1 Basic Connection Requirements

Getting started with the PIC16(L)F18455/56 family of 8-bit microcontrollers requires attention to a minimal set of device pin connections before proceeding with development.

The following pins must always be connected:

- All  $V_{DD}$  and  $V_{SS}$  pins (see [2.2 Power Supply Pins](#))
- $\overline{MCLR}$  pin (see [2.3 Master Clear \(MCLR\) Pin](#))

These pins must also be connected if they are being used in the end application:

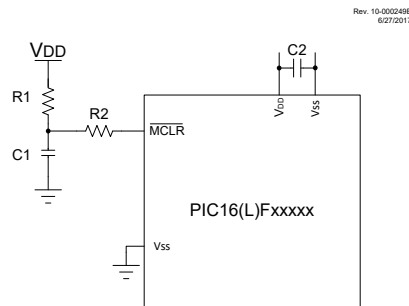
- PGC/PGD pins used for In-Circuit Serial Programming™ (ICSP™) and debugging purposes (see [2.4 In-Circuit Serial Programming™ ICSP™ Pins](#))
- OSCI and OSCO pins when an external oscillator source is used (see [2.5 External Oscillator Pins](#))

Additionally, the following may be required:

- $V_{REF+}/V_{REF-}$  pins are used when external voltage reference for analog modules is implemented

The minimum mandatory connections are shown in the figure below.

**Figure 2-1. Recommended Minimum Connections**



**Key (all values are recommendations):**

- C1: 10 nF, 16V ceramic
- C2: 0.1  $\mu$ F, 16V ceramic
- R1: 10 k $\Omega$
- R2: 100 $\Omega$  to 470 $\Omega$

## 2.2 Power Supply Pins

### 2.2.1 Decoupling Capacitors

The use of decoupling capacitors on every pair of power supply pins ( $V_{DD}$  and  $V_{SS}$ ) is required.

Consider the following criteria when using decoupling capacitors:

- Value and type of capacitor: A 0.1  $\mu$ F (100 nF), 10-25V capacitor is recommended. The capacitor should be a low-ESR device, with a resonance frequency in the range of 200 MHz and higher. Ceramic capacitors are recommended.

- Placement on the printed circuit board: The decoupling capacitors should be placed as close to the pins as possible. It is recommended to place the capacitors on the same side of the board as the device. If space is constricted, the capacitor can be placed on another layer on the PCB using a via; however, ensure that the trace length from the pin to the capacitor is no greater than 0.25 inch (6 mm).
- Handling high-frequency noise: If the board is experiencing high-frequency noise (upward of tens of MHz), add a second ceramic type capacitor in parallel to the above described decoupling capacitor. The value of the second capacitor can be in the range of 0.01  $\mu\text{F}$  to 0.001  $\mu\text{F}$ . Place this second capacitor next to each primary decoupling capacitor. In high-speed circuit designs, consider implementing a decade pair of capacitances as close to the power and ground pins as possible (e.g., 0.1  $\mu\text{F}$  in parallel with 0.001  $\mu\text{F}$ ).
- Maximizing performance: On the board layout from the power supply circuit, run the power and return traces to the decoupling capacitors first, and then to the device pins. This ensures that the decoupling capacitors are first in the power chain. Equally important is to keep the trace length between the capacitor and the power pins to a minimum, thereby reducing PCB trace inductance.

### 2.2.2 Tank Capacitors

On boards with power traces running longer than six inches in length, it is suggested to use a tank capacitor for integrated circuits, including microcontrollers, to supply a local power source. The value of the tank capacitor should be determined based on the trace resistance that connects the power supply source to the device, and the maximum current drawn by the device in the application. In other words, select the tank capacitor that meets the acceptable voltage sag at the device. Typical values range from 4.7  $\mu\text{F}$  to 47  $\mu\text{F}$ .

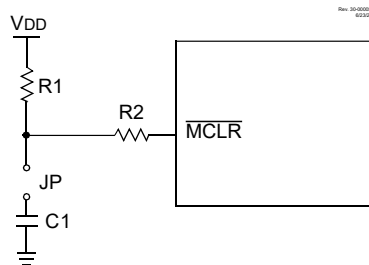
### 2.3 Master Clear ( $\overline{\text{MCLR}}$ ) Pin

The  $\overline{\text{MCLR}}$  pin provides two specific device functions: Device Reset, and Device Programming and Debugging. If programming and debugging are not required in the end application, a direct connection to  $V_{\text{DD}}$  may be all that is required. The addition of other components, to help increase the application's resistance to spurious Resets from voltage sags, may be beneficial. A typical configuration is shown in [Figure 2-1](#). Other circuit designs may be implemented, depending on the application's requirements.

During programming and debugging, the resistance and capacitance that can be added to the pin must be considered. Device programmers and debuggers drive the  $\overline{\text{MCLR}}$  pin. Consequently, specific voltage levels ( $V_{\text{IH}}$  and  $V_{\text{IL}}$ ) and fast signal transitions must not be adversely affected. Therefore, specific values of R1 and C1 will need to be adjusted based on the application and PCB requirements. For example, it is recommended that the capacitor, C1, be isolated from the  $\overline{\text{MCLR}}$  pin during programming and debugging operations by using a jumper ([Figure 2-2](#)). The jumper is replaced for normal run-time operations.

Any components associated with the  $\overline{\text{MCLR}}$  pin should be placed within 0.25 inch (6 mm) of the pin.

**Figure 2-2. Example of  $\overline{\text{MCLR}}$  Pin Connections**



**Note:**

1.  $R1 \leq 10 \text{ k}\Omega$  is recommended. A suggested starting value is  $10 \text{ k}\Omega$ . Ensure that the  $\overline{\text{MCLR}}$  pin  $V_{IH}$  and  $V_{IL}$  specifications are met.
2.  $R2 \leq 470\Omega$  will limit any current flowing into  $\overline{\text{MCLR}}$  from the extended capacitor, C1, in the event of  $\overline{\text{MCLR}}$  pin breakdown, due to Electrostatic Discharge (ESD) or Electrical Overstress (EOS). Ensure that the  $\overline{\text{MCLR}}$  pin  $V_{IH}$  and  $V_{IL}$  specifications are met.

## 2.4 In-Circuit Serial Programming™ ICSP™ Pins

The ICSPCLK and ICSPDAT pins are used for In-Circuit Serial Programming™ (ICSP™) and debugging purposes. It is recommended to keep the trace length between the ICSP connector and the ICSP pins on the device as short as possible. If the ICSP connector is expected to experience an ESD event, a series resistor is recommended, with the value in the range of a few tens of ohms, not to exceed  $100\Omega$ .

Pull-up resistors, series diodes and capacitors on the ICSPCLK and ICSPDAT pins are not recommended as they can interfere with the programmer/debugger communications to the device. If such discrete components are an application requirement, they should be removed from the circuit during programming and debugging. Alternatively, refer to the AC/DC characteristics and timing requirements information in the respective device Flash programming specification for information on capacitive loading limits, and pin input voltage high ( $V_{IH}$ ) and input low ( $V_{IL}$ ) requirements.

For device emulation, ensure that the “Communication Channel Select” (i.e., ICSPCLK/ICSPDAT pins), programmed into the device, matches the physical connections for the ICSP to the Microchip debugger/emulator tool.

For more information on available Microchip development tools connection requirements, refer to the “*Development Support*” section.

### Related Links

[41. Development Support](#)

## 2.5 External Oscillator Pins

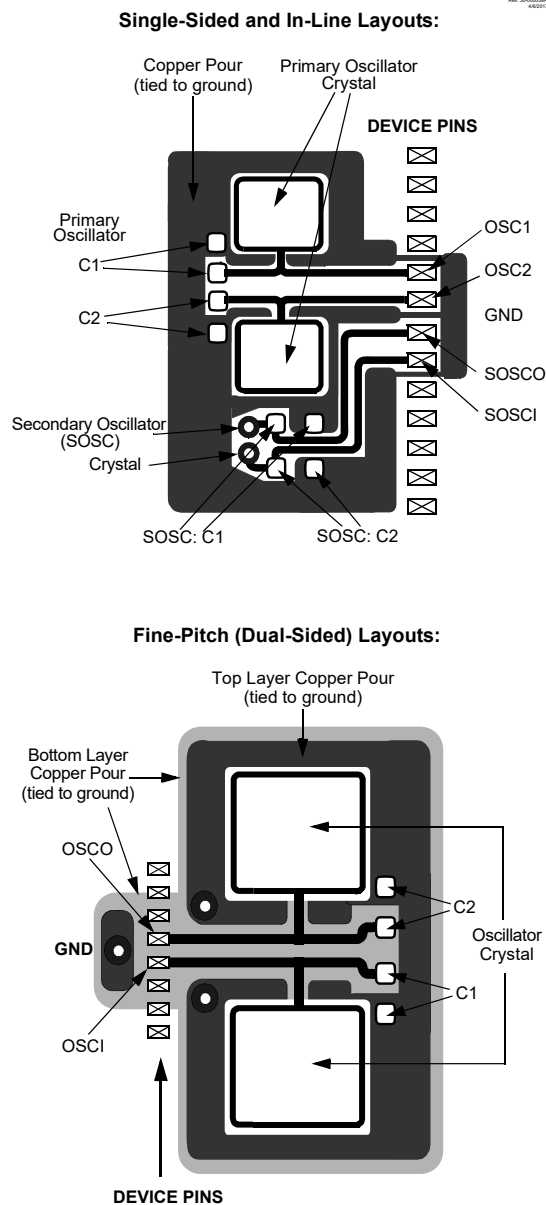
Many microcontrollers have options for at least two oscillators: a high-frequency primary oscillator and a low-frequency secondary oscillator.

The oscillator circuit should be placed on the same side of the board as the device. Place the oscillator circuit close to the respective oscillator pins with no more than 0.5 inch (12 mm) between the circuit components and the pins. The load capacitors should be placed next to the oscillator itself, on the same side of the board.

Use a grounded copper pour around the oscillator circuit to isolate it from surrounding circuits. The grounded copper pour should be routed directly to the MCU ground. Do not run any signal traces or power traces inside the ground pour. Also, if using a two-sided board, avoid any traces on the other side of the board where the crystal is placed.

Layout suggestions are shown in the following figure. In-line packages may be handled with a single-sided layout that completely encompasses the oscillator pins. With fine-pitch packages, it is not always possible to completely surround the pins and components. A suitable solution is to tie the broken guard sections to a mirrored ground layer. In all cases, the guard trace(s) must be returned to ground.

**Figure 2-3. Suggested Placement of the Oscillator Circuit**



In planning the application's routing and I/O assignments, ensure that adjacent port pins, and other signals in close proximity to the oscillator, are benign (i.e., free of high frequencies, short rise and fall times, and other similar noise).

For additional information and design guidance on oscillator circuits, refer to these Microchip Application Notes, available at the corporate website ([www.microchip.com](http://www.microchip.com)):

- AN826, "Crystal Oscillator Basics and Crystal Selection for *rPIC*<sup>™</sup> and *PICmicro*<sup>®</sup> Devices"
- AN849, "Basic *PICmicro*<sup>®</sup> Oscillator Design"
- AN943, "Practical *PICmicro*<sup>®</sup> Oscillator Analysis and Design"
- AN949, "Making Your Oscillator Work"

### Related Links

#### [9. Oscillator Module \(with Fail-Safe Clock Monitor\)](#)

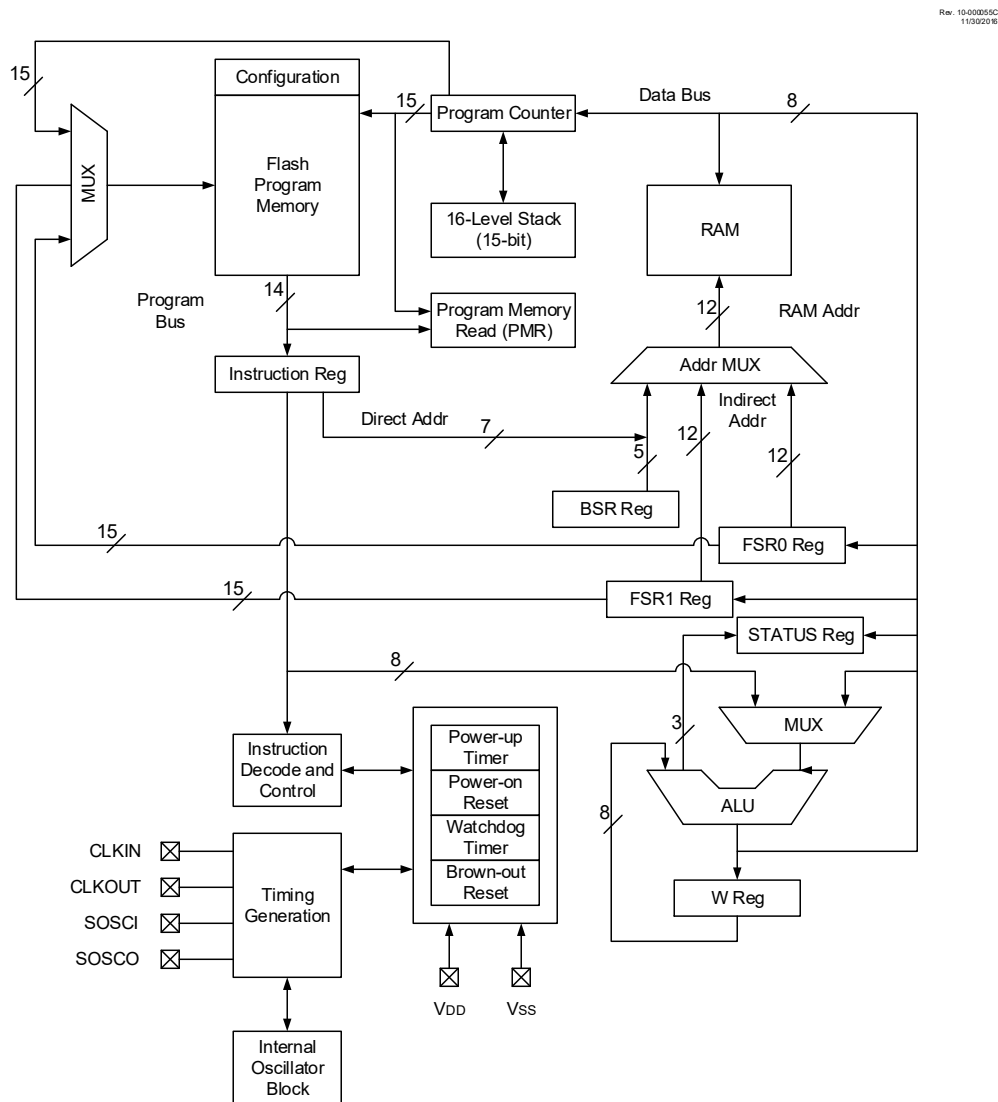
### 2.6 Unused I/Os

Unused I/O pins should be configured as outputs and driven to a logic low state. Alternatively, connect a 1k $\Omega$  to 10 k $\Omega$  resistor to  $V_{SS}$  on unused pins to drive the output to logic low.

### 3. Enhanced Mid-Range CPU

This family of devices contains an enhanced mid-range 8-bit CPU core. The CPU has 50 instructions. Interrupt capability includes automatic context saving. The hardware stack is 16-levels deep and has Overflow and Underflow Reset capability. Direct, Indirect, and Relative Addressing modes are available. The two File Select Registers (FSRs) provide the ability to read program and data memory.

**Figure 3-1. Core Data Path Diagram**



#### 3.1 Automatic Interrupt Context Saving

During interrupts, certain registers are automatically saved in shadow registers and restored when returning from the interrupt. This saves stack space and user code.

**Related Links**

[10.5 Automatic Context Saving](#)

### **3.2 16-Level Stack with Overflow and Underflow**

These devices have a hardware stack memory 15 bits wide and 16 words deep. A Stack Overflow or Underflow will set the appropriate bit (STKOVF or STKUNF) in the PCON0 register, and if enabled, will cause a software Reset.

#### **Related Links**

[7.5 Stack](#)

[8.15.2 PCON0](#)

### **3.3 File Select Registers**

There are two 16-bit File Select Registers (FSR). FSRs can access all file registers and program memory, which allows one Data Pointer for all memory. When an FSR points to program memory, there is one additional instruction cycle in instructions using INDF to allow the data to be fetched. General purpose memory can also be addressed linearly, providing the ability to access contiguous data larger than 80 bytes.

#### **Related Links**

[7.6 Indirect Addressing](#)

### **3.4 Instruction Set**

There are 50 instructions for the enhanced mid-range CPU to support the features of the CPU.

#### **Related Links**

[40. Instruction Set Summary](#)



## 4. Device Configuration

Device configuration consists of the configuration words, user ID, device ID, Device Information Area (DIA), and the Device Configuration Information (DCI) regions.

### Related Links

- [5. Device Information Area](#)
- [6. Device Configuration Information](#)

### 4.1 Configuration Words

The devices have five Configuration Words starting at address 8007h through 800Bh. The Configuration bits establish configuration values prior to the execution of any software; Configuration bits enable or disable device-specific features.

In terms of programming, these important Configuration bits should be considered:

1. **LVP: Low-Voltage Programming Enable Bit**
  - 1 = ON – Low-Voltage Programming is enabled.  $\overline{\text{MCLR}}/\text{V}_{\text{PP}}$  pin function is  $\overline{\text{MCLR}}$ . MCLRE Configuration bit is ignored.
  - 0 = OFF – HV on  $\overline{\text{MCLR}}/\text{V}_{\text{PP}}$  must be used for programming.
2.  **$\overline{\text{CP}}$ : User Nonvolatile Memory (NVM) Program Memory Code Protection bit**
  - 1 = OFF – User NVM code protection disabled
  - 0 = ON – User NVM code protection enabled

### 4.2 Code Protection

Code protection allows the device to be protected from unauthorized access. Program memory protection and data memory protection are controlled independently. Internal access to the program memory is unaffected by any code protection setting.

#### 4.2.1 Program Memory Protection

The entire program memory space is protected from external reads and writes by the  $\overline{\text{CP}}$  bit. When  $\overline{\text{CP}} = 0$ , external reads and writes of program memory are inhibited and a read will return all '0's. The CPU can continue to read program memory, regardless of the protection bit settings. Self-writing the program memory is dependent upon the write protection setting.

### 4.3 Write Protection

Write protection allows the device to be protected from unintended self-writes. Applications, such as boot loader software, can be protected while allowing other regions of the program memory to be modified.

The [WRT](#) bits define the size of the program memory block that is protected.

### 4.4 User ID

Four words in the memory space (8000h-8003h) are designated as ID locations where the user can store checksum or other code identification numbers. These locations are readable and writable during normal execution. See the “*NVMREG Access to Device Information Area, Device Configuration Area, User ID,*

*Device ID, EEPROM, and Configuration Words*” section for more information on accessing these memory locations. For more information on checksum calculation, see the *“PIC16(L)F184XX Memory Programming Specification”*, (DS40001970).

**Related Links**

[13.4.7 NVMREG Access to Device Information Area, Device Configuration Area, User ID, Device ID, EEPROM, and Configuration Words](#)

**4.5 Device ID and Revision ID**

The 14-bit device ID word is located at 0x8006 and the 14-bit revision ID is located at 0x8005. These locations are read-only and cannot be erased or modified.

Development tools, such as device programmers and debuggers, may be used to read the Device ID, Revision ID and Configuration Words. Refer to the *“Nonvolatile Memory (NVM) Control”* section for more information on accessing these locations.

**Related Links**

[13. \(NVM\) Nonvolatile Memory Control](#)

**4.6 Register Summary - Configuration Words**

Offset	Name	Bit Pos.							
0x8007	CONFIG1	7:0		RSTOSC[2:0]			FEXTOSC[2:0]		
		13:8		FCMEN		CSWEN			CLKOUTEN
0x8008	CONFIG2	7:0	BOREN		LPBOREN		PWRTS[1:0]		MCLRE
		13:8		DEBUG	STVREN	PPS1WAY	ZCDDIS	BORV	
0x8009	CONFIG3	7:0	WDTE[1:0]			WDTCPSS[4:0]			
		13:8		WDTCCS[2:0]			WDTCWS[2:0]		
0x800A	CONFIG4	7:0	WRTAPP		SAFEN	BBEN	BBSIZE[2:0]		
		13:8		LVP		WRTSAF	WRTD	WRTC	WRTB
0x800B	CONFIG5	7:0							CP
		13:8							

**4.7 Register Definitions: Configuration Words**

4.7.1 CONFIG1

Name: CONFIG1  
Address: 0x8007

Configuration word 1

Oscillators

Bit	15	14	13	12	11	10	9	8
			FCMEN		CSWEN			CLKOUTEN
Access			R/P	U	R/P	U	U	R/P
Reset			1	1	1	1	1	1
Bit	7	6	5	4	3	2	1	0
		RSTOSC[2:0]				FEXTOSC[2:0]		
Access	U	R/P	R/P	R/P	U	R/P	R/P	R/P
Reset	1	1	1	1	1	1	1	1

**Bit 13 – FCMEN** Fail-Safe Clock Monitor Enable bit

Value	Description
1	FSCM timer enabled
0	FSCM timer disabled

**Bit 11 – CSWEN** Clock Switch Enable bit

Value	Description
1	Writing to NOSC and NDIV is allowed
0	The NOSC and NDIV bits cannot be changed by user software

**Bit 8 – CLKOUTEN** Clock Out Enable bit

Value	Condition	Description
1	If <b>FEXTOSC</b> = EC (high, mid or low) or Not Enabled	CLKOUT function is disabled; I/O or oscillator function on OSC2
0	If <b>FEXTOSC</b> = EC (high, mid or low) or Not Enabled	CLKOUT function is enabled; F <sub>OSC</sub> /4 clock appears at OSC2
	Otherwise	This bit is ignored.

**Bits 6:4 – RSTOSC[2:0]** Power-up Default Value for COSC bits

This value is the Reset default value for COSC and selects the oscillator first used by user software. Refer to COSC operation.

Value	Description
111	EXTOSC operating per FEXTOSC bits
110	HFINTOSC (1 MHz), with OSCFRQ = '010' (4 MHz) and CDIV = '0010' (4:1)
101	LFINTOSC
100	SOSC
011	Reserved
010	EXTOSC with 4x PLL, with EXTOSC operating per FEXTOSC bits

Value	Description
001	HFINTOSC with 2x PLL (32 MHz), with OSCFRQ = '101' (16 MHz) and CDIV = '0000' (1:1)
000	HFINTOSC with OSCFRQ = 32 MHz and CDIV = 1:1

**Bits 2:0 – FEXTOSC[2:0]** FEXTOSC External Oscillator Mode Selection bits

Value	Description
111	ECH (External Clock) above 8 MHz
110	ECM (External Clock) for 500 kHz to 8 MHz
101	ECL (External Clock) below 500 kHz
100	Oscillator not enabled
011	Reserved (do not use)
010	HS (Crystal oscillator) above 4 MHz
001	XT (Crystal oscillator) above 100 kHz, below 4 MHz
000	LP (crystal oscillator) optimized for 32.768 kHz

**Related Links**

[9.6.7 OSCFRQ](#)

[9.6.2 OSCCON2](#)

#### 4.7.2 CONFIG2

**Name:** CONFIG2  
**Address:** 0x8008

Configuration Word 2

Supervisor

Bit	15	14	13	12	11	10	9	8
			DEBUG	STVREN	PPS1WAY	ZCD	BORV	
Access			R/P	R/P	R/P	R/P	R/P	U
Reset			1	1	1	1	1	1
Bit	7	6	5	4	3	2	1	0
	BOREN[1:0]		LPBOREN			PWRTS[1:0]		MCLRE
Access	R/P	R/P	R/P	U	U	R/P	R/P	R/P
Reset	1	1	1	1	1	1	1	1

**Bit 13 – DEBUG** Debugger Enable bit<sup>(1)</sup>

Value	Description
1	Background debugger disabled
0	Background debugger enabled

**Bit 12 – STVREN** Stack Overflow/Underflow Reset Enable bit

Value	Description
1	Stack Overflow or Underflow will cause a Reset
0	Stack Overflow or Underflow will not cause a Reset

**Bit 11 – PPS1WAY** PPSLOCKED bit One-Way Set Enable bit

Value	Description
1	The PPSLOCKED bit can be cleared and set only once; PPS registers remain locked after one clear/set cycle
0	The PPSLOCKED bit can be set and cleared repeatedly (subject to the unlock sequence)

**Bit 10 – ZCD** ZCD Control bit

Value	Description
1	ZCD disabled. ZCD can be enabled by setting the ZCDSEN bit of the ZCDCON register.
0	ZCD always enabled, ZCDSEN bit is ignored

**Bit 9 – BORV** Brown-out Reset Voltage Selection bit<sup>(2)</sup>

Value	Description
1	Brown-out Reset voltage ( $V_{BOR}$ ) set to lower trip point level
0	Brown-out Reset voltage ( $V_{BOR}$ ) set to higher trip point level

**Bits 7:6 – BOREN[1:0]** Brown-out Reset Enable bits

When enabled, Brown-out Reset Voltage ( $V_{BOR}$ ) is set by BORV bit

Value	Description
11	Brown-out Reset enabled, SBOREN bit is ignored
10	Brown-out Reset enabled while running, disabled in Sleep; SBOREN is ignored
01	Brown-out Reset enabled according to SBOREN
00	Brown-out Reset disabled

**Bit 5 – LPBOREN** Low-Power BOR Enable bit

Value	Description
1	Low-Power Brown-out Reset is disabled
0	Low-Power Brown-out Reset is enabled

**Bits 2:1 – PWRTS[1:0]** Power-up Timer Selection bits

Value	Description
11	PWRT disabled
10	PWRT set at 64 ms
01	PWRT set at 16 ms
00	PWRT set at 1 ms

**Bit 0 – MCLRE** Master Clear ( $\overline{\text{MCLR}}$ ) Enable bit

Value	Condition	Description
	If LVP = 1	RE3 pin function is $\overline{\text{MCLR}}$ (it will reset the device when driven low)
1	If LVP = 0	$\overline{\text{MCLR}}$ pin is $\overline{\text{MCLR}}$ (it will reset the device when driven low)
0	If LVP = 0	$\overline{\text{MCLR}}$ pin function is port defined function

**Note:**

1. The  $\overline{\text{DEBUG}}$  bit in Configuration Words is managed automatically by device development tools including debuggers and programmers. For normal device operation, this bit should be maintained as a '1'.
2. See  $V_{\text{BOR}}$  parameter in the “*Electrical Specifications*” chapter for specific trip point voltages.

**Related Links**

[42.4.5 Reset, WDT, Oscillator Start-up Timer, Power-up Timer, Brown-Out Reset and Low-Power Brown-Out Reset Specifications](#)

4.7.3 CONFIG3

Name: CONFIG3  
Address: 0x8009

Configuration Word 3

Windowed Watchdog Timer

Bit	15	14	13	12	11	10	9	8
			WDTCCS[2:0]			WDTCWS[2:0]		
Access			R/P	R/P	R/P	R/P	R/P	R/P
Reset			1	1	1	1	1	1
Bit	7	6	5	4	3	2	1	0
			WDTE[1:0]		WDTCPSC[4:0]			
Access	U	R/P	R/P	R/P	R/P	R/P	R/P	R/P
Reset	1	1	1	1	1	1	1	1

Bits 13:11 – WDTCCS[2:0] WDT Input Clock Selector bits

Value	Description
111	Software Control
110 to 011	Reserved
010	32 kHz SOSC
001	WDT reference clock is the 31.25 kHz HFINTOSC (MFINTOSC) output
000	WDT reference clock is the 31.0 kHz LFINTOSC

Bits 10:8 – WDTCWS[2:0] WDT Window Select bits

WDTCWS	WDTCON1 [WINDOW] at POR			Software control of WINDOW?	Keyed access required?
	Value	Window delay Percent of time	Window opening Percent of time		
111	111	n/a	100	Yes	No
110	110	n/a	100	No	Yes
101	101	25	75		
100	100	37.5	62.5		
011	011	50	50		
010	010	62.5	37.5		
001	001	75	25		
000	000	87.5	12.5		

Bits 6:5 – WDTE[1:0] WDT Operating Mode bits

Value	Description
11	WDT enabled regardless of Sleep; SEN is ignored
10	WDT enabled while Sleep = 0, suspended when Sleep = 1; SEN bit is ignored
01	WDT enabled/disabled by SEN bit
00	WDT disabled, SEN bit is ignored

**Bits 4:0 – WDTCP5[4:0]** WDT Period Select bits

WDTCP5	WDTCON0[WDTP5] at POR			Software Control of WDTP5?	
	Value	Divider Ratio	Typical Time Out ( $F_{IN} = 31 \text{ kHz}$ )		
11111	01011	1:65536	$2^{16}$	2s	Yes
11110	11110	1:32	$2^5$	1 ms	No
...	...				
10011	10011				
10010	10010	1:8388608	$2^{23}$	256s	No
10001	10001	1:4194304	$2^{22}$	128s	
10000	10000	1:2097152	$2^{21}$	64s	
01111	01111	1:1048576	$2^{20}$	32s	
01110	01110	1:524288	$2^{19}$	16s	
01101	01101	1:262144	$2^{18}$	8s	
01100	01100	1:131072	$2^{17}$	4s	
01011	01011	1:65536	$2^{16}$	2s	
01010	01010	1:32768	$2^{15}$	1s	
01001	01001	1:16384	$2^{14}$	512 ms	
01000	01000	1:8192	$2^{13}$	256 ms	
00111	00111	1:4096	$2^{12}$	128 ms	
00110	00110	1:2048	$2^{11}$	64 ms	
00101	00101	1:1024	$2^{10}$	32 ms	
00100	00100	1:512	$2^9$	16 ms	
00011	00011	1:256	$2^8$	8 ms	
00010	00010	1:128	$2^7$	4 ms	
00001	00001	1:64	$2^6$	2 ms	
00000	00000	1:32	$2^5$	1 ms	



4.7.4 CONFIG4

Name: CONFIG4  
Address: 0x800A

Configuration Word 4

Memory Write Protection

Bit	15	14	13	12	11	10	9	8
			LVP		WRTSAF	WRTD	WRTC	WRTB
Access			R/P	U	R/P	R/P	R/P	R/P
Reset			1	1	1	1	1	1
Bit	7	6	5	4	3	2	1	0
	WRTAPP			SAFEN	BBEN	BBSIZE[2:0]		
Access	R/P	U	U	R/P	R/P	R/P	R/P	R/P
Reset	1	1	1	1	1	1	1	1

**Bit 13 – LVP** Low-Voltage Programming Enable bit

The LVP bit cannot be written (to zero) while operating from the LVP programming interface. The purpose of this rule is to prevent the user from dropping out of LVP mode while programming from LVP mode, or accidentally eliminating LVP mode from the Configuration state.

The preconditioned (erased) state for this bit is critical.

Value	Description
1	Low-voltage programming enabled. MCLR/V <sub>PP</sub> pin function is MCLR. MCLRE Configuration bit is ignored.
0	HV on MCLR/V <sub>PP</sub> must be used for programming

**Bit 11 – WRTSAF** Storage Area Flash Write Protection bit<sup>(1)</sup>

Value	Description
1	SAF NOT write-protected
0	SAF write-protected

**Bit 10 – WRTD** Data EEPROM Write Protection bit<sup>(1)</sup>

Value	Description
1	Data EEPROM NOT write-protected
0	Data EEPROM write-protected

**Bit 9 – WRTC** Configuration Register Write Protection bit<sup>(1)</sup>

Value	Description
1	Configuration Registers NOT write-protected
0	Configuration Registers write-protected

**Bit 8 – WRTB** Boot Block Write Protection bit<sup>(1)</sup>

Value	Description
1	Boot Block NOT write-protected
0	Boot Block write-protected

**Bit 7 – WRTAPP** Application Block Write Protection bit<sup>(1)</sup>

Value	Description
1	Application Block NOT write-protected
0	Application Block write-protected

**Bit 4 – SAFEN** SAF Enable bit<sup>(1)</sup>

Value	Description
1	SAF disabled
0	SAF enabled

**Bit 3 – BBEN** Boot Block Enable bit<sup>(1)</sup>

Value	Description
1	Boot Block disabled
0	Boot Block enabled

**Bits 2:0 – BBSIZE[2:0]** Boot Block Size Selection bits

BBSIZE is used only when  $\overline{\text{BBEN}} = 0$

BBSIZE bits can only be written while  $\overline{\text{BBEN}} = 1$ ; after  $\overline{\text{BBEN}} = 0$ , BBSIZ is write-protected.

**Table 4-1. Boot Block Size Bits**

$\overline{\text{BBEN}}$	BBSIZE	Actual Boot Block Size User Program Memory Size (words)		Last Boot Block Memory Access
		PIC16(L)F18455	PIC16(L)F18456	
1	xxx	0	0	—
0	111	512	512	01FFh
0	110	1024	1024	03FFh
0	101	2048	2048	07FFh
0	100	4096	4096	0FFFh
0	011-000	—	8192	1FFFh

**Note:** The maximum boot block size is half the user program memory size. All selections higher than the maximum are set to half size. For example, all BBSIZE = 000 - 100 produce a boot block size of 4 kW on a 8 kW device.

**Note:**

- Bits are implemented as sticky bits. Once protection is enabled, it can only be reset through a Bulk Erase.

#### 4.7.5 CONFIG5

Name: CONFIG5  
Address: 0x800B

Configuration Word 5

Code Protection

Bit	15	14	13	12	11	10	9	8
Access			U	U	U	U	U	U
Reset			1	1	1	1	1	1
Bit	7	6	5	4	3	2	1	0
								$\overline{CP}$
Access	U	U	U	U	U	U	U	R/P
Reset	1	1	1	1	1	1	1	1

**Bit 0 –  $\overline{CP}$**  Program Flash Memory Code Protection bit

Value	Description
1	Program Flash Memory code protection disabled
0	Program Flash Memory code protection enabled

#### 4.8 Register Summary - Device and Revision

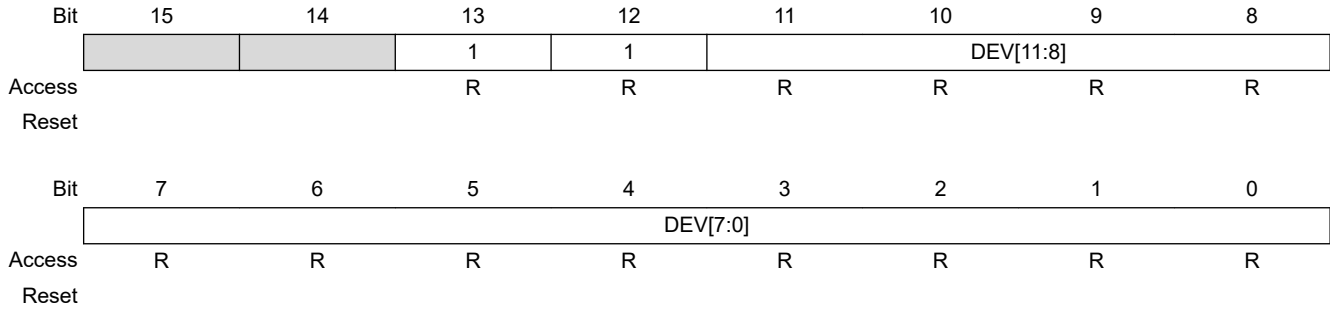
Offset	Name	Bit Pos.							
0x8005	REVISION ID	7:0	MJRREV[1:0]		MNRREV[5:0]				
		13:8		1	0	MJRREV[5:2]			
0x8006	DEVICE ID	7:0	DEV[7:0]						
		13:8	1	1	DEV[11:8]				

#### 4.9 Register Definitions: Device and Revision

**4.9.1 DEVICE ID**

**Name:** DEVICE ID  
**Address:** 0x8006

Device ID Register



**Bit 13 – 1**

These bit must be '1' to be distinguishable from the previous Device ID scheme

**Bit 12 – 1**

These bit must be '1' to be distinguishable from the previous Device ID scheme

**Bits 11:0 – DEV[11:0]**

Device ID bits

Device	Device ID
PIC16F18455	30D7h
PIC16LF18455	30D8h
PIC16F18456	30D9h
PIC16LF18456	30DAh

**4.9.2 REVISION ID**

**Name:** REVISION ID  
**Address:** 0x8005

Revision ID Register

	Bit	15	14	13	12	11	10	9	8
				1	0	MJRREV[5:2]			
Access				R	R	R	R	R	R
Reset				1	0				
	Bit	7	6	5	4	3	2	1	0
		MJRREV[1:0]			MNRREV[5:0]				
Access		R	R	R	R	R	R	R	R
Reset									

**Bit 13 – 1** Read as ‘1’  
 These bits are fixed with value ‘1’ for all devices in this family.

**Bit 12 – 0** Read as ‘0’  
 These bits are fixed with value ‘0’ for all devices in this family.

**Bits 11:6 – MJRREV[5:0]** Major Revision ID bits  
 These bits are used to identify a major revision.

**Bits 5:0 – MNRREV[5:0]** Minor Revision ID bits  
 These bits are used to identify a minor revision.

## 5. Device Information Area

The Device Information Area (DIA) is a dedicated region in the program memory space; it is a new feature in the PIC16(L)F184XX family of devices. The DIA contains the calibration data for the internal temperature indicator module, stores the Microchip Unique Identifier words, and the Fixed Voltage Reference voltage readings measured in mV. The complete DIA table is shown below, followed by a description of each region and its functionality. The data is mapped from 8100h to 811Fh in the PIC16(L)F184XX family. These locations are read-only and cannot be erased or modified. The data is programmed into the device during manufacturing.

**Table 5-1. Device Information Area**

Address Range	Name of Region	Standard Device Information
8100h-8108h	MUI0	Microchip Unique Identifier (9 Words)
	MUI1	
	MUI2	
	MUI3	
	MUI4	
	MUI5	
	MUI6	
	MUI7	
	MUI8	
8109h	MUI9	1 Word Reserved
810Ah-8111h	EUI0	Unassigned (8 Words)
	EUI1	
	EUI2	
	EUI3	
	EUI4	
	EUI5	
	EUI6	
	EUI7	
8112h	TSLR1	Unassigned (1 word)
8113h	TSLR2	Temperature indicator ADC reading at 90°C (low range setting)
8114h	TSLR3	Unassigned (1 word)
8115h	TSHR1	Unassigned (1 word)
8116h	TSHR2	Temperature indicator ADC reading at 90°C (high range setting)
8117h	TSHR3	Unassigned (1 word)

Address Range	Name of Region	Standard Device Information
8118h	FVRA1X	ADC FVR1 Output voltage for 1x setting (in mV)
8119h	FVRA2X	ADC FVR1 Output Voltage for 2x setting (in mV)
811Ah	FVRA4X <sup>(1)</sup>	ADC FVR1 Output Voltage for 4x setting (in mV)
811Bh	FVRC1X	Comparator FVR2 output voltage for 1x setting (in mV)
811Ch	FVRC2X	Comparator FVR2 output voltage for 2x setting (in mV)
811Dh	FVRC4X <sup>(1)</sup>	Comparator FVR2 output voltage for 4x setting (in mV)
811Eh-811Fh		Unassigned (2 Words)

**Note:**

1. Value not present on LF devices.

### 5.1 Microchip Unique Identifier (MUI)

The PIC16(L)F184XX devices are individually encoded during final manufacturing with a Microchip Unique Identifier (MUI). The MUI cannot be erased by a Bulk Erase command or any other user-accessible means. This feature allows for manufacturing traceability of Microchip Technology devices in applications where this is required. It may also be used by the application manufacturer for a number of functions that require unverified unique identification, such as:

- Tracking the device
- Unique serial number

The MUI consists of nine program words and one reserved program word. When taken together, these fields form a unique identifier. The MUI is stored in read-only locations, located between 8100h to 8109h in the DIA space. The above table lists the addresses of the identifier words.



**Important:** For applications that require verified unique identification, contact your Microchip Technology sales office to create a serialized quick turn programming option.

### 5.2 External Unique Identifier (EUI)

The EUI data is stored at locations 810Ah to 8111h in the program memory region. This region is an optional space for placing application specific information. The data is coded per customer requirements during manufacturing. The EUI cannot be erased by a Bulk Erase command.



**Important:** Data is stored in this address range on receiving a request from the customer. The customer may contact the local sales representative or Field Applications Engineer, and provide them the unique identifier information that is required to be stored in this region.

### 5.3 Analog-to-Digital Conversion Data of the Temperature Sensor

The purpose of the temperature indicator module is to provide a temperature-dependent voltage that can be measured by an analog module. The “*Temperature Indicator Module*” chapter explains the operation of the Temperature Indicator module and defines terms such as the low range and high range settings of the sensor. The DIA table contains the internal ADC measurement values of the temperature sensor for low and high range at fixed points of reference. The values are measured during test and are unique to each device. The right-justified ADC readings are stored in the DIA memory region. The calibration data can be used to plot the approximate sensor output voltage,  $V_{TSENSE}$  vs. Temperature curve.

- TSLR: Address 8112h to 8114h store the measurements for the low range setting of the temperature sensor at  $V_{DD} = 3V$ .
- TSHR: Address 8115h to 8117h store the measurements for the high range setting of the temperature sensor at  $V_{DD} = 3V$ .

The stored measurements are made by the device ADC using the internal  $V_{REF} = 2.048V$ .

#### Related Links

[19. Temperature Indicator Module](#)

### 5.4 Fixed Voltage Reference Data

The Fixed Voltage Reference, or FVR, is a stable voltage reference, independent of  $V_{DD}$ , with 1.024V, 2.048V or 4.096V selectable output levels. The output of the FVR can be configured to supply a reference voltage to the following:

- ADC input channel
- ADC positive reference
- Comparator positive input
- Digital-to-Analog Converter

For more information on the FVR, refer to the “*Fixed Voltage Reference (FVR)*” chapter (see related links).

The DIA stores measured FVR voltages for this device in mV for the different buffer settings of 1x, 2x or 4x at program memory locations 8118h to 811Dh.

- FVRA1X stores the value of ADC FVR1 Output voltage for 1x setting (in mV)
- FVRA2X stores the value of ADC FVR1 Output Voltage for 2x setting (in mV)
- FVRA4X stores the value of ADC FVR1 Output Voltage for 4x setting (in mV)
- FVRC1X stores the value of Comparator FVR2 output voltage for 1x setting (in mV)
- FVRC2X stores the value of Comparator FVR2 output voltage for 2x setting (in mV)
- FVRC4X stores the value of Comparator FVR2 output voltage for 4x setting (in mV)

#### Related Links

[18. \(FVR\) Fixed Voltage Reference](#)



## 6. Device Configuration Information

The Device Configuration Information (DCI) is a dedicated region in the program Flash memory mapped from 8200h to 821Fh. The data stored in the DCI memory is hard-coded into the device during manufacturing. Refer to the table below for the complete DCI table address and description. The DCI holds information about the device, which is useful for programming and bootloader applications. These locations are read-only and cannot be erased or modified.

**Table 6-1. Device Configuration Information for PIC16(L)F18455/56 Devices**

ADDRESS	Name	DESCRIPTION	PIC16(L)F18455/56	UNITS
8200h	ERSIZ	Erase Row Size	32	Words
8201h	WLSIZ	Number of Write Latches	32	Latches
8202h	URSIZ	Number of User Rows	256/512	Rows
8203h	EESIZ	EE Data Memory Size	256	Bytes
8204h	PCNT	Pin Count	28	Pins

### 6.1 DIA and DCI Access

The DIA and DCI data are read-only and cannot be erased or modified. See section “*NVMREG Access to Device Information Area, Device Configuration Area, User ID, Device ID, EEPROM, and Configuration Words*” for more information on accessing these memory locations.

Development tools, such as device programmers and debuggers, may be used to read the DIA and DCI regions, similar to the Device ID and Revision ID.

#### Related Links

[13.4.7 NVMREG Access to Device Information Area, Device Configuration Area, User ID, Device ID, EEPROM, and Configuration Words](#)

## 7. Memory Organization

These devices contain the following types of memory:

- Program Memory
  - Configuration Words
  - Device ID
  - User ID
  - Program Flash Memory
  - Device Information Area (DIA)
  - Device Configuration Information (DCI)
  - Revision ID
- Data Memory
  - Core Registers
  - Special Function Registers
  - General Purpose RAM
  - Common RAM
- EEPROM

The following features are associated with access and control of program memory and data memory:

- PCL and PCLATH
- Stack
- Indirect Addressing
- NVMREG access

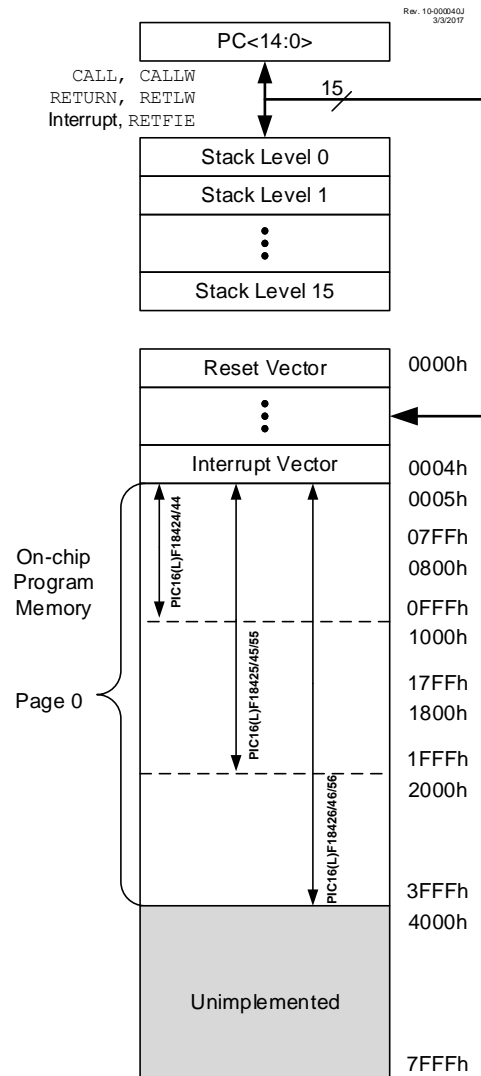
### 7.1 Program Memory Organization

The enhanced mid-range core has a 15-bit Program Counter capable of addressing 32K x 14 program memory space. The table below shows the memory sizes implemented. The Reset vector is at 0000h and the interrupt vector is at 0004h (see the following figure).

**Table 7-1. Device Sizes And Addresses**

Device	Program Memory Size (Words)	Last Program Memory Address
PIC16(L)F18455	8192	0x1FFF
PIC16(L)F18456	16384	0x3FFF

Figure 7-1. Program Memory and Stack



**Related Links**

[4.7.5 CONFIG5](#)

[7.2.5 Memory Violation](#)

**7.1.1 Reading Program Memory as Data**

There are three methods of accessing constants in program memory. The first method is to use tables of RETLW instructions. The second method is to set an FSR to point to the program memory. The third method is to use the NVMREG interface to access the program memory.

**Related Links**

[13.4 NVMREG Access](#)

### 7.1.1.1 RETLW Instruction

The RETLW instruction can be used to provide access to tables of constants. The recommended way to create such a table is shown in the following example.

```
constants
    BRW                ;Add Index in W to
                      ;program counter to
                      ;select data
    RETLW DATA0       ;Index0 data
    RETLW DATA1       ;Index1 data
    RETLW DATA2
    RETLW DATA3
my_function
;... LOTS OF CODE...
    MOVLW             DATA_INDEX
    call constants
;... THE CONSTANT IS IN W
```

The BRW instruction makes this type of table very simple to implement.

### 7.1.1.2 Indirect Read with FSR

The program memory can be accessed as data by setting bit 7 of an FSRxH register and reading the matching INDFx register. The MOVIW instruction will place the lower eight bits of the addressed word in the W register. Writes to the program memory cannot be performed via the INDFx registers. Instructions that read the program memory via the FSR require one extra instruction cycle to complete. The following example demonstrates reading the program memory via an FSR.

The HIGH directive will set bit 7 if a label points to a location in the program memory. This applies to the assembly code shown below.

```
constants
    RETLW DATA0       ;Index0 data
    RETLW DATA1       ;Index1 data
    RETLW DATA2
    RETLW DATA3
my_function
;... LOTS OF CODE...
    MOVLW             LOW constants
    MOVWF             FSR1L
    MOVLW             HIGH constants
    MOVWF             FSR1H
    MOVIW             2[FSR1
;DATA2 IS IN W
```

## 7.2 Memory Access Partition (MAP)

User Flash is partitioned into:

- Application Block
- Boot Block, and
- Storage Area Flash (SAF) Block

The user can allocate the memory usage by setting the  $\overline{\text{BBEN}}$  bit, selecting the size of the partition defined by BBSIZE bits and enabling the Storage Area Flash by the  $\overline{\text{SAFEN}}$  bit of the Configuration Word. Refer to the following links for the different user Flash memory partitions.

### Related Links

[4.7.4 CONFIG4](#)

**7.2.1 Application Block**

Default settings of the Configuration bits ( $\overline{\text{BBEN}} = 1$  and  $\overline{\text{SAFEN}} = 1$ ) assign all memory in the user Flash area to the application block.

**7.2.2 Boot Block**

If  $\overline{\text{BBEN}} = 1$ , the boot block is enabled and a specific address range is allotted as the boot block based on the value of the BBSIZE bits and the sizes provided in Configuration Word 4.

**Related Links**

[4.7.4 CONFIG4](#)

**7.2.3 Storage Area Flash**

Storage Area Flash (SAF) is enabled by clearing the  $\overline{\text{SAFEN}}$  bit of the Configuration Word. If enabled, the SAF block is placed at the end of memory and spans 128 words. If the Storage Area Flash (SAF) is enabled, the SAF area is not available for program execution.

**Related Links**

[4.7.4 CONFIG4](#)

**7.2.4 Memory Write Protection**

All the memory blocks have corresponding write-protection fuses  $\overline{\text{WRTAPP}}$ ,  $\overline{\text{WRTB}}$  and  $\overline{\text{WRTC}}$  bits in the Configuration Word 4. If write-protected locations are written from NVMCON registers, memory is not changed and the WRERR bit defined in NVMCON1 register is set as explained in the “*WRERR Bit*” section.

**Related Links**

[4.7.4 CONFIG4](#)

[13.6.3 NVMCON1](#)

[13.4.9 WRERR Bit](#)

**7.2.5 Memory Violation**

A Memory Execution Violation Reset occurs while executing an instruction that has been fetched from outside a valid execution area, clearing the  $\overline{\text{MEMV}}$  bit. Refer to the “*Memory Execution Violation*” section for the available valid program execution areas and the PCON1 register definition for  $\overline{\text{MEMV}}$  bit conditions.

**Table 7-2. Memory Access Partition**

REG	Address	Partition			
		$\overline{\text{BBEN}} = 1$ $\overline{\text{SAFEN}} = 1$	$\overline{\text{BBEN}} = 1$ $\overline{\text{SAFEN}} = 0$	$\overline{\text{BBEN}} = 0$ $\overline{\text{SAFEN}} = 1$	$\overline{\text{BBEN}} = 0$ $\overline{\text{SAFEN}} = 0$
PFM	00 0000h ... Last Block	APPLICATION BLOCK <sup>(4)</sup>	APPLICATION BLOCK <sup>(4)</sup>	BOOT BLOCK <sup>(4)</sup>	BOOT BLOCK <sup>(4)</sup>

REG	Address	Partition			
		$\overline{\text{BBEN}} = 1$ $\overline{\text{SAFEN}} = 1$	$\overline{\text{BBEN}} = 1$ $\overline{\text{SAFEN}} = 0$	$\overline{\text{BBEN}} = 0$ $\overline{\text{SAFEN}} = 1$	$\overline{\text{BBEN}} = 0$ $\overline{\text{SAFEN}} = 0$
	Memory Address				
	Last Boot Block Memory Address + 1 <sup>(1)</sup> ... Last Program Memory Address - 80h			APPLICATION BLOCK <sup>(4)</sup>	APPLICATION BLOCK <sup>(4)</sup>
	Last Program Memory Address - 7Fh <sup>(2)</sup> ... Last Program Memory Address		SAF <sup>(4)</sup>	APPLICATION BLOCK <sup>(4)</sup>	SAF <sup>(4)</sup>
CONFIG	Config Memory Address <sup>(3)</sup>	CONFIG			

**Note:**

1. Last Boot Block Memory Address is based on BBSIZE given in “*Configuration Word 4*”.
2. Last Program Memory Address is the Flash size given in the “*Program Memory Organization*”.
3. Config Memory Address are the address locations of the Configuration Words given in the “*NVMREG Access to Device Information Area, Device Configuration Area, User ID, Device ID, EEPROM, and Configuration Words*” section.
4. Each memory block has a corresponding write protection fuse defined by the  $\overline{\text{WRTAPP}}$ ,  $\overline{\text{WRTB}}$  and  $\overline{\text{WRTC}}$  bits in the “*Configuration Word 4*”.

**Related Links**

[8.11 Memory Execution Violation](#)

[8.15.3 PCON1](#)

[4.7.4 CONFIG4](#)

[7.1 Program Memory Organization](#)

[13.4.7 NVMREG Access to Device Information Area, Device Configuration Area, User ID, Device ID, EEPROM, and Configuration Words](#)

## 7.3 Data Memory Organization

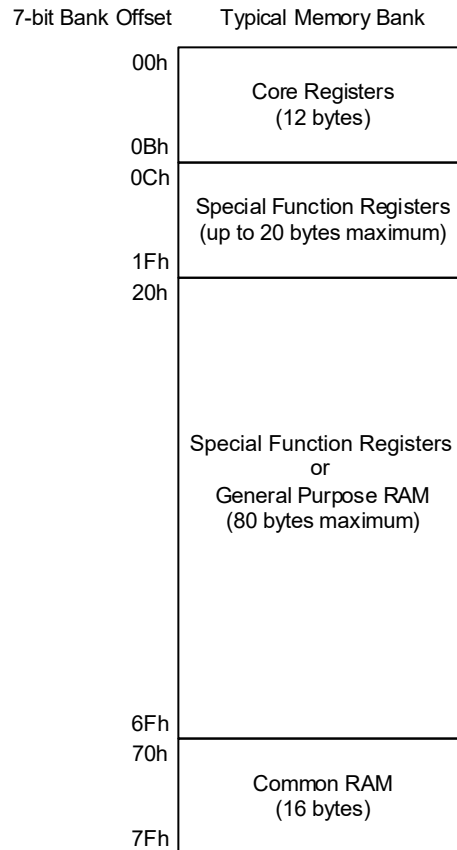
The data memory is partitioned into 64 memory banks with 128 bytes in each bank. Each bank consists of:

- 12 core registers
- Up to 100 Special Function Registers (SFR)

- Up to 80 bytes of General Purpose RAM (GPR)
- 16 bytes of common RAM

**Figure 7-2. Banked Memory Partition**

Rev. 10-000 041C  
 11/8/2017



### 7.3.1 Bank Selection

The active bank is selected by writing the bank number into the Bank Select Register (BSR). All data memory can be accessed either directly (via instructions that use the file registers) or indirectly via the two File Select Registers (FSR). Data memory uses a 13-bit address. The upper six bits of the address define the Bank address and the lower seven bits select the registers/RAM in that bank.

#### Related Links

[7.6 Indirect Addressing](#)

[7.8.7 BSR](#)

### 7.3.2 Core Registers

The core registers contain the registers that directly affect the basic operation. The core registers occupy the first 12 addresses of every data memory bank (addresses n00h/n80h through n0Bh/n8Bh). These registers are listed below.

Table 7-3. Core Registers

Addresses in BANKx	Core Registers
n00h or n80h	INDF0
n01h or n81h	INDF1
n02h or n82h	PCL
n03 or n83h	STATUS
n04h or n84h	FSR0L
n05h or n85h	FSR0H
n06h or n86h	FSR1L
n07h or n87h	FSR1H
n08h or n88h	BSR
n09h or n89h	WREG
n0Ah or n8Ah	PCLATH
n0Bh or n8Bh	INTCON

### 7.3.2.1 STATUS Register

The STATUS register contains:

- the arithmetic status of the ALU
- the Reset status

The STATUS register can be the destination for any instruction, like any other register. If the STATUS register is the destination for an instruction that affects the Z, DC or C bits, then the write to these three bits is disabled. These bits are set or cleared according to the device logic. Furthermore, the  $\overline{TO}$  and  $\overline{PD}$  bits are not writable. Therefore, the result of an instruction with the STATUS register as destination may be different than intended.

For example, `CLRF STATUS` will clear bits <4:3> and <1:0>, and set the Z bit. This leaves the STATUS register as '000u u1uu' (where u = unchanged).

It is recommended, therefore, that only `BCF`, `BSF`, `SWAPF` and `MOVWF` instructions are used to alter the STATUS register, because these instructions do not affect any Status bits. For other instructions not affecting any Status bits, refer to the “*Instruction Set Summary*” section.



**Important:** The C and DC bits operate as  $\overline{\text{Borrow}}$  and  $\overline{\text{Digit Borrow}}$  out bits, respectively, in subtraction.

### Related Links

[7.8.4 STATUS](#)



### **7.3.3 Special Function Register**

The Special Function Registers (SFR) are registers used by the application to control the desired operation of peripheral functions in the device. The SFRs occupy the first 20 bytes of the data banks 0-59 and the first 100 bytes of the data banks 60-63, after the core registers.

The SFRs associated with the operation of the peripherals are described in the appropriate peripheral chapter of this data sheet.

### **7.3.4 General Purpose RAM**

There are up to 80 bytes of GPR in each data memory bank.

#### **7.3.4.1 Linear Access to GPR**

The general purpose RAM can be accessed in a non-banked method via the FSRs. This can simplify access to large memory structures.

#### **Related Links**

[7.6.2 Linear Data Memory](#)

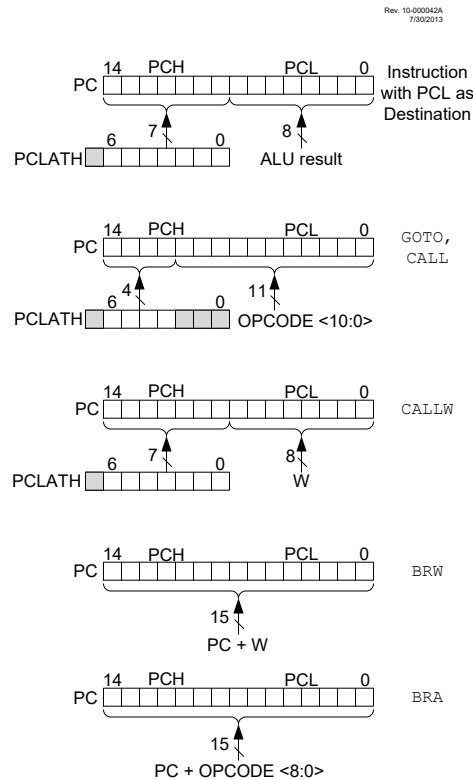
### **7.3.5 Common RAM**

There are 16 bytes of common RAM accessible from all banks.

## **7.4 PCL and PCLATH**

The Program Counter (PC) is 15 bits wide. The low byte comes from the PCL register, which is a readable and writable register. The high byte (PC<14:8>) is not directly readable or writable and comes from PCLATH. On any Reset, the PC is cleared. The following figure shows the five situations for the loading of the PC.

Figure 7-3. Loading of PC in Different Situations



### 7.4.1 Modifying PCL

Executing any instructions with the PCL register as the destination simultaneously causes the Program Counter PC<14:8> bits (PCH) to be replaced by the contents of the PCLATH register. This allows the entire contents of the Program Counter to be changed by writing the desired upper seven bits to the PCLATH register. When the lower eight bits are written to the PCL register, all 15 bits of the Program Counter will change to the values contained in the PCLATH register and those being written to the PCL register.

### 7.4.2 Computed GOTO

A computed `GOTO` is accomplished by adding an offset to the Program Counter (`ADDWF PCL`). When performing a table read using a computed `GOTO` method, care should be exercised if the table location crosses a PCL memory boundary (each 256-byte block). Refer to [Application Note AN556, "Implementing a Table Read"](#) (DS00556).

### 7.4.3 Computed Function Calls

A computed function `CALL` allows programs to maintain tables of functions and provide another way to execute state machines or look-up tables. When performing a table read using a computed function `CALL`, care should be exercised if the table location crosses a PCL memory boundary (each 256-byte block).

If using the `CALL` instruction, the PCH<2:0> and PCL registers are loaded with the operand of the `CALL` instruction. PCH<6:3> is loaded with PCLATH<6:3>.

The `CALLW` instruction enables computed calls by combining `PCLATH` and `W` to form the destination address. A computed `CALLW` is accomplished by loading the `W` register with the desired address and executing `CALLW`. The `PCL` register is loaded with the value of `W` and `PCH` is loaded with `PCLATH`.

#### 7.4.4 Branching

The branching instructions add an offset to the `PC`. This allows relocatable code and code that crosses page boundaries. There are two forms of branching, `BRW` and `BRA`. The `PC` will have incremented to fetch the next instruction in both cases. When using either branching instruction, a `PCL` memory boundary may be crossed.

If using `BRW`, load the `W` register with the desired unsigned address and execute `BRW`. The entire `PC` will be loaded with the address `PC + 1 + W`.

If using `BRA`, the entire `PC` will be loaded with `PC + 1 +` the signed value of the operand of the `BRA` instruction.

### 7.5 Stack

All devices have a 16-level by 15-bit wide hardware stack. The stack space is not part of either program or data space. The `PC` is `PUSHed` onto the stack when `CALL` or `CALLW` instructions are executed or an interrupt causes a branch. The stack is `POPed` in the event of a `RETURN`, `RETLW` or a `RETFIE` instruction execution. `PCLATH` is not affected by a `PUSH` or `POP` operation.

The stack operates as a circular buffer if the `STVREN` Configuration bit is programmed to '0'. This means that after the stack has been `PUSHed` sixteen times, the seventeenth `PUSH` overwrites the value that was stored from the first `PUSH`. The eighteenth `PUSH` overwrites the second `PUSH` (and so on). The `STKOVF` and `STKUNF` flag bits will be set on an Overflow/Underflow, regardless of whether the Reset is enabled.



**Important:** There are no instructions/mnemonics called `PUSH` or `POP`. These are actions that occur from the execution of the `CALL`, `CALLW`, `RETURN`, `RETLW` and `RETFIE` instructions or the vectoring to an interrupt address.

---

#### 7.5.1 Accessing the Stack

The stack is accessible through the `TOSH`, `TOSL` and `STKPTR` registers. `STKPTR` is the current value of the Stack Pointer. `TOSH:TOSL` register pair points to the `TOP` of the stack. Both registers are read/writable. `TOS` is split into `TOSH` and `TOSL` due to the 15-bit size of the `PC`. To access the stack, adjust the value of `STKPTR`, which will position `TOSH:TOSL`, then read/write to `TOSH:TOSL`. `STKPTR` is five bits to allow detection of overflow and underflow.



**Important:** Care should be taken when modifying the `STKPTR` while interrupts are enabled.

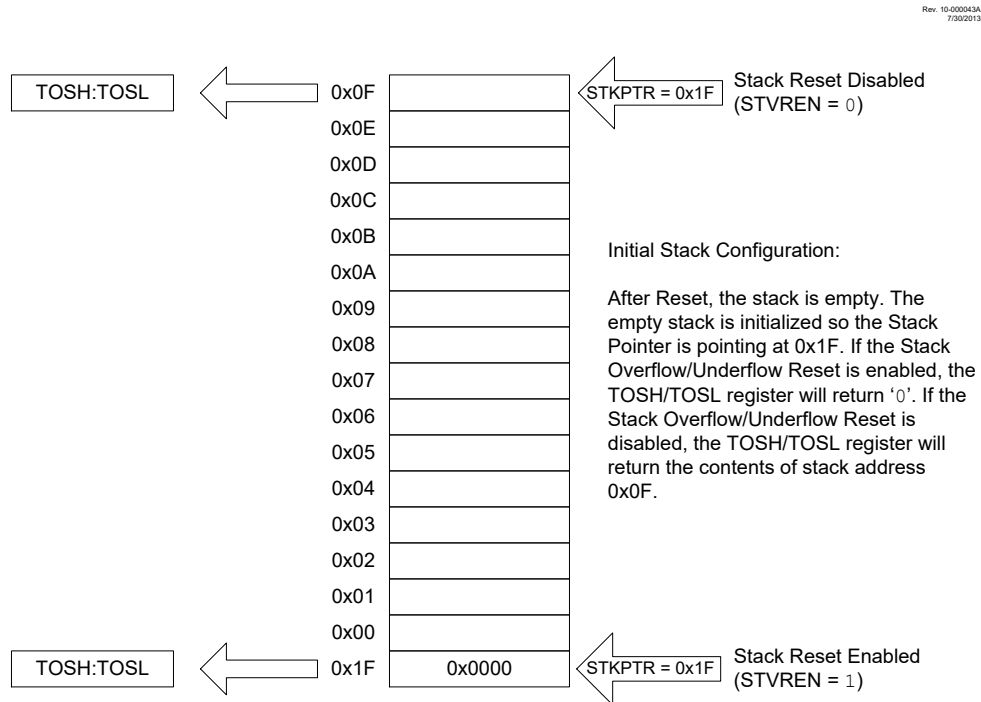
---

During normal program operation, `CALL`, `CALLW` and interrupts will increment `STKPTR` while `RETLW`, `RETURN`, and `RETFIE` will decrement `STKPTR`. `STKPTR` can be monitored to obtain to value of stack

memory left at any given time. The STKPTR always points at the currently used place on the stack. Therefore, a `CALL` or `CALLW` will increment the STKPTR and then write the PC, and a return will unload the PC value from the stack and then decrement the STKPTR.

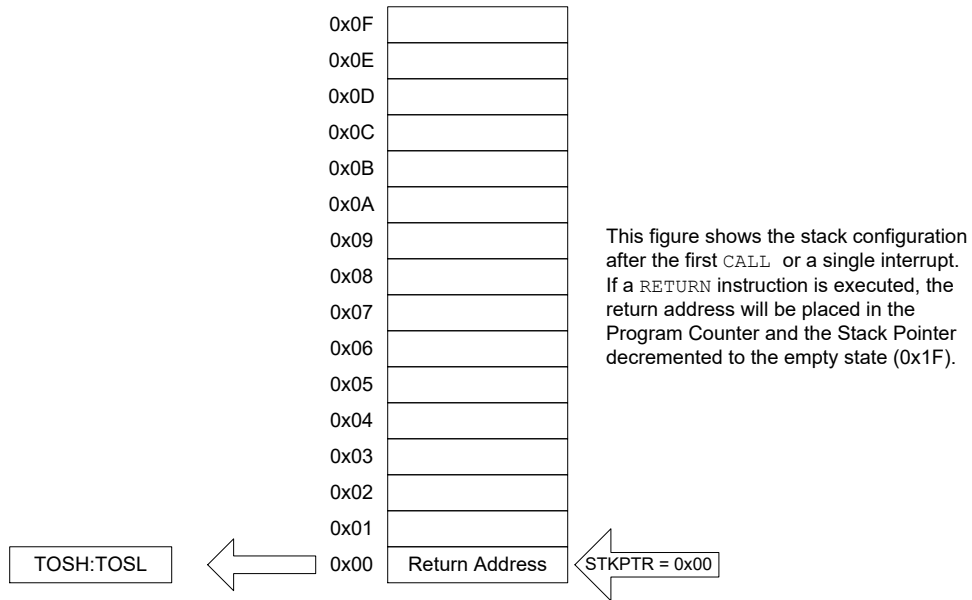
Reference the following figures for examples of accessing the stack.

**Figure 7-4. Accessing the Stack Example 1**



**Figure 7-5. Accessing the Stack Example 2**

Rev. 10-00043B  
7/30/2013



**Figure 7-6. Accessing the Stack Example 3**

Rev. 10-00043C  
7/30/2013

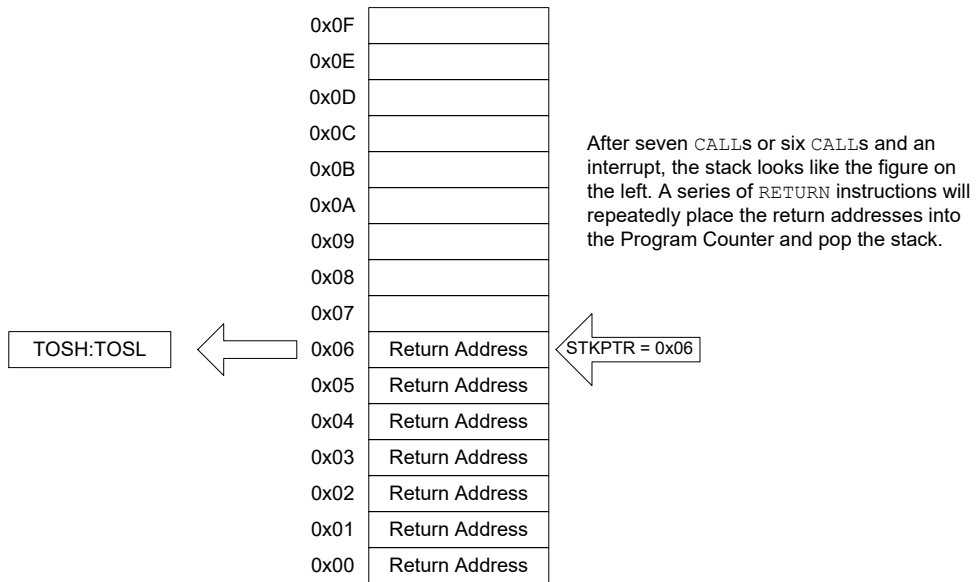
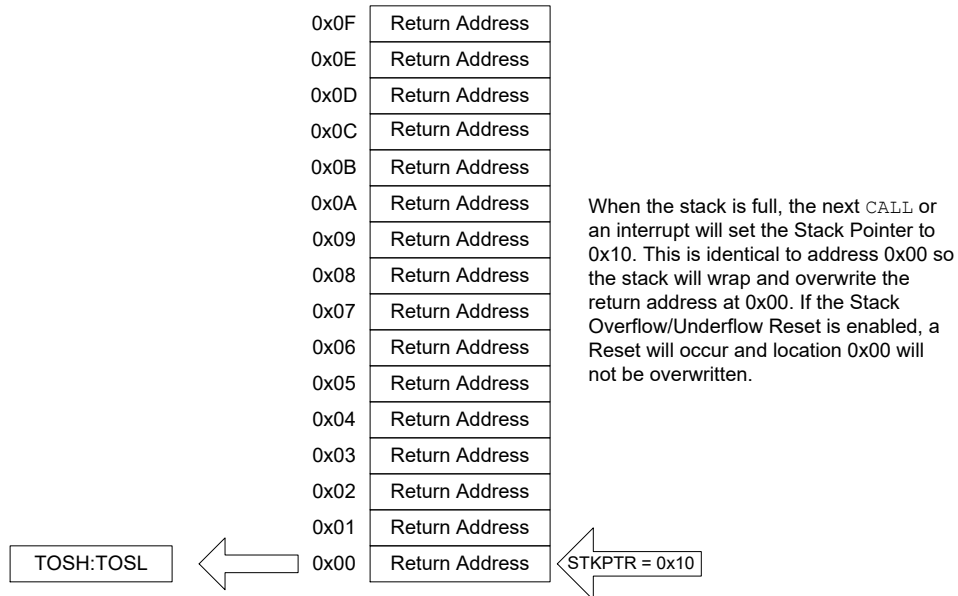


Figure 7-7. Accessing the Stack Example 4

Rev. 10-000043D  
7/30/2013



### Related Links

[7.8.11 TOS](#)

## 7.5.2 Overflow/Underflow Reset

If the STVREN bit in Configuration Word 2 is programmed to '1', the device will be Reset if the stack is PUSHed beyond the sixteenth level or POPed beyond the first level, setting the appropriate bits (STKOVF or STKUNF, respectively) in the PCON register.

### Related Links

[4.7.2 CONFIG2](#)

## 7.6 Indirect Addressing

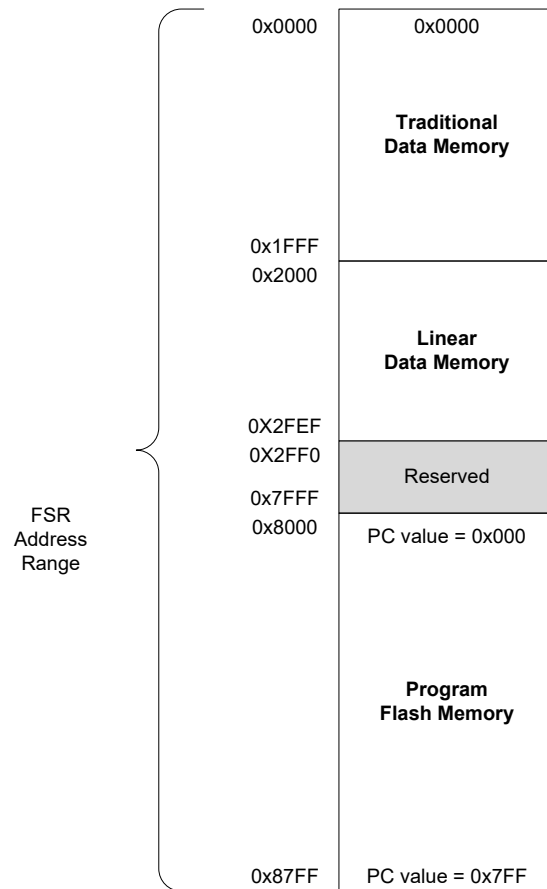
The INDFn registers are not physical registers. Any instruction that accesses an INDFn register actually accesses the register at the address specified by the File Select Registers (FSR). If the FSRn address specifies one of the two INDFn registers, the read will return '0' and the write will not occur (though Status bits may be affected). The FSRn register value is created by the pair FSRnH and FSRnL.

The FSR registers form a 16-bit address that allows an addressing space with 65536 locations. These locations are divided into three memory regions:

- Traditional/Banked Data Memory
- Linear Data Memory
- Program Flash Memory

Figure 7-8. Indirect Addressing PIC16(L)F18455/56

Rev. 10-000044F  
1/13/2017



### Related Links

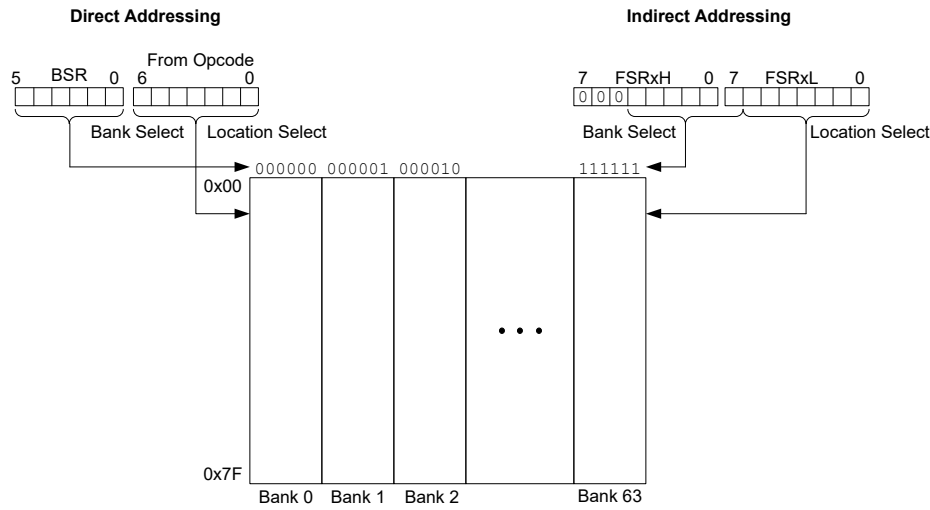
[7.8.5 FSR0](#)

#### 7.6.1 Traditional/Banked Data Memory

The traditional or banked data memory is a region from FSR address 0x000 to FSR address 0x1FFF. The addresses correspond to the absolute addresses of all SFR, GPR and common registers.

Figure 7-9. Traditional/Banked Data Memory Map

Rev. 10-000056B  
12/14/2016



## 7.6.2 Linear Data Memory

The linear data memory is the region from FSR address 0x2000 to FSR address 0x2FEF. This region is a virtual region that points back to the 80-byte blocks of GPR memory in all the banks. Refer to the following figure for the Linear Data Memory Map.



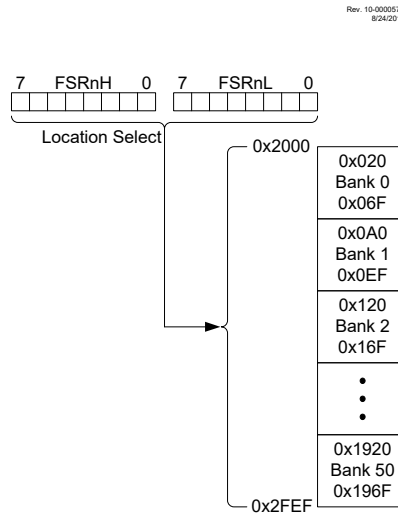
**Important:** The address range 0x2000 to 0x2FF0 represents the complete addressable Linear Data Memory up to Bank 50. The actual implemented Linear Data Memory will differ from one device to the other in a family. Confirm the memory limits on every device.

Unimplemented memory reads as 0x00. Use of the linear data memory region allows buffers to be larger than 80 bytes because incrementing the FSR beyond one bank will go directly to the GPR memory of the next bank.

The 16 bytes of common memory are not included in the linear data memory region.



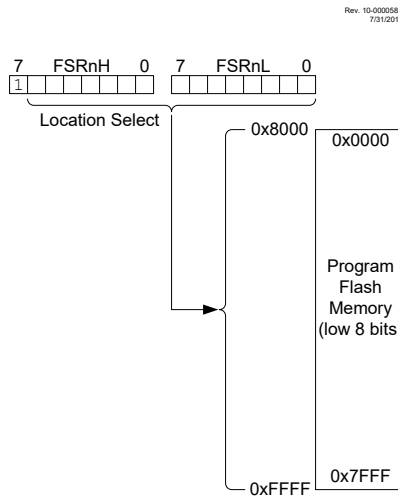
Figure 7-10. Linear Data Memory Map



### 7.6.3 Program Flash Memory

To make constant data access easier, the entire Program Flash Memory is mapped to the upper half of the FSR address space. When the MSB of FSRnH is set, the lower 15 bits are the address in program memory which will be accessed through INDF. Only the lower eight bits of each memory location are accessible via INDF. Writing to the Program Flash Memory cannot be accomplished via the FSR/INDF interface. All instructions that access Program Flash Memory via the FSR/INDF interface will require one additional instruction cycle to complete.

Figure 7-11. Program Flash Memory Map



## 7.7 Register Summary - Memory and Status

Offset	Name	Bit Pos.							
0x00	INDF0	7:0							INDF[7:0]
0x01	INDF1	7:0							INDF[7:0]

# PIC16(L)F18455/56

## Memory Organization

Offset	Name	Bit Pos.								
0x02	PCL	7:0	PCL[7:0]							
0x03	STATUS	7:0				T $\bar{O}$	PD	Z	DC	C
0x04	FSR0	7:0	FSRL[7:0]							
0x05		15:8	FSRH[7:0]							
0x06	FSR1	7:0	FSRL[7:0]							
0x07		15:8	FSRH[7:0]							
0x08	BSR	7:0			BSR[5:0]					
0x09	WREG	7:0	WREG[7:0]							
0x0A	PCLATH	7:0		PCLATH[6:0]						
0x0B	INTCON	7:0	GIE	PEIE						INTEDG
0x0C ... 0x0FEC	Reserved									
0x0FED	STKPTR	7:0				STKPTR[4:0]				
0x0FEE	TOS	7:0	TOSL[7:0]							
0x0FEF		15:8	TOSH[7:0]							

### 7.8 Register Definitions: Memory and Status

**7.8.1 INDF0**

**Name:** INDF0

**Address:** 0x00 + n\*0x80 [n=0..63]

Indirect Data Register. This is a virtual register. The GPR/SFR register addressed by the FSR0 register is the target for all operations involving the INDF0 register.

Bit	7	6	5	4	3	2	1	0
	INDF0[7:0]							
Access	R/W	R/W	R/W	R/W	R/W	R/W	R/W	R/W
Reset	0	0	0	0	0	0	0	0

**Bits 7:0 – INDF0[7:0]**

Indirect data pointed to by the FSR0 register

**Related Links**

[7.3.2 Core Registers](#)

**7.8.2 INDF1**

**Name:** INDF1

**Address:** 0x01 + n\*0x80 [n=0..63]

Indirect Data Register. This is a virtual register. The GPR/SFR register addressed by the FSR1 register is the target for all operations involving the INDF1 register.

Bit	7	6	5	4	3	2	1	0
	INDF1[7:0]							
Access	R/W	R/W	R/W	R/W	R/W	R/W	R/W	R/W
Reset	0	0	0	0	0	0	0	0

**Bits 7:0 – INDF1[7:0]**

Indirect data pointed to by the FSR1 register

**Related Links**

[7.3.2 Core Registers](#)

**7.8.3 PCL**

**Name:** PCL

**Address:** 0x02 + n\*0x80 [n=0..63]

Low byte of the Program Counter

Bit	7	6	5	4	3	2	1	0
	PCL[7:0]							
Access	R/W	R/W	R/W	R/W	R/W	R/W	R/W	R/W
Reset	0	0	0	0	0	0	0	0

**Bits 7:0 – PCL[7:0]**

Provides direct read and write access to the Program Counter

7.8.4 STATUS

**Name:** STATUS  
**Address:** 0x03 + n\*0x80 [n=0..63]

Status Register

Bit	7	6	5	4	3	2	1	0
				$\overline{TO}$	$\overline{PD}$	Z	DC	C
Access				RO	RO	R/W	R/W	R/W
Reset				1	1	0	0	0

**Bit 4 –  $\overline{TO}$**  Time-Out bit  
Reset States: POR/BOR = 1  
All Other Resets = q

Value	Description
1	Set at power-up or by execution of CLRWDT or SLEEP instruction
0	A WDT time-out occurred

**Bit 3 –  $\overline{PD}$**  Power-Down bit  
Reset States: POR/BOR = 1  
All Other Resets = q

Value	Description
1	Set at power-up or by execution of CLRWDT instruction
0	Cleared by execution of the SLEEP instruction

**Bit 2 – Z** Zero bit  
Reset States: POR/BOR = 0  
All Other Resets = u

Value	Description
1	The result of an arithmetic or logic operation is zero
0	The result of an arithmetic or logic operation is not zero

**Bit 1 – DC** Digit Carry/Borrow bit<sup>(1)</sup>  
ADDWF, ADDLW, SUBLW, SUBWF instructions  
Reset States: POR/BOR = 0  
All Other Resets = u

Value	Description
1	A carry-out from the 4th low-order bit of the result occurred
0	No carry-out from the 4th low-order bit of the result

**Bit 0 – C** Carry/Borrow bit<sup>(1)</sup>  
ADDWF, ADDLW, SUBLW, SUBWF instructions  
Reset States: POR/BOR = 0  
All Other Resets = u

---

---

Value	Description
1	A carry-out from the Most Significant bit of the result occurred
0	No carry-out from the Most Significant bit of the result occurred

**Note:**

1. For  $\overline{\text{Borrow}}$ , the polarity is reversed. A subtraction is executed by adding the two's complement of the second operand. For Rotate ( $\text{RRCF}$ ,  $\text{RLCF}$ ) instructions, this bit is loaded with either the high or low-order bit of the Source register.

**Related Links**

[7.3.2 Core Registers](#)

**7.8.5 FSR0**

**Name:** FSR0

**Address:** 0x04 + n\*0x80 [n=0..63]

Indirect Address Register. The FSR value is the address of the data to which the INDF register points.

Bit	15	14	13	12	11	10	9	8
FSRH[7:0]								
Access	R/W	R/W	R/W	R/W	R/W	R/W	R/W	R/W
Reset	0	0	0	0	0	0	0	0
Bit	7	6	5	4	3	2	1	0
FSRL[7:0]								
Access	R/W	R/W	R/W	R/W	R/W	R/W	R/W	R/W
Reset	0	0	0	0	0	0	0	0

**Bits 15:8 – FSRH[7:0]**

Most Significant address of INDF data

**Bits 7:0 – FSRL[7:0]**

Least Significant address of INDF data

**Related Links**

[7.3.2 Core Registers](#)



**7.8.6 FSR1**

**Name:** FSR1

**Address:** 0x06 + n\*0x80 [n=0..63]

Indirect Address Register. The FSR value is the address of the data to which the INDF register points.

	Bit	15	14	13	12	11	10	9	8
		FSRH[7:0]							
Access		R/W	R/W	R/W	R/W	R/W	R/W	R/W	R/W
Reset		0	0	0	0	0	0	0	0
	Bit	7	6	5	4	3	2	1	0
		FSRL[7:0]							
Access		R/W	R/W	R/W	R/W	R/W	R/W	R/W	R/W
Reset		0	0	0	0	0	0	0	0

**Bits 15:8 – FSRH[7:0]**

Most Significant address of INDF data

**Bits 7:0 – FSRL[7:0]**

Least Significant address of INDF data

**7.8.7 BSR**

**Name:** BSR

**Address:** 0x08 + n\*0x80 [n=0..63]

**Bank Select Register**

The BSR indicates the data memory bank by writing the bank number into the register. All data memory can be accessed directly via instructions, or indirectly via FSRs.

	7	6	5	4	3	2	1	0
			BSR[5:0]					
Access			R/W	R/W	R/W	R/W	R/W	R/W
Reset			0	0	0	0	0	0

**Bits 5:0 – BSR[5:0]**

Six Most Significant bits of the data memory address

**Related Links**

[7.3.2 Core Registers](#)

**7.8.8 WREG**

**Name:** WREG

**Address:** 0x09 + n\*0x80 [n=0..63]

Working Data Register

Bit	7	6	5	4	3	2	1	0
	WREG[7:0]							
Access	R/W	R/W	R/W	R/W	R/W	R/W	R/W	R/W
Reset	0	0	0	0	0	0	0	0

**Bits 7:0 – WREG[7:0]**

**Related Links**

[7.3.2 Core Registers](#)

7.8.9 PCLATH

**Name:** PCLATH

**Address:** 0x0A + n\*0x80 [n=0..63]

Program Counter Latches.

Write Buffer for the upper 7 bits of the Program Counter

Bit	7	6	5	4	3	2	1	0
	PCLATH[6:0]							
Access		R/W	R/W	R/W	R/W	R/W	R/W	R/W
Reset		0	0	0	0	0	0	0

**Bits 6:0 – PCLATH[6:0]** High PC Latch register  
Holding register for Program Counter bits <6:0>

**Related Links**

[7.3.2 Core Registers](#)

7.8.10 INTCON

**Name:** INTCON  
**Address:** 0x0B + n\*0x80 [n=0..63]

Interrupt Control Register

Bit	7	6	5	4	3	2	1	0
	GIE	PEIE						INTEDG
Access	R/W	R/W						R/W
Reset	0	0						1

**Bit 7 – GIE** Global Interrupt Enable bit

Value	Description
1	Enables all active interrupts
0	Disables all interrupts

**Bit 6 – PEIE** Peripheral Interrupt Enable bit

Value	Description
1	Enables all active peripheral interrupts
0	Disables all peripheral interrupts

**Bit 0 – INTEDG** External Interrupt Edge Select bit

Value	Description
1	Interrupt on rising edge of INT pin
0	Interrupt on falling edge of INT pin

**Important:** Interrupt flag bits are set when an interrupt condition occurs, regardless of the state of its corresponding enable bit or the global enable bit. User software should ensure the appropriate interrupt flag bits are clear prior to enabling an interrupt. This feature allows for software polling.

**Related Links**

[7.3.2 Core Registers](#)

**7.8.11 TOS**

**Name:** TOS  
**Address:** 0x1FEE

**Top-of-Stack Registers**

Contents of the stack pointed to by the STKPTR register. To access the stack, adjust the value of STKPTR, which will position TOSH:TOSL, then read/write to TOSH:TOSL.

Bit	15	14	13	12	11	10	9	8
	TOSH[7:0]							
Access	R/W	R/W	R/W	R/W	R/W	R/W	R/W	R/W
Reset	0	0	0	0	0	0	0	0
Bit	7	6	5	4	3	2	1	0
	TOSL[7:0]							
Access	R/W	R/W	R/W	R/W	R/W	R/W	R/W	R/W
Reset	0	0	0	0	0	0	0	0

**Bits 15:8 – TOSH[7:0]** High Byte of the TOS Register  
 Bits <15:8> of the TOS

**Bits 7:0 – TOSL[7:0]** Low Byte TOS Register  
 Bits <7:0> of the TOS

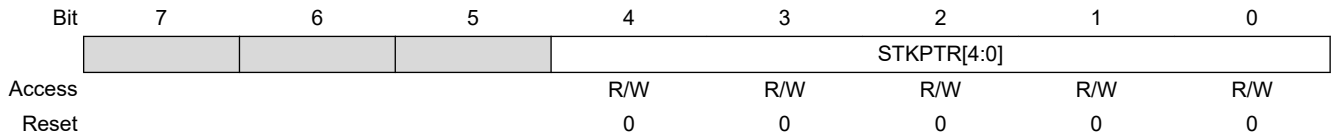
**Related Links**

[7.3.2 Core Registers](#)

**7.8.12 STKPTR**

**Name:** STKPTR  
**Address:** 0x1FED

Stack Pointer Register



**Bits 4:0 – STKPTR[4:0]** Stack Pointer Location bits

## 7.9 Register Summary: Shadow Registers

Address	Name	Bit Pos.									
0x1FE4	STATUS_SHAD	7:0				T $\bar{O}$	P $\bar{D}$	Z	DC	C	
0x1FE5	WREG_SHAD	7:0	WREG[7:0]								
0x1FE6	BSR_SHAD	7:0			BSR[5:0]						
0x1FE7	PCLATH_SHAD	7:0		PCLATH[6:0]							
0x1FE8	FSR0_SHAD	7:0	FSRL[7:0]								
		15:8	FSRH[7:0]								
0x1FEA	FSR1_SHAD	7:0	FSRL[7:0]								
		15:8	FSRH[7:0]								

## 7.10 Register Definitions: Shadow Registers



7.10.1 STATUS\_SHAD

Name: STATUS\_SHAD  
Address: 0x1FE4

Shadow of Status Register

Bit	7	6	5	4	3	2	1	0
				$\overline{\text{TO}}$	$\overline{\text{PD}}$	Z	DC	C
Access				RO	RO	R/W	R/W	R/W
Reset				x	x	x	x	x

**Bit 4 –  $\overline{\text{TO}}$**  Time-Out bit  
Reset States: POR/BOR = x  
All Other Resets = u

Value	Description
1	Set at power-up or by execution of CLRWDT or SLEEP instruction
0	A WDT time-out occurred

**Bit 3 –  $\overline{\text{PD}}$**  Power-Down bit  
Reset States: POR/BOR = x  
All Other Resets = u

Value	Description
1	Set at power-up or by execution of CLRWDT instruction
0	Cleared by execution of the SLEEP instruction

**Bit 2 – Z** Zero bit  
Reset States: POR/BOR = x  
All Other Resets = u

Value	Description
1	The result of an arithmetic or logic operation is zero
0	The result of an arithmetic or logic operation is not zero

**Bit 1 – DC** Digit Carry/Borrow bit<sup>(1)</sup>  
ADDWF, ADDLW, SUBLW, SUBWF instructions  
Reset States: POR/BOR = x  
All Other Resets = u

Value	Description
1	A carry-out from the 4th low-order bit of the result occurred
0	No carry-out from the 4th low-order bit of the result

**Bit 0 – C** Carry/Borrow bit<sup>(1)</sup>  
ADDWF, ADDLW, SUBLW, SUBWF instructions  
Reset States: POR/BOR = x  
All Other Resets = u

---

---

<b>Value</b>	<b>Description</b>
1	A carry-out from the Most Significant bit of the result occurred
0	No carry-out from the Most Significant bit of the result occurred

**Note:**

1. For  $\overline{\text{Borrow}}$ , the polarity is reversed. A subtraction is executed by adding the two's complement of the second operand. For Rotate ( $\text{RRCF}$ ,  $\text{RLCF}$ ) instructions, this bit is loaded with either the high or low-order bit of the Source register.

**7.10.2 WREG\_SHAD**

**Name:** WREG\_SHAD  
**Address:** 0x1FE5

Shadow of Working Data Register

Bit	7	6	5	4	3	2	1	0
	WREG[7:0]							
Access	R/W	R/W	R/W	R/W	R/W	R/W	R/W	R/W
Reset	x	x	x	x	x	x	x	x

**Bits 7:0 – WREG[7:0]**

Reset States: POR/BOR = xxxxxxxx  
 All Other Resets = uuuuuuuu

**7.10.3 BSR\_SHAD**

**Name:** BSR\_SHAD  
**Address:** 0x1FE6

Shadow of Bank Select Register

The BSR indicates the data memory bank by writing the bank number into the register. All data memory can be accessed directly via instructions, or indirectly via FSRs.

	7	6	5	4	3	2	1	0
			BSR[5:0]					
Access			R/W	R/W	R/W	R/W	R/W	R/W
Reset			x	x	x	x	x	x

**Bits 5:0 – BSR[5:0]**

Six Most Significant bits of the data memory address

Reset States: POR/BOR = xxxxxx

All Other Resets = uuuuuu

7.10.4 PCLATH\_SHAD

**Name:** PCLATH\_SHAD  
**Address:** 0x1FE7

Shadow of Program Counter Latches.

Write Buffer for the upper 7 bits of the Program Counter

Bit	7	6	5	4	3	2	1	0
	PCLATH[6:0]							
Access		R/W	R/W	R/W	R/W	R/W	R/W	R/W
Reset		x	x	x	x	x	x	x

**Bits 6:0 – PCLATH[6:0]** High PC Latch register  
Holding register for Program Counter bits <6:0>  
Reset States: POR/BOR = xxxxxxx  
All Other Resets = uuuuuuu

**7.10.5 FSR\_SHAD**

**Name:** FSRx\_SHAD  
**Address:** 0x1FE8,0x1FEA

Shadow of Indirect Address Register. The FSR value is the address of the data to which the INDF register points.

	Bit	15	14	13	12	11	10	9	8
		FSRH[7:0]							
Access		R/W	R/W	R/W	R/W	R/W	R/W	R/W	R/W
Reset		x	x	x	x	x	x	x	x
	Bit	7	6	5	4	3	2	1	0
		FSRL[7:0]							
Access		R/W	R/W	R/W	R/W	R/W	R/W	R/W	R/W
Reset		x	x	x	x	x	x	x	x

**Bits 15:8 – FSRH[7:0]**

Most Significant address of INDF data  
 Reset States: POR/BOR = xxxxxxxx  
                   All Other Resets = uuuuuuuu

**Bits 7:0 – FSRL[7:0]**

Least Significant address of INDF data  
 Reset States: POR/BOR = xxxxxxxx  
                   All Other Resets = uuuuuuuu

## 8. Resets

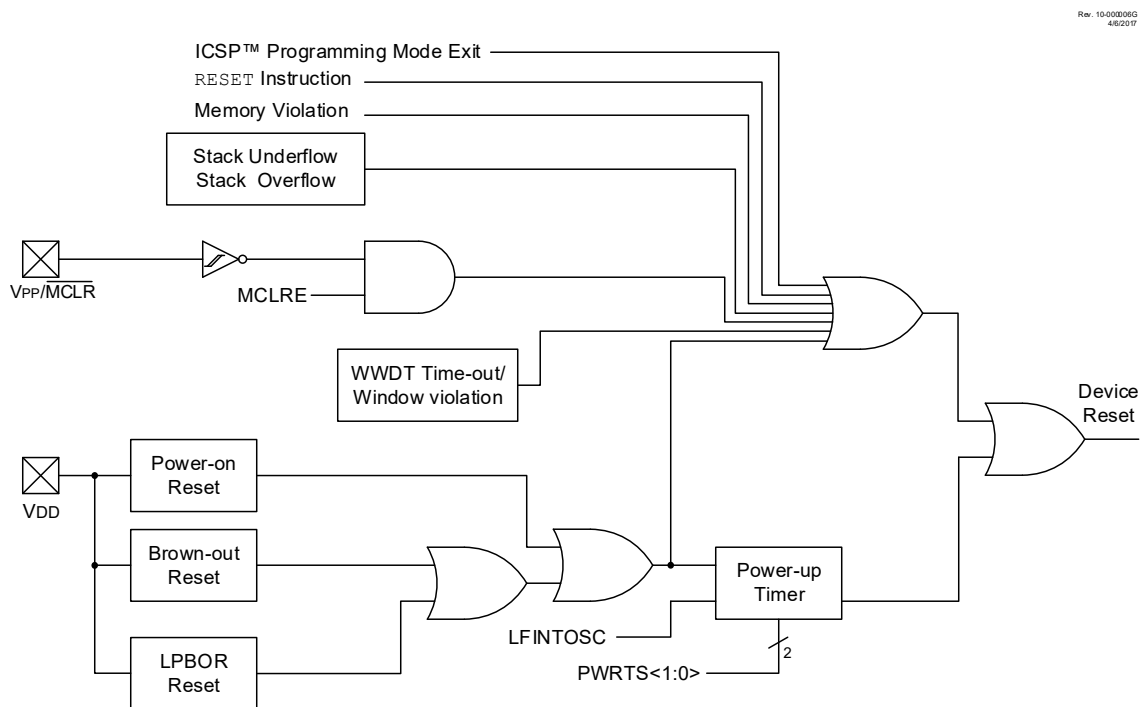
There are multiple ways to reset this device:

- Power-on Reset (POR)
- Brown-out Reset (BOR)
- Low-Power Brown-out Reset (LPBOR)
- $\overline{\text{MCLR}}$  Reset
- WDT Reset
- RESET instruction
- Stack Overflow
- Stack Underflow
- Programming mode exit

To allow  $V_{DD}$  to stabilize, an optional Power-up Timer can be enabled to extend the Reset time after a BOR or POR event.

A simplified block diagram of the On-Chip Reset Circuit is shown in the block diagram below.

**Figure 8-1. Simplified Block Diagram of On-Chip Reset Circuit**



**Note:** See “BOR Operating Conditions” table for BOR active conditions.

### Related Links

[8.2.3 BOR Controlled by Software](#)

## 8.1 Power-on Reset (POR)

The POR circuit holds the device in Reset until  $V_{DD}$  has reached an acceptable level for minimum operation. Slow rising  $V_{DD}$ , fast operating speeds or analog performance may require greater than minimum  $V_{DD}$ . The PWRT, BOR or MCLR features can be used to extend the start-up period until all device operation conditions have been met.

### Related Links

[8.2.3 BOR Controlled by Software](#)

## 8.2 Brown-out Reset (BOR)

The BOR circuit holds the device in Reset when  $V_{DD}$  reaches a selectable minimum level. Between the POR and BOR, complete voltage range coverage for execution protection can be implemented.

The Brown-out Reset module has four operating modes controlled by the BOREN<1:0> bits in Configuration Words. The four operating modes are:

- BOR is always on
- BOR is off when in Sleep
- BOR is controlled by software
- BOR is always off

Refer to “BOR Operating Conditions” table for more information.

The Brown-out Reset voltage level is selectable by configuring the BORV<1:0> bits in Configuration Words.

A  $V_{DD}$  noise rejection filter prevents the BOR from triggering on small events. If  $V_{DD}$  falls below  $V_{BOR}$  for a duration greater than parameter  $T_{BORDC}$ , the device will reset.

### 8.2.1 BOR is Always On

When the BOREN bits of Configuration Words are programmed to ‘11’, the BOR is always on. The device start-up will be delayed until the BOR is ready and  $V_{DD}$  is higher than the BOR threshold.

BOR protection is active during Sleep. The BOR does not delay wake-up from Sleep.

### 8.2.2 BOR is OFF in Sleep

When the BOREN bits of Configuration Words are programmed to ‘10’, the BOR is on, except in Sleep. The device start-up will be delayed until the BOR is ready and  $V_{DD}$  is higher than the BOR threshold.

BOR protection is not active during Sleep. The device wake-up will be delayed until the BOR is ready.

### 8.2.3 BOR Controlled by Software

When the BOREN bits of Configuration Words are programmed to ‘01’, the BOR is controlled by the [SBOREN](#) bit. The device start-up is not delayed by the BOR ready condition or the  $V_{DD}$  level.

BOR protection begins as soon as the BOR circuit is ready. The status of the BOR circuit is reflected in the [BORRDY](#) bit.

BOR protection is unchanged by Sleep.



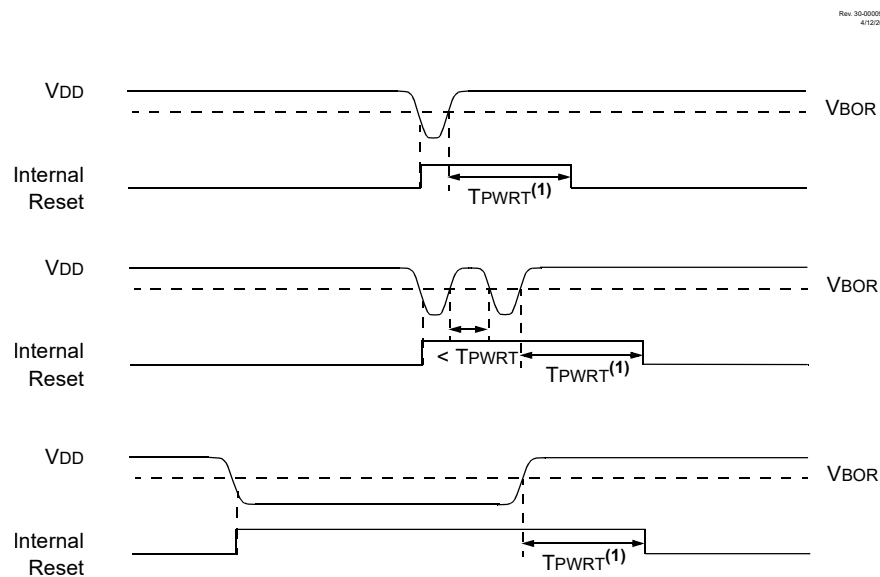
**Table 8-1. BOR Operating Conditions**

BOREN<1:0>	SBOREN	Device Mode	BOR Mode	Instruction Execution upon: Release of POR or Wake-up from Sleep
11	X	X	Active	Waits for release of BOR <sup>(1)</sup> (BORRDY = 1)
10	X	Awake	Active	Waits for release of BOR (BORRDY = 1) Waits for BOR Reset release
		Sleep	Disabled	
01	1	X	Active	Waits for BOR Reset release (BORRDY = 1)
	0	X	Disabled	
00	X	X	Disabled	Begins immediately (BORRDY = x)

**Note:**

1. In this specific case, “Release of POR” and “Wake-up from Sleep”, there is no delay in start-up. The BOR ready flag, (BORRDY = 1), will be set before the CPU is ready to execute instructions because the BOR circuit is forced on by the BOREN<1:0> bits

**Figure 8-2. Brown-out Situations**



**Note:**  $T_{PWRT}$  delay only if PWRTS bit field is programmed to a value different from ‘11’.

**8.2.4 BOR is Always OFF**

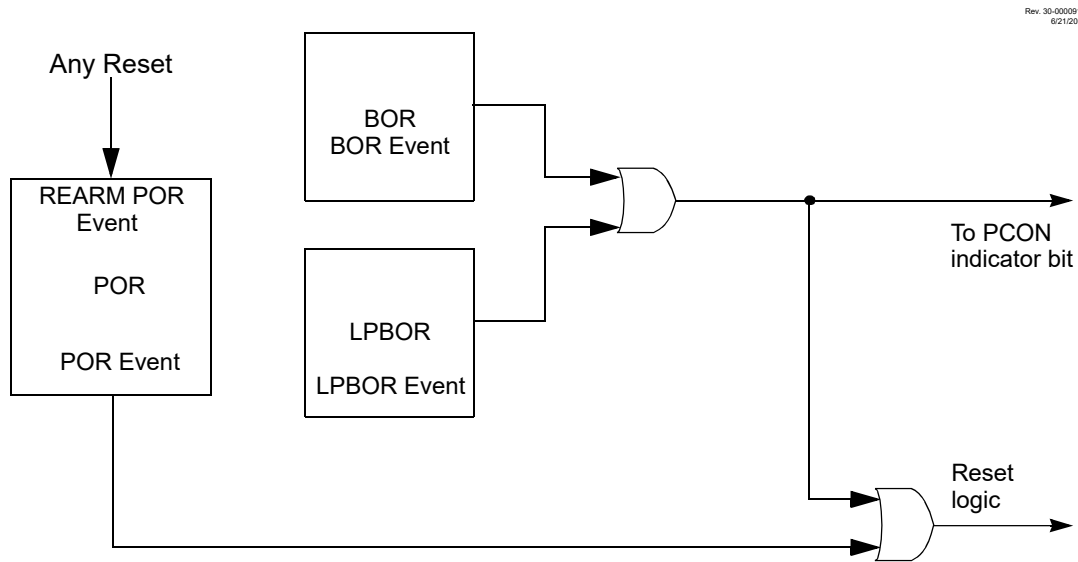
When the BOREN bits of the Configuration Words are programmed to ‘00’, the BOR is off at all times. The device start-up is not delayed by the BOR ready condition or the  $V_{DD}$  level.

**8.3 Low-Power Brown-out Reset (LPBOR)**

The Low-Power Brown-out Reset (LPBOR) provides an additional BOR circuit for low-power operation. Refer to the figure below to see how the BOR interacts with other modules.

The LPBOR is used to monitor the external  $V_{DD}$  pin. When too low of a voltage is detected, the device is held in Reset.

Figure 8-3. LPBOR, BOR, POR Relationship



### 8.3.1 Enabling LPBOR

The LPBOR is controlled by the  $\overline{\text{LPBOREN}}$  bit of Configuration Word 2. When the device is erased, the LPBOR module defaults to disabled.

#### Related Links

[4.7.2 CONFIG2](#)

### 8.3.2 LPBOR Module Output

The output of the LPBOR module is a signal indicating whether or not a Reset is to be asserted. This signal is OR'd together with the Reset signal of the BOR module to provide the generic  $\overline{\text{BOR}}$  signal, which goes to the [PCON0](#) register and to the power control block.

## 8.4 $\overline{\text{MCLR}}$ Reset

The  $\overline{\text{MCLR}}$  is an optional external input that can reset the device. The  $\overline{\text{MCLR}}$  function is controlled by the  $\overline{\text{MCLRE}}$  bit of Configuration Words and the  $\overline{\text{LVP}}$  bit of Configuration Words (see table below). The  $\overline{\text{RMCLR}}$  bit in the [PCON0](#) register will be set to '0' if a  $\overline{\text{MCLR}}$  has occurred.

Table 8-2.  $\overline{\text{MCLR}}$  Configuration

MCLRE	LVP	$\overline{\text{MCLR}}$
x	1	Enabled
1	0	Enabled
0	0	Disabled

### 8.4.1 MCLR Enabled

When  $\overline{\text{MCLR}}$  is enabled and the pin is held low, the device is held in Reset. The  $\overline{\text{MCLR}}$  pin is connected to  $V_{DD}$  through an internal weak pull-up.

The device has a noise filter in the  $\overline{\text{MCLR}}$  Reset path. The filter will detect and ignore small pulses.



**Important:** An internal Reset event (`RESET` instruction, BOR, WWDT, POR, STKOVF, STKUNF) does not drive the  $\overline{\text{MCLR}}$  pin low.

#### Related Links

[2.3 Master Clear \(MCLR\) Pin](#)

### 8.4.2 MCLR Disabled

When  $\overline{\text{MCLR}}$  is disabled, the  $\overline{\text{MCLR}}$  becomes input-only and pin functions such as internal weak pull-ups are under software control.

#### Related Links

[14.3 I/O Priorities](#)

### 8.5 Windowed Watchdog Timer (WWDT) Reset

The Windowed Watchdog Timer generates a Reset if the firmware does not issue a `CLRWDT` instruction within the time-out period or window set. The  $\overline{\text{TO}}$  and  $\overline{\text{PD}}$  bits in the STATUS register and the `RWDT` bit are changed to indicate a WDT Reset. The `WDTWV` bit indicates if the WDT Reset has occurred due to a timeout or a window violation.

#### Related Links

[7.8.4 STATUS](#)

[12. \(WWDT\) Windowed Watchdog Timer](#)

### 8.6 RESET Instruction

A `RESET` instruction will cause a device Reset. The  $\overline{\text{RI}}$  bit will be set to '0'. See “Reset Condition for Special Registers” table for default conditions after a `RESET` instruction has occurred.

### 8.7 Stack Overflow/Underflow Reset

The device can reset when the Stack Overflows or Underflows. The `STKOVF` or `STKUNF` bits register indicate the Reset condition. These Resets are enabled by setting the `STVREN` bit in Configuration Words.

#### Related Links

[4.7.2 CONFIG2](#)

[7.5.2 Overflow/Underflow Reset](#)

### 8.8 Programming Mode Exit

Upon exit of Programming mode, the device will behave as if a POR had just occurred.

---

---

## 8.9 Power-up Timer (PWRT)

The Power-up Timer optionally delays device execution after a BOR or POR event. This timer is typically used to allow  $V_{DD}$  to stabilize before allowing the device to start running.

The Power-up Timer is controlled by the PWRTS bit field of the Configuration Words.

The Power-up Timer provides a nominal 64 ms timeout on POR or Brown-out Reset.

The device is held in Reset as long as PWRT is active. The PWRT delay allows additional time for the  $V_{DD}$  to rise to an acceptable level. The Power-up Timer is enabled by setting a non-zero value in the PWRTS bit field, in Configuration Words.

The Power-up Timer starts after the release of the POR and BOR.

For additional information, refer to Application Note AN607, “*Power-up Trouble Shooting*” (DS00000607).

## 8.10 Start-up Sequence

Upon the release of a POR or BOR, the following must occur before the device will begin executing:

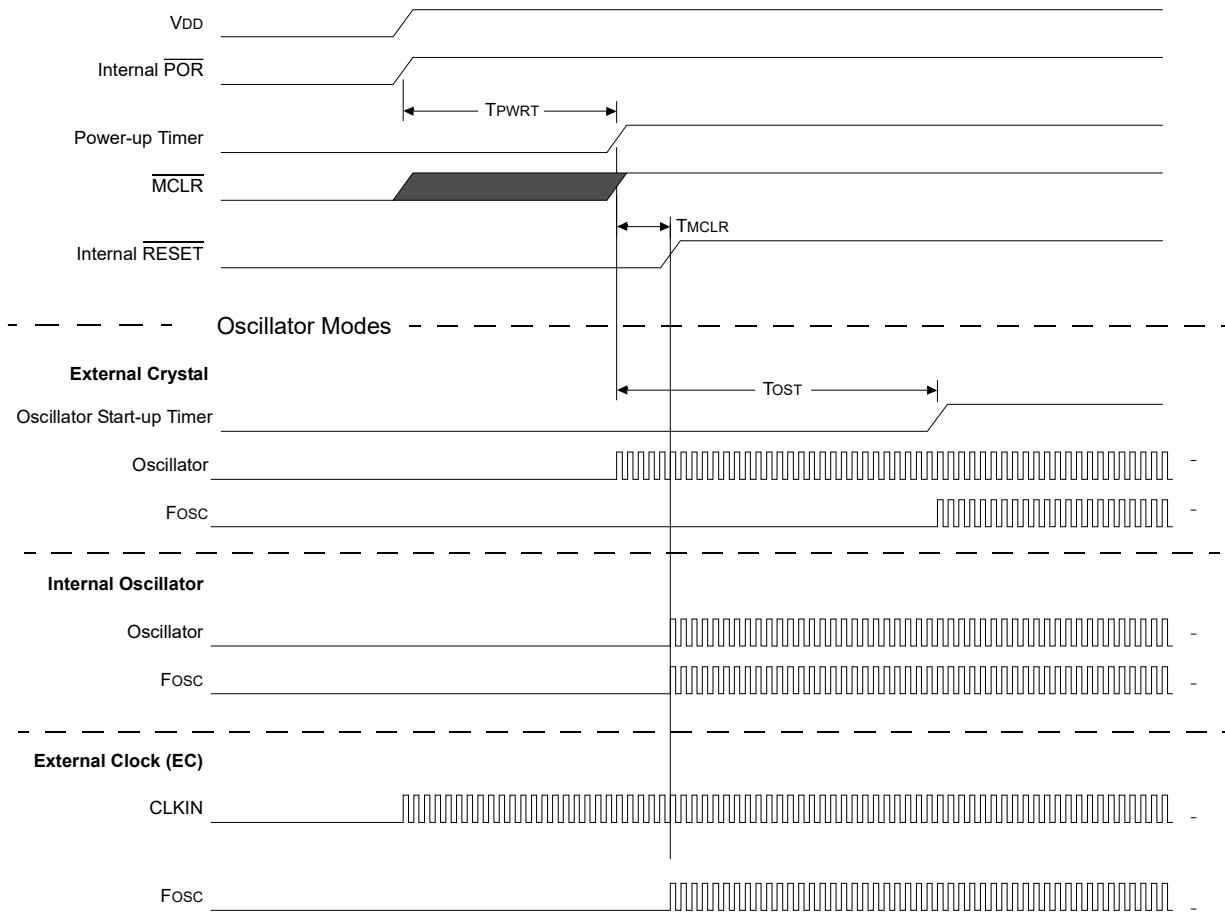
1. Power-up Timer runs to completion (if enabled).
2. Oscillator start-up timer runs to completion (if required for selected oscillator source).
3.  $\overline{MCLR}$  must be released (if enabled).

The total timeout will vary based on oscillator configuration and Power-up Timer configuration.

The Power-up Timer and oscillator start-up timer run independently of  $\overline{MCLR}$  Reset. If  $\overline{MCLR}$  is kept low long enough, the Power-up Timer and oscillator Start-up Timer will expire. Upon bringing  $\overline{MCLR}$  high, the device will begin execution after ten  $F_{OSC}$  cycles (see figure below). This is useful for testing purposes or to synchronize more than one device operating in parallel.

Figure 8-4. Reset Start-up Sequence

Rev. 30-00000A  
4/12/2017



**Related Links**

[9. Oscillator Module \(with Fail-Safe Clock Monitor\)](#)

**8.11 Memory Execution Violation**

A Memory Execution Violation Reset occurs if executing an instruction being fetched from outside the valid execution area. The different valid execution areas are defined as follows:

- Flash Memory: The “Device Sizes and Addresses” table shows the addresses available on the PIC16(L)F18455/56 devices based on user Flash size. Execution outside this region generates a memory execution violation.
- Storage Area Flash (SAF): If Storage Area Flash (SAF) is enabled, the SAF area is not a valid execution area.

Prefetched instructions that are not executed do not cause memory execution violations. For example, a GOTO instruction in the last memory location will prefetch from an invalid location; this is not an error. If an instruction from an invalid location tries to execute, the memory violation is generated immediately, and any concurrent interrupt requests are ignored. When a memory execution violation is generated, the device is reset and flag MEMV is cleared in PCON1 to signal the cause. The flag needs to be set in code after a memory execution violation.

**Related Links**

- 7.1 Program Memory Organization
- 7.2.3 Storage Area Flash
- 7.2.5 Memory Violation

## 8.12 Determining the Cause of a Reset

Upon any Reset, multiple bits in the STATUS and PCON0 registers are updated to indicate the cause of the Reset. The following tables show the Reset conditions of these registers.

**Table 8-3. Reset Status Bits and Their Significance**

STOVF	STKUNF	RWDT	RMCLR	RI	POR	BOR	TO	PD	MEMV	Condition
0	0	1	1	1	0	x	1	1	1	Power-on Reset
0	0	1	1	1	0	x	0	x	u	Illegal, $\overline{TO}$ is set on $\overline{POR}$
0	0	1	1	1	0	x	x	0	u	Illegal, $\overline{PD}$ is set on $\overline{POR}$
0	0	u	1	1	u	0	1	1	u	Brown-out Reset
u	u	0	u	u	u	u	0	u	u	WWDT Reset
u	u	u	u	u	u	u	0	0	u	WWDT Wake-up from Sleep
u	u	u	u	u	u	u	1	0	u	Interrupt Wake-up from Sleep
u	u	u	0	u	u	u	u	u	1	$\overline{MCLR}$ Reset during normal operation
u	u	u	0	u	u	u	1	0	u	$\overline{MCLR}$ Reset during Sleep
u	u	u	u	0	u	u	u	u	u	RESET Instruction Executed
1	u	u	u	u	u	u	u	u	u	Stack Overflow Reset (STVREN = 1)
u	1	u	u	u	u	u	u	u	u	Stack Underflow Reset (STVREN = 1)
u	u	u	u	u	u	u	u	u	0	Memory violation Reset

**Table 8-4. Reset Condition for Special Registers**

Condition	Program Counter	STATUS Register	PCON0 Register	PCON1 Register
Power-on Reset	0	---1 1000	0011 110x	---- --1-
Brown-out Reset	0	---1 1000	0011 11u0	---- --u-
$\overline{MCLR}$ Reset during normal operation	0	-uuu uuuu	uuuu 0uuu	---- --1-
$\overline{MCLR}$ Reset during Sleep	0	---1 0uuu	uuuu 0uuu	---- --u-
WWDT Time-out Reset	0	---0 uuuu	uuu0 uuuu	---- --u-
WWDT Wake-up from Sleep	PC + 1	---0 0uuu	uuuu uuuu	---- --u-

Condition	Program Counter	STATUS Register	PCON0 Register	PCON1 Register
WWDT Window Violation Reset	0	---u uuuu	uu0u uuuu	---- --u-
Interrupt Wake-up from Sleep	PC + 1 <sup>(1)</sup>	---1 0uuu	uuuu uuuu	---- --u-
RESET Instruction Executed	0	---u uuuu	uuuu u0uu	---- --u-
Stack Overflow Reset (STVREN = 1)	0	---u uuuu	1uuu uuuu	---- --u-
Stack Underflow Reset (STVREN = 1)	0	---u uuuu	u1uu uuuu	---- --u-
Memory Violation Reset ( $\overline{\text{MEMV}} = 0$ )	0	-uuu uuuu	uuuu uuuu	---- --0-

**Legend:** u = unchanged, x = unknown, — = unimplemented bit, reads as '0'.

**Note:**

- When the wake-up is due to an interrupt and Global Enable bit (GIE) is set, the return address is pushed on the stack and PC is loaded with the interrupt vector (0004h) after execution of PC + 1.

**Related Links**

[7.8.4 STATUS](#)

## 8.13 Power Control (PCONx) Register

The Power Control (PCONx) registers contain flag bits to differentiate between a:

- Brown-out Reset ( $\overline{\text{BOR}}$ )
- Power-on Reset ( $\overline{\text{POR}}$ )
- Reset Instruction Reset ( $\overline{\text{RI}}$ )
- $\overline{\text{MCLR}}$  Reset ( $\overline{\text{RMCLR}}$ )
- Watchdog Timer Reset ( $\overline{\text{RWDT}}$ )
- Watchdog Window Violation ( $\overline{\text{WDTWV}}$ )
- Stack Underflow Reset (STKUNF)
- Stack Overflow Reset (STKOVF)
- Memory Violation Reset ( $\overline{\text{MEMV}}$ )

Hardware will change the corresponding register bit during the Reset process; if the Reset was not caused by the condition, the bit remains unchanged.

Software should reset the bit to the inactive state after restart (hardware will not reset the bit).

Software may also set any PCONx bit to the active state, so that user code may be tested, but no Reset action will be generated.

**Related Links**

[8.12 Determining the Cause of a Reset](#)

[8.15.2 PCON0](#)

[8.15.3 PCON1](#)

### 8.14 Register Summary - BOR Control and Power Control

Address	Name	Bit Pos.								
0x0811	BORCON	7:0	SBOREN							BORRDY
0x0812	Reserved									
0x0813	PCON0	7:0	STKOVF	STKUNF	WDTWV	RWDT	RMCLR	RI	POR	BOR
0x0814	PCON1	7:0							MEMV	

### 8.15 Register Definitions: Power Control



8.15.1 BORCON

**Name:** BORCON

**Address:** 0x811

Brown-out Reset Control Register

Bit	7	6	5	4	3	2	1	0
	SBOREN							BORRDY
Access	R/W							R
Reset	1							q

**Bit 7 – SBOREN** Software Brown-out Reset Enable bit

Reset States: POR/BOR = 1

All Other Resets = u

Value	Condition	Description
–	If BOREN≠ 01	SBOREN is read/write, but has no effect on the BOR.
1	If BOREN= 01	BOR Enabled
0	If BOREN= 01	BOR Disabled

**Bit 0 – BORRDY** Brown-out Reset Circuit Ready Status bit

Reset States: POR/BOR = q

All Other Resets = u

Value	Description
1	The Brown-out Reset Circuit is active and armed
0	The Brown-out Reset Circuit is disabled or is warming up

**Related Links**

[4.7.2 CONFIG2](#)

8.15.2 PCON0

Name: PCON0

Address: 0x813

Power Control Register 0

Bit	7	6	5	4	3	2	1	0
	STKOVF	STKUNF	WDTWV	RWDT	RMCLR	RI	POR	BOR
Access	R/W/HS	R/W/HS	R/W/HC	R/W/HC	R/W/HC	R/W/HC	R/W/HC	R/W/HC
Reset	0	0	1	1	1	1	0	q

**Bit 7 – STKOVF** Stack Overflow Flag bit

Reset States: POR/BOR = 0

All Other Resets = q

Value	Description
1	A Stack Overflow occurred (more CALLS than fit on the stack)
0	A Stack Overflow has not occurred or set to '0' by firmware

**Bit 6 – STKUNF** Stack Underflow Flag bit

Reset States: POR/BOR = 0

All Other Resets = q

Value	Description
1	A Stack Underflow occurred (more RETURNS than CALLS)
0	A Stack Underflow has not occurred or set to '0' by firmware

**Bit 5 – WDTWV** Watchdog Window Violation Flag bit

Reset States: POR/BOR = 1

All Other Resets = q

Value	Description
1	A WDT window violation has not occurred or set to '1' by firmware
0	A CLRWDT instruction was issued when the WDT Reset window was closed (set to '0' in hardware when a WDT window violation Reset occurs)

**Bit 4 – RWDT** WDT Reset Flag bit

Reset States: POR/BOR = 1

All Other Resets = q

Value	Description
1	A WDT overflow/time-out Reset has not occurred or set to '1' by firmware
0	A WDT overflow/time-out Reset has occurred (set to '0' in hardware when a WDT Reset occurs)

**Bit 3 – RMCLR** MCLR Reset Flag bit

Reset States: POR/BOR = 1

All Other Resets = q

Value	Description
1	A $\overline{\text{MCLR}}$ Reset has not occurred or set to '1' by firmware
0	A $\overline{\text{MCLR}}$ Reset has occurred (set to '0' in hardware when a $\overline{\text{MCLR}}$ Reset occurs)

**Bit 2 –  $\overline{\text{RI}}$**  RESET Instruction Flag bit

Reset States: POR/BOR = 1

All Other Resets = q

Value	Description
1	A RESET instruction has not been executed or set to '1' by firmware
0	A RESET instruction has been executed (set to '0' in hardware upon executing a RESET instruction)

**Bit 1 –  $\overline{\text{POR}}$**  Power-on Reset Status bit

Reset States: POR/BOR = 0

All Other Resets = u

Value	Description
1	No Power-on Reset occurred or set to '1' by firmware
0	A Power-on Reset occurred (set to '0' in hardware when a Power-on Reset occurs)

**Bit 0 –  $\overline{\text{BOR}}$**  Brown-out Reset Status bit

Reset States: POR/BOR = q

All Other Resets = u

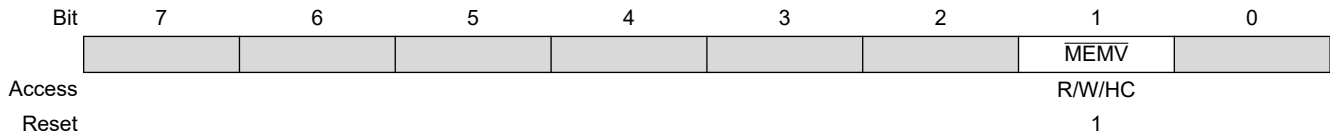
Value	Description
1	No Brown-out Reset occurred or set to '1' by firmware
0	A Brown-out Reset occurred (set to '0' in hardware when a Brown-out Reset occurs)

8.15.3 PCON1

**Name:** PCON1

**Address:** 0x814

Power Control Register 1



**Bit 1 – MEMV** Memory Violation Flag bit

Reset States: POR/BOR = 1

All Other Resets = u

Value	Description
1	No Memory Violation Reset occurred or set to '1' by firmware.
0	A Memory Violation Reset occurred (set to '0' in hardware when a Memory Violation occurs)

## 9. Oscillator Module (with Fail-Safe Clock Monitor)

### 9.1 Overview

The oscillator module has multiple clock sources and selection features that allow it to be used in a wide range of applications while maximizing performance and minimizing power consumption. The following figure illustrates a block diagram of the oscillator module.

Clock sources can be supplied from external oscillators, quartz-crystal resonators and ceramic resonators. In addition, the system clock source can be supplied from one of two internal oscillators and PLL circuits, with a choice of speeds selectable via software. Additional clock features include:

- Selectable system clock source between external or internal sources via software.
- Fail-Safe Clock Monitor (FSCM) designed to detect a failure of the external clock source (LP, XT, HS, ECH, ECM, ECL) and switch automatically to the internal oscillator.
- Oscillator Start-up Timer (OST) ensures stability of crystal oscillator sources.

The RSTOSC bits of Configuration Word 1 determine the type of oscillator that will be used when the device runs after Reset, including when it is first powered up.

The internal clock modes, LFINTOSC, HFINTOSC (set at 1 MHz), or HFINTOSC (set at 32 MHz) can be set through the RSTOSC bits.

If an external clock source is selected, the FEXTOSC bits of Configuration Word 1 must be used in conjunction with the RSTOSC bits to select the External Clock mode.

The external oscillator module can be configured in one of the following clock modes, by setting the FEXTOSC bits of Configuration Word 1:

1. ECL – External Clock Low-Power mode  
( $\leq 500$  kHz)
2. ECM – External Clock Medium-Power mode  
( $\leq 8$  MHz)
3. ECH – External Clock High-Power mode  
( $\leq 32$  MHz)
4. LP – 32 kHz Low-Power Crystal mode.
5. XT – Medium Gain Crystal or Ceramic Resonator Oscillator mode (between 100 kHz and 4 MHz)
6. HS – High Gain Crystal or Ceramic Resonator mode (above 4 MHz)

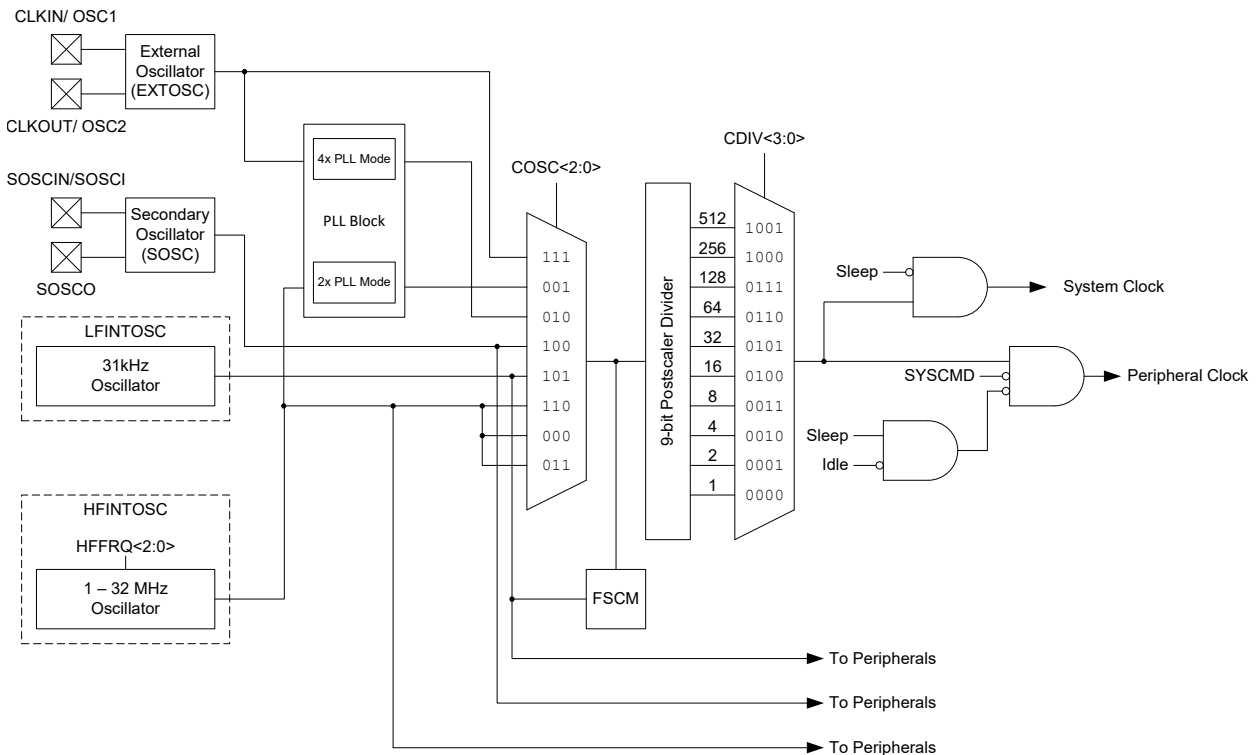
The ECH, ECM, and ECL Clock modes rely on an external logic level signal as the device clock source. The LP, XT, and HS Clock modes require an external crystal or resonator to be connected to the device. Each mode is optimized for a different frequency range. The internal oscillator block produces low and high-frequency clock sources, designated LFINTOSC and HFINTOSC. Multiple device clock frequencies may be derived from these clock sources.

# PIC16(L)F18455/56

## Oscillator Module (with Fail-Safe Clock Monitor)

Figure 9-1. Simplified PIC<sup>®</sup> MCU Clock Source Block Diagram

Rev: 10-000098M  
5/17/2017



### Related Links

[4.7.1 CONFIG1](#)

## 9.2 Clock Source Types

Clock sources can be classified as external or internal.

External clock sources rely on external circuitry for the clock source to function. Examples are: oscillator modules (ECH, ECM, ECL mode), quartz crystal resonators or ceramic resonators (LP, XT and HS modes).

There is also a secondary oscillator block which is optimized for a 32.768 kHz external clock source, which can be used as an alternate clock source.

There are two internal oscillator blocks:

- HFINTOSC
- LFINTOSC

The HFINTOSC can produce clock frequencies from 1-32 MHz, and is responsible for generating the two MFINTOSC frequencies (500 kHz and 32 kHz) that can be used by some peripherals. The LFINTOSC generates a 31 kHz clock frequency.

There is a 4x PLL that can be used by the external oscillator. Additionally, there is a PLL that can be used by the HFINTOSC at certain frequencies.

### Related Links

[9.2.1.4 4x PLL](#)

[9.2.2.3 2x PLL](#)

**9.2.1 External Clock Sources**

An external clock source can be used as the device system clock by performing one of the following actions:

- Program the RSTOSC bits in the Configuration Words to select an external clock source that will be used as the default system clock upon a device Reset.
- Write the [NOSC](#) and [NDIV](#) bits to switch the system clock source.

**Related Links**

[9.3 Clock Switching](#)

**9.2.1.1 EC Mode**

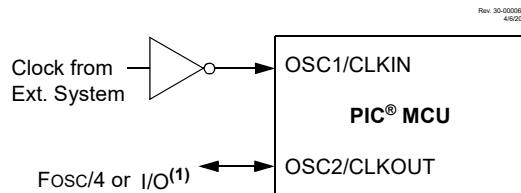
The External Clock (EC) mode allows an externally generated logic level signal to be the system clock source. When operating in this mode, an external clock source is connected to the CLKIN/OSC1 input. OSC2/CLKOUT is available for general purpose I/O or CLKOUT. The following figure shows the pin connections for EC mode.

EC mode has three power modes to select from through Configuration Words:

- ECH – High power,  $\leq 32$  MHz
- ECM – Medium power,  $\leq 8$  MHz
- ECL – Low power,  $\leq 0.1$  MHz

The Oscillator Start-up Timer (OST) is disabled when EC mode is selected. Therefore, there is no delay in operation after a Power-on Reset (POR) or wake-up from Sleep. Because the PIC<sup>®</sup> MCU design is fully static, stopping the external clock input will have the effect of halting the device while leaving all data intact. Upon restarting the external clock, the device will resume operation as if no time had elapsed.

**Figure 9-2. External Clock (EC) Mode Operation**



**Note:**

1. Output depends upon  $\overline{\text{CLKOUTEN}}$  bit of the Configuration Words (CONFIG1H).

**9.2.1.2 LP, XT, HS Modes**

The LP, XT and HS modes support the use of quartz crystal resonators or ceramic resonators connected to OSC1 and OSC2 ([Figure 9-3](#)). The three modes select a low, medium or high gain setting of the internal inverter-amplifier to support various resonator types and speed.

**LP** Oscillator mode selects the lowest gain setting of the internal inverter-amplifier. LP mode current consumption is the least of the three modes. This mode is designed to drive only 32.768 kHz tuning-fork type crystals (watch crystals). but can operate up to 100 kHz.

**XT** Oscillator mode selects the intermediate gain setting of the internal inverter-amplifier. XT mode current consumption is the medium of the three modes. This mode is best suited to drive crystals and resonators with a frequency range up to 4 MHz.

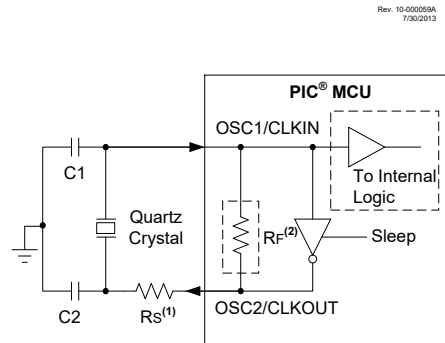
# PIC16(L)F18455/56

## Oscillator Module (with Fail-Safe Clock Monitor)

**HS** Oscillator mode selects the highest gain setting of the internal inverter-amplifier. HS mode current consumption is the highest of the three modes. This mode is best suited for resonators that require operating frequencies up to 20 MHz.

Figure 9-3 and Figure 9-4 show typical circuits for quartz crystal and ceramic resonators, respectively.

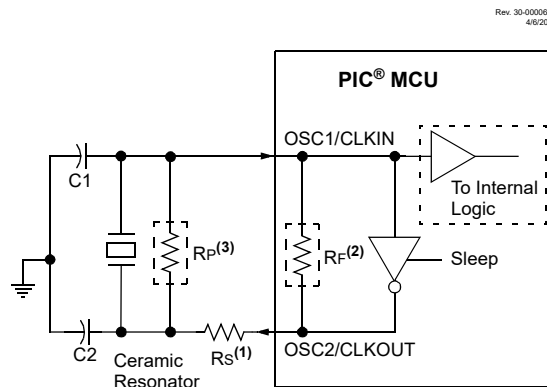
**Figure 9-3. Quartz Crystal Operation (LP, XT or HS Mode)**



**Note:**

1. A series resistor ( $R_S$ ) may be required for quartz crystals with low drive level.
2. The value of  $R_F$  varies with the Oscillator mode selected (typically between 2 M $\Omega$  to 10 M $\Omega$ ).

**Figure 9-4. Ceramic Resonator Operation (XT or HS Mode)**



**Note:**

1. A series resistor ( $R_S$ ) may be required for ceramic resonators with low drive level.
2. The value of  $R_F$  varies with the Oscillator mode selected (typically between 2 M $\Omega$  to 10 M $\Omega$ ).
3. An additional parallel feedback resistor ( $R_P$ ) may be required for proper ceramic resonator operation.

### 9.2.1.3 Oscillator Start-up Timer (OST)

If the oscillator module is configured for LP, XT or HS modes, the Oscillator Start-up Timer (OST) counts 1024 oscillations from OSC1. This occurs following a Power-on Reset (POR), or a wake-up from Sleep. The OST ensures that the oscillator circuit, using a quartz crystal resonator or ceramic resonator, has started and is providing a stable system clock to the oscillator module.



#### 9.2.1.4 4x PLL

The oscillator module contains a 4x PLL that can be used with the external clock sources to provide a system clock source. The input frequency for the PLL must fall within specifications.

The PLL can be enabled for use by one of two methods:

1. Program the RSTOSC bits in the Configuration Word 1 to '010' (enable EXTOSC with 4x PLL).
2. Write the NOSC bits to '010' (enable EXTOSC with 4x PLL).

#### Related Links

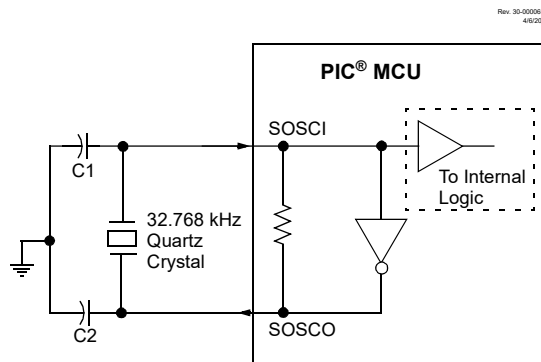
[9.6.1 OSCCON1](#)

[42.4.3 PLL Specifications](#)

#### 9.2.1.5 Secondary Oscillator

The secondary oscillator is a separate oscillator block that can be used as an alternate system clock source. The secondary oscillator is optimized for 32.768 kHz, and can be used with an external crystal oscillator connected to the SOSC1 and SOSCO device pins, or an external clock source connected to the SOSCIN pin. The secondary oscillator can be selected during run-time using clock switching.

**Figure 9-5. Quartz Crystal Operation (Secondary Oscillator)**



#### Note:

1. Quartz crystal characteristics vary according to type, package and manufacturer. The user should consult the manufacturer data sheets for specifications and recommended application.
2. Always verify oscillator performance over the  $V_{DD}$  and temperature range that is expected for the application.
3. For oscillator design assistance, reference the following Microchip Application Notes:
  - AN826, “Crystal Oscillator Basics and Crystal Selection for PIC<sup>®</sup> and PIC<sup>®</sup> Devices” (DS00826)
  - AN849, “Basic PIC<sup>®</sup> Oscillator Design” (DS00849)
  - AN943, “Practical PIC<sup>®</sup> Oscillator Analysis and Design” (DS00943)
  - AN949, “Making Your Oscillator Work” (DS00949)
  - TB097, “Interfacing a Micro Crystal MS1V-T1K 32.768 kHz Tuning Fork Crystal to a PIC16F690/SS” (DS91097)
  - AN1288, “Design Practices for Low-Power External Oscillators” (DS01288)

#### Related Links

[9.3 Clock Switching](#)

## 9.2.2 Internal Clock Sources

The device may be configured to use the internal oscillator block as the system clock by performing one of the following actions:

- Program the RSTOSC bits in Configuration Words to select the INTOSC clock source, which will be used as the default system clock upon a device Reset.
- Write the [NOSC](#) bits to switch the system clock source to the internal oscillator during run-time.

In INTOSC mode, OSC1/CLKIN is available for general purpose I/O. OSC2/CLKOUT is available for general purpose I/O or CLKOUT.

The function of the OSC2/CLKOUT pin is determined by the  $\overline{\text{CLKOUTEN}}$  bit in Configuration Words.

The internal oscillator block has two independent oscillators that can produce two internal system clock sources.

1. The **HFINTOSC** (High-Frequency Internal Oscillator) is factory-calibrated and operates up to 32 MHz. The frequency of HFINTOSC can be selected through the OSCFRQ Frequency Selection register, and fine-tuning can be done via the OSCTUNE register.
2. The **LFINTOSC** (Low-Frequency Internal Oscillator) is factory-calibrated and operates at 31 kHz.

### Related Links

[9.3 Clock Switching](#)

### 9.2.2.1 HFINTOSC

The High-Frequency Internal Oscillator (HFINTOSC) is a precision digitally-controlled internal clock source that produces a stable clock up to 32 MHz. The HFINTOSC can be enabled through one of the following methods:

- Programming the RSTOSC bits in Configuration Word 1 to '110' ( $F_{\text{OSC}} = 1 \text{ MHz}$ ) or '000' ( $F_{\text{OSC}} = 32 \text{ MHz}$ ) to set the oscillator upon device Power-up or Reset.
- Write to the [NOSC](#) bits during run-time.

The HFINTOSC frequency can be selected by setting the [HFFRQ](#) bits.

The [NDIV](#) bits allow for division of the HFINTOSC output from a range between 1:1 and 1:512.

### Related Links

[9.3 Clock Switching](#)

[9.6.1 OSCCON1](#)

[9.6.7 OSCFRQ](#)

### 9.2.2.2 MFINTOSC

The module provides two (500 kHz and 31.25 kHz) constant clock outputs. These clocks are digital divisors of the HFINTOSC clock. Dynamic divider logic is used to provide constant MFINTOSC clock rates for all settings of HFINTOSC.

The MFINTOSC cannot be used to drive the system but it is used to clock certain modules such as the Timers and WWDT.

### 9.2.2.3 2x PLL

The oscillator module contains a PLL that can be used with the HFINTOSC clock source to provide a system clock source. The input frequency to the PLL is limited to 8, 12, or 16 MHz, which will yield a system clock source of 16, 24, or 32 MHz, respectively.

The PLL may be enabled for use by one of two methods:

1. Program the RSTOSC bits in the Configuration Word 1 to '001' to enable the HFINTOSC (32 MHz). This setting configures the HFFRQ bits to '101' (16 MHz) and activates the 2x PLL.
2. Write '001' the NOSC bits to enable the 2x PLL, and write the correct value into the HFFRQ to select the desired system clock frequency.

**Related Links**

[9.6.1 OSCCON1](#)

[9.6.7 OSCFRQ](#)

**9.2.2.4 Internal Oscillator Frequency Adjustment**

The internal oscillator is factory-calibrated. This internal oscillator can be adjusted in software by writing to the OSCTUNE register.

The default value of the OSCTUNE register is 00h. The value is a 6-bit two's complement number. A value of 1Fh will provide an adjustment to the maximum frequency. A value of 20h will provide an adjustment to the minimum frequency.

When the OSCTUNE register is modified, the oscillator frequency will begin shifting to the new frequency. Code execution continues during this shift. There is no indication that the shift has occurred.

OSCTUNE **does not affect** the LFINTOSC frequency. Operation of features that depend on the LFINTOSC clock source frequency, such as the Power-up Timer (PWRT), WWDT, Fail-Safe Clock Monitor (FSCM) and peripherals, are not affected by the change in frequency.

**Related Links**

[9.6.6 OSCTUNE](#)

**9.2.2.5 LFINTOSC**

The Low-Frequency Internal Oscillator (LFINTOSC) is a factory-calibrated 31 kHz internal clock source.

The LFINTOSC is the frequency for the Power-up Timer (PWRT), Windowed Watchdog Timer (WWDT) and Fail-Safe Clock Monitor (FSCM).

The LFINTOSC is enabled through one of the following methods:

- Programming the RSTOSC bits of Configuration Word 1 to enable LFINTOSC.
- Write to the NOSC bits during run-time.

**Related Links**

[9.3 Clock Switching](#)

[4.7.1 CONFIG1](#)

[9.6.1 OSCCON1](#)

**9.2.2.6 ADCRC (also referred to as FRC)**

The ADCRC is an oscillator dedicated to the ADC<sup>2</sup> module. The ADCRC oscillator can be manually enabled using the ADOEN bit. The ADCRC runs at a fixed frequency of 600 kHz. ADCRC is automatically enabled if it is selected as the clock source for the ADC<sup>2</sup> module.

**9.2.2.7 Oscillator Status and Manual Enable**

The 'ready' status of each oscillator is displayed in the OSCSTAT register. The oscillators can also be manually enabled through the OSCEN register. Manual enabling makes it possible to verify the operation of the EXTOSC or SOSC crystal oscillators. This can be achieved by enabling the selected oscillator, then watching the corresponding 'ready' state of the oscillator in the OSCSTAT register.

#### Related Links

[9.6.4 OSCSTAT](#)

[9.6.5 OSCEN](#)

#### 9.2.2.8 HFOR and MFOR Bits

The [HFOR](#) and [MFOR](#) bits indicate that the HFINTOSC and MFINTOSC is ready. These clocks are always valid for use at all times, but only accurate after they are ready.

When a new value is loaded into the OSCFRQ register, the HFOR and MFOR bits will clear, and set again when the oscillator is ready. During pending OSCFRQ changes the MFINTOSC clock will stall at a high or a low state, until the HFINTOSC resumes operation.

### 9.3 Clock Switching

The system clock source can be switched between external and internal clock sources via software using the New Oscillator Source ([NOSC](#)) and New Divider selection request ([NDIV](#)) bits. The following clock sources can be selected:

- External Oscillator (EXTOSC)
- High-Frequency Internal Oscillator (HFINTOSC)
- Low-Frequency Internal Oscillator (LFINTOSC)
- Secondary Oscillator (SOSC)
- EXTOSC with 4x PLL
- HFINTOSC with 2x PLL

#### 9.3.1 New Oscillator Source (NOSC) and New Divider Selection Request (NDIV) Bits

The New Oscillator Source (NOSC) and New Divider Selection Request (NDIV) bits select the system clock source and frequency that are used for the CPU and peripherals.

When new values of NOSC and NDIV are written to OSCCON1, the current oscillator selection will continue to operate while waiting for the new clock source to indicate that it is stable and ready. In some cases, the newly requested source may already be in use, and is ready immediately. In the case of a divider-only change, the new and old sources are the same, so the old source will be ready immediately. The device may enter Sleep while waiting for the switch.

When the new oscillator is ready, the New Oscillator Ready (NOSCR) bit is set and also the Clock Switch Interrupt Flag (CSWIF) bit of PIR1 sets. If Clock Switch Interrupts are enabled (CSWIE = 1), an interrupt will be generated at that time. The Oscillator Ready (ORDY) bit of OSCCON3 can also be polled to determine when the oscillator is ready in lieu of an interrupt.

If the Clock Switch Hold (CSWHOLD) bit is clear, the oscillator switch will occur when the New Oscillator is READY bit (NOSCR) is set, and the interrupt (if enabled) will be serviced at the new oscillator setting.

If CSWHOLD is set, the oscillator switch is suspended, while execution continues using the current (old) clock source. When the NOSCR bit is set, software should:

- Set CSWHOLD = 0 so the switch can complete, or
- Copy COSC into NOSC to abandon the switch.

If DOZE is in effect, the switch occurs on the next clock cycle, whether or not the CPU is operating during that cycle.

Changing the clock post-divider without changing the clock source (i.e., changing  $F_{OSC}$  from 1 MHz to 2 MHz) is handled in the same manner as a clock source change, as described previously. The clock

source will already be active, so the switch is relatively quick. CSWHOLD must be clear (CSWHOLD = 0) for the switch to complete.

The current COSC and CDIV are indicated in the OSCCON2 register up to the moment when the switch actually occurs, at which time OSCCON2 is updated and ORDY is set. NOSCR is cleared by hardware to indicate that the switch is complete.

### Related Links

[9.3.3 Clock Switch and Sleep](#)

[9.6.1 OSCCON1](#)

[9.6.2 OSCCON2](#)

[9.6.3 OSCCON3](#)

### 9.3.2 PLL Input Switch

Switching between the PLL and any non-PLL source is managed as described above. The input to the PLL is established when NOSC selects the PLL, and maintained by the COSC setting.

When NOSC and COSC select the PLL with different input sources, the system continues to run using the COSC setting, and the new source is enabled per NOSC. When the new oscillator is ready (and CSWHOLD = 0), system operation is suspended while the PLL input is switched and the PLL acquires lock. This provides a truly glitch-free clock switch operation.



**Important:** If the PLL fails to lock, the FSCM will trigger.

---

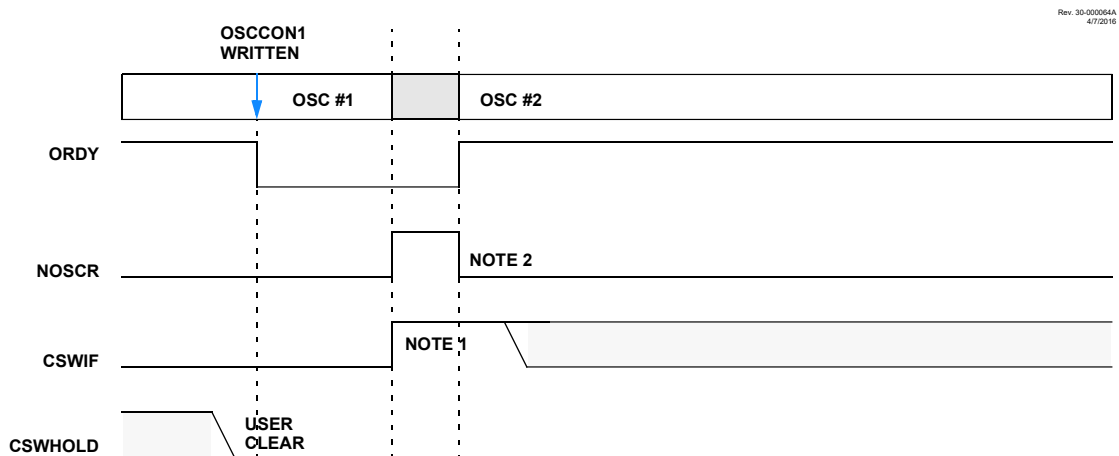
### 9.3.3 Clock Switch and Sleep

If OSCCON1 is written with a new value and the device is put to Sleep before the switch completes, the switch will not take place and the device will enter Sleep mode.

When the device wakes from Sleep and the CSWHOLD bit is clear, the device will wake with the 'new' clock active, and the Clock Switch Interrupt Flag bit (CSWIF) will be set.

When the device wakes from Sleep and the CSWHOLD bit is set, the device will wake with the 'old' clock active and the new clock will be requested again.

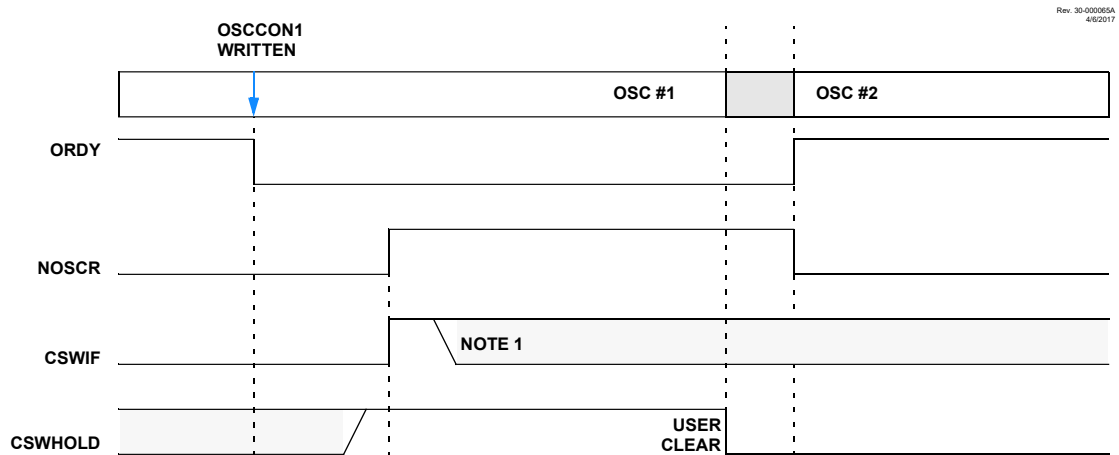
**Figure 9-6. Clock Switch (CSWHOLD = 0)**



**Note:**

1. CSWIF is asserted coincident with NOSCR; interrupt is serviced at OSC#2 speed.
2. The assertion of NOSCR is hidden from the user because it appears only for the duration of the switch.

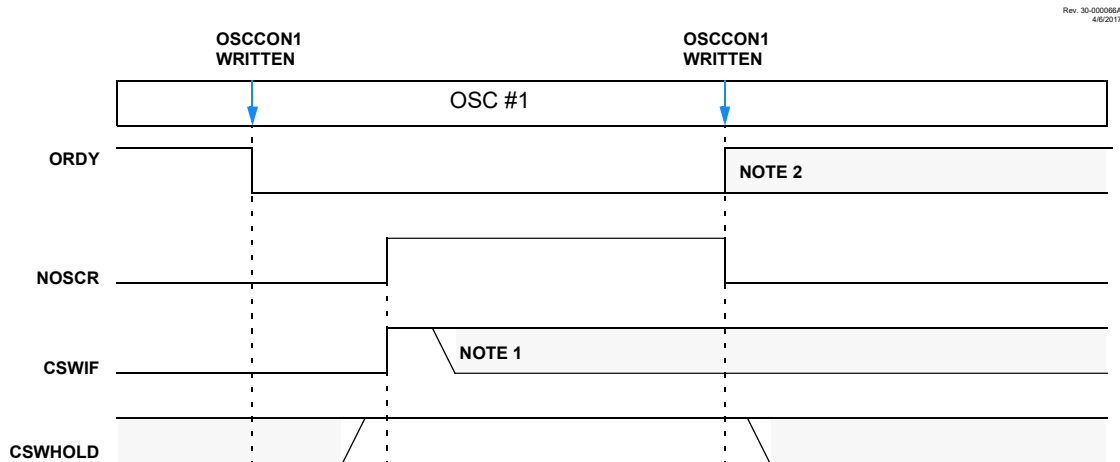
**Figure 9-7. Clock Switch (CSWHOLD = 1)**



**Note:**

1. CSWIF is asserted coincident with NOSCR, and may be cleared before or after clearing CSWHOLD = 0.

**Figure 9-8. Clock Switch Abandoned**



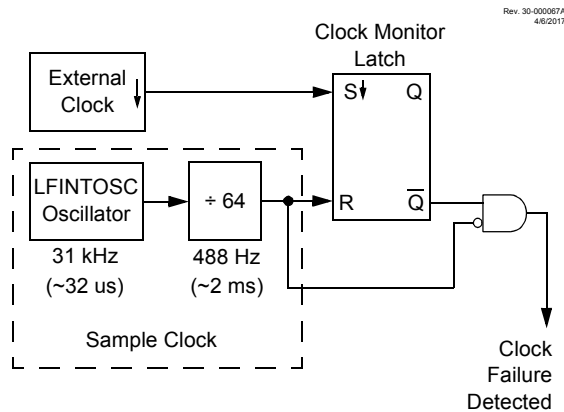
**Note:**

1. CSWIF may be cleared before or after rewriting OSCCON1; CSWIF is not automatically cleared.
2. ORDY = 0 if OSCCON1 does not match OSCCON2; a new switch will begin.

**9.4 Fail-Safe Clock Monitor**

The Fail-Safe Clock Monitor (FSCM) allows the device to continue operating should the external oscillator fail. The FSCM is enabled by setting the FCMEN bit in the Configuration Words. The FSCM is applicable to all external Oscillator modes (LP, XT, HS, ECL/M/H and Secondary Oscillator).

**Figure 9-9. FSCM Block Diagram**



**9.4.1 Fail-Safe Detection**

The FSCM module detects a failed oscillator by comparing the external oscillator to the FSCM sample clock. The sample clock is generated by dividing the LFINTOSC by 64. See Figure 9-9. Inside the fail detector block is a latch. The external clock sets the latch on each falling edge of the external clock. The sample clock clears the latch on each rising edge of the sample clock. A failure is detected when an entire half-cycle of the sample clock elapses before the external clock goes low.

**9.4.2 Fail-Safe Operation**

When the external clock fails, the FSCM overwrites the **COSC** bits to select HFINTOSC (3'b110). The frequency of HFINTOSC would be determined by the previous state of the HFFRQ bits and the **NDIV/CDIV** bits. The bit flag **OSCFIF** of the PIR1 register is set. Setting this flag will generate an interrupt if the **OSCFIE** bit of the PIE1 register is also set. The device firmware can then take steps to mitigate the problems that may arise from a failed clock. The system clock will continue to be sourced from the internal clock source until the device firmware successfully restarts the external oscillator and switches back to external operation, by writing to the **NOSC** and **NDIV** bits.

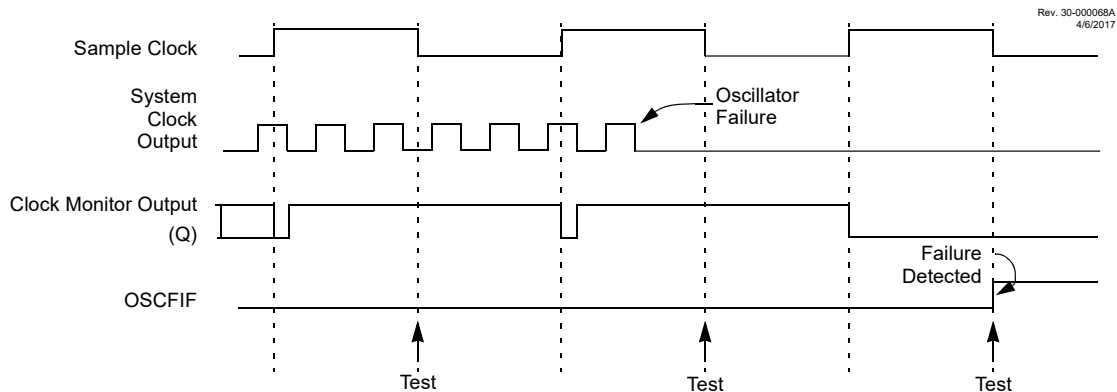
**9.4.3 Fail-Safe Condition Clearing**

The Fail-Safe condition is cleared after a Reset, executing a **SLEEP** instruction or changing the **NOSC** and **NDIV** bits. When switching to the external oscillator or PLL, the **OST** is restarted. While the **OST** is running, the device continues to operate from the **INTOSC** selected in **OSCCON1**. When the **OST** times out, the Fail-Safe condition is cleared after successfully switching to the external clock source. The **OSCFIF** bit should be cleared prior to switching to the external clock source. If the Fail-Safe condition still exists, the **OSCFIF** flag will again become set by hardware.

**9.4.4 Reset or Wake-up from Sleep**

The FSCM is designed to detect an oscillator failure after the Oscillator Start-up Timer (**OST**) has expired. The **OST** is used after waking up from Sleep and after any type of Reset. The **OST** is not used with the **EC** Clock modes so that the FSCM will be active as soon as the Reset or wake-up has completed.

**Figure 9-10. FSCM Timing Diagram**



**Note:** The system clock is normally at a much higher frequency than the sample clock. The relative frequencies in this example have been chosen for clarity.



## 9.5 Register Summary - OSC

Address	Name	Bit Pos.									
0x088D	<a href="#">OSCCON1</a>	7:0			NOSC[2:0]			NDIV[3:0]			
0x088E	<a href="#">OSCCON2</a>	7:0			COSC[2:0]			CDIV[3:0]			
0x088F	<a href="#">OSCCON3</a>	7:0	CSWHOLD	SOSCPWR		ORDY	NOSCR				
0x0890	<a href="#">OSCSTAT</a>	7:0	EXTOR	HFOR	MFOR	LFOR	SOR	ADOR		PLLR	
0x0891	<a href="#">OSCEN</a>	7:0	EXTOEN	HFOEN	MFOEN	LFOEN	SOSCEN	ADOEN			
0x0892	<a href="#">OSCTUNE</a>	7:0			HFTUN[5:0]						
0x0893	<a href="#">OSCFRQ</a>	7:0						HFFRQ[2:0]			

## 9.6 Register Definitions: Oscillator Control

# PIC16(L)F18455/56

## Oscillator Module (with Fail-Safe Clock Monitor)

### 9.6.1 OSCCON1

**Name:** OSCCON1  
**Address:** 0x88D

Oscillator Control Register1

Bit	7	6	5	4	3	2	1	0
	NOSC[2:0]				NDIV[3:0]			
Access		R/W	R/W	R/W	R/W	R/W	R/W	R/W
Reset		f	f	f	q	q	q	q

**Bits 6:4 – NOSC[2:0]** New Oscillator Source Request bits<sup>(1,2,3)</sup>  
 The setting requests a source oscillator and PLL combination per [Table 9-1](#).

**Table 9-1. NOSC Bit Settings**

NOSC<2:0>	Clock Source
111	EXTOSC <sup>(5)</sup>
110	HFINTOSC <sup>(6)</sup>
101	LFINTOSC
100	SOSC
011	Reserved
010	EXTOSC + 4x PLL <sup>(5)</sup>
001	HFINTOSC + 2x PLL <sup>(6)</sup>
000	Reserved

**Bits 3:0 – NDIV[3:0]** New Divider Selection Request bits<sup>(2,3,4)</sup>  
 The setting determines the new postscaler division ratio per [Table 9-2](#).

**Table 9-2. NDIV Bit Settings**

NDIV<3:0>	Clock Divider
1111-1010	Reserved
1001	512
1000	256
0111	128
0110	64
0101	32
0100	16
0011	8
0010	4

# PIC16(L)F18455/56

## Oscillator Module (with Fail-Safe Clock Monitor)

NDIV<3:0>	Clock Divider
0001	2
0000	1

**Note:**

1. The default value (f) is determined by the CONFIG1[RSTOSC] Configuration bits.
2. If NOSC is written with a reserved value, the operation is ignored and NOSC is not written.
3. When CONFIG1[CSWEN] = 0, this register is read-only and cannot be changed from the POR value.
4. When NOSC = 110 (HFINTOSC 1 MHz), the NDIV bits will default to '0010' upon Reset; for all other NOSC settings the NDIV bits will default to '0000' upon Reset.
5. EXTOSC configured by CONFIG1[FEXTOSC].
6. HFINTOSC frequency is set with the FRQ bits of the OSCFRQ register.

**Related Links**

[4.7.1 CONFIG1](#)

[42.4.3 PLL Specifications](#)

# PIC16(L)F18455/56

## Oscillator Module (with Fail-Safe Clock Monitor)

### 9.6.2 OSCCON2

**Name:** OSCCON2  
**Address:** 0x88E

Oscillator Control Register 2

Bit	7	6	5	4	3	2	1	0
	COSC[2:0]			CDIV[3:0]				
Access		RO	RO	RO	RO	RO	RO	RO
Reset		n	n	n	n	n	n	n

**Bits 6:4 – COSC[2:0]** Current Oscillator Source Select bits (read-only)<sup>(1,2)</sup>  
 Indicates the current source oscillator and PLL combination as shown in the following table.

**Table 9-3. COSC Bit Settings**

COSC/NOSC	Clock Source
111	EXTOSC <sup>(3)</sup>
110	HFINTOSC <sup>(4)</sup>
101	LFINTOSC
100	SOSC
011	Reserved
010	EXTOSC + 4x PLL <sup>(3)</sup>
001	HFINTOSC + 2x PLL <sup>(4)</sup>
000	Reserved

**Bits 3:0 – CDIV[3:0]** Current Divider Select bits (read-only)<sup>(1,2)</sup>  
 Indicates the current postscaler division ratio as shown in the following table.

**Table 9-4. CDIV Bit Settings**

CDIV/NDIV	Clock Divider
1111-1010	Reserved
1001	512
1000	256
0111	128
0110	64
0101	32
0100	16
0011	8
0010	4

# PIC16(L)F18455/56

## Oscillator Module (with Fail-Safe Clock Monitor)

CDIV/NDIV	Clock Divider
0001	2
0000	1

**Note:**

1. The POR value is the value present when user code execution begins.
2. The Reset value (n) is the same as the OSCCON1[NOSC/NDIV] bits.
3. EXTOSC configured by the CONFIG1[FEXTOSC] bits.
4. HFINTOSC frequency is configured with the FRQ bits of the OSCFRQ register

**Related Links**

[4.7.1 CONFIG1](#)

[42.4.3 PLL Specifications](#)

**9.6.3 OSCCON3**

**Name:** OSCCON3  
**Address:** 0x88F

Oscillator Control Register 3

Bit	7	6	5	4	3	2	1	0
	CSWHOLD	SOSCPWR		ORDY	NOSCR			
Access	R/W/HC	R/W		RO	RO			
Reset	0	0		0	0			

**Bit 7 – CSWHOLD** Clock Switch Hold bit

Value	Description
1	Clock switch will hold (with interrupt) when the oscillator selected by NOSC is ready
0	Clock switch may proceed when the oscillator selected by NOSC is ready; when NOSCR becomes '1', the switch will occur

**Bit 6 – SOSCPWR** Secondary Oscillator Power Mode Select bit

Value	Description
1	Secondary oscillator operating in High-Power mode
0	Secondary oscillator operating in Low-Power mode

**Bit 4 – ORDY** Oscillator Ready bit (read-only)

Value	Description
1	OSCCON1 = OSCCON2; the current system clock is the clock specified by NOSC
0	A clock switch is in progress

**Bit 3 – NOSCR** New Oscillator is Ready bit (read-only)<sup>(1)</sup>

Value	Description
1	A clock switch is in progress and the oscillator selected by NOSC indicates a ready condition
0	A clock switch is not in progress, or the NOSC-selected oscillator is not yet ready

**Note:**

1. If CSWHOLD = 0, the user may not see this bit set because the bit is set for less than one instruction cycle.

**9.6.4 OSCSTAT**

**Name:** OSCSTAT  
**Address:** 0x890

Oscillator Status Register 1

Bit	7	6	5	4	3	2	1	0
	EXTOR	HFOR	MFOR	LFOR	SOR	ADOR		PLLR
Access	RO	RO	RO	RO	RO	RO		RO
Reset	q	q	q	q	q	q		q

**Bit 7 – EXTOR** EXTOSC (external) Oscillator Ready bit

Value	Description
1	The oscillator is ready to be used
0	The oscillator is not enabled, or is not yet ready to be used

**Bit 6 – HFOR** HFINTOSC Oscillator Ready bit

Value	Description
1	The oscillator is ready to be used
0	The oscillator is not enabled, or is not yet ready to be used

**Bit 5 – MFOR** MFINTOSC Oscillator Ready bit

Value	Description
1	The oscillator is ready to be used
0	The oscillator is not enabled, or is not yet ready to be used

**Bit 4 – LFOR** LFINTOSC Oscillator Ready bit

Value	Description
1	The oscillator is ready to be used
0	The oscillator is not enabled, or is not yet ready to be used

**Bit 3 – SOR** Secondary (Timer1) Oscillator Ready bit

Value	Description
1	The oscillator is ready to be used
0	The oscillator is not enabled, or is not yet ready to be used

**Bit 2 – ADOR** ADC Oscillator Ready bit

Value	Description
1	The oscillator is ready to be used
0	The oscillator is not enabled, or is not yet ready to be used

**Bit 0 – PLLR** PLL Ready bit

# PIC16(L)F18455/56

## Oscillator Module (with Fail-Safe Clock Monitor)

Value	Description
1	The PLL is ready to be used
0	The PLL is not enabled, the required input source is not ready, or the PLL is not locked.



**9.6.5 OSCEN**

**Name:** OSCEN  
**Address:** 0x891

Oscillator Manual Enable Register

Bit	7	6	5	4	3	2	1	0
	EXTOEN	HFOEN	MFOEN	LFOEN	SOSCEN	ADOEN		
Access	R/W	R/W	R/W	R/W	R/W	R/W		
Reset	0	0	0	0	0	0		

**Bit 7 – EXTOEN** External Oscillator Manual Request Enable bit

Value	Description
1	EXTOSC is explicitly enabled, operating as specified by CONFIG1[FEXTOSC]
0	EXTOSC is only enabled if requested by a peripheral

**Bit 6 – HFOEN** HFINTOSC Oscillator Manual Request Enable bit

Value	Description
1	HFINTOSC is explicitly enabled, operating as specified by OSCFRQ
0	HFINTOSC is only enabled if requested by a peripheral

**Bit 5 – MFOEN** MFINTOSC (500 kHz/31.25 kHz) Oscillator Manual Request Enable bit (Derived from HFINTOSC)

Value	Description
1	MFINTOSC is explicitly enabled
0	MFINTOSC is only enabled if requested by a peripheral

**Bit 4 – LFOEN** LFINTOSC (31 kHz) Oscillator Manual Request Enable bit

Value	Description
1	LFINTOSC is explicitly enabled
0	LFINTOSC is only enabled if requested by a peripheral

**Bit 3 – SOSCEN** Secondary Oscillator Manual Request Enable bit

Value	Description
1	Secondary Oscillator is explicitly enabled, operating as specified by SOSCPWR
0	Secondary Oscillator is only enabled if requested by a peripheral

**Bit 2 – ADOEN** ADC Oscillator Manual Request Enable bit

Value	Description
1	ADC oscillator is explicitly enabled
0	ADC oscillator is only enabled if requested by a peripheral

**Related Links**

[4.7.1 CONFIG1](#)

# PIC16(L)F18455/56

## Oscillator Module (with Fail-Safe Clock Monitor)

### 9.6.6 OSCTUNE

**Name:** OSCTUNE  
**Address:** 0x892

HFINTOSC Tuning Register

Bit	7	6	5	4	3	2	1	0
			HFTUN[5:0]					
Access			R/W	R/W	R/W	R/W	R/W	R/W
Reset			0	0	0	0	0	0

**Bits 5:0 – HFTUN[5:0]** HFINTOSC Frequency Tuning bits

Value	Description
01 1111	Maximum frequency
00 0000	Center frequency. Oscillator module is running at the calibrated frequency (default value).
10 0000	Minimum frequency

# PIC16(L)F18455/56

## Oscillator Module (with Fail-Safe Clock Monitor)

### 9.6.7 OSCFRQ

**Name:** OSCFRQ  
**Address:** 0x893

HFINTOSC Frequency Selection Register

Bit	7	6	5	4	3	2	1	0
						HFFRQ[2:0]		
Access						R/W	R/W	R/W
Reset						q	q	q

**Bits 2:0 – HFFRQ[2:0]** HFINTOSC Frequency Selection bits

FRQ<2:0>	Nominal Frequency (MHz) (NOSC = 110)	2x PLL Frequency (MHz) (NOSC = 001)
111	Reserved	Reserved
110	32	
101	16	32
100	12	24
011	8	16
010	4	Reserved
001	2	
000	1	

**Note:**

- When RSTOSC = 110 (HFINTOSC 1 MHz), the FRQ bits will default to '010' upon Reset; when RSTOSC = 001 (HFINTOSC 32 MHz), the FRQ bits will default to '101' upon Reset.

## 10. Interrupts

The interrupt feature allows certain events to preempt normal program flow. Firmware is used to determine the source of the interrupt and act accordingly. Some interrupts can be configured to wake the MCU from Sleep mode.

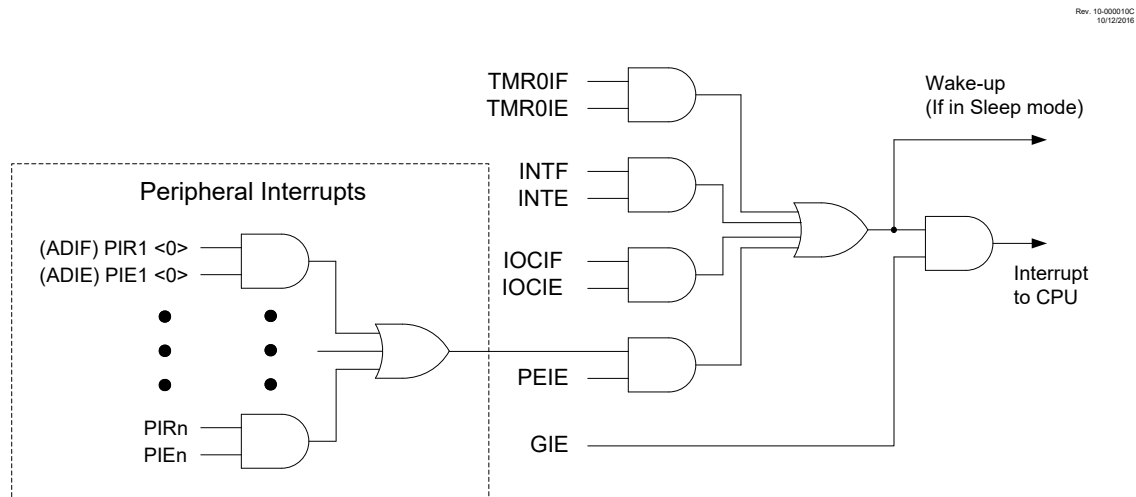
This chapter contains the following information for Interrupts:

- Operation
- Interrupt Latency
- Interrupts During Sleep
- INT Pin
- Automatic Context Saving

Many peripherals produce interrupts. Refer to the corresponding chapters for details.

A block diagram of the interrupt logic is shown below.

**Figure 10-1. Interrupt Logic**



### 10.1 Operation

Interrupts are disabled upon any device Reset. They are enabled by setting the following bits:

- GIE bit of the INTCON register
- Interrupt Enable bit(s) of the PIRx[y] registers for the specific interrupt event(s)
- PEIE bit of the INTCON register (if the Interrupt Enable bit of the interrupt event is contained in the PIRx registers)

The PIR registers contain the individual flag bits for the peripheral interrupts. Due to the number of peripheral interrupt sources, there are 9 PIR registers.

The following events happen when an interrupt event occurs while the GIE bit is set:

- Current prefetched instruction is flushed
- GIE bit is cleared
- Current Program Counter (PC) is pushed onto the stack

- Critical registers are automatically saved to the shadow registers (see “Automatic Context Saving”)
- PC is loaded with the interrupt vector 0004h

The firmware within the Interrupt Service Routine (ISR) should determine the source of the interrupt by polling the interrupt flag bits. The interrupt flag bits must be cleared before exiting the ISR to avoid repeated interrupts. Because the GIE bit is cleared, any interrupt that occurs while executing the ISR will be recorded through its interrupt flag, but will not cause the processor to redirect to the interrupt vector.

The `RETFIE` instruction exits the ISR by popping the previous address from the stack, restoring the saved context from the shadow registers and setting the GIE bit.

For additional information on a specific interrupts operation, refer to its peripheral chapter.



**Important:**

1. Individual interrupt flag bits are set, regardless of the state of any other enable bits.
2. All interrupts will be ignored while the GIE bit is cleared. Any interrupt occurring while the GIE bit is clear will be serviced when the GIE bit is set again.

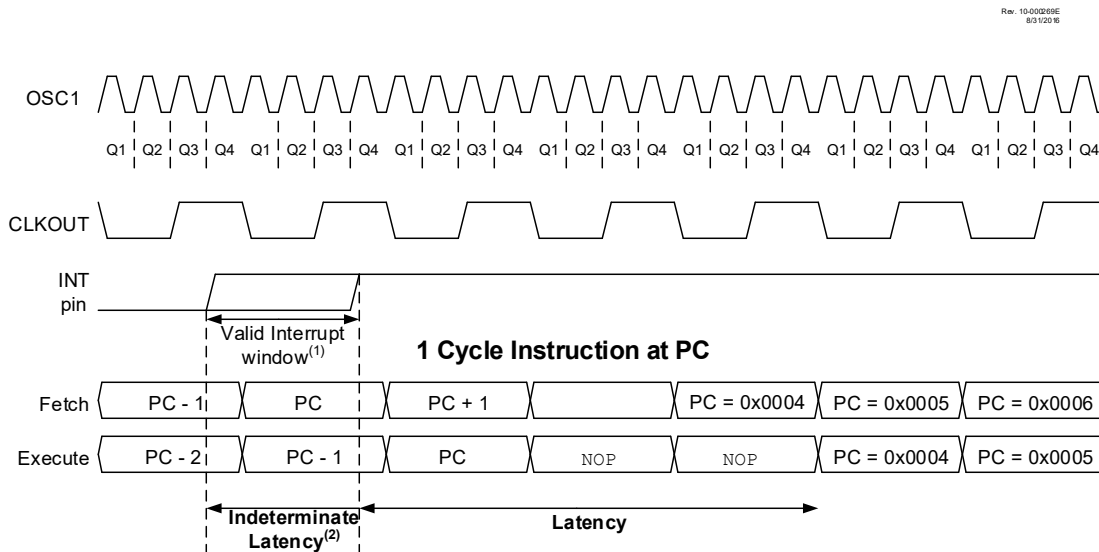
**Related Links**

[10.5 Automatic Context Saving](#)

## 10.2 Interrupt Latency

Interrupt latency is defined as the time from when the interrupt event occurs to the time code execution at the interrupt vector begins. The interrupt is sampled during Q1 of the instruction cycle. The actual interrupt latency then depends on the instruction that is executing at the time the interrupt is detected. See the following figures for more details.

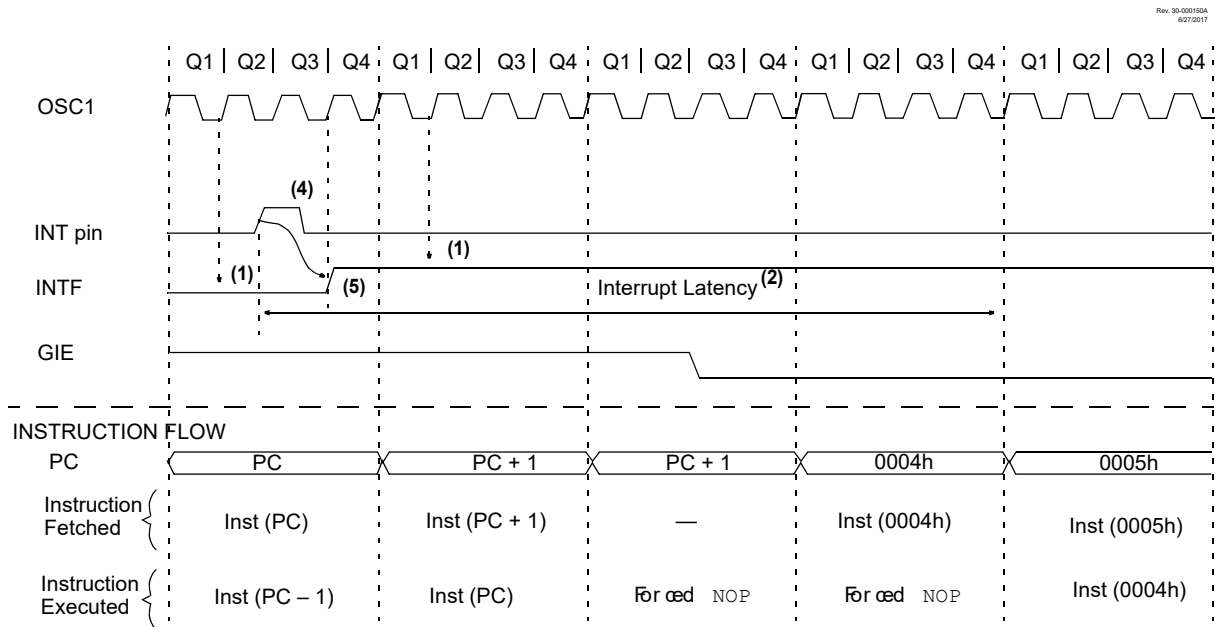
**Figure 10-2. Interrupt Latency**



**Note:**

1. An interrupt may occur at any time during the interrupt window.
2. Since an interrupt may occur any time during the interrupt window, the actual latency can vary.

Figure 10-3. INT Pin Interrupt Timing



**Note:**

1. INTF flag is sampled here (every Q1).
2. Asynchronous interrupt latency = 3-5  $T_{CY}$ . Synchronous latency = 3-4  $T_{CY}$ , where  $T_{CY}$  = instruction cycle time. Latency is the same whether Inst (PC) is a single cycle or a 2-cycle instruction.
3. For minimum width of INT pulse, refer to AC specifications in the “Electrical Specifications” section.
4. INTF may be set any time during the Q4-Q1 cycles.

### 10.3 Interrupts During Sleep

Interrupts can be used to wake from Sleep. To wake from Sleep, the peripheral must be able to operate without the system clock. The interrupt source must have the appropriate Interrupt Enable bit(s) set prior to entering Sleep.

On waking from Sleep, if the GIE bit is also set, the processor will branch to the interrupt vector. Otherwise, the processor will continue executing instructions after the SLEEP instruction. The instruction directly after the SLEEP instruction will always be executed before branching to the ISR.

**Related Links**

[11. Power-Saving Operation Modes](#)

### 10.4 INT Pin

The INT pin can be used to generate an asynchronous edge-triggered interrupt. Refer to Figure 10-3. This interrupt is enabled by setting the INTE bit of the PIE0 register. The INTEDG bit of the INTCON register determines on which edge the interrupt will occur. When the INTEDG bit is set, the rising edge will cause the interrupt. When the INTEDG bit is clear, the falling edge will cause the interrupt. The INTF

---

---

bit of the PIR0 register will be set when a valid edge appears on the INT pin. If the GIE and INTE bits are also set, the processor will redirect program execution to the interrupt vector.

## 10.5 Automatic Context Saving

Upon entering an interrupt, the return PC address is saved on the stack. Additionally, the following registers are automatically saved in the shadow registers:

- W register
- STATUS register (except for  $\overline{TO}$  and  $\overline{PD}$ )
- BSR register
- FSR registers
- PCLATH register

Upon exiting the Interrupt Service Routine, these registers are automatically restored. Any modifications to these registers during the ISR will be lost. If modifications to any of these registers are desired, the corresponding shadow register should be modified and the value will be restored when exiting the ISR. The shadow registers are available in Bank 63 and are readable and writable. Depending on the user's application, other registers may also need to be saved.

### Related Links

[7.10 Register Definitions: Shadow Registers](#)

## 10.6 Register Summary - Interrupt Control

Address	Name	Bit Pos.								
0x070C	PIR0	7:0			TMR0IF	IOCIF				INTF
0x070D	PIR1	7:0	OSFIF	CSWIF					ADTIF	ADIF
0x070E	PIR2	7:0		ZCDIF					C2IF	C1IF
0x070F	PIR3	7:0	RC2IF	TX2IF	RC1IF	TX1IF	BCL2IF	SSP2IF	BCL1IF	SSP1IF
0x0710	PIR4	7:0			TMR6IF	TMR5IF	TMR4IF	TMR3IF	TMR2IF	TMR1IF
0x0711	PIR5	7:0	CLC4IF	CLC3IF	CL24IF	CLC1IF		TMR5GIF	TMR3GIF	TMR1GIF
0x0712	PIR6	7:0				CCP5IF	CCP4IF	CCP3IF	CCP2IF	CCP1IF
0x0713	PIR7	7:0			NVMIF	NCO1IF		CWG3IF	CWG2IF	CWG1IF
0x0714	PIR8	7:0			SMT2PWAIF	SMT2PRAIF	SMT2IF	SMT1PWAIF	SMT1PRAIF	SMT1IF
0x0715	Reserved									
0x0716	PIE0	7:0			TMR0IE	IOCIE				INTE
0x0717	PIE1	7:0	OSFIE	CSWIE					ADTIE	ADIE
0x0718	PIE2	7:0		ZCDIE					C2IE	C1IE
0x0719	PIE3	7:0	RC2IE	TX2IE	RC1IE	TX1IE	BCL2IE	SSP2IE	BCL1IE	SSP1IE
0x071A	PIE4	7:0			TMR6IE	TMR5IE	TMR4IE	TMR3IE	TMR2IE	TMR1IE
0x071B	PIE5	7:0	CLC4IE	CLC3IE	CLC2IE	CLC1IE		TMR5GIE	TMR3GIE	TMR1GIE
0x071C	PIE6	7:0				CCP5IE	CCP4IE	CCP3IE	CCP2IE	CCP1IE
0x071D	PIE7	7:0			NVMIE	NCO1IE		CWG3IE	CWG2IE	CWG1IE
0x071E	PIE8	7:0			SMT2PWAIE	SMT2PRAIE	SMT2IE	SMT1PWAIE	SMT1PRAIE	SMT1IE

## 10.7 Register Definitions: Interrupt Control



10.7.1 INTCON

**Name:** INTCON

**Address:** 0x00B

Interrupt Control Register

Bit	7	6	5	4	3	2	1	0
	GIE	PEIE						INTEDG
Access	R/W	R/W						R/W
Reset	0	0						1

**Bit 7 – GIE** Global Interrupt Enable bit

Value	Description
1	Enables all active interrupts
0	Disables all interrupts

**Bit 6 – PEIE** Peripheral Interrupt Enable bit

Value	Description
1	Enables all active peripheral interrupts
0	Disables all peripheral interrupts

**Bit 0 – INTEDG** External Interrupt Edge Select bit

Value	Description
1	Interrupt on rising edge of INT pin
0	Interrupt on falling edge of INT pin

**Important:** Interrupt flag bits are set when an interrupt condition occurs, regardless of the state of its corresponding enable bit or the global enable bit. User software should ensure the appropriate interrupt flag bits are clear prior to enabling an interrupt. This feature allows for software polling.

10.7.2 PIE0

**Name:** PIE0  
**Address:** 0x716

Peripheral Interrupt Enable Register 0

Bit	7	6	5	4	3	2	1	0
			TMR0IE	IOIE				INTE
Access			R/W	R/W				R/W
Reset			0	0				0

**Bit 5 – TMR0IE** Timer0 Interrupt Enable bit

Value	Description
1	Enabled
0	Disabled

**Bit 4 – IOIE** Interrupt-on-Change Enable bit

Value	Description
1	Enabled
0	Disabled

**Bit 0 – INTE** External Interrupt Enable bit<sup>(1)</sup>

Value	Description
1	Enabled
0	Disabled

**Note:**

1. The External Interrupt INT pin is selected by INTPPS.

**Note:** Bit PEIE of the INTCON register must be set to enable any peripheral interrupt controlled by PIE1-PIE8. Interrupt sources controlled by the PIE0 register do not require PEIE to be set in order to allow interrupt vectoring (when GIE is set).

**Related Links**

[15.9.1 xxxPPS](#)

10.7.3 PIE1

**Name:** PIE1  
**Address:** 0x717

Peripheral Interrupt Enable Register 1

Bit	7	6	5	4	3	2	1	0
	OSFIE	CSWIE					ADTIE	ADIE
Access	R/W	R/W					R/W	R/W
Reset	0	0					0	0

**Bit 7 – OSFIE** Oscillator Fail Interrupt Enable bit

Value	Description
1	Enabled
0	Disabled

**Bit 6 – CSWIE** Clock-Switch Interrupt Enable bit

Value	Description
1	Enabled
0	Disabled

**Bit 1 – ADTIE** ADC Threshold Interrupt Enable bit

Value	Description
1	Enabled
0	Disabled

**Bit 0 – ADIE** ADC Interrupt Enable bit

Value	Description
1	Enabled
0	Disabled

**Note:** Bit PEIE of the INTCON register must be set to enable any peripheral interrupt controlled by registers PIE1-PIE8.

10.7.4 PIE2

**Name:** PIE2  
**Address:** 0x718

Peripheral Interrupt Enable Register 2

Bit	7	6	5	4	3	2	1	0
		ZCDIE					C2IE	C1IE
Access		R/W					R/W	R/W
Reset		0					0	0

**Bit 6 – ZCDIE** Zero-Cross Detect Interrupt Enable bit

Value	Description
1	Enabled
0	Disabled

**Bits 0, 1 – CnIE** Comparator ‘n’ Interrupt Enable bit

Value	Description
1	Enabled
0	Disabled

**Note:** Bit PEIE of the INTCON register must be set to enable any peripheral interrupt controlled by registers PIE1-PIE8.

10.7.5 PIE3

**Name:** PIE3  
**Address:** 0x719

Peripheral Interrupt Enable Register 3

Bit	7	6	5	4	3	2	1	0
	RC2IE	TX2IE	RC1IE	TX1IE	BCL2IE	SSP2IE	BCL1IE	SSP1IE
Access	R/W	R/W	R/W	R/W	R/W	R/W	R/W	R/W
Reset	0	0	0	0	0	0	0	0

**Bits 5, 7 – RCnIE** EUSARTn Receive Interrupt Enable bit

Value	Description
1	Enabled
0	Disabled

**Bits 4, 6 – TXnIE** EUSARTn Transmit Interrupt Enable bit

Value	Description
1	Enabled
0	Disabled

**Bits 1, 3 – BCLnIE** MSSPn Bus Collision Interrupt Enable bit

Value	Description
1	Enabled
0	Disabled

**Bits 0, 2 – SSPnIE** Synchronous Serial Port ‘n’ Interrupt Enable bit

Value	Description
1	Enabled
0	Disabled

**Note:** Bit PEIE of the INTCON register must be set to enable any peripheral interrupt controlled by registers PIE1-PIE8.

10.7.6 PIE4

**Name:** PIE4  
**Address:** 0x71A

Peripheral Interrupt Enable Register 4

Bit	7	6	5	4	3	2	1	0
			TMR6IE	TMR5IE	TMR4IE	TMR3IE	TMR2IE	TMR1IE
Access			R/W	R/W	R/W	R/W	R/W	R/W
Reset			0	0	0	0	0	0

**Bit 5 – TMR6IE** TMR6 to PR6 Match Interrupt Enable bit

Value	Description
1	Enabled
0	Disabled

**Bit 4 – TMR5IE** TMR5 Overflow Interrupt Enable bit

Value	Description
1	Enabled
0	Disabled

**Bit 3 – TMR4IE** TMR4 to PR4 Match Interrupt Enable bit

Value	Description
1	Enabled
0	Disabled

**Bit 2 – TMR3IE** TMR3 Overflow Interrupt Enable bit

Value	Description
1	Enabled
0	Disabled

**Bit 1 – TMR2IE** TMR2 to PR2 Match Interrupt Enable bit

Value	Description
1	Enabled
0	Disabled

**Bit 0 – TMR1IE** TMR1 Overflow Interrupt Enable bit

Value	Description
1	Enabled
0	Disabled

**Note:** Bit PEIE of the INTCON register must be set to enable any peripheral interrupt controlled by registers PIE1-PIE8.

10.7.7 PIE5

**Name:** PIE5  
**Address:** 0x71B

Peripheral Interrupt Enable Register 5

Bit	7	6	5	4	3	2	1	0
	CLC4IE	CLC3IE	CLC2IE	CLC1IE		TMR5GIE	TMR3GIE	TMR1GIE
Access	R/W	R/W	R/W	R/W		R/W	R/W	R/W
Reset	0	0	0	0		0	0	0

**Bit 7 – CLC4IE** CLC4 Interrupt Enable bit

Value	Description
1	Enabled
0	Disabled

**Bit 6 – CLC3IE** CLC3 Interrupt Enable bit

Value	Description
1	Enabled
0	Disabled

**Bit 5 – CLC2IE** CLC2 Interrupt Enable bit

Value	Description
1	Enabled
0	Disabled

**Bit 4 – CLC1IE** CLC1 Interrupt Enable bit

Value	Description
1	Enabled
0	Disabled

**Bit 2 – TMR5GIE** TMR5 Gate Interrupt Enable bit

Value	Description
1	Enabled
0	Disabled

**Bit 1 – TMR3GIE** TMR3 Gate Interrupt Enable bit

Value	Description
1	Enabled
0	Disabled

**Bit 0 – TMR1GIE** TMR1 Gate Interrupt Enable bit

---

---

Value	Description
1	Enabled
0	Disabled

**Note:** Bit PEIE of the INTCON register must be set to enable any peripheral interrupt controlled by registers PIE1-PIE8.



10.7.8 PIE6

**Name:** PIE6  
**Address:** 0x71C

Peripheral Interrupt Enable Register 6

Bit	7	6	5	4	3	2	1	0
				CCP5IE	CCP4IE	CCP3IE	CCP2IE	CCP1IE
Access				R/W	R/W	R/W	R/W	R/W
Reset				0	0	0	0	0

**Bit 4 – CCP5IE** CCP5 Interrupt Enable bit

Value	Description
1	Enabled
0	Disabled

**Bit 3 – CCP4IE** CCP4 Interrupt Enable bit

Value	Description
1	Enabled
0	Disabled

**Bit 2 – CCP3IE** CCP3 Interrupt Enable bit

Value	Description
1	Enabled
0	Disabled

**Bit 1 – CCP2IE** CCP2 Interrupt Enable bit

Value	Description
1	Enabled
0	Disabled

**Bit 0 – CCP1IE** CCP1 Interrupt Enable bit

Value	Description
1	Enabled
0	Disabled

**Note:** Bit PEIE of the INTCON register must be set to enable any peripheral interrupt controlled by registers PIE1-PIE8.

10.7.9 PIE7

**Name:** PIE7  
**Address:** 0x71D

Peripheral Interrupt Enable Register 7

Bit	7	6	5	4	3	2	1	0
			NVMIE	NCO1IE		CWG3IE	CWG2IE	CWG1IE
Access			R/W	R/W		R/W	R/W	R/W
Reset			0	0		0	0	0

**Bit 5 – NVMIE** NVM Interrupt Enable bit

Value	Description
1	Enabled
0	Disabled

**Bit 4 – NCO1IE** NCO Interrupt Enable bit

Value	Description
1	Enabled
0	Disabled

**Bit 2 – CWG3IE** CWG3 Interrupt Enable bit

Value	Description
1	Enabled
0	Disabled

**Bit 1 – CWG2IE** CWG2 Interrupt Enable bit

Value	Description
1	Enabled
0	Disabled

**Bit 0 – CWG1IE** CWG1 Interrupt Enable bit

Value	Description
1	Enabled
0	Disabled

**Note:** Bit PEIE of the INTCON register must be set to enable any peripheral interrupt controlled by registers PIE1-PIE8.

10.7.10 PIE8

**Name:** PIE8  
**Address:** 0x71E

Peripheral Interrupt Enable Register 8

Bit	7	6	5	4	3	2	1	0
			SMT2PWAIE	SMT2PRAIE	SMT2IE	SMT1PWAIE	SMT1PRAIE	SMT1IE
Access			R/W	R/W	R/W	R/W	R/W	R/W
Reset			0	0	0	0	0	0

**Bit 5 – SMT2PWAIE** SMT2 Pulse-width Acquisition Interrupt Enable bit

Value	Description
1	Enabled
0	Disabled

**Bit 4 – SMT2PRAIE** SMT2 Period Acquisition Interrupt Enable bit

Value	Description
1	Enabled
0	Disabled

**Bit 3 – SMT2IE** SMT2 Counter Overflow Interrupt Enable bit

Value	Description
1	Enabled
0	Disabled

**Bit 2 – SMT1PWAIE** SMT1 Pulse-width Acquisition Interrupt Enable bit

Value	Description
1	Enabled
0	Disabled

**Bit 1 – SMT1PRAIE** SMT1 Period Acquisition Interrupt Enable bit

Value	Description
1	Enabled
0	Disabled

**Bit 0 – SMT1IE** SMT1 Counter Overflow Interrupt Enable bit

Value	Description
1	Enabled
0	Disabled

**Note:** Bit PEIE of the INTCON register must be set to enable any peripheral interrupt controlled by registers PIE1-PIE8.

### 10.7.11 PIR0

**Name:** PIR0  
**Address:** 0x70C

Peripheral Interrupt Request (Flag) Register 0

Bit	7	6	5	4	3	2	1	0
			TMR0IF	IOCIF				INTF
Access			R/W/HS	RO				R/W/HS
Reset			0	0				0

**Bit 5 – TMR0IF** Timer0 Interrupt Flag bit

Value	Description
1	TMR0 register has overflowed (must be cleared by software)
0	TMR0 register has not overflowed

**Bit 4 – IOCIF** Interrupt-on-Change Flag bit<sup>(2)</sup>

Value	Description
1	One or more of the IOCAF-IOCEF register bits are currently set, indicating an enabled edge was detected by the IOC module.
0	None of the IOCAF-IOCEF register bits are currently set

**Bit 0 – INTF** External Interrupt Flag bit<sup>(1)</sup>

Value	Description
1	External Interrupt has occurred
0	External Interrupt has not occurred

**Note:**

1. The External Interrupt INT pin is selected by INTPPS.
2. The IOCIF bit is the logical OR of all the IOCAF-IOCEF flags. Therefore, to clear the IOCIF flag, application firmware must clear all of the lower level IOCAF-IOCEF register bits.

**Note:** Interrupt flag bits are set when an interrupt condition occurs, regardless of the state of its corresponding enable bit or the Global Enable bit, GIE, of the INTCON appropriate interrupt flag bits are clear prior to enabling an interrupt.

**Related Links**

[15.9.1 xxxPPS](#)

10.7.12 PIR1

**Name:** PIR1  
**Address:** 0x70D

Peripheral Interrupt Request (Flag) Register 1

Bit	7	6	5	4	3	2	1	0
	OSFIF	CSWIF					ADTIF	ADIF
Access	R/W/HS	R/W/HS					R/W/HS	R/W/HS
Reset	0	0					0	0

**Bit 7 – OSFIF** Oscillator Fail Interrupt Flag bit

Value	Description
1	Oscillator fail-safe interrupt has occurred (must be cleared in software)
0	No oscillator fail-safe interrupt

**Bit 6 – CSWIF** Clock-Switch Complete Interrupt Flag bit

Value	Description
1	The clock switch module indicates an interrupt condition and is ready to complete the clock switch operation (must be cleared in software)
0	The clock switch does not indicate an interrupt condition

**Bit 1 – ADTIF** ADC Threshold Interrupt Flag bit

Value	Description
1	An A/D conversion or complex operation has completed (must be cleared in software)
0	An A/D conversion or complex operation is not complete

**Bit 0 – ADIF** ADC Interrupt Flag bit

Value	Description
1	An A/D conversion or complex operation has completed (must be cleared in software)
0	An A/D conversion or complex operation is not complete

**Note:** Interrupt flag bits are set when an interrupt condition occurs, regardless of the state of its corresponding enable bit or the Global Enable bit, GIE, of the INTCON appropriate interrupt flag bits are clear prior to enabling an interrupt.

10.7.13 PIR2

**Name:** PIR2  
**Address:** 0x70E

Peripheral Interrupt Request (Flag) Register 2

Bit	7	6	5	4	3	2	1	0
		ZCDIF					C2IF	C1IF
Access		R/W/HS					R/W/HS	R/W/HS
Reset		0					0	0

**Bit 6 – ZCDIF** Zero-Cross Detect Interrupt Flag bit

Value	Description
1	An enabled rising and/or falling ZCD1 event has been detected (must be cleared in software)
0	No ZCD1 event has occurred

**Bits 0, 1 – CnIF** Comparator ‘n’ Interrupt Flag bit

Value	Description
1	Comparator Cn interrupt asserted (must be cleared in software)
0	Comparator Cn interrupt not asserted

**Note:** Interrupt flag bits are set when an interrupt condition occurs, regardless of the state of its corresponding enable bit or the Global Enable bit, GIE, of the INTCON appropriate interrupt flag bits are clear prior to enabling an interrupt.

10.7.14 PIR3

**Name:** PIR3  
**Address:** 0x70F

Peripheral Interrupt Request (Flag) Register 3

Bit	7	6	5	4	3	2	1	0
	RC2IF	TX2IF	RC1IF	TX1IF	BCL2IF	SSP2IF	BCL1IF	SSP1IF
Access	RO/HS	RO/HS	RO/HS	RO/HS	R/W/HS	R/W/HS	R/W/HS	R/W/HS
Reset	0	0	0	0	0	0	0	0

**Bits 5, 7 – RCnIF** EUSARTn Receive Interrupt Flag bit<sup>(1)</sup>

Value	Description
1	The EUSARTn receive buffer is not empty (contains at least one byte)
0	The EUSARTn receive buffer is empty

**Bits 4, 6 – TXnIF** EUSARTn Transmit Interrupt Flag bit<sup>(2)</sup>

Value	Description
1	The EUSARTn transmit buffer contains at least one unoccupied space
0	The EUSARTn transmit buffer is currently full. The application firmware should not write to TXnREG again, until more room becomes available in the transmit buffer.

**Bits 1, 3 – BCLnIF** MSSPn Bus Collision Interrupt Flag bit

Value	Description
1	A bus collision was detected (must be cleared in software)
0	No bus collision was detected

**Bits 0, 2 – SSPnIF** Synchronous Serial Port ‘n’ Interrupt Flag bit

Value	Description
1	The Transmission/Reception/Bus Condition is complete (must be cleared in software)
0	Waiting for the Transmission/Reception/Bus Condition in progress

**Note:**

1. The RCnIF flag is a read-only bit. To clear the RCnIF flag, the firmware must read from RCnREG enough times to remove all bytes from the receive buffer.
2. The TXnIF flag is a read-only bit, indicating if there is room in the transmit buffer. To clear the TXnIF flag, the firmware must write enough data to TXnREG to completely fill all available bytes in the buffer. The TXnIF flag does not indicate transmit completion (use TRMT for this purpose instead).

**Note:** Interrupt flag bits are set when an interrupt condition occurs, regardless of the state of its corresponding enable bit or the Global Enable bit, GIE, of the INTCON appropriate interrupt flag bits are clear prior to enabling an interrupt.

10.7.15 PIR4

**Name:** PIR4  
**Address:** 0x710

Peripheral Interrupt Request (Flag) Register 4

Bit	7	6	5	4	3	2	1	0
			TMR6IF	TMR5IF	TMR4IF	TMR3IF	TMR2IF	TMR1IF
Access			R/W/HS	R/W/HS	R/W/HS	R/W/HS	R/W/HS	R/W/HS
Reset			0	0	0	0	0	0

**Bit 5 – TMR6IF** TMR6 to PR6 Match Interrupt Flag bit

Value	Description
1	The TMR6 postscaler overflowed, or in 1:1 mode, a TMR6 to PR6 match occurred (must be cleared in software)
0	No TMR6 event has occurred

**Bit 4 – TMR5IF** TMR5 Overflow Interrupt Flag bit

Value	Description
1	TMR5 register overflowed (must be cleared in software)
0	TMR5 register did not overflow

**Bit 3 – TMR4IF** TMR4 to PR4 Match Interrupt Flag bit

Value	Description
1	The TMR4 postscaler overflowed, or in 1:1 mode, a TMR4 to PR4 match occurred (must be cleared in software)
0	No TMR4 event has occurred

**Bit 2 – TMR3IF** TMR3 Overflow Interrupt Flag bit

Value	Description
1	TMR3 register overflowed (must be cleared in software)
0	TMR3 register did not overflow

**Bit 1 – TMR2IF** TMR2 to PR2 Match Interrupt Flag bit

Value	Description
1	The TMR2 postscaler overflowed, or in 1:1 mode, a TMR2 to PR2 match occurred (must be cleared in software)
0	No TMR2 event has occurred

**Bit 0 – TMR1IF** TMR1 Overflow Interrupt Flag bit

Value	Description
1	TMR1 register overflowed (must be cleared in software)
0	TMR1 register did not overflow



**Note:** Interrupt flag bits are set when an interrupt condition occurs, regardless of the state of its corresponding enable bit or the Global Enable bit, GIE, of the INTCON appropriate interrupt flag bits are clear prior to enabling an interrupt.

10.7.16 PIR5

**Name:** PIR5  
**Address:** 0x711

Peripheral Interrupt Request (Flag) Register 5

Bit	7	6	5	4	3	2	1	0
	CLC4IF	CLC3IF	CL24IF	CLC1IF		TMR5GIF	TMR3GIF	TMR1GIF
Access	R/W/HS	R/W/HS	R/W/HS	R/W/HS		R/W/HS	R/W/HS	R/W/HS
Reset	0	0	0	0		0	0	0

**Bit 7 – CLC4IF** CLC4 Interrupt Flag bit

Value	Description
1	A CLC4OUT interrupt condition has occurred (must be cleared in software)
0	No CLC4 interrupt event has occurred

**Bit 6 – CLC3IF** CLC3 Interrupt Flag bit

Value	Description
1	A CLC3OUT interrupt condition has occurred (must be cleared in software)
0	No CLC3 interrupt event has occurred

**Bit 5 – CL24IF** CLC2 Interrupt Flag bit

Value	Description
1	A CLC2OUT interrupt condition has occurred (must be cleared in software)
0	No CLC2 interrupt event has occurred

**Bit 4 – CLC1IF** CLC1 Interrupt Flag bit

Value	Description
1	A CLC1OUT interrupt condition has occurred (must be cleared in software)
0	No CLC1 interrupt event has occurred

**Bit 2 – TMR5GIF** TMR5 Gate Interrupt Flag bit

Value	Description
1	The Timer5 Gate has gone inactive (the acquisition is complete)
0	The Timer5 Gate has not gone inactive

**Bit 1 – TMR3GIF** TMR3 Gate Interrupt Flag bit

Value	Description
1	The Timer3 Gate has gone inactive (the acquisition is complete)
0	The Timer3 Gate has not gone inactive

**Bit 0 – TMR1GIF** TMR1 Gate Interrupt Flag bit

---

---

Value	Description
1	The Timer1 Gate has gone inactive (the acquisition is complete)
0	The Timer1 Gate has not gone inactive

**Note:** Interrupt flag bits are set when an interrupt condition occurs, regardless of the state of its corresponding enable bit or the Global Enable bit, GIE, of the INTCON appropriate interrupt flag bits are clear prior to enabling an interrupt.

10.7.17 PIR6

**Name:** PIR6  
**Address:** 0x712

PIR6 Peripheral Interrupt Request (Flag) Register 6

Bit	7	6	5	4	3	2	1	0
				CCP5IF	CCP4IF	CCP3IF	CCP2IF	CCP1IF
Access				R/W/HS	R/W/HS	R/W/HS	R/W/HS	R/W/HS
Reset				0	0	0	0	0

**Bit 4 – CCP5IF** CCP5 Interrupt Flag bit

Value	Condition	Description
1	Capture mode	Capture occurred (must be cleared in software)
0	Capture mode	Capture did not occur
1	Compare mode	Compare match occurred (must be cleared in software)
0	Compare mode	Compare match did not occur
1	PWM mode	Output trailing edge occurred (must be cleared in software)
0	PWM mode	Output trailing edge did not occur

**Bit 3 – CCP4IF** CCP4 Interrupt Flag bit

Value	Condition	Description
1	Capture mode	Capture occurred (must be cleared in software)
0	Capture mode	Capture did not occur
1	Compare mode	Compare match occurred (must be cleared in software)
0	Compare mode	Compare match did not occur
1	PWM mode	Output trailing edge occurred (must be cleared in software)
0	PWM mode	Output trailing edge did not occur

**Bit 2 – CCP3IF** CCP3 Interrupt Flag bit

Value	Condition	Description
1	Capture mode	Capture occurred (must be cleared in software)
0	Capture mode	Capture did not occur
1	Compare mode	Compare match occurred (must be cleared in software)
0	Compare mode	Compare match did not occur
1	PWM mode	Output trailing edge occurred (must be cleared in software)
0	PWM mode	Output trailing edge did not occur

**Bit 1 – CCP2IF** CCP2 Interrupt Flag bit

Value	Condition	Description
1	Capture mode	Capture occurred (must be cleared in software)
0	Capture mode	Capture did not occur
1	Compare mode	Compare match occurred (must be cleared in software)
0	Compare mode	Compare match did not occur

Value	Condition	Description
1	PWM mode	Output trailing edge occurred (must be cleared in software)
0	PWM mode	Output trailing edge did not occur

**Bit 0 – CCP1IF** CCP1 Interrupt Flag bit

Value	Condition	Description
1	Capture mode	Capture occurred (must be cleared in software)
0	Capture mode	Capture did not occur
1	Compare mode	Compare match occurred (must be cleared in software)
0	Compare mode	Compare match did not occur
1	PWM mode	Output trailing edge occurred (must be cleared in software)
0	PWM mode	Output trailing edge did not occur

**Note:** Interrupt flag bits are set when an interrupt condition occurs, regardless of the state of its corresponding enable bit or the Global Enable bit, GIE, of the INTCON appropriate interrupt flag bits are clear prior to enabling an interrupt.

10.7.18 PIR7

**Name:** PIR7  
**Address:** 0x713

Peripheral Interrupt Request (Flag) Register 7

Bit	7	6	5	4	3	2	1	0
			NVMIF	NCO1IF		CWG3IF	CWG2IF	CWG1IF
Access			R/W/HS	R/W/HS		R/W/HS	R/W/HS	R/W/HS
Reset			0	0		0	0	0

**Bit 5 – NVMIF** NVM Interrupt Flag bit

Value	Description
1	The requested NVM operation has completed
0	NVM interrupt not asserted

**Bit 4 – NCO1IF** Numerically Controlled Oscillator (NCO) Interrupt Flag bit

Value	Description
1	The NCO has rolled over
0	No NCO interrupt event has occurred

**Bit 2 – CWG3IF** CWG3 Interrupt Flag bit

Value	Description
1	CWG3 has gone into shutdown
0	CWG3 is operating normally, or interrupt cleared

**Bit 1 – CWG2IF** CWG2 Interrupt Flag bit

Value	Description
1	CWG2 has gone into shutdown
0	CWG2 is operating normally, or interrupt cleared

**Bit 0 – CWG1IF** CWG1 Interrupt Flag bit

Value	Description
1	CWG1 has gone into shutdown
0	CWG1 is operating normally, or interrupt cleared

**Note:** Interrupt flag bits are set when an interrupt condition occurs, regardless of the state of its corresponding enable bit or the Global Enable bit, GIE, of the INTCON appropriate interrupt flag bits are clear prior to enabling an interrupt.

10.7.19 PIR8

**Name:** PIR8  
**Address:** 0x714

Peripheral Interrupt Request (Flag) Register 8

Bit	7	6	5	4	3	2	1	0
			SMT2PWAIF	SMT2PRAIF	SMT2IF	SMT1PWAIF	SMT1PRAIF	SMT1IF
Access			R/W/HS	R/W/HS	R/W/HS	R/W/HS	R/W/HS	R/W/HS
Reset			0	0	0	0	0	0

**Bit 5 – SMT2PWAIF** SMT2 Pulse-Width Acquisition Interrupt Flag bit

Value	Description
1	Interrupt has occurred (must be cleared by software)
0	Interrupt event has not occurred

**Bit 4 – SMT2PRAIF** SMT2 Period Acquisition Interrupt Flag bit

Value	Description
1	Interrupt has occurred (must be cleared by software)
0	Interrupt event has not occurred

**Bit 3 – SMT2IF** SMT2 Interrupt Flag bit

Value	Description
1	Interrupt has occurred (must be cleared by software)
0	Interrupt event has not occurred

**Bit 2 – SMT1PWAIF** SMT1 Pulse-Width Acquisition Interrupt Flag bit

Value	Description
1	Interrupt has occurred (must be cleared by software)
0	Interrupt event has not occurred

**Bit 1 – SMT1PRAIF** SMT1 Period Acquisition Interrupt Flag bit

Value	Description
1	Interrupt has occurred (must be cleared by software)
0	Interrupt event has not occurred

**Bit 0 – SMT1IF** SMT1 Interrupt Flag bit

Value	Description
1	Interrupt has occurred (must be cleared by software)
0	Interrupt event has not occurred

**Note:** Interrupt flag bits are set when an interrupt condition occurs, regardless of the state of its corresponding enable bit or the Global Enable bit, GIE, of the INTCON appropriate interrupt flag bits are clear prior to enabling an interrupt.

## 11. Power-Saving Operation Modes

The purpose of the Power-Down modes is to reduce power consumption. There are three Power-Down modes:

- Doze mode
- Sleep mode
- Idle mode

### 11.1 Doze Mode

Doze mode allows for power saving by reducing CPU operation and program memory (PFM) access, without affecting peripheral operation. Doze mode differs from Sleep mode because the bandgap and system oscillators continue to operate, while only the CPU and PFM are affected. The reduced execution saves power by eliminating unnecessary operations within the CPU and memory.

When the Doze Enable bit is set (**DOZEN** = 1), the CPU executes only one instruction cycle out of every N cycles as defined by the **DOZE** bits. For example, if **DOZE** = 001, the instruction cycle ratio is 1:4. The CPU and memory execute for one instruction cycle and then lay idle for three instruction cycles. During the unused cycles, the peripherals continue to operate at the system clock speed.

#### Related Links

[11.5.2 CPUDOZE](#)

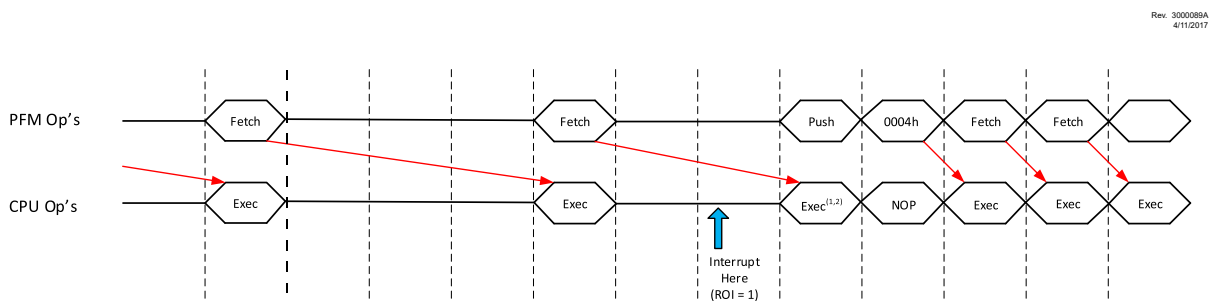
#### 11.1.1 Doze Operation

The Doze operation is illustrated in [Figure 11-1](#). For this example:

- Doze enabled (**DOZEN** = 1)
- **DOZE** = 001 (1:4) ratio
- Recover-on-Interrupt enabled (**ROI** = 1)

As with normal operation, the PFM fetches for the next instruction cycle. The Q-clocks to the peripherals continue throughout.

**Figure 11-1. DOZE MODE OPERATION EXAMPLE (DOZE<2:0> = 001, 1:4)**



#### Note:

1. Multi-cycle instructions are executed to completion before fetching 0004h.
2. If the pre-fetched instruction clears GIE, the ISR will not occur, but DOZEN is still cleared and the CPU will resume execution at full speed.



### 11.1.2 Interrupts During Doze

System behavior if an interrupt occurs during DOZE can be configured using the Recover-on-Interrupt (ROI) bit and the Doze-on-Exit (DOE) bit. Refer to the table below for details about system behavior in all cases for a transition from Main to ISR back to Main.

**Table 11-1. Interrupts During DOZE**

DOZEN	ROI	Code Flow		
		Main	ISR <sup>(1)</sup>	Return to Main
0	0	Normal Operation	Normal operation and DOE = DOZEN (in hardware) DOZEN = 0 (unchanged)	
0	1	Normal Operation	Normal operation and DOE = DOZEN (in hardware) DOZEN = 0 (unchanged)	If DOE = 1 when return from interrupt: DOZE operation and DOZEN = 1 (in hardware)  If DOE = 0 when return from interrupt: Normal operation and DOZEN = 0 (in hardware)
1	0	DOZE operation	DOZE operation and DOE = DOZEN (in hardware) DOZEN = 1 (unchanged)	
1	1	DOZE operation	Normal operation and DOE = DOZEN (in hardware) DOZEN = 0 (unchanged)	

**Note:**

1. User software can change DOE bit in the ISR.

## 11.2 Sleep Mode

Sleep mode is entered by executing the SLEEP instruction, while the Idle Enable (IDLEN) bit of the CPUDOZE register is clear (IDLEN = 0).

Upon entering Sleep mode, the following conditions exist:

1. WDT will be cleared but keeps running if enabled for operation during Sleep
2. The  $\overline{PD}$  bit of the STATUS register is cleared
3. The  $\overline{TO}$  bit of the STATUS register is set
4. The CPU clock is disabled
5. LFINTOSC, SOSC, HFINTOSC and ADCRC are unaffected and peripherals using them may continue operation in Sleep.
6. I/O ports maintain the status they had before Sleep was executed (driving high, low, or high-impedance)
7. Resets other than WDT are not affected by Sleep mode

Refer to individual chapters for more details on peripheral operation during Sleep.

To minimize current consumption, the following conditions should be considered:

- I/O pins should not be floating
- External circuitry sinking current from I/O pins
- Internal circuitry sourcing current from I/O pins
- Current draw from pins with internal weak pull-ups
- Modules using any oscillator

I/O pins that are high-impedance inputs should be pulled to  $V_{DD}$  or  $V_{SS}$  externally to avoid switching currents caused by floating inputs.

Examples of internal circuitry that might be sourcing current include modules such as the DAC and FVR modules.

**Related Links**

[11.2.3 Low-Power Sleep Mode](#)

[7.8.4 STATUS](#)

[18. \(FVR\) Fixed Voltage Reference](#)

[21. \(DAC\) 5-Bit Digital-to-Analog Converter Module](#)

### 11.2.1 Wake-up from Sleep

The device can wake-up from Sleep through one of the following events:

1. External Reset input on  $\overline{MCLR}$  pin, if enabled.
2. BOR Reset, if enabled.
3. POR Reset.
4. Windowed Watchdog Timer, if enabled.
5. Any external interrupt.
6. Interrupts by peripherals capable of running during Sleep (see individual peripheral for more information).

The first three events will cause a device Reset. The last three events are considered a continuation of program execution. To determine whether a device Reset or wake-up event occurred, refer to the “*Memory Execution Violation*” section.

When the `SLEEP` instruction is being executed, the next instruction (`PC + 1`) is prefetched. For the device to wake-up through an interrupt event, the corresponding interrupt enable bit must be enabled. Wake-up will occur regardless of the state of the GIE bit. If the GIE bit is disabled, the device continues execution at the instruction after the `SLEEP` instruction. If the GIE bit is enabled, the device executes the instruction after the `SLEEP` instruction, the device will then call the Interrupt Service Routine. In cases where the execution of the instruction following `SLEEP` is not desirable, the user should have a `NOP` after the `SLEEP` instruction.

The WDT is cleared when the device wakes-up from Sleep, regardless of the source of wake-up.

**Related Links**

[8.11 Memory Execution Violation](#)

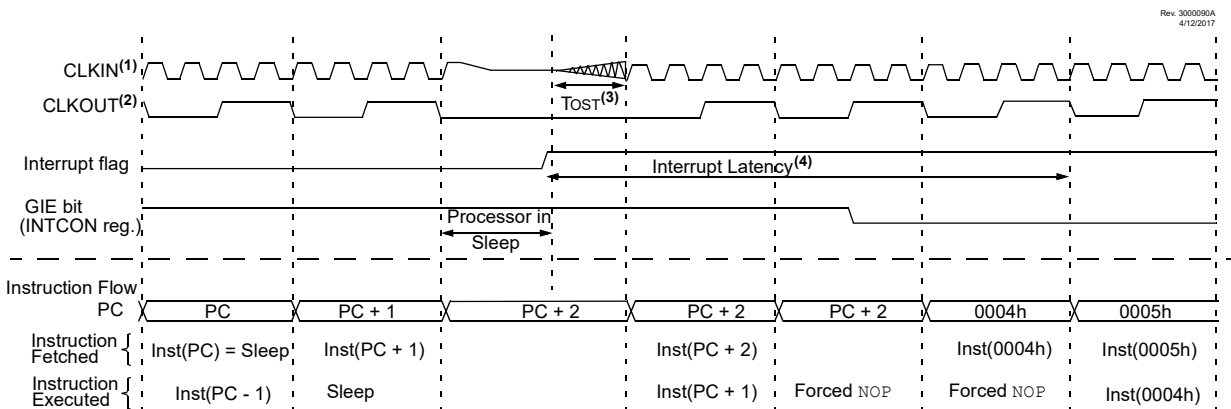
### 11.2.2 Wake-up Using Interrupts

When global interrupts are disabled (GIE cleared) and any interrupt source, with the exception of the clock switch interrupt, has both its interrupt enable bit and interrupt flag bit set, one of the following will occur:

- If the interrupt occurs before the execution of a `SLEEP` instruction
  - `SLEEP` instruction will execute as a `NOP`
  - `WDT` and `WDT` prescaler will not be cleared
  - $\overline{TO}$  bit of the `STATUS` register will not be set
  - $\overline{PD}$  bit of the `STATUS` register will not be cleared
- If the interrupt occurs during or after the execution of a `SLEEP` instruction
  - `SLEEP` instruction will be completely executed
  - Device will immediately wake-up from Sleep
  - `WDT` and `WDT` prescaler will be cleared
  - $\overline{TO}$  bit of the `STATUS` register will be set
  - $\overline{PD}$  bit of the `STATUS` register will be cleared

Even if the flag bits were checked before executing a `SLEEP` instruction, it may be possible for flag bits to become set before the `SLEEP` instruction completes. To determine whether a `SLEEP` instruction executed, test the  $\overline{PD}$  bit. If the  $\overline{PD}$  bit is set, the `SLEEP` instruction was executed as a `NOP`.

**Figure 11-2. WAKE-UP FROM SLEEP THROUGH INTERRUPT**



**Note:**

1. External clock. High, Medium, Low mode assumed.
2. `CLKOUT` is shown here for timing reference.
3.  $T_{OST} = 1024 T_{OSC}$ . This delay does not apply to `EC` and `INTOSC` Oscillator modes.
4. `GIE` = 1 assumed. In this case after wake-up, the processor calls the `ISR` at `0004h`. If `GIE` = 0, execution will continue in-line.

**11.2.3 Low-Power Sleep Mode**

The PIC16(L)F18455/56 devices contain an internal Low Dropout (LDO) voltage regulator, which allows the device I/O pins to operate at voltages up to 5.5V while the internal device logic operates at a lower voltage. The LDO and its associated reference circuitry must remain active when the device is in Sleep mode.

The PIC16(L)F18455/56 devices allow the user to optimize the operating current in Sleep, depending on the application requirements.

Low-Power Sleep mode can be selected by setting the `VREGPM` bit of the `VREGCON` register. Depending on the configuration of these bits, the LDO and reference circuitry are placed in a low-power state when the device is in Sleep.

### 11.2.3.1 Sleep Current vs. Wake-up Time

In the default operating mode, the LDO and reference circuitry remain in the normal configuration while in Sleep. The device is able to exit Sleep mode quickly since all circuits remain active. In Low-Power Sleep mode, when waking-up from Sleep, an extra delay time is required for these circuits to return to the normal configuration and stabilize.

The Low-Power Sleep mode is beneficial for applications that stay in Sleep mode for long periods of time. The Normal mode is beneficial for applications that need to wake from Sleep quickly and frequently.

### 11.2.3.2 Peripheral Usage in Sleep

Some peripherals that can operate in Sleep mode will not operate properly with the Low-Power Sleep mode selected. The Low-Power Sleep mode is intended for use with these peripherals:

- Brown-out Reset (BOR)
- Windowed Watchdog Timer (WWDT)
- External interrupt pin/Interrupt-On-Change pins
- Timer1 (with external clock source)

It is the responsibility of the end user to determine what is acceptable for their application when setting the VREGPM settings in order to ensure operation in Sleep.



**Important:** The LF devices do not have a configurable Low-Power Sleep mode. LFs are unregulated devices and are always in the lowest power state when in Sleep, with no wake-up time penalty. These devices have a lower maximum  $V_{DD}$  and I/O voltage than the F devices.

---

## 11.3 Idle Mode

When the Idle Enable (IDLEN) bit is clear (IDLEN = 0), the `SLEEP` instruction will put the device into full Sleep mode. When IDLEN is set (IDLEN = 1), the `SLEEP` instruction will put the device into IDLE mode. In IDLE mode, the CPU and memory operations are halted, but the peripheral clocks continue to run. This mode is similar to DOZE mode, except that in IDLE both the CPU and program memory are shut off.



**Important:** Peripherals using  $F_{OSC}$  will continue running while in Idle (but not in Sleep). Peripherals using HFINTOSC:LFINTOSC will continue running in both Idle and Sleep.

---



**Important:** If  $\overline{CLKOUTEN}$  is enabled ( $\overline{CLKOUTEN} = 0$ , Configuration Word 1), the output will continue operating while in Idle.

---

### 11.3.1 Idle and Interrupts

IDLE mode ends when an interrupt occurs (even if GIE = 0), but IDLEN is not changed. The device can re-enter IDLE by executing the `SLEEP` instruction.

If Recover-on-Interrupt is enabled (ROI = 1), the interrupt that brings the device out of Idle also restores full-speed CPU execution when doze is also enabled.

### 11.3.2 Idle and WWDT

When in Idle, the WWDT Reset is blocked and will instead wake the device. The WWDT wake-up is not an interrupt, therefore ROI does not apply.



**Important:** The WWDT can bring the device out of Idle, in the same way it brings the device out of Sleep. The DOZEN bit is not affected.

---

### 11.4 Register Summary - Power Savings Control

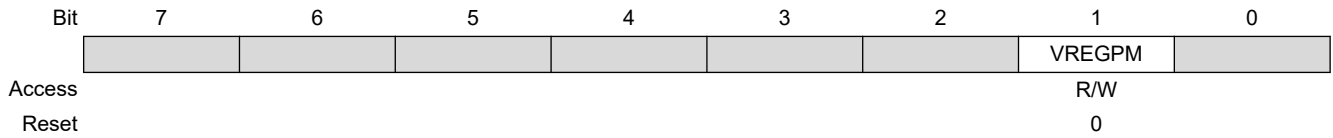
Address	Name	Bit Pos.							
0x0812	VREGCON	7:0							VREGPM
0x0813 ...	Reserved								
0x088B									
0x088C	CPUDOZE	7:0	IDLEN	DOZEN	ROI	DOE			DOZE[2:0]

### 11.5 Register Definitions: Power Savings Control

**11.5.1 VREGCON**

**Name:** VREGCON  
**Address:** 0x812

Voltage Regulator Control Register



**Bit 1 – VREGPM** Voltage Regulator Power Mode Selection bit  
 This register is available only for F devices.

Value	Description
1	Low-Power Sleep mode enabled in Sleep. Draws lowest current in Sleep, slower wake-up
0	Normal Power mode enabled in Sleep. Draws higher current in Sleep, faster wake-up

### 11.5.2 CPUDOZE

**Name:** CPUDOZE  
**Address:** 0x88C

Doze and Idle Register

Bit	7	6	5	4	3	2	1	0
	IDLEN	DOZEN	ROI	DOE		DOZE[2:0]		
Access	R/W	R/W/HC/HS	R/W	R/W/HC/HS		R/W	R/W	R/W
Reset	0	0	0	0		0	0	0

#### Bit 7 – IDLEN Idle Enable bit

Value	Description
1	A SLEEP instruction places device into IDLE mode
0	A SLEEP instruction places the device into Sleep mode

#### Bit 6 – DOZEN Doze Enable bit<sup>(1)</sup>

Value	Description
1	Places devices into DOZE setting
0	Places devices into Normal mode

#### Bit 5 – ROI Recover-on-Interrupt bit<sup>(1)</sup>

Value	Description
1	Entering the Interrupt Service Routine (ISR) makes DOZEN = 0
0	Entering the Interrupt Service Routine (ISR) does not change DOZEN

#### Bit 4 – DOE Doze-on-Exit bit<sup>(1)</sup>

Value	Description
1	Executing the ISR makes DOZEN = 1
0	Exiting the ISR does not change DOZEN

#### Bits 2:0 – DOZE[2:0] Ratio of CPU Instruction Cycles to Peripheral Instruction Cycles

Value	Description
111	1:256
110	1:128
101	1:64
100	1:32
011	1:16
010	1:8
001	1:4
000	1:2

**Note:**

1. See the link below for more details.



**Related Links**

[11.1.2 Interrupts During Doze](#)

## 12. (WWDT) Windowed Watchdog Timer

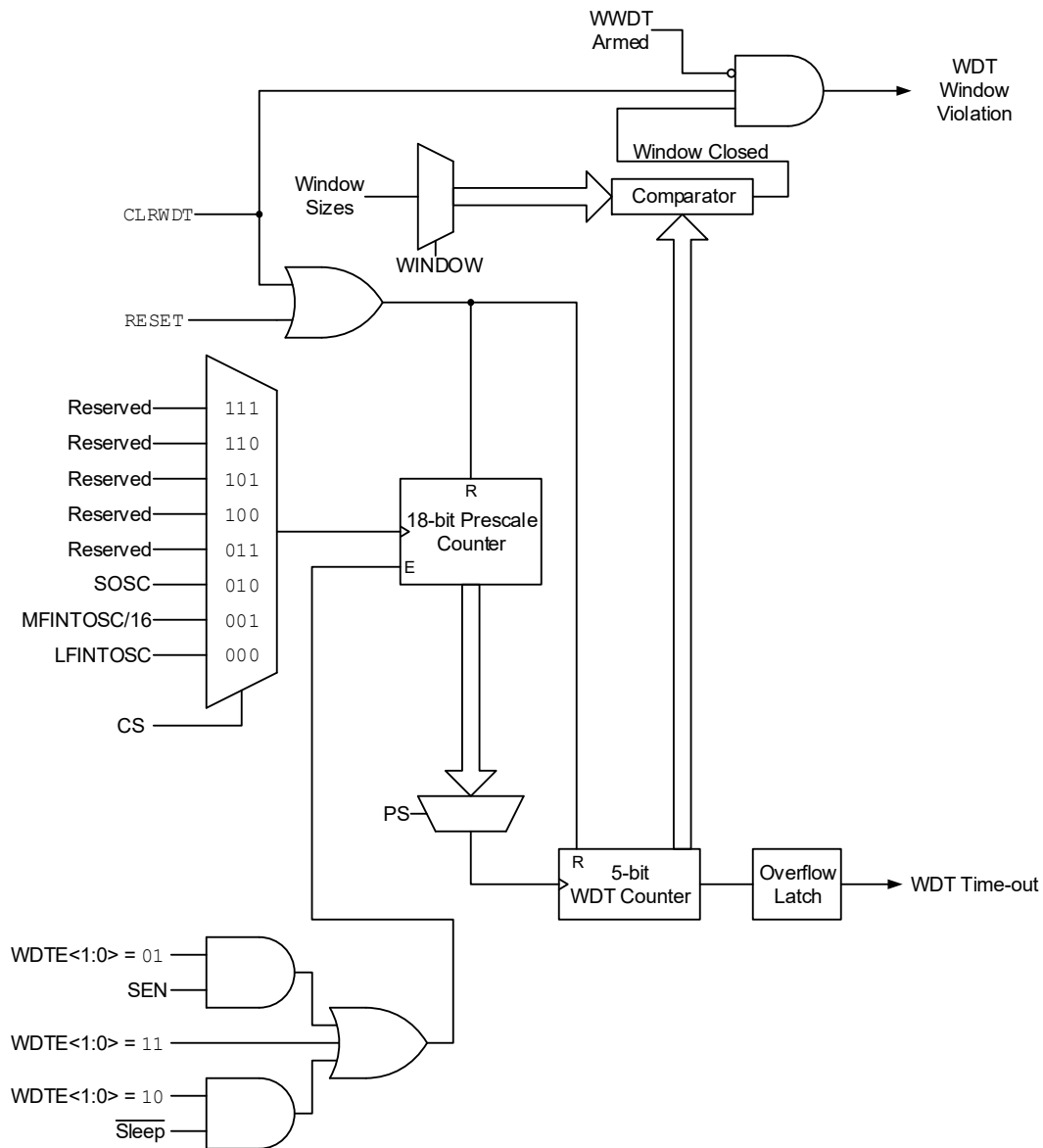
The Watchdog Timer (WDT) is a system timer that generates a Reset if the firmware does not issue a `CLRWDT` instruction within the time-out period. The Watchdog Timer is typically used to recover the system from unexpected events. The Windowed Watchdog Timer (WWDT) differs in that `CLRWDT` instructions are only accepted when they are performed within a specific window during the time-out period.

The WWDT has the following features:

- Selectable clock source
- Multiple operating modes
  - WWDT is always on
  - WWDT is off when in Sleep
  - WWDT is controlled by software
  - WWDT is always off
- Configurable time-out period is from 1 ms to 256s (nominal)
- Configurable window size from 12.5% to 100% of the time-out period
- Multiple Reset conditions

Figure 12-1. Windowed Watchdog Timer Block Diagram

Rev. 10-000 152A  
1/2/2014



## 12.1 Independent Clock Source

The WWDT can derive its time base from either the 31 kHz LFINTOSC or 31.25 kHz MFINTOSC internal oscillators, depending on the value of WDTE Configuration bits.

If WDTE = 'b1x, then the clock source will be enabled depending on the WDTCCS Configuration bits.

If WDTE = 'b01, the SEN bit should be set by software to enable WWDT, and the clock source is enabled by the WDTCS bits.

Time intervals in this chapter are based on a minimum nominal interval of 1 ms. See “*Electrical Specifications*” for LFINTOSC and MFINTOSC tolerances.

**Related Links**

[4.7.3 CONFIG3](#)

[42.4.2 Internal Oscillator Parameters\(1\)](#)

**12.2 WWDT Operating Modes**

The Windowed Watchdog Timer module has four operating modes controlled by the WDTE bits in Configuration Words. See [Table 12-1](#).

**12.2.1 WWDT Is Always On**

When the WDTE bits of Configuration Words are set to '11', the WWDT is always on.

WWDT protection is active during Sleep.

**12.2.2 WWDT Is Off in Sleep**

When the WDTE bits of Configuration Words are set to '10', the WWDT is on, except in Sleep.

WWDT protection is not active during Sleep.

**12.2.3 WWDT Controlled by Software**

When the WDTE bits of Configuration Words are set to '01', the WWDT is controlled by the [SEN](#) bit.

WWDT protection is unchanged by Sleep. See the following table for more details.

**Table 12-1. WWDT Operating Modes**

WDTE<1:0>	SEN	Device Mode	WWDT Mode
11	X	X	Active
10	X	Awake	Active
		Sleep	Disabled
01	1	X	Active
	0	X	Disabled
00	X	X	Disabled

**12.3 Time-out Period**

If the WDTCPSC Configuration bits default to 0'b111111, then the [WDTPS](#) bits set the time-out period from 1 ms to 256 seconds (nominal). If any value other than the default value is assigned to WDTCPSC Configuration bits, then the timer period will be based on the WDTCPSC bits in the CONFIG3 register. After a Reset, the default time-out period is 2s.

**Related Links**

[4.7.3 CONFIG3](#)

**12.4 Watchdog Window**

The Windowed Watchdog Timer has an optional Windowed mode that is controlled by the WDTWCS Configuration bits and [WINDOW](#) bits. In the Windowed mode, the [CLRWDT](#) instruction must occur within

the allowed window of the WDT period. Any CLRWDT instruction that occurs outside of this window will trigger a window violation and will cause a WWDT Reset, similar to a WWDT time out. See [Figure 12-2](#) for an example.

The window size is controlled by the WINDOW Configuration bits, or the WINDOW bits, if WDTWWS = 111.

The five Most Significant bits of the WDTTMR register are used to determine whether the window is open, as defined by the WINDOW bits.

In the event of a window violation, a Reset will be generated and the  $\overline{\text{WDTWW}}$  bit of the PCON0 register will be cleared. This bit is set by a POR or can be set in firmware.

**Related Links**

[8.15.2 PCON0](#)

## 12.5 Clearing the WWDT

The WWDT is cleared when any of the following conditions occur:

- Any Reset
- Valid CLRWDT instruction is executed
- Device enters Sleep
- Exit Sleep by Interrupt
- WWDT is disabled
- Oscillator Start-up Timer (OST) is running
- Any write to the WDTCON0 or [12.8.2 WDTCON1](#) registers

### 12.5.1 CLRWDT Considerations (Windowed Mode)

When in Windowed mode, the WWDT must be armed before a CLRWDT instruction will clear the timer. This is performed by reading the WDTCON0 register. Executing a CLRWDT instruction without performing such an arming action will trigger a window violation regardless of whether the window is open or not.

See [Table 12-2](#) for more information.

## 12.6 Operation During Sleep

When the device enters Sleep, the WWDT is cleared. If the WWDT is enabled during Sleep, the WWDT resumes counting. When the device exits Sleep, the WWDT is cleared again.

The WWDT remains clear until the Oscillator Start-up Timer (OST) completes, if enabled.

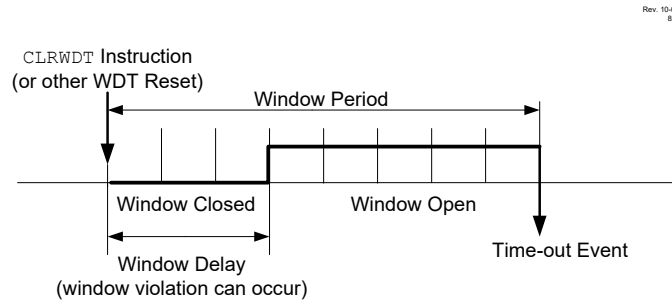
When a WWDT time-out occurs while the device is in Sleep, no Reset is generated. Instead, the device wakes up and resumes operation. The  $\overline{\text{TO}}$  and  $\overline{\text{PD}}$  bits in the STATUS register are changed to indicate the event. The  $\overline{\text{RWDT}}$  bit in the PCON0 register can also be used.

**Table 12-2. WWDT Clearing Conditions**

Conditions	WWDT
WDTE = 00	Cleared
WDTE = 01 and SEN = 0	

Conditions	WWDT
WDTE = 10 and enter Sleep	
CLRWDT Command	
Oscillator Fail Detected	
Exit Sleep + System Clock = SOSC, EXTRC, INTOSC, EXTCLK	
Exit Sleep + System Clock = XT, HS, LP	Cleared until the end of OST
Change INTOSC divider (IRCF bits)	Unaffected

**Figure 12-2. Window Period and Delay**



**Related Links**

- [9.2.1.3 Oscillator Start-up Timer \(OST\)](#)
- [7.8.4 STATUS](#)
- [8.15.2 PCON0](#)
- [7. Memory Organization](#)

## 12.7 Register Summary - WDT Control

Address	Name	Bit Pos.							
0x080C	WDTCO0	7:0			WDTPS[4:0]				SEN
0x080D	WDTCO1	7:0		WDTCS[2:0]			WINDOW[2:0]		
0x080E	WDTPSL	7:0	PSCNTL[7:0]						
0x080F	WDTPSH	7:0	PSCNTH[7:0]						
0x0810	WDTTMR	7:0	WDTTMR[4:0]				STATE	PSCNT[1:0]	

## 12.8 Register Definitions: Windowed Watchdog Timer Control

**12.8.1 WDTCON0**

**Name:** WDTCON0  
**Address:** 0x80C

Watchdog Timer Control Register 0

	Bit	7	6	5	4	3	2	1	0	
		WDTPS[4:0]							SEN	
Access				R/W	R/W	R/W	R/W	R/W	R/W	
Reset				q	q	q	q	q	0	

**Bits 5:1 – WDTPS[4:0]** Watchdog Timer Prescale Select bits<sup>(1)</sup>  
Bit Value = Prescale Rate

Value	Description
11111	Reserved. Results in minimum interval (1 ms)
to	
10011	
10010	1:8388608 (2 <sup>23</sup> ) (Interval 256s nominal)
10001	1:4194304 (2 <sup>22</sup> ) (Interval 128s nominal)
10000	1:2097152 (2 <sup>21</sup> ) (Interval 64s nominal)
01111	1:1048576 (2 <sup>20</sup> ) (Interval 32s nominal)
01110	1:524288 (2 <sup>19</sup> ) (Interval 16s nominal)
01101	1:262144 (2 <sup>18</sup> ) (Interval 8s nominal)
01100	1:131072 (2 <sup>17</sup> ) (Interval 4s nominal)
01011	1:65536 (Interval 2s nominal) (Reset value)
01010	1:32768 (Interval 1s nominal)
01001	1:16384 (Interval 512 ms nominal)
01000	1:8192 (Interval 256 ms nominal)
00111	1:4096 (Interval 128 ms nominal)
00110	1:2048 (Interval 64 ms nominal)
00101	1:1024 (Interval 32 ms nominal)
00100	1:512 (Interval 16 ms nominal)
00011	1:256 (Interval 8 ms nominal)
00010	1:128 (Interval 4 ms nominal)
00001	1:64 (Interval 2 ms nominal)
00000	1:32 (Interval 1 ms nominal)

**Bit 0 – SEN** Software Enable/Disable for Watchdog Timer bit

Value	Condition	Description
–	If WDTE = 1x	This bit is ignored
1	If WDTE = 01	WDT is turned on
0	If WDTE = 01	WDT is turned off
–	If WDTE = 00	This bit is ignored

**Note:**

- Times are approximate. WDT time is based on 31 kHz LFINTOSC.



# PIC16(L)F18455/56

## (WWDT) Windowed Watchdog Timer

---

---

2. When WDTCP3 in CONFIG3 = 11111, the Reset value (q) of WDTPS is '01011'. Otherwise, the Reset value of WDTPS is equal to WDTCP3 in CONFIG3.
3. When WDTCP3 in CONFIG3L  $\neq$  11111, these bits are read-only.

**12.8.2 WDTCON1**

**Name:** WDTCON1  
**Address:** 0x80D

Watchdog Timer Control Register 1

Bit	7	6	5	4	3	2	1	0
	WDTCS[2:0]				WINDOW[2:0]			
Access		R/W	R/W	R/W		R/W	R/W	R/W
Reset		q	q	q		q	q	q

**Bits 6:4 – WDTCS[2:0]** Watchdog Timer Clock Select bits

Value	Description
111 to 010	Reserved
001	MFINTOSC 31.25 kHz
000	LFINTOSC 31 kHz

**Bits 2:0 – WINDOW[2:0]** Watchdog Timer Window Select bits

WINDOW	Window delay Percent of time	Window opening Percent of time
111	N/A	100
110	12.5	87.5
101	25	75
100	37.5	62.5
011	50	50
010	62.5	37.5
001	75	25
000	87.5	12.5

**Note:**

1. If WDTCCS in CONFIG3 = 111, the Reset value of WDTCS is '000'.
2. The Reset value (q) of WINDOW is determined by the value of WDTCCS in the CONFIG3 register.
3. If WDTCCS in CONFIG3 ≠ 111, these bits are read-only.
4. If WDTCCS in CONFIG3 ≠ 111, these bits are read-only.

**12.8.3 WDTPSH**

**Name:** WDTPSH  
**Address:** 0x80F

WWDT Prescale Select High Register (Read-Only)

Bit	7	6	5	4	3	2	1	0
	PSCNTH[7:0]							
Access	RO	RO	RO	RO	RO	RO	RO	RO
Reset	0	0	0	0	0	0	0	0

**Bits 7:0 – PSCNTH[7:0]** Prescale Select High Byte bits<sup>(1)</sup>

**Note:**

1. The 18-bit WDT prescale value, PSCNT<17:0> includes the WDTPSL, WDTPSH and the lower bits of the WDTTMR registers. PSCNT<17:0> is intended for debug operations and should be read during normal operation.

**12.8.4 WDTPSL**

**Name:** WDTPSL  
**Address:** 0x80E

WWDT Prescale Select Low Register (Read-Only)

Bit	7	6	5	4	3	2	1	0
	PSCNTL[7:0]							
Access	RO	RO	RO	RO	RO	RO	RO	RO
Reset	0	0	0	0	0	0	0	0

**Bits 7:0 – PSCNTL[7:0]** Prescale Select Low Byte bits<sup>(1)</sup>

**Note:**

1. The 18-bit WDT prescale value, PSCNT<17:0> includes the WDTPSL, WDTPSH and the lower bits of the WDTTMR registers. PSCNT<17:0> is intended for debug operations and should be read during normal operation.

**12.8.5 WDTTMR**

**Name:** WDTTMR  
**Address:** 0x810

WDT Timer Register (Read-Only)

Bit	7	6	5	4	3	2	1	0
	WDTTMR[4:0]					STATE	PSCNT[1:0]	
Access	RO	RO	RO	RO	RO	RO	RO	RO
Reset	0	0	0	0	0	0	0	0

**Bits 7:3 – WDTTMR[4:0]** Watchdog Window Value bits

WINDOW	WDT Window State		Open Percent
	Closed	Open	
111	<b>N/A</b>	00000-11111	100
110	00000-00011	00100-11111	87.5
101	00000-00111	01000-11111	75
100	00000-01011	01100-11111	62.5
011	00000-01111	10000-11111	50
010	00000-10011	10100-11111	37.5
001	00000-10111	11000-11111	25
000	00000-11011	11100-11111	12.5

**Bit 2 – STATE** WDT Armed Status bit

Value	Description
1	WDT is armed
0	WDT is not armed

**Bits 1:0 – PSCNT[1:0]** Prescale Select Upper Byte bits<sup>(1)</sup>

**Note:**

- The 18-bit WDT prescale value, PSCNT<17:0> includes the WDTPSL, WDTPSH and the lower bits of the WDTTMR registers. PSCNT<17:0> is intended for debug operations and should be read during normal operation.

## 13. (NVM) Nonvolatile Memory Control

Nonvolatile Memory (NVM) is separated into two types: Program Flash Memory (PFM) and Data EEPROM Memory.

NVM is accessible by using both the FSR and INDF registers, or through the NVMREG register interface.

The write time is controlled by an on-chip timer. The write/erase voltages are generated by an on-chip charge pump rated to operate over the operating voltage range of the device.

NVM can be protected in two ways, by either code protection or write protection.

Code protection ( $\overline{CP}$  and  $\overline{CPD}$  bits in the Configuration Words) disables access, reading and writing to both PFM and Data EEPROM Memory via external device programmers. Code protection does not affect the self-write and erase functionality. Code protection can only be reset by a device programmer performing a Bulk Erase to the device, clearing all nonvolatile memory, Configuration bits and User IDs.

Write protection prohibits self-write and erase to a portion or all of the NVM, as defined by the  $\overline{WRTSAF}$ ,  $\overline{WRTD}$ ,  $\overline{WRTC}$ ,  $\overline{WRTB}$ , and  $\overline{WRTAPP}$  bits of Configuration Word 4. Write protection does not affect a device programmer's ability to read, write, or erase the device.

### Related Links

[4.7.4 CONFIG4](#)

[4.7.5 CONFIG5](#)

### 13.1 Program Flash Memory

Program Flash memory consists of an array of 14-bit words as user memory, with additional words for user ID information, Configuration words, and interrupt vectors. Program memory provides storage locations for:

- User program instructions
- User defined data

Program memory data can be read and/or written to through:

- CPU instruction fetch (read-only)
- FSR/INDF indirect access (read-only)
- NVMREG access
- In-Circuit Serial Programming™ (ICSP™)

Read operations return a single word of memory. When write and erase operations are done on a row basis, the row size is defined. Program memory will erase to a logic '1' and program to a logic '0'.

It is important to understand the program memory structure for erase and programming operations. Program memory is arranged in rows. A row consists of 32 14-bit program memory words. A row is the minimum size that can be erased by user software.

All or a portion of a row can be programmed. Data to be written into the program memory row is written to 14-bit wide data write latches. These latches are not directly accessible, but may be loaded via sequential writes to the NVMDATH:NVMDATL register pair.



**Important:** To modify only a portion of a previously programmed row, the contents of the entire row must be read. Then, the new data and retained data can be written into the write latches to reprogram the row of program memory. However, any unprogrammed locations can be written without first erasing the row. In this case, it is not necessary to save and rewrite the other previously programmed locations.

---

#### Related Links

[13.3 FSR and INDF Access](#)

[13.4 NVMREG Access](#)

### 13.1.1 Program Memory Voltages

The program memory is readable and writable during normal operation over the full  $V_{DD}$  range.

#### 13.1.1.1 Programming Externally

The program memory cell and control logic support write and Bulk Erase operations down to the minimum device operating voltage. Special BOR operation is enabled during Bulk Erase.

#### Related Links

[8.2.4 BOR is Always OFF](#)

#### 13.1.1.2 Self-programming

The program memory cell and control logic will support write and row erase operations across the entire  $V_{DD}$  range. Bulk Erase is not available when self-programming.

## 13.2 Data EEPROM

Data EEPROM consists of 256 bytes of user data memory. The EEPROM provides storage locations for 8-bit user defined data.

EEPROM can be read and/or written through:

- FSR/INDF indirect access
- NVMREG access
- External device programmer

Unlike Program Flash Memory, which must be written to by row, EEPROM can be written to byte by byte.

#### Related Links

[13.3 FSR and INDF Access](#)

[13.4 NVMREG Access](#)

## 13.3 FSR and INDF Access

The FSR and INDF registers allow indirect access to the program memory or EEPROM.

#### Related Links

[7.8.5 FSR0](#)

### 13.3.1 FSR Read

With the intended address loaded into an FSR register a `MOVIW` instruction or read of `INDF` will read data from the program memory or EEPROM.

Reading from NVM requires one instruction cycle. The CPU operation is suspended during the read, and resumes immediately after. Read operations return a single byte of memory.

### 13.3.2 FSR Write

Writing/erasing the NVM through the FSR registers (ex. `MOVWI` instruction) is not supported in the PIC16(L)F184XX devices.

## 13.4 NVMREG Access

The NVMREG interface allows read/write access to all the locations accessible by FSRs, and also read/write access to the User ID locations and EEPROM, and read-only access to the device identification, revision, and configuration data.

Writing or erasing of NVM via the NVMREG interface is prevented when the device is write-protected.

### 13.4.1 NVMREG Read Operation

To read a NVM location using the NVMREG interface, the user must:

1. Clear the `NVMREGS` bit of the `NVMCON1` register if the user intends to access program memory locations, or set `NMVREGS` if the user intends to access User ID, EEPROM, or configuration locations.
2. Write the desired address into the `NVMADRH:NVMADRL` register pair.
3. Set the `RD` bit of the `NVMCON1` register to initiate the read.

Once the read control bit is set, the CPU operation is suspended during the read, and resumes immediately after. The data is available in the very next cycle, in the `NVMDATH:NVMDATL` register pair; therefore, it can be read as two bytes in the following instructions.

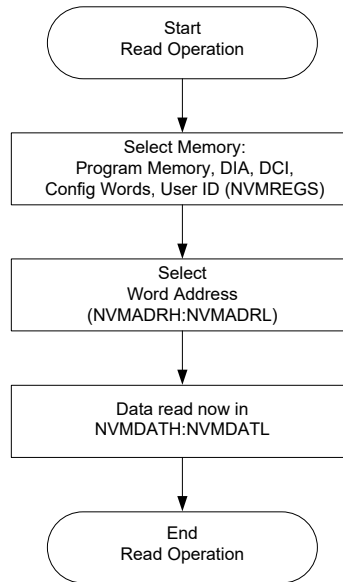
`NVMDATH:NVMDATL` register pair will hold this value until another read or until it is written to by the user.

Upon completion, the `RD` bit is cleared by hardware.



**Figure 13-1. Flash Program Memory Read Flowchart**

Rev. 10-000046E  
5/17/2017



**Example 13-1. Program Memory read**

```

* This code block will read 1 word of program
* memory at the memory address:
  PROG_ADDR_HI : PROG_ADDR_LO
* data will be returned in the variables;
* PROG_DATA_HI, PROG_DATA_LO

      BANKSEL      NVMADRL          ; Select Bank for NVMCON registers
      MOVLW        PROG_ADDR_LO    ;
      MOVWF        NVMADRL          ; Store LSB of address
      MOVLW        PROG_ADDR_HI    ;
      MOVWF        NVMADRH          ; Store MSB of address

      BCF          NVMCON1,NVMREGS ; Do not select Configuration Space
      BSF          NVMCON1,RD       ; Initiate read

      MOVF         NVMDATL,W        ; Get LSB of word
      MOVWF        PROG_DATA_LO    ; Store in user location
      MOVF         NVMDATH,W        ; Get MSB of word
      MOVWF        PROG_DATA_HI    ; Store in user location
  
```

**Related Links**

- [13.6.1 NVMDR](#)
- [13.6.2 NVMDAT](#)
- [13.6.3 NVMCON1](#)

**13.4.2 NVM Unlock Sequence**

The unlock sequence is a mechanism that protects the NVM from unintended self-write programming or erasing. The sequence must be executed and completed without interruption to successfully complete any of the following operations:

- Program Flash Memory Row Erase
- Load of Program Flash Memory write latches

- Write of Program Flash Memory write latches to program memory
- Write of Program Flash Memory write latches to User IDs
- Write to EEPROM

The unlock sequence consists of the following steps and must be completed in order:

- Write 55h to NVMCON2
- Write AAh to NVMCON2
- Set the WR bit of NVMCON1

Once the WR bit is set, the processor will stall internal operations until the operation is complete and then resume with the next instruction.

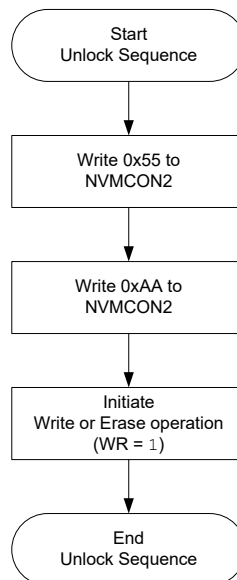


**Important:** The two NOP instructions after setting the WR bit that were required in previous devices are not required for PIC16(L)F184XX devices. See figure below.

Since the unlock sequence must not be interrupted, global interrupts should be disabled prior to the unlock sequence and re-enabled after the unlock sequence is completed.

**Figure 13-2. NVM Unlock Sequence Flowchart**

Rev. 10-00047B  
8/24/2015



### Example 13-2. NVM Unlock Sequence

```

BCF      INTCON, GIE      ; Recommended so sequence is not interrupted
BANKSEL  NVMCON1         ;
BSF      NVMCON1, WREN   ; Enable write/erase
MOVLW   55h              ; Load 55h
MOVWF   NVMCON2         ; Step 1: Load 55h into NVMCON2
MOVLW   AAh              ; Step 2: Load W with AAh
MOVWF   NVMCON2         ; Step 3: Load AAH into NVMCON2
  
```

BSF	NVMCON1, WR	; Step 4: Set WR bit to begin write/erase
BSF	INTCON, GIE	; Re-enable interrupts

**Note:**

1. Sequence begins when NVMCON2 is written; steps 1-4 must occur in the cycle-accurate order shown.
2. Opcodes shown are illustrative; any instruction that has the indicated effect may be used.

### 13.4.3 NVMREG Write to EEPROM

Writing to the EEPROM is accomplished by the following steps:

1. Set the NVMREGS and WREN bits of the NVMCON1 register.
2. Write the desired address (address +7000h) into the NVMADRH:NVMADRL register pair.
3. Perform the unlock sequence as described in the “*NVM Unlock Sequence*” section.

A single EEPROM byte is written with NVMDATA. The operation includes an implicit erase cycle for that byte (it is not necessary to set the FREE bit), and requires many instruction cycles to finish. CPU execution continues in parallel and, when complete, WR is cleared by hardware, NVMIF is set, and an interrupt will occur if NVMIE is also set. Software must poll the WR bit to determine when writing is complete, or wait for the interrupt to occur. WREN will remain unchanged. Once the EEPROM write operation begins, clearing the WR bit will have no effect; the operation will run to completion.

**Related Links**

[13.4.2 NVM Unlock Sequence](#)

[13.4.4 NVMREG Erase of Program Memory](#)

### 13.4.4 NVMREG Erase of Program Memory

Before writing to program memory, the word(s) to be written must be erased or previously unwritten. Program memory can only be erased one row at a time. No automatic erase occurs upon the initiation of the write to program memory. To erase a program memory row:

1. Clear the NVMREGS bit of the NVMCON1 register to erase program memory locations, or set the NVMREGS bit to erase User ID locations.
2. Write the desired address into the NVMADRH:NVMADRL register pair.
3. Set the FREE and WREN bits of the NVMCON1 register.
4. Perform the unlock sequence as described in the “*NVM Unlock Sequence*” section.

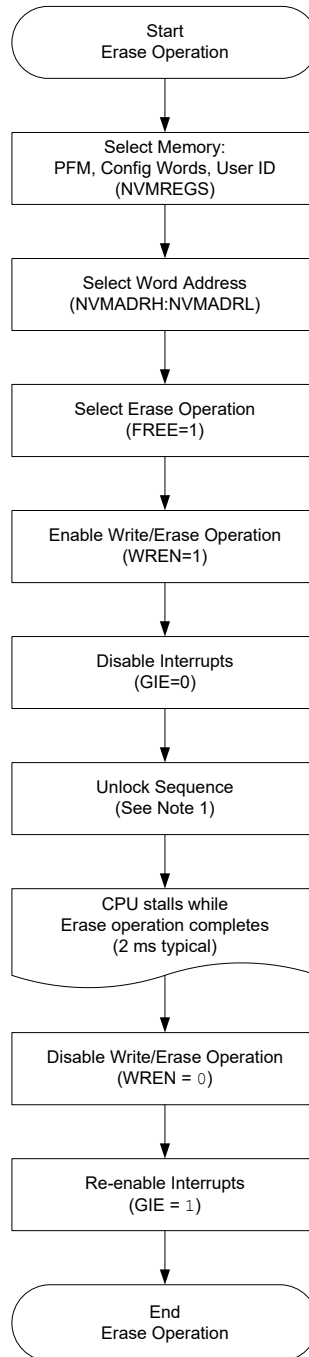
If the program memory address is write-protected, the WR bit will be cleared and the erase operation will not take place.

While erasing program memory, CPU operation is suspended, and resumes when the operation is complete. Upon completion, the NVMIF is set, and an interrupt will occur if the NVMIE bit is also set.

Write latch data is not affected by erase operations, and WREN will remain unchanged.

Figure 13-3. NVM Erase Flowchart

Rev. 10-000048B  
03/24/2015



**Note:** See previous figure.

**Example 13-3. Erasing One Row of Program Flash Memory**

```

; This sample row erase routine assumes the following:
; 1.A valid address within the erase row is loaded in variables ADDRH:ADDRL
; 2.ADDRH and ADDRL are located in common RAM (locations 0x70 - 0x7F)
    
```

# PIC16(L)F18455/56

## (NVM) Nonvolatile Memory Control

```

BANKSEL    NVMADRL
MOVWF     ADDR_L,W
MOVWF     NVMADRL           ; Load lower 8 bits of erase address boundary
MOVWF     ADDR_H,W
MOVWF     NVMADRH           ; Load upper 6 bits of erase address boundary
BCF       NVMCON1,NVMREGS   ; Choose PFM memory area
BSF       NVMCON1,FREE      ; Specify an erase operation
BSF       NVMCON1,WREN      ; Enable writes
BCF       INTCON,GIE        ; Disable interrupts during unlock sequence

; -----REQUIRED UNLOCK SEQUENCE:-----

MOVLW     55h               ; Load 55h to get ready for unlock sequence
MOVWF     NVMCON2           ; First step is to load 55h into NVMCON2
MOVLW     AAh               ; Second step is to load AAh into W
MOVWF     NVMCON2           ; Third step is to load AAh into NVMCON2
BSF       NVMCON1,WR        ; Final step is to set WR bit

; -----

BSF       INTCON,GIE        ; Re-enable interrupts, erase is complete
BCF       NVMCON1,WREN      ; Disable writes

```

**Table 13-1. NVM Organization and Access Information**

Master Values				NVMREG Access			FSR Access	
Memory Function	Memory Type	Program Counter (PC)	ICSP Address	NVMREGS bit (NVMCON1)	NVMADR<14:0>	Allowed Operations	FSR Address	FSR Programming Access
RESET VECTOR	Program Flash Memory	0000h	0000h	0	0000h	READ/ WRITE	8000h	READ ONLY
USER MEMORY		0001h	0001h	0	0001h		8001h	
		0003h	0003h		0003h		8003h	
INT VECTOR		0004h	0004h	0	0004h		8004h	
USER MEMORY		0005h	0005h	0	0005h		8005h	
		7FFFh <sup>(1)</sup>	7FFFh <sup>(1)</sup>		7FFFh <sup>(1)</sup>		FFFFh	
USER ID	Program Flash Memory	NO PC ACCESS	8000h	1	0000h	READ	NO ACCESS	
			8003h		0003h			
Reserved	—		—	—	0004h	—		
REV ID	HC		8005h	1	0005h	READ		
DEVICE ID			8006h	1	0006h			
CONFIG1	FUSE		8007h	1	0007h	READ/ WRITE		
CONFIG2			8008h	1	0008h			
CONFIG3			8009h	1	0009h			
CONFIG4			800Ah	1	000Ah			
CONFIG5			800Bh	1	000Bh			
DIA and DCI	PFM	8100h	1	0100h	READ			
		82FFh	1	02FFh				
USER MEMORY	EEPROM	F000h	1	7000h	READ/ WRITE	7000h	READ ONLY	
		F0FFh		70FFh		70FFh		

**Note:**

1. 7FFFh is the maximum Program Flash Memory address for the PIC16(L)F184XX family.

**Related Links**

[7. Memory Organization](#)

### 13.4.5 NVMREG Write to Program Memory

Program memory is programmed using the following steps:

1. Load the address of the row to be programmed into NVMADRH:NVMADRL.
2. Load each write latch with data.
3. Initiate a programming operation.
4. Repeat steps 1 through 3 until all data is written.

Before writing to program memory, the word(s) to be written must be erased or previously unwritten. Program memory can only be erased one row at a time. No automatic erase occurs upon the initiation of the write.

Program memory can be written one or more words at a time. The maximum number of words written at one time is equal to the number of write latches. See the figure below (row writes to program memory with 32 write latches) for more details.

The write latches are aligned to the Flash row address boundary defined by the upper ten bits of NVMADRH:NVMADRL, (NVMADRH<6:0>:NVMADRL<7:5>) with the lower five bits of NVMADRL, (NVMADRL<4:0>) determining the write latch being loaded. Write operations do not cross these boundaries. At the completion of a program memory write operation, the data in the write latches is reset to contain 0x7FFF.

The following steps should be completed to load the write latches and program a row of program memory. These steps are divided into two parts. First, each write latch is loaded with data from the NVMDATH:NVMDATL using the unlock sequence with LWLO = 1. When the last word to be loaded into the write latch is ready, the LWLO bit is cleared and the unlock sequence executed. This initiates the programming operation, writing all the latches into Flash program memory.



**Important:** The special unlock sequence is required to load a write latch with data or initiate a Flash programming operation. If the unlock sequence is interrupted, writing to the latches or program memory will not be initiated.

1. Set the WREN bit of the NVMCON1 register.
2. Clear the NVMREGS bit of the NVMCON1 register.
3. Set the LWLO bit of the NVMCON1 register. When the LWLO bit of the NVMCON1 register is '1', the write sequence will only load the write latches and will not initiate the write to Flash program memory.
4. Load the NVMADRH:NVMADRL register pair with the address of the location to be written.
5. Load the NVMDATH:NVMDATL register pair with the program memory data to be written.
6. Execute the unlock sequence. The write latch is now loaded.
7. Increment the NVMADRH:NVMADRL register pair to point to the next location.
8. Repeat steps 5 through 7 until all but the last write latch has been loaded.

9. Clear the LWLO bit of the NVMCON1 register. When the LWLO bit of the NVMCON1 register is '0', the write sequence will initiate the write to Flash program memory.
10. Load the NVMDATH:NVMDATL register pair with the program memory data to be written.
11. Execute the unlock sequence. The entire program memory latch content is now written to Flash program memory.



**Important:** The program memory write latches are reset to the blank state (0x7FFF) at the completion of every write or erase operation. As a result, it is not necessary to load all the program memory write latches. Unloaded latches will remain in the blank state.

An example of the complete write sequence is shown in [Writing to Program Flash Memory](#). The initial address is loaded into the NVMADRH:NVMDATL register pair; the data is loaded using indirect addressing.

**Figure 13-4. NVMREG Writes to Program Flash Memory With 32 Write Latches**

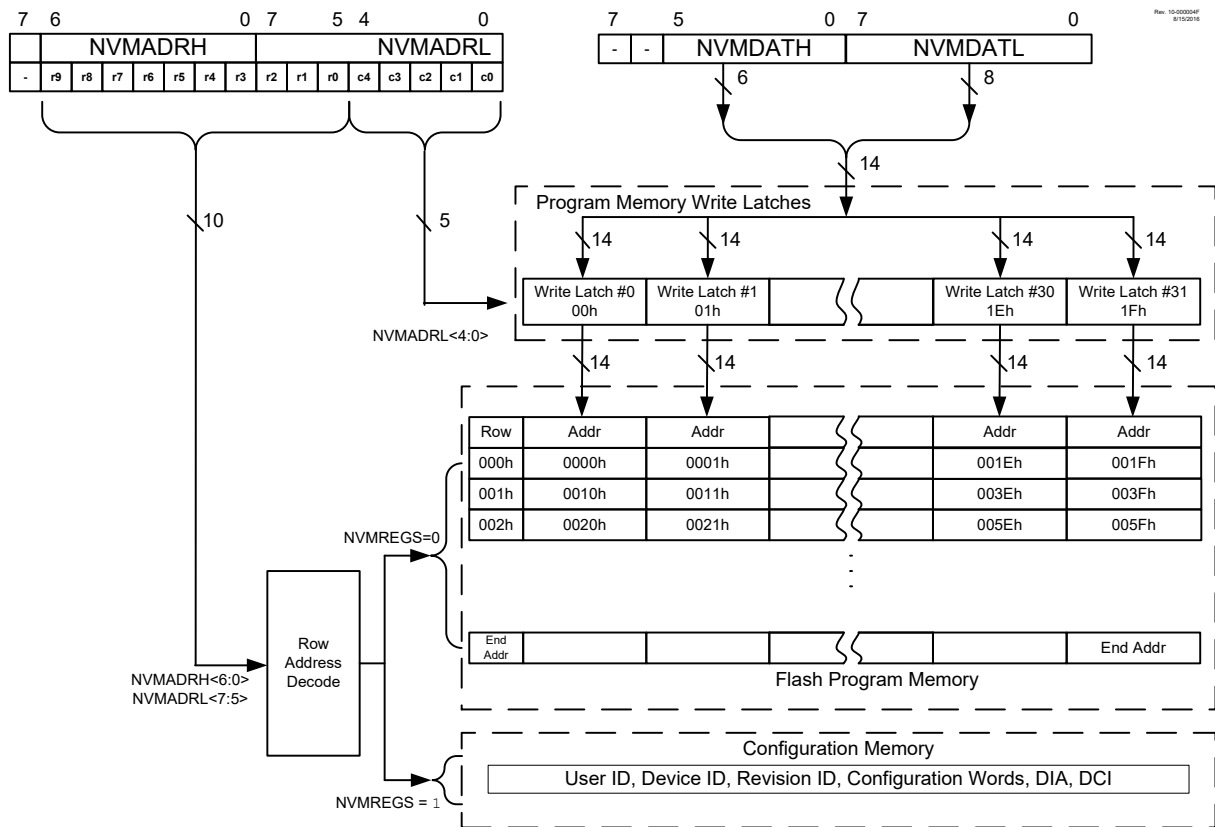
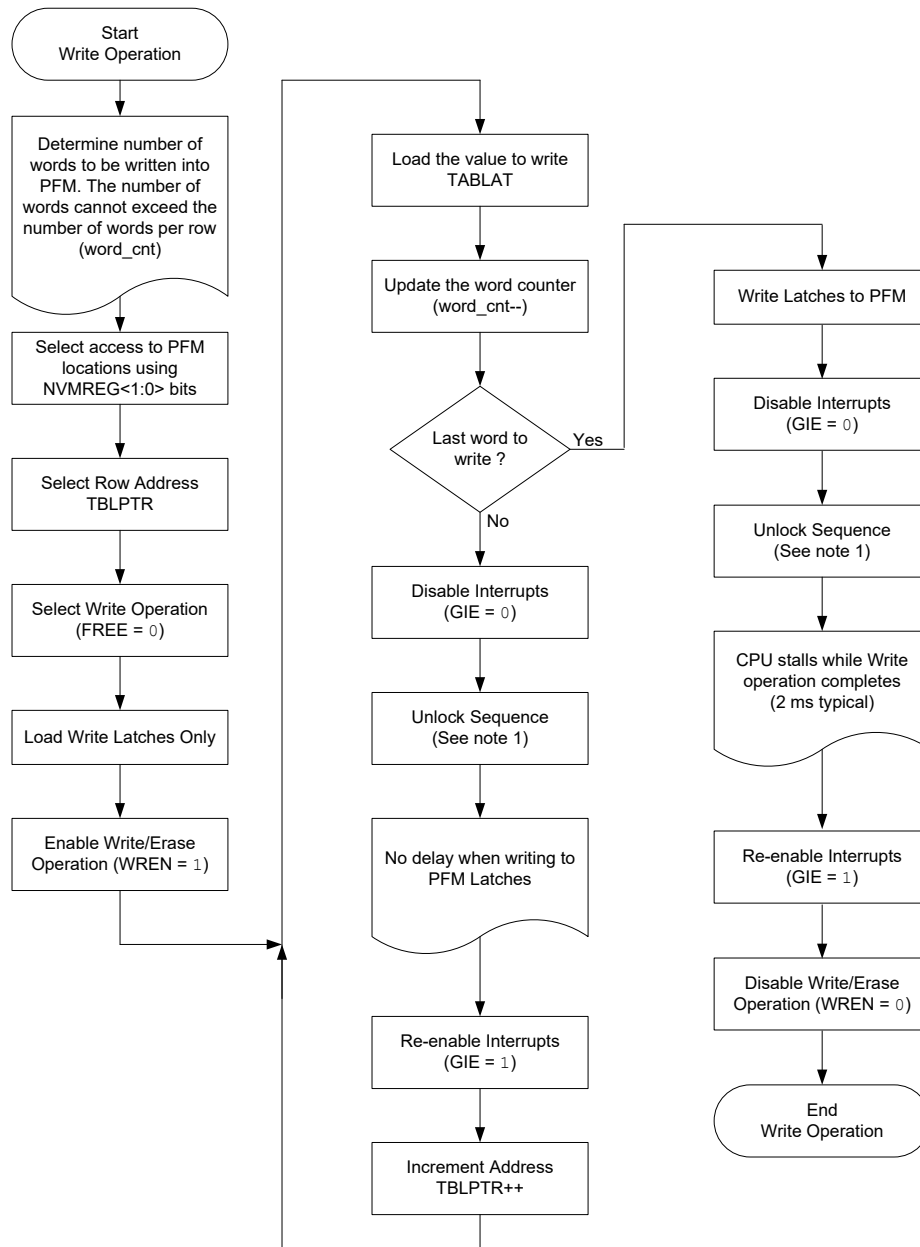


Figure 13-5. Program Flash Memory Flowchart

Rev. 10-000049C  
04/2015



**Note:**

1. See [NVM Unlock Sequence Flowchart](#)

**Example 13-4. Writing to Program Flash Memory**

```

; This write routine assumes the following:
; 1. 64 bytes of data are loaded, starting at the address in DATA_ADDR
; 2. Each word of data to be written is made up of two adjacent bytes in
DATA_ADDR,
; stored in little endian format
; 3. A valid starting address (the least significant bits = 00000) is
  
```



```

loaded in ADDRH:ADDRL
; 4. ADDRH and ADDRL are located in common RAM (locations 0x70 - 0x7F)
; 5. NVM interrupts are not taken into account

BANKSEL    NVMADRH
MOV        ADDRH,W
MOVWF     NVMADRH           ; Load initial address
MOV        ADDRL,W
MOVWF     NVMADRL
MOVLW    LOW DATA_ADDR    ; Load initial data address
MOVWF     FSR0L
MOVLW    HIGH DATA_ADDR
MOVWF     FSR0H
BCF       NVMCON1,NVMREGS  ; Set Program Flash Memory as write location
BSF       NVMCON1,WREN     ; Enable writes
BSF       NVMCON1,LWLO    ; Load only write latches

LOOP

    MOVIW   FSR0++
    MOVWF   NVMDATL        ; Load first data byte
    MOVIW   FSR0++
    MOVWF   NVMDATH        ; Load second data byte

    MOVF    NVMADRL,W
    XORLW  0x1F
    ANDLW  0x1F            ; Check if lower bits of address are 00000
                                ; and if on last of 32 addresses
    BTFSC  STATUS,Z       ; Last of 32 words?
    GOTO   START_WRITE    ; If so, go write latches into memory

    CALL   UNLOCK_SEQ     ; If not, go load latch
    INCF   NVMADRL,F      ; Increment address
    GOTO   LOOP

START_WRITE

    BCF    NVMCON1,LWLO   ; Latch writes complete, now write memory
    CALL   UNLOCK_SEQ     ; Perform required unlock sequence
    BCF    NVMCON1,WREN   ; Disable writes

UNLOCK_SEQ

    MOVLW  55h
    BCF    INTCON,GIE     ; Disable interrupts
    MOVWF  NVMCON2        ; Begin unlock sequence
    MOVLW  AAh
    MOVWF  NVMCON2
    BSF    NVMCON1,WR
    BSF    INTCON,GIE     ; Unlock sequence complete, re-enable
interrupts
return

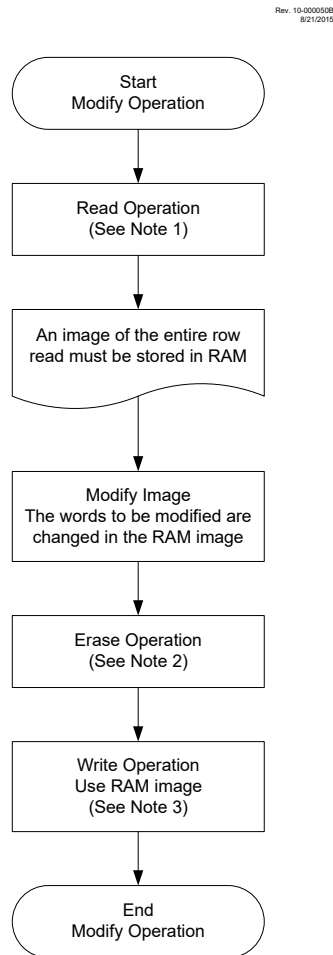
```

### 13.4.6 Modifying Flash Program Memory

When modifying existing data in a program memory row, and data within that row must be preserved, it must first be read and saved in a RAM image. Program memory is modified using the following steps:

1. Load the starting address of the row to be modified.
2. Read the existing data from the row into a RAM image.
3. Modify the RAM image to contain the new data to be written into program memory.
4. Load the starting address of the row to be rewritten.
5. Erase the program memory row.
6. Load the write latches with data from the RAM image.
7. Initiate a programming operation.

Figure 13-6. Flash Program Memory Modify Flowchart



**Note:**

1. See [Flash Program Memory Read Flowchart](#).
2. See [NVM Erase Flowchart](#).
3. See [Program Flash Memory Flowchart](#).

**13.4.7 NVMREG Access to Device Information Area, Device Configuration Area, User ID, Device ID, EEPROM, and Configuration Words**

NVMREGS can be used to access the following memory regions:

- Device Information Area (DIA)
- Device Configuration Information (DCI)
- User ID region
- Device ID and Revision ID
- Configuration Words
- EEPROM

The value of NVMREGS is set to '1' in the NVMCON1 register to access these regions. The memory regions listed above would be pointed to by PC<15> = 1, but not all addresses reference valid data. Different access may exist for reads and writes. Refer to the table below. When read access is initiated on

an address outside the parameters listed in the following table, the NVMDATH: NVMDATL register pair is cleared, reading back '0's.

**Table 13-2. NVMREG Access to Device Information Area, Device Configuration Area, User ID, Device ID, EEPROM, and Configuration Words (NVMREGS = 1)**

Address	Function	Read Access	Write Access
8000h-8003h	User IDs	Yes	Yes
8005h-8006h	Device ID/Revision ID	Yes	No
8007h-800Bh	Configuration Words 1-5	Yes	Yes
8100h-82FFh	DIA and DCI	Yes	No
F000h-F0FFh	EEPROM	Yes	Yes

**Example 13-5. Device ID Access**

```

; This write routine assumes the following:
; 1. A full row of data are loaded, starting at the address in DATA_ADDR
; 2. Each word of data to be written is made up of two adjacent bytes in
DATA_ADDR,
; stored in little endian format
; 3. A valid starting address (the least significant bits = 00000) is
loaded in ADDRH:ADDRL
; 4. ADDRH and ADDRL are located in common RAM (locations 0x70 - 0x7F)
; 5. NVM interrupts are not taken into account

BANKSEL    NVMADRH
MOVWF     ADDRH,W
MOVWF     NVMADRH           ; Load initial address
MOVWF     ADDRL,W
MOVWF     NVMADRL
MOVLW    LOW DATA_ADDR   ; Load initial data address
MOVWF     FSR0L
MOVLW    HIGH DATA_ADDR
MOVWF     FSR0H
BCF      NVMCON1,NVMREGS  ; Set PFM as write location
BSF      NVMCON1,WREN     ; Enable writes
BSF      NVMCON1,LWLO    ; Load only write latches

LOOP

    MOVIW   FSR0++
    MOVWF  NVMDATL           ; Load first data byte
    MOVIW   FSR0++
    MOVWF  NVMDATH           ; Load second data byte
    CALL   UNLOCK_SEQ       ; If not, go load latch
    INCF   NVMADRL,F        ; Increment address
    MOVF   NVMADRL,W
    XORLW  0x1F             ; Check if lower bits of address are 00000
    ANDLW  0x1F             ; and if on last of 32 addresses
    BTFSC  STATUS,Z        ; Last of 32 words?
    GOTO   START_WRITE     ; If so, go write latches into memory

    GOTO   LOOP

START_WRITE

    BCF    NVMCON1,LWLO    ; Latch writes complete, now write memory
    CALL  UNLOCK_SEQ      ; Perform required unlock sequence
    BCF    NVMCON1,LWLO    ; Disable writes

UNLOCK_SEQ

    MOVLW  55h

```

```

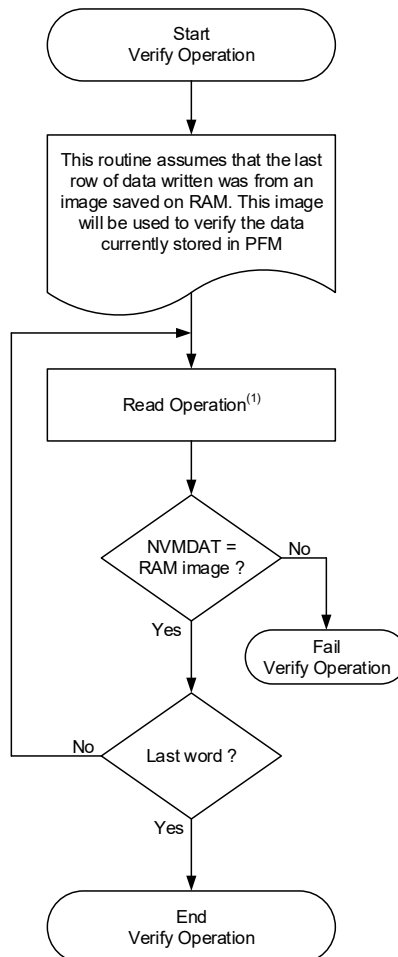
BCF      INTCON,GIE      ; Disable interrupts
MOVWF   NVMCON2         ; Begin unlock sequence
MOVLW   AAh
MOVWF   NVMCON2
BSF     NVMCON1,WR
BSF     INTCON,GIE      ; Unlock sequence complete, re-enable
interrupts
return
    
```

### 13.4.8 Write Verify

It is considered good programming practice to verify that program memory writes agree with the intended value. Since program memory is stored as a full row then the stored program memory contents are compared with the intended data stored in RAM after the last write is complete.

**Figure 13-7. Flash Program Memory Verify Flowchart**

Rev. 10-00051B  
12/4/2015



**Note:**

1. See [Flash Program Memory Read Flowchart](#).

**13.4.9 WRERR Bit**

The WRERR bit can be used to determine if a write error occurred. WRERR will be set if one of the following conditions occurs:

- If WR is set while the NVMADRH:NMVADRL points to a write-protected address
- A Reset occurs while a self-write operation was in progress
- An unlock sequence was interrupted

The WRERR bit is normally set by hardware, but can be set by the user for test purposes. Once set, WRERR must be cleared in software.

**Table 13-3. Actions for PFM When WR = 1**

Free	LWLO	Actions for PFM when WR = 1	Comments
1	x	Erase the 32-word row of NVMADRH:NMVADRL location.	<ul style="list-style-type: none"> <li>• If WP is enabled, WR is cleared and WRERR is set</li> <li>• All 32 words are erased</li> <li>• NVMDATH:NVMDATL is ignored</li> </ul>
0	1	Copy NVMDATH:NVMDATL to the write latch corresponding to NVMADR LSBs.	<ul style="list-style-type: none"> <li>• Write protection is ignored</li> <li>• No memory access occurs</li> </ul>
0	0	Write the write-latch data to PFM row.	<ul style="list-style-type: none"> <li>• If WP is enabled, WR is cleared and WRERR is set</li> <li>• Write latches are reset to 3FFh</li> <li>• NVMDATH:NVMDATL is ignored</li> </ul>

**Related Links**

[13.4.4 NVMREG Erase of Program Memory](#)

### 13.5 Register Summary: NVM Control

Address	Name	Bit Pos.									
0x081A	NVMADR	7:0	NVMADR <sub>L</sub> [7:0]								
		15:8		NVMADR <sub>H</sub> [6:0]							
0x081C	NVMDAT	7:0	NVMDAT <sub>L</sub> [7:0]								
		15:8			NVMDAT <sub>H</sub> [5:0]						
0x081E	NVMCON1	7:0		NVMREGS	LWLO	FREE	WRERR	WREN	WR	RD	
0x081F	NVMCON2	7:0	NVMCON2[7:0]								

### 13.6 Register Definitions: Nonvolatile Memory

**13.6.1 NVMADR**

**Name:** NVMADR  
**Address:** 0x81A

Nonvolatile Memory Address Register

Bit	15	14	13	12	11	10	9	8
	NVMADRH[6:0]							
Access	R/W	R/W	R/W	R/W	R/W	R/W	R/W	R/W
Reset	1	0	0	0	0	0	0	0
Bit	7	6	5	4	3	2	1	0
	NVMADRL[7:0]							
Access	R/W	R/W	R/W	R/W	R/W	R/W	R/W	R/W
Reset	0	0	0	0	0	0	0	0

**Bits 14:8 – NVMADRH[6:0]** NVM Most Significant Address bits  
 Specifies the Most Significant bits for program memory address.

**Bits 7:0 – NVMADRL[7:0]** NVM Least Significant Address bits  
 Specifies the Least Significant bits for program memory address.

**Note:**

1. Bit <15> is undefined while WR = 1

**13.6.2 NVMDAT**

**Name:** NVMDAT  
**Address:** 0x81C

Nonvolatile Memory Data Register

Bit	15	14	13	12	11	10	9	8
			NVMDATH[5:0]					
Access			R/W	R/W	R/W	R/W	R/W	R/W
Reset			x	x	x	x	x	x
Bit	7	6	5	4	3	2	1	0
	NVMDATL[7:0]							
Access	R/W	R/W	R/W	R/W	R/W	R/W	R/W	R/W
Reset	x	x	x	x	x	x	x	x

**Bits 13:8 – NVMDATH[5:0]** Read/write value for Most Significant bits of program memory  
 Reset States: POR/BOR = xxxxxx  
                   All Other Resets = uuuuuu

**Bits 7:0 – NVMDATL[7:0]** Read/write value for Least Significant bits of program memory  
 Reset States: POR/BOR = xxxxxxxx  
                   All Other Resets = uuuuuuuu



**13.6.3 NVMCON1**

**Name:** NVMCON1  
**Address:** 0x81E

Nonvolatile Memory Control 1 Register

Bit	7	6	5	4	3	2	1	0
		NVMREGS	LWLO	FREE	WRERR	WREN	WR	RD
Access		R/W	R/W	R/S/HC	R/W/HS	R/W	R/S/HC	R/S/HC
Reset		0	0	0	x	0	0	0

**Bit 6 – NVMREGS** NVM Region Selection bit

Value	Description
1	Access EEPROM, DIA, DCI, Configuration, User ID and Device ID Registers
0	Access Program Flash Memory

**Bit 5 – LWLO** Load Write Latches Only bit

Value	Condition	Description
1	When FREE = 0	The next WR command updates the write latch for this word within the row; no memory operation is initiated.
0	When FREE = 0	The next WR command writes data or erases
–	Otherwise:	This bit is ignored.

**Bit 4 – FREE** Program Flash Memory Erase Enable bit

Value	Description
1	Performs an erase operation with the next WR command; the 32-word pseudo-row containing the indicated address is erased (to all 1s) to prepare for writing.
0	The next WR command writes without erasing.

**Bit 3 – WRERR**

Write-Reset Error Flag bit<sup>(1,2,3)</sup>

Reset States: POR/BOR = x

All Other Resets = q

Value	Description
1	A write operation was interrupted by a Reset, interrupted unlock sequence, or WR was written to one while NVMADR points to a write-protected address.
0	All write operations have completed normally.

**Bit 2 – WREN** Program/Erase Enable bit

Value	Description
1	Allows program/erase cycles
0	Inhibits programming/erasing of program Flash

**Bit 1 – WR** Write Control bit<sup>(4,5,6)</sup>

# PIC16(L)F18455/56

## (NVM) Nonvolatile Memory Control

Value	Condition	Description
1	When NVMREG:NVMADR points to a Program Flash Memory location:	Initiates the operation indicated by table in “WRERR Bit” section.
0	When NVMREG:NVMADR points to a Program Flash Memory location:	NVM program/erase operation is complete and inactive.
1	When NVMREG:NVMADR points to a EEPROM location:	Initiates an erase/program cycle at the corresponding EEPROM location.
0	When NVMREG:NVMADR points to a EEPROM location:	NVM program/erase operation is complete and inactive.

### Bit 0 – RD Read Control bit<sup>(7)</sup>

Value	Description
1	Initiates a read at address = NVMADR1, and loads data to NVMDAT. Read takes one instruction cycle and the bit is cleared when the operation is complete. The bit can only be set (not cleared) in software.
0	NVM read operation is complete and inactive

#### Note:

1. Bit is undefined while WR = 1 (during the EEPROM write operation it may be ‘0’ or ‘1’).
2. Bit must be cleared by software; hardware will not clear this bit.
3. Bit may be written to ‘1’ by the user in order to implement test sequences.
4. This bit can only be set by following the sequence described in the “NVM Unlock Sequence” section.
5. Operations are self-timed and the WR bit is cleared by hardware when complete.
6. Once a write operation is initiated, setting this bit to zero will have no effect.
7. Reading from EEPROM loads only NVMDATL.

#### Related Links

[13.4.2 NVM Unlock Sequence](#)

[13.4.9 WRERR Bit](#)

**13.6.4 NVMCON2**

**Name:** NVMCON2  
**Address:** 0x81F

Nonvolatile Memory Control 2 Register

Bit	7	6	5	4	3	2	1	0
	NVMCON2[7:0]							
Access	WO	WO	WO	WO	WO	WO	WO	WO
Reset	0	0	0	0	0	0	0	0

**Bits 7:0 – NVMCON2[7:0]** Flash Memory Unlock Pattern bits

**Note:** To unlock writes, a 55h must be written first followed by an AAh before setting the WR bit of the NVMCON1 register. The value written to this register is used to unlock the writes.

## 14. I/O Ports

### 14.1 PORT Availability

Table 14-1. PORT Availability Per Device

PORTs	PORT Description	PIC16(L)F18455	PIC16(L)F18456
PORTA	8-bit wide, bidirectional port.	•	•
PORTB	8-bit wide, bidirectional port.	•	•
PORTC	8-bit wide, bidirectional port.	•	•
PORTE	1-bit wide, available only when Master Clear functionality is disabled (MCLRE = 0).	•	•

### 14.2 I/O Ports Description

Each port has standard registers for its operation. These registers are:

- PORTx registers (reads the levels on the pins of the device)
- LATx registers (output latch)
- TRISx registers (data direction)
- ANSELx registers (analog select)
- WPUx registers (weak pull-up)
- INLVLx (input level control)
- SLRCONx registers (slew rate control)
- ODCONx registers (open-drain control)

Most port pins share functions with device peripherals, both analog and digital. In general, when a peripheral is enabled on a port pin, that pin cannot be used as a general purpose output; however, the pin can still be read.

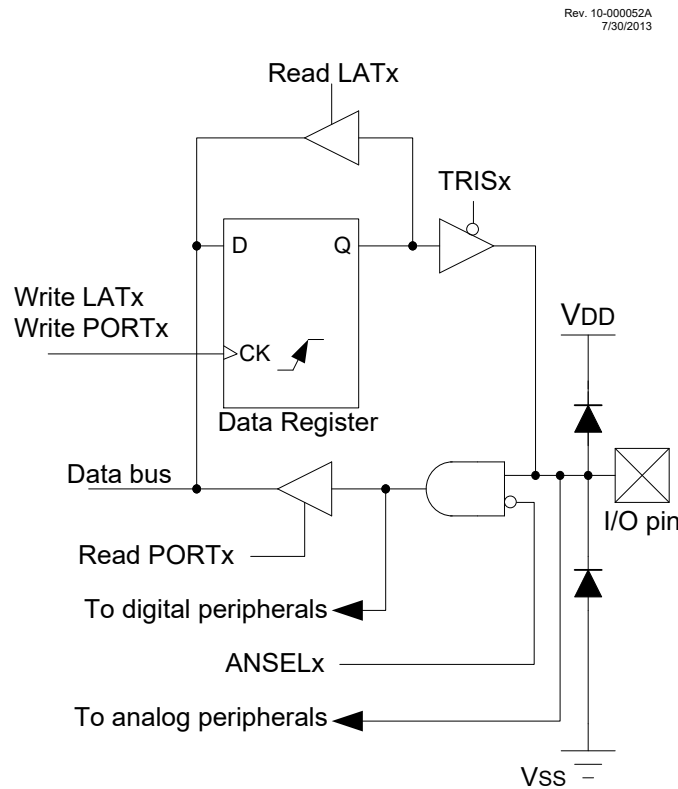
The Data Latch (LATx registers) is useful for read-modify-write operations on the value that the I/O pins are driving.

A write operation to the LATx register has the same effect as a write to the corresponding PORTx register. A read of the LATx register reads of the values held in the I/O PORT latches, while a read of the PORTx register reads the actual I/O pin value.

Ports that support analog inputs have an associated ANSELx register. When an ANSELx bit is set, the digital input buffer associated with that bit is disabled.

Disabling the input buffer prevents analog signal levels on the pin between a logic high and low from causing excessive current in the logic input circuitry. A simplified model of a generic I/O port, without the interfaces to other peripherals, is shown in the following figure:

**Figure 14-1. Generic I/O Port Operation**



### 14.3 I/O Priorities

Each pin defaults to the PORT data latch after Reset. Other functions are selected with the peripheral pin select logic. See “Peripheral Pin Select (PPS) Module” for more information.

Analog input functions, such as ADC and comparator inputs, are not shown in the peripheral pin select lists. These inputs are active when the I/O pin is set for Analog mode using the ANSELx register. Digital output functions may continue to control the pin when it is in Analog mode.

Analog outputs, when enabled, take priority over digital outputs and force the digital output driver into a high-impedance state.

The pin function priorities are as follows:

1. Configuration bits
2. Analog outputs (disable the input buffers)
3. Analog inputs
4. Port inputs and outputs from PPS

#### Related Links

[15. \(PPS\) Peripheral Pin Select Module](#)

## 14.4 PORTx Registers

In this section the generic names such as PORTx, LATx, TRISx, etc. can be associated with PORTA, PORTB, PORTC, etc, depending on availability per device (see related link below).

### Related Links

[14.1 PORT Availability](#)

### 14.4.1 Data Register

PORTx is a bidirectional port, and its corresponding data direction register is TRISx. Setting a TRISx bit ('1') will make the corresponding PORTx pin an input (i.e., disable the output driver). Clearing a TRISx bit ('0') will make the corresponding PORTx pin an output (i.e., it enables output driver and puts the contents of the output latch on the selected pin). The example below shows how to initialize PORTA.

Reading the PORTx register reads the status of the pins, whereas writing to it will write to the PORT latch. All write operations are read-modify-write operations. Therefore, a write to a port implies that the port pins are read, this value is modified and then written to the PORT data latch (LATx).

The PORT data latch LATx holds the output port data and contains the latest value of a LATx or PORTx write.

#### Example 14-1. EXAMPLE-1: Initializing PORTA

```
; This code example illustrates initializing the PORTA register.
; The other ports are initialized in the same manner.

BANKSEL    PORTA        ;
CLRF       PORTA        ;Init PORTA
BANKSEL    LATA         ;Data Latch
CLRF       LATA         ;
BANKSEL    ANSELA       ;
CLRF       ANSELA       ;digital I/O
BANKSEL    TRISA        ;
MOVLW     B'00111000'   ;Set RA<5:3> as inputs
MOVWF     TRISA         ;and set RA<2:0> as outputs
```

### 14.4.2 Direction Control

The TRISx register controls the PORTx pin output drivers, even when they are being used as analog inputs. The user should ensure the bits in the TRISx register are maintained set when using them as analog inputs. I/O pins configured as analog inputs always read '0'.

### 14.4.3 Open-Drain Control

The ODCONx register controls the open-drain feature of the port. Open-drain operation is independently selected for each pin. When an ODCONx bit is set, the corresponding port output becomes an open-drain driver capable of sinking current only. When an ODCONx bit is cleared, the corresponding port output pin is the standard push-pull drive capable of sourcing and sinking current.



**Important:** It is not necessary to set open-drain control when using the pin for I<sup>2</sup>C; the I<sup>2</sup>C module controls the pin and makes the pin open-drain.

#### 14.4.4 Slew Rate Control

The SLRCONx register controls the slew rate option for each port pin. Slew rate for each port pin can be controlled independently. When an SLRCONx bit is set, the corresponding port pin drive is slew rate limited. When an SLRCONx bit is cleared, The corresponding port pin drive slews at the maximum rate possible.

#### 14.4.5 Input Threshold Control

The INLVLx register controls the input voltage threshold for each of the available PORTx input pins. A selection between the Schmitt Trigger CMOS or the TTL compatible thresholds is available. The input threshold is important in determining the value of a read of the PORTx register and also the level at which an interrupt-on-change occurs, if that feature is enabled. See link below for more information on threshold levels.



**Important:** Changing the input threshold selection should be performed while all peripheral modules are disabled. Changing the threshold level during the time a module is active may inadvertently generate a transition associated with an input pin, regardless of the actual voltage level on that pin.

#### 14.4.6 Analog Control

The ANSELx register is used to configure the Input mode of an I/O pin to analog. Setting the appropriate ANSELx bit high will cause all digital reads on the pin to be read as '0' and allow analog functions on the pin to operate correctly.

The state of the ANSELx bits has no effect on digital output functions. A pin with TRIS clear and ANSEL set will still operate as a digital output, but the Input mode will be analog. This can cause unexpected behavior when executing READ-MODIFY-WRITE instructions on the affected port.



**Important:** The ANSELx bits default to the Analog mode after Reset. To use any pins as digital general purpose or peripheral inputs, the corresponding ANSEL bits must be initialized to '0' by user software.

#### 14.4.7 Weak Pull-up Control

The WPUx register controls the individual weak pull-ups for each port pin.

#### 14.4.8 PORTx Functions and Output Priorities

Each PORTx pin is multiplexed with other functions.

Each pin defaults to the PORT latch data after Reset. Other output functions are selected with the peripheral pin select logic, or by enabling an analog output, such as the DAC. See the link below for more information.

Analog input functions, such as ADC and comparator inputs are not shown in the peripheral pin select lists. Digital output functions may continue to control the pin when it is in Analog mode.

#### Related Links

[15. \(PPS\) Peripheral Pin Select Module](#)

## 14.5 PORTE Registers

### Example 14-2. EXAMPLE-2: Initializing PORTE

```

CLRF      PORTE      ; Initialize PORTE by
                  ; clearing output
                  ; data latches
CLRF      LATE       ; Alternate method
                  ; to clear output
                  ; data latches
CLRF      ANSELE     ; Configure analog pins
                  ; for digital only
MOVLW    05h        ; Value used to
                  ; initialize data
                  ; direction
MOVWF    TRISE      ; Set RE<0> as input
                  ; RE<1> as output
                  ; RE<2> as input

```

#### 14.5.1 PORTE on 28-Pin Devices

For 28-pin devices, PORTE is only available when Master Clear functionality is disabled (MCLRE = 0). In this case, PORTE is a single bit, input-only port comprised of RE3 only. The pin operates as previously described. RE3 in PORTE register is a read-only bit and will read '1' when MCLRE = 1 (i.e., Master Clear enabled).

#### 14.5.2 RE3 Weak Pull-Up

The port RE3 pin has an individually controlled weak internal pull-up. When set, the WPUE3 bit enables the RE3 pin pull-up. When the RE3 port pin is configured as  $\overline{\text{MCLR}}$ , (CONFIG2L, MCLRE = 1 and CONFIG4H, LVP = 0), or configured for Low-Voltage Programming, (MCLRE = x and LVP = 1), the pull-up is always enabled and the WPUE3 bit has no effect.

#### 14.5.3 PORTE Interrupt-on-Change

The interrupt-on-change feature is available only on the RE3 pin for all devices.



14.6 Register Summary - Input/Output

Address	Name	Bit Pos.								
0x0C	PORTA	7:0	RA7	RA6	RA5	RA4	RA3	RA2	RA1	RA0
0x0D	PORTB	7:0	RB7	RB6	RB5	RB4	RB3	RB2	RB1	RB0
0x0E	PORTC	7:0	RC7	RC6	RC5	RC4	RC3	RC2	RC1	RC0
0x0F	Reserved									
0x10	PORTE	7:0					RE3			
0x11	Reserved									
0x12	TRISA	7:0	TRISA7	TRISA6	TRISA5	TRISA4	TRISA3	TRISA2	TRISA1	TRISA0
0x13	TRISB	7:0	TRISB7	TRISB6	TRISB5	TRISB4	TRISB3	TRISB2	TRISB1	TRISB0
0x14	TRISC	7:0	TRISC7	TRISC6	TRISC5	TRISC4	TRISC3	TRISC2	TRISC1	TRISC0
0x15	Reserved									
...										
0x17										
0x18	LATA	7:0	LATA7	LATA6	LATA5	LATA4	LATA3	LATA2	LATA1	LATA0
0x19	LATB	7:0	LATB7	LATB6	LATB5	LATB4	LATB3	LATB2	LATB1	LATB0
0x1A	LATC	7:0	LATC7	LATC6	LATC5	LATC4	LATC3	LATC2	LATC1	LATC0
0x1B	Reserved									
...										
0x1F37										
0x1F38		ANSELA	7:0	ANSELA7	ANSELA6	ANSELA5	ANSELA4	ANSELA3	ANSELA2	ANSELA1
0x1F39	WPUA	7:0	WPUA7	WPUA6	WPUA5	WPUA4	WPUA3	WPUA2	WPUA1	WPUA0
0x1F3A	ODCONA	7:0	ODCA7	ODCA6	ODCA5	ODCA4	ODCA3	ODCA2	ODCA1	ODCA0
0x1F3B	SLRCONA	7:0	SLRA7	SLRA6	SLRA5	SLRA4	SLRA3	SLRA2	SLRA1	SLRA0
0x1F3C	INLVLA	7:0	INLVLA7	INLVLA6	INLVLA5	INLVLA4	INLVLA3	INLVLA2	INLVLA1	INLVLA0
0x1F3D	Reserved									
...										
0x1F42										
0x1F43	ANSELB	7:0	ANSELB7	ANSELB6	ANSELB5	ANSELB4	ANSELB3	ANSELB2	ANSELB1	ANSELB0
0x1F44	WPUB	7:0	WPUB7	WPUB6	WPUB5	WPUB4	WPUB3	WPUB2	WPUB1	WPUB0
0x1F45	ODCONB	7:0	ODCB7	ODCB6	ODCB5	ODCB4	ODCB3	ODCB2	ODCB1	ODCB0
0x1F46	SLRCONB	7:0	SLRB7	SLRB6	SLRB5	SLRB4	SLRB3	SLRB2	SLRB1	SLRB0
0x1F47	INVLB	7:0	INVLB7	INVLB6	INVLB5	INVLB4	INVLB3	INVLB2	INVLB1	INVLB0
0x1F48	Reserved									
...										
0x1F4D										
0x1F4E	ANSELC	7:0	ANSELC7	ANSELC6	ANSELC5	ANSELC4	ANSELC3	ANSELC2	ANSELC1	ANSELC0
0x1F4F	WPUC	7:0	WPUC7	WPUC6	WPUC5	WPUC4	WPUC3	WPUC2	WPUC1	WPUC0
0x1F50	ODCONC	7:0	ODCC7	ODCC6	ODCC5	ODCC4	ODCC3	ODCC2	ODCC1	ODCC0
0x1F51	SLRCONC	7:0	SLRC7	SLRC6	SLRC5	SLRC4	SLRC3	SLRC2	SLRC1	SLRC0
0x1F52	INLVLC	7:0	INLVLC7	INLVLC6	INLVLC5	INLVLC4	INLVLC3	INLVLC2	INLVLC1	INLVLC0
0x1F53	Reserved									
...										
0x1F64										
0x1F65	WPUE	7:0					WPUE3			
0x1F66	Reserved									

---

---

Address	Name	Bit Pos.								
...										
0x1F67										
0x1F68	INLVLE	7:0					INLVLE3			

**14.7 Register Definitions: Port Control**

14.7.1 PORTA

**Name:** PORTA

**Address:** 0x00C

PORTA Register

**Note:** Writes to PORTA are actually written to the corresponding LATA register.

Reads from PORTA register return actual I/O pin values.

Bit	7	6	5	4	3	2	1	0
	RA7	RA6	RA5	RA4	RA3	RA2	RA1	RA0
Access	R/W	R/W	R/W	R/W	R/W	R/W	R/W	R/W
Reset	x	x	x	x	x	x	x	x

**Bits 0, 1, 2, 3, 4, 5, 6, 7 – RAn** Port I/O Value bits

Reset States: POR/BOR = xxxxxxxx

All Other Resets = uuuuuuuu

Value	Description
1	Port pin is $\geq V_{IH}$
0	Port pin is $\leq V_{IL}$

14.7.2 PORTB

**Name:** PORTB

**Address:** 0x00D

PORTB Register

Bit	7	6	5	4	3	2	1	0
	RB7	RB6	RB5	RB4	RB3	RB2	RB1	RB0
Access	R/W	R/W	R/W	R/W	R/W	R/W	R/W	R/W
Reset	x	x	x	x	x	x	x	x

**Bits 0, 1, 2, 3, 4, 5, 6, 7 – RBn** Port I/O Value bits

**Note:** Bits RB6 and RB7 read '1' while in Debug mode.

Reset States: POR/BOR = xxxxxxxx

All Other Resets = uuuuuuuu

Value	Description
1	Port pin is $\geq V_{IH}$
0	Port pin is $\leq V_{IL}$

**Note:** Writes to PORTB are actually written to the corresponding LATB register.

Reads from PORTB register return actual I/O pin values.

14.7.3 PORTC

**Name:** PORTC

**Address:** 0x00E

PORTC Register

Bit	7	6	5	4	3	2	1	0
	RC7	RC6	RC5	RC4	RC3	RC2	RC1	RC0
Access	R/W	R/W	R/W	R/W	R/W	R/W	R/W	R/W
Reset	x	x	x	x	x	x	x	x

**Bits 0, 1, 2, 3, 4, 5, 6, 7 – RCn** Port I/O Value bits

Reset States: POR/BOR = xxxxxxxx

All Other Resets = uuuuuuuu

Value	Description
1	Port pin is $\geq V_{IH}$
0	Port pin is $\leq V_{IL}$

**Note:** Writes to PORTC are actually written to the corresponding LATC register.

Reads from PORTC register return actual I/O pin values.

14.7.4 PORTE

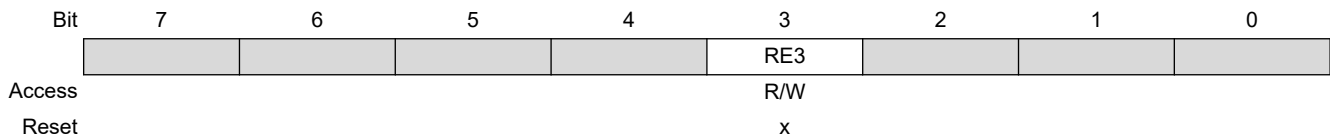
**Name:** PORTE

**Address:** 0x010

PORTE Register

**Note:** Writes to PORTE are actually written to the corresponding LATE register.

Reads from PORTE register return actual I/O pin values.



**Bit 3 – RE3** Port I/O Value bits

**Note:** Bit RE3 is read-only, and will read '1' when MCLRE = 1 (Master Clear enabled).

Reset States: POR/BOR = x

All Other Resets = u

Value	Description
1	Port pin is $\geq V_{IH}$
0	Port pin is $\leq V_{IL}$

14.7.5 TRISA

**Name:** TRISA

**Address:** 0x012

Tri-State Control Register

Bit	7	6	5	4	3	2	1	0
	TRISA7	TRISA6	TRISA5	TRISA4	TRISA3	TRISA2	TRISA1	TRISA0
Access	R/W	R/W	R/W	R/W	R/W	R/W	R/W	R/W
Reset	1	1	1	1	1	1	1	1

**Bits 0, 1, 2, 3, 4, 5, 6, 7 – TRISAn** TRISA Port I/O Tri-state Control bits

Value	Description
1	Port output driver is disabled
0	Port output driver is enabled

14.7.6 TRISB

**Name:** TRISB

**Address:** 0x013

Tri-State Control Register

Bit	7	6	5	4	3	2	1	0
	TRISB7	TRISB6	TRISB5	TRISB4	TRISB3	TRISB2	TRISB1	TRISB0
Access	R/W	R/W	R/W	R/W	R/W	R/W	R/W	R/W
Reset	1	1	1	1	1	1	1	1

**Bits 0, 1, 2, 3, 4, 5, 6, 7 – TRISBn** TRISB Port I/O Tri-state Control bits

**Note:** Bits TRISB6 and TRISB7 read '1' while in Debug mode.

Value	Description
1	Port output driver is disabled
0	Port output driver is enabled



14.7.7 TRISC

**Name:** TRISC

**Address:** 0x014

Tri-State Control Register

Bit	7	6	5	4	3	2	1	0
	TRISC7	TRISC6	TRISC5	TRISC4	TRISC3	TRISC2	TRISC1	TRISC0
Access	R/W	R/W	R/W	R/W	R/W	R/W	R/W	R/W
Reset	1	1	1	1	1	1	1	1

**Bits 0, 1, 2, 3, 4, 5, 6, 7 – TRISCn** TRISC Port I/O Tri-state Control bits

Value	Description
1	Port output driver is disabled
0	Port output driver is enabled

14.7.8 LATA

**Name:** LATA  
**Address:** 0x018

Output Latch Register

Bit	7	6	5	4	3	2	1	0
	LATA7	LATA6	LATA5	LATA4	LATA3	LATA2	LATA1	LATA0
Access	R/W	R/W	R/W	R/W	R/W	R/W	R/W	R/W
Reset	x	x	x	x	x	x	x	x

**Bits 0, 1, 2, 3, 4, 5, 6, 7 – LATAn** Output Latch A Value bits

Reset States: POR/BOR = xxxxxxxx

All Other Resets = uuuuuuuu

**Note:** Writes to LATA are equivalent with writes to the corresponding PORTA register. Reads from LATA register return register values, not I/O pin values.

14.7.9 LATB

**Name:** LATB  
**Address:** 0x019

Output Latch Register

Bit	7	6	5	4	3	2	1	0
	LATB7	LATB6	LATB5	LATB4	LATB3	LATB2	LATB1	LATB0
Access	R/W	R/W	R/W	R/W	R/W	R/W	R/W	R/W
Reset	x	x	x	x	x	x	x	x

**Bits 0, 1, 2, 3, 4, 5, 6, 7 – LATBn** Output Latch B Value bits

Reset States: POR/BOR = xxxxxxxx

All Other Resets = uuuuuuuu

**Note:** Writes to LATB are equivalent with writes to the corresponding PORTB register. Reads from LATB register return register values, not I/O pin values.

14.7.10 LATC

**Name:** LATC  
**Address:** 0x01A

Output Latch Register

Bit	7	6	5	4	3	2	1	0
	LATC7	LATC6	LATC5	LATC4	LATC3	LATC2	LATC1	LATC0
Access	R/W	R/W	R/W	R/W	R/W	R/W	R/W	R/W
Reset	x	x	x	x	x	x	x	x

**Bits 0, 1, 2, 3, 4, 5, 6, 7 – LATCn** Output Latch C Value bits

Reset States: POR/BOR = xxxxxxxx

All Other Resets = uuuuuuuu

**Note:** Writes to LATC are equivalent with writes to the corresponding PORTC register. Reads from LATC register return register values, not I/O pin values.

14.7.11 ANSELA

**Name:** ANSELA

**Address:** 0x1F38

Analog Select Register

Bit	7	6	5	4	3	2	1	0
	ANSELA7	ANSELA6	ANSELA5	ANSELA4	ANSELA3	ANSELA2	ANSELA1	ANSELA0
Access	R/W	R/W	R/W	R/W	R/W	R/W	R/W	R/W
Reset	1	1	1	1	1	1	1	1

**Bits 0, 1, 2, 3, 4, 5, 6, 7 – ANSELAn** Analog Select on Pins RA<7:0>

Value	Description
1	Digital Input buffers are disabled
0	ST and TTL input buffers are enabled

14.7.12 ANSELB

**Name:** ANSELB  
**Address:** 0x1F43  
**Reset:** 0x00

Analog Select Register

Bit	7	6	5	4	3	2	1	0
	ANSELB7	ANSELB6	ANSELB5	ANSELB4	ANSELB3	ANSELB2	ANSELB1	ANSELB0
Access	R/W	R/W	R/W	R/W	R/W	R/W	R/W	R/W
Reset	1	1	1	1	1	1	1	1

**Bits 0, 1, 2, 3, 4, 5, 6, 7 – ANSELBn** Analog Select on Pins RB<7:0>

Value	Description
1	Digital Input buffers are disabled
0	ST and TTL input buffers are enabled

14.7.13 ANSELC

**Name:** ANSELC

**Address:** 0x1F4E

Analog Select Register

Bit	7	6	5	4	3	2	1	0
	ANSEL7	ANSEL6	ANSEL5	ANSEL4	ANSEL3	ANSEL2	ANSEL1	ANSEL0
Access	R/W	R/W	R/W	R/W	R/W	R/W	R/W	R/W
Reset	1	1	1	1	1	1	1	1

**Bits 0, 1, 2, 3, 4, 5, 6, 7 – ANSEL<sub>n</sub>** Analog Select on Pins RC<7:0>

Value	Description
1	Digital Input buffers are disabled
0	ST and TTL input buffers are enabled

14.7.14 WPUA

**Name:** WPUA  
**Address:** 0x1F39

Weak Pull-up Register

Bit	7	6	5	4	3	2	1	0
	WPUA7	WPUA6	WPUA5	WPUA4	WPUA3	WPUA2	WPUA1	WPUA0
Access	R/W	R/W	R/W	R/W	R/W	R/W	R/W	R/W
Reset	0	0	0	0	0	0	0	0

**Bits 0, 1, 2, 3, 4, 5, 6, 7 – WPUAn** Weak Pull-up PORTA Control bits

Value	Description
1	Weak Pull-up enabled
0	Weak Pull-up disabled



14.7.15 WPUB

**Name:** WPUB  
**Address:** 0x1F44

Weak Pull-up Register

Bit	7	6	5	4	3	2	1	0
	WPUB7	WPUB6	WPUB5	WPUB4	WPUB3	WPUB2	WPUB1	WPUB0
Access	R/W	R/W	R/W	R/W	R/W	R/W	R/W	R/W
Reset	0	0	0	0	0	0	0	0

**Bits 0, 1, 2, 3, 4, 5, 6, 7 – WPUBn** Weak Pull-up PORTA Control bits

Value	Description
1	Weak Pull-up enabled
0	Weak Pull-up disabled

14.7.16 WPUC

**Name:** WPUC  
**Address:** 0x1F4F

Weak Pull-up Register

Bit	7	6	5	4	3	2	1	0
	WPUC7	WPUC6	WPUC5	WPUC4	WPUC3	WPUC2	WPUC1	WPUC0
Access	R/W	R/W	R/W	R/W	R/W	R/W	R/W	R/W
Reset	0	0	0	0	0	0	0	0

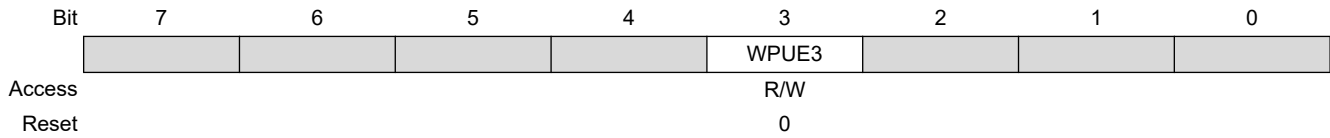
**Bits 0, 1, 2, 3, 4, 5, 6, 7 – WPUCn** Weak Pull-up PORTC Control bits

Value	Description
1	Weak Pull-up enabled
0	Weak Pull-up disabled

14.7.17 WPUE

**Name:** WPUE  
**Address:** 0x1F65

Weak Pull-up Register



**Bit 3 – WPUE3** Weak Pull-up PORTE Control bits

**Note:** If MCLRE = 1, the weak pull-up in RE3 is always enabled; bit WPUE3 is not affected.

Value	Description
1	Weak Pull-up enabled
0	Weak Pull-up disabled

14.7.18 ODCONA

**Name:** ODCONA

**Address:** 0x1F3A

Open-Drain Control Register

Bit	7	6	5	4	3	2	1	0
	ODCA7	ODCA6	ODCA5	ODCA4	ODCA3	ODCA2	ODCA1	ODCA0
Access	R/W	R/W	R/W	R/W	R/W	R/W	R/W	R/W
Reset	0	0	0	0	0	0	0	0

**Bits 0, 1, 2, 3, 4, 5, 6, 7 – ODCAn** Open-Drain Configuration on Pins Rx<7:0>

Value	Description
1	Output drives only low-going signals (sink current only)
0	Output drives both high-going and low-going signals (source and sink current)

14.7.19 ODCONB

**Name:** ODCONB

**Address:** 0x1F45

Open-Drain Control Register

Bit	7	6	5	4	3	2	1	0
	ODCB7	ODCB6	ODCB5	ODCB4	ODCB3	ODCB2	ODCB1	ODCB0
Access	R/W	R/W	R/W	R/W	R/W	R/W	R/W	R/W
Reset	0	0	0	0	0	0	0	0

**Bits 0, 1, 2, 3, 4, 5, 6, 7 – ODCBn** Open-Drain Configuration on Pins Rx<7:0>

Value	Description
1	Output drives only low-going signals (sink current only)
0	Output drives both high-going and low-going signals (source and sink current)

14.7.20 ODCONC

**Name:** ODCONC

**Address:** 0x1F50

Open-Drain Control Register

Bit	7	6	5	4	3	2	1	0
	ODCC7	ODCC6	ODCC5	ODCC4	ODCC3	ODCC2	ODCC1	ODCC0
Access	R/W	R/W	R/W	R/W	R/W	R/W	R/W	R/W
Reset	0	0	0	0	0	0	0	0

**Bits 0, 1, 2, 3, 4, 5, 6, 7 – ODCCn** Open-Drain Configuration on Pins Rx<7:0>

Value	Description
1	Output drives only low-going signals (sink current only)
0	Output drives both high-going and low-going signals (source and sink current)

14.7.21 SLRCONA

**Name:** SLRCONA

**Address:** 0x1F3B

Slew Rate Control Register

Bit	7	6	5	4	3	2	1	0
	SLRA7	SLRA6	SLRA5	SLRA4	SLRA3	SLRA2	SLRA1	SLRA0
Access	R/W	R/W	R/W	R/W	R/W	R/W	R/W	R/W
Reset	1	1	1	1	1	1	1	1

**Bits 0, 1, 2, 3, 4, 5, 6, 7 – SLRA<sub>n</sub>** Slew Rate Control on Pins Rx<7:0>, respectively

Value	Description
1	Port pin slew rate is limited
0	Port pin slews at maximum rate

14.7.22 SLRCONB

**Name:** SLRCONB

**Address:** 0x1F46

Slew Rate Control Register

Bit	7	6	5	4	3	2	1	0
	SLRB7	SLRB6	SLRB5	SLRB4	SLRB3	SLRB2	SLRB1	SLRB0
Access	R/W	R/W	R/W	R/W	R/W	R/W	R/W	R/W
Reset	1	1	1	1	1	1	1	1

**Bits 0, 1, 2, 3, 4, 5, 6, 7 – SLRBn** Slew Rate Control on Pins Rx<7:0>, respectively

Value	Description
1	Port pin slew rate is limited
0	Port pin slews at maximum rate



14.7.23 SLRCONC

**Name:** SLRCONC

**Address:** 0x1F51

Slew Rate Control Register

Bit	7	6	5	4	3	2	1	0
	SLRC7	SLRC6	SLRC5	SLRC4	SLRC3	SLRC2	SLRC1	SLRC0
Access	R/W	R/W	R/W	R/W	R/W	R/W	R/W	R/W
Reset	1	1	1	1	1	1	1	1

**Bits 0, 1, 2, 3, 4, 5, 6, 7 – SLRCn** Slew Rate Control on Pins Rx<7:0>, respectively

Value	Description
1	Port pin slew rate is limited
0	Port pin slews at maximum rate

14.7.24 INLVLA

**Name:** INLVLA  
**Address:** 0x1F3C

Input Level Control Register

Bit	7	6	5	4	3	2	1	0
	INLVLA7	INLVLA6	INLVLA5	INLVLA4	INLVLA3	INLVLA2	INLVLA1	INLVLA0
Access	R/W	R/W	R/W	R/W	R/W	R/W	R/W	R/W
Reset	1	1	1	1	1	1	1	1

**Bits 0, 1, 2, 3, 4, 5, 6, 7 – INLVLA<sub>n</sub>** Input Level Select on Pins Rx<7:0>, respectively

Value	Description
1	ST input used for port reads and interrupt-on-change
0	TTL input used for port reads and interrupt-on-change

14.7.25 INLVLB

**Name:** INLVLB

**Address:** 0x1F47

Input Level Control Register

Bit	7	6	5	4	3	2	1	0
	INLVLB7	INLVLB6	INLVLB5	INLVLB4	INLVLB3	INLVLB2	INLVLB1	INLVLB0
Access	R/W	R/W	R/W	R/W	R/W	R/W	R/W	R/W
Reset	1	1	1	1	1	1	1	1

**Bits 0, 1, 2, 3, 4, 5, 6, 7 – INLVLBn** Input Level Select on Pins Rx<7:0>, respectively

**Note:** INLVLB2 / INLVLB1: Pins read the I<sup>2</sup>C ST inputs when MSSP inputs select these pins, and I<sup>2</sup>C mode is enabled.

Value	Description
1	ST input used for port reads and interrupt-on-change
0	TTL input used for port reads and interrupt-on-change

14.7.26 INLVLC

**Name:** INLVLC

**Address:** 0x1F52

Input Level Control Register

Bit	7	6	5	4	3	2	1	0
	INLVLC7	INLVLC6	INLVLC5	INLVLC4	INLVLC3	INLVLC2	INLVLC1	INLVLC0
Access	R/W	R/W	R/W	R/W	R/W	R/W	R/W	R/W
Reset	1	1	1	1	1	1	1	1

**Bits 0, 1, 2, 3, 4, 5, 6, 7 – INLVLCn** Input Level Select on Pins Rx<7:0>, respectively

**Note:** INLVLC4 / INLVLC3: Pins read the I<sup>2</sup>C ST inputs when MSSP inputs select these pins, and I<sup>2</sup>C mode is enabled.

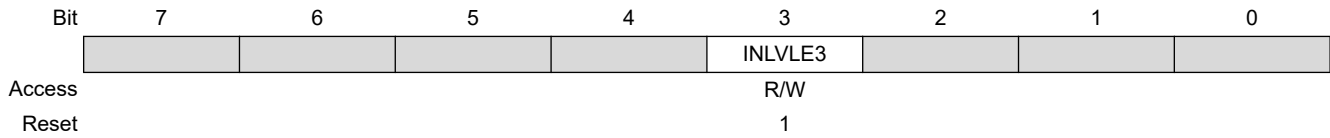
Value	Description
1	ST input used for port reads and interrupt-on-change
0	TTL input used for port reads and interrupt-on-change

14.7.27 INLVLE

**Name:** INLVLE

**Address:** 0x1F68

Input Level Control Register



**Bit 3 – INLVLE3** Input Level Select on Pins Rx<7:0>, respectively

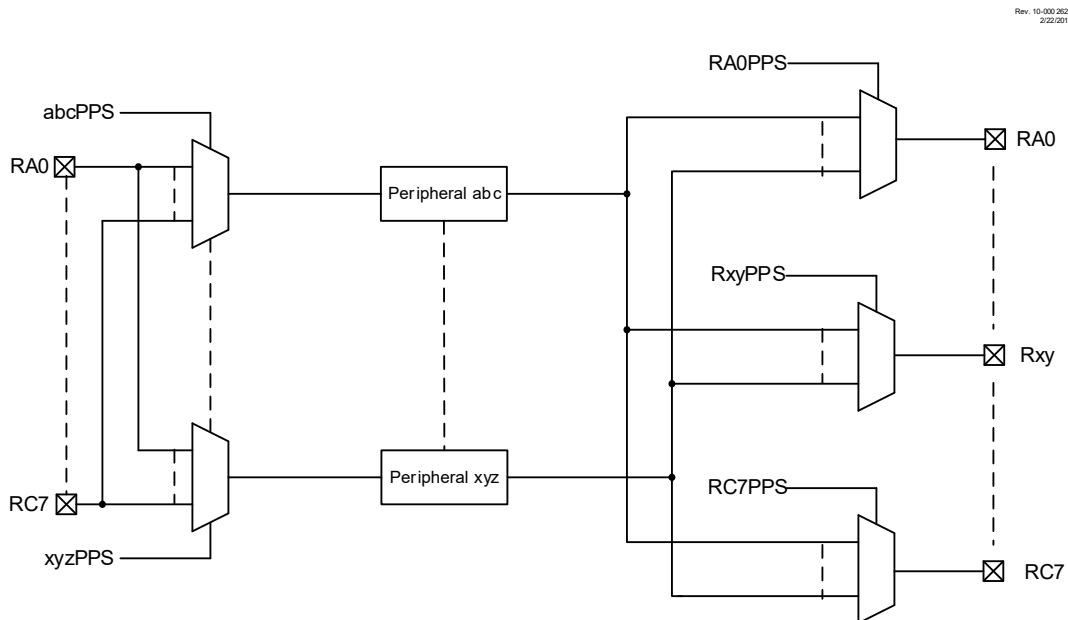
Value	Description
1	ST input used for port reads and interrupt-on-change
0	TTL input used for port reads and interrupt-on-change

## 15. (PPS) Peripheral Pin Select Module

The Peripheral Pin Select (PPS) module connects peripheral inputs and outputs to the device I/O pins. Only digital signals are included in the selections.

All analog inputs and outputs remain fixed to their assigned pins. Input and output selections are independent as shown in the figure below.

**Figure 15-1. Simplified PPS Block Diagram**



Rev. 10-000-262B  
2/22/2017

### 15.1 PPS Inputs

Each peripheral has an xxxPPS register with which the input pin to the peripheral is selected. Not all ports are available for input as shown in the following table.

Multiple peripherals can operate from the same source simultaneously. Port reads always return the pin level regardless of peripheral PPS selection. If a pin also has analog functions associated, the ANSEL bit for that pin must be cleared to enable the digital input buffer.



**Important:** The notation “xxx” in the generic register name is a place holder for the peripheral identifier. For example, xxx = INT for the INTPPS register.

**Table 15-1. PPS Input Signal Routing Options**

Input Signal Name	Input Register Name	Default Location at POR	Reset Value (xxxPPS<4:0>)	PORT From Which Input Is Available		
INT0	INT0PPS	RB0	0 1000	A	B	—
T0CKI	T0CKIPPS	RA4	0 0100	A	B	—

# PIC16(L)F18455/56

## (PPS) Peripheral Pin Select Module

Input Signal Name	Input Register Name	Default Location at POR	Reset Value (xxxPPS<4:0>)	PORT From Which Input Is Available		
T1CKI	T1CKIPPS	RC0	1 0000	A	—	C
T1G	T1GPPS	RB5	0 1101	—	B	C
T2IN	T2INPPS	RC3	1 0011	A	—	C
T3CKI	T3CKIPPS	RC0	1 0000	—	B	C
T3G	T3GPPS	RC0	1 0000	A	—	C
T4IN	T4INPPS	RC5	1 0101	—	B	C
T5CKI	T5CKIPPS	RC2	1 0010	A	—	C
T5G	T5GPPS	RB4	0 1100	—	B	C
T6IN	T6INPPS	RB7	0 1111	—	B	C
MDCARL	MDCARLPPS	RA3	0 0001	A	—	C
MDCARH	MDCARHPPS	RA4	0 0100	A	—	C
MDSRC	MDSRCPPS	RA5	0 0101	A	—	C
CCP1IN	CCP1INPPS	RC2	1 0010	—	B	C
CCP2IN	CCP2INPPS	RC1	1 0001	—	B	C
CCP3IN	CCP3INPPS	RB5	0 1101	—	B	C
CCP4IN	CCP4INPPS	RB0	0 1000	—	B	C
CCP5IN	CCP5INPPS	RA4	0 0100	A	—	C
CWG1IN	CWG1INPPS	RB0	0 1000	—	B	C
CWG2IN	CWG2INPPS	RB1	0 1001	—	B	C
CWG3IN	CWG3INPPS	RB2	0 1000	—	B	C
CLCIN0	CLCIN0PPS	RA0	0 0000	A	—	C
CLCIN1	CLCIN1PPS	RA1	0 0001	A	—	C
CLCIN2	CLCIN2PPS	RB6	0 1110	—	B	C
CLCIN3	CLCIN3PPS	RB7	0 1111	—	B	C
ADACT	ADACTPPS	RB4	0 1100	—	B	C
SCK1	SCL1PPS	RC3	1 0011	—	B	C
SCL1	SCL1PPS	RC3	1 0011	—	B	C
SDI1	SDA1PPS	RC4	1 0100	—	B	C
SDA1	SDA1PPS	RC4	1 0100	—	B	C
SS1	SS1PPS	RA5	0 0101	A	—	C

Input Signal Name	Input Register Name	Default Location at POR	Reset Value (xxxPPS<4:0>)	PORT From Which Input Is Available		
SCK2	SCL2PPS	RB1	0 1001	—	B	C
SCL2	SCL2PPS	RB1	0 1001	—	B	C
SDI2	SDA2PPS	RB2	0 1000	—	B	C
SDA2	SDA2PPS	RB2	0 1000	—	B	C
SS2	SS2PPS	RB2	0 1000	—	B	C
RX1	RX1PPS	RC7	1 0111	—	B	C
DT1	RX1PPS	RC7	1 0111	—	B	C
TX1	CK1PPS	RC6	1 0110	—	B	C
CK1	CK1PPS	RC6	1 0110	—	B	C
RX2	RX2PPS	RB7	0 1111	—	B	C
DT2	RX2PPS	RB7	0 1111	—	B	C
TX2	CK2PPS	RB6	0 1110	—	B	C
CK2	CK2PPS	RB6	0 1110	—	B	C
SMT1SIG	SMT1SIGPPS	RC1	1 0001	—	B	C
SMT1WIN	SMT1WINPPS	RC0	1 0000	—	B	C
SMT2SIG	SMT2SIGPPS	RB5	0 1101	—	B	C
SMT2WIN	SMT2WINPPS	RB4	0 1100	—	B	C

## 15.2 PPS Outputs

Each I/O pin has an RxyPPS register with which the pin output source is selected. With few exceptions, the port TRIS control associated with that pin retains control over the pin output driver. Peripherals that control the pin output driver as part of the peripheral operation will override the TRIS control as needed. These peripherals include:

- EUSART (synchronous operation)
- MSSP (I<sup>2</sup>C)

Although every pin has its own RxyPPS peripheral selection register, the selections are identical for every pin as shown in the following table.



**Important:** The notation “Rxy” is a place holder for the pin identifier. The 'x' holds the place of the PORT letter and the 'y' holds the place of the bit number. For example, Rxy = RA0 for the RA0PPS register.



**Table 15-2. PPS Output Signal Routing Options**

Output Signal Name	RxyPPS Register Value
ADCGRDA	0x1F
ADCGRDB	0x20
C1OUT	0x11
C2OUT	0x12
CCP1OUT	0x09
CCP2OUT	0x0A
CCP3OUT	0x0B
CCP4OUT	0x0C
CCP5OUT	0x27
CLC1OUT	0x01
CLC2OUT	0x02
CLC3OUT	0x03
CLC4OUT	0x04
CK1 <sup>(1)</sup> /TX1	0x0F
CK2 <sup>(1)</sup> /TX2	0x25
CLKR	0x19
CWG1A	0x05
CWG1B	0x06
CWG1C	0x07
CWG1D	0x08
CWG2A	0x1B
CWG2B	0x1C
CWG2C	0x1D
CWG2D	0x1E
CWG3A	0x21
CWG3B	0x22
CWG3C	0x23
CWG3D	0x24
DSM1OUT	0x1A
DT1 <sup>(1)</sup>	0x10
DT2 <sup>(1)</sup>	0x26

Output Signal Name	RxyPPS Register Value
NCO1OUT	0x18
PWM6OUT	0x0D
PWM7OUT	0x0E
SCK1	0x13
SCL1	0x13
SDA1	0x14
SDO1	0x14
SCK2	0x15
SCL2	0x15
SDA2	0x16
SDO2	0x16
TMR0OUT	0x17

**Note:**

- CK1/CK2 and DT1/DT2 are bidirectional signals used in EUSART Synchronous mode.

### 15.3 Bidirectional Pins

PPS selections for peripherals with bidirectional signals on a single pin must be made so that the PPS input and PPS output select the same pin. Peripherals that have bidirectional signals include:

- EUSART (DT/RXxPPS and TX/CKxPPS pins for synchronous operation)
- MSSP (I<sup>2</sup>C SDA/SSPxDATPPS and SCL/SSPxCLKPPS)



**Important:** The I<sup>2</sup>C default inputs, and a limited number of other alternate pins, are I<sup>2</sup>C and SMBus compatible. Clock and data signals can be routed to any pin, however pins without I<sup>2</sup>C compatibility will operate at standard TTL/ST logic levels as selected by the INLVL register. See the INLVL register for each port to determine which pins are I<sup>2</sup>C and SMBus compatible.

### 15.4 PPS Lock

The PPS includes a mode in which all input and output selections can be locked to prevent inadvertent changes. PPS selections are locked by setting the PPSLOCKED bit of the PPSLOCK register. Setting and clearing this bit requires a special sequence as an extra precaution against inadvertent changes. Examples of setting and clearing the PPSLOCKED bit are shown in the following examples.

#### Example 15-1. PPS Lock Sequence

```

; suspend interrupts
BCF     INTCON,GIE
BANKSEL PPSLOCK ; set bank

```

```
 ; required sequence, next 5 instructions
MOVW  0x55
MOVWF  PPSLOCK
MOVW  0xAA
MOVWF  PPSLOCK
 ; Set PPSLOCKED bit to disable writes or
BSF   PPSLOCK,PPSLOCKED
 ; restore interrupts
BSF   INTCON,GIE
```

#### Example 15-2. PPS Unlock Sequence

```
 ; suspend interrupts
BCF   INTCON,GIE
BANKSEL PPSLOCK ; set bank
 ; required sequence, next 5 instructions
MOVW  0x55
MOVWF  PPSLOCK
MOVW  0xAA
MOVWF  PPSLOCK
 ; Clear PPSLOCKED bit to enable writes
BCF   PPSLOCK,PPSLOCKED
 ; restore interrupts
BSF   INTCON,GIE
```

**Note:**

1. The PPSLOCK bit can only be set or cleared after the unlock sequence shown above.
2. If PPS1WAY = 1, the PPSLOCK bit cannot be cleared after it has been set.

## 15.5 PPS Permanent Lock

The PPS can be permanently locked by setting the PPS1WAY Configuration bit. When this bit is set, the PPSLOCKED bit can only be cleared and set one time after a device Reset. This allows for clearing the PPSLOCKED bit so that the input and output selections can be made during initialization. When the PPSLOCKED bit is set after all selections have been made, it will remain set and cannot be cleared until after the next device Reset event.

**Related Links**

[15.9.3 PPSLOCK](#)

## 15.6 Operation During Sleep

PPS input and output selections are unaffected by Sleep.

## 15.7 Effects of a Reset

A device Power-on-Reset (POR) clears all PPS input and output selections to their default values. All other Resets leave the selections unchanged. Default input selections are shown in the [input selection register table](#). The PPS one-way is also removed.

## 15.8 Register Summary - PPS

Address	Name	Bit Pos.							
0x1E8F	PPSLOCK	7:0							PPSLOCKED
0x1E90	INTPPS	7:0				PORT[1:0]			PIN[2:0]
0x1E91	T0CKIPPS	7:0				PORT[1:0]			PIN[2:0]
0x1E92	T1CKIPPS	7:0				PORT[1:0]			PIN[2:0]
0x1E93	T1GPPS	7:0				PORT[1:0]			PIN[2:0]
0x1E94	T3CKIPPS	7:0				PORT[1:0]			PIN[2:0]
0x1E95	T3GPPS	7:0				PORT[1:0]			PIN[2:0]
0x1E96	T5CKIPPS	7:0				PORT[1:0]			PIN[2:0]
0x1E97	T5GPPS	7:0				PORT[1:0]			PIN[2:0]
0x1E98 ... 0x1E9B	Reserved								
0x1E9C	T2INPPS	7:0				PORT[1:0]			PIN[2:0]
0x1E9D	T4INPPS	7:0				PORT[1:0]			PIN[2:0]
0x1E9E	T6INPPS	7:0				PORT[1:0]			PIN[2:0]
0x1E9F ... 0x1EA0	Reserved								
0x1EA1	CCP1PPS	7:0				PORT[1:0]			PIN[2:0]
0x1EA2	CCP2PPS	7:0				PORT[1:0]			PIN[2:0]
0x1EA3	CCP3PPS	7:0				PORT[1:0]			PIN[2:0]
0x1EA4	CCP4PPS	7:0				PORT[1:0]			PIN[2:0]
0x1EA5	CCP5PPS	7:0				PORT[1:0]			PIN[2:0]
0x1EA6 ... 0x1EA8	Reserved								
0x1EA9	SMT1WINPPS	7:0				PORT[1:0]			PIN[2:0]
0x1EAA	SMT1SIGPPS	7:0				PORT[1:0]			PIN[2:0]
0x1EAB	SMT2WINPPS	7:0				PORT[1:0]			PIN[2:0]
0x1EAC	SMT2SIGPPS	7:0				PORT[1:0]			PIN[2:0]
0x1EAD ... 0x1EB0	Reserved								
0x1EB1	CWG1PPS	7:0				PORT[1:0]			PIN[2:0]
0x1EB2	CWG2PPS	7:0				PORT[1:0]			PIN[2:0]
0x1EB3	CWG3PPS	7:0				PORT[1:0]			PIN[2:0]
0x1EB4 ... 0x1EB7	Reserved								
0x1EB8	MDCARLPPS	7:0				PORT[1:0]			PIN[2:0]
0x1EB9	MDCARHPPS	7:0				PORT[1:0]			PIN[2:0]
0x1EBA	MDSRCPPS	7:0				PORT[1:0]			PIN[2:0]
0x1EBB	CLCIN0PPS	7:0				PORT[1:0]			PIN[2:0]
0x1EBC	CLCIN1PPS	7:0				PORT[1:0]			PIN[2:0]

# PIC16(L)F18455/56

## (PPS) Peripheral Pin Select Module

Address	Name	Bit Pos.							
0x1EBD	CLCIN2PPS	7:0				PORT[1:0]		PIN[2:0]	
0x1EBE	CLCIN3PPS	7:0				PORT[1:0]		PIN[2:0]	
0x1EBF	Reserved								
0x1EC2									
0x1EC3	ADACTPPS	7:0				PORT[1:0]		PIN[2:0]	
0x1EC4	Reserved								
0x1EC5	SSP1CLKPPS	7:0				PORT[1:0]		PIN[2:0]	
0x1EC6	SSP1DATPPS	7:0				PORT[1:0]		PIN[2:0]	
0x1EC7	SSP1SSPPS	7:0				PORT[1:0]		PIN[2:0]	
0x1EC8	SSP2CLKPPS	7:0				PORT[1:0]		PIN[2:0]	
0x1EC9	SSP2DATPPS	7:0				PORT[1:0]		PIN[2:0]	
0x1ECA	SSP2SSPPS	7:0				PORT[1:0]		PIN[2:0]	
0x1ECB	RX1PPS	7:0				PORT[1:0]		PIN[2:0]	
0x1ECC	CK1PPS	7:0				PORT[1:0]		PIN[2:0]	
0x1ECD	RX2PPS	7:0				PORT[1:0]		PIN[2:0]	
0x1ECE	CK2PPS	7:0				PORT[1:0]		PIN[2:0]	
0x1ECF	Reserved								
0x1F0F									
0x1F10	RA0PPS	7:0						PPS[5:0]	
0x1F11	RA1PPS	7:0						PPS[5:0]	
0x1F12	RA2PPS	7:0						PPS[5:0]	
0x1F13	RA3PPS	7:0						PPS[5:0]	
0x1F14	RA4PPS	7:0						PPS[5:0]	
0x1F15	RA5PPS	7:0						PPS[5:0]	
0x1F16	RA6PPS	7:0						PPS[5:0]	
0x1F17	RA7PPS	7:0						PPS[5:0]	
0x1F18	RB0PPS	7:0						PPS[5:0]	
0x1F19	RB1PPS	7:0						PPS[5:0]	
0x1F1A	RB2PPS	7:0						PPS[5:0]	
0x1F1B	RB3PPS	7:0						PPS[5:0]	
0x1F1C	RB4PPS	7:0						PPS[5:0]	
0x1F1D	RB5PPS	7:0						PPS[5:0]	
0x1F1E	RB6PPS	7:0						PPS[5:0]	
0x1F1F	RB7PPS	7:0						PPS[5:0]	
0x1F20	RC0PPS	7:0						PPS[5:0]	
0x1F21	RC1PPS	7:0						PPS[5:0]	
0x1F22	RC2PPS	7:0						PPS[5:0]	
0x1F23	RC3PPS	7:0						PPS[5:0]	
0x1F24	RC4PPS	7:0						PPS[5:0]	
0x1F25	RC5PPS	7:0						PPS[5:0]	
0x1F26	RC6PPS	7:0						PPS[5:0]	
0x1F27	RC7PPS	7:0						PPS[5:0]	

**15.9 Register Definitions: PPS Input and Output Selection**

### 15.9.1 Peripheral xxx Input Selection

**Name:** xxxPPS



**Important:** The Reset value of this register is determined by the device default for each peripheral.  
Refer to the [input selection table](#) for a list of available ports and default pin locations.

	7	6	5	4	3	2	1	0
				PORT[1:0]		PIN[2:0]		
Access				R/W	R/W	R/W	R/W	R/W
Reset				g	g	g	g	g

**Bits 4:3 – PORT[1:0]** Peripheral xxx Input PORT Selection bits

See the [input selection table](#) for a list of available ports and default pin locations.

Value	Description
10	PORTC
01	PORTB
00	PORTA

**Bits 2:0 – PIN[2:0]** Peripheral xxx Input Pin Selection bits

Value	Description
111	Peripheral input is from PORTx Pin 7 (Rx7)
110	Peripheral input is from PORTx Pin 6 (Rx6)
101	Peripheral input is from PORTx Pin 5 (Rx5)
100	Peripheral input is from PORTx Pin 4 (Rx4)
011	Peripheral input is from PORTx Pin 3 (Rx3)
010	Peripheral input is from PORTx Pin 2 (Rx2)
001	Peripheral input is from PORTx Pin 1 (Rx1)
000	Peripheral input is from PORTx Pin 0 (Rx0)

**15.9.2 Pin Rxy Output Source Selection Register**

**Name:** RxyPPS



**Important:** See [15.8 Register Summary - PPS](#) for the address offset of each individual register.

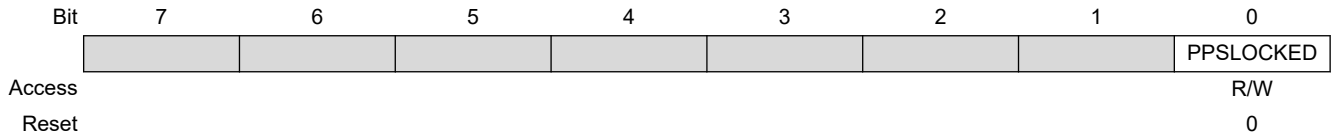
	7	6	5	4	3	2	1	0
			RxyPPS[5:0]					
Access			R/W	R/W	R/W	R/W	R/W	R/W
Reset			0	0	0	0	0	0

**Bits 5:0 – RxyPPS[5:0]** Pin Rxy Output Source Selection bits  
 See [output source selection table](#) for source codes.



**15.9.3 PPS Lock Register**

**Name:** PPSLOCK  
**Address:** 0x1E8F



**Bit 0 – PPSLOCKED** PPS Locked bit

Value	Description
1	PPS is locked. PPS selections can not be changed.
0	PPS is not locked. PPS selections can be changed.

## 16. (PMD) Peripheral Module Disable

This module provides the ability to selectively enable or disable a peripheral. Disabling a peripheral places it in its lowest possible power state. The user can disable unused modules to reduce the overall power consumption.

The PIC16(L)F18455/56 devices address this requirement by allowing peripheral modules to be selectively enabled or disabled. Disabling a peripheral places it in the lowest possible power mode.



**Important:** All modules are ON by default following any system Reset.

---

### 16.1 Disabling a Module

A peripheral can be disabled by setting the corresponding peripheral disable bit in the [PMDx](#) register. Disabling a module has the following effects:

- The module is held in Reset and does not function.
- All the SFRs pertaining to that peripheral become “unimplemented”
  - Writing is disabled
  - Reading returns 0x00
- Module outputs are disabled

#### Related Links

[15.9.3 PPSLOCK](#)

### 16.2 Enabling a Module

Clearing the corresponding module disable bit in the [PMDx](#) register, re-enables the module and the SFRs will reflect the Power-on Reset values.



**Important:** There should be no reads/writes to the module SFRs for at least two instruction cycles after it has been re-enabled.

---

### 16.3 System Clock Disable

Setting SYSCMD disables the system clock ( $F_{OSC}$ ) distribution network to the peripherals. Not all peripherals make use of SYSCLOCK, so not all peripherals are affected. Refer to the specific peripheral description to see if it will be affected by this bit.

#### Related Links

[16.5.1 PMD0](#)

## 16.4 Register Summary - PMD

Address	Name	Bit Pos.								
0x0796	<a href="#">PMD0</a>	7:0	SYSCMD	FVRMD				NVMMD	CLKRMD	IOCMD
0x0797	<a href="#">PMD1</a>	7:0		TMR6MD	TMR5MD	TMR4MD	TMR3MD	TMR2MD	TMR1MD	TMR0MD
0x0798	<a href="#">PMD2</a>	7:0	NCO1MD							
0x0799	<a href="#">PMD3</a>	7:0		DAC1MD	ADCMD			C2MD	C1MD	ZCDMD
0x079A	<a href="#">PMD4</a>	7:0		PWM7MD	PWM6MD	CCP5MD	CCP4MD	CCP3MD	CCP2MD	CCP1MD
0x079B	<a href="#">PMD5</a>	7:0	CWG3MD	CWG2MD	CWG1MD					
0x079C	<a href="#">PMD6</a>	7:0			UART2MD	UART1MD			MSSP2MD	MSSP1MD
0x079D	<a href="#">PMD7</a>	7:0		SMT2MD	SMT1MD	CLC4MD	CLC3MD	CLC2MD	CLC1MD	DSM1MD

## 16.5 Register Definitions: Peripheral Module Disable

**16.5.1 PMD0**

**Name:** PMD0  
**Address:** 0x796

PMD Control Register 0

Bit	7	6	5	4	3	2	1	0
	SYSCMD	FVRMD				NVMMD	CLKRMD	IOCMD
Access	R/W	R/W				R/W	R/W	R/W
Reset	0	0				0	0	0

**Bit 7 – SYSCMD** Disable Peripheral System Clock Network bit  
Disables the System clock network

Value	Description
1	System clock network disabled ( $F_{OSC}$ )
0	System clock network enabled

**Bit 6 – FVRMD** Disable Fixed Voltage Reference bit

Value	Description
1	FVR module disabled
0	FVR module enabled

**Bit 2 – NVMMD** NVM Module Disable bit<sup>(1)</sup>  
Disables the NVM module

Value	Description
1	All Memory reading and writing is disabled; NVMCON registers cannot be written; FSR access to these locations returns zero.
0	NVM module enabled

**Bit 1 – CLKRMD** Disable Clock Reference bit

Value	Description
1	CLKR module disabled
0	CLKR module enabled

**Bit 0 – IOCMD** Disable Interrupt-on-Change bit, All Ports

Value	Description
1	IOC module(s) disabled
0	IOC module(s) enabled

**Note:**

1. When enabling NVM, a delay of up to 1  $\mu$ s may be required before accessing data.

**Related Links**

[16.3 System Clock Disable](#)

**16.5.2 PMD1**

**Name:** PMD1  
**Address:** 0x797

PMD Control Register 1

Bit	7	6	5	4	3	2	1	0
		TMR6MD	TMR5MD	TMR4MD	TMR3MD	TMR2MD	TMR1MD	TMR0MD
Access		R/W	R/W	R/W	R/W	R/W	R/W	R/W
Reset		0	0	0	0	0	0	0

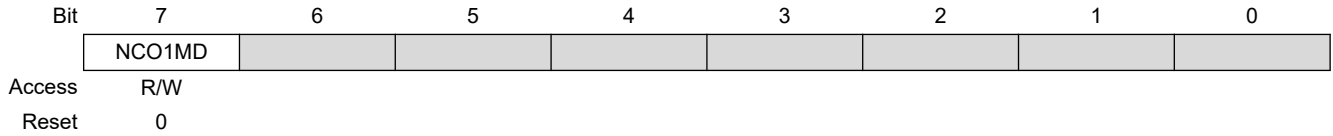
**Bits 0, 1, 2, 3, 4, 5, 6 – TMRnMD** Disable Timer n bit

Value	Description
1	TMRn module disabled
0	TMRn module enabled

**16.5.3 PMD2**

**Name:** PMD2  
**Address:** 0x798

PMD Control Register 2



**Bit 7 – NCO1MD** Disable Numerically Control Oscillator bit

Value	Description
1	NCO1 module disabled
0	NCO1 module enabled

**16.5.4 PMD3**

**Name:** PMD3  
**Address:** 0x799

PMD Control Register 3

Bit	7	6	5	4	3	2	1	0
		DAC1MD	ADCMD			C2MD	C1MD	ZCDMD
Access		R/W	R/W			R/W	R/W	R/W
Reset		0	0			0	0	0

**Bit 6 – DAC1MD** Disable DAC1 bit

Value	Description
1	DAC module disabled
0	DAC module enabled

**Bit 5 – ADCMD** Disable ADC bit

Value	Description
1	ADC module disabled
0	ADC module enabled

**Bit 2 – C2MD** Disable Comparator C2 bit

Value	Description
1	C2 module disabled
0	C2 module enabled

**Bit 1 – C1MD** Disable Comparator C1 bit

Value	Description
1	C1 module disabled
0	C1 module enabled

**Bit 0 – ZCDMD** Disable Zero-Cross Detect module bit

Value	Description
1	ZCD module disabled
0	ZCD module enabled

**16.5.5 PMD4**

**Name:** PMD4  
**Address:** 0x79A

PMD Control Register 4

Bit	7	6	5	4	3	2	1	0
		PWM7MD	PWM6MD	CCP5MD	CCP4MD	CCP3MD	CCP2MD	CCP1MD
Access		R/W	R/W	R/W	R/W	R/W	R/W	R/W
Reset		0	0	0	0	0	0	0

**Bit 6 – PWM7MD** Disable Pulse-Width Modulator PWM7 bit

Value	Description
1	PWM7 module disabled
0	PWM7 module enabled

**Bit 5 – PWM6MD** Disable Pulse-Width Modulator PWM6 bit

Value	Description
1	PWM6 module disabled
0	PWM6 module enabled

**Bit 4 – CCP5MD** Disable Pulse-Width Modulator CCP5 bit

Value	Description
1	CCP5 module disabled
0	CCP5 module enabled

**Bit 3 – CCP4MD** Disable Pulse-Width Modulator CCP4 bit

Value	Description
1	CCP4 module disabled
0	CCP4 module enabled

**Bit 2 – CCP3MD** Disable Pulse-Width Modulator CCP3 bit

Value	Description
1	CCP3 module disabled
0	CCP3 module enabled

**Bit 1 – CCP2MD** Disable Pulse-Width Modulator CCP2 bit

Value	Description
1	CCP2 module disabled
0	CCP2 module enabled

**Bit 0 – CCP1MD** Disable Pulse-Width Modulator CCP1 bit



# PIC16(L)F18455/56

## (PMD) Peripheral Module Disable

Value	Description
1	CCP1 module disabled
	CCP1 module enabled

**16.5.6 PMD5**

**Name:** PMD5  
**Address:** 0x79B

PMD Control Register 5

Bit	7	6	5	4	3	2	1	0
	CWG3MD	CWG2MD	CWG1MD					
Access	R/W	R/W	R/W					
Reset	0	0	0					

**Bit 7 – CWG3MD** Disable CWG3 bit

Value	Description
1	CWG3 module disabled
0	CWG3 module enabled

**Bit 6 – CWG2MD** Disable CWG2 bit

Value	Description
1	CWG2 module disabled
0	CWG2 module enabled

**Bit 5 – CWG1MD** Disable CWG1 bit

Value	Description
1	CWG1 module disabled
0	CWG1 module enabled

**16.5.7 PMD6**

**Name:** PMD6  
**Address:** 0x79C

PMD Control Register 6

Bit	7	6	5	4	3	2	1	0
			UART2MD	UART1MD			MSSP2MD	MSSP1MD
Access			R/W	R/W			R/W	R/W
Reset			0	0			0	0

**Bit 5 – UART2MD** Disable EUSART2 bit

Value	Description
1	EUSART2 module disabled
0	EUSART2 module enabled

**Bit 4 – UART1MD** Disable EUSART1 bit

Value	Description
1	EUSART1 module disabled
0	EUSART1 module enabled

**Bit 1 – MSSP2MD** Disable MSSP2 bit

Value	Description
1	MSSP2 module disabled
0	MSSP2 module enabled

**Bit 0 – MSSP1MD** Disable MSSP1 bit

Value	Description
1	MSSP1 module disabled
0	MSSP1 module enabled

**16.5.8 PMD7**

**Name:** PMD7  
**Address:** 0x79D

PMD Control Register 7

Bit	7	6	5	4	3	2	1	0
		SMT2MD	SMT1MD	CLC4MD	CLC3MD	CLC2MD	CLC1MD	DSM1MD
Access		R/W	R/W	R/W	R/W	R/W	R/W	R/W
Reset		0	0	0	0	0	0	0

**Bit 6 – SMT2MD** Disable Signal Measurement Timer 2 bit

Value	Description
1	SMT2 module disabled
0	SMT2 module enabled

**Bit 5 – SMT1MD** Disable Signal Measurement Timer 1 bit

Value	Description
1	SMT1 module disabled
0	SMT1 module enabled

**Bits 1, 2, 3, 4 – CLCnMD** Disable CLCn bit

Value	Description
1	CLCn module disabled
0	CLCn module enabled

**Bit 0 – DSM1MD** Disable Data Signal Modulator 1 bit

Value	Description
1	DSM1 module disabled
0	DSM1 module enabled

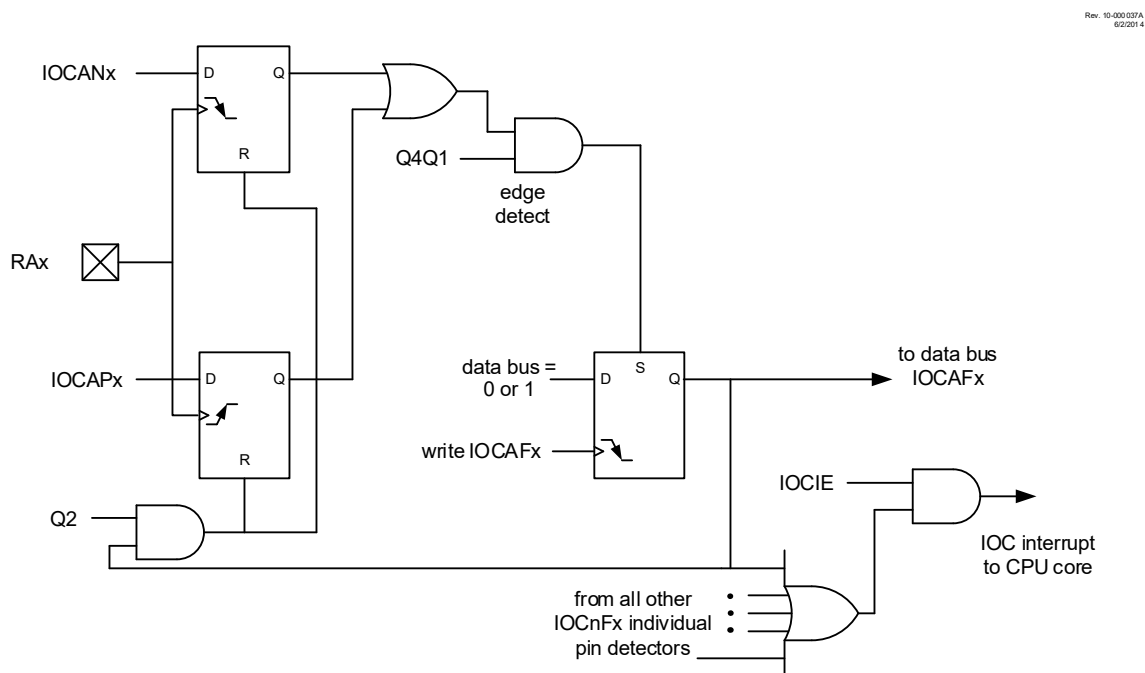
## 17. Interrupt-on-Change

An interrupt can be generated by detecting a signal that has either a rising edge or a falling edge. Any individual pin, or combination of pins, can be configured to generate an interrupt. The interrupt-on-change module has the following features:

- Interrupt-on-Change enable (Master Switch)
- Individual pin configuration
- Rising and falling edge detection
- Individual pin interrupt flags

The following figure is a block diagram of the IOC module.

**Figure 17-1. Interrupt-on-Change Block Diagram (PORTA Example)**



**Note:** See link below for BOR Active Conditions.

### Related Links

[8.2.3 BOR Controlled by Software](#)

### 17.1 Enabling the Module

To allow individual port pins to generate an interrupt, the IOCIE bit of the PIE0 register must be set. If the IOCIE bit is disabled, the edge detection on the pin will still occur, but an interrupt will not be generated.

### Related Links

[10.7.2 PIE0](#)

## 17.2 Individual Pin Configuration

For each port pin, a rising edge detector and a falling edge detector are present. To enable a pin to detect a rising edge, the associated bit of the IOCxP register is set. To enable a pin to detect a falling edge, the associated bit of the IOCxN register is set.

A pin can be configured to detect rising and falling edges simultaneously by setting both associated bits of the IOCxP and IOCxN registers, respectively.

## 17.3 Interrupt Flags

The bits located in the IOCxF registers are status flags that correspond to the interrupt-on-change pins of each port. If an expected edge is detected on an appropriately enabled pin, then the status flag for that pin will be set, and an interrupt will be generated if the IOCIE bit is set. The IOCIF bit of the PIR0 register reflects the status of all IOCxF bits.

### Related Links

[10.7.11 PIR0](#)

### 17.3.1 Clearing Interrupt Flags

The individual status flags, (IOCxF register bits), can be cleared by resetting them to zero. If another edge is detected during this clearing operation, the associated status flag will be set at the end of the sequence, regardless of the value actually being written.

In order to ensure that no detected edge is lost while clearing flags, only **AND** operations masking out known changed bits should be performed. The following sequence is an example of what should be performed.

#### Example 17-1. Clearing Interrupt Flags (PORTA Example)

```
MOVLW    0xff
XORWF    IOCAF, W
ANDWF    IOCAF, F
```

## 17.4 Operation in Sleep

The interrupt-on-change interrupt sequence will wake the device from Sleep mode, if the IOCIE bit is set.

If an edge is detected while in Sleep mode, the IOCxF register will be updated prior to the first instruction executed out of Sleep.

## 17.5 Register Summary - Interrupt-on-Change

Address	Name	Bit Pos.								
0x1F3D	IOCAP	7:0	IOCAP7	IOCAP6	IOCAP5	IOCAP4	IOCAP3	IOCAP2	IOCAP1	IOCAP0
0x1F3E	IOCAN	7:0	IOCAN7	IOCAN6	IOCAN5	IOCAN4	IOCAN3	IOCAN2	IOCAN1	IOCAN0
0x1F3F	IOCAF	7:0	IOCAF7	IOCAF6	IOCAF5	IOCAF4	IOCAF3	IOCAF2	IOCAF1	IOCAF0
0x1F40 ... 0x1F47	Reserved									
0x1F48	IOCBP	7:0	IOCBP7	IOCBP6	IOCBP5	IOCBP4	IOCBP3	IOCBP2	IOCBP1	IOCBP0
0x1F49	IOCBN	7:0	IOCBN7	IOCBN6	IOCBN5	IOCBN4	IOCBN3	IOCBN2	IOCBN1	IOCBN0
0x1F4A	IOCBF	7:0	IOCBF7	IOCBF6	IOCBF5	IOCBF4	IOCBF3	IOCBF2	IOCBF1	IOCBF0
0x1F4B ... 0x1F52	Reserved									
0x1F53	IOCCP	7:0	IOCCP7	IOCCP6	IOCCP5	IOCCP4	IOCCP3	IOCCP2	IOCCP1	IOCCP0
0x1F54	IOCCN	7:0	IOCCN7	IOCCN6	IOCCN5	IOCCN4	IOCCN3	IOCCN2	IOCCN1	IOCCN0
0x1F55	IOCCF	7:0	IOCCF7	IOCCF6	IOCCF5	IOCCF4	IOCCF3	IOCCF2	IOCCF1	IOCCF0
0x1F56 ... 0x1F68	Reserved									
0x1F69	IOCEP	7:0					IOCEP3			
0x1F6A	IOCEN	7:0					IOCEN3			
0x1F6B	IOCEF	7:0					IOCEF3			

## 17.6 Register Definitions: Interrupt-on-Change Control

**17.6.1 IOCAF**

**Name:** IOCAF  
**Address:** 0x1F3F

PORTA Interrupt-on-Change Flag Register Example

Bit	7	6	5	4	3	2	1	0
	IOCAF7	IOCAF6	IOCAF5	IOCAF4	IOCAF3	IOCAF2	IOCAF1	IOCAF0
Access	R/W/HS	R/W/HS	R/W/HS	R/W/HS	R/W/HS	R/W/HS	R/W/HS	R/W/HS
Reset	0	0	0	0	0	0	0	0

**Bits 0, 1, 2, 3, 4, 5, 6, 7 – IOCAF<sub>n</sub>** Interrupt-on-Change Flag bits

Value	Condition	Description
1	IOCAP[n]=1	A positive edge was detected on the RA[n] pin
1	IOCAN[n]=1	A negative edge was detected on the RA[n] pin
0	IOCAP[n]=x and IOCAN[n]=x	No change was detected, or the user cleared the detected change



**17.6.2 IOCBF**

**Name:** IOCBF  
**Address:** 0x1F4A

PORTB Interrupt-on-Change Flag Register Example

Bit	7	6	5	4	3	2	1	0
	IOCBF7	IOCBF6	IOCBF5	IOCBF4	IOCBF3	IOCBF2	IOCBF1	IOCBF0
Access	R/W/HS	R/W/HS	R/W/HS	R/W/HS	R/W/HS	R/W/HS	R/W/HS	R/W/HS
Reset	0	0	0	0	0	0	0	0

**Bits 0, 1, 2, 3, 4, 5, 6, 7 – IOCBFn** Interrupt-on-Change Flag bits

Value	Condition	Description
1	IOCBP[n]=1	A positive edge was detected on the RB[n] pin
1	IOCBN[n]=1	A negative edge was detected on the RB[n] pin
0	IOCBP[n]=x and IOCBN[n]=x	No change was detected, or the user cleared the detected change

**17.6.3 IOCCF**

**Name:** IOCCF  
**Address:** 0x1F55

PORTC Interrupt-on-Change Flag Register

Bit	7	6	5	4	3	2	1	0
	IOCCF7	IOCCF6	IOCCF5	IOCCF4	IOCCF3	IOCCF2	IOCCF1	IOCCF0
Access	R/W/HS	R/W/HS	R/W/HS	R/W/HS	R/W/HS	R/W/HS	R/W/HS	R/W/HS
Reset	0	0	0	0	0	0	0	0

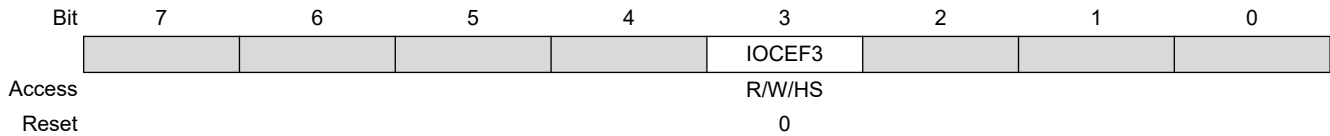
**Bits 0, 1, 2, 3, 4, 5, 6, 7 – IOCCFn** Interrupt-on-Change Flag bits

Value	Condition	Description
1	IOCCP[n]=1	A positive edge was detected on the RC[n] pin
1	IOCCN[n]=1	A negative edge was detected on the RC[n] pin
0	IOCCP[n]=x and IOCCN[n]=x	No change was detected, or the user cleared the detected change

17.6.4 IOCEF

**Name:** IOCEF  
**Address:** 0x1F6B

PORTE Interrupt-on-Change Flag Register



**Bit 3 – IOCEF3** PORTE Interrupt-on-Change Flag bits<sup>(1)</sup>

Value	Condition	Description
1	IOCEP[n]=1	A positive edge was detected on the RE[n] pin
1	IOCEN[n]=1	A negative edge was detected on the RE[n] pin
0	IOCEP[n]=x and IOCEN[n]=x	No change was detected, or the user cleared the detected change

**Note:**

1. If MCLRE = 1 or LVP = 1, RE3 port functionality is disabled and IOC on RE3 is not available.

**17.6.5 IOCAN**

**Name:** IOCAN  
**Address:** 0x1F3E

Interrupt-on-Change Negative Edge Register Example

Bit	7	6	5	4	3	2	1	0
	IOCAN7	IOCAN6	IOCAN5	IOCAN4	IOCAN3	IOCAN2	IOCAN1	IOCAN0
Access	R/W	R/W	R/W	R/W	R/W	R/W	R/W	R/W
Reset	0	0	0	0	0	0	0	0

**Bits 0, 1, 2, 3, 4, 5, 6, 7 – IOCANn** Interrupt-on-Change Negative Edge Enable bits

Value	Description
1	Interrupt-on-Change enabled on the IOCA pin for a negative-going edge. Associated Status bit and interrupt flag will be set upon detecting an edge.
0	Interrupt-on-Change disabled for the associated pin

**17.6.6 IOCBN**

**Name:** IOCBN  
**Address:** 0x1F49

Interrupt-on-Change Negative Edge Register Example

Bit	7	6	5	4	3	2	1	0
	IOCBN7	IOCBN6	IOCBN5	IOCBN4	IOCBN3	IOCBN2	IOCBN1	IOCBN0
Access	R/W	R/W	R/W	R/W	R/W	R/W	R/W	R/W
Reset	0	0	0	0	0	0	0	0

**Bits 0, 1, 2, 3, 4, 5, 6, 7 – IOCBNn** Interrupt-on-Change Negative Edge Enable bits

Value	Description
1	Interrupt-on-Change enabled on the IOCA pin for a negative-going edge. Associated Status bit and interrupt flag will be set upon detecting an edge.
0	Interrupt-on-Change disabled for the associated pin.

**17.6.7 IOCCN**

**Name:** IOCCN  
**Address:** 0x1F54

Interrupt-on-Change Negative Edge Register Example

Bit	7	6	5	4	3	2	1	0
	IOCCN7	IOCCN6	IOCCN5	IOCCN4	IOCCN3	IOCCN2	IOCCN1	IOCCN0
Access	R/W	R/W	R/W	R/W	R/W	R/W	R/W	R/W
Reset	0	0	0	0	0	0	0	0

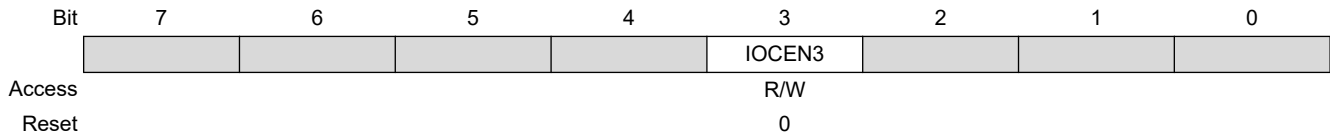
**Bits 0, 1, 2, 3, 4, 5, 6, 7 – IOCCNn** Interrupt-on-Change Negative Edge Enable bits

Value	Description
1	Interrupt-on-Change enabled on the IOCA pin for a negative-going edge. Associated Status bit and interrupt flag will be set upon detecting an edge.
0	Interrupt-on-Change disabled for the associated pin.

**17.6.8 IOCN**

**Name:** IOCN  
**Address:** 0x1F6A

Interrupt-on-Change Negative Edge Register Example



**Bit 3 – IOCN3** Interrupt-on-Change Negative Edge Enable bits<sup>(1)</sup>

Value	Description
1	Interrupt-on-Change enabled on the IOCA pin for a negative-going edge. Associated Status bit and interrupt flag will be set upon detecting an edge.
0	Interrupt-on-Change disabled for the associated pin

**Note:**

1. If MCLRE = 1 or LVP = 1, RE3 port functionality is disabled and IOC on RE3 is not available.

**17.6.9 IOCAP**

**Name:** IOCAP  
**Address:** 0x1F3D

Interrupt-on-Change Positive Edge Register

Bit	7	6	5	4	3	2	1	0
	IOCAP7	IOCAP6	IOCAP5	IOCAP4	IOCAP3	IOCAP2	IOCAP1	IOCAP0
Access	R/W	R/W	R/W	R/W	R/W	R/W	R/W	R/W
Reset	0	0	0	0	0	0	0	0

**Bits 0, 1, 2, 3, 4, 5, 6, 7 – IOCAPn** Interrupt-on-Change Positive Edge Enable bits

Value	Description
1	Interrupt-on-Change enabled on the IOCA pin for a positive-going edge. Associated Status bit and interrupt flag will be set upon detecting an edge.
0	Interrupt-on-Change disabled for the associated pin.



**17.6.10 IOCBP**

**Name:** IOCBP  
**Address:** 0x1F48

Interrupt-on-Change Positive Edge Register

Bit	7	6	5	4	3	2	1	0
	IOCBP7	IOCBP6	IOCBP5	IOCBP4	IOCBP3	IOCBP2	IOCBP1	IOCBP0
Access	R/W	R/W	R/W	R/W	R/W	R/W	R/W	R/W
Reset	0	0	0	0	0	0	0	0

**Bits 0, 1, 2, 3, 4, 5, 6, 7 – IOCBPn** Interrupt-on-Change Positive Edge Enable bits

Value	Description
1	Interrupt-on-Change enabled on the IOCB pin for a positive-going edge. Associated Status bit and interrupt flag will be set upon detecting an edge.
0	Interrupt-on-Change disabled for the associated pin.

**17.6.11 IOCCP**

**Name:** IOCCP  
**Address:** 0x1F53

Interrupt-on-Change Positive Edge Register

Bit	7	6	5	4	3	2	1	0
	IOCCP7	IOCCP6	IOCCP5	IOCCP4	IOCCP3	IOCCP2	IOCCP1	IOCCP0
Access	R/W	R/W	R/W	R/W	R/W	R/W	R/W	R/W
Reset	0	0	0	0	0	0	0	0

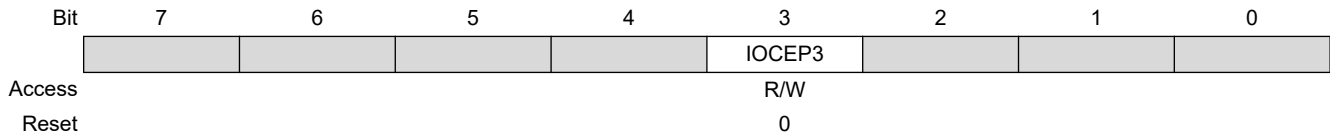
**Bits 0, 1, 2, 3, 4, 5, 6, 7 – IOCCPn** Interrupt-on-Change Positive Edge Enable bits

Value	Description
1	Interrupt-on-Change enabled on the IOCC pin for a positive-going edge. Associated Status bit and interrupt flag will be set upon detecting an edge.
0	Interrupt-on-Change disabled for the associated pin.

**17.6.12 IOCEP**

**Name:** IOCEP  
**Address:** 0x1F69

Interrupt-on-Change Positive Edge Register



**Bit 3 – IOCEP3** Interrupt-on-Change Positive Edge Enable bit<sup>(1)</sup>

Value	Description
1	Interrupt-on-Change enabled on the IOCE pin for a positive-going edge. Associated Status bit and interrupt flag will be set upon detecting an edge.
0	Interrupt-on-Change disabled for the associated pin.

**Note:**

1. If MCLRE = 1 or LVP = 1, RE3 port functionality is disabled and IOC on RE3 is not available.

## 18. (FVR) Fixed Voltage Reference

The Fixed Voltage Reference (FVR) is a stable voltage reference, independent of  $V_{DD}$ , with the following selectable output levels:

- 1.024V
- 2.048V
- 4.096V

The output of the FVR can be configured to supply a reference voltage to the following:

- ADC input channel
- ADC positive reference
- Comparator input
- Digital-to-Analog Converter (DAC)

The FVR can be enabled by setting the FVREN bit of the FVRCON register.



**Important:** Fixed Voltage Reference output cannot exceed  $V_{DD}$ .

---

### Related Links

[18.4.1 FVRCON](#)

### 18.1 Independent Gain Amplifiers

The output of the FVR, which is connected to the ADC, Comparators, and DAC, is routed through two independent programmable gain amplifiers. Each amplifier can be programmed for a gain of 1x, 2x or 4x, to produce the three possible voltage levels.

The ADFVR<1:0> bits of the FVRCON register are used to enable and configure the gain amplifier settings for the reference supplied to the ADC module. Reference the ADC chapter for additional information.

The CDAFVR<1:0> bits of the FVRCON register are used to enable and configure the gain amplifier settings for the reference supplied to the DAC and comparator module.

### Related Links

[20. \(ADC2\) Analog-to-Digital Converter with Computation Module](#)

[23. \(CMP\) Comparator Module](#)

[21. \(DAC\) 5-Bit Digital-to-Analog Converter Module](#)

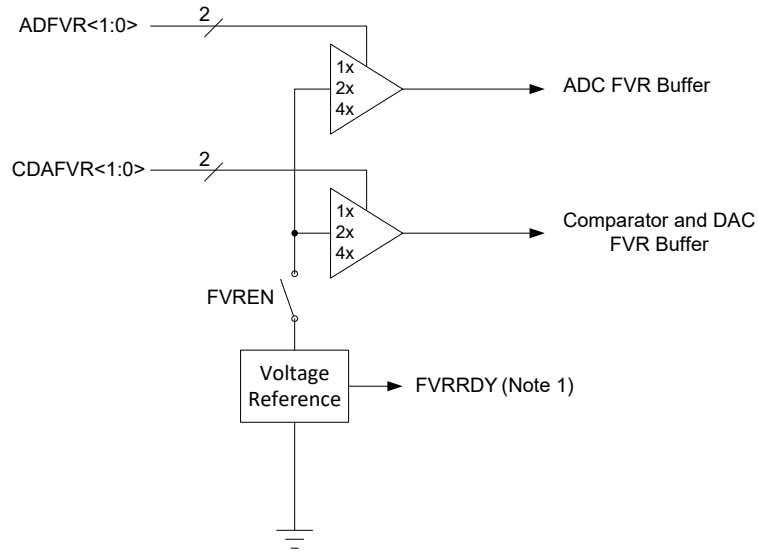
### 18.2 FVR Stabilization Period

When the Fixed Voltage Reference module is enabled, it requires time for the reference and amplifier circuits to stabilize. Once the circuits stabilize and are ready for use, the FVRRDY bit of the FVRCON register will be set.

FVRRDY is an indicator of the reference being ready.

Figure 18-1. Voltage Reference Block Diagram

Rev. 10-000053D  
9/18/2016



**Note:**

1. In the case of an F device, or a device on which the BOR is enabled in the Configuration Word settings, then the FVRRDY bit will be high prior to setting FVREN as those modules require the reference voltage.

### 18.3 Register Summary - FVR

Address	Name	Bit Pos.							
0x090C	<a href="#">FVRCON</a>	7:0	FVREN	FVRRDY	TSEN	TSRNG	CDAFVR[1:0]		ADFVR[1:0]

### 18.4 Register Definitions: FVR Control

### 18.4.1 FVRCON

**Name:** FVRCON  
**Address:** 0x90C

Fixed Voltage Reference Control Register

Bit	7	6	5	4	3	2	1	0
	FVREN	FVRRDY	TSEN	TSRNG	CDAFVR[1:0]		ADFVR[1:0]	
Access	R/W	R	R/W	R/W	R/W	R/W	R/W	R/W
Reset	0	q	0	0	0	0	0	0

**Bit 7 – FVREN** Fixed Voltage Reference Enable bit

Value	Description
1	Fixed Voltage Reference is enabled
0	Fixed Voltage Reference is disabled

**Bit 6 – FVRRDY** Fixed Voltage Reference Ready Flag bit

Value	Description
1	Fixed Voltage Reference output is ready for use
0	Fixed Voltage Reference output is not ready or not enabled

**Bit 5 – TSEN**

Temperature Indicator Enable bit<sup>(2)</sup>

Value	Description
1	Temperature Indicator is enabled
0	Temperature Indicator is disabled

**Bit 4 – TSRNG**

Temperature Indicator Range Selection bit<sup>(2)</sup>

Value	Description
1	$V_{OUT} = V_{DD} - 4V_t$ (High Range)
0	$V_{OUT} = V_{DD} - 2V_t$ (Low Range)

**Bits 3:2 – CDAFVR[1:0]** Comparator FVR Buffer Gain Selection bits

Value	Description
11	Comparator FVR Buffer Gain is 4x, (4.096V) <sup>(1)</sup>
10	Comparator FVR Buffer Gain is 2x, (2.048V) <sup>(1)</sup>
01	Comparator FVR Buffer Gain is 1x, (1.024V)
00	Comparator FVR Buffer is off

**Bits 1:0 – ADFVR[1:0]** ADC FVR Buffer Gain Selection bit

Value	Description
11	ADC FVR Buffer Gain is 4x, (4.096V) <sup>(1)</sup>
10	ADC FVR Buffer Gain is 2x, (2.048V) <sup>(1)</sup>

# PIC16(L)F18455/56

## (FVR) Fixed Voltage Reference

Value	Description
01	ADC FVR Buffer Gain is 1x, (1.024V)
00	ADC FVR Buffer is off

**Note:**

1. Fixed Voltage Reference output cannot exceed  $V_{DD}$ .
2. See *Temperature Indicator Module* section for additional information.

**Related Links**

[19. Temperature Indicator Module](#)



## 19. Temperature Indicator Module

This family of devices is equipped with a temperature circuit designed to measure the operating temperature of the silicon die. The main purpose of the temperature indicator module is to provide a temperature-dependent voltage that can be measured by the Analog-to-Digital Converter.

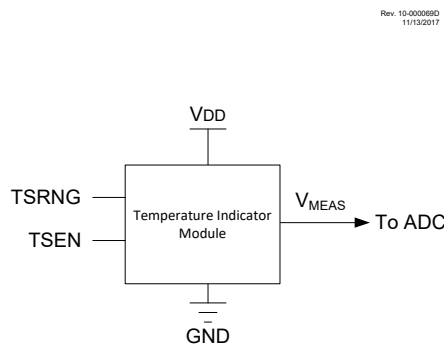
The circuit's range of operating temperature falls between  $-40^{\circ}\text{C}$  and  $+125^{\circ}\text{C}$ . The circuit may be used as a temperature threshold detector or a more accurate temperature indicator, depending on the level of calibration performed. A one-point calibration allows the circuit to indicate a temperature closely surrounding that point. A two-point calibration allows the circuit to sense the entire range of temperature more accurately.

### 19.1 Module Operation

The temperature indicator module consists of a temperature-sensing circuit that provides a voltage to the device ADC. The analog voltage output,  $V_{\text{MEAS}}$ , varies inversely to the device temperature. The output of the temperature indicator is referred to as  $V_{\text{MEAS}}$ .

The following figure shows a simplified block diagram of the temperature indicator module.

**Figure 19-1. Temperature Indicator Module Block Diagram**



The output of the circuit is measured using the internal Analog-to-Digital Converter. A channel is reserved for the temperature circuit output. Refer to the ADC link below for detailed information.

The ON/OFF bit for the module is located in the FVRCON register. The circuit is enabled by setting the TSEN bit of the FVRCON register. When the module is disabled, the circuit draws no current. Refer to the FVR link below for more information.

The circuit operates in either High or Low range. Refer to the “*Temperature Indicator Range*” for more details on the range settings.

#### Related Links

[18. \(FVR\) Fixed Voltage Reference](#)

[19.3 Temperature Indicator Range](#)

[20. \(ADC2\) Analog-to-Digital Converter with Computation Module](#)

## 19.2 Minimum Operating $V_{DD}$

When the temperature circuit is operated in low range, the device may be operated at any operating voltage that is within specifications. When the temperature circuit is operated in high range, the device operating voltage,  $V_{DD}$ , must be high enough to ensure that the temperature circuit is correctly biased.

The following table shows the recommended minimum  $V_{DD}$  vs. range setting.

**Table 19-1. Recommended  $V_{DD}$  vs. Range**

Min. $V_{DD}$ , TSRNG = 1 (High Range)	Min. $V_{DD}$ , TSRNG = 0 (Low Range)
$\geq 2.5V$	$\geq 1.8V$

## 19.3 Temperature Indicator Range

The temperature indicator circuit operates in either High or Low range. The High range, selected by setting the TSRNG bit of the FVRCON register, provides a wider output voltage. This provides more resolution over the temperature range. High range requires a higher-bias voltage to operate and thus, a higher  $V_{DD}$  is needed. The Low range is selected by clearing the TSRNG bit of the FVRCON register. The Low range generates a lower sensor voltage and thus, a lower  $V_{DD}$  voltage is needed to operate the circuit.

The output voltage of the sensor is the highest value at  $-40^{\circ}C$  and the lowest value at  $+125^{\circ}C$ .

- **High Range:** The High range is used in applications with the reference for the ADC,  $V_{REF} = 2.048V$ . This range may not be suitable for battery-powered applications. The ADC reading (in counts) at  $90^{\circ}C$  for the high range setting is stored in the [DIA Table](#) as parameter TSHR2.
- **Low Range:** This mode is useful in applications in which the  $V_{DD}$  is too low for high-range operation. The  $V_{DD}$  in this mode can be as low as 1.8V.  $V_{DD}$  must, however, be at least 0.5V higher than the maximum sensor voltage depending on the expected low operating temperature. The ADC reading (in counts) at  $90^{\circ}C$  for the low range setting is stored in the [DIA Table](#) as parameter TSLR2.

## 19.4 Estimation of Temperature

This section describes the steps involved in estimating the die temperature,  $T_{MEAS}$ :

1. Obtain the ADC count value of the measured analog voltage: The analog output voltage,  $V_{MEAS}$  is converted to a digital count value by the Analog-to-Digital Converter (ADC) and is referred to as  $ADC_{MEAS}$ .
2. Obtain the ADC count value,  $ADC_{DIA}$  at  $90^{\circ}C$ , from the [DIA Table](#). This parameter is TSLR2 for the low range setting or TSHR2 for the high range setting of the temperature indicator module.
3. Obtain the output analog voltage (in mV) value of the Fixed Reference Voltage (FVR) for 2x setting, from the DIA table. This parameter is referred to as FVRA2X in the [DIA Table](#).
4. Obtain the value of the temperature indicator voltage sensitivity, parameter  $Mv$ , from the “*Electrical Specifications*” section .

The following equation provides an estimate of the die temperature based on the above parameters:

### Equation 19-1. Sensor Temperature

$$T_{MEAS} = 90 + \frac{(ADC_{MEAS} - ADC_{DIA}) \times FVRA2X}{(2^N - 1) \times Mv}$$

**Note:** Where:

$ADC_{MEAS}$  = ADC reading at temperature being estimated

$ADC_{DIA}$  = ADC reading stored in the DIA

FVRA2X = FVR value stored in the DIA for 2x setting

N = Resolution of the ADC

Mv = Temperature Indicator voltage sensitivity (mV/°C)

**Note:** It is recommended to take the average of ten measurements of  $ADC_{MEAS}$  to reduce noise and improve accuracy.

**Related Links**

[42.4.6 Temperature Indicator Requirements](#)

**19.4.1 Calibration**

**19.4.1.1 Higher-Order Calibration**

If the application requires more precise temperature measurement, additional calibrations steps will be necessary. For these applications, two-point or three-point calibration is recommended. An Application Note will be released in future that demonstrates higher-order calibration process. An Application Note will be released in future that demonstrates higher-order calibration process.

**19.4.2 Temperature Resolution**

The resolution of the ADC reading,  $M_a$  (°C/count), depends on both the ADC resolution N and the reference voltage used for conversion, as shown in the equation below. It is recommended to use the smallest  $V_{REF}$  value, such as the ADC FVR1 Output Voltage for 2x setting (FVRA2X) value from the [DIA Table](#).

**Related Links**

[42.4.11 Fixed Voltage Reference \(FVR\) Specifications](#)

**19.5 ADC Acquisition Time**

To ensure accurate temperature measurements, the user must wait a minimum of 25  $\mu$ s for the ADC value to settle, after the ADC input multiplexer is connected to the temperature indicator output, before the conversion is performed.

## 20. (ADC<sup>2</sup>) Analog-to-Digital Converter with Computation Module

The Analog-to-Digital Converter with Computation (ADC<sup>2</sup>) allows conversion of an analog input signal to a 12-bit binary representation of that signal. This device uses analog inputs, which are multiplexed into a single sample and hold circuit. The output of the sample and hold is connected to the input of the converter. The converter generates a 12-bit binary result via successive approximation and stores the conversion result into the ADC result registers (ADRESH:ADRESL register pair).

Additionally, the following features are provided within the ADC module:

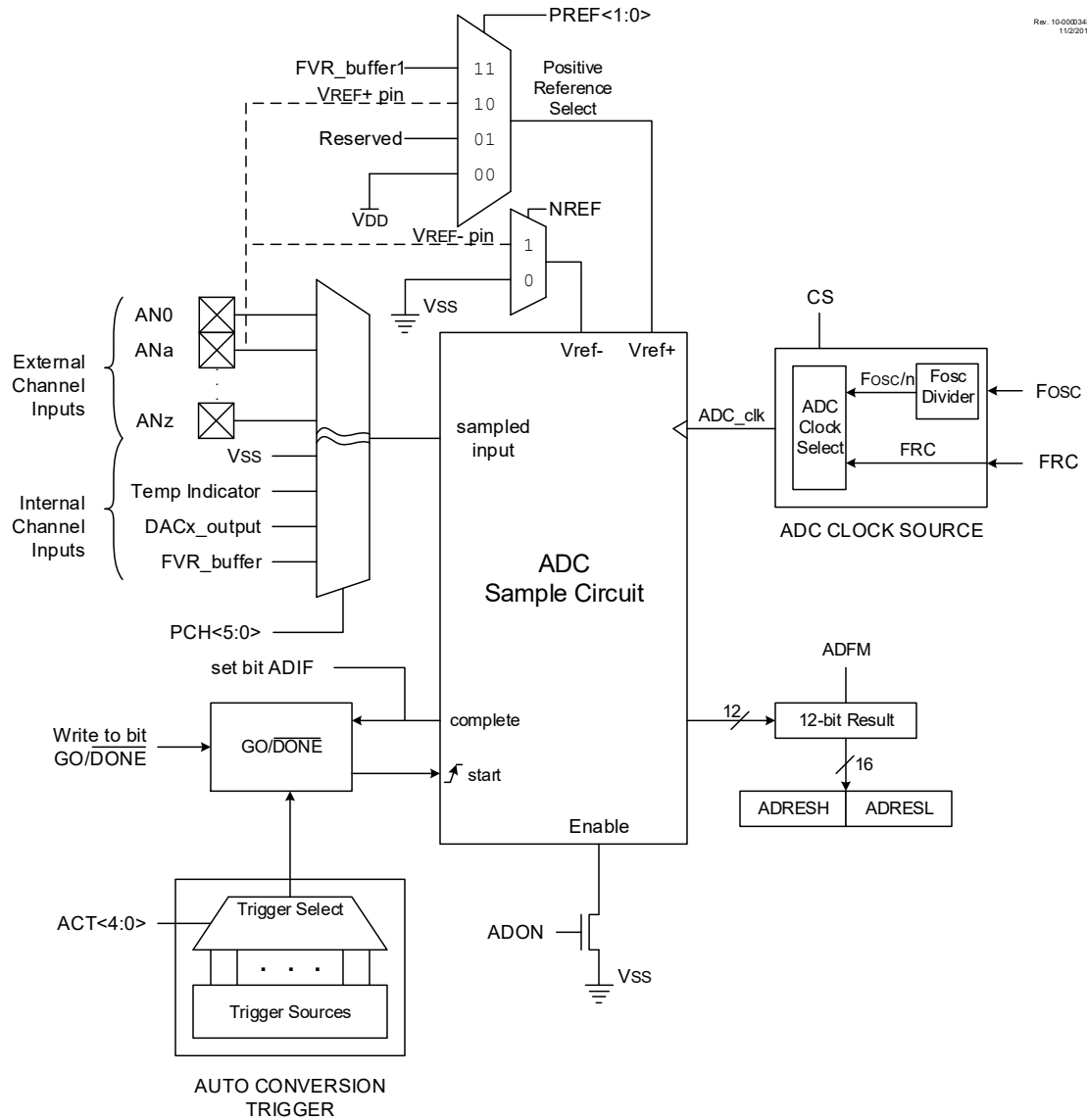
- 13-bit Acquisition Timer
- Hardware Capacitive Voltage Divider (CVD) Support:
  - 13-bit precharge timer
  - Adjustable sample and hold capacitor array
  - Guard ring digital output drive
- Automatic Repeat and Sequencing:
  - Automated double sample conversion for CVD
  - Two sets of result registers (Result and Previous result)
  - Auto-conversion trigger
  - Internal retrigger
- Computation Features:
  - Averaging and low-pass filter functions
  - Reference comparison
  - 2-level threshold comparison
  - Selectable interrupts

The figure below shows the block diagram of the ADC.

The ADC voltage reference is software selectable to be either internally generated or externally supplied.

The ADC can generate an interrupt upon completion of a conversion and upon threshold comparison. These interrupts can be used to wake-up the device from Sleep.

Figure 20-1. ADC<sup>2</sup> Block Diagram



## 20.1 ADC Configuration

When configuring and using the ADC the following functions must be considered:

- Port Configuration
- Channel Selection
- ADC Voltage Reference Selection
- ADC Conversion Clock Source
- Interrupt Control
- Result Formatting
- Conversion Trigger Selection
- ADC Acquisition Time

- ADC Precharge Time
- Additional Sample and Hold Capacitor
- Single/Double Sample Conversion
- Guard Ring Outputs

### 20.1.1 Port Configuration

The ADC can be used to convert both analog and digital signals. When converting analog signals, the I/O pin should be configured for analog by setting the associated TRIS and ANSEL bits. Refer to the "I/O Ports" section for more information.



**Important:** Analog voltages on any pin that is defined as a digital input may cause the input buffer to conduct excess current.

### Related Links

[14. I/O Ports](#)

### 20.1.2 Channel Selection

The ADPCH register determines which channel is connected to the sample and hold circuit.

When changing channels, a delay is required before starting the next conversion.

There are several channel selections available, as shown in the following table:

**Table 20-1. ADC Positive Input Channel Selections**

PCH	ADC Positive Channel Input
111111	Fixed Voltage Reference (FVR) 2
111110	Fixed Voltage Reference (FVR) 1
111101	DAC1 output
111100	Temperature Indicator
111011	AV <sub>SS</sub> (Analog Ground)
111010-011000	Reserved. No channel connected.
010111	RC7/ANC7
010110	RC6/ANC6
010101	RC5/ ANC5
010100	RC4/ ANC4
010011	RC3/ANC3
010010	RC2/ANC2
010001	RC1/ ANC1
010000	RC0/ANC0
001111	RB7/ANB7

PCH	ADC Positive Channel Input
001110	RB6/ANB6
001101	RB5/ANB5
001100	RB4/ ANB4
001011	RB3/ANB3
001010	RB2/ ANB2
001001	RB1/ ANB1
001000	RB0/ANB0
000111	RA7/ANA7
000110	RA6/ANA6
000101	RA5/ANA5
000100	RA4/ANA4
000011	RA3/ANA3
000010	RA2/ ANA2
000001	RA1/ ANA1
000000	RA0/ANA0

**Related Links**

- [20.2 ADC Operation](#)
- [18. \(FVR\) Fixed Voltage Reference](#)
- [19. Temperature Indicator Module](#)
- [21. \(DAC\) 5-Bit Digital-to-Analog Converter Module](#)

**20.1.3 ADC Voltage Reference**

The **PREF** bits provide control of the positive voltage reference. The positive voltage reference can be:

- $V_{REF+}$  pin
- $V_{DD}$
- FVR 1.024V
- FVR 2.048V
- FVR 4.096V

The **NREF** bit provides control of the negative voltage reference. The negative voltage reference can be:

- $V_{REF-}$  pin
- $V_{SS}$

**Related Links**

- [18. \(FVR\) Fixed Voltage Reference](#)
- [20.8.7 ADREF](#)

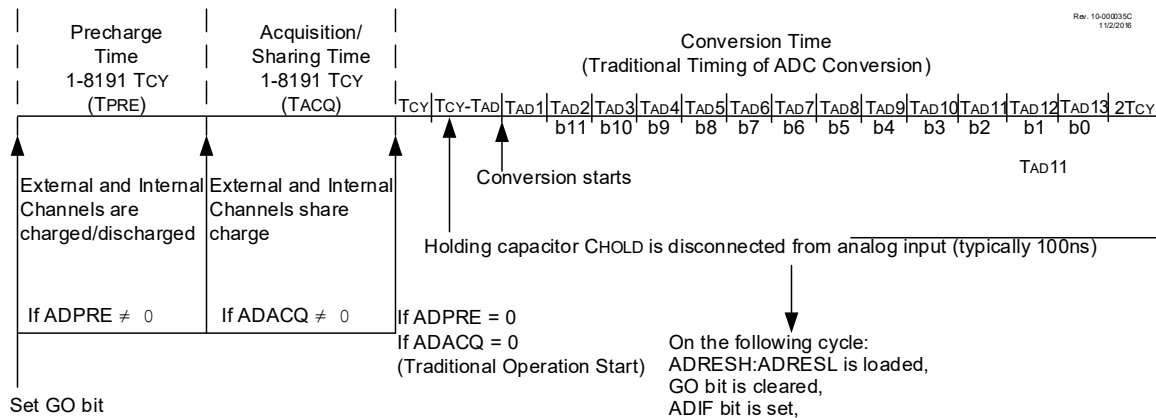
20.1.4 Conversion Clock

The source of the conversion clock is software selectable via the ADCLK register and the CS bit. If F<sub>OSC</sub> is selected as the ADC clock, there is a prescaler available to divide the clock so that it meets the ADC clock period specification. The ADC clock source options are the following:

- F<sub>OSC</sub>/2\*n (where 'n' is from 1 to 128)
- FRC (dedicated RC oscillator)

The time to complete one bit conversion is defined as the T<sub>AD</sub>. The following figure shows the complete timing details of the ADC conversion.

Figure 20-2. Analog-to-Digital Conversion T<sub>AD</sub> Cycles



For correct conversion, the appropriate T<sub>AD</sub> specification must be met. Access the "ADC Timing Specifications" link at the end of this topic for more information. The following table below gives examples of appropriate ADC clock selections.



**Important:**

1. Unless using the FRC, any changes in the system clock frequency will change the ADC clock frequency, which may adversely affect the ADC result.
2. The internal control logic of the ADC runs off of the clock selected by the CS bit. What this can mean is when the CS is set to '1' (ADC runs on FRC), there may be unexpected delays in operation when setting ADC control bits.

Table 20-2. ADC Clock Period (T<sub>AD</sub>) Vs. Device Operating Frequencies<sup>(1,4)</sup>

ADC Clock Period (T <sub>AD</sub> )		Device Frequency (F <sub>OSC</sub> )						
ADC Clock Source	ADCLK	64 MHz	32 MHz	20 MHz	16 MHz	8 MHz	4 MHz	1 MHz
F <sub>OSC</sub> /2	000000	31.25 ns <sup>(2)</sup>	62.5 ns <sup>(2)</sup>	100 ns <sup>(2)</sup>	125 ns <sup>(2)</sup>	250 ns <sup>(2)</sup>	500 ns <sup>(2)</sup>	2.0 μs
F <sub>OSC</sub> /4	000001	62.5 ns <sup>(2)</sup>	125 ns <sup>(2)</sup>	200 ns <sup>(2)</sup>	250 ns <sup>(2)</sup>	500 ns <sup>(2)</sup>	1.0 μs	4.0 μs



ADC Clock Period ( $T_{AD}$ )		Device Frequency ( $F_{OSC}$ )						
ADC Clock Source	ADCLK	64 MHz	32 MHz	20 MHz	16 MHz	8 MHz	4 MHz	1 MHz
$F_{OSC}/6$	000010	93.75 ns <sup>(2)</sup>	187.5 ns <sup>(2)</sup>	300 ns <sup>(2)</sup>	375 ns <sup>(2)</sup>	750 ns <sup>(2)</sup>	1.5 $\mu$ s	6.0 $\mu$ s
$F_{OSC}/8$	000011	125 ns <sup>(2)</sup>	250 ns <sup>(2)</sup>	400 ns <sup>(2)</sup>	500 ns <sup>(2)</sup>	1.0 $\mu$ s	2.0 $\mu$ s	8.0 $\mu$ s
...	...	...	...	...	...	...	...	...
$F_{OSC}/16$	000100	250 ns <sup>(2)</sup>	500 ns <sup>(2)</sup>	800 ns <sup>(2)</sup>	1.0 $\mu$ s	2.0 $\mu$ s	4.0 $\mu$ s	16.0 $\mu$ s <sup>(3)</sup>
...	...	...	...	...	...	...	...	...
$F_{OSC}/128$	111111	2.0 $\mu$ s	4.0 $\mu$ s	6.4 $\mu$ s	8.0 $\mu$ s	16.0 $\mu$ s <sup>(3)</sup>	32.0 $\mu$ s <sup>(2)</sup>	128.0 $\mu$ s <sup>(2)</sup>
FRC	CS(ADCON0<4>) = 1	1.0-6.0 $\mu$ s	1.0-6.0 $\mu$ s	1.0-6.0 $\mu$ s	1.0-6.0 $\mu$ s	1.0-6.0 $\mu$ s	1.0-6.0 $\mu$ s	1.0-6.0 $\mu$ s

**Note:**

1. See  $T_{AD}$  parameter in the "Electrical Specifications" section for FRC source typical  $T_{AD}$  value.
2. These values violate the required  $T_{AD}$  time.
3. Outside the recommended  $T_{AD}$  time.
4. The ADC clock period ( $T_{AD}$ ) and total ADC conversion time can be minimized when the ADC clock is derived from the system clock  $F_{OSC}$ . However, the FRC oscillator source must be used when conversions are to be performed with the device in Sleep mode.

**Related Links**

[20.8.1 ADCON0](#)

[42.4.8 Analog-to-Digital Converter \(ADC\) Conversion Timing Specifications](#)

**20.1.5 Interrupts**

The ADC module allows for the ability to generate an interrupt upon completion of an Analog-to-Digital Conversion. The ADC Interrupt Flag is the ADIF bit in the PIRx register. The ADC Interrupt Enable is the ADIE bit in the PIEx register. The ADIF bit must be cleared in software.



**Important:**

1. The ADIF bit is set at the completion of every conversion, regardless of whether or not the ADC interrupt is enabled.
2. The ADC operates during Sleep only when the FRC oscillator is selected.

This interrupt can be generated while the device is operating or while in Sleep. If the device is in Sleep, the interrupt will wake-up the device. Upon waking from Sleep, the next instruction following the `SLEEP` instruction is always executed. If the user is attempting to wake-up from Sleep and resume in-line code execution, the ADIE bit and the PEIE bit of the INTCON register must both be set and the GIE bit of the

INTCON register must be cleared. If all three of these bits are set, the execution will switch to the Interrupt Service Routine.

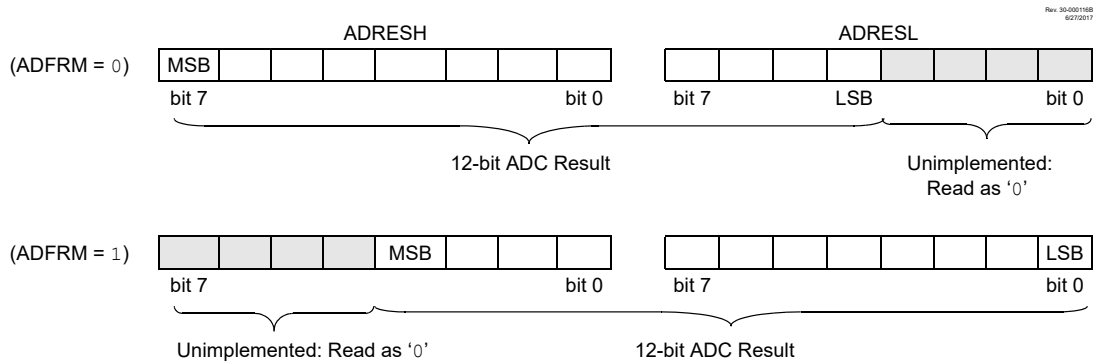
**20.1.6 Result Formatting**

The 12-bit ADC conversion result can be supplied in two formats, left justified or right justified. The **FRM** bit controls the output format.

The figure below shows the two output formats.

Writes to the ADRES register pair are always right justified regardless of the selected format mode. Therefore, data read after writing to ADRES when **FRM** = 0 will be shifted left four places.

**Figure 20-3. 12-Bit ADC Conversion Result Format**



**20.2 ADC Operation**

**20.2.1 Starting a Conversion**

To enable the ADC module, the **ON** bit must be set to a '1'. A conversion may be started by any of the following:

- Software setting the **GO** bit to '1'
- An external trigger (source selected by [20.8.22 ADOACT](#))
- A continuous-mode retrigger (see "Continuous Sampling mode" section.)



**Important:** The **GO** bit should not be set in the same instruction that turns on the ADC.

**Related Links**

- [20.2.7 ADC Conversion Procedure \(Basic Mode\)](#)
- [20.6.8 Continuous Sampling Mode](#)
- [20.8.1 ADCON0](#)
- [20.8.3 ADCON2](#)

### 20.2.2 Completion of a Conversion

When any individual conversion is complete, the value already in ADRES is written into ADPREV (if **PSIS** = 1) and the new conversion result appears in ADRES. When the conversion completes, the ADC module will:

- Clear the **GO** bit (unless the **CONT** bit is set)
- Set the ADIF Interrupt Flag bit
- Set the **MATH** bit
- Update ADACC

When **DSEN** = 0 then after every conversion, or when **DSEN** = 1 then after every other conversion, the following events occur:

- ADERR is calculated
- ADTIF interrupt is set if ADERR calculation meets threshold comparison

Importantly, filter and threshold computations occur after the conversion itself is complete. As such, interrupt handlers responding to ADIF should check ADTIF before reading filter and threshold results.

### 20.2.3 Terminating a Conversion

If a conversion must be terminated before completion, the **GO** bit can be cleared in software. The ADRESH and ADRESL registers will be updated with the partially complete Analog-to-Digital conversion sample. Incomplete bits will match the last bit converted. In this case, filter and/or threshold occur.



**Important:** A device Reset forces all registers to their Reset state. Thus, the ADC module is turned off and any pending conversion is terminated.

### 20.2.4 ADC Operation During Sleep

The ADC module can operate during Sleep. This requires the ADC clock source to be set to the ADCRC option. When the ADCRC oscillator source is selected, the ADC waits one additional instruction before starting the conversion. This allows the **SLEEP** instruction to be executed, which can reduce system noise during the conversion. If the ADC interrupt is enabled, the device will wake-up from Sleep when the conversion completes. If the ADC interrupt is disabled, the ADC module is turned off after the conversion completes, although the **ON** bit remains set.

### 20.2.5 External Trigger During Sleep

If the external trigger is received during sleep while the ADC clock source is set to the FRC, the ADC module will perform the conversion and set the ADIF bit upon completion.

If an external trigger is received when the ADC clock source is something other than FRC, the trigger will be recorded, but the conversion will not begin until the device exits Sleep.

### 20.2.6 Auto-Conversion Trigger

The auto-conversion trigger allows periodic ADC measurements without software intervention. When a rising edge of the selected source occurs, the **GO** bit is set by hardware.

The auto-conversion trigger source is selected by the **ACT** bits.

Using the Auto-conversion Trigger does not assure proper ADC timing. It is the user's responsibility to ensure that the ADC timing requirements are met. See the following table for auto-conversion sources.

Table 20-3. ADC Auto-Conversion Trigger Sources

ACT	Auto-conversion Trigger Source
11111	Software write to ADPCH
11110	Reserved, do not use
11101	Software read of ADRESH
11100	Software read of ADERRH
11011	Reserved, do not use
11010	Reserved, do not use
11001	SMT2_trigger
11000	CCP5_trigger
10111	CLC4_out
10110	CLC3_out
10101	CLC2_out
10100	CLC1_out
10011	Logical OR of all Interrupt-on-change Interrupt Flags
10010	C2_out
10001	C1_out
10000	NCO1_out
01111	PWM7_out
01110	PWM6_out
01101	CCP4_trigger
01100	CCP3_trigger
01011	CCP2_trigger
01010	CCP1_trigger
01001	SMT1_trigger
01000	TMR6_postscaled
00111	TMR5_overflow
00110	TMR4_postscaled
00101	TMR3_overflow
00100	TMR2_postscaled
00011	TMR1_overflow
00010	TMR0_overflow

ACT	Auto-conversion Trigger Source
00001	Pin selected by ADOACTPPS
00000	External Trigger Disabled

### 20.2.7 ADC Conversion Procedure (Basic Mode)

This is an example procedure for using the ADC to perform an Analog-to-Digital conversion:

1. Configure Port:
  - 1.1. Disable pin output driver (Refer to the TRISx register)
  - 1.2. Configure pin as analog (Refer to the ANSELx register)
2. Configure the ADC module:
  - 2.1. Select ADC conversion clock
  - 2.2. Configure voltage reference
  - 2.3. Select ADC input channel (precharge+acquisition)
  - 2.4. Turn on ADC module
3. Configure ADC interrupt (optional):
  - 3.1. Clear ADC interrupt flag
  - 3.2. Enable ADC interrupt
  - 3.3. Enable peripheral interrupt (PIE bit)
  - 3.4. Enable global interrupt (GIE bit) (see Note 1 below)
4. If ADACQ = 0, software must wait the required acquisition time (see Note 2 below).
5. Start conversion by setting the GO bit.
6. Wait for ADC conversion to complete by one of the following:
  - 6.1. Polling the GO bit
  - 6.2. Polling the ADIF bit
  - 6.3. Waiting for the ADC interrupt (interrupts enabled)
7. Read ADC Result.
8. Clear the ADC interrupt flag (required if interrupt is enabled).



#### Important:

1. The global interrupt can be disabled if the user is attempting to wake-up from Sleep and resume in-line code execution.
2. Refer to the “ADC Acquisition Requirements” section.

#### Example 20-1. ADC Conversion (assembly)

```

; This code block configures the ADC for polling, Vdd and Vss references,
; FRC oscillator, and AN0 input.
; Conversion start & polling for completion are included.
;
    BANKSEL ADCON1      ;
    movlw  B'11110000'  ;Right justify, FRC oscillator
    movwf  ADCON1       ;Vdd and Vss Vref
    BANKSEL TRISA      ;
    bsf    TRISA,0      ;Set RA0 to input
    BANKSEL ANSEL      ;
    bsf    ANSEL,0      ;Set RA0 to analog
    BANKSEL ADCON0     ;
    movlw  B'00000001'  ;Select channel AN0

```

```

movwf  ADCON0    ;Turn ADC On
call   SampleTime ;Acquisiton delay
bsf    ADCON0,ADGO ;Start conversion
btfsc  ADCON0,ADGO ;Is conversion done?
goto   $-1      ;No, test again
BANKSEL ADRESH  ;
movf   ADRESH,W ;Read upper 2 bits
movwf  RESULTHI ;store in GPR space
movf   ADRESL,W ;Read lower 8 bits
movwf  RESULTLO ;Store in GPR space

```

### Example 20-2. ADC Conversion (C)

```

/*This code block configures the ADC
for polling, VDD and VSS references, ADCRC
oscillator and AN0 input.
Conversion start & polling for completion
are included.
*/
void main() {
//System Initialize
initializeSystem();

//Setup ADC
ADCON0bits.FM = 1; //right justify
ADCON0bits.CS = 1; //FRC Clock
ADPCH = 0x00; //RA0 is Analog channel
TRISAbits.TRISA0 = 1; //Set RA0 to input
ANSELAbits.ANSELA0 = 1; //Set RA0 to analog
ADCON0bits.ON = 1; //Turn ADC On

while (1) {
ADCON0bits.GO = 1; //Start conversion
while (ADCON0bits.GO); //Wait for conversion done
resultHigh = ADRESH; //Read result
resultLow = ADRESL; //Read result
}
}

```

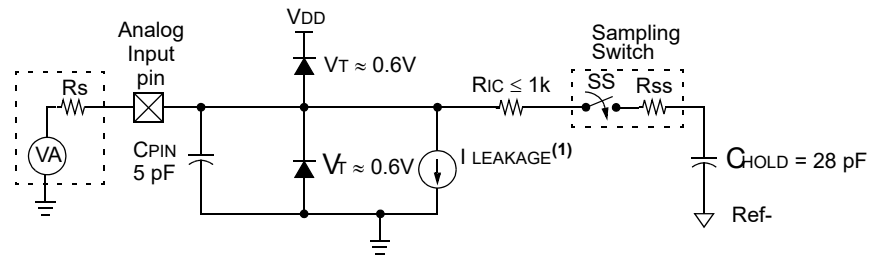
#### Related Links

[20.3 ADC Acquisition Requirements](#)

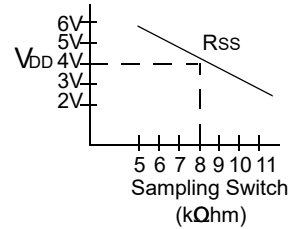
## 20.3 ADC Acquisition Requirements

For the ADC to meet its specified accuracy, the charge holding capacitor ( $C_{\text{HOLD}}$ ) must be allowed to fully charge to the input channel voltage level. The Analog Input model is shown in the following figure. The source impedance ( $R_S$ ) and the internal sampling switch ( $R_{\text{SS}}$ ) impedance directly affect the time required to charge the capacitor  $C_{\text{HOLD}}$ . The sampling switch ( $R_{\text{SS}}$ ) impedance varies over the device voltage ( $V_{\text{DD}}$ ), refer to the following figure.

**Figure 20-4. Analog Input Model**



- Legend:**
- $C_{HOLD}$  = Sample/Hold Capacitance
  - $C_{PIN}$  = Input Capacitance
  - $I_{LEAKAGE}$  = Leakage current at the pin due to various junctions
  - $R_{IC}$  = Interconnect Resistance
  - $R_{SS}$  = Resistance of Sampling Switch
  - $SS$  = Sampling Switch
  - $V_T$  = Threshold Voltage



**Note:**

1. Refer to “I/O Ports Electrical Specifications”.



**Important:** The maximum recommended impedance for analog sources is 10 kΩ.

If the source impedance is decreased, the acquisition time may be decreased. After the analog input channel is selected (or changed), an ADC acquisition must be completed before the conversion can be started. To calculate the minimum acquisition time, the following equation may be used. This equation assumes that 1/2 LSB error is used (4,096 steps for the ADC). The 1/2 LSB error is the maximum error allowed for the ADC to meet its specified resolution.

**Equation 20-1. Acquisition Time Example**

Assumptions: Temperature = 50°C and external impedance pf 10 kΩ 5.0V  $V_{DD}$

$T_{ACQ}$  = Amplifier Settling Time + Hold Capacitor Charging Time + Temperature Coefficient

$$= T_{AMP} + T_C + T_{COFF}$$

$$= 2 \mu s + T_C + [(Temperature - 25^\circ C)(0.05 \mu s/^\circ C)]$$

The value for  $T_C$  can be approximated with the following equations:

$$V_{APPLIED} \left( 1 - \frac{1}{(2^n + 1) - 1} \right) = V_{CHOLD} \quad ; [1] V_{CHOLD} \text{ charged to within } 1/2 \text{ lsb}$$

$$V_{APPLIED} \left( 1 - e^{-\frac{T_C}{RC}} \right) = V_{CHOLD} \quad ; [2] V_{CHOLD} \text{ charge response to } V_{APPLIED}$$

$$V_{APPLIED} \left( 1 - e^{-\frac{T_C}{R_C}} \right) = V_{APPLIED} \left( 1 - \frac{1}{(2^n + 1) - 1} \right) \quad ; \text{combining [1] and [2]}$$

**Note:** Where n = number of bits of the ADC.

Solving for  $T_C$ :

$$T_C = -C_{HOLD}(R_{IC} + R_{SS} + R_S) \ln(1/8191)$$

$$T_C = -28pF(1k\Omega + 7k\Omega + 10k\Omega) \ln(0.0001221)$$

$$T_C = 4.54us$$

Therefore:

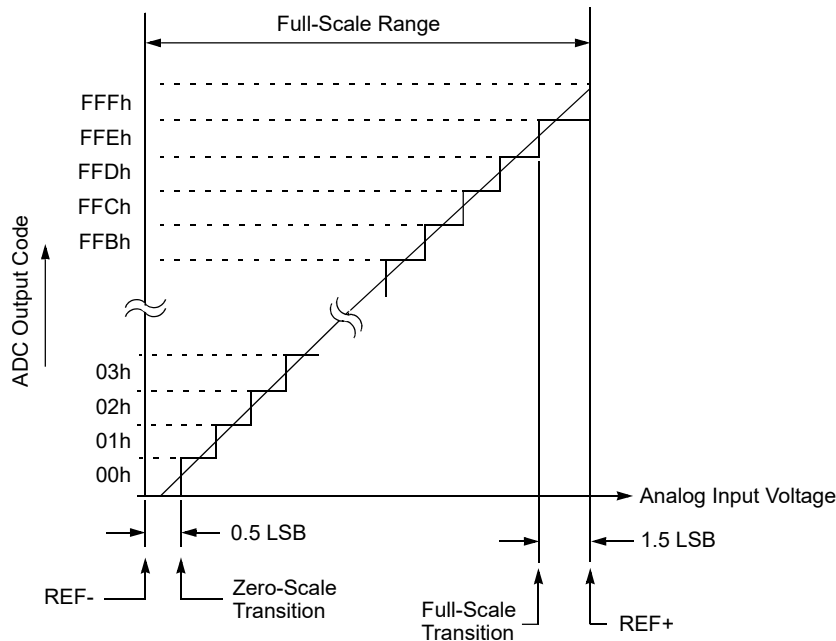
$$T_{ACQ} = 2us + 4.54us + [(50^\circ C - 25^\circ C)(0.05us/^\circ C)]$$

$$T_{ACQ} = 7.79us$$

**Note:**

1. The reference voltage ( $V_{REF}$ ) has no effect on the equation, since it cancels itself out.
2. The charge holding capacitor ( $C_{HOLD}$ ) is not discharged after each conversion.
3. The maximum recommended impedance for analog sources is 10 k $\Omega$ . This is required to meet the pin leakage specification.

**Figure 20-5. ADC Transfer Function**



**Related Links**

[42.4.4 I/O and CLKOUT Timing Specifications](#)



## 20.4 ADC Charge Pump

The ADC module has a dedicated charge pump that can be controlled through the ADCPCON0 register. The primary purpose of the charge pump is to supply a constant voltage to the gates of transistor devices in the A/D converter, signal and reference input pass-gates, to prevent degradation of transistor performance at low operating voltage.

The charge pump can be enabled by setting the CPON bit. Once enabled, the pump will undergo a start-up time to stabilize the charge pump output. Once the output stabilizes and is ready for use, the CPRDY bit will be set.

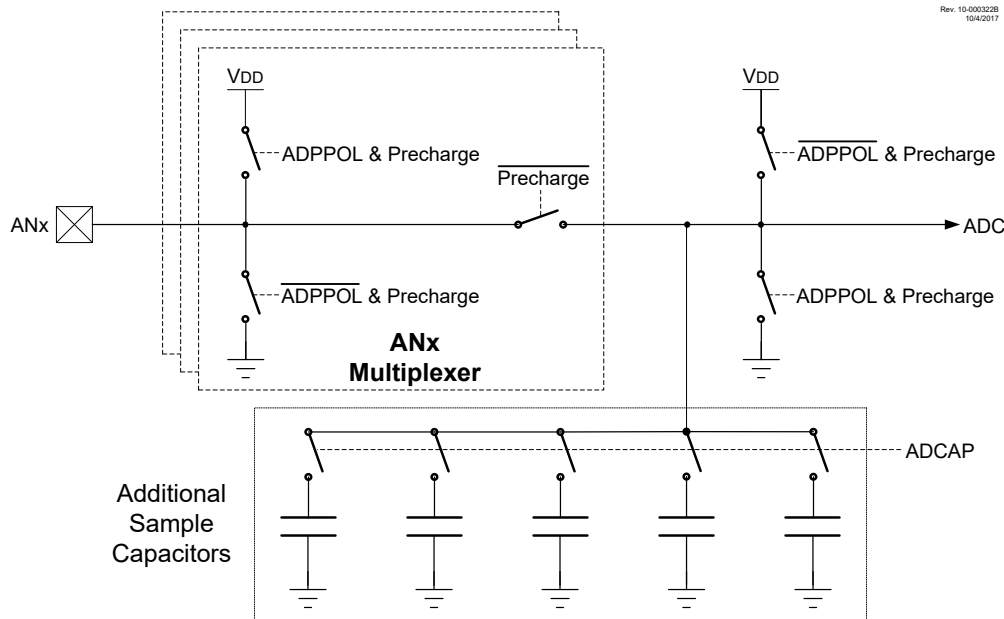
### Related Links

[20.8.23 ADCPCON0](#)

## 20.5 Capacitive Voltage Divider (CVD) Features

The ADC module contains several features that allow the user to perform a relative capacitance measurement on any ADC channel using the internal ADC sample and hold capacitance as a reference. This relative capacitance measurement can be used to implement capacitive touch or proximity sensing applications. The following figure shows the basic block diagram of the CVD portion of the ADC module.

Figure 20-6. Hardware Capacitive Voltage Divider Block Diagram

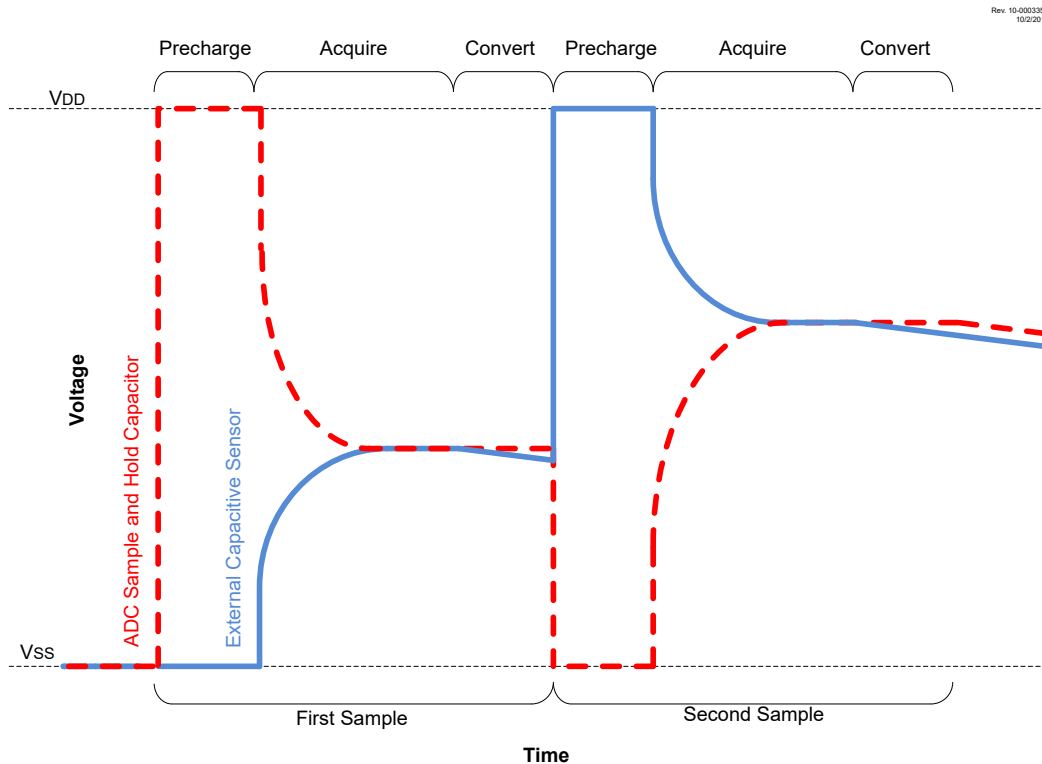


### 20.5.1 CVD Operation

A CVD operation begins with the ADC's internal sample and hold capacitor ( $C_{HOLD}$ ) being disconnected from the path which connects it to the external capacitive sensor node. While disconnected,  $C_{HOLD}$  is precharged to  $V_{DD}$  or  $V_{SS}$  the sensor node is also charged to  $V_{SS}$  or  $V_{DD}$ , respectively to the level opposite that of  $C_{HOLD}$ . When the precharge phase is complete, the  $V_{DD}/V_{SS}$  bias paths for the two nodes are shut off and the paths between  $C_{HOLD}$  and the external sensor node is reconnected, at which time the acquisition phase of the CVD operation begins. During acquisition, a capacitive voltage divider is formed between the precharged  $C_{HOLD}$  and sensor nodes, which results in a final voltage level setting on  $C_{HOLD}$ .

which is determined by the capacitances and precharge levels of the two nodes. After acquisition, the ADC converts the voltage level on  $C_{HOLD}$ . This process is then repeated with the selected precharge levels inverted for both the  $C_{HOLD}$  and the sensor nodes. The waveform for two CVD measurements, which is known as differential CVD measurement, is shown in the following figure.

Figure 20-7. Differential CVD Measurement Waveform



### 20.5.2 Precharge Control

The Precharge stage is an optional period of time that brings the external channel and internal sample and hold capacitor to known voltage levels. Precharge is enabled by writing a non-zero value to the ADPRE register. This stage is initiated when an ADC conversion begins, either from setting the GO bit, a special event trigger, or a conversion restart from the computation functionality. If the ADPRE register is cleared when an ADC conversion begins, this stage is skipped.

During the precharge time,  $C_{HOLD}$  is disconnected from the outer portion of the sample path that leads to the external capacitive sensor and is connected to either  $V_{DD}$  or  $V_{SS}$ , depending on the value of the PPOL bit. At the same time, the port pin logic of the selected analog channel is overridden to drive a digital high or low out, in order to precharge the outer portion of the ADC's sample path, which includes the external sensor. The output polarity of this override is also determined by the PPOL bit. The amount of time that this charging needs is controlled by the ADPRE register.



**Important:** The external charging overrides the TRIS setting of the respective I/O pin. If there is a device attached to this pin, Precharge should not be used.

#### Related Links

[20.8.2 ADCON1](#)

[20.8.9 ADPRE](#)

### 20.5.3 Acquisition Control for CVD

The Acquisition stage allows time for the voltage on the internal sample and hold capacitor to charge or discharge from the selected analog channel. This acquisition time is controlled by the ADACQ register. If  $ADPRE = 0$ , acquisition starts at the beginning of conversion. When  $ADPRE \neq 0$ , the acquisition stage begins when precharge ends.

At the start of the acquisition stage, the port pin logic of the selected analog channel is overridden to turn off the digital high/low output drivers so they do not affect the final result of the charge averaging. Also, the selected ADC channel is connected to  $C_{HOLD}$ . This allows charge averaging to proceed between the precharged channel and the  $C_{HOLD}$  capacitor.



**Important:** When  $ADPRE \neq 0$  setting ADACQ to '0' will set a maximum acquisition time (8191 ADC clock cycles). When  $ADPRE = 0$ , setting ADACQ to '0' will disable hardware acquisition time control.

---

### 20.5.4 Guard Ring Outputs

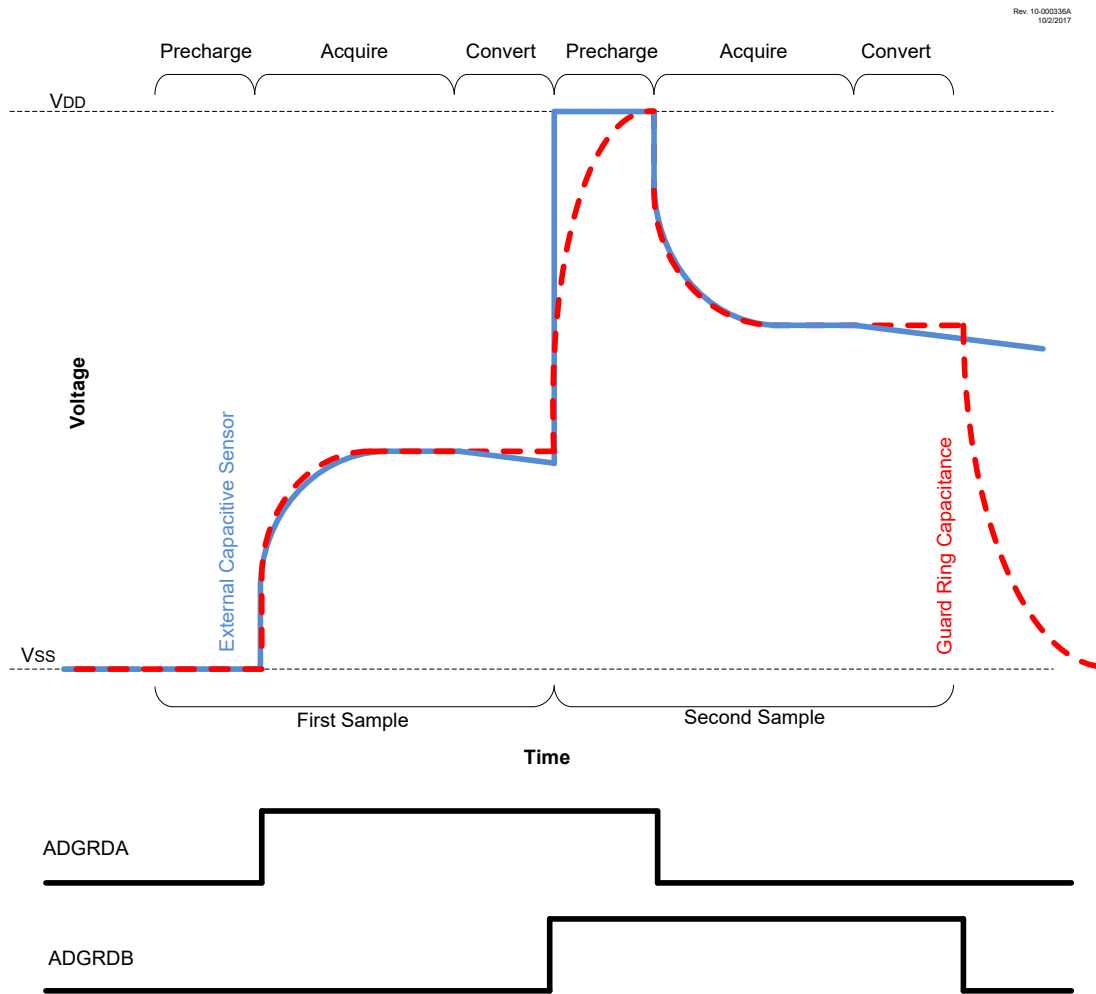
The following figure shows a typical guard ring circuit.  $C_{GUARD}$  represents the capacitance of the guard ring trace placed on the PCB board. The user selects values for  $R_A$  and  $R_B$  that will create a voltage profile on  $C_{GUARD}$ , which will match the selected acquisition channel.

The purpose of the guard ring is to generate a signal in phase with the CVD sensing signal to minimize the effects of the parasitic capacitance on sensing electrodes. It also can be used as a mutual drive for mutual capacitive sensing. For more information about active guard and mutual drive, see [Application Note AN1478, "mTouch™ Sensing Solution Acquisition Methods Capacitive Voltage Divider"](#).

The ADC has two guard ring drive outputs, ADGRDA and ADGRDB. These outputs can be routed through PPS controls to I/O pins (see "[Peripheral Pin Select \(PPS\) Module](#)" for details) and the polarity of these outputs are controlled by the [GPOL](#) and [IPEN](#) bits.

At the start of the first precharge stage, both outputs are set to match the [GPOL](#) bit. Once the acquisition stage begins, ADGRDA changes polarity, while ADGRDB remains unchanged. When performing a double sample conversion, setting the [IPEN](#) bit causes both guard ring outputs to transition to the opposite polarity of [GPOL](#) at the start of the second precharge stage, and ADGRDA toggles again for the second acquisition. For more information on the timing of the guard ring output, refer to the two following figures.

Figure 20-8. Differential CVD with Guard Ring Output Waveform



**Related Links**

[20.8.2 ADCON1](#)

[15. \(PPS\) Peripheral Pin Select Module](#)

**20.5.5 Additional Sample and Hold Capacitance**

Additional capacitance can be added in parallel with the internal sample and hold capacitor ( $C_{HOLD}$ ) by using the ADCAP register. This register selects a digitally programmable capacitance, which is added to the ADC conversion bus, increasing the effective internal capacitance of the sample and hold capacitor in the ADC module. This is used to improve the match between internal and external capacitance for a better sensing performance. The additional capacitance does not affect analog performance of the ADC because it is not connected during conversion.

**Related Links**

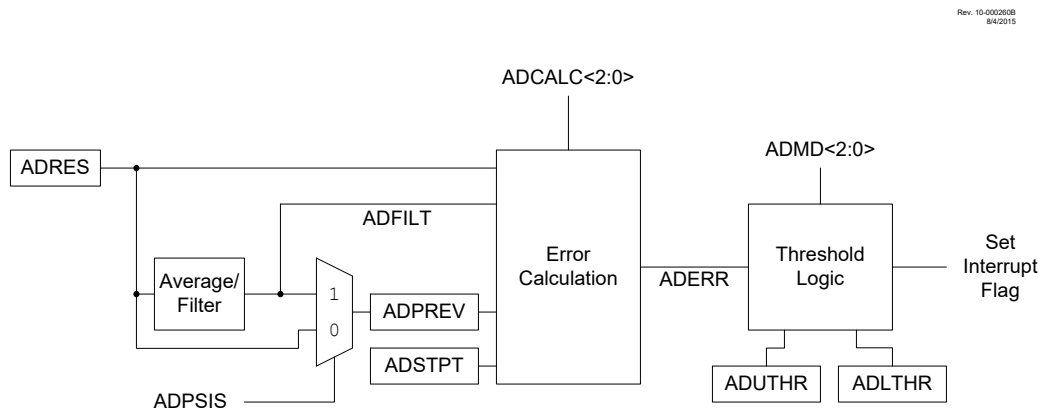
[20.6 Computation Operation](#)

[20.8.11 ADCAP](#)

## 20.6 Computation Operation

The ADC module hardware is equipped with post conversion computation features. These features provide data post-processing functions that can be applied to the ADC conversion result, including digital filtering/averaging and threshold comparison functions.

Figure 20-9. Computational Features Simplified Block Diagram



The operation of the ADC computational features is controlled by MD bits.

The module can be operated in one of five modes:

- **Basic:** This is a legacy mode. In this mode, ADC conversion occurs on single ( $DSEN = 0$ ) or double ( $DSEN = 1$ ) samples. ADIF is set after all the conversions are complete.
- **Accumulate:** With each trigger, the ADC conversion result is added to accumulator and ADCNT increments. ADIF is set after each conversion. ADTIF is set according to the calculation mode.
- **Average:** With each trigger, the ADC conversion result is added to the accumulator. When the ADRPT number of samples have been accumulated, a threshold test is performed. Upon the next trigger, the accumulator is cleared. For the subsequent tests, additional ADRPT samples are required to be accumulated.
- **Burst Average:** At the trigger, the accumulator is cleared. The ADC conversion results are then collected repetitively until ADRPT samples are accumulated and finally the threshold is tested.
- **Low-Pass Filter (LPF):** With each trigger, the ADC conversion result is sent through a filter. When ADRPT samples have occurred, a threshold test is performed. Every trigger after that, the ADC conversion result is sent through the filter and another threshold test is performed.

The five modes are summarized in following table.

**Table 20-4. Computation Modes**

Mode	ADMD	Bit Clear Conditions ADACC and ADCNT	Value after Trigger completion		Threshold Operations			Value at ADTIF interrupt		
			ADACC	ADCNT	Retrigger	Threshold Test	Interrupt	ADAOV	ADFLTR	ADCNT
Basic	0	ADACLR = 1	Unchanged	Unchanged	No	Every Sample	If threshold=true	N/A	N/A	count
Accumulate	1	ADACLR = 1	S + ADACC or (S2-S1) + ADACC	If (ADCNT=FF): ADCNT, otherwise: ADCNT+1	No	Every Sample	If threshold=true	ADACC Overflow	ADACC/ 2 <sup>ADCRS</sup>	count
Average	2	ADACLR = 1 or ADCNT >= ADRPT at ADGO or retrigger	S + ADACC or (S2-S1) + ADACC	If (ADCNT=FF): ADCNT, otherwise: ADCNT+1	No	If ADCNT >= ADRPT	If threshold=true	ADACC Overflow	ADACC/ 2 <sup>ADCRS</sup>	count
Burst Average	3	ADACLR = 1 or ADGO set or retrigger	Each repetition: same as Average End with sum of all samples	Each repetition: same as Average End with ADCNT=ADRPT	Repeat while ADCNT < ADRPT	If ADCNT >= ADRPT	If threshold=true	ADACC Overflow	ADACC/ 2 <sup>ADCRS</sup>	ADRPT
Low-pass Filter	4	ADACLR = 1	S+ADACC- ADACC/ 2 <sup>ADCRS</sup> or (S2- S1)+ADACC- ADACC/ 2 <sup>ADCRS</sup>	If (ADCNT=FF): ADCNT, otherwise: ADCNT+1	No	If ADCNT >= ADRPT	If threshold=true	ADACC Overflow	Filtered Value	count

**Note:** S1 and S2 are abbreviations for Sample 1 and Sample 2, respectively. When **DSEN** = 0, S1 = ADRES; When **DSEN** = 1, S1 = ADPREV and S2 = ADRES.

### 20.6.1 Digital Filter/Average

The digital filter/average module consists of an accumulator with data feedback options, and control logic to determine when threshold tests need to be applied. The accumulator is a 16-bit wide register that can be accessed through the ADACCH:ADACCL register pair.

Upon each trigger event (the GO bit set or external event trigger), the ADC conversion result is added to the accumulator. If the accumulated result exceeds  $2^{(\text{accumulator\_width})}-1$ , the OV Accumulator Overflow bit is set.

The number of samples to be accumulated is determined by the ADRPT (A/D Repeat Setting) register. Each time a sample is added to the accumulator, the ADCNT register is incremented. Once ADRPT samples are accumulated (ADCNT = ADRPT), an accumulator clear command can be issued by the software by setting the ACLR bit. Setting the ACLR bit will also clear the OV bit, as well as the ADCNT register. The ACLR bit is cleared by the hardware when accumulator clearing action is complete.



**Important:** When ADC is operating from FRC, five FRC clock cycles are required to execute the ADACC clearing operation.

The CRS bits control the data shift on the accumulator result, which effectively divides the value in accumulator (ADACCU:ADACCH:ADACCL) register pair. For the Accumulate mode of the digital filter, the shift provides a simple scaling operation. For the Average/Burst Average mode, the Shift bits are used to determine the number of logical right shifts to be performed on the accumulated result. For the Low-pass Filter mode, the shift is an integral part of the filter, and determines the cut-off frequency of the filter. The table below shows the -3 dB cut-off frequency in  $\omega T$  (radians) and the highest signal attenuation obtained by this filter at nyquist frequency ( $\omega T = \pi$ ).

**Table 20-5. Low-pass Filter -3 dB Cut-off Frequency**

CRS	$\omega T$ (radians) @ -3 dB Frequency	dB @ $F_{\text{nyquist}}=1/(2T)$
1	0.72	-9.5
2	0.284	-16.9
3	0.134	-23.5
4	0.065	-29.8
5	0.032	-36.0
6	0.016	-42.0
7	0.0078	-48.1

### 20.6.2 Basic Mode

Basic mode (MD = 000) disables all additional computation features. In this mode, no accumulation occurs but threshold error comparison is performed. Double sampling, Continuous mode, and all CVD features are still available, but no features involving the digital filter/average features are used.

### 20.6.3 Accumulate Mode

In Accumulate mode (MD = 001), after every conversion, the ADC result is added to the ADACC register. The ADACC register is right-shifted by the value of the CRS bits. This right-shifted value is copied into the ADFLT register. The Formatting mode does not affect the right-justification of the ADFLT value. Upon

each sample, ADCNT is also incremented, incrementing the number of samples accumulated. After each sample and accumulation, the ADACC value has a threshold comparison performed on it and the ADTIF interrupt may trigger.

#### Related Links

[20.6.7 Threshold Comparison](#)

#### 20.6.4 Average Mode

In Average Mode ( $MD = 010$ ), the ADACC registers accumulate with each ADC sample, much as in Accumulate mode, and the ADCNT register increments with each sample. The ADFLT register is also updated with the right-shifted value of the ADACC register. The value of the CRS bits govern the number of right shifts. However, in Average mode, the threshold comparison is performed upon ADCNT being greater than or equal to a user-defined ADRPT value. In this mode when  $ADCNT = 2^{ADCRS}$ , then the final accumulated value will be divided by number of samples, allowing for a threshold comparison operation on the average of all gathered samples.

#### 20.6.5 Burst Average Mode

The Burst Average mode ( $MD = 011$ ) acts the same as the Average mode in most respects. The one way it differs is that it continuously retriggers ADC sampling until the ADCNT value is greater than or equal to ADRPT, even if Continuous Sampling mode is not enabled. This allows for a threshold comparison on the average of a short burst of ADC samples.

#### Related Links

[20.6.8 Continuous Sampling Mode](#)

#### 20.6.6 Low-pass Filter Mode

The Low-pass Filter mode ( $MD = 100$ ) acts similarly to the Average mode in how it handles samples (accumulates samples until ADCNT value greater than or equal to ADRPT, then triggers threshold comparison), but instead of a simple average, it performs a low-pass filter operation on all of the samples, reducing the effect of high-frequency noise on the average, then performs a threshold comparison on the results. In this mode, the CRS bits determine the cut-off frequency of the low-pass filter.

#### Related Links

[20.6.1 Digital Filter/Average](#)

[20.6 Computation Operation](#)

#### 20.6.7 Threshold Comparison

At the end of each computation:

- The conversion results are latched and held stable at the end-of-conversion.
- The error (ADERR) is calculated based on a difference calculation which is selected by the CALC bits. The value can be one of the following calculations (see table below for more details):
  - The first derivative of single measurements
  - The CVD result in CVD mode
  - The current result vs. a setpoint
  - The current result vs. the filtered/average result
  - The first derivative of the filtered/average value
  - Filtered/average value vs. a setpoint
- The result of the calculation (ADERR) is compared to the upper and lower thresholds, ADUTH<UTHH:UTHL> and ADLTH<LTHH:LTHL> registers, to set the UTHR and LTHR flag bits.



The threshold logic is selected by **TMD** bits. The threshold trigger option can be one of the following:

- Never interrupt
- Error is less than lower threshold
- Error is greater than or equal to lower threshold
- Error is between thresholds (inclusive)
- Error is outside of thresholds
- Error is less than or equal to upper threshold
- Error is greater than upper threshold
- Always interrupt regardless of threshold test results
- If the threshold condition is met, the threshold interrupt flag ADTIF is set.

**Note:**

1. The threshold tests are signed operations.
2. If **OV** is set, a threshold interrupt is signaled. It is good practice for threshold interrupt handlers to verify the validity of the threshold by checking ADAOV.

**Table 20-6. ADC Error Calculation Mode**

CALC	Action During 1st Precharge Stage		Application
	DSEN = 0 Single-Sample Mode	DSEN = 1 CVD Double-Sample Mode <sup>(1)</sup>	
111	Reserved	Reserved	Reserved
110	Reserved	Reserved	Reserved
101	ADLFTR-ADSTPT	ADFLTR-ADSTPT	Average/filtered value vs. setpoint
100	ADPREV-ADFLTR	ADPREV-ADFLTR	First derivative of filtered value <sup>(3)</sup> (negative)
011	Reserved	Reserved	Reserved
010	ADRES-ADFLTR	(ADRES-ADPREV)-ADFLTR	Actual result vs. averaged/filtered value
001	ADRES-ADSTPT	(ADRES-ADPREV)-ADSTPT	Actual result vs. setpoint
000	ADRES-ADPREV	ADRES-ADPREV	First derivative of single measurement <sup>(2)</sup>
			Actual CVD result in CVD mode <sup>(2)</sup>

**Note:**

1. When **PSIS** = 0, the value of ADRES-ADPREV) is the value of (S2-S1) from **Computation Modes**.
2. When **PSIS** = 0
3. When **PSIS** = 1.

**20.6.8 Continuous Sampling Mode**

Setting the **CONT** bit automatically retriggers a new conversion cycle after updating the ADACC register. The **GO** bit remains set and retriggering occurs automatically.

If **SOI** = 1, a threshold interrupt condition will clear **GO** and the conversions will stop.

#### **20.6.9 Double Sample Conversion**

Double sampling is enabled by setting the **DSEN** bit. When this bit is set, two conversions are required before the module will calculate threshold error (each conversion must still be triggered separately). The first conversion will set the **MATH** bit and update **ADACC**, but will not calculate **ADERR** or trigger **ADTIF**. When the second conversion completes, the first value is transferred to **ADPREV** (depending on the setting of **PSIS**) and the value of the second conversion is placed into **ADRES**. Only upon the completion of the second conversion is **ADERR** calculated and **ADTIF** triggered (depending on the value of **CALC**).

## 20.7 Register Summary - ADC Control

Address	Name	Bit Pos.								
0x8C	ADLTH	7:0	LTHL[7:0]							
		15:8	LTHH[7:0]							
0x8E	ADUTH	7:0	UTHL[7:0]							
		15:8	UTHH[7:0]							
0x90	ADERR	7:0	ADERRL[7:0]							
		15:8	ERRH[7:0]							
0x92	ADSTPT	7:0	STPTL[7:0]							
		15:8	STPTH[7:0]							
0x94	ADFLTR	7:0	FLTRL[7:0]							
		15:8	FLTRH[7:0]							
0x96	ADACC	7:0	ACCL[7:0]							
		15:8	ACCH[7:0]							
		23:16	ACCU[1:0]							
0x99	ADCNT	7:0	CNT[7:0]							
0x9A	ADRPT	7:0	RPT[7:0]							
0x9B	ADPREV	7:0	PREVL[7:0]							
		15:8	PREVH[7:0]							
0x9D	ADRES	7:0	RESL[7:0]							
		15:8	RESH[7:0]							
0x9F	ADPCH	7:0	PCH[5:0]							
0xA0 ... 0x010B	Reserved									
0x010C	ADACQ	7:0	ACQL[7:0]							
		15:8	ACQH[4:0]							
0x010E	ADCAP	7:0	CAP[4:0]							
0x010F	ADPRE	7:0	PREL[7:0]							
		15:8	PREH[4:0]							
0x0111	ADCON0	7:0	ON	CONT		CS		FRM		GO
0x0112	ADCON1	7:0	PPOL	IPEN	GPOL					DSEN
0x0113	ADCON2	7:0	PSIS	CRS[2:0]			ACLR	MD[2:0]		
0x0114	ADCON3	7:0		CALC[2:0]			SOI	TMD[2:0]		
0x0115	ADSTAT	7:0	OV	UTHR	LTHR	MATH		STAT[2:0]		
0x0116	ADREF	7:0				NREF		PREF[1:0]		
0x0117	ADACT	7:0	ACT[4:0]							
0x0118	ADCLK	7:0	CS[5:0]							
0x0119 ... 0x029E	Reserved									
0x029F	ADPCON0	7:0	CPON							CPRDY

## 20.8 Register Definitions: ADC Control

Long bit name prefixes for the ADC peripherals are shown in the table below. Refer to the "Long Bit Names Section" for more information.

**Table 20-7. ADC Long Bit Name Prefixes**

Peripheral	Bit Name Prefix
ADC <sup>2</sup>	AD

### Related Links

[1.4.2.2 Long Bit Names](#)

20.8.1 ADCON0

**Name:** ADCON0  
**Address:** 0x111

ADC Control Register 0

Bit	7	6	5	4	3	2	1	0
	ON	CONT		CS		FRM		GO
Access	R/W	R/W		R/W		R/W		R/W/HC
Reset	0	0		0		0		0

**Bit 7 – ON** ADC Enable bit

Value	Description
1	ADC is enabled
0	ADC is disabled

**Bit 6 – CONT** ADC Continuous Operation Enable bit

Value	Description
1	GO is retriggered upon completion of each conversion trigger until TIF is set (if SOI is set) or until GO is cleared (regardless of the value of SOI)
0	GO is cleared upon completion of each conversion trigger

**Bit 4 – CS** ADC Clock Selection bit

Value	Description
1	Clock supplied from FRC dedicated oscillator
0	Clock supplied by F <sub>OSC</sub> , divided according to ADCLK register

**Bit 2 – FRM** ADC Results Format/Alignment Selection

Value	Description
1	ADRES and ADPREV data are right-justified
0	ADRES and ADPREV data are left-justified, zero-filled

**Bit 0 – GO** ADC Conversion Status bit<sup>(1,2)</sup>

Value	Description
1	ADC conversion cycle in progress. Setting this bit starts an ADC conversion cycle. The bit is cleared by hardware as determined by the CONT bit
0	ADC conversion completed/not in progress

**Note:**

1. This bit requires ON bit to be set.
2. If cleared by software while a conversion is in progress, the results of the conversion up to this point will be transferred to ADRES and the state machine will be reset, but the ADIF interrupt flag bit will not be set; filter and threshold operations will not be performed.

20.8.2 ADCON1

**Name:** ADCON1  
**Address:** 0x112

ADC Control Register 1

Bit	7	6	5	4	3	2	1	0
	PPOL	IPEN	GPOL					DSEN
Access	R/W	R/W	R/W					R/W
Reset	0	0	0					0

**Bit 7 – PPOL** Precharge Polarity bit  
 Action During 1<sup>st</sup> Precharge Stage

Value	Condition	Description
x	PRE=0	Bit has no effect
1	PRE>0 & ADC input is I/O pin	Pin shorted to AV <sub>DD</sub>
0	PRE>0 & ADC input is I/O pin	Pin shorted to V <sub>SS</sub>
1	PRE>0 & ADC input is internal	C <sub>HOLD</sub> Shorted to AV <sub>DD</sub>
0	PRE>0 & ADC input is internal	C <sub>HOLD</sub> Shorted to V <sub>SS</sub>

**Bit 6 – IPEN** A/D Inverted Precharge Enable bit

Value	Condition	Description
x	DSEN = 0	Bit has no effect
1	DSEN = 1	The precharge and guard signals in the second conversion cycle are the opposite polarity of the first cycle
0	DSEN = 1	Both Conversion cycles use the precharge and guards specified by PPOL and GPOL

**Bit 5 – GPOL** Guard Ring Polarity Selection bit

Value	Description
1	ADC guard Ring outputs start as digital high during Precharge stage
0	ADC guard Ring outputs start as digital low during Precharge stage

**Bit 0 – DSEN** Double-Sample Enable bit

Value	Description
1	Two conversions are performed on each trigger. Data from the first conversion appears in PREV
0	One conversion is performed for each trigger

20.8.3 ADCON2

**Name:** ADCON2  
**Address:** 0x113

ADC Control Register 2

Bit	7	6	5	4	3	2	1	0
	PSIS	CRS[2:0]			ACLR	MD[2:0]		
Access	R/W	R/W	R/W	R/W	R/W/HC	R/W	R/W	R/W
Reset	0	0	0	0	0	0	0	0

**Bit 7 – PSIS** ADC Previous Sample Input Select bits

Value	Description
1	FLTR is transferred to PREV at start-of-conversion
0	ADRES is transferred to PREV at start-of-conversion

**Bits 6:4 – CRS[2:0]** ADC Accumulated Calculation Right Shift Select bits

Value	Condition	Description
0 to 7	MD = b'100'	Low-pass filter time constant is $2^{CRS}$ , filter gain is 1:1
0 to 7	MD = b'011' to b'001'	The accumulated value is right-shifted by CRS (divided by $2^{CRS}$ ) (1,2)
x	MD = b'000' to b'001'	These bits are ignored

**Bit 3 – ACLR** A/D Accumulator Clear Command bit<sup>(3)</sup>

Value	Description
1	ACC, OV and CNT bits are cleared
0	Clearing action is complete (or not started)

**Bits 2:0 – MD[2:0]** ADC Operating Mode Selection bits<sup>(4)</sup>

Value	Description
111-101	Reserved
100	Low-pass Filter mode
011	Burst Average mode
010	Average mode
001	Accumulate mode
000	Basic (Legacy) mode

**Note:**

1. To correctly calculate an average, the number of samples (set in RPT) must be  $2^{CRS}$ .
2. CRS = 3'b111 is a reserved option.
3. This bit is cleared by hardware when the accumulator operation is complete; depending on oscillator selections, the delay may be many instructions.
4. See [Computation Modes](#) for full mode descriptions.

20.8.4 ADCON3

**Name:** ADCON3  
**Address:** 0x114

ADC Control Register 3

Bit	7	6	5	4	3	2	1	0
		CALC[2:0]			SOI	TMD[2:0]		
Access		R/W	R/W	R/W	R/W/HC	R/W	R/W	R/W
Reset		0	0	0	0	0	0	0

**Bits 6:4 – CALC[2:0]** ADC Error Calculation Mode Select bits  
 See [ADC Error Calculation Mode](#) table for selection details.

**Bit 3 – SOI** ADC Stop-on-Interrupt bit

Value	Condition	Description
1	CONT = 1	GO is cleared when the threshold conditions are met, otherwise the conversion is retrigged
0	CONT = 1	GO is not cleared by hardware, must be cleared by software to stop retriggers
x	CONT = 0	This bit is not used

**Bits 2:0 – TMD[2:0]** Threshold Interrupt Mode Select bits

Value	Description
111	Interrupt regardless of threshold test results
110	Interrupt if ERR>UTH
101	Interrupt if ERR≤UTH
100	Interrupt if ERR<LTH or ERR>UTH
011	Interrupt if ERR>LTH and ERR<UTH
010	Interrupt if ERR≥LTH
001	Interrupt if ERR<LTH
000	Never interrupt



20.8.5 ADSTAT

**Name:** ADSTAT  
**Address:** 0x115

ADC Status Register

Bit	7	6	5	4	3	2	1	0
	OV	UTHR	LTHR	MATH		STAT[2:0]		
Access	RO	RO	RO	R/HS/HC		RO	RO	RO
Reset	0	0	0	0		0	0	0

**Bit 7 – OV** ADC Accumulator Overflow bit

Value	Description
1	ADC accumulator or ERR calculation have overflowed
0	ADC accumulator and ERR calculation have not overflowed

**Bit 6 – UTHR** ADC Module Greater-than Upper Threshold Flag bit

Value	Description
1	ERR > UTH
0	ERR ≤ UTH

**Bit 5 – LTHR** ADC Module Less-than Lower Threshold Flag bit

Value	Description
1	ERR < LTH
0	ERR ≥ LTH

**Bit 4 – MATH** ADC Module Computation Status bit

Value	Description
1	Registers ADACC, ADFLTR, ADUTH, ADLTH and the OV bit are updating or have already updated
0	Associated registers/bits have not changed since this bit was last cleared

**Bits 2:0 – STAT[2:0]** ADC Module Cycle Multistage Status bits<sup>(1)</sup>

Value	Description
111	ADC module is in 2 <sup>nd</sup> conversion stage
110	ADC module is in 2 <sup>nd</sup> acquisition stage
101	ADC module is in 2 <sup>nd</sup> precharge stage
100	Not used
011	ADC module is in 1 <sup>st</sup> conversion stage
010	ADC module is in 1 <sup>st</sup> acquisition stage
001	ADC module is in 1 <sup>st</sup> precharge stage
000	ADC module is not converting

**Note:**

1. If CS = 1, and F<sub>OSC</sub> < FRC, these bits may be invalid.

20.8.6 ADCLK

**Name:** ADCLK  
**Address:** 0x118

ADC Clock Selection Register

Bit	7	6	5	4	3	2	1	0
			CS[5:0]					
Access			R/W	R/W	R/W	R/W	R/W	R/W
Reset			0	0	0	0	0	0

**Bits 5:0 – CS[5:0]** ADC Conversion Clock Select bits

Value	Description
0 to 63	ADC Clock frequency = $F_{OSC}/(2^{*(CS+1)})$

20.8.7 ADREF

**Name:** ADREF  
**Address:** 0x116

ADC Reference Selection Register

Bit	7	6	5	4	3	2	1	0
				NREF			PREF[1:0]	
Access				R/W			R/W	R/W
Reset				0			0	0

**Bit 4 – NREF** ADC Negative Voltage Reference Selection bit

Value	Description
1	$V_{REF-}$ is connected to external $V_{REF-}$
0	$V_{REF-}$ is connected to $AV_{SS}$

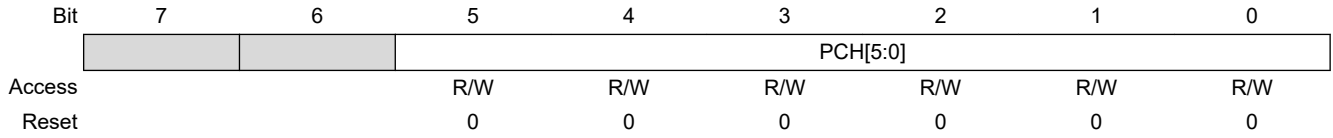
**Bits 1:0 – PREF[1:0]** ADC Positive Voltage Reference Selection bits

Value	Description
11	$V_{REF+}$ is connected to internal Fixed Voltage Reference (FVR) module
10	$V_{REF+}$ is connected to external $V_{REF+}$
01	Reserved
00	$V_{REF+}$ is connected to $V_{DD}$

20.8.8 ADPCH

Name: ADPCH  
Address: 0x09F

ADC Positive Channel Selection Register



**Bits 5:0 – PCH[5:0]** ADC Positive Input Channel Selection bits  
See [ADC Positive Input Channel Selections](#) for input selection details.

20.8.9 ADPRE

**Name:** ADPRE  
**Address:** 0x10F

ADC Precharge Time Control Register

Bit	15	14	13	12	11	10	9	8
				PREH[4:0]				
Access				R/W	R/W	R/W	R/W	R/W
Reset				0	0	0	0	0
Bit	7	6	5	4	3	2	1	0
	PREL[7:0]							
Access	R/W	R/W	R/W	R/W	R/W	R/W	R/W	R/W
Reset	0	0	0	0	0	0	0	0

**Bits 12:8 – PREH[4:0]** Precharge Time Select bits (High Byte)

Value	Description
1 to 8191	Number of ADC clocks in the precharge time
0	Precharge time is not included in the data conversion cycle

**Bits 7:0 – PREL[7:0]** Precharge Time Select bits (Low Byte)

Value	Description
1 to 8191	Number of ADC clocks in the precharge time
0	Precharge time is not included in the data conversion cycle

**Note:** If ADPRE is not equal to '0', then ADACQ = b'00000000 means Acquisition time is 256 clocks of the selected ADC clock.

20.8.10 ADACQ

**Name:** ADACQ  
**Address:** 0x10C

ADC Acquisition Time Control Register

Bit	15	14	13	12	11	10	9	8
				ACQH[4:0]				
Access				R/W	R/W	R/W	R/W	R/W
Reset				0	0	0	0	0
Bit	7	6	5	4	3	2	1	0
	ACQL[7:0]							
Access	R/W	R/W	R/W	R/W	R/W	R/W	R/W	R/W
Reset	0	0	0	0	0	0	0	0

**Bits 12:8 – ACQH[4:0]** Acquisition (charge share time) Select bits (High Byte)

Value	Description
1 to 8191	Number of ADC clock periods in the acquisition time
0	Acquisition time is not included in the data conversion cycle <sup>(1)</sup>

**Bits 7:0 – ACQL[7:0]** Acquisition (charge share time) Select bits (Low Byte)

Value	Description
1 to 8191	Number of ADC clock periods in the acquisition time
0	Acquisition time is not included in the data conversion cycle <sup>(1)</sup>

**Note:**

1. If ADPRE is not equal to '0', then ADACQ = 0b0\_0000\_0000\_0000 means Acquisition time is 8192 clocks of the selected ADC clock.

**20.8.11 ADCAP**

**Name:** ADCAP  
**Address:** 0x10E

ADC Additional Sample Capacitor Selection Register

Bit	7	6	5	4	3	2	1	0
				CAP[4:0]				
Access				R/W	R/W	R/W	R/W	R/W
Reset				0	0	0	0	0

**Bits 4:0 – CAP[4:0]** ADC Additional Sample Capacitor Selection bits

Value	Description
1 to 31	Number of pF in the additional capacitance
0	No additional capacitance

**20.8.12 ADRPT**

**Name:** ADRPT  
**Address:** 0x09A

ADC Repeat Setting Register

Bit	7	6	5	4	3	2	1	0
	RPT[7:0]							
Access	R/W	R/W	R/W	R/W	R/W	R/W	R/W	R/W
Reset	0	0	0	0	0	0	0	0

**Bits 7:0 – RPT[7:0]** ADC Repeat Threshold bits

Determines the number of times that the ADC is triggered for a threshold check. When ADCNT reaches this value the error threshold is checked. Used when the computation mode is Low-pass Filter, Burst Average, or Average. See [Computation Modes](#) for more details.



**20.8.13 ADCNT**

**Name:** ADCNT  
**Address:** 0x099

ADC Repeat Counter Register

Bit	7	6	5	4	3	2	1	0
	CNT[7:0]							
Access	R/W	R/W	R/W	R/W	R/W	R/W	R/W	R/W
Reset	x	x	x	x	x	x	x	x

**Bits 7:0 – CNT[7:0]** ADC Repeat Count bits

Counts the number of times that the ADC is triggered before the threshold is checked. When this value reaches ADPRT then the threshold is checked. Used when the computation mode is Low-pass Filter, Burst Average, or Average. See [Computation Modes](#) for more details.

Reset States: POR/BOR = xxxxxxxx  
 All Other Resets = uuuuuuuu

**20.8.14 ADFLTR**

**Name:** ADFLTR  
**Address:** 0x094

ADC Filter Register

Bit	15	14	13	12	11	10	9	8
	FLTRH[7:0]							
Access	RO	RO	RO	RO	RO	RO	RO	RO
Reset	x	x	x	x	x	x	x	x
Bit	7	6	5	4	3	2	1	0
	FLTRL[7:0]							
Access	RO	RO	RO	RO	RO	RO	RO	RO
Reset	x	x	x	x	x	x	x	x

**Bits 15:8 – FLTRH[7:0]** ADC Filter Output Most Significant bits  
 In Accumulate, Average, and Burst Average mode, this is equal to ADACC right shifted by the **CRS** bits.  
 In LPF mode, this is the output of the low-pass filter.

**Bits 7:0 – FLTRL[7:0]** ADC Filter Output Least Significant bits  
 In Accumulate, Average, and Burst Average mode, this is equal to ADACC right shifted by the **CRS** bits.  
 In LPF mode, this is the output of the low-pass filter.

20.8.15 ADRES

**Name:** ADRES  
**Address:** 0x09D

ADC Result Register

Bit	15	14	13	12	11	10	9	8
RESH[7:0]								
Access	R/W	R/W	R/W	R/W	R/W	R/W	R/W	R/W
Reset	x	x	x	x	x	x	x	x
Bit	7	6	5	4	3	2	1	0
RESL[7:0]								
Access	R/W	R/W	R/W	R/W	R/W	R/W	R/W	R/W
Reset	x	x	x	x	x	x	x	x

**Bits 15:8 – RESH[7:0]** ADC Result Register bits. High bits  
 Reset States: POR/BOR = xxxxxxxx  
 All Other Resets = uuuuuuuu

Value	Condition	Description
0x00 to 0x0F	FRM = 1	Upper 4 bits of result
0x00 to 0xFF	FRM = 0	Upper 8 bits of result

**Bits 7:0 – RESL[7:0]** ADC Result Register bits. Lower bits  
 Reset States: POR/BOR = xxxxxxxx  
 All Other Resets = uuuuuuuu

Value	Condition	Description
0x00 to 0xFF	FRM = 1	Lower 8 bits of result
0x00, 0x10 to 0xF0	FRM = 0	Lower 4 bits of result

**20.8.16 ADPREV**

**Name:** ADPREV  
**Address:** 0x09B

ADC Previous Result Register

Bit	15	14	13	12	11	10	9	8
	PREVH[7:0]							
Access	RO	RO	RO	RO	RO	RO	RO	RO
Reset	x	x	x	x	x	x	x	x
Bit	7	6	5	4	3	2	1	0
	PREVL[7:0]							
Access	RO	RO	RO	RO	RO	RO	RO	RO
Reset	x	x	x	x	x	x	x	x

**Bits 15:8 – PREVH[7:0]** Previous ADC Result Most Significant bits

Value	Condition	Description
0 to 0xFF	PSIS = 1	Upper byte of ADFLTR at the start of current ADC conversion
varies	PSIS = 0	Upper bits of ADRES at the start of current ADC conversion <sup>(1)</sup>

**Bits 7:0 – PREVL[7:0]** Previous ADC Result Least Significant bits

Value	Condition	Description
0 to 0xFF	PSIS = 1	Lower byte of ADFLTR at the start of current ADC conversion
varies	PSIS = 0	Lower bits of ADRES at the start of current ADC conversion <sup>(1)</sup>

**Note:** If PSIS = 0, PREVH and PREVL are formatted the same way as ADRES is, depending on the FRM bit.

20.8.17 ADACC

**Name:** ADACC  
**Address:** 0x096

ADC Accumulator Register  
 See [Computation Modes](#) for more details.

Bit	23	22	21	20	19	18	17	16
							ACCU[1:0]	
Access							R/W	R/W
Reset							x	x
Bit	15	14	13	12	11	10	9	8
	ACCH[7:0]							
Access	R/W	R/W	R/W	R/W	R/W	R/W	R/W	R/W
Reset	x	x	x	x	x	x	x	x
Bit	7	6	5	4	3	2	1	0
	ACCL[7:0]							
Access	R/W	R/W	R/W	R/W	R/W	R/W	R/W	R/W
Reset	x	x	x	x	x	x	x	x

**Bits 17:16 – ACCU[1:0]**  
 ADC Accumulator MSB. Upper two bits of accumulator value.

**Bits 15:8 – ACCH[7:0]**  
 ADC Accumulator middle bits. Higher eight bits of accumulator value.

**Bits 7:0 – ACCL[7:0]**  
 ADC Accumulator LSB. Lower eight bits of accumulator value.

**20.8.18 ADSTPT**

**Name:** ADSTPT  
**Address:** 0x092

ADC Threshold Setpoint Register

Depending on the CALC bits, it may be used to determine ADERR. See [ADC Error Calculation Mode](#) for more details.

Bit	15	14	13	12	11	10	9	8
	STPTH[7:0]							
Access	R/W	R/W	R/W	R/W	R/W	R/W	R/W	R/W
Reset	0	0	0	0	0	0	0	0
Bit	7	6	5	4	3	2	1	0
	STPTL[7:0]							
Access	R/W	R/W	R/W	R/W	R/W	R/W	R/W	R/W
Reset	0	0	0	0	0	0	0	0

**Bits 15:8 – STPTH[7:0]**

ADC Threshold Setpoint Most Significant Byte.

**Bits 7:0 – STPTL[7:0]**

ADC Threshold Setpoint Least Significant Byte.

**20.8.19 ADERR**

**Name:** ADERR  
**Address:** 0x090

ADC Setpoint Error Register

	Bit	15	14	13	12	11	10	9	8
		ERRH[7:0]							
Access		RO	RO	RO	RO	RO	RO	RO	RO
Reset		x	x	x	x	x	x	x	x
	Bit	7	6	5	4	3	2	1	0
		ADERRL[7:0]							
Access		RO	RO	RO	RO	RO	RO	RO	RO
Reset		x	x	x	x	x	x	x	x

**Bits 15:8 – ERRH[7:0]**

ADC Setpoint Error MSB. Upper byte of ADC Setpoint Error calculation is determined by [CALC](#) bits.

**Bits 7:0 – ADERRL[7:0]**

ADC Setpoint Error LSB. Lower byte of ADC Setpoint Error calculation is determined by [CALC](#) bits.

**20.8.20 ADLTH**

**Name:** ADLTH  
**Address:** 0x08C

ADC Lower Threshold Register

ADLTH and ADUTH are compared with ADERR to set the **UTHR** and **LTHR** bits. Depending on the setting of **TMD**, an interrupt may be triggered by the results of this comparison.

Bit	15	14	13	12	11	10	9	8
	LTHH[7:0]							
Access	R/W	R/W	R/W	R/W	R/W	R/W	R/W	R/W
Reset	0	0	0	0	0	0	0	0
Bit	7	6	5	4	3	2	1	0
	LTHL[7:0]							
Access	R/W	R/W	R/W	R/W	R/W	R/W	R/W	R/W
Reset	0	0	0	0	0	0	0	0

**Bits 15:8 – LTHH[7:0]** ADC Lower Threshold MSB.

**Bits 7:0 – LTHL[7:0]** ADC Lower Threshold LSB.



**20.8.21 ADUTH**

**Name:** ADUTH  
**Address:** 0x08E

ADC Upper Threshold Register

ADLTH and ADUTH are compared with ADERR to set the **UTHR** and **LTHR** bits. Depending on the setting of **TMD**, an interrupt may be triggered by the results of this comparison.

Bit	15	14	13	12	11	10	9	8
	UTHH[7:0]							
Access	R/W	R/W	R/W	R/W	R/W	R/W	R/W	R/W
Reset	0	0	0	0	0	0	0	0
Bit	7	6	5	4	3	2	1	0
	UTHL[7:0]							
Access	R/W	R/W	R/W	R/W	R/W	R/W	R/W	R/W
Reset	0	0	0	0	0	0	0	0

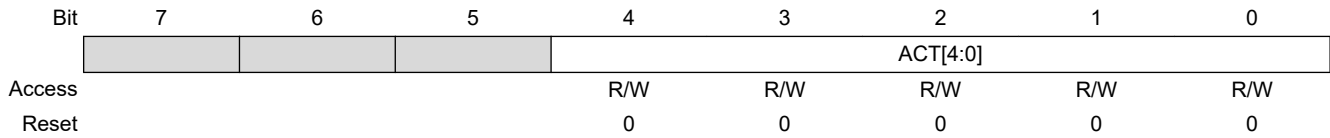
**Bits 15:8 – UTHH[7:0]** ADC Upper Threshold MSB.

**Bits 7:0 – UTHL[7:0]** ADC Upper Threshold LSB.

20.8.22 ADACT

**Name:** ADACT  
**Address:** 0x117

ADC AUTO Conversion Trigger Source Selection Register



**Bits 4:0 – ACT[4:0]** Auto-Conversion Trigger Select Bits

Value	Description
00000 to 11111	See <a href="#">ADC Auto-Conversion Trigger Sources</a> table.

**20.8.23 ADCPCON0**

**Name:** ADCPCON0  
**Address:** 0x29F

ADC Charge Pump Control Register 0

	7		6		5		4		3		2		1		0
	CPON														CPRDY
Access	R/W														RO
Reset	0														0

**Bit 7 – CPON** Charge Pump On Control bit

Value	Description
1	Charge Pump On when requested by the ADC
0	Charge Pump Off

**Bit 0 – CPRDY** Charge Pump Ready Status bit

Value	Description
1	Charge Pump is ready
0	Charge Pump is not ready (or never started)

## 21. (DAC) 5-Bit Digital-to-Analog Converter Module

The Digital-to-Analog Converter supplies a variable voltage reference, ratiometric with the input source, with 32 selectable output levels.

The positive input source ( $V_{SOURCE+}$ ) of the DAC can be connected to:

- FVR Buffer
- External  $V_{REF+}$  pin
- $V_{DD}$  supply voltage

The negative input source ( $V_{SOURCE-}$ ) of the DAC can be connected to:

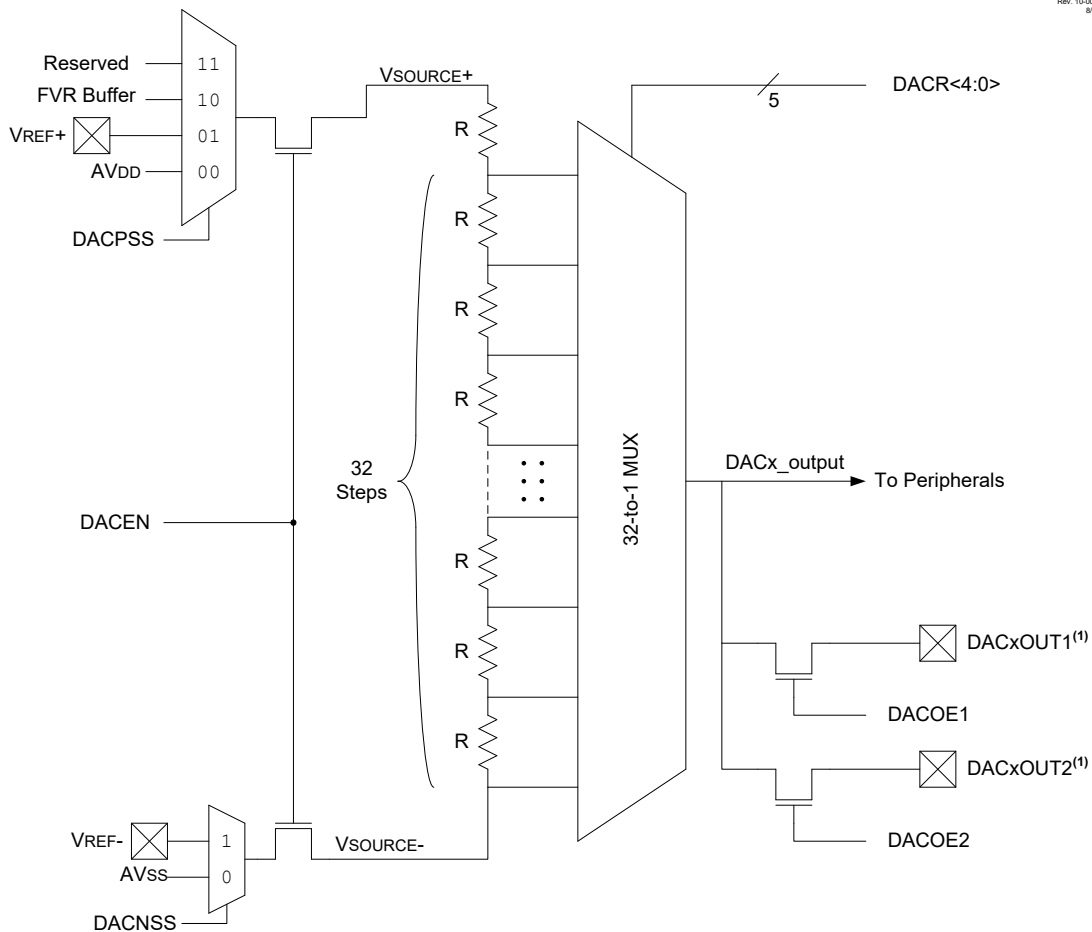
- External  $V_{REF-}$  pin
- $V_{SS}$

The output of the DAC (DACx\_output) can be selected as a reference voltage to the following:

- Comparator positive input
- ADC input channel
- DACxOUT1 pin
- DACxOUT2 pin

The Digital-to-Analog Converter (DAC) can be enabled by setting the [EN](#) bit.

**Figure 21-1. Digital-to-Analog Converter Block Diagram**



**Note:**

1. The unbuffered  $DACx\_output$  is provided on the  $DACxOUT$  pin(s).

### 21.1 Output Voltage Selection

The DAC has 32 voltage level ranges. The 32 levels are set with the  $DAC1R$  bits.

The DAC output voltage can be determined by using the following equation.

**Equation 21-1. DAC Output Voltage**

When  $EN = 1$ :

$$DACx\_output = \left( \left( V_{REF+} - V_{REF-} \right) \times \frac{DACR[4:0]}{2^5} \right) + V_{REF-}$$

**Note:** See the  $DAC1CON0$  register for the available  $V_{SOURCE+}$  and  $V_{SOURCE-}$  selections.

## 21.2 Ratiometric Output Level

The DAC output value is derived using a resistor ladder with each end of the ladder tied to a positive and negative voltage reference input source. If the voltage of either input source fluctuates, a similar fluctuation will result in the DAC output value.

The value of the individual resistors within the ladder can be found in the “5-Bit DAC Specifications” table from the “Electrical Specifications” chapter.

### Related Links

[42.4.10 5-Bit DAC Specifications](#)

## 21.3 DAC Voltage Reference Output

The unbuffered DAC voltage can be output to the DACxOUTn pin(s) by setting the respective [OEn](#) bit(s). Selecting the DAC reference voltage for output on either DACxOUTn pin automatically overrides the digital output buffer, the weak pull-up and digital input threshold detector functions of that pin.

Reading the DACxOUTn pin when it has been configured for DAC reference voltage output will always return a ‘0’.



**Important:** The unbuffered DAC output (DACxOUTn) is not intended to drive an external load.

---

## 21.4 Operation During Sleep

When the device wakes up from Sleep through an interrupt or a Windowed Watchdog Timer Time-out, the contents of the DACxCON0 register are not affected. To minimize current consumption in Sleep mode, the voltage reference should be disabled.

## 21.5 Effects of a Reset

A device Reset affects the following:

- DACx is disabled.
- DACx output voltage is removed from the DACxOUTn pin(s).
- The [DAC1R](#) range select bits are cleared.

## 21.6 Register Summary - DAC Control

Address	Name	Bit Pos.							
0x090E	<a href="#">DAC1CON0</a>	7:0	EN		OE1	OE2	PSS[1:0]		NSS
0x090F	<a href="#">DAC1CON1</a>	7:0					DAC1R[4:0]		

## 21.7 Register Definitions: DAC Control

Long bit name prefixes for the DAC are shown in the table below. Refer to the *"Long Bit Names Section"* for more information.

**Table 21-1. DAC Long Bit Name Prefixes**

Peripheral	Bit Name Prefix
DAC	DAC

### Related Links

[1.4.2.2 Long Bit Names](#)

**21.7.1 DAC1CON0**

**Name:** DAC1CON0  
**Address:** 0x90E

DAC Control Register

Bit	7	6	5	4	3	2	1	0
	EN		OE1	OE2	PSS[1:0]			NSS
Access	R/W		R/W	R/W	R/W	R/W		R/W
Reset	0		0	0	0	0		0

**Bit 7 – EN** DAC Enable bit

Value	Description
1	DAC is enabled
0	DAC is disabled

**Bit 5 – OE1** DAC Voltage Output Enable bit

Value	Description
1	DAC voltage level is output on the DAC1OUT1 pin
0	DAC voltage level is disconnected from the DAC1OUT1 pin

**Bit 4 – OE2** DAC Voltage Output Enable bit

Value	Description
1	DAC voltage level is output on the DAC1OUT2 pin
0	DAC voltage level is disconnected from the DAC1OUT2 pin

**Bits 3:2 – PSS[1:0]** DAC Positive Source Select bit

Value	Description
11	Reserved
10	FVR buffer
01	V <sub>REF+</sub>
00	AV <sub>DD</sub>

**Bit 0 – NSS** DAC Negative Source Select bit

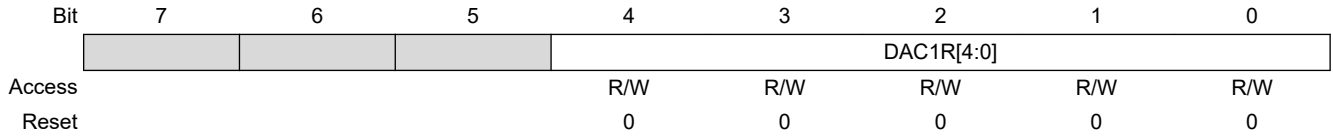
Value	Description
1	V <sub>REF-</sub>
0	AV <sub>SS</sub>



**21.7.2 DAC1CON1**

**Name:** DAC1CON1  
**Address:** 0x90F

DAC Data Register



**Bits 4:0 – DAC1R[4:0]** Data Input Register for DAC bits

## 22. Numerically Controlled Oscillator (NCO) Module

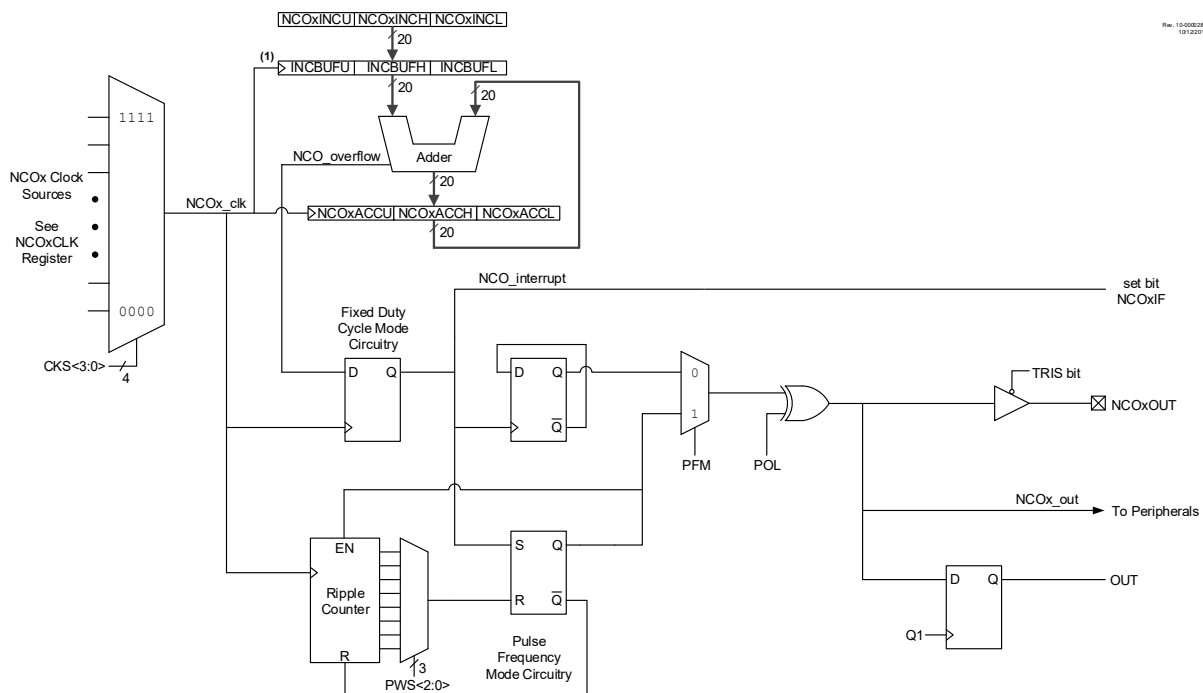
The Numerically Controlled Oscillator (NCO) module is a timer that uses overflow from the addition of an increment value to divide the input frequency. The advantage of the addition method over simple counter driven timer is that the output frequency resolution does not vary with the divider value. The NCO is most useful for application that requires frequency accuracy and fine resolution at a fixed duty cycle.

Features of the NCO include:

- 20-bit Increment Function
- Fixed Duty Cycle mode (FDC) mode
- Pulse Frequency (PF) mode
- Output Pulse Width Control
- Multiple Clock Input Sources
- Output polarity Control
- Interrupt Capability

The following figure is a simplified block diagram of the NCO module.

**Figure 22-1. Numerically Controlled Oscillator Module Simplified Block Diagram**



**Note:**

1. The increment registers are double-buffered to allow for value changes to be made without first disabling the NCO module. The full increment value is loaded into the buffer registers on the second rising edge of the NCOx\_clk signal that occurs immediately after a write to NCOxINCL register. The buffers are not user-accessible and are shown here for reference.

## 22.1 NCO Operation

The NCO operates by repeatedly adding a fixed value to an accumulator. Additions occur at the input clock rate. The accumulator will overflow with a carry periodically, which is the raw NCO output (NCO\_overflow). This effectively reduces the input clock by the ratio of the addition value to the maximum accumulator value. See the following equation.

### Equation 22-1. NCO Overflow Frequency

$$F_{OVERFLOW} = \frac{NCO\ Clock\ Frequency \times\ Increment\ Value}{2^{20}}$$

### 22.1.1 NCO Clock Sources

Clock sources available to the NCO are shown in the following table:

**Table 22-1. NCO Clock Sources**

CKS	Clock Source
1111-1011	Reserved
1010	CLC4_out
1001	CLC3_out
1000	CLC2_out
0111	CLC1_out
0110	CLKR
0101	SOSC
0100	MFINTOSC (32 kHz)
0011	MFINTOSC (500 kHz)
0010	LFINTOSC
0001	HFINTOSC
0000	F <sub>OSC</sub>

The NCO clock source is selected by configuring the [CKS](#) bits.

#### Related Links

[22.9.2 NCOxCLK](#)

### 22.1.2 Accumulator

The accumulator is a 20-bit register. Read and write access to the accumulator is available through three registers:

- NCOxACCL
- NCOxACCH
- NCOxACCU

#### Related Links

[22.9.3 NCOxACC](#)

### 22.1.3 Adder

The NCO Adder is a full adder, which operates synchronously from the source clock. The addition of the previous result and the increment value replaces the accumulator value on the rising edge of each input clock.

### 22.1.4 Increment Registers

The increment value is stored in three registers making up a 20-bit incrementer. In order of LSB to MSB they are:

- NCOxINCL
- NCOxINCH
- NCOxINCW

When the NCO module is enabled, the NCOxINCW and NCOxINCH registers should be written first, then the NCOxINCL register. Writing to the NCOxINCL register initiates the increment buffer registers to be loaded simultaneously on the second rising edge of the NCO\_clk signal.

The registers are readable and writable. The increment registers are double-buffered to allow value changes to be made without first disabling the NCO module.

When the NCO module is disabled, the increment buffers are loaded immediately after a write to the increment registers.



**Important:** The increment buffer registers are not user-accessible.

---

#### Related Links

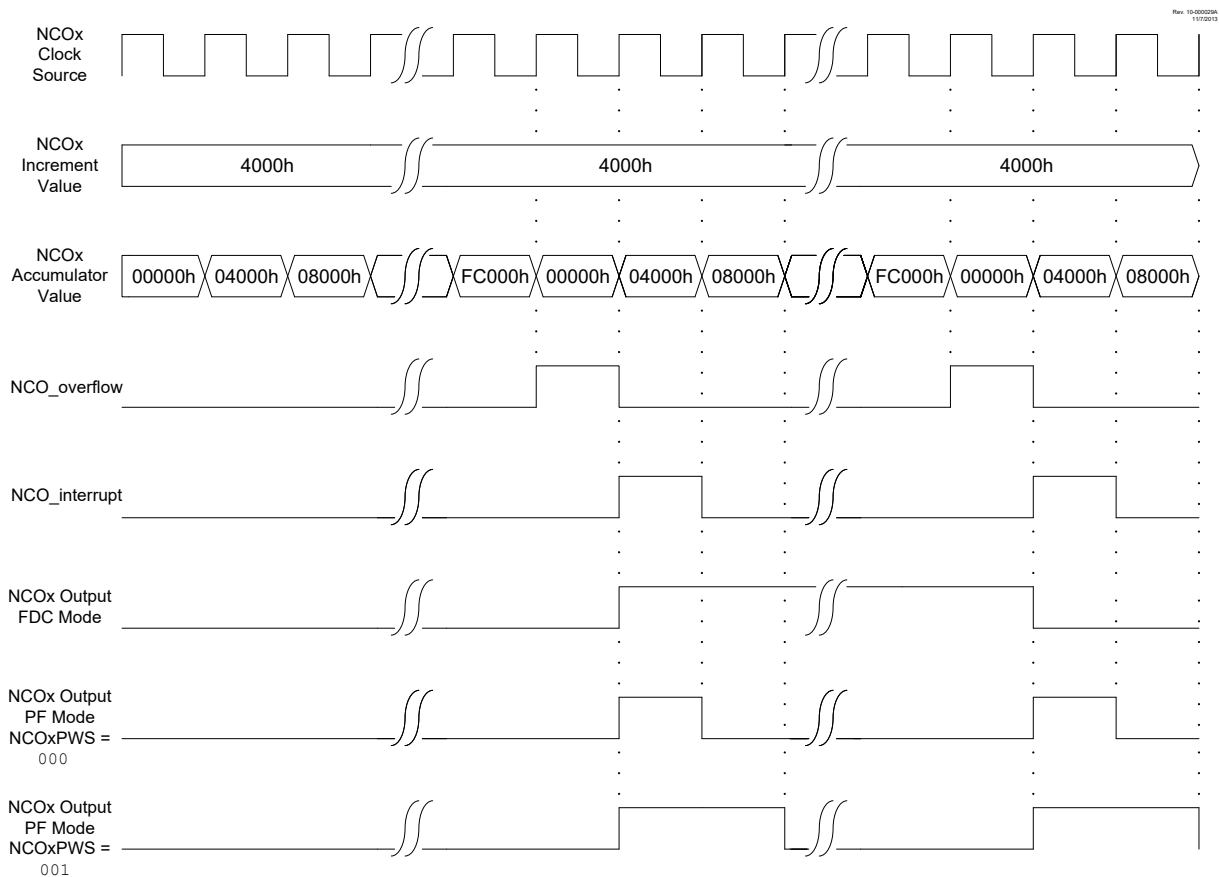
[22.9.4 NCOxINC](#)

## 22.2 Fixed Duty Cycle Mode

In Fixed Duty Cycle (FDC) mode, every time the accumulator overflows (NCO\_overflow), the output is toggled at a frequency rate half of the  $F_{\text{OVERFLOW}}$ . This provides a 50% duty cycle, provided that the increment value remains constant. For more information, see the figure below.

The FDC mode is selected by clearing the [PFM](#) bit.

**Figure 22-2. FDC Output Mode Operation Diagram**



**Related Links**

[22.9.1 NCOxCON](#)

**22.3 Pulse Frequency Mode**

In Pulse Frequency (PF) mode, every time the Accumulator overflows, the output becomes active for one or more clock periods. Once the clock period expires, the output returns to an inactive state. This provides a pulsed output. The output becomes active on the rising clock edge immediately following the overflow event. For more information, see the figure above.

The value of the active and inactive states depends on the [POL](#) bit.

The PF mode is selected by setting the [PFM](#) bit.

**Related Links**

[22.9.1 NCOxCON](#)

**22.3.1 Output Pulse Width Control**

When operating in PF mode, the active state of the output can vary in width by multiple clock periods. Various pulse widths are selected with the [PWS](#) bits.

When the selected pulse width is greater than the Accumulator overflow time frame, then NCO output does not toggle.

**Related Links**

[22.9.2 NCOxCLK](#)

## 22.4 Output Polarity Control

The last stage in the NCO module is the output polarity. The [POL](#) bit selects the output polarity. Changing the polarity while the interrupts are enabled will cause an interrupt for the resulting output transition.

The NCO output signal (NCOx\_out) is available to the following peripherals:

- CLC
- CWG
- Timer1
- Timer2
- CLKR

## 22.5 Interrupts

When the accumulator overflows (NCO\_overflow), the NCO Interrupt Flag bit, NCO1IF, of the PIR7 register is set. To enable the interrupt event (NCO\_interrupt), the following bits must be set:

- [EN](#) bit
- NCO1IE bit of the PIE7 register
- PEIE bit of the INTCON register
- GIE bit of the INTCON register

The interrupt must be cleared by software by clearing the NCO1IF bit in the Interrupt Service Routine.

**Related Links**

[22.9.1 NCOxCON](#)

[7.8.10 INTCON](#)

## 22.6 Effects of a Reset

All of the NCO registers are cleared to zero as the result of a Reset.

## 22.7 Operation in Sleep

The NCO module operates independently from the system clock and will continue to run during Sleep, provided that the clock source selected remains active.

The HFINTOSC remains active during Sleep when the NCO module is enabled and the HFINTOSC is selected as the clock source, regardless of the system clock source selected.

In other words, if the HFINTOSC is simultaneously selected as the system clock and the NCO clock source, when the NCO is enabled, the CPU will go idle during Sleep, but the NCO will continue to operate and the HFINTOSC will remain active.

This will have a direct effect on the Sleep mode current.

## 22.8 Register Summary - NCO

Address	Name	Bit Pos.							
0x058C	NCO1ACC	7:0	ACCL[7:0]						
		15:8	ACCH[7:0]						
		23:16							ACCU[3:0]
0x058F	NCO1INC	7:0	INCL[7:0]						
		15:8	INCH[7:0]						
		23:16							INCU[3:0]
0x0592	NCO1CON	7:0	EN		OUT	POL			PFM
0x0593	NCO1CLK	7:0	PWS[2:0]				CKS[3:0]		

## 22.9 Register Definitions: NCO

Long bit name prefixes for the NCO peripherals are shown in the table below. Refer to the *"Long Bit Names Section"* for more information.

**Table 22-2. NCO Long Bit Name Prefixes**

Peripheral	Bit Name Prefix
NCO	NCO

### Related Links

[1.4.2.2 Long Bit Names](#)

**22.9.1 NCOxCON**

**Name:** NCOxCON  
**Address:** 0x0592

NCO Control Register

Bit	7	6	5	4	3	2	1	0
	EN		OUT	POL				PFM
Access	R/W		RO	R/W				R/W
Reset	0		0	0				0

**Bit 7 – EN** NCO Enable bit

Value	Description
1	NCO module is enabled
0	NCO module is disabled

**Bit 5 – OUT** NCO Output bit  
 Displays the current output value of the NCO module.

**Bit 4 – POL** NCO Polarity bit

Value	Description
1	NCO output signal is inverted
0	NCO output signal is not inverted

**Bit 0 – PFM** NCO Pulse Frequency Mode bit

Value	Description
1	NCO operates in Pulse Frequency mode
0	NCO operates in Fixed Duty Cycle mode, divide by 2



# PIC16(L)F18455/56

## Numerically Controlled Oscillator (NCO) Module

### 22.9.2 NCOxCLK

**Name:** NCOxCLK  
**Address:** 0x0593

NCO Input Clock Control Register

Bit	7	6	5	4	3	2	1	0
	PWS[2:0]				CKS[3:0]			
Access	R/W	R/W	R/W		R/W	R/W	R/W	R/W
Reset	0	0	0		0	0	0	0

**Bits 7:5 – PWS[2:0]** NCO Output Pulse Width Select bits<sup>(1)</sup>

Value	Description
111	NCO output is active for 128 input clock periods
110	NCO output is active for 64 input clock periods
101	NCO output is active for 32 input clock periods
100	NCO output is active for 16 input clock periods
011	NCO output is active for 8 input clock periods
010	NCO output is active for 4 input clock periods
001	NCO output is active for 2 input clock periods
000	NCO output is active for 1 input clock periods

**Bits 3:0 – CKS[3:0]** NCO Clock Source Select bits  
 CKS values are available in the [NCO Clock Sources](#) table.

**Note:**

1. PWS applies only when operating in Pulse Frequency mode.

# PIC16(L)F18455/56

## Numerically Controlled Oscillator (NCO) Module

### 22.9.3 NCOxACC

**Name:** NCOxACC  
**Address:** 0x058C

NCO Accumulator Register

Bit	23	22	21	20	19	18	17	16
	ACCU[3:0]							
Access					R/W	R/W	R/W	R/W
Reset					0	0	0	0
Bit	15	14	13	12	11	10	9	8
	ACCH[7:0]							
Access	R/W	R/W	R/W	R/W	R/W	R/W	R/W	R/W
Reset	0	0	0	0	0	0	0	0
Bit	7	6	5	4	3	2	1	0
	ACCL[7:0]							
Access	R/W	R/W	R/W	R/W	R/W	R/W	R/W	R/W
Reset	0	0	0	0	0	0	0	0

**Bits 19:16 – ACCU[3:0]** NCO Accumulator – Upper Byte<sup>(1)</sup>

**Bits 15:8 – ACCH[7:0]** NCO Accumulator – High Byte

**Bits 7:0 – ACCL[7:0]** NCO Accumulator – Low Byte

**Note:**

1. The accumulator spans registers NCOxACCU:NCOxACCH: NCOxACCL. The 24 bits are reserved but not all are used. This register updates in real-time, asynchronously to the CPU; there is no provision to ensure atomic access to this 24-bit space using an 8-bit bus. Writing to this register while the module is operating will produce undefined results.

# PIC16(L)F18455/56

## Numerically Controlled Oscillator (NCO) Module

### 22.9.4 NCOxINC

**Name:** NCOxINC  
**Address:** 0x058F

NCO Increment Register

Bit	23	22	21	20	19	18	17	16
					INCUI[3:0]			
Access					R/W	R/W	R/W	R/W
Reset					0	0	0	0
Bit	15	14	13	12	11	10	9	8
	INCHI[7:0]							
Access	R/W	R/W	R/W	R/W	R/W	R/W	R/W	R/W
Reset	0	0	0	0	0	0	0	0
Bit	7	6	5	4	3	2	1	0
	INCLI[7:0]							
Access	R/W	R/W	R/W	R/W	R/W	R/W	R/W	R/W
Reset	0	0	0	0	0	0	0	0

**Bits 19:16 – INCUI[3:0]** NCO Increment – Upper Byte<sup>(1)</sup>

**Bits 15:8 – INCHI[7:0]** NCO Increment – High Byte<sup>(1)</sup>

**Bits 7:0 – INCLI[7:0]** NCO Increment – Low Byte<sup>(1,2)</sup>

**Note:**

1. The logical increment spans NCOxINCUI:NCOxINCHI:NCOxINCLI.
2. NCOxINC is double-buffered as INCBUF; INCBUF is updated on the next falling edge of NCOxCLK after writing to NCOxINCLI; NCOxINCUI and NCOxINCHI should be written prior to writing NCOxINCLI.

## 23. (CMP) Comparator Module

Comparators are used to interface analog circuits to a digital circuit by comparing two analog voltages and providing a digital indication of their relative magnitudes. Comparators are very useful mixed-signal building blocks because they provide analog functionality independent of program execution. The PIC16(L)F18455/56 devices have 2 comparators (C1/C2).

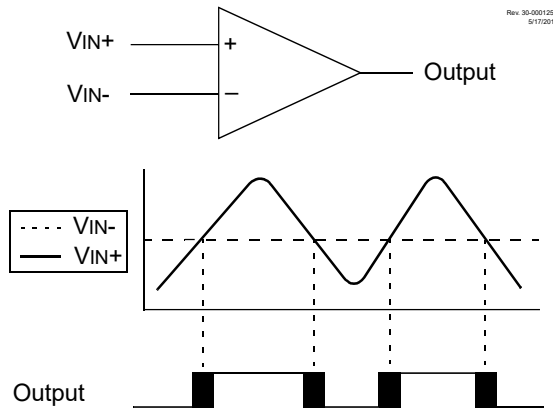
The analog comparator module includes the following features:

- Programmable Input Selection
- Programmable Output Polarity
- Rising/Falling Output Edge Interrupts
- Wake-up from Sleep
- CWG Auto-shutdown Source
- Selectable Voltage Reference
- ADC Auto-Trigger
- Odd Numbered Timers (Timer1, Timer3, etc.) Gate
- Even Numbered Timers (Timer2, Timer4, etc.) Reset
- CCP Capture Mode Input
- DSM Modulator Source
- Input and Window Signal-to-Signal Measurement Timer

### 23.1 Comparator Overview

A single comparator is shown in [Figure 23-1](#) along with the relationship between the analog input levels and the digital output. When the analog voltage at  $V_{IN+}$  is less than the analog voltage at  $V_{IN-}$ , the output of the comparator is a digital low level. When the analog voltage at  $V_{IN+}$  is greater than the analog voltage at  $V_{IN-}$ , the output of the comparator is a digital high level.

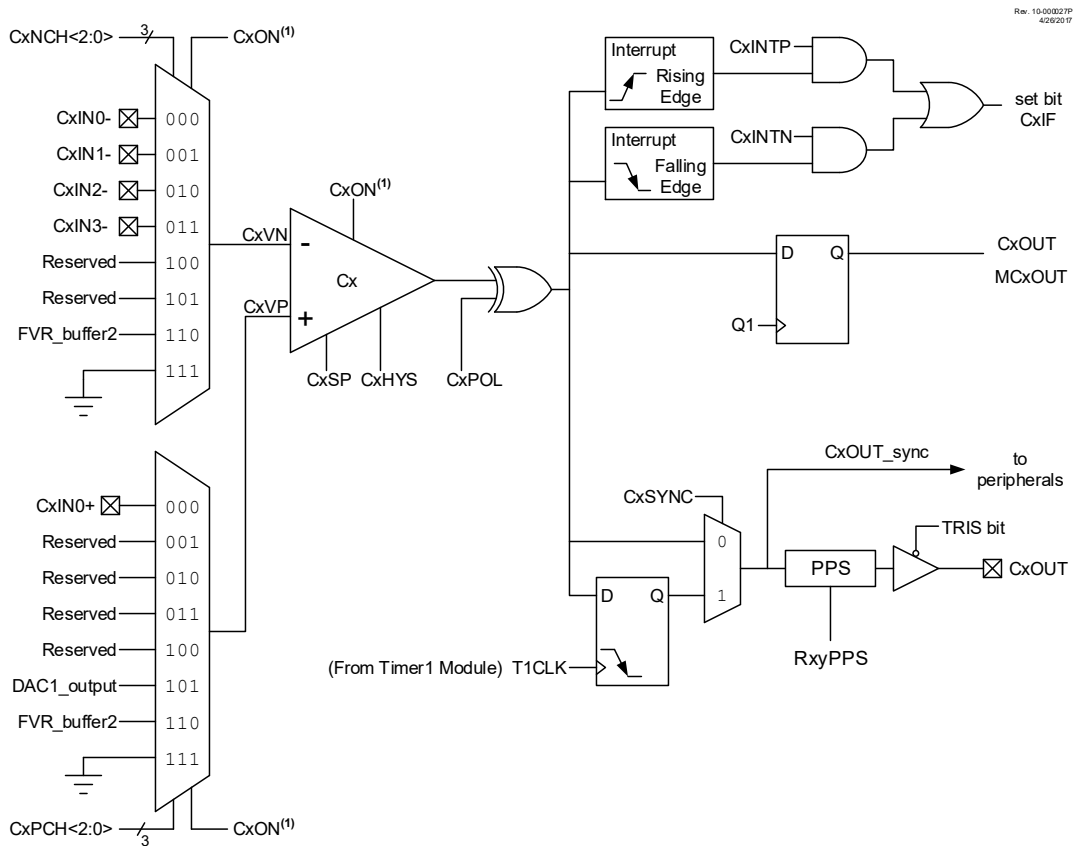
**Figure 23-1. Single Comparator**



**Note:**

1. The black areas of the output of the comparator represent the uncertainty due to input offsets and response time.

**Figure 23-2. Comparator Module Simplified Block Diagram**



**Related Links**

- [23.15.3 CMxNCH](#)
- [23.15.4 CMxPCH](#)

**23.2 Comparator Control**

Each comparator has two control registers: CMxCON0 and CMxCON1.

The **CMxCON0** register contains Control and Status bits for the following:

- Enable
- Output
- Output Polarity
- Hysteresis Enable
- Timer1 Output Synchronization

The **CMxCON1** register contains Control bits for the following:

- Interrupt on Positive/Negative Edge Enables
- Positive Input Channel Selection
- Negative Input Channel Selection

### 23.2.1 Comparator Enable

Setting the [EN](#) bit enables the comparator for operation. Clearing the [CxEN](#) bit disables the comparator, resulting in minimum current consumption.

### 23.2.2 Comparator Output

The output of the comparator can be monitored by reading either the [CxOUT](#) bit or the [MCxOUT](#) bit.

The comparator output can also be routed to an external pin through the [RxyPPS](#) register. The corresponding TRIS bit must be clear to enable the pin as an output.

**Note:**

1. The internal output of the comparator is latched with each instruction cycle. Unless otherwise specified, external outputs are not latched.

**Related Links**

[15.9.2 RxyPPS](#)

### 23.2.3 Comparator Output Polarity

Inverting the output of the comparator is functionally equivalent to swapping the comparator inputs. The polarity of the comparator output can be inverted by setting the [CxPOL](#) bit. Clearing the [CxPOL](#) bit results in a non-inverted output.

[Table 23-1](#) shows the output state versus input conditions, including polarity control.

**Table 23-1. Comparator Output State vs. Input Conditions**

Input Condition	CxPOL	CxOUT
$CxVn > CxVp$	0	0
$CxVn < CxVp$	0	1
$CxVn > CxVp$	1	1
$CxVn < CxVp$	1	0

### 23.3 Comparator Hysteresis

A selectable amount of separation voltage can be added to the input pins of each comparator to provide a hysteresis function to the overall operation. Hysteresis is enabled by setting the [CxHYS](#) bit.

See Comparator Specifications for more information.

**Related Links**

[42.4.9 Comparator Specifications](#)

### 23.4 Operation With Timer1 Gate

The output resulting from a comparator operation can be used as a source for gate control of the odd numbered timers (Timer1, Timer3, etc.). See the timer gate section for more information. This feature is useful for timing the duration or interval of an analog event.

It is recommended that the comparator output be synchronized to the timer by setting the [SYNC](#) bit. This ensures that the timer does not increment while a change in the comparator is occurring. However,

synchronization is only possible with the Timer1 clock source. Synchronization with the other odd numbered timers is only possible when they use the same clock source as Timer1.

**Related Links**

[26.7 Timer1 Gate](#)

**23.4.1 Comparator Output Synchronization**

The output from a comparator can be synchronized with Timer1 by setting the [SYNC](#) bit.

Once enabled, the comparator output is latched on the falling edge of the Timer1 source clock. If a prescaler is used with Timer1, the comparator output is latched after the prescaling function. To prevent a race condition, the comparator output is latched on the falling edge of the Timer1 clock source and Timer1 increments on the rising edge of its clock source. See the [Figure 23-2 Comparator Block Diagram](#) and the [Timer1 Block Diagram](#) for more information.

**Related Links**

[26. Timer1 Module with Gate Control](#)

**23.5 Comparator Interrupt**

An interrupt can be generated upon a change in the output value of the comparator for each comparator; a rising edge detector and a falling edge detector are present.

When either edge detector is triggered and its associated enable bit is set ([CxINTP](#) and/or [CxINTN](#) bits), the Corresponding Interrupt Flag bit (CxIF bit of the PIR2 register) will be set.

To enable the interrupt, the following bits must be set:

- [EN](#) and [POL](#) bits
- CxIE bit of the PIE2 register
- [INTP](#) bit (for a rising edge detection)
- [INTN](#) bit (for a falling edge detection)
- PEIE and GIE bits of the INTCON register

The associated interrupt flag bit, CxIF bit of the PIR2 register, must be cleared in software. If another edge is detected while this flag is being cleared, the flag will still be set at the end of the sequence.



**Important:** Although a comparator is disabled, an interrupt can be generated by changing the output polarity with the [CxPOL](#) bit, or by switching the comparator on or off with the [CxEN](#) bit.

**23.6 Comparator Positive Input Selection**

Configuring the [PCH](#) bits direct an internal voltage reference or an analog pin to the non-inverting input of the comparator:

PCH	Positive Input Source
111	CxV <sub>P</sub> connects to V <sub>SS</sub>
110	CxV <sub>P</sub> connects to FVR Buffer 2

PCH	Positive Input Source
101	CxV <sub>P</sub> connects to DAC1 output
100	CxV <sub>P</sub> not connected
011	CxV <sub>P</sub> not connected
010	CxV <sub>P</sub> not connected
001	CxV <sub>P</sub> connects to CxIN1+ pin
000	CxV <sub>P</sub> connects to CxIN0+ pin



**Important:** To use CxINy+ pins as analog input, the appropriate bits must be set in the ANSEL register and the corresponding TRIS bits must also be set to disable the output drivers.

See Fixed Voltage Reference (FVR) for more information on the Fixed Voltage Reference module.  
 See 5-Bit Digital-to-Analog Converter (DAC) module for more information on the DAC input signal.  
 Any time the comparator is disabled (CxEN = 0), all comparator inputs are disabled.

**Related Links**

- 18. [\(FVR\) Fixed Voltage Reference](#)
- 21. [\(DAC\) 5-Bit Digital-to-Analog Converter Module](#)

### 23.7 Comparator Negative Input Selection

The NCH bits direct an analog input pin and internal reference voltage or analog ground to the inverting input of the comparator:

NCH	Negative Input Sources
111	CxV <sub>N</sub> connects to AV <sub>SS</sub>
110	CxV <sub>N</sub> connects to FVR Buffer 2
101	CxV <sub>N</sub> not connected
100	CxV <sub>N</sub> not connected
011	CxV <sub>N</sub> connects to CxIN3- pin
010	CxV <sub>N</sub> connects to CxIN2- pin
001	CxV <sub>N</sub> connects to CxIN1- pin
000	CxV <sub>N</sub> connects to CxIN0- pin



**Important:** To use CxINy- pins as analog input, the appropriate bits must be set in the ANSEL register and the corresponding TRIS bits must also be set to disable the output drivers.



## 23.8 Comparator Response Time

The comparator output is indeterminate for a period of time after the change of an input source or the selection of a new reference voltage. This period is referred to as the response time. The response time of the comparator differs from the settling time of the voltage reference. Therefore, both of these times must be considered when determining the total response time to a comparator input change. See the Comparator and Voltage Reference Specifications in Comparator Specifications and Fixed Voltage Reference (FVR) Specifications for more details.

### Related Links

[42.4.9 Comparator Specifications](#)

[42.4.11 Fixed Voltage Reference \(FVR\) Specifications](#)

## 23.9 Analog Input Connection Considerations

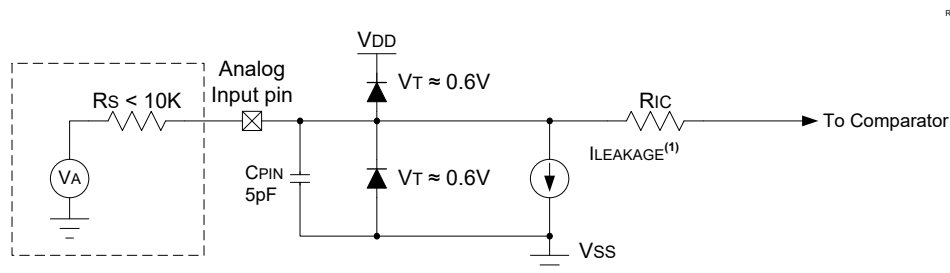
A simplified circuit for an analog input is shown in [Figure 23-3](#). Since the analog input pins share their connection with a digital input, they have reverse biased ESD protection diodes to  $V_{DD}$  and  $V_{SS}$ . The analog input, therefore, must be between  $V_{SS}$  and  $V_{DD}$ . If the input voltage deviates from this range by more than 0.6V in either direction, one of the diodes is forward biased and a latch-up may occur.

A maximum source impedance of 10 k $\Omega$  is recommended for the analog sources. Also, any external component connected to an analog input pin, such as a capacitor or a Zener diode, should have very little leakage current to minimize inaccuracies introduced.

### Note:

1. When reading a PORT register, all pins configured as analog inputs will read as a '0'. Pins configured as digital inputs will convert as an analog input, according to the input specification.
2. Analog levels on any pin defined as a digital input, may cause the input buffer to consume more current than is specified.

**Figure 23-3. Analog Input Model**



<b>Legend:</b>	CPIN	= Input Capacitance
	ILEAKAGE	= Leakage Current at the pin due to various junctions
	RIC	= Interconnect Resistance
	RS	= Source Impedance
	VA	= Analog Voltage
	VT	= Threshold Voltage

**Note:** See *Electrical Specifications* chapter.

### Related Links

[42. Electrical Specifications](#)

### **23.10 CWG1 Auto-Shutdown Source**

The output of the comparator module can be used as an auto-shutdown source for the CWG1 module. When the output of the comparator is active and the corresponding WGASxE is enabled, the CWG operation will be suspended immediately.

#### **Related Links**

[31.11.1.2 External Input Source](#)

### **23.11 ADC Auto-Trigger Source**

The output of the comparator module can be used to trigger an ADC conversion. When the ADOACT register is set to trigger on a comparator output, an ADC conversion will trigger when the comparator output goes high.

### **23.12 Even Numbered Timers Reset**

The output of the comparator module can be used to reset the even numbered timers (Timer2, Timer4, etc.). When the TxERS register is appropriately set, the timer will reset when the comparator output goes high.

### **23.13 Operation in Sleep Mode**

The comparator module can operate during Sleep. The comparator clock source is based on the Timer1 clock source. If the Timer1 clock source is either the system clock ( $F_{OSC}$ ) or the instruction clock ( $F_{OSC}/4$ ), Timer1 will not operate during Sleep, and synchronized comparator outputs will not operate.

A comparator interrupt will wake the device from Sleep. The CxIE bits of the PIEx register must be set to enable comparator interrupts.

### 23.14 Register Summary - Comparator

Address	Name	Bit Pos.							
0x098F	CMOUT	7:0							MC2OUT MC1OUT
0x0990	CM1CON0	7:0	EN	OUT		POL			HYS SYNC
0x0991	CM1CON1	7:0							INTP INTN
0x0992	CM1NCH	7:0							NCH[2:0]
0x0993	CM1PCH	7:0							PCH[2:0]
0x0994	CM2CON0	7:0	EN	OUT		POL			HYS SYNC
0x0995	CM2CON1	7:0							INTP INTN
0x0996	CM2NCH	7:0							NCH[2:0]
0x0997	CM2PCH	7:0							PCH[2:0]

### 23.15 Register Definitions: Comparator Control

Long bit name prefixes for the comparator peripherals are shown in the table below. Refer to the "Long Bit Names Section" for more information.

**Table 23-2. Comparator Bit Name Prefixes**

Peripheral	Bit Name Prefix
C1	C1
C2	C2

#### Related Links

[1.4.2.2 Long Bit Names](#)

**23.15.1 CMxCON0**

**Name:** CMxCON0  
**Address:** 0x990,0x994

Comparator x Control Register 0

Bit	7	6	5	4	3	2	1	0
	EN	OUT		POL			HYS	SYNC
Access	R/W	RO		R/W			R/W	R/W
Reset	0	0		0			0	0

**Bit 7 – EN** Comparator Enable bit

Value	Description
1	Comparator is enabled
0	Comparator is disabled and consumes no active power

**Bit 6 – OUT** Comparator Output bit

Value	Condition	Description
1	If <b>POL</b> = 0 (non-inverted polarity):	CxVP > CxVN
0	If <b>POL</b> = 0 (non-inverted polarity):	CxVP < CxVN
1	If <b>POL</b> = 1 (inverted polarity):	CxVP < CxVN
0	If <b>POL</b> = 1 (inverted polarity):	CxVP > CxVN

**Bit 4 – POL** Comparator Output Polarity Select bit

Value	Description
1	Comparator output is inverted
0	Comparator output is not inverted

**Bit 1 – HYS** Comparator Hysteresis Enable bit

Value	Description
1	Comparator hysteresis enabled
0	Comparator hysteresis disabled

**Bit 0 – SYNC** Comparator Output Synchronous Mode bit  
Output updated on the falling edge of prescaled Timer1 clock.

Value	Description
1	Comparator output to Timer1 and I/O pin is synchronous to changes on the prescaled Timer1 clock.
0	Comparator output to Timer1 and I/O pin is asynchronous

**23.15.2 CMxCON1**

**Name:** CMxCON1  
**Address:** 0x991,0x995

Comparator x Control Register 1

Bit	7	6	5	4	3	2	1	0
							INTP	INTN
Access							R/W	R/W
Reset							0	0

**Bit 1 – INTP** Comparator Interrupt on Positive-Going Edge Enable bit

Value	Description
1	The CxIF interrupt flag will be set upon a positive-going edge of the CxOUT bit
0	No interrupt flag will be set on a positive-going edge of the CxOUT bit

**Bit 0 – INTN** Comparator Interrupt on Negative-Going Edge Enable bit

Value	Description
1	The CxIF interrupt flag will be set upon a negative-going edge of the CxOUT bit
0	No interrupt flag will be set on a negative-going edge of the CxOUT bit

**23.15.3 CMxNCH**

**Name:** CMxNCH  
**Address:** 0x992,0x996

Comparator x Inverting Channel Select Register

	7		6		5		4		3		2		1		0
	NCH[2:0]														
Access												R/W	R/W	R/W	
Reset												0	0	0	

**Bits 2:0 – NCH[2:0]** Comparator Inverting Input Channel Select bits

NCH	Negative Input Sources
111	CxV <sub>N</sub> connects to AV <sub>SS</sub>
110	CxV <sub>N</sub> connects to FVR Buffer 2
101	CxV <sub>N</sub> not connected
100	CxV <sub>N</sub> not connected
011	CxV <sub>N</sub> connects to CxIN3- pin
010	CxV <sub>N</sub> connects to CxIN2- pin
001	CxV <sub>N</sub> connects to CxIN1- pin
000	CxV <sub>N</sub> connects to CxIN0- pin

**23.15.4 CMxPCH**

**Name:** CMxPCH  
**Address:** 0x993,0x997

Comparator x Non-Inverting Channel Select Register

PCH	Positive Input Source
111	CxV <sub>P</sub> connects to V <sub>SS</sub>
110	CxV <sub>P</sub> connects to FVR Buffer 2
101	CxV <sub>P</sub> connects to DAC1 output
100	CxV <sub>P</sub> not connected
011	CxV <sub>P</sub> not connected
010	CxV <sub>P</sub> not connected
001	CxV <sub>P</sub> connects to CxIN1+ pin
000	CxV <sub>P</sub> connects to CxIN0+ pin

Bit	7	6	5	4	3	2	1	0
						PCH[2:0]		
Access						R/W	R/W	R/W
Reset						0	0	0

**Bits 2:0 – PCH[2:0]** Comparator Non-Inverting Input Channel Select bits

**23.15.5 CMOUT**

**Name:** CMOUT  
**Address:** 0x98F

Comparator Output Register

Bit	7	6	5	4	3	2	1	0
							MC2OUT	MC1OUT
Access							RO	RO
Reset							0	0

**Bits 0, 1 – MCxOUT** Mirror copy of CxOUT bit

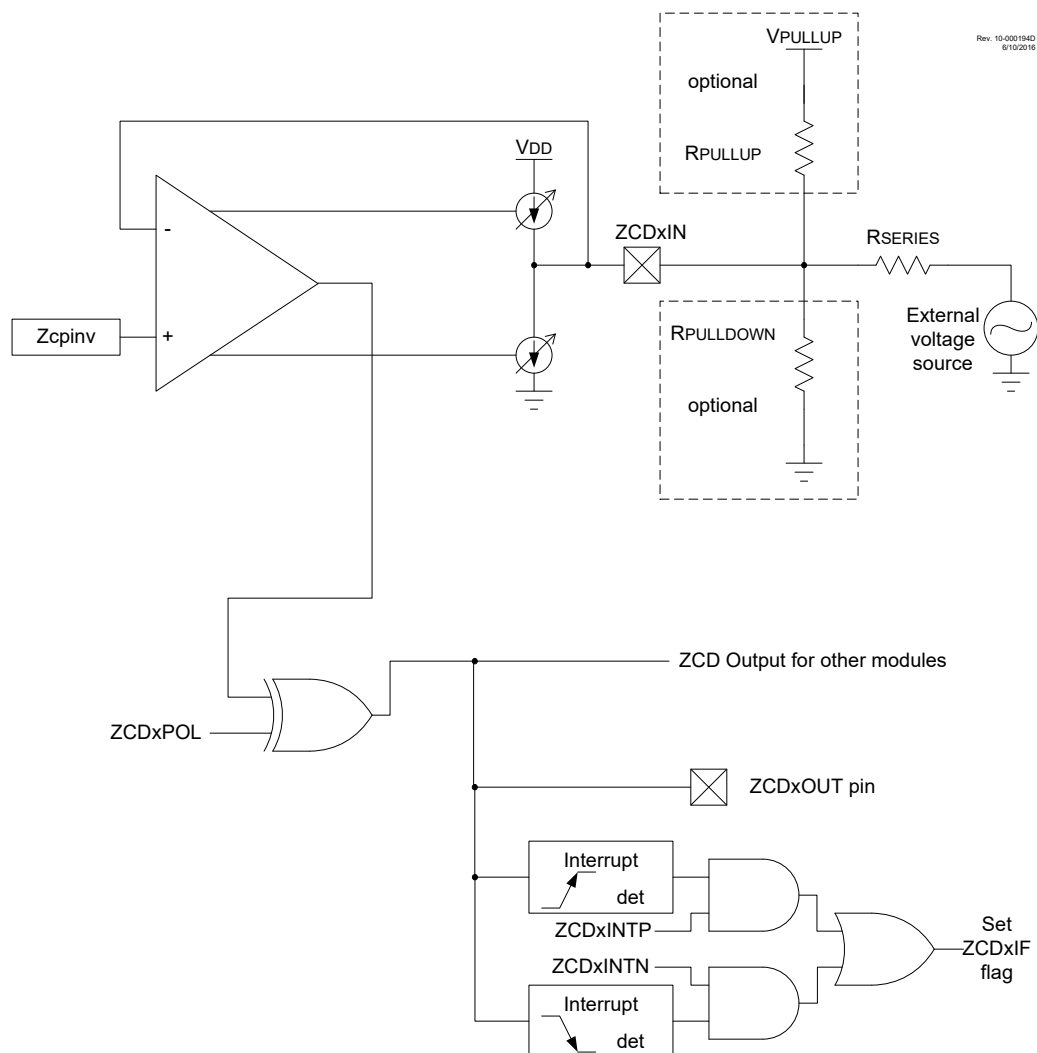


## 24. (ZCD) Zero-Cross Detection Module

The ZCD module detects when an A/C signal crosses through the ground potential. The actual zero crossing threshold is the zero crossing reference voltage,  $Z_{CPINV}$ , which is typically 0.75V above ground.

The connection to the signal to be detected is through a series current-limiting resistor. The module applies a current source or sink to the ZCD pin to maintain a constant voltage on the pin, thereby preventing the pin voltage from forward biasing the ESD protection diodes. When the applied voltage is greater than the reference voltage, the module sinks current. When the applied voltage is less than the reference voltage, the module sources current. The current source and sink action keeps the pin voltage constant over the full range of the applied voltage. The ZCD module is shown in the following simplified block diagram.

**Figure 24-1. Simplified ZCD Block Diagram**



The ZCD module is useful when monitoring an A/C waveform for, but not limited to, the following purposes:

- A/C period measurement

- Accurate long term time measurement
- Dimmer phase delayed drive
- Low EMI cycle switching

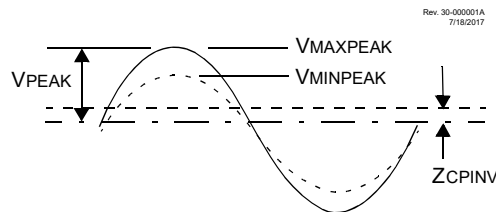
## 24.1 External Resistor Selection

The ZCD module requires a current-limiting resistor in series with the external voltage source. The impedance and rating of this resistor depends on the external source peak voltage. Select a resistor value that will drop all of the peak voltage when the current through the resistor is nominally 300  $\mu$ A. Make sure that the ZCD I/O pin internal weak pull-up is disabled so it does not interfere with the current source and sink.

### Equation 24-1. External Resistor

$$R_{SERIES} = \frac{V_{PEAK}}{3 \times 10^{-4}}$$

**Figure 24-2. External Voltage Source**



## 24.2 ZCD Logic Output

The ZCD module includes a Status bit, which can be read to determine whether the current source or sink is active. The **OUT** bit is set when the current sink is active, and cleared when the current source is active. The OUT bit is affected by the polarity bit.

The OUT signal can also be used as input to other modules. This is controlled by the registers of the corresponding module. OUT can be used as follows:

- Gate source for TMR1/3/5
- Clock source for TMR2/4/6
- Reset source for TMR2/4/6

## 24.3 ZCD Logic Polarity

The **POL** bit inverts the OUT bit relative to the current source and sink output. When the POL bit is set, a OUT high indicates that the current source is active, and a low output indicates that the current sink is active.

The POL bit affects the ZCD interrupts.

## 24.4 ZCD Interrupts

An interrupt will be generated upon a change in the ZCD logic output when the appropriate interrupt enables are set. A rising edge detector and a falling edge detector are present in the ZCD for this purpose.

The ZCDIF bit of the PIRx register will be set when either edge detector is triggered and its associated enable bit is set. The [INTP](#) enables rising edge interrupts and the [INTN](#) bit enables falling edge interrupts. Priority of the interrupt can be changed if the IPEN bit of the INTCON register is set. The ZCD interrupt can be made high or low priority by setting or clearing the ZCDIP bit of the IPRx register.

To fully enable the interrupt, the following bits must be set:

- ZCDIE bit of the PIRx register
- INTP bit for rising edge detection
- INTN bit for falling edge detection
- PEIE and GIE bits of the INTCON register

Changing the POL bit will cause an interrupt, regardless of the level of the [SEN](#) bit.

The ZCDIF bit of the PIRx register must be cleared in software as part of the interrupt service. If another edge is detected while this flag is being cleared, the flag will still be set at the end of the sequence.

### Related Links

[7.8.10 INTCON](#)

[10.7.13 PIR2](#)

## 24.5 Correction for $Z_{CPINV}$ Offset

The actual voltage at which the ZCD switches is the reference voltage at the non-inverting input of the ZCD op amp. For external voltage source waveforms other than square waves, this voltage offset from zero causes the zero-cross event to occur either too early or too late.

### 24.5.1 Correction by AC Coupling

When the external voltage source is sinusoidal, the effects of the  $Z_{CPINV}$  offset can be eliminated by isolating the external voltage source from the ZCD pin with a capacitor, in addition to the voltage reducing resistor. The capacitor will cause a phase shift resulting in the ZCD output switch in advance of the actual zero crossing event. The phase shift will be the same for both rising and falling zero crossings, which can be compensated for by either delaying the CPU response to the ZCD switch by a timer or other means, or selecting a capacitor value large enough that the phase shift is negligible.

To determine the series resistor and capacitor values for this configuration, start by computing the impedance,  $Z$ , to obtain a peak current of 300  $\mu$ A. Next, arbitrarily select a suitably large non-polar capacitor and compute its reactance,  $X_c$ , at the external voltage source frequency. Finally, compute the series resistor, capacitor peak voltage, and phase shift by the formulas shown below.

When this technique is used and the input signal is not present, the ZCD will tend to oscillate. To avoid this oscillation, connect the ZCD pin to  $V_{DD}$  or GND with a high-impedance resistor such as 200K.

#### Equation 24-2. R-C Equations

$V_{PEAK}$  = external voltage source peak voltage

f = external voltage source frequency

C = series capacitor

R = series resistor

$V_C$  = Peak capacitor voltage

$\Phi$  = Capacitor induced zero crossing phase advance in radians

$T_\Phi$  = Time ZC event occurs before actual zero crossing

$$Z = \frac{V_{PEAK}}{3 \times 10^{-4}}$$

$$X_C = \frac{1}{2\pi fC}$$

$$R = \sqrt{Z^2 - X_C^2}$$

$$V_C = X_C(3 \times 10^{-4})$$

$$\Phi = \tan^{-1}\theta\left(\frac{X_C}{R}\right)$$

$$T_\Phi = \frac{\Phi}{2\pi f}$$

**Equation 24-3. R-C Calculation Example**

$$V_{rms} = 120$$

$$V_{PEAK} = V_{rms} \times \sqrt{2} = 169.7$$

$$f = 60 \text{ Hz}$$

$$C = 0.1 \mu F$$

$$Z = \frac{V_{PEAK}}{3 \times 10^{-4}} = \frac{169.7}{3 \times 10^{-4}} = 565.7 \text{ k}\Omega$$

$$X_C = \frac{1}{2\pi fC} = \frac{1}{2\pi \times 60 \times 10^{-7}} = 26.53 \text{ k}\Omega$$

$$R = \sqrt{Z^2 - X_C^2} = 565.1 \text{ k}\Omega \text{ (computed)}$$

$$R_a = 560 \text{ k}\Omega \text{ (used)}$$

$$Z_R = \sqrt{R_a^2 + X_C^2} = 560.6 \text{ k}\Omega$$

$$I_{PEAK} = \frac{V_{PEAK}}{Z_R} = 302.7 \times 10^{-6} \text{ A}$$

$$V_C = X_C \times I_{PEAK} = 8.0 \text{ V}$$

$$\Phi = \tan^{-1}\theta\left(\frac{X_C}{R}\right) = 0.047 \text{ radians}$$

$$T_{\Phi} = \frac{\Phi}{2\pi f} = 125.6\mu s$$

### 24.5.2 Correction By Offset Current

When the waveform is varying relative to  $V_{SS}$ , then the zero cross is detected too early as the waveform falls and too late as the waveform rises. When the waveform is varying relative to  $V_{DD}$ , then the zero cross is detected too late as the waveform rises and too early as the waveform falls. The actual offset time can be determined for sinusoidal waveforms with the corresponding equations shown below.

#### Equation 24-4. ZCD Event Offset

When External Voltage source is relative to  $V_{SS}$

$$T_{offset} = \frac{\sin^{-1}\left(\frac{Z_{CPINV}}{V_{PEAK}}\right)}{2\pi f}$$

When External Voltage source is relative to  $V_{DD}$

$$T_{offset} = \frac{\sin^{-1}\left(\frac{V_{DD} - Z_{CPINV}}{V_{PEAK}}\right)}{2\pi f}$$

This offset time can be compensated for by adding a pull-up or pull-down biasing resistor to the ZCD pin. A pull-up resistor is used when the external voltage source is varying relative to  $V_{SS}$ . A pull-down resistor is used when the voltage is varying relative to  $V_{DD}$ . The resistor adds a bias to the ZCD pin so that the target external voltage source must go to zero to pull the pin voltage to the  $Z_{CPINV}$  switching voltage. The pull-up or pull-down value can be determined with the equations shown below.

#### Equation 24-5. ZCD Pull-up/Pull-down Resistor

When External Voltage source is relative to  $V_{SS}$

$$R_{pullup} = \frac{R_{SERIES}(V_{pullup} - Z_{CPINV})}{Z_{CPINV}}$$

When External Voltage source is relative to  $V_{DD}$

$$R_{pulldown} = \frac{R_{SERIES}(Z_{CPINV})}{(V_{DD} - Z_{CPINV})}$$

## 24.6 Handling $V_{PEAK}$ Variations

If the peak amplitude of the external voltage is expected to vary, the series resistor must be selected to keep the ZCD current source and sink below the design maximum range of  $\pm 600 \mu A$  and above a reasonable minimum range. A general rule of thumb is that the maximum peak voltage can be no more than six times the minimum peak voltage. To ensure that the maximum current does not exceed  $\pm 600 \mu A$  and the minimum is at least  $\pm 100 \mu A$ , compute the series resistance as shown in [Equation 24-6](#). The compensating pull-up for this series resistance can be determined with the equations shown in [Equation 24-5](#) because the pull-up value is independent from the peak voltage.

**Equation 24-6. Series R for V range**

$$R_{SERIES} = \frac{V_{MAX\_PEAK} + V_{MIN\_PEAK}}{7 \times 10^{-4}}$$

## 24.7 Operation During Sleep

The ZCD current sources and interrupts are unaffected by Sleep.

## 24.8 Effects of a Reset

The ZCD circuit can be configured to default to the active or inactive state on Power-on Reset (POR). When the  $\overline{ZCD}$  Configuration bit is cleared, the ZCD circuit will be active at POR. When the  $\overline{ZCD}$  Configuration bit is set, the **SEN** bit must be set to enable the ZCD module.

## 24.9 Disabling the ZCD Module

The ZCD module can be disabled in two ways:

1. The  $\overline{ZCD}$  Configuration bit disables the ZCD module when set. When this is the case then the ZCD module will be enabled by setting the **SEN** bit. When the  $\overline{ZCD}$  bit is clear, the ZCD is always enabled and the **SEN** bit has no effect.
2. The ZCD can also be disabled using the ZCDMD bit of the PMDx register. This is subject to the status of the  $\overline{ZCD}$  bit.

## 24.10 Register Summary: ZCD Control

Address	Name	Bit Pos.								
0x091F	ZCDCON	7:0	SEN		OUT	POL			INTP	INTN

## 24.11 Register Definitions: ZCD Control

Long bit name prefixes for the ZCD peripherals are shown in the table below. Refer to the *"Long Bit Names Section"* for more information.

**Table 24-1. ZCD Long Bit Name Prefixes**

Peripheral	Bit Name Prefix
ZCD	ZCD

### Related Links

[1.4.2.2 Long Bit Names](#)

[1.4.2.2 Long Bit Names](#)

### 24.11.1 ZCDCON

**Name:** ZCDCON  
**Address:** 0x91F

Zero-Cross Detect Control Register

Bit	7	6	5	4	3	2	1	0
	SEN		OUT	POL			INTP	INTN
Access	R/W		RO	R/W			R/W	R/W
Reset	0		x	0			0	0

**Bit 7 – SEN** Zero-Cross Detect Software Enable bit  
This bit is ignored when ZCD fuse is cleared.

Value	Condition	Description
X	ZCD Config fuse = 0	Zero-cross detect is always enabled. ZCD. This bit is ignored. source and sink current.
1	ZCD Config fuse = 1	Zero-cross detect is enabled. ZCD pin is forced to output to source and sink current.
0	ZCD Config fuse = 1	Zero-cross detect is disabled. ZCD pin operates according to PPS and TRIS controls.

**Bit 5 – OUT** Zero-Cross Detect Data Output bit

Value	Condition	Description
1	POL = 0	ZCD pin is sinking current
0	POL = 0	ZCD pin is sourcing current
1	POL = 1	ZCD pin is sourcing current
0	POL = 1	ZCD pin is sinking current

**Bit 4 – POL** Zero-Cross Detect Polarity bit

Value	Description
1	ZCD logic output is inverted
0	ZCD logic output is not inverted

**Bit 1 – INTP** Zero-Cross Detect Positive-Going Edge Interrupt Enable bit

Value	Description
1	ZCDIF bit is set on low-to-high ZCD_output transition
0	ZCDIF bit is unaffected by low-to-high ZCD_output transition

**Bit 0 – INTN** Zero-Cross Detect Negative-Going Edge Interrupt Enable bit

Value	Description
1	ZCDIF bit is set on high-to-low ZCD_output transition
0	ZCDIF bit is unaffected by high-to-low ZCD_output transition

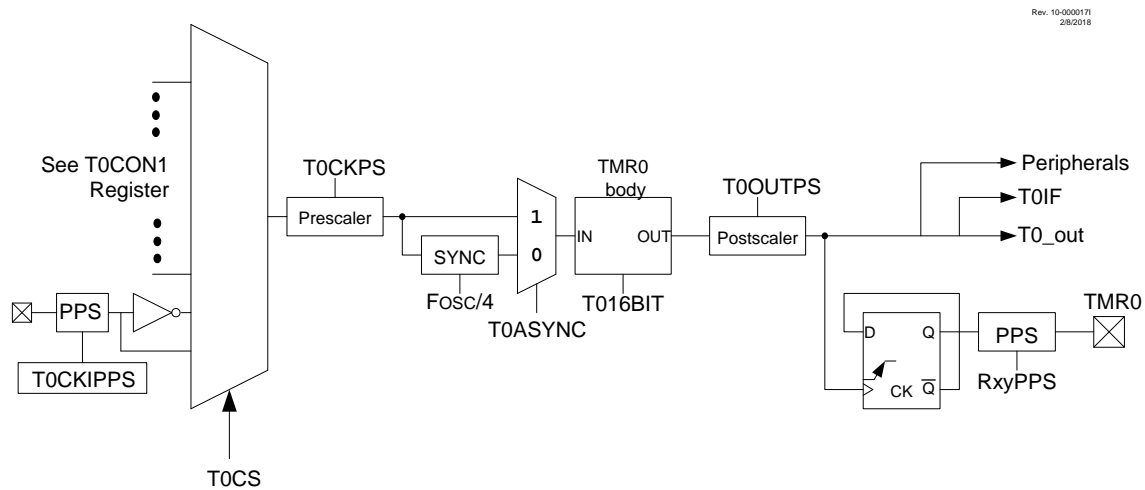


## 25. Timer0 Module

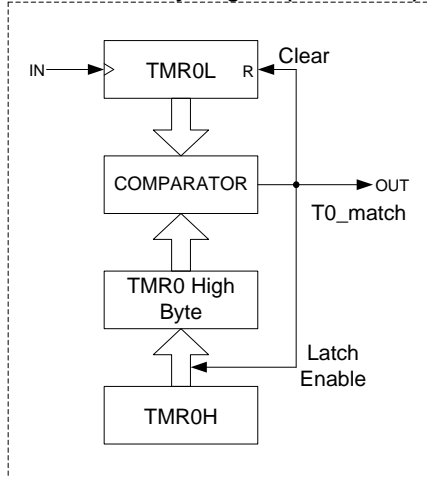
Timer0 module has the following features:

- 8-Bit B\Timer with Programmable Period
- 16-Bit Timer
- Selectable Clock Sources
- Synchronous and Asynchronous Operation
- Programmable Prescaler and Postscaler
- Interrupt on Match or Overflow
- Output on I/O Pin (via PPS) or to Other Peripherals
- Operation During Sleep

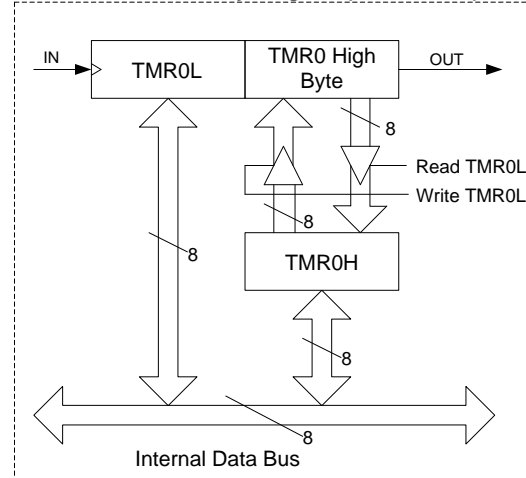
Figure 25-1. Timer0 Block Diagram



8-bit TMR0 Body Diagram (T016BIT = 0)



16-bit TMR0 Body Diagram (T016BIT = 1)



## 25.1 Timer0 Operation

Timer0 can operate as either an 8-bit or 16-bit timer. The mode is selected with the [T016BIT](#) bit.

### 25.1.1 8-bit Mode

In this mode Timer0 increments on the rising edge of the selected clock source. A prescaler on the clock input gives several prescale options (see prescaler control bits, [T0CKPS](#)).

In this mode as shown in [Figure 25-1](#), a buffered version of TMR0H is maintained. This is compared with the value of TMR0L on each cycle of the selected clock source. When the two values match, the following events occur:

- TMR0L is reset
- The contents of TMR0H are copied to the TMR0H buffer for next comparison

### 25.1.2 16-Bit Mode

In this mode Timer0 increments on the rising edge of the selected clock source. A prescaler on the clock input gives several prescale options (see prescaler control bits, [T0CKPS](#)).

In this mode TMR0H:TMR0L form the 16-bit timer value. As shown in [Figure 25-1](#), read and write of the TMR0H register are buffered. TMR0H register is updated with the contents of the high byte of Timer0 during a read of TMR0L register. Similarly, a write to the high byte of Timer0 takes place through the TMR0H buffer register. The high byte is updated with the contents of TMR0H register when a write occurs to TMR0L register. This allows all 16 bits of Timer0 to be read and written at the same time.

Timer0 rolls over to 0x0000 on incrementing past 0xFFFF. This makes the timer free running. TMR0L/H registers cannot be reloaded in this mode once started.

## 25.2 Clock Selection

Timer0 has several options for clock source selections, option to operate synchronously/asynchronously and a programmable prescaler.

### 25.2.1 Clock Source Selection

The [T0CS](#) bits are used to select the clock source for Timer0. The possible clock sources are listed in the table below.

**Table 25-1. Timer0 Clock Source Selections**

T0CS	Clock Source
111	CLC1_out
110	SOSC
101	MFINTOSC(500 kHz)
100	LFINTOSC
011	HFINTOSC
010	F <sub>Osc</sub> /4
001	Pin selected by T0CKIPPS (Inverted)
000	Pin selected by T0CKIPPS (Noninverted)

### 25.2.2 Synchronous Mode

When the [TOASYNC](#) bit is clear, Timer0 clock is synchronized to the system clock ( $F_{OSC}/4$ ). When operating in Synchronous mode, Timer0 clock frequency cannot exceed  $F_{OSC}/4$ . During Sleep mode system clock is not available and Timer0 cannot operate.

### 25.2.3 Asynchronous Mode

When the [TOASYNC](#) bit is set, Timer0 increments with each rising edge of the input source (or output of the prescaler, if used). Asynchronous mode allows Timer0 to continue operation during Sleep mode provided the selected clock source is available.

### 25.2.4 Programmable Prescaler

Timer0 has 16 programmable input prescaler options ranging from 1:1 to 1:32768. The prescaler values are selected using the [T0CKPS](#) bits.

The prescaler counter is not directly readable or writable. The prescaler counter is cleared on the following events:

- A write to the TMR0L register
- A write to either the T0CON0 or T0CON1 registers
- Any device Reset

#### Related Links

[8. Resets](#)

## 25.3 Timer0 Output and Interrupt

### 25.3.1 Programmable Postscaler

Timer0 has 16 programmable output postscaler options ranging from 1:1 to 1:16. The postscaler values are selected using the [T0OUTPS](#) bits. The postscaler divides the output of Timer0 by the selected ratio.

The postscaler counter is not directly readable or writable. The postscaler counter is cleared on the following events:

- A write to the TMR0L register
- A write to either the T0CON0 or T0CON1 registers
- Any device Reset

### 25.3.2 Timer0 Output

TMR0\_out is the output of the postscaler. TMR0\_out toggles on every match between TMR0L and TMR0H in 8-bit mode, or when TMR0H:TMR0L rolls over in 16-bit mode. If the output postscaler is used, the output is scaled by the ratio selected.

The Timer0 output can be routed to an I/O pin via the RxyPPS output selection register. The Timer0 output can be monitored through software via the [T0OUT](#) output bit.

#### Related Links

[15.2 PPS Outputs](#)

### 25.3.3 Timer0 Interrupt

The Timer0 Interrupt Flag bit (TMR0IF) is set when the TMR0\_out toggles. If the Timer0 interrupt is enabled (TMR0IE), the CPU will be interrupted when the TMR0IF bit is set.

When the postscaler bits (T0OUTPS) are set to 1:1 operation (no division), the T0IF flag bit will be set with every TMR0 match or rollover. In general, the TMR0IF flag bit will be set every T0OUTPS + 1 matches or rollovers.

#### 25.3.4 Timer0 Example

Timer0 Configuration:

- Timer0 mode = 16-bit
- Clock Source =  $F_{OSC}/4$  (250 kHz)
- Synchronous operation
- Prescaler = 1:1
- Postscaler = 1:2 (T0OUTPS = 1)

In this case the TMR0\_out toggles every two rollovers of TMR0H:TMR0L. i.e.,  $(0xFFFF) * 2 * (1/250kHz) = 524.28$  ms

#### 25.4 Operation During Sleep

When operating synchronously, Timer0 will halt when the device enters Sleep mode.

When operating asynchronously and selected clock source is active, Timer0 will continue to increment and wake the device from Sleep mode if Timer0 interrupt is enabled.

## 25.5 Register Summary - Timer0

Address	Name	Bit Pos.							
0x059C	TMR0L	7:0	TMR0L[7:0]						
0x059D	TMR0H	7:0	TMR0H[7:0]						
0x059E	T0CON0	7:0	T0EN		T0OUT	T016BIT	T0OUTPS[3:0]		
0x059F	T0CON1	7:0	T0CS[2:0]			T0ASYNC	T0CKPS[3:0]		

## 25.6 Register Definitions: Timer0 Control

### 25.6.1 T0CON0

**Name:** T0CON0

**Address:** 0x59E

Timer0 Control Register 0

Bit	7	6	5	4	3	2	1	0
	T0EN		T0OUT	T016BIT	T0OUTPS[3:0]			
Access	R/W		R	R/W	R/W	R/W	R/W	R/W
Reset	0		0	0	0	0	0	0

**Bit 7 – T0EN** TMR0 Enable bit

Value	Description
1	The module is enabled and operating
0	The module is disabled

**Bit 5 – T0OUT** TMR0 Output bit

**Bit 4 – T016BIT** TMR0 Operating as 16-Bit Timer Select bit

Value	Description
1	TMR0 is a 16-bit timer
0	TMR0 is an 8-bit timer

**Bits 3:0 – T0OUTPS[3:0]** TMR0 Output Postscaler (Divider) Select bits

Value	Description
1111	1:16 Postscaler
1110	1:15 Postscaler
1101	1:14 Postscaler
1100	1:13 Postscaler
1011	1:12 Postscaler
1010	1:11 Postscaler
1001	1:10 Postscaler
1000	1:9 Postscaler
0111	1:8 Postscaler
0110	1:7 Postscaler
0101	1:6 Postscaler
0100	1:5 Postscaler
0011	1:4 Postscaler
0010	1:3 Postscaler
0001	1:2 Postscaler
0000	1:1 Postscaler

25.6.2 T0CON1

**Name:** T0CON1  
**Address:** 0x59F

Timer0 Control Register 1

Bit	7	6	5	4	3	2	1	0
	T0CS[2:0]			T0ASYNC	T0CKPS[3:0]			
Access	R/W	R/W	R/W	R/W	R/W	R/W	R/W	R/W
Reset	0	0	0	0	0	0	0	0

**Bits 7:5 – T0CS[2:0]** Timer0 Clock Source Select bits  
Refer the clock source selection [table](#)

**Bit 4 – T0ASYNC** TMR0 Input Asynchronization Enable bit

Value	Description
1	The input to the TMR0 counter is not synchronized to system clocks
0	The input to the TMR0 counter is synchronized to Fosc/4

**Bits 3:0 – T0CKPS[3:0]** Prescaler Rate Select bit

Value	Description
1111	1:32768
1110	1:16384
1101	1:8192
1100	1:4096
1011	1:2048
1010	1:1024
1001	1:512
1000	1:256
0111	1:128
0110	1:64
0101	1:32
0100	1:16
0011	1:8
0010	1:4
0001	1:2
0000	1:1

25.6.3 TMR0H

**Name:** TMR0H

**Address:** 0x59D

Timer0 Period/Count High Register

Bit	7	6	5	4	3	2	1	0
	TMR0H[7:0]							
Access	R/W	R/W	R/W	R/W	R/W	R/W	R/W	R/W
Reset	0	0	0	0	0	0	0	0

**Bits 7:0 – TMR0H[7:0]** TMR0 Most Significant Counter bits

Value	Condition	Description
0 to 255	T016BIT = 0	8-bit Timer0 Period Value. TMR0L continues counting from 0 when this value is reached.
0 to 255	T016BIT = 1	16-bit Timer0 Most Significant Byte



25.6.4 TMR0L

**Name:** TMR0L  
**Address:** 0x59C

Timer0 Period/Count Low Register

Bit	7	6	5	4	3	2	1	0
	TMR0L[7:0]							
Access	R/W	R/W	R/W	R/W	R/W	R/W	R/W	R/W
Reset	0	0	0	0	0	0	0	0

**Bits 7:0 – TMR0L[7:0]** TMR0 Least Significant Counter bits

Value	Condition	Description
0 to 255	T016BIT = 0	8-bit Timer0 Counter bits
0 to 255	T016BIT = 1	16-bit Timer0 Least Significant Byte

## 26. Timer1 Module with Gate Control

Timer1 module is a 16-bit timer/counter with the following features:

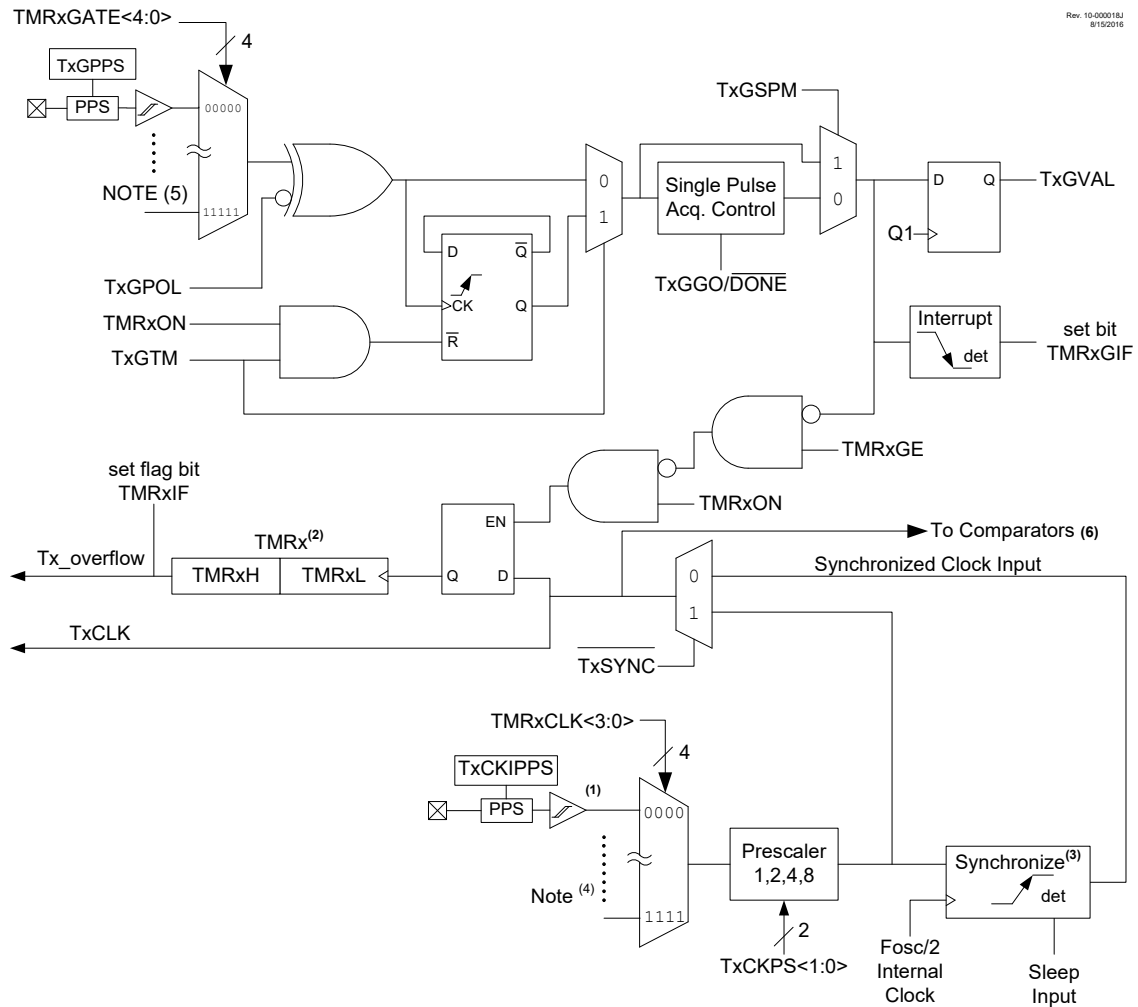
- 16-Bit Timer/Counter Register Pair (TMRxH:TMRxL)
- Programmable Internal or External Clock Source
- 2-Bit Prescaler
- Optionally Synchronized Comparator Out
- Multiple Timer1 Gate (count enable) Sources
- Interrupt-on-Overflow
- Wake-Up on Overflow (external clock, Asynchronous mode only)
- 16-Bit Read/Write Operation
- Time Base for the Capture/Compare Function with the CCP modules
- Special Event Trigger (with CCP)
- Selectable Gate Source Polarity
- Gate Toggle mode
- Gate Single-Pulse mode
- Gate Value Status
- Gate Event Interrupt



**Important:** References to module Timer1 apply to all the odd numbered timers on this device.

---

Figure 26-1. Timer1 Block Diagram



**Note:**

1. This signal comes from the pin selected by TxCKIPPS.
2. TMRx register increments on rising edge.
3. Synchronize does not operate while in Sleep.
4. See [TMRxCLK](#) for clock source selections.
5. See [TMRxGATE](#) for gate source selection.
6. Synchronized comparator output should not be used in conjunction with synchronized input clock.

## 26.1 Timer1 Operation

The Timer1 module is a 16-bit incrementing counter that is accessed through the TMRxH:TMRxL register pair. Writes to TMRxH or TMRxL directly update the counter.

When used with an internal clock source, the module is a timer and increments on every instruction cycle. When used with an external clock source, the module can be used as either a timer or counter and increments on every selected edge of the external source.

Timer1 is enabled by configuring the **ON** and **GE** bits in the TxCON and TxGCON registers, respectively. The table below displays the Timer1 enable selections.

**Table 26-1. Timer1 Enable Selections**

ON	GE	Timer1 Operation
1	1	Count Enabled
1	0	Always On
0	1	Off
0	0	Off

## 26.2 Clock Source Selection

The **CS** bits select the clock source for Timer1. These bits allow the selection of several possible synchronous and asynchronous clock sources. The table below lists the clock source selections.

**Table 26-2. Timer Clock Sources**

CS	Clock Source		
	Timer1	Timer3	Timer5
11111-10001	Reserved	Reserved	Reserved
10000	CLC4_out	CLC4_out	CLC4_out
01111	CLC3_out	CLC3_out	CLC3_out
01110	CLC2_out	CLC2_out	CLC2_out
01101	CLC1_out	CLC1_out	CLC1_out
01100	Timer5 overflow output	Timer5 overflow output	Reserved
01011	Timer3 overflow output	Reserved	Timer3 overflow output
01010	Reserved	Timer1 overflow output	Timer1 overflow output
01001	Timer0 overflow output	Timer0 overflow output	Timer0 overflow output
01000	CLKR output	CLKR output	CLKR output
00111	SOSC	SOSC	SOSC
00110	MFINTOSC (32 kHz)	MFINTOSC (32 kHz)	MFINTOSC (32 kHz)
00101	MFINTOSC (500 kHz)	MFINTOSC (500 kHz)	MFINTOSC (500 kHz)
00100	LFINTOSC	LFINTOSC	LFINTOSC
00011	HFINTOSC	HFINTOSC	HFINTOSC
00010	F <sub>Osc</sub>	F <sub>Osc</sub>	F <sub>Osc</sub>
00001	F <sub>Osc</sub> /4	F <sub>Osc</sub> /4	F <sub>Osc</sub> /4
00000	T1CKIPPS	T3CKIPPS	T5CKIPPS

### 26.2.1 Internal Clock Source

When the internal clock source is selected the TMRxH:TMRxL register pair will increment on multiples of F<sub>Osc</sub> as determined by the Timer1 prescaler.

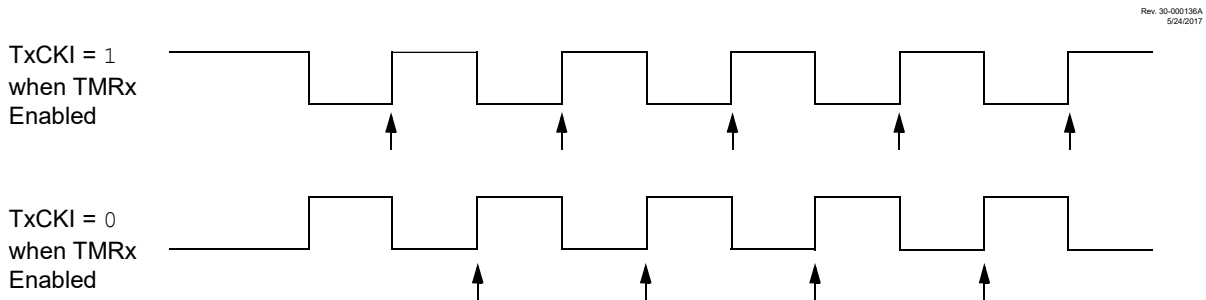
When the  $F_{OSC}$  internal clock source is selected, the Timer1 register value will increment by four counts every instruction clock cycle. Due to this condition, a 2 LSB error in resolution will occur when reading the Timer1 value. To utilize the full resolution of Timer1, an asynchronous input signal must be used to gate the Timer1 clock input.



**Important:** In Counter mode, a falling edge must be registered by the counter prior to the first incrementing rising edge after any one or more of the following conditions:

- Timer1 enabled after POR
- Write to TMRxH or TMRxL
- Timer1 is disabled
- Timer1 is disabled ( $TMRxON = 0$ ) when TxCKI is high then Timer1 is enabled ( $TMRxON = 1$ ) when TxCKI is low. Refer to the figure below.

**Figure 26-2. Timer1 Incrementing Edge**



**Note:**

1. Arrows indicate counter increments.
2. In Counter mode, a falling edge must be registered by the counter prior to the first incrementing rising edge of the clock.

**26.2.2 External Clock Source**

When the external clock source is selected, the Timer1 module may work as a timer or a counter.

When enabled to count, Timer1 is incremented on the rising edge of the external clock input of the TxCKIPPS pin. This external clock source can be synchronized to the system clock or it can run asynchronously.

**26.3 Timer1 Prescaler**

Timer1 has four prescaler options allowing 1, 2, 4 or 8 divisions of the clock input. The CKPS bits control the prescale counter. The prescale counter is not directly readable or writable; however, the prescaler counter is cleared upon a write to TMRxH or TMRxL.

**26.4 Secondary Oscillator**

A secondary low-power 32.768 kHz oscillator circuit is built-in between pins SOSCI (input) and SOSCO (amplifier output). This internal circuit is to be used in conjunction with an external 32.768 kHz crystal. The secondary oscillator is not dedicated only to Timer1; it can also be used by other modules.

The oscillator circuit is enabled by setting the SOSREN bit of the OSCEN register. This can be used as one of the Timer1 clock sources selected with the CS bits. The oscillator will continue to run during Sleep.



**Important:** The oscillator requires a start-up and stabilization time before use. Thus, the SOSREN bit of the OSCEN register should be set and a suitable delay observed prior to enabling Timer1. A software check can be performed to confirm if the secondary oscillator is enabled and ready to use. This is done by polling the SOR bit of the OSCSTAT.

#### Related Links

[9.2.1.5 Secondary Oscillator](#)

## 26.5 Timer1 Operation in Asynchronous Counter Mode

When the SYNC control bit is set, the external clock input is not synchronized. The timer increments asynchronously to the internal phase clocks. If external clock source is selected then the timer will continue to run during Sleep and can generate an interrupt on overflow, which will wake-up the processor. However, special precautions in software are needed to read/write the timer (see [26.5.1 Reading and Writing Timer1 in Asynchronous Counter Mode](#)).



**Important:** When switching from synchronous to asynchronous operation, it is possible to skip an increment. When switching from asynchronous to synchronous operation, it is possible to produce an additional increment.

### 26.5.1 Reading and Writing Timer1 in Asynchronous Counter Mode

Reading TMRxH or TMRxL while the timer is running from an external asynchronous clock will ensure a valid read (taken care of in hardware). However, the user should keep in mind that reading the 16-bit timer in two 8-bit values itself, poses certain problems, since the timer may overflow between the reads. For writes, it is recommended that the user simply stop the timer and write the desired values. A write contention may occur by writing to the timer registers, while the register is incrementing. This may produce an unpredictable value in the TMRxH:TMRxL register pair.

## 26.6 Timer1 16-Bit Read/Write Mode

Timer1 can be configured to read and write all 16 bits of data, to and from, the 8-bit TMRxL and TMRxH registers, simultaneously. The 16-bit read and write operations are enabled by setting the RD16 bit.

To accomplish this function, the TMRxH register value is mapped to a buffer register called the TMRxH buffer register. While in 16-Bit mode, the TMRxH register is not directly readable or writable and all read and write operations take place through the use of this TMRxH buffer register.

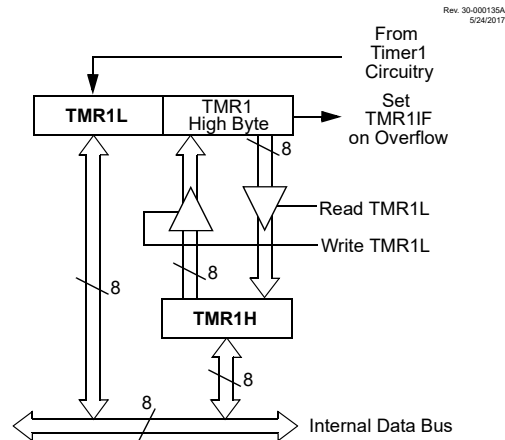
When a read from the TMRxL register is requested, the value of the TMRxH register is simultaneously loaded into the TMRxH buffer register. When a read from the TMRxH register is requested, the value is provided from the TMRxH buffer register instead. This provides the user with the ability to accurately read all 16 bits of the Timer1 value from a single instance in time. Refer the figure below for more details.

In contrast, when not in 16-Bit mode, the user must read each register separately and determine if the values have become invalid due to a rollover that may have occurred between the read operations.

When a write request of the TMRxL register is requested, the TMRxH buffer register is simultaneously updated with the contents of the TMRxH register. The value of TMRxH must be preloaded into the TMRxH buffer register prior to the write request for the TMRxL register. This provides the user with the ability to write all 16 bits to the TMRxL:TMRxH register pair at the same time.

Any requests to write to the TMRxH directly does not clear the Timer1 prescaler value. The prescaler value is only cleared through write requests to the TMRxL register.

**Figure 26-3. Timer1 16-Bit Read/Write Mode Block Diagram**



## 26.7 Timer1 Gate

Timer1 can be configured to count freely or the count can be enabled and disabled using Timer1 gate circuitry. This is also referred to as Timer1 gate enable.

Timer1 gate can also be driven by multiple selectable sources.

### 26.7.1 Timer1 Gate Enable

The Timer1 Gate Enable mode is enabled by setting the **GE** bit. The polarity of the Timer1 Gate Enable mode is configured using the **GPOL** bit.

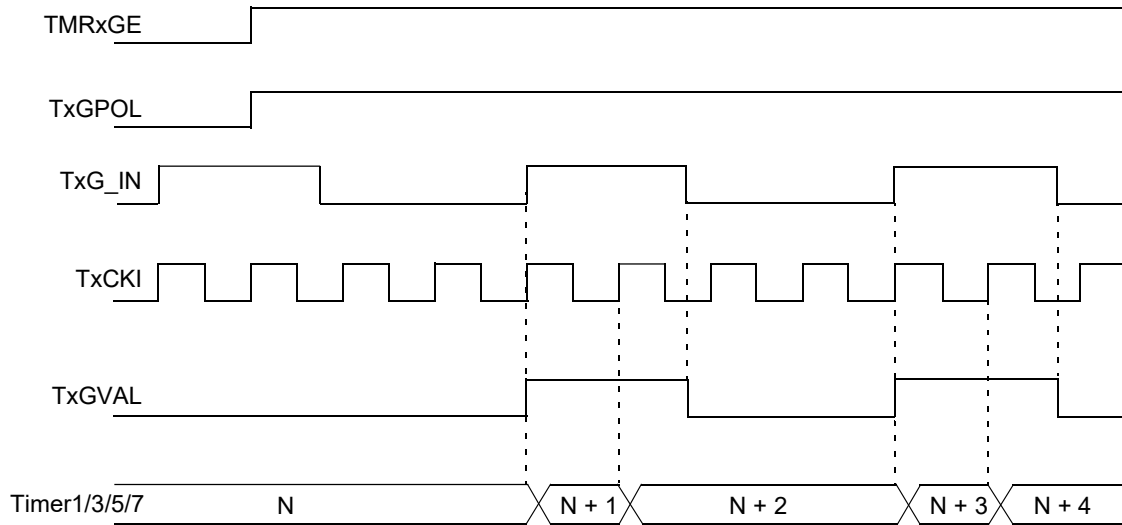
When Timer1 Gate Enable mode is enabled, Timer1 will increment on the rising edge of the Timer1 clock source. When Timer1 Gate signal is inactive, the timer will not increment and hold the current count. Enable mode is disabled, no incrementing will occur and Timer1 will hold the current count. See figure below for timing details.

**Table 26-3. Timer1 Gate Enable Selections**

TMRxCLK	GPOL	TxG	Timer1 Operation
↑	1	1	Counts
↑	1	0	Holds Count
↑	0	1	Holds Count
↑	0	0	Counts

**Figure 26-4. Timer1 Gate Enable Mode**

Rev. 30-000137A  
5/24/2017



### 26.7.2 Timer1 Gate Source Selection

The gate source for Timer1 is selected using the **GSS** bits. The polarity selection for the gate source is controlled by the **GPOL** bit. The table below lists the gate source selections.

**Table 26-4. Timer Gate Sources**

GSS	Gate Source		
	Timer1	Timer3	Timer5
11111-11001	Reserved	Reserved	Reserved
11000	SMT2_overflow	SMT2_overflow	SMT2_overflow
10111	CCP5_out	CCP5_out	CCP5_out
10110	CLC4_out	CLC4_out	CLC4_out
10101	CLC3_out	CLC3_out	CLC3_out
10100	CLC2_out	CLC2_out	CLC2_out
10011	CLC1_out	CLC1_out	CLC1_out
10010	ZCD1_output	ZCD1_output	ZCD1_output
10001	C2OUT_sync	C2OUT_sync	C2OUT_sync
10000	C1OUT_sync	C1OUT_sync	C1OUT_sync
01111	NCO1_out	NCO1_out	NCO1_out
01110	PWM7_out	PWM7_out	PWM7_out
01101	PWM6_out	PWM6_out	PWM6_out



GSS	Gate Source		
	Timer1	Timer3	Timer5
01100	CCP4_out	CCP4_out	CCP4_out
01011	CCP3_out	CCP3_out	CCP3_out
01010	CCP2_out	CCP2_out	CCP2_out
01001	CCP1_out	CCP1_out	CCP1_out
01000	SMT1_overflow	SMT1_overflow	SMT1_overflow
00111	TMR6_postscaled output	TMR6_postscaled output	TMR6_postscaled output
00110	Timer5 overflow output	Timer5 overflow output	Reserved
00101	TMR4_postscaled output	TMR4_postscaled output	TMR4_postscaled output
00100	Timer3 overflow output	Reserved	Timer3 overflow output
00011	TMR2_postscaled output	TMR2_postscaled output	TMR2_postscaled output
00010	Reserved	Timer1 overflow output	Timer1 overflow output
00001	Timer0 overflow output	Timer0 overflow output	Timer0 overflow output
00000	T1GPPS	T3GPPS	T5GPPS

Any of the above mentioned signals can be used to trigger the gate. The output of the CMPx can be synchronized to the Timer1 clock or left asynchronous. For more information refer to the Comparator Output Synchronization section.

**Related Links**

[23.4.1 Comparator Output Synchronization](#)

**26.7.3 Timer1 Gate Toggle Mode**

When Timer1 Gate Toggle mode is enabled, it is possible to measure the full-cycle length of a Timer1 gate signal, as opposed to the duration of a single level pulse.

The Timer1 gate source is routed through a flip-flop that changes state on every incrementing edge of the signal. See figure below for timing details.

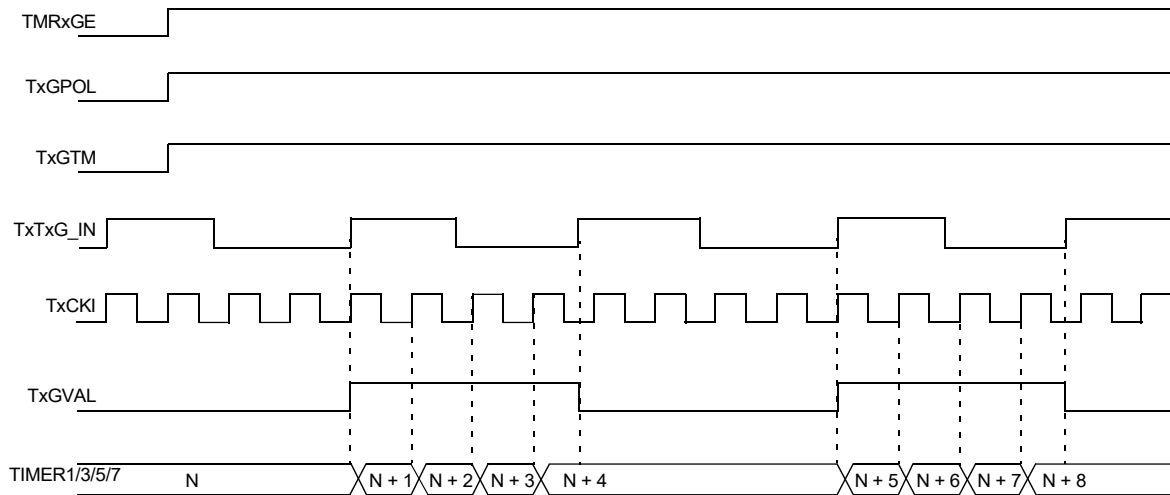
Timer1 Gate Toggle mode is enabled by setting the **GTM** bit. When the GTM bit is cleared, the flip-flop is cleared and held clear. This is necessary in order to control which edge is measured.



**Important:** Enabling Toggle mode at the same time as changing the gate polarity may result in indeterminate operation.

Figure 26-5. TIMER1 GATE TOGGLE MODE

Rev. 30-000138A  
 5/29/2017



#### 26.7.4 Timer1 Gate Single-Pulse Mode

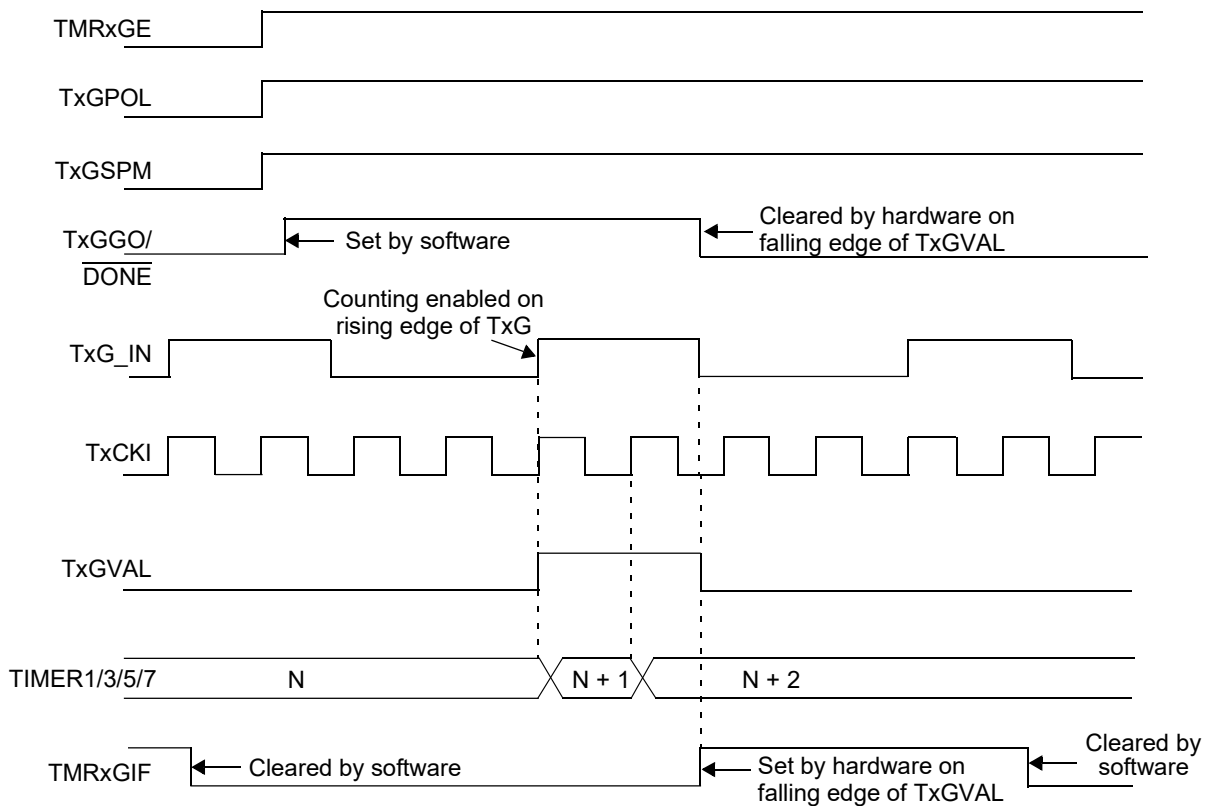
When Timer1 Gate Single-Pulse mode is enabled, it is possible to capture a single-pulse gate event. Timer1 Gate Single-Pulse mode is first enabled by setting the **GSPM** bit. Next, the **GGO/DONE** must be set. The Timer1 will be fully enabled on the next incrementing edge. On the next trailing edge of the pulse, the **GGO/DONE** bit will automatically be cleared. No other gate events will be allowed to increment Timer1 until the **GGO/DONE** bit is once again set in software.

Clearing the **GSPM** bit will also clear the **GGO/DONE** bit. See figure below for timing details.

Enabling the Toggle mode and the Single-Pulse mode simultaneously will permit both sections to work together. This allows the cycle times on the Timer1 gate source to be measured. See figure below for timing details.

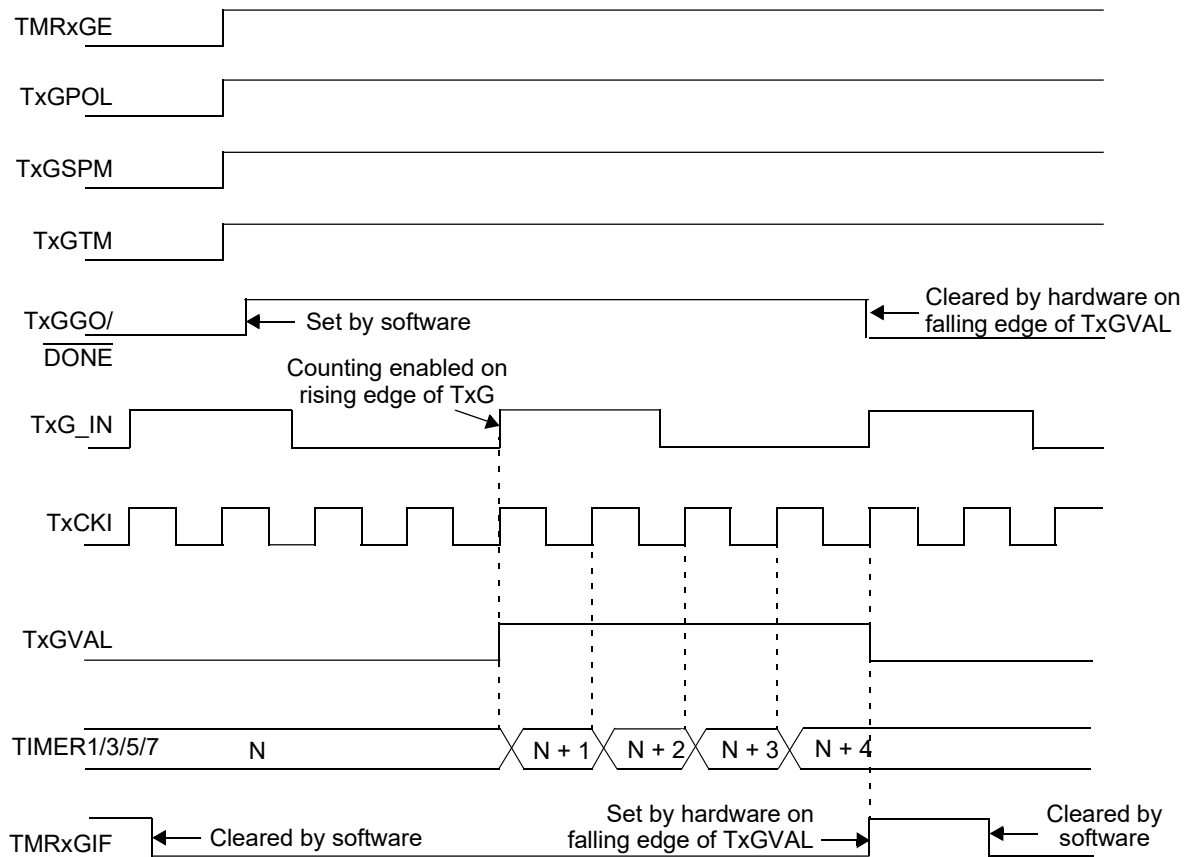
Figure 26-6. TIMER1 GATE SINGLE-PULSE MODE

Rev. 30-000139A  
 5/26/2017



**Figure 26-7. TIMER1 GATE SINGLE-PULSE AND TOGGLE COMBINED MODE**

Rev. 30-000140A  
5/25/2017



### 26.7.5 Timer1 Gate Value Status

When Timer1 Gate Value Status is utilized, it is possible to read the most current level of the gate control value. The value is stored in the GVAL bit in the TxGCON register. The GVAL bit is valid even when the Timer1 gate is not enabled (GE bit is cleared).

### 26.7.6 Timer1 Gate Event Interrupt

When Timer1 gate event interrupt is enabled, it is possible to generate an interrupt upon the completion of a gate event. When the falling edge of GVAL occurs, the TMRxGIF flag bit in the PIR5 register will be set. If the TMRxGIE bit in the PIE5 register is set, then an interrupt will be recognized.

The TMRxGIF flag bit operates even when the Timer1 gate is not enabled (GE bit is cleared).

For more information on selecting high or low priority status for the Timer1 gate event interrupt see the Interrupts chapter.

## 26.8 Timer1 Interrupt

The Timer1 register pair (TMRxH:TMRxL) increments to FFFFh and rolls over to 0000h. When Timer1 rolls over, the Timer1 interrupt flag bit of the PIRx register is set. To enable the interrupt-on-rollover, the following bits must be set:

- TMRxON bit of the TxCON register
- TMRxIE bits of the PIEx register
- PEIE/GIEL bit of the INTCON register
- GIE/GIEH bit of the INTCON register

The interrupt is cleared by clearing the TMRxIF bit in the Interrupt Service Routine.

For more information on selecting high or low priority status for the Timer1 overflow interrupt, see the Interrupts chapter.



**Important:** The TMRxH:TMRxL register pair and the TMRxIF bit should be cleared before enabling interrupts.

---

## 26.9 Timer1 Operation During Sleep

Timer1 can only operate during Sleep when set up in Asynchronous Counter mode. In this mode, an external crystal or clock source can be used to increment the counter. To set up the timer to wake the device:

- TMRxON bit of the TxCON register must be set
- TMRxIE bit of the PIEx register must be set
- PEIE/GIEL bit of the INTCON register must be set
- $\overline{\text{TxSYNC}}$  bit of the TxCON register must be set
- Configure the TMRxCLK register for using secondary oscillator as the clock source
- Enable the SOSSEN bit of the OSCEN register

The device will wake-up on an overflow and execute the next instruction. If the GIE/GIEH bit of the INTCON register is set, the device will call the Interrupt Service Routine.

The secondary oscillator will continue to operate in Sleep regardless of the  $\overline{\text{TxSYNC}}$  bit setting.

## 26.10 CCP Capture/Compare Time Base

The CCP modules use the TMRxH:TMRxL register pair as the time base when operating in Capture or Compare mode.

In Capture mode, the value in the TMRxH:TMRxL register pair is copied into the CCPRxH:CCPRxL register pair on a configured event.

In Compare mode, an event is triggered when the value in the CCPRxH:CCPRxL register pair matches the value in the TMRxH:TMRxL register pair. This event can be a Special Event Trigger.

For more information, see Capture/Compare/PWM Module(CCP) chapter.

### Related Links

[29. Capture/Compare/PWM Module](#)

### **26.11 CCP Special Event Trigger**

When any of the CCPs are configured to trigger a special event, the trigger will clear the TMRxH:TMRxL register pair. This special event does not cause a Timer1 interrupt. The CCP module may still be configured to generate a CCP interrupt.

In this mode of operation, the CCPRxH:CCPRxL register pair becomes the period register for Timer1.

Timer1 should be synchronized and  $F_{OSC}/4$  should be selected as the clock source in order to utilize the special event trigger. Asynchronous operation of Timer1 can cause a special event trigger to be missed.

In the event that a write to TMRxH or TMRxL coincides with a special event trigger from the CCP, the write will take precedence.

### **26.12 Peripheral Module Disable**

When a peripheral is not used or inactive, the module can be disabled by setting the Module Disable bit in the PMD registers. This will reduce power consumption to an absolute minimum. Setting the PMD bits holds the module in Reset and disconnects the module's clock source. The Module Disable bits for Timer1 (TMR1MD) are in the PMD1 register. See Peripheral Module Disable (PMD) chapter for more information.

#### **Related Links**

[16.4 Register Summary - PMD](#)

### 26.13 Register Summary - Timer1

Address	Name	Bit Pos.									
0x020C	TMR1	7:0	TMRxL[7:0]								
		15:8	TMRxH[7:0]								
0x020E	T1CON	7:0			CKPS[1:0]		SYNC	RD16	ON		
0x020F	T1GCON	7:0	GE	GPOL	GTM	GSPM	GGO/DONE	GVAL			
0x0210	TMR1GATE	7:0					GSS[4:0]				
0x0211	TMR1CLK	7:0					CS[4:0]				
0x0212	TMR3	7:0	TMRxL[7:0]								
		15:8	TMRxH[7:0]								
0x0214	T3CON	7:0			CKPS[1:0]		SYNC	RD16	ON		
0x0215	T3GCON	7:0	GE	GPOL	GTM	GSPM	GGO/DONE	GVAL			
0x0216	TMR3GATE	7:0					GSS[4:0]				
0x0217	TMR3CLK	7:0					CS[4:0]				
0x0218	TMR5	7:0	TMRxL[7:0]								
		15:8	TMRxH[7:0]								
0x021A	T5CON	7:0			CKPS[1:0]		SYNC	RD16	ON		
0x021B	T5GCON	7:0	GE	GPOL	GTM	GSPM	GGO/DONE	GVAL			
0x021C	TMR5GATE	7:0					GSS[4:0]				
0x021D	TMR5CLK	7:0					CS[4:0]				

### 26.14 Register Definitions: Timer1

Long bit name prefixes for the odd numbered timers is shown in the following table. Refer to the "Long Bit Names" section for more information.

**Table 26-5. Timer1 prefixes**

Peripheral	Bit Name Prefix
Timer1	T1
Timer3	T3
Timer5	T5

#### Related Links

[1.4.2.2 Long Bit Names](#)

**26.14.1 TxCON**

**Name:** TxCON  
**Address:** 0x20E,0x214,0x21A

Timer Control Register

Bit	7	6	5	4	3	2	1	0
			CKPS[1:0]			SYNC	RD16	ON
Access			R/W	R/W		R/W	R/W	R/W
Reset			0	0		0	0	0

**Bits 5:4 – CKPS[1:0]** Timer Input Clock Prescale Select bits

Reset States: POR/BOR = 00  
 All Other Resets = uu

Value	Description
11	1:8 Prescale value
10	1:4 Prescale value
01	1:2 Prescale value
00	1:1 Prescale value

**Bit 2 – SYNC** Timer External Clock Input Synchronization Control bit

Reset States: POR/BOR = 0  
 All Other Resets = u

Value	Condition	Description
X	CS = F <sub>OSC</sub> /4 or F <sub>OSC</sub>	This bit is ignored. Timer uses the incoming clock as is.
1	Else	Do not synchronize external clock input
0	Else	Synchronize external clock input with system clock

**Bit 1 – RD16** 16-Bit Read/Write Mode Enable bit

Reset States: POR/BOR = 0  
 All Other Resets = u

Value	Description
1	Enables register read/write of Timer in one 16-bit operation
0	Enables register read/write of Timer in two 8-bit operations

**Bit 0 – ON** Timer On bit

Reset States: POR/BOR = 0  
 All Other Resets = u

Value	Description
1	Enables Timer
0	Disables Timer



**26.14.2 TxGCON**

**Name:** TxGCON  
**Address:** 0x20F,0x215,0x21B

Timer Gate Control Register

Bit	7	6	5	4	3	2	1	0
	GE	GPOL	GTM	GSPM	GGO/DONE	GVAL		
Access	R/W	R/W	R/W	R/W	R/W	RO		
Reset	0	0	0	0	0	x		

**Bit 7 – GE** Timer Gate Enable bit  
Reset States: POR/BOR = 0  
All Other Resets = u

Value	Condition	Description
1	ON = 1	Timer counting is controlled by the Timer gate function
0	ON = 1	Timer is always counting
X	ON = 0	This bit is ignored

**Bit 6 – GPOL** Timer Gate Polarity bit  
Reset States: POR/BOR = 0  
All Other Resets = u

Value	Description
1	Timer gate is active-high (Timer counts when gate is high)
0	Timer gate is active-low (Timer counts when gate is low)

**Bit 5 – GTM** Timer Gate Toggle Mode bit  
Timer Gate Flip-Flop Toggles on every rising edge  
Reset States: POR/BOR = 0  
All Other Resets = u

Value	Description
1	Timer Gate Toggle mode is enabled
0	Timer Gate Toggle mode is disabled and Toggle flip-flop is cleared

**Bit 4 – GSPM** Timer Gate Single Pulse Mode bit  
Reset States: POR/BOR = 0  
All Other Resets = u

Value	Description
1	Timer Gate Single Pulse mode is enabled and is controlling Timer gate)
0	Timer Gate Single Pulse mode is disabled

**Bit 3 – GGO/DONE** Timer Gate Single Pulse Acquisition Status bit  
This bit is automatically cleared when TxGSPM is cleared.  
Reset States: POR/BOR = 0  
All Other Resets = u

# PIC16(L)F18455/56

## Timer1 Module with Gate Control

Value	Description
1	Timer Gate Single Pulse Acquisition is ready, waiting for an edge
0	Timer Gate Single Pulse Acquisition has completed or has not been started.

**Bit 2 – GVAL** Timer Gate Current State bit

Indicates the current state of the Timer gate that could be provided to TMRxH:TMRxL

Unaffected by Timer Gate Enable (TMRxGE)

**26.14.3 TMRxCLK**

**Name:** TMRxCLK  
**Address:** 0x211,0x217,0x21D

Timer Clock Source Selection Register

Bit	7	6	5	4	3	2	1	0
				CS[4:0]				
Access				R/W	R/W	R/W	R/W	R/W
Reset				0	0	0	0	0

**Bits 4:0 – CS[4:0]** Timer Clock Source Selection bits  
Refer to the clock source selection [table](#).

Reset States: POR/BOR = 00000  
All Other Resets = uuuuu

**26.14.4 TMRxGATE**

**Name:** TMRxGATE  
**Address:** 0x210,0x216,0x21C

Timer Gate Source Selection Register

Bit	7	6	5	4	3	2	1	0
				GSS[4:0]				
Access				R/W	R/W	R/W	R/W	R/W
Reset				0	0	0	0	0

**Bits 4:0 – GSS[4:0]** Timer Gate Source Selection bits  
Refer to the [gate source selection table](#).

Reset States: POR/BOR = 00000  
All Other Resets = uuuuu

**26.14.5 TMRx**

**Name:** TMRx  
**Address:** 0x20C,0x212,0x218

Timer Low Byte Register

Bit	15	14	13	12	11	10	9	8
	TMRxH[7:0]							
Access	R/W	R/W	R/W	R/W	R/W	R/W	R/W	R/W
Reset	0	0	0	0	0	0	0	0
Bit	7	6	5	4	3	2	1	0
	TMRxL[7:0]							
Access	R/W	R/W	R/W	R/W	R/W	R/W	R/W	R/W
Reset	0	0	0	0	0	0	0	0

**Bits 15:8 – TMRxH[7:0]** Timer Most Significant Byte  
 Reset States: POR/BOR = 00000000  
 All Other Resets = uuuuuuuu

**Bits 7:0 – TMRxL[7:0]** Timer Least Significant Byte  
 Reset States: POR/BOR = 00000000  
 All Other Resets = uuuuuuuu

## 27. Timer2 Module

The Timer2 module is a 8-bit timer that incorporates the following features:

- 8-Bit Timer and Period Registers
- Readable and Writable
- Software Programmable Prescaler (1:1 to 1:128)
- Software Programmable Postscaler (1:1 to 1:16)
- Interrupt on T2TMR Match with T2PR
- One-Shot Operation
- Full Asynchronous Operation
- Includes Hardware Limit Timer (HLT)
- Alternate Clock Sources
- External Timer Reset Signal Sources
- Configurable Timer Reset Operation

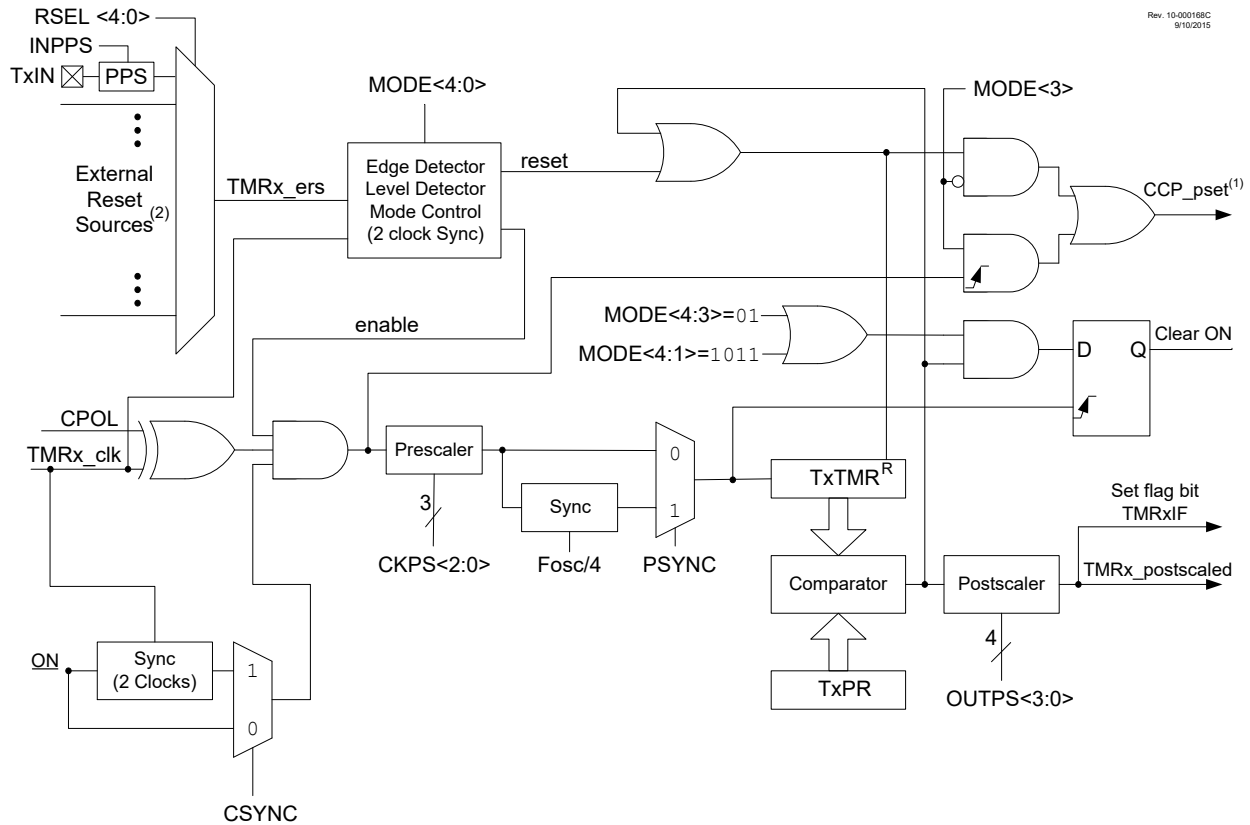
See [Figure 27-1](#) for a block diagram of Timer2. See table below for the clock source selections.



**Important:** References to module Timer2 apply to all the even numbered timers on this device. (Timer2, Timer4, etc.)

---

Figure 27-1. Timer2 with Hardware Limit Timer (HLT) Block Diagram



**Note:**

1. Signal to the CCP to trigger the PWM pulse.
2. See [TxRST](#) for external Reset sources.

Table 27-1. Clock Source Selection

CS<3:0>	Clock Source		
	Timer2	Timer4	Timer6
1111	Reserved	Reserved	Reserved
1110	CLC4_out	CLC4_out	CLC4_out
1101	CLC3_out	CLC3_out	CLC3_out
1100	CLC2_out	CLC2_out	CLC2_out
1011	CLC1_out	CLC1_out	CLC1_out
1010	ZCD1_output	ZCD1_output	ZCD1_output
1001	NCO1_out	NCO1_out	NCO1_out
1000	CLKR	CLKR	CLKR
0111	SOSC	SOSC	SOSC

CS<3:0>	Clock Source		
	Timer2	Timer4	Timer6
0110	MFINTOSC(31.25 kHz)	MFINTOSC(31.25 kHz)	MFINTOSC(31.25 kHz)
0101	MFINTOSC(500 kHz)	MFINTOSC(500 kHz)	MFINTOSC(500 kHz)
0100	LFINTOSC	LFINTOSC	LFINTOSC
0011	HFINTOSC(32 MHz)	HFINTOSC(32 MHz)	HFINTOSC(32 MHz)
0010	F <sub>osc</sub>	F <sub>osc</sub>	F <sub>osc</sub>
0001	F <sub>osc</sub> /4	F <sub>osc</sub> /4	F <sub>osc</sub> /4
0000	T2CKIPPS	T4CKIPPS	T6CKIPPS

### 27.1 Timer2 Operation

Timer2 operates in three major modes:

- Free Running Period
- One-shot
- Monostable

Within each mode there are several options for starting, stopping, and reset. [Table 27-3](#) lists the options.

In all modes, the T2TMR count register is incremented on the rising edge of the clock signal from the programmable prescaler. When T2TMR equals T2PR, a high level is output to the postscaler counter. T2TMR is cleared on the next clock input.

An external signal from hardware can also be configured to gate the timer operation or force a T2TMR count Reset. In Gate modes the counter stops when the gate is disabled and resumes when the gate is enabled. In Reset modes the T2TMR count is reset on either the level or edge from the external source.

The T2TMR and T2PR registers are both directly readable and writable. The T2TMR register is cleared and the T2PR register initializes to FFh on any device Reset. Both the prescaler and postscaler counters are cleared on the following events:

- A write to the T2TMR register
- A write to the T2CON register
- Any device Reset
- External Reset Source event that resets the timer.



**Important:** T2TMR is not cleared when T2CON is written.

#### 27.1.1 Free Running Period Mode

The value of T2TMR is compared to that of the Period register, T2PR, on each clock cycle. When the two values match, the comparator resets the value of T2TMR to 00h on the next cycle and increments the output postscaler counter. When the postscaler count equals the value in the [OUTPS](#) bits of the T2CON



register then a one clock period wide pulse occurs on the TMR2\_postscaled output, and the postscaler count is cleared.

### 27.1.2 One-Shot Mode

The One-Shot mode is identical to the Free Running Period mode except that the ON bit is cleared and the timer is stopped when T2TMR matches T2PR and will not restart until the ON bit is cycled off and on. Postscaler (OUTPS) values other than zero are ignored in this mode because the timer is stopped at the first period event and the postscaler is reset when the timer is restarted.

### 27.1.3 Monostable Mode

Monostable modes are similar to One-Shot modes except that the ON bit is not cleared and the timer can be restarted by an external Reset event.

## 27.2 Timer2 Output

The Timer2 module’s primary output is TMR2\_postscaled, which pulses for a single TMR2\_clk period upon each match of the postscaler counter and the OUTPS bits of the T2CON register. The postscaler is incremented each time the T2TMR value matches the T2PR value. This signal can be selected as an input to several other input modules:

- The ADC module, as an auto-conversion trigger
- CWG, as an auto-shutdown source
- The CRC memory scanner, as a trigger for triggered mode
- Gate source for odd numbered timers (Timer1, Timer3, etc.)
- Alternate SPI clock
- Reset signals for other instances of even numbered timers (Timer2, Timer4, etc.)

In addition, the Timer2 is also used by the CCP module for pulse generation in PWM mode. See “*PWM Overview*” and “*Pulse-width Modulation*” sections for more details on setting up Timer2 for use with the CCP and PWM modules.

#### Related Links

[29.4 PWM Overview](#)

[30. \(PWM\) Pulse-Width Modulation](#)

## 27.3 External Reset Sources

In addition to the clock source, the Timer2 also takes in an external Reset source. This external Reset source is selected for each timer with the corresponding TxRST register. This source can control starting and stopping of the timer, as well as resetting the timer, depending on which mode the timer is in. Reset source selections are shown in the following table.

**Table 27-2. External Reset Sources**

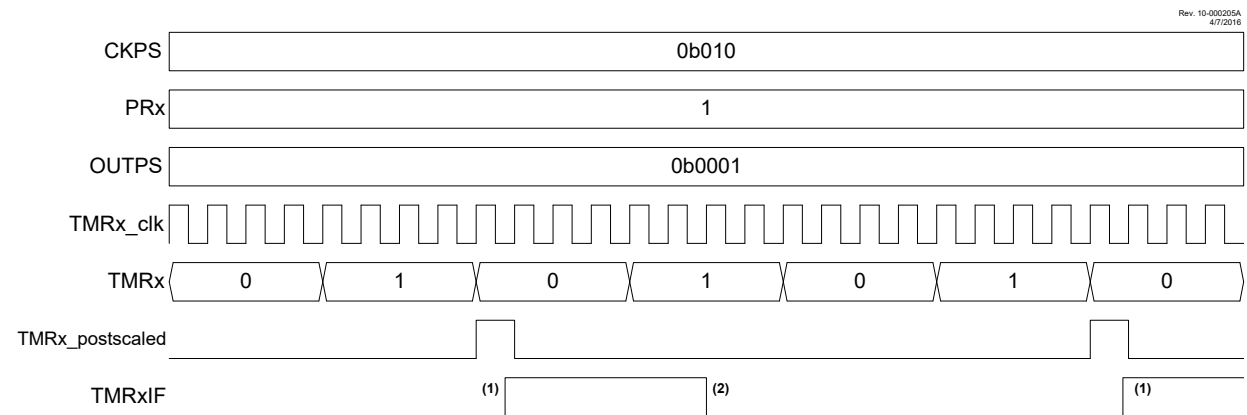
RSEL<3:0>	Reset Source		
	TMR2	TMR4	TMR6
1111	CCP5_out	CCP5_out	CCP5_out
1101	CLC4_out	CLC4_out	CLC4_out

RSEL<3:0>	Reset Source		
	TMR2	TMR4	TMR6
1100	CLC3_out	CLC3_out	CLC3_out
1011	CLC2_out	CLC2_out	CLC2_out
1010	CLC1_out	CLC1_out	CLC1_out
1001	ZCD1_output	ZCD1_output	ZCD1_output
1000	C2OUT_sync	C2OUT_sync	C2OUT_sync
0111	C1OUT_sync	C1OUT_sync	C1OUT_sync
0110	PWM7_out	PWM7_out	PWM7_out
0101	PWM6_out	PWM6_out	PWM6_out
0100	CCP4_out	CCP4_out	CCP4_out
0011	CCP3_out	CCP3_out	CCP3_out
0010	CCP2_out	CCP2_out	CCP2_out
0001	CCP1_out	CCP1_out	CCP1_out
0000	T2INPPS	T4INPPS	T6INPPS

### 27.4 Timer2 Interrupt

Timer2 can also generate a device interrupt. The interrupt is generated when the postscaler counter matches with the selected postscaler value (OUTPS bits of T2CON register). The interrupt is enabled by setting the TMR2IE interrupt enable bit. Interrupt timing is illustrated in the figure below.

**Figure 27-2. Timer2 Prescaler, Postscaler, and Interrupt Timing Diagram**



**Note:**

1. Setting the interrupt flag is synchronized with the instruction clock.
2. Cleared by software.

### 27.5 Operating Modes

The mode of the timer is controlled by the **MODE** bits of the **T2HLT** register. Edge-Triggered modes require six Timer clock periods between external triggers. Level-Triggered modes require the triggering level to be at least three Timer clock periods long. External triggers are ignored while in Debug mode.

**Table 27-3. Operating Modes Table**

Mode	MODE<4:0>		Output Operation	Operation	Timer Control			
	<4:3>	<2:0>			Start	Reset	Stop	
Free Running Period	00	000	Period Pulse	Software gate (Figure 27-3)	ON = 1	—	ON = 0	
		001		Hardware gate, active-high (Figure 27-4)	ON = 1 and TMRx_ers = 1	—	ON = 0 or TMRx_ers = 0	
		010		Hardware gate, active-low	ON = 1 and TMRx_ers = 0	—	ON = 0 or TMRx_ers = 1	
		011	Period Pulse with Hardware Reset	Rising or falling edge Reset	ON = 1	TMRx_ers ↓	ON = 0	
		100		Rising edge Reset (Figure 27-5)		TMRx_ers ↑		
		101		Falling edge Reset		TMRx_ers ↓		
		110		Low level Reset		TMRx_ers = 0		ON = 0 or TMRx_ers = 0
		111		High level Reset (Figure 27-6)		TMRx_ers = 1		ON = 0 or TMRx_ers = 1
One-shot	01	000	One-shot	Software start (Figure 27-7)	ON = 1	—	ON = 0 or Next clock after TMRx = PRx (Note 2)	
		001	Edge Triggered Start (Note 1)	Rising edge start (Figure 27-8)	ON = 1 and TMRx_ers ↑	—		
		010		Falling edge start	ON = 1 and TMRx_ers ↓	—		
		011		Any edge start	ON = 1 and TMRx_ers ↓	—		

Mode	MODE<4:0>		Output Operation	Operation	Timer Control		
	<4:3>	<2:0>			Start	Reset	Stop
		100	Edge Triggered Start and Hardware Reset (Note 1)	Rising edge start and Rising edge Reset (Figure 27-9)	ON = 1 and TMRx_ers ↑	TMRx_ers ↑	
		101		Falling edge start and Falling edge Reset	ON = 1 and TMRx_ers ↓	TMRx_ers ↓	
		110		Rising edge start and Low level Reset (Figure 27-10)	ON = 1 and TMRx_ers ↑	TMRx_ers = 0	
		111		Falling edge start and High level Reset	ON = 1 and TMRx_ers ↓	TMRx_ers = 1	
Mono-stable	10	000	Reserved				
		001	Edge Triggered Start (Note 1)	Rising edge start (Figure 27-11)	ON = 1 and TMRx_ers ↑	—	ON = 0 or Next clock after TMRx = PRx (Note 3)
		010		Falling edge start	ON = 1 and TMRx_ers ↓	—	
		011		Any edge start	ON = 1 and TMRx_ers ↓	—	
Reserved	100	Reserved					
Reserved	101	Reserved					
One-shot	10	110	Level Triggered Start and Hardware Reset	High level start and Low level Reset (Figure 27-12)	ON = 1 and TMRx_ers = 1	TMRx_ers = 0	ON = 0 or Held in Reset (Note 2)
		111		Low level start & High level Reset	ON = 1 and TMRx_ers = 0	TMRx_ers = 1	

Mode	MODE<4:0>		Output Operation	Operation	Timer Control		
	<4:3>	<2:0>			Start	Reset	Stop
Reserved	11	xxx			Reserved		

**Note:**

1. If ON = 0 then an edge is required to restart the timer after ON = 1.
2. When T2TMR = T2PR then the next clock clears ON and stops T2TMR at 00h.
3. When T2TMR = T2PR then the next clock stops T2TMR at 00h but does not clear ON.

## 27.6 Operation Examples

Unless otherwise specified, the following notes apply to the following timing diagrams:

- Both the prescaler and postscaler are set to 1:1 (both the CKPS and OUTPS bits in the T2CON register are cleared).
- The diagrams illustrate any clock except  $F_{OSC}/4$  and show clock-sync delays of at least two full cycles for both ON and Timer2\_ers. When using  $F_{OSC}/4$ , the clock-sync delay is at least one instruction period for Timer2\_ers; ON applies in the next instruction period.
- ON and Timer2\_ers are somewhat generalized, and clock-sync delays may produce results that are slightly different than illustrated.
- The PWM Duty Cycle and PWM output are illustrated assuming that the timer is used for the PWM function of the CCP module as described in the “PWM Overview” section. The signals are not a part of the Timer2 module.

**Related Links**

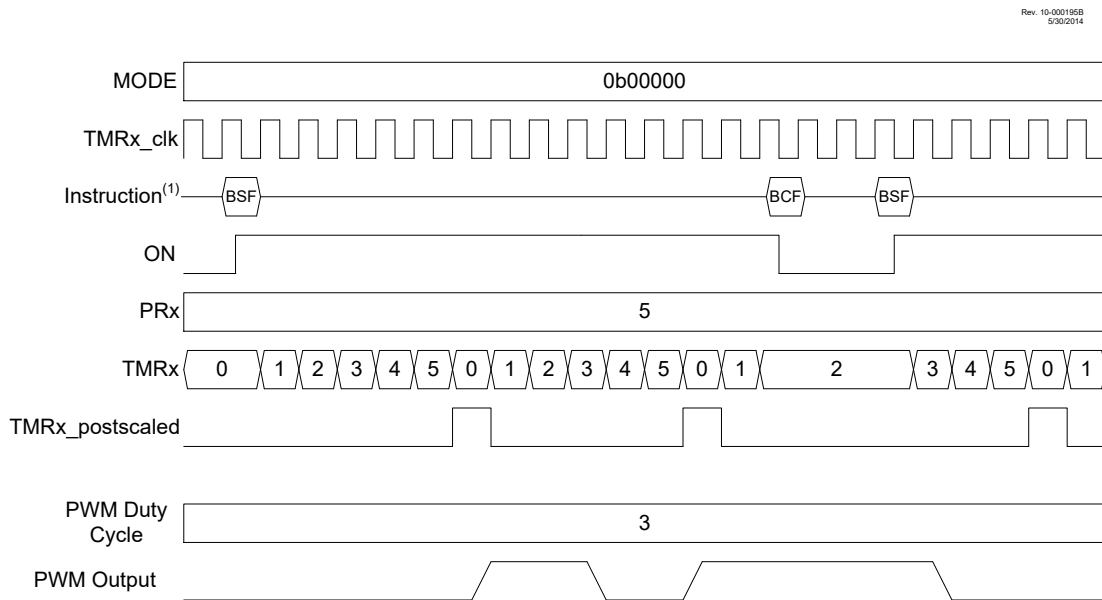
[29.4 PWM Overview](#)

[30. \(PWM\) Pulse-Width Modulation](#)

### 27.6.1 Software Gate Mode

This mode corresponds to legacy Timer2 operation. The timer increments with each clock input when ON = 1 and does not increment when ON = 0. When the TMRx count equals the PRx period count the timer resets on the next clock and continues counting from 0. Operation with the ON bit software controlled is illustrated in [Figure 27-3](#). With PRx = 5, the counter advances until TMRx = 5, and goes to zero with the next clock.

Figure 27-3. Software Gate Mode Timing Diagram (MODE = 00000)



**Note:**

1. BSF and BCF represent Bit-Set File and Bit-Clear File instructions executed by the CPU to set or clear the ON bit of TxCON. CPU execution is asynchronous to the timer clock input.

**Related Links**

- [29.4 PWM Overview](#)
- [30. \(PWM\) Pulse-Width Modulation](#)

**27.6.2 Hardware Gate Mode**

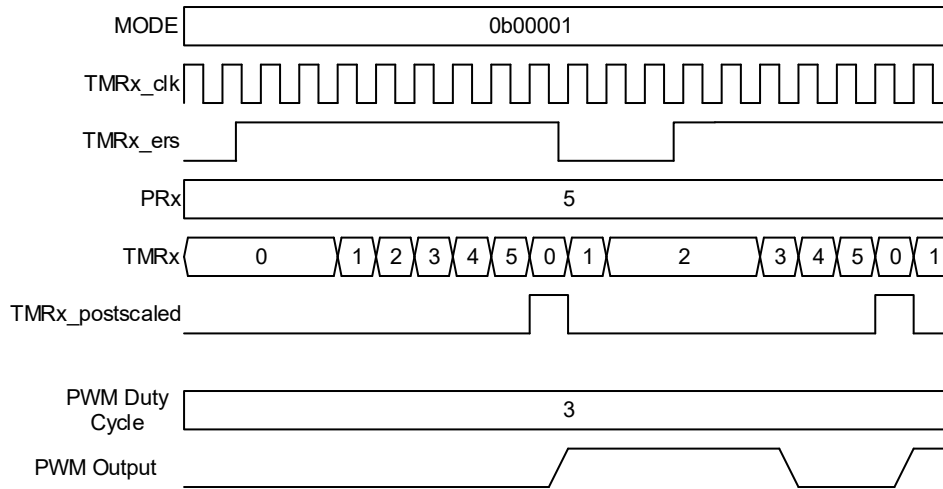
The Hardware Gate modes operate the same as the Software Gate mode except the TMRx\_ers external signal can also gate the timer. When used with the CCP, the gating extends the PWM period. If the timer is stopped when the PWM output is high, then the duty cycle is also extended.

When MODE<4:0> = 00001 then the timer is stopped when the external signal is high. When MODE<4:0> = 00010, then the timer is stopped when the external signal is low.

Figure 27-4 illustrates the Hardware Gating mode for MODE<4:0> = 00001 in which a high input level starts the counter.

Figure 27-4. Hardware Gate Mode Timing Diagram (MODE = 00001)

Rev. 10-001-198B  
5/30/2014



#### Related Links

[29.4 PWM Overview](#)

[30. \(PWM\) Pulse-Width Modulation](#)

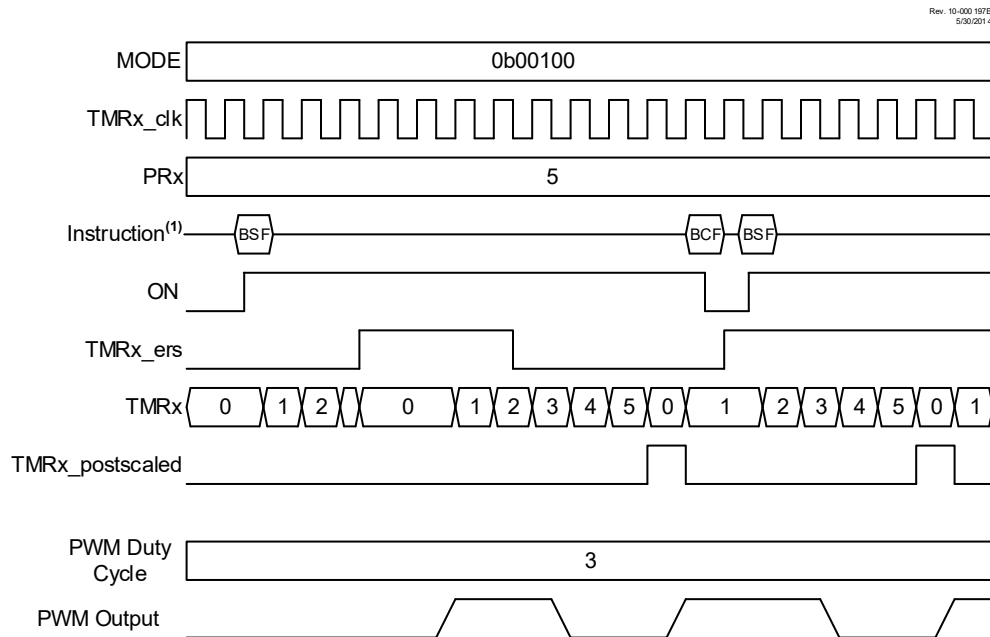
#### 27.6.3 Edge-Triggered Hardware Limit Mode

In Hardware Limit mode, the timer can be reset by the TMRx\_ers external signal before the timer reaches the period count. Three types of Resets are possible:

- Reset on rising or falling edge (MODE<4:0>= 00011)
- Reset on rising edge (MODE<4:0> = 00100)
- Reset on falling edge (MODE<4:0> = 00101)

When the timer is used in conjunction with the CCP in PWM mode then an early Reset shortens the period and restarts the PWM pulse after a two clock delay. Refer to [Figure 27-5](#).

**Figure 27-5. Edge-Triggered Hardware Limit Mode Timing Diagram (MODE = 00100)**



**Note:**

1. BSF and BCF represent Bit-Set File and Bit-Clear File instructions executed by the CPU to set or clear the ON bit of TxCON. CPU execution is asynchronous to the timer clock input.

**Related Links**

- [29.4 PWM Overview](#)
- [30. \(PWM\) Pulse-Width Modulation](#)

**27.6.4 Level-Triggered Hardware Limit Mode**

In the Level-Triggered Hardware Limit Timer modes the counter is reset by high or low levels of the external signal TMRx\_ers, as shown in [Figure 27-6](#). Selecting MODE<4:0> = 00110 will cause the timer to reset on a low level external signal. Selecting MODE<4:0> = 00111 will cause the timer to reset on a high level external signal. In the example, the counter is reset while TMRx\_ers = 1. ON is controlled by BSF and BCF instructions. When ON = 0 the external signal is ignored.

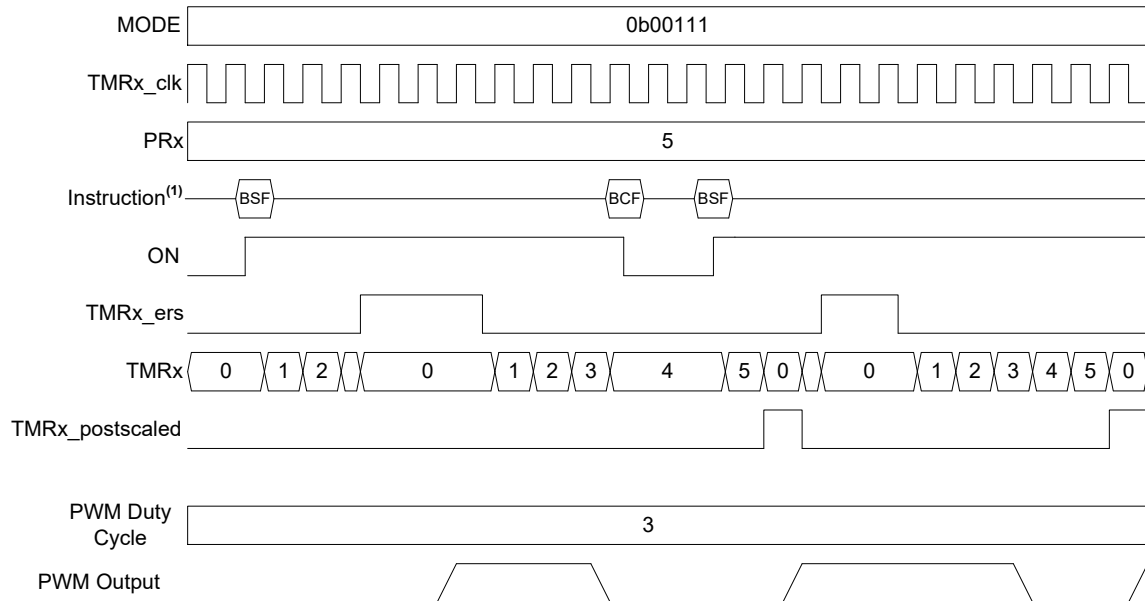
When the CCP uses the timer as the PWM time base then the PWM output will be set high when the timer starts counting and then set low only when the timer count matches the CCPRx value. The timer is reset when either the timer count matches the PRx value or two clock periods after the external Reset signal goes true and stays true.

The timer starts counting, and the PWM output is set high, on either the clock following the PRx match or two clocks after the external Reset signal relinquishes the Reset. The PWM output will remain high until the timer counts up to match the CCPRx pulse width value. If the external Reset signal goes true while the PWM output is high then the PWM output will remain high until the Reset signal is released allowing the timer to count up to match the CCPRx value.



Figure 27-6. Level-Triggered Hardware Limit Mode Timing Diagram (MODE = 00111)

Rev. 10-000198B  
5/30/2014



**Note:**

1. BSF and BCF represent Bit-Set File and Bit-Clear File instructions executed by the CPU to set or clear the ON bit of TxCON. CPU execution is asynchronous to the timer clock input.

**Related Links**

- [29.4 PWM Overview](#)
- [30. \(PWM\) Pulse-Width Modulation](#)

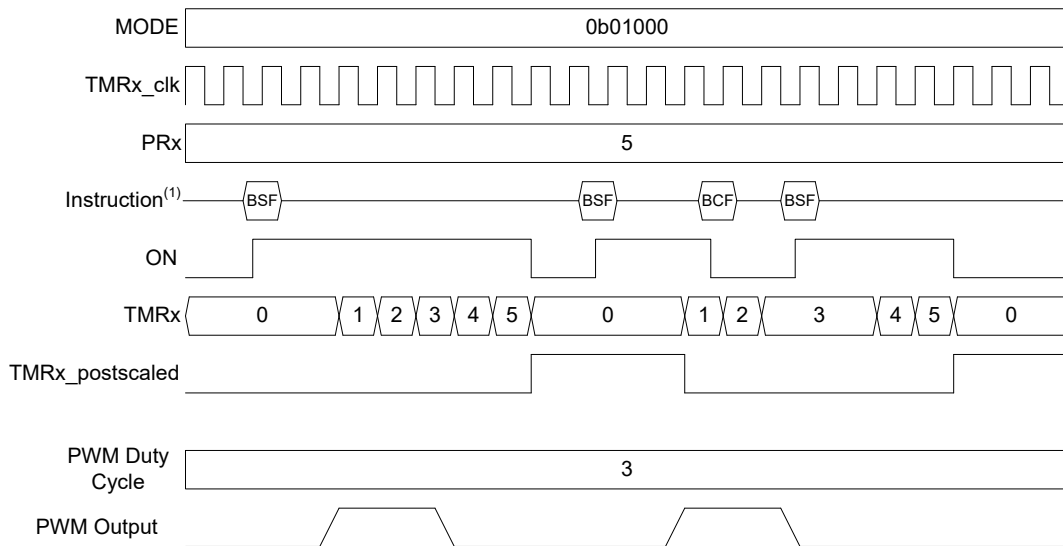
**27.6.5 Software Start One-Shot Mode**

In One-Shot mode the timer resets and the ON bit is cleared when the timer value matches the PRx period value. The ON bit must be set by software to start another timer cycle. Setting MODE<4:0> = 01000 selects One-Shot mode which is illustrated in Figure 27-7. In the example, ON is controlled by BSF and BCF instructions. In the first case, a BSF instruction sets ON and the counter runs to completion and clears ON. In the second case, a BSF instruction starts the cycle, BCF/BSF instructions turn the counter off and on during the cycle, and then it runs to completion.

When One-Shot mode is used in conjunction with the CCP PWM operation the PWM pulse drive starts concurrent with setting the ON bit. Clearing the ON bit while the PWM drive is active will extend the PWM drive. The PWM drive will terminate when the timer value matches the CCPRx pulse width value. The PWM drive will remain off until software sets the ON bit to start another cycle. If software clears the ON bit after the CCPRx match but before the PRx match then the PWM drive will be extended by the length of time the ON bit remains cleared. Another timing cycle can only be initiated by setting the ON bit after it has been cleared by a PRx period count match.

Figure 27-7. Software Start One-shot Mode Timing Diagram (MODE = 01000)

Rev. 10-000196B  
4/7/2016



**Note:**

1. BSF and BCF represent Bit-Set File and Bit-Clear File instructions executed by the CPU to set or clear the ON bit of TxCON. CPU execution is asynchronous to the timer clock input.

**Related Links**

- [29.4 PWM Overview](#)
- [30. \(PWM\) Pulse-Width Modulation](#)

**27.6.6 Edge-Triggered One-Shot Mode**

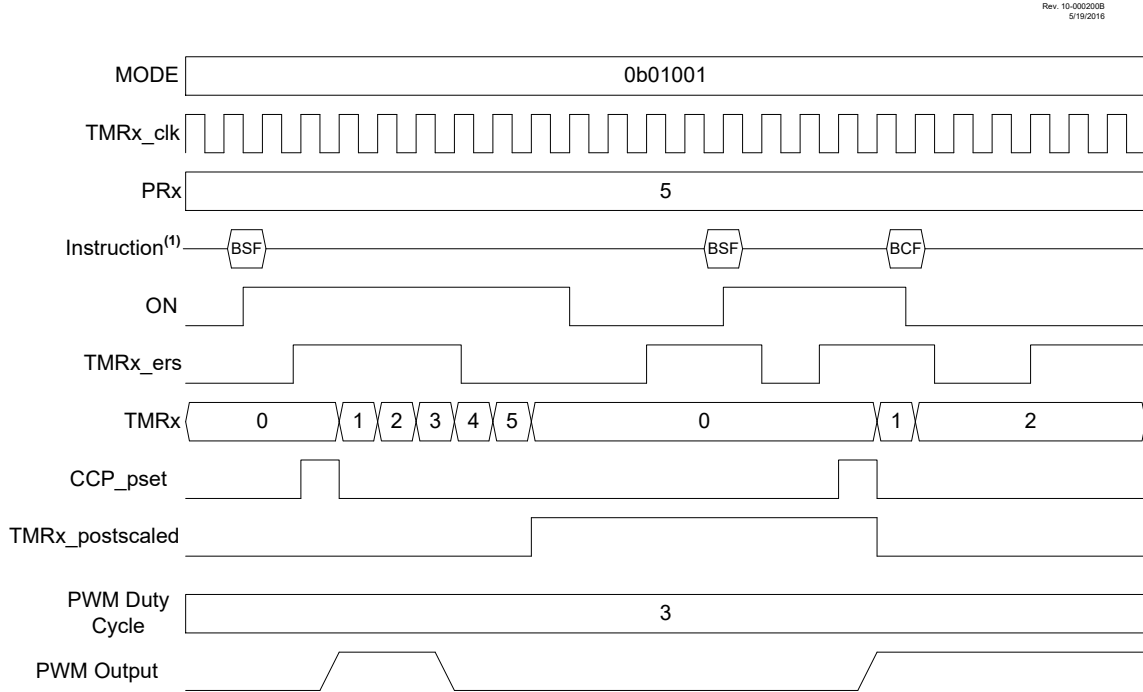
The Edge-Triggered One-Shot modes start the timer on an edge from the external signal input, after the ON bit is set, and clear the ON bit when the timer matches the PRx period value. The following edges will start the timer:

- Rising edge (MODE<4:0> = 01001)
- Falling edge (MODE<4:0> = 01010)
- Rising or Falling edge (MODE<4:0> = 01011)

If the timer is halted by clearing the ON bit then another TMRx\_ers edge is required after the ON bit is set to resume counting. [Figure 27-8](#) illustrates operation in the rising edge One-Shot mode.

When Edge-Triggered One-Shot mode is used in conjunction with the CCP then the edge-trigger will activate the PWM drive and the PWM drive will deactivate when the timer matches the CCPRx pulse width value and stay deactivated when the timer halts at the PRx period count match.

Figure 27-8. Edge-Triggered One-Shot Mode Timing Diagram (MODE = 01001)



**Note:**

1. BSF and BCF represent Bit-Set File and Bit-Clear File instructions executed by the CPU to set or clear the ON bit of TxCON. CPU execution is asynchronous to the timer clock input.

**Related Links**

- [29.4 PWM Overview](#)
- [30. \(PWM\) Pulse-Width Modulation](#)

**27.6.7 Edge-Triggered Hardware Limit One-Shot Mode**

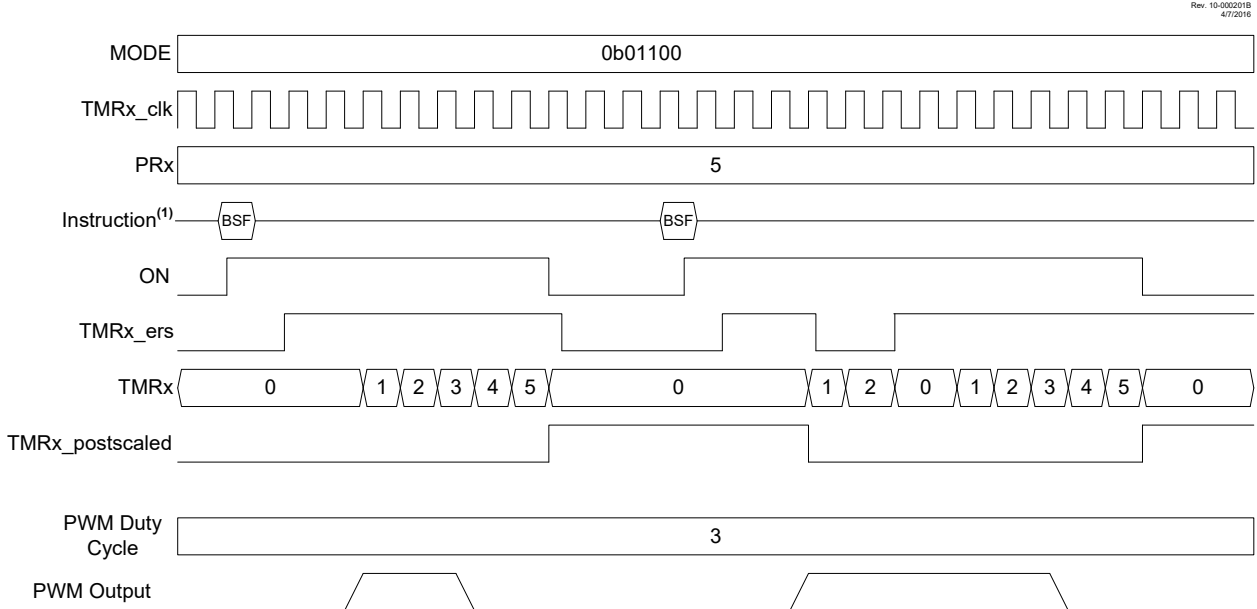
In Edge-Triggered Hardware Limit One-Shot modes the timer starts on the first external signal edge after the ON bit is set and resets on all subsequent edges. Only the first edge after the ON bit is set is needed to start the timer. The counter will resume counting automatically two clocks after all subsequent external Reset edges. Edge triggers are as follows:

- Rising edge start and Reset (MODE<4:0> = 01100)
- Falling edge start and Reset (MODE<4:0> = 01101)

The timer resets and clears the ON bit when the timer value matches the PRx period value. External signal edges will have no effect until after software sets the ON bit. [Figure 27-9](#) illustrates the rising edge hardware limit one-shot operation.

When this mode is used in conjunction with the CCP then the first starting edge trigger, and all subsequent Reset edges, will activate the PWM drive. The PWM drive will deactivate when the timer matches the CCPRx pulse-width value and stay deactivated until the timer halts at the PRx period match unless an external signal edge resets the timer before the match occurs.

Figure 27-9. Edge-Triggered Hardware Limit One-Shot Mode Timing Diagram (MODE = 011100)



**Note:**

1. BSF and BCF represent Bit-Set File and Bit-Clear File instructions executed by the CPU to set or clear the ON bit of TxCON. CPU execution is asynchronous to the timer clock input.

**Related Links**

- [29.4 PWM Overview](#)
- [30. \(PWM\) Pulse-Width Modulation](#)

**27.6.8 Level Reset, Edge-Triggered Hardware Limit One-Shot Modes**

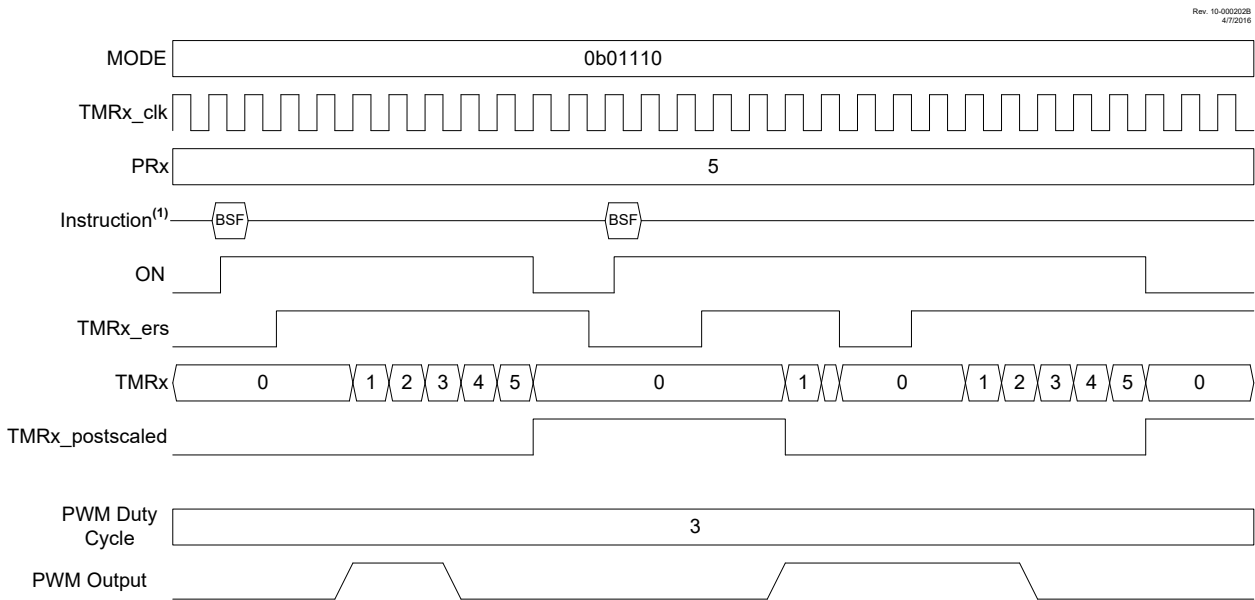
In Level -Triggered One-Shot mode the timer count is reset on the external signal level and starts counting on the rising/falling edge of the transition from Reset level to the active level while the ON bit is set. Reset levels are selected as follows:

- Low Reset level (MODE<4:0> = 01110)
- High Reset level (MODE<4:0> = 01111)

When the timer count matches the PRx period count, the timer is reset and the ON bit is cleared. When the ON bit is cleared by either a PRx match or by software control, a new external signal edge is required after the ON bit is set to start the counter.

When Level-Triggered Reset One-Shot mode is used in conjunction with the CCP PWM operation, the PWM drive goes active with the external signal edge that starts the timer. The PWM drive goes inactive when the timer count equals the CCPRx pulse width count. The PWM drive does not go active when the timer count clears at the PRx period count match.

**Figure 27-10. Low Level Reset, Edge-Triggered hardware Limit one-Shot Mode Timing Diagram (MODE = 01110)**



**Note:**

1. BSF and BCF represent Bit-Set File and Bit-Clear File instructions executed by the CPU to set or clear the ON bit of TxCON. CPU execution is asynchronous to the timer clock input.

**Related Links**

- [29.4 PWM Overview](#)
- [30. \(PWM\) Pulse-Width Modulation](#)

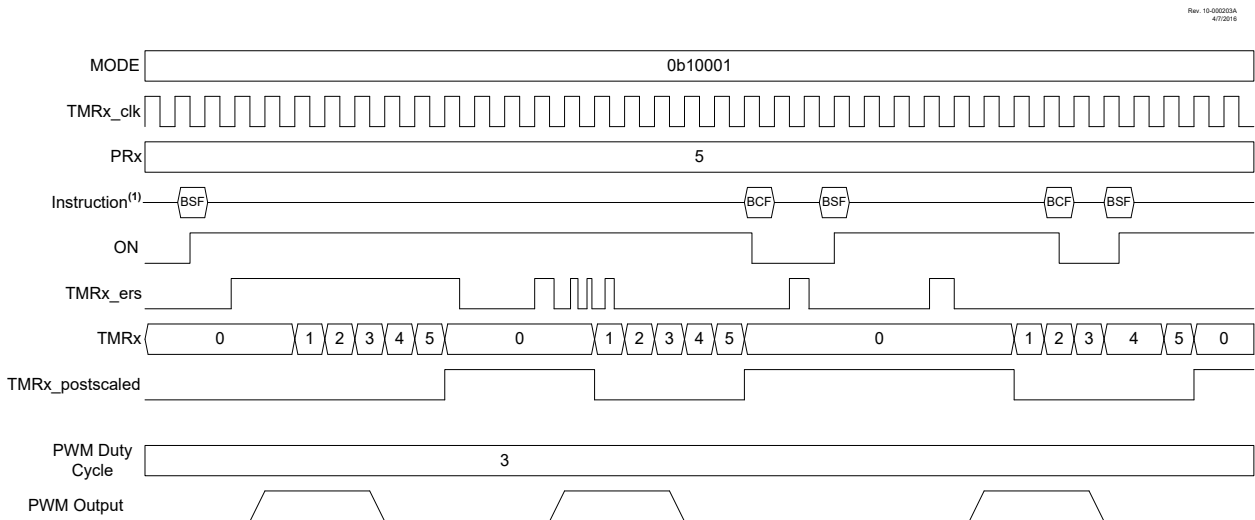
**27.6.9 Edge-Triggered Monostable Modes**

The Edge-Triggered Monostable modes start the timer on an edge from the external Reset signal input, after the ON bit is set, and stop incrementing the timer when the timer matches the PRx period value. The following edges will start the timer:

- Rising edge (MODE<4:0> = 10001)
- Falling edge (MODE<4:0> = 10010)
- Rising or Falling edge (MODE<4:0> = 10011)

When an Edge-Triggered Monostable mode is used in conjunction with the CCP PWM operation, the PWM drive goes active with the external Reset signal edge that starts the timer, but will not go active when the timer matches the PRx value. While the timer is incrementing, additional edges on the external Reset signal will not affect the CCP PWM.

**Figure 27-11. Rising Edge-Triggered Monostable Mode Timing Diagram (MODE = 10001)**



**Note:**

1. BSF and BCF represent Bit-Set File and Bit-Clear File instructions executed by the CPU to set or clear the ON bit of TxCON. CPU execution is asynchronous to the timer clock input.

**Related Links**

[29.4 PWM Overview](#)

[30. \(PWM\) Pulse-Width Modulation](#)

### 27.6.10 Level-Triggered Hardware Limit One-Shot Modes

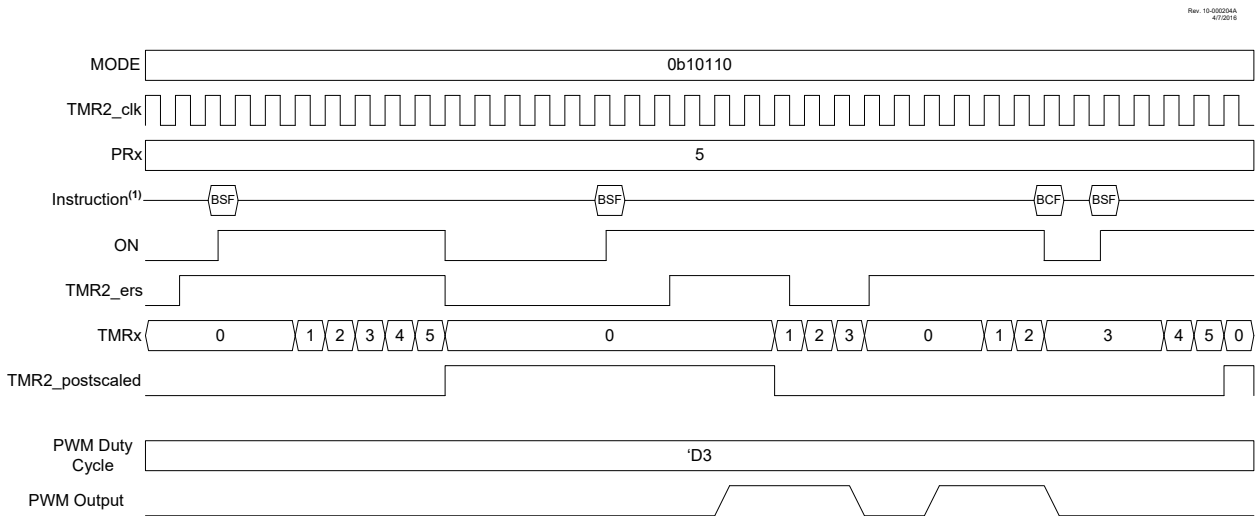
The Level-Triggered Hardware Limit One-Shot modes hold the timer in Reset on an external Reset level and start counting when both the ON bit is set and the external signal is not at the Reset level. If one of either the external signal is not in Reset or the ON bit is set, then the other signal being set/made active will start the timer. Reset levels are selected as follows:

- Low Reset level (MODE<4:0> = 10110)
- High Reset level (MODE<4:0> = 10111)

When the timer count matches the PRx period count, the timer is reset and the ON bit is cleared. When the ON bit is cleared by either a PRx match or by software control, the timer will stay in Reset until both the ON bit is set and the external signal is not at the Reset level.

When Level-Triggered Hardware Limit One-Shot modes are used in conjunction with the CCP PWM operation, the PWM drive goes active with either the external signal edge or the setting of the ON bit, whichever of the two starts the timer.

**Figure 27-12. Level-Triggered hardware Limit one-Shot Mode Timing Diagram (MODE = 10110)**



**Note:**

1. BSF and BCF represent Bit-Set File and Bit-Clear File instructions executed by the CPU to set or clear the ON bit of TxCON. CPU execution is asynchronous to the timer clock input.

**Related Links**

[29.4 PWM Overview](#)

[30. \(PWM\) Pulse-Width Modulation](#)

### 27.7 Timer2 Operation During Sleep

When **PSYNC** = 1, Timer2 cannot be operated while the processor is in Sleep mode. The contents of the T2TMR and T2PR registers will remain unchanged while processor is in Sleep mode.

When **PSYNC** = 0, Timer2 will operate in Sleep as long as the clock source selected is also still running. If any internal oscillator is selected as the clock source, it will stay active during Sleep mode.

## 27.8 Register Summary - Timer2

Address	Name	Bit Pos.							
0x028C	T2TMR	7:0	TxTMR[7:0]						
0x028D	T2PR	7:0	TxPR[7:0]						
0x028E	T2CON	7:0	ON	CKPS[2:0]			OUTPS[3:0]		
0x028F	T2HLT	7:0	PSYNC	CPOL	CSYNC	MODE[4:0]			
0x0290	T2CLKCON	7:0				CS[3:0]			
0x0291	T2RST	7:0				RSEL[3:0]			
0x0292	T4TMR	7:0	TxTMR[7:0]						
0x0293	T4PR	7:0	TxPR[7:0]						
0x0294	T4CON	7:0	ON	CKPS[2:0]			OUTPS[3:0]		
0x0295	T4HLT	7:0	PSYNC	CPOL	CSYNC	MODE[4:0]			
0x0296	T4CLKCON	7:0				CS[3:0]			
0x0297	T4RST	7:0				RSEL[3:0]			
0x0298	T6TMR	7:0	TxTMR[7:0]						
0x0299	T6PR	7:0	TxPR[7:0]						
0x029A	T6CON	7:0	ON	CKPS[2:0]			OUTPS[3:0]		
0x029B	T6HLT	7:0	PSYNC	CPOL	CSYNC	MODE[4:0]			
0x029C	T6CLKCON	7:0				CS[3:0]			
0x029D	T6RST	7:0				RSEL[3:0]			

## 27.9 Register Definitions: Timer2 Control

Long bit name prefixes for the Timer2 peripherals are shown in table below. Refer to Section "Long Bit Names" for more information.

**Table 27-4. Timer2 long bit name prefixes**

Peripheral	Bit Name Prefix
Timer2	T2
Timer4	T4
Timer6	T6



**Notice:** References to module Timer2 apply to all the even numbered timers on this device. (Timer2, Timer4, etc.)

### Related Links

[1.4.2.2 Long Bit Names](#)



27.9.1 TxTMR

**Name:** TxTMR

**Address:** 0x28C,0x292,0x298

Timer Counter Register

Bit	7	6	5	4	3	2	1	0
	TxTMR[7:0]							
Access	R/W	R/W	R/W	R/W	R/W	R/W	R/W	R/W
Reset	0	0	0	0	0	0	0	0

**Bits 7:0 – TxTMR[7:0]** Timerx Counter bits

27.9.2 TxPR

**Name:** TxPR

**Address:** 0x28D,0x293,0x299

Timer Period Register

Bit	7	6	5	4	3	2	1	0
	TxPR[7:0]							
Access	R/W	R/W	R/W	R/W	R/W	R/W	R/W	R/W
Reset	1	1	1	1	1	1	1	1

**Bits 7:0 – TxPR[7:0]** Timer Period Register bits

Value	Description
0 – 255	The timer restarts at '0' when TxTMR reaches TxPR value

27.9.3 TxCON

**Name:** TxCON  
**Address:** 0x28E,0x294,0x29A

Timerx Control Register

Bit	7	6	5	4	3	2	1	0
	ON	CKPS[2:0]			OUTPS[3:0]			
Access	R/W/HC	R/W	R/W	R/W	R/W	R/W	R/W	R/W
Reset	0	0	0	0	0	0	0	0

**Bit 7 – ON**  
 Timer On bit<sup>(1)</sup>

Value	Description
1	Timer is on
0	Timer is off: all counters and state machines are reset

**Bits 6:4 – CKPS[2:0]** Timer Clock Prescale Select bits

Value	Description
111	1:128 Prescaler
110	1:64 Prescaler
101	1:32 Prescaler
100	1:16 Prescaler
011	1:8 Prescaler
010	1:4 Prescaler
001	1:2 Prescaler
000	1:1 Prescaler

**Bits 3:0 – OUTPS[3:0]** Timer Output Postscaler Select bits

Value	Description
1111	1:16 Postscaler
1110	1:15 Postscaler
1101	1:14 Postscaler
1100	1:13 Postscaler
1011	1:12 Postscaler
1010	1:11 Postscaler
1001	1:10 Postscaler
1000	1:9 Postscaler
0111	1:8 Postscaler
0110	1:7 Postscaler
0101	1:6 Postscaler
0100	1:5 Postscaler
0011	1:4 Postscaler
0010	1:3 Postscaler

---

---

Value	Description
0001	1:2 Postscaler
0000	1:1 Postscaler

**Note:**

1. In certain modes, the ON bit will be auto-cleared by hardware. See [Table 27-3](#).

27.9.4 TxHLT

**Name:** TxHLT  
**Address:** 0x28F,0x295,0x29B

Timer Hardware Limit Control Register

Bit	7	6	5	4	3	2	1	0
	PSYNC	CPOL	CSYNC	MODE[4:0]				
Access	R/W	R/W	R/W	R/W	R/W	R/W	R/W	R/W
Reset	0	0	0	0	0	0	0	0

**Bit 7 – PSYNC**

Timer Prescaler Synchronization Enable bit<sup>(1, 2)</sup>

Value	Description
1	Timer Prescaler Output is synchronized to $F_{OSC}/4$
0	Timer Prescaler Output is not synchronized to $F_{OSC}/4$

**Bit 6 – CPOL**

Timer Clock Polarity Selection bit<sup>(3)</sup>

Value	Description
1	Falling edge of input clock clocks timer/prescaler
0	Rising edge of input clock clocks timer/prescaler

**Bit 5 – CSYNC**

Timer Clock Synchronization Enable bit<sup>(4, 5)</sup>

Value	Description
1	ON bit is synchronized to timer clock input
0	ON bit is not synchronized to timer clock input

**Bits 4:0 – MODE[4:0]**

Timer Control Mode Selection bits<sup>(6, 7)</sup>

Value	Description
00000 to 11111	See <a href="#">Table 27-3</a>

**Note:**

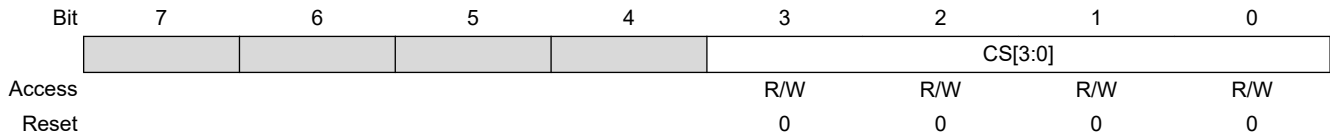
- Setting this bit ensures that reading TxTMR will return a valid data value.
- When this bit is '1', Timer cannot operate in Sleep mode.
- CKPOL should not be changed while ON = 1.
- Setting this bit ensures glitch-free operation when the ON is enabled or disabled.
- When this bit is set then the timer operation will be delayed by two input clocks after the ON bit is set.
- Unless otherwise indicated, all modes start upon ON = 1 and stop upon ON = 0 (stops occur without affecting the value of TxTMR).

7. When  $TxTMR = TxPR$ , the next clock clears  $TxTMR$ , regardless of the operating mode.

27.9.5 TxCLKCON

**Name:** TxCLKCON  
**Address:** 0x290,0x296,0x29C

Timer Clock Source Selection Register



**Bits 3:0 – CS[3:0]** Timer Clock Source Selection bits

Value	Description
n	See <a href="#">Clock Source Selection</a> table

**27.9.6 TxRST**

**Name:** TxRST

**Address:** 0x291,0x297,0x29D

Timer External Reset Signal Selection Register

Bit	7	6	5	4	3	2	1	0
					RSEL[3:0]			
Access					R/W	R/W	R/W	R/W
Reset					0	0	0	0

**Bits 3:0 – RSEL[3:0]**

External Reset Source Selection Bits

Value	Description
n	See <a href="#">External Reset Sources</a> table



## **28. CCP/PWM Timer Resource Selection**

Each CCP/PWM module has an independent timer selection which can be accessed using the CxTSEL or PxTSEL bits in the [CCPTMRS0](#) and/or [CCPTMRS1](#) registers. The default timer selection is TMR1 when using Capture/Compare mode and T2TMR when using PWM mode in the CCPx module. The default timer selection for the PWM module is always T2TMR.

### 28.1 Register Summary - Timer Selection Registers for CCP/PWM

Address	Name	Bit Pos.					
0x021E	<a href="#">CCPTMRS0</a>	7:0	C4TSEL[1:0]	C3TSEL[1:0]	C2TSEL[1:0]	C1TSEL[1:0]	
0x021F	<a href="#">CCPTMRS1</a>	7:0		P7TSEL[1:0]	P6TSEL[1:0]		

### 28.2 Register Definitions: CCP/PWM Timer Selection

**28.2.1 CCPTMRS0**

**Name:** CCPTMRS0  
**Address:** 0x21E

CCP Timers Selection Register0

Bit	7	6	5	4	3	2	1	0
	C4TSEL[1:0]		C3TSEL[1:0]		C2TSEL[1:0]		C1TSEL[1:0]	
Access	R/W	R/W	R/W	R/W	R/W	R/W	R/W	R/W
Reset	0	1	0	1	0	1	0	1

**Bits 0:1, 2:3, 4:5, 6:7 – CxTSEL** CCPx Timer Selection bits

Value	Description
11	CCPx is based off Timer5 in Capture/Compare mode and Timer6 in PWM mode
10	CCPx is based off Timer3 in Capture/Compare mode and Timer4 in PWM mode
01	CCPx is based off Timer1 in Capture/Compare mode and Timer2 in PWM mode
00	Reserved

**28.2.2 CCPTMRS1**

**Name:** CCPTMRS1

**Address:** 0x21F

CCP Timers Control Register

	Bit	7	6	5	4	3	2	1	0
				P7TSEL[1:0]		P6TSEL[1:0]			
Access				R/W	R/W	R/W	R/W		
Reset				0	1	0	1		

**Bits 2:3, 4:5 – PxTSEL** PWMx Timer Selection bits

Value	Description
11	PWMx based on TMR6
10	PWMx based on TMR4
01	PWMx based on TMR2
00	Reserved

## 29. Capture/Compare/PWM Module

The Capture/Compare/PWM module is a peripheral that allows the user to time and control different events, and to generate Pulse-Width Modulation (PWM) signals. In Capture mode, the peripheral allows the timing of the duration of an event. The Compare mode allows the user to trigger an external event when a predetermined amount of time has expired. The PWM mode can generate Pulse-Width Modulated signals of varying frequency and duty cycle.

This family of devices contains five standard Capture/Compare/PWM modules (CCP1, CCP2, CCP3, CCP4 and CCP5). It should be noted that the Capture/Compare mode operation is described with respect to TMR1 and the PWM mode operation is described with respect to T2TMR in the following sections.

The Capture and Compare functions are identical for all CCP modules.



### Important:

1. In devices with more than one CCP module, it is very important to pay close attention to the register names used. A number placed after the module acronym is used to distinguish between separate modules. For example, the CCP1CON and CCP2CON control the same operational aspects of two completely different CCP modules.
2. Throughout this section, generic references to a CCP module in any of its operating modes may be interpreted as being equally applicable to CCPx module. Register names, module signals, I/O pins, and bit names may use the generic designator 'x' to indicate the use of a numeral to distinguish a particular module, when required.

### 29.1 CCP Module Configuration

Each Capture/Compare/PWM module is associated with a control register ([CCPxCON](#)), a capture input selection register ([CCPxCAP](#)) and a data register ([CCPRx](#)). The data register, in turn, is comprised of two 8-bit registers: CCPRxL (low byte) and CCPRxH (high byte).

#### 29.1.1 CCP Modules and Timer Resources

The CCP modules utilize Timers 1 through 6 that vary with the selected mode. Various timers are available to the CCP modules in Capture, Compare or PWM modes, as shown in the table below.

**Table 29-1. CCP Mode - Timer Resources**

CCP Mode	Timer Resource
Capture	Timer1, Timer3 or Timer5
Compare	
PWM	Timer2, Timer4 or Timer6

The assignment of a particular timer to a module is determined by the timer to CCP enable bits in the [CCPTMRS0](#) and/or [CCPTMRS1](#) registers. All of the modules may be active at once and may share the same timer resource if they are configured to operate in the same mode (Capture/Compare or PWM) at the same time.

### 29.1.2 Open-Drain Output Option

When operating in Output mode (the Compare or PWM modes), the drivers for the CCPx pins can be optionally configured as open-drain outputs. This feature allows the voltage level on the pin to be pulled to a higher level through an external pull-up resistor and allows the output to communicate with external circuits without the need for additional level shifters.

## 29.2 Capture Mode

Capture mode makes use of the 16-bit odd numbered timer resources (Timer1, Timer3, etc.). When an event occurs on the capture source, the 16-bit CCPRx register captures and stores the 16-bit value of the TMRx register. An event is defined as one of the following and is configured by the **MODE** bits:

- Every falling edge of CCPx input
- Every rising edge of CCPx input
- Every 4<sup>th</sup> rising edge of CCPx input
- Every 16<sup>th</sup> rising edge of CCPx input
- Every edge of CCPx input (rising or falling)

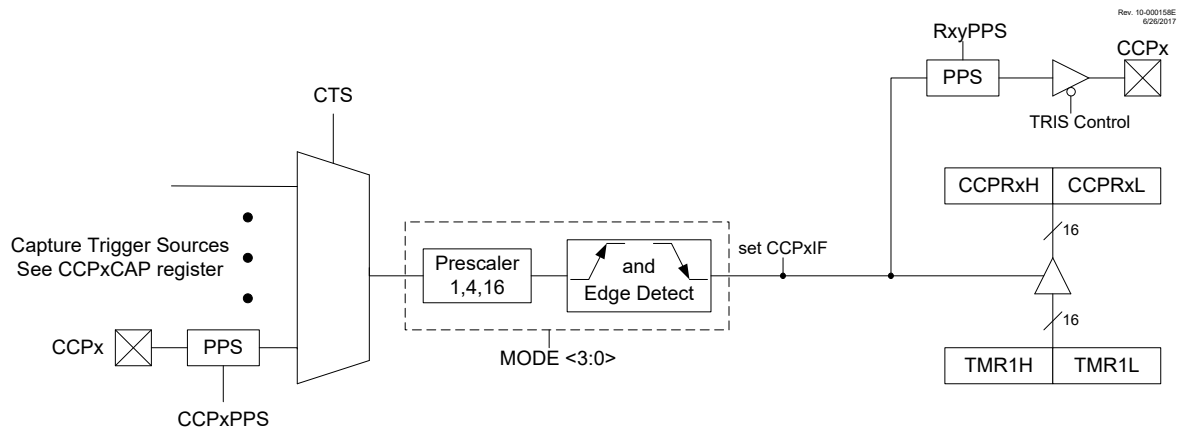
When a capture is made, the Interrupt Request Flag bit CCPxIF of the PIRx register is set. The interrupt flag must be cleared in software. If another capture occurs before the value in the CCPRx register is read, the old captured value is overwritten by the new captured value.



**Important:** If an event occurs during a 2-byte read, the high and low-byte data will be from different events. It is recommended while reading the CCPRxH:CCPRxL register pair to either disable the module or read the register pair twice for data integrity.

The following figure shows a simplified diagram of the capture operation.

**Figure 29-1. Capture Mode Operation Block Diagram**



### 29.2.1 Capture Sources

In Capture mode, the CCPx pin should be configured as an input by setting the associated TRIS control bit.



**Important:** If the CCPx pin is configured as an output, a write to the port can cause a capture condition.

The capture source is selected by configuring the [CTS](#) bits as shown in the following table:

**Table 29-2. Capture Trigger Sources**

CTS	Source
111	CLC4_out
110	CLC3_out
101	CLC2_out
100	CLC1_out
011	IOC_interrupt
010	C2_out
001	C1_out
000	Pin selected by CCPxPPS

### 29.2.2 Timer1 Mode Resource

Timer1 must be running in Timer mode or Synchronized Counter mode for the CCP module to use the capture feature. In Asynchronous Counter mode, the capture operation may not work.

See section *"Timer1 Module with Gate Control"* for more information on configuring Timer1.

#### Related Links

[26. Timer1 Module with Gate Control](#)

### 29.2.3 Software Interrupt Mode

When the Capture mode is changed, a false capture interrupt may be generated. The user should keep the CCPxIE Interrupt Priority bit of the PIRx register clear to avoid false interrupts. Additionally, the user should clear the CCPxIF interrupt flag bit of the PIRx register following any change in Operating mode.



**Important:** Clocking Timer1 from the system clock ( $F_{OSC}$ ) should not be used in Capture mode. In order for Capture mode to recognize the trigger event on the CCPx pin, Timer1 must be clocked from the instruction clock ( $F_{OSC}/4$ ) or from an external clock source.

### 29.2.4 CCP Prescaler

There are four prescaler settings specified by the [MODE](#) bits. Whenever the CCP module is turned off, or the CCP module is not in Capture mode, the prescaler counter is cleared. Any Reset will clear the prescaler counter.

Switching from one capture prescaler to another does not clear the prescaler and may generate a false interrupt. To avoid this unexpected operation, turn the module off by clearing the CCPxCON register before changing the prescaler. The example below demonstrates the code to perform this function.

**Example 29-1. Changing Between Capture Prescalers**

```
BANKSEL CCP1CON      ; (only needed when CCP1CON is not in ACCESS space)
CLRF    CCP1CON      ; Turn CCP module off
MOVLW   NEW_CAPT_PS  ; CCP ON and Prescaler select → W
MOVWF   CCP1CON      ; Load CCP1CON with this value
```

### 29.2.5 Capture During Sleep

Capture mode depends upon the Timer1 module for proper operation. There are two options for driving the Timer1 module in Capture mode. It can be driven by the instruction clock ( $F_{OSC}/4$ ), or by an external clock source.

When Timer1 is clocked by  $F_{OSC}/4$ , Timer1 will not increment during Sleep. When the device wakes from Sleep, Timer1 will continue from its previous state.

Capture mode will operate during Sleep when Timer1 is clocked by an external clock source.

### 29.3 Compare Mode

The Compare mode function described in this section is available and identical for all CCP modules.

Compare mode makes use of the 16-bit odd numbered Timer resources (Timer1, Timer3, etc.). The 16-bit value of the CCPx register is constantly compared against the 16-bit value of the TMRx register. When a match occurs, one of the following events can occur:

- Toggle the CCPx output and clear TMRx
- Toggle the CCPx output without clearing TMRx
- Set the CCPx output
- Clear the CCPx output
- Pulse output
- Pulse output and clear TMRx

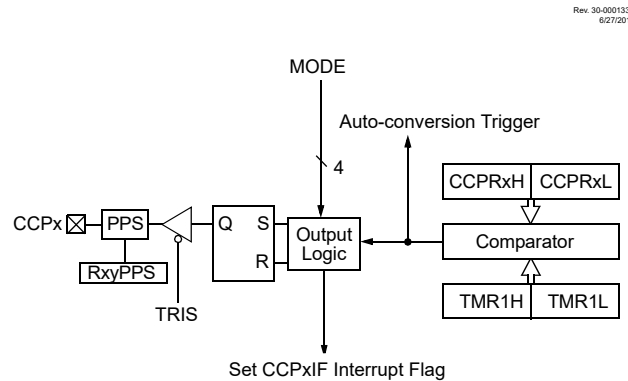
The action on the pin is based on the value of the **MODE** control bits. At the same time, the interrupt flag CCPxIF bit is set, and an ADC conversion can be triggered, if selected.

All Compare modes can generate an interrupt and trigger an ADC conversion. When **MODE** = '0001' or '1011', the CCP resets the TMRx register.

The following figure shows a simplified diagram of the compare operation.



Figure 29-2. Compare Mode Operation Block Diagram



### 29.3.1 CCPx Pin Configuration

The software must configure the CCPx pin as an output by clearing the associated TRIS bit and defining the appropriate output pin through the RxyPPS registers. See section "Peripheral Pin Select (PPS) Module" for more details.

The CCP output can also be used as an input for other peripherals.



**Important:** Clearing the CCPxCON register will force the CCPx compare output latch to the default low level. This is not the PORT I/O data latch.

#### Related Links

[15. \(PPS\) Peripheral Pin Select Module](#)

### 29.3.2 Timer1 Mode Resource

In Compare mode, Timer1 must be running in either Timer mode or Synchronized Counter mode. The compare operation may not work in Asynchronous Counter mode.

See Section "Timer1 Module with Gate Control" for more information on configuring Timer1.



**Important:** Clocking Timer1 from the system clock ( $F_{OSC}$ ) should not be used in Compare mode. In order for Compare mode to recognize the trigger event on the CCPx pin, Timer1 must be clocked from the instruction clock ( $F_{OSC}/4$ ) or from an external clock source.

### 29.3.3 Auto-Conversion Trigger

All CCPx modes set the CCP Interrupt Flag (CCPxIF). When this flag is set and a match occurs, an auto-conversion trigger can take place if the CCP module is selected as the conversion trigger source.

Refer to Section "Auto-Conversion Trigger" for more information.



**Important:** Removing the match condition by changing the contents of the CCPRxH and CCPRxL register pair, between the clock edge that generates the Auto-conversion Trigger and the clock edge that generates the Timer1 Reset, will preclude the Reset from occurring.

**Related Links**

[20.2.6 Auto-Conversion Trigger](#)

**29.3.4 Compare During Sleep**

Since  $F_{OSC}$  is shut down during Sleep mode, the Compare mode will not function properly during Sleep, unless the timer is running. The device will wake on interrupt (if enabled).

**29.4 PWM Overview**

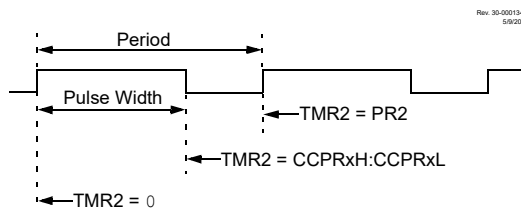
Pulse-Width Modulation (PWM) is a scheme that provides power to a load by switching quickly between fully ON and fully OFF states. The PWM signal resembles a square wave where the high portion of the signal is considered the ON state and the low portion of the signal is considered the OFF state. The high portion, also known as the pulse width, can vary in time and is defined in steps. A larger number of steps applied, which lengthens the pulse width, also supplies more power to the load. Lowering the number of steps applied, which shortens the pulse width, supplies less power. The PWM period is defined as the duration of one complete cycle or the total amount of ON and OFF time combined.

PWM resolution defines the maximum number of steps that can be present in a single PWM period. A higher resolution allows for more precise control of the pulse-width time and in turn the power that is applied to the load.

The term duty cycle describes the proportion of the ON time to the OFF time and is expressed in percentages, where 0% is fully OFF and 100% is fully ON. A lower duty cycle corresponds to less power applied and a higher duty cycle corresponds to more power applied.

The shows a typical waveform of the PWM signal.

**Figure 29-3. CCP PWM Output Signal**



**29.4.1 Standard PWM Operation**

The standard PWM function described in this section is available and identical for all CCP modules.

The standard PWM mode generates a Pulse-Width Modulation (PWM) signal on the CCPx pin with up to ten bits of resolution. The period, duty cycle, and resolution are controlled by the following registers:

- Even numbered TxPR registers (T2PR, T4PR, etc)
- Even numbered TxCON registers (T2CON, T4CON, etc)
- 16-bit CCPRx registers
- CCPxCON registers

It is required to have  $F_{OSC}/4$  as the clock input to TxTMR for correct PWM operation. The following figure shows a simplified block diagram of PWM operation.

Figure 29-4. Simplified PWM Block Diagram



**Note:**

1. 8-bit timer is concatenated with two bits generated by  $F_{OSC}$  or two bits of the internal prescaler to create 10-bit time base.
2. The alignment of the 10 bits from the CCPRx register is determined by the CCPxFMT bit.



**Important:** The corresponding TRIS bit must be cleared to enable the PWM output on the CCPx pin.

**29.4.2 Setup for PWM Operation**

The following steps should be taken when configuring the CCP module for standard PWM operation:

1. Use the desired output pin RxyPPS control to select CCPx as the source and disable the CCPx pin output driver by setting the associated TRIS bit.
2. Load the T2PR register with the PWM period value.
3. Configure the CCP module for the PWM mode by loading the CCPxCON register with the appropriate values.
4. Load the CCPRx register with the PWM duty cycle value and configure the FMT bit to set the proper register alignment.
5. Configure and start Timer2:
  - Clear the TMR2IF interrupt flag bit of the PIRx register. See Note below.
  - Select the timer clock source to be as  $F_{OSC}/4$  using the TxCLKCON register. This is required for correct operation of the PWM module.
  - Configure the T2CKPS bits of the T2CON register with the timer prescale value.
  - Enable the timer by setting the T2ON bit.

6. Enable PWM output pin:
  - Wait until the timer overflows and the TMR2IF bit of the PIRx register is set. See Note below.
  - Enable the CCPx pin output driver by clearing the associated TRIS bit.



**Important:** In order to send a complete duty cycle and period on the first PWM output, the above steps must be included in the setup sequence. If it is not critical to start with a complete PWM signal on the first output, then step 6 may be ignored.

#### Related Links

[27.9.3 TxCON](#)

#### 29.4.3 Timer2 Timer Resource

The PWM standard mode makes use of the 8-bit Timer2 timer resources to specify the PWM period.

#### 29.4.4 PWM Period

The PWM period is specified by the T2PR register of Timer2. The PWM period can be calculated using the formula in the equation below.

##### Equation 29-1. PWM Period

$$PWMPeriod = [(T2PR + 1)] \cdot 4 \cdot T_{OSC} \cdot (TMR2PrescaleValue)$$

where  $T_{OSC} = 1/F_{OSC}$

When T2TMR is equal to T2PR, the following three events occur on the next increment cycle:

- T2TMR is cleared
- The CCPx pin is set. (Exception: If the PWM duty cycle = 0%, the pin will not be set.)
- The PWM duty cycle is transferred from the CCPRx register into a 10-bit buffer.



**Important:** The Timer postscaler (see "*Timer2 Interrupt*") is not used in the determination of the PWM frequency.

#### Related Links

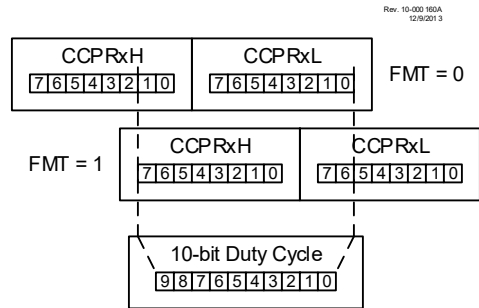
[27.4 Timer2 Interrupt](#)

#### 29.4.5 PWM Duty Cycle

The PWM duty cycle is specified by writing a 10-bit value to the CCPRx register. The alignment of the 10-bit value is determined by the FMT bit (see [Figure 29-5](#)). The CCPRx register can be written to at any time. However, the duty cycle value is not latched into the 10-bit buffer until after a match between T2PR and T2TMR.

The equations below are used to calculate the PWM pulse width and the PWM duty cycle ratio.

Figure 29-5. PWM 10-Bit Alignment



**Equation 29-2. Pulse Width**

$$Pulse\ Width = (CCPRxH:CCPRxL\ register\ value) \cdot T_{OSC} \cdot (TMR2\ Prescale\ Value)$$

**Equation 29-3. Duty Cycle**

$$DutyCycleRatio = \frac{(CCPRxH:CCPRxL\ register\ value)}{4(T2PR + 1)}$$

The CCPRx register is used to double buffer the PWM duty cycle. This double buffering is essential for glitchless PWM operation.

The 8-bit timer T2TMR register is concatenated with either the 2-bit internal system clock (F<sub>OSC</sub>), or two bits of the prescaler, to create the 10-bit time base. The system clock is used if the Timer2 prescaler is set to 1:1.

When the 10-bit time base matches the CCPRx register, then the CCPx pin is cleared (see Figure 29-4).

**29.4.6 PWM Resolution**

The resolution determines the number of available duty cycles for a given period. For example, a 10-bit resolution will result in 1024 discrete duty cycles, whereas an 8-bit resolution will result in 256 discrete duty cycles.

The maximum PWM resolution is ten bits when T2PR is 255. The resolution is a function of the T2PR register value as shown below.

**Equation 29-4. PWM Resolution**

$$Resolution = \frac{\log[4(T2PR + 1)]}{\log(2)}\ bits$$



**Important:** If the pulse-width value is greater than the period, the assigned PWM pin(s) will remain unchanged.

Table 29-3. Example PWM Frequencies and Resolutions (F<sub>OSC</sub> = 20 MHz)

PWM Frequency	1.22 kHz	4.88 kHz	19.53 kHz	78.12 kHz	156.3 kHz	208.3 kHz
Timer Prescale	16	4	1	1	1	1
T2PR Value	0xFF	0xFF	0xFF	0x3F	0x1F	0x17
Maximum Resolution (bits)	10	10	10	8	7	6.6

**Table 29-4. Example PWM Frequencies and Resolutions ( $F_{OSC} = 8 \text{ MHz}$ )**

PWM Frequency	1.22 kHz	4.90 kHz	19.61 kHz	76.92 kHz	153.85 kHz	200.0 kHz
Timer Prescale	16	4	1	1	1	1
T2PR Value	0x65	0x65	0x65	0x19	0x0C	0x09
Maximum Resolution (bits)	8	8	8	6	5	5

#### 29.4.7 Operation in Sleep Mode

In Sleep mode, the T2TMR register will not increment and the state of the module will not change. If the CCPx pin is driving a value, it will continue to drive that value. When the device wakes up, T2TMR will continue from the previous state.

#### 29.4.8 Changes in System Clock Frequency

The PWM frequency is derived from the system clock frequency. Any changes in the system clock frequency will result in changes to the PWM frequency. See the "*Oscillator Module (with Fail-Safe Clock Monitor)*" section for additional details.

##### Related Links

[9. Oscillator Module \(with Fail-Safe Clock Monitor\)](#)

#### 29.4.9 Effects of Reset

Any Reset will force all ports to Input mode and the CCP registers to their Reset states.

## 29.5 Register Summary - CCP Control

Address	Name	Bit Pos.						
0x030C	CCPR1	7:0	CCPRL[7:0]					
		15:8	CCPRH[7:0]					
0x030E	CCP1CON	7:0	EN		OUT	FMT	MODE[3:0]	
0x030F	CCP1CAP	7:0					CTS[2:0]	
0x0310	CCPR2	7:0	CCPRL[7:0]					
		15:8	CCPRH[7:0]					
0x0312	CCP2CON	7:0	EN		OUT	FMT	MODE[3:0]	
0x0313	CCP2CAP	7:0					CTS[2:0]	
0x0314	CCPR3	7:0	CCPRL[7:0]					
		15:8	CCPRH[7:0]					
0x0316	CCP3CON	7:0	EN		OUT	FMT	MODE[3:0]	
0x0317	CCP3CAP	7:0					CTS[2:0]	
0x0318	CCPR4	7:0	CCPRL[7:0]					
		15:8	CCPRH[7:0]					
0x031A	CCP4CON	7:0	EN		OUT	FMT	MODE[3:0]	
0x031B	CCP4CAP	7:0					CTS[2:0]	
0x031C	CCPR5	7:0	CCPRL[7:0]					
		15:8	CCPRH[7:0]					
0x031E	CCP5CON	7:0	EN		OUT	FMT	MODE[3:0]	
0x031F	CCP5CAP	7:0					CTS[2:0]	

## 29.6 Register Definitions: CCP Control

Long bit name prefixes for the CCP peripherals are shown in the following table. Refer to the “*Long Bit Names*” section for more information.

**Table 29-5. CCP Long bit name prefixes**

Peripheral	Bit Name Prefix
CCP1	CCP1
CCP2	CCP2
CCP3	CCP3
CCP4	CCP4
CCP5	CCP5

### Related Links

[1.4.2.2 Long Bit Names](#)

### 29.6.1 CCPxCON

**Name:** CCPxCON  
**Address:** 0x30E,0x312,0x316,0x31A,0x31E

CCP Control Register

Bit	7	6	5	4	3	2	1	0
	EN		OUT	FMT	MODE[3:0]			
Access	R/W		RO	R/W	R/W	R/W	R/W	R/W
Reset	0		x	0	0	0	0	0

**Bit 7 – EN** CCP Module Enable bit

Value	Description
1	CCP is enabled
0	CCP is disabled

**Bit 5 – OUT** CCP Output Data bit (read-only)

**Bit 4 – FMT** CCPW (pulse-width) Value Alignment bit

Value	Condition	Description
x	Capture mode	Not used
x	Compare mode	Not used
1	PWM mode	Left-aligned format
0	PWM mode	Right-aligned format

**Bits 3:0 – MODE[3:0]** CCP Mode Select bits

**Table 29-6. CCPx Mode Select Bits**

MODE	Operating Mode	Operation	Set CCPxIF
11xx	PWM	PWM Operation	Yes
1011	Compare	Pulse output; clear TMR1 <sup>(2)</sup>	Yes
1010		Pulse output	Yes
1001		Clear output <sup>(1)</sup>	Yes
1000		Set output <sup>(1)</sup>	Yes
0111	Capture	Every 16 <sup>th</sup> rising edge of CCPx input	Yes
0110		Every 4 <sup>th</sup> rising edge of CCPx input	Yes
0101		Every rising edge of CCPx input	Yes
0100		Every falling edge of CCPx input	Yes
0011		Every edge of CCPx input	Yes
0010	Compare	Toggle output	Yes



# PIC16(L)F18455/56

## Capture/Compare/PWM Module

MODE	Operating Mode	Operation	Set CCPxIF
0001		Toggle output; clear TMR1 <sup>(2)</sup>	Yes
0000	Disabled		—

**Note:**

1. The set and clear operations of the Compare mode are reset by setting MODE = '0000' or EN = 0.
2. When MODE = '0001' or '1011', then the timer associated with the CCP module is cleared. TMR1 is the default selection for the CCP module, so it is used for indication purpose only.

**Note:**

1. The set and clear operations of the Compare mode are reset by setting MODE = '0000' or EN = 0.
2. When MODE = '0001' or '1011', then the timer associated with the CCP module is cleared. TMR1 is the default selection for the CCP module, so it is used for indication purpose only.

**29.6.2 CCPxCAP**

**Name:** CCPxCAP  
**Address:** 0x30F,0x313,0x317,0x31B,0x31F

Capture Trigger Input Selection Register

Bit	7	6	5	4	3	2	1	0
	CTS[2:0]							
Access						R/W	R/W	R/W
Reset						0	0	0

**Bits 2:0 – CTS[2:0]** Capture Trigger Input Selection bits

**Table 29-7. Capture Trigger Sources**

CTS	Source
111	CLC4_out
110	CLC3_out
101	CLC2_out
100	CLC1_out
011	IOC_interrupt
010	C2_out
001	C1_out
000	Pin selected by CCPxPPS

**29.6.3 CCPRx**

**Name:** CCPRx  
**Address:** 0x30C,0x310,0x314,0x318,0x31C

Capture/Compare/Pulse Width Register

Bit	15	14	13	12	11	10	9	8
	CCPRH[7:0]							
Access	R/W	R/W	R/W	R/W	R/W	R/W	R/W	R/W
Reset	x	x	x	x	x	x	x	x
Bit	7	6	5	4	3	2	1	0
	CCPRL[7:0]							
Access	R/W	R/W	R/W	R/W	R/W	R/W	R/W	R/W
Reset	x	x	x	x	x	x	x	x

**Bits 15:8 – CCPRH[7:0]**

Capture/Compare/Pulse Width High byte

Value	Name	Description
0 to 255	<b>MODE</b> = Capture	High byte of 16-bit captured value
0 to 255	<b>MODE</b> = Compare	High byte of 16-bit compare value
0, 1, 2, 3	<b>MODE</b> = PWM & <b>FMT</b> =0	CCPRH<1:0>=Bits<9:8> of 10-bit Pulse width value CCPRH<7:2> not used
0 to 255	<b>MODE</b> = PWM & <b>FMT</b> =1	Bits<9:2> of 10-bit Pulse width value

**Bits 7:0 – CCPRL[7:0]**

Capture/Compare/Pulse Width Low byte

Value	Name	Description
0 to 255	<b>MODE</b> = Capture	Low byte of 16-bit captured value
0 to 255	<b>MODE</b> = Compare	Low byte of 16-bit compare value
0 to 255	<b>MODE</b> = PWM & <b>FMT</b> =0	Bits<7:0> of 10-bit Pulse width value
0, 64, 128, 192	<b>MODE</b> = PWM & <b>FMT</b> =1	CCPRL<7:6>=Bits<1:0> of 10-bit Pulse width value CCPRL<5:0> not used

### 30. (PWM) Pulse-Width Modulation

The PWM module generates a Pulse-Width Modulated signal determined by the duty cycle, period, and resolution that are configured by the following registers:

- TxPR
- TxCON
- PWMxDC
- PWMxCON



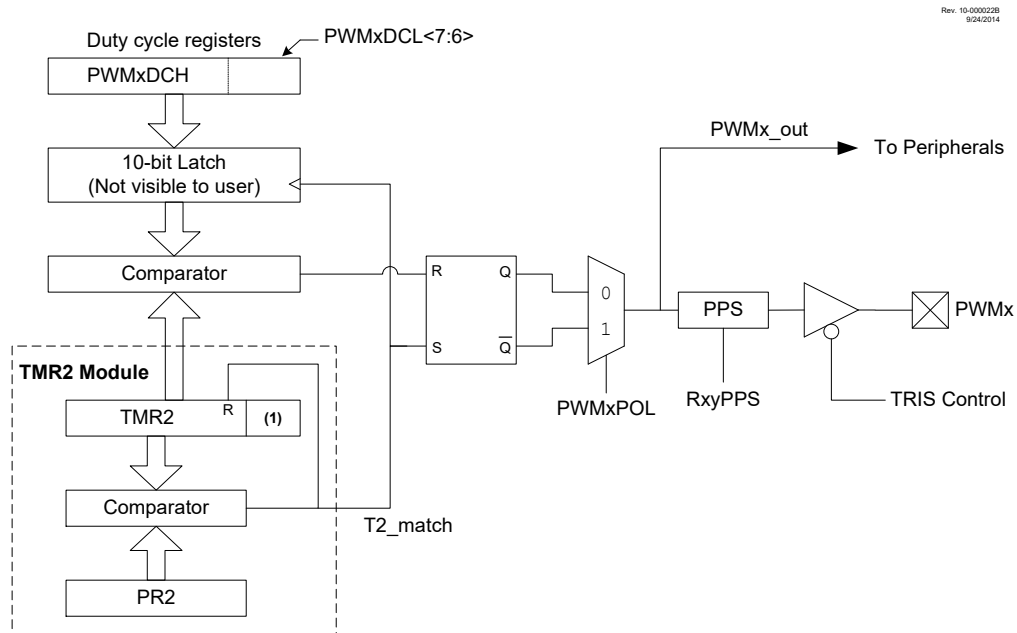
**Important:** The corresponding TRIS bit must be cleared to enable the PWM output on the PWMx pin.

Each PWM module can select the timer source that controls the module. Note that the PWM mode operation is described with respect to TMR2 in the following sections.

Figure 30-1 shows a simplified block diagram of PWM operation.

Figure 30-2 shows a typical waveform of the PWM signal.

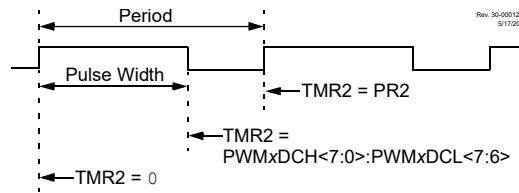
**Figure 30-1. Simplified PWM Block Diagram**



**Note:**

1. 8-bit timer is concatenated with two bits generated by Fosc or two bits of the internal prescaler to create 10-bit time base.

Figure 30-2. PWM Output



For a step-by-step procedure on how to set up this module for PWM operation, refer to [30.9 Setup for PWM Operation using PWMx Output Pins](#).

### 30.1 Fundamental Operation

The PWM module produces a 10-bit resolution output. The PWM timer can be selected using the PxTSEL bits in the CCPTMRS register. The default selection for PWMx is TMR2. Note that the PWM module operation in the following sections is described with respect to TMR2. Timer2 and T2PR set the period of the PWM. The PWMxDCL and PWMxDCH registers configure the duty cycle. The period is common to all PWM modules, whereas the duty cycle is independently controlled.



**Important:** The Timer2 postscaler is not used in the determination of the PWM frequency. The postscaler could be used to have a servo update rate at a different frequency than the PWM output.

All PWM outputs associated with Timer2 are set when T2TMR is cleared. Each PWMx is cleared when TxTMR is equal to the value specified in the corresponding PWMxDCH (8 MSb) and PWMxDCL<7:6> (2 LSb) registers. When the value is greater than or equal to T2PR, the PWM output is never cleared (100% duty cycle).



**Important:** The PWMxDCH and PWMxDCL registers are double buffered. The buffers are updated when T2TMR matches T2PR. Care should be taken to update both registers before the timer match occurs.

### 30.2 PWM Output Polarity

The output polarity is inverted by setting the POL bit.

### 30.3 PWM Period

The PWM period is specified by the TxPR register. The PWM period can be calculated using the formula of [30.3 PWM Period](#). It is required to have  $F_{OSC}/4$  as the selected clock input to the timer for correct PWM operation.

#### Equation 30-1. PWM Period

$$PWMPeriod = [(T2PR) + 1] \cdot 4 \cdot T_{osc} \cdot (TMR2 \text{ PrescaleValue})$$

**Note:**  $T_{OSC} = 1/F_{OSC}$

When T2TMR is equal to T2PR, the following three events occur on the next increment cycle:

- T2TMR is cleared
- The PWM output is active. (Exception: When the PWM duty cycle = 0%, the PWM output will remain inactive.)
- The PWMxDCH and PWMxDCL register values are latched into the buffers.



**Important:** The Timer2 postscaler has no effect on the PWM operation.

### 30.4 PWM Duty Cycle

The PWM duty cycle is specified by writing a 10-bit value to the PWMxDCH and PWMxDCL register pair. The PWMxDCH register contains the eight MSBs and the PWMxDCL<7:6>, the two LSBs. The PWMxDCH and PWMxDCL registers can be written to at any time.

The formulas below are used to calculate the PWM pulse width and the PWM duty cycle ratio.

#### Equation 30-2. Pulse Width

$$PulseWidth = (PWMxDCH:PWMxDCL < 7:6 >) \cdot T_{osc} \cdot (TMR2PrescaleValue)$$

**Note:**  $T_{OSC} = 1/F_{OSC}$

#### Equation 30-3. Duty Cycle Ratio

$$DutyCycleRatio = \frac{(PWMxDCH:PWMxDCL < 7:6 >)}{4(T2PR + 1)}$$

The 8-bit timer T2TMR register is concatenated with the two Least Significant bits of  $1/F_{OSC}$ , adjusted by the Timer2 prescaler to create the 10-bit time base. The system clock is used if the Timer2 prescaler is set to 1:1.

### 30.5 PWM Resolution

The resolution determines the number of available duty cycles for a given period. For example, a 10-bit resolution will result in 1024 discrete duty cycles, whereas an 8-bit resolution will result in 256 discrete duty cycles.

The maximum PWM resolution is ten bits when T2PR is 255. The resolution is a function of the T2PR register value as shown below.

#### Equation 30-4. PWM Resolution

$$Resolution = \frac{\log[4(T2PR + 1)]}{\log(2)} \text{ bits}$$



**Important:** If the pulse-width value is greater than the period, the assigned PWM pin(s) will remain unchanged.

**Table 30-1. Example PWM Frequencies and Resolutions (Fosc = 20 MHz)**

PWM Frequency	0.31 kHz	4.88 kHz	19.53 kHz	78.12 kHz	156.3 kHz	208.3 kHz
Timer Prescale	64	4	1	1	1	1
T2PR Value	0xFF	0xFF	0xFF	0x3F	0x1F	0x17
Maximum Resolution (bits)	10	10	10	8	7	6.6

**Table 30-2. Example PWM Frequencies and Resolutions (Fosc = 8 MHz)**

PWM Frequency	0.31 kHz	4.90 kHz	19.61 kHz	76.92 kHz	153.85 kHz	200.0 kHz
Timer Prescale	64	4	1	1	1	1
T2PR Value	0x65	0x65	0x65	0x19	0x0C	0x09
Maximum Resolution (bits)	8	8	8	6	5	5

### 30.6 Operation in Sleep Mode

In Sleep mode, the T2TMR register will not increment and the state of the module will not change. If the PWMx pin is driving a value, it will continue to drive that value. When the device wakes up, T2TMR will continue from its previous state.

### 30.7 Changes in System Clock Frequency

The PWM frequency is derived from the system clock frequency ( $F_{OSC}$ ). Any changes in the system clock frequency will result in changes to the PWM frequency.

#### Related Links

[9. Oscillator Module \(with Fail-Safe Clock Monitor\)](#)

### 30.8 Effects of Reset

Any Reset will force all ports to Input mode and the PWM registers to their Reset states.

### 30.9 Setup for PWM Operation using PWMx Output Pins

The following steps should be taken when configuring the module for PWM operation using the PWMx pins:

1. Disable the PWMx pin output driver(s) by setting the associated TRIS bit(s).
2. Clear the PWMxCON register.
3. Load the T2PR register with the PWM period value.
4. Load the PWMxDCH register and bits <7:6> of the PWMxDCL register with the PWM duty cycle value.
5. Configure and start Timer2:
  - Clear the TMR2IF interrupt flag bit of the PIRx register.<sup>(1)</sup>
  - Select the timer clock source to be as  $F_{OSC}/4$  using the TxCLKCON register. This is required for correct operation of the PWM module.

- Configure the T2CKPS bits of the T2CON register with the Timer2 prescale value.
  - Enable Timer2 by setting the T2ON bit of the T2CON register.
6. Enable PWM output pin and wait until Timer2 overflows, TMR2IF bit of the PIRx register is set.<sup>(2)</sup>
  7. Enable the PWMx pin output driver(s) by clearing the associated TRIS bit(s) and setting the desired pin PPS control bits.
  8. Configure the PWM module by loading the PWMxCON register with the appropriate values.

**Note:**

1. In order to send a complete duty cycle and period on the first PWM output, the above steps must be followed in the order given. If it is not critical to start with a complete PWM signal, then move Step 8 to replace Step 4.
2. For operation with other peripherals only, disable PWMx pin outputs.

### 30.9.1 PWMx Pin Configuration

All PWM outputs are multiplexed with the PORT data latch. The user must configure the pins as outputs by clearing the associated TRIS bits.

### 30.10 Setup for PWM Operation to Other Device Peripherals

The following steps should be taken when configuring the module for PWM operation to be used by other device peripherals:

1. Disable the PWMx pin output driver(s) by setting the associated TRIS bit(s).
2. Clear the PWMxCON register.
3. Load the T2PR register with the PWM period value.
4. Load the PWMxDCH register and bits <7:6> of the PWMxDCL register with the PWM duty cycle value.
5. Configure and start Timer2:
  - Clear the TMR2IF interrupt flag bit of the PIRx register.<sup>(1)</sup>
  - Select the timer clock source to be as  $F_{OSC}/4$  using the TxCLKCON register. This is required for correct operation of the PWM module.
  - Configure the T2CKPS bits of the T2CON register with the Timer2 prescale value.
  - Enable Timer2 by setting the T2ON bit of the T2CON register.
6. Wait until Timer2 overflows, TMR2IF bit of the PIRx register is set.<sup>(1)</sup>
7. Configure the PWM module by loading the PWMxCON register with the appropriate values.

**Note:**

1. In order to send a complete duty cycle and period on the first PWM output, the above steps must be included in the setup sequence. If it is not critical to start with a complete PWM signal on the first output, then step 6 may be ignored.



### 30.11 Register Summary - Registers Associated with PWM

Address	Name	Bit Pos.							
0x038C	PWM6DC	7:0	DCL[1:0]						
		15:8	DCH[7:0]						
0x038E	PWM6CON	7:0	EN		OUT	POL			
0x038F	Reserved								
0x0390	PWM7DC	7:0	DCL[1:0]						
		15:8	DCH[7:0]						
0x0392	PWM7CON	7:0	EN		OUT	POL			

### 30.12 Register Definitions: PWM Control

Long bit name prefixes for the PWM peripherals are shown in the table below. Refer to the *"Long Bit Names Section"* for more information.

**Table 30-3. PWM Bit Name Prefixes**

Peripheral	Bit Name Prefix
PWM6	PWM6
PWM7	PWM7

#### Related Links

[1.4.2.2 Long Bit Names](#)

**30.12.1 PWMxCON**

**Name:** PWMxCON  
**Address:** 0x38E,0x392

PWM Control Register

Bit	7	6	5	4	3	2	1	0
	EN		OUT	POL				
Access	R/W		RO	R/W				
Reset	0		0	0				

**Bit 7 – EN** PWM Module Enable bit

Value	Description
1	PWM module is enabled
0	PWM module is disabled

**Bit 5 – OUT** PWM Module Output Level When Bit is Read

**Bit 4 – POL** PWM Output Polarity Select bit

Value	Description
1	PWM output is inverted
0	PWM output is normal

**30.12.2 PWMxDC**

**Name:** PWMxDC  
**Address:** 0x38C,0x390

PWM Duty Cycle Register

	Bit	15	14	13	12	11	10	9	8
		DCH[7:0]							
Access									
Reset		x	x	x	x	x	x	x	x
	Bit	7	6	5	4	3	2	1	0
		DCL[1:0]							
Access									
Reset		x	x						

**Bits 15:8 – DCH[7:0]** PWM Duty Cycle Most Significant bits  
 These bits are the MSBs of the PWM duty cycle.

Reset States: POR/BOR = xxxxxxxx  
 All Other Resets = uuuuuuuu

**Bits 7:6 – DCL[1:0]** PWM Duty Cycle Least Significant bits  
 These bits are the LSbs of the PWM duty cycle.

Reset States: POR/BOR = xx  
 All Other Resets = uu

## 31. (CWG) Complementary Waveform Generator Module

The Complementary Waveform Generator (CWG) produces half-bridge, full-bridge, and steering of PWM waveforms. It is backwards compatible with previous CCP functions. The PIC16(L)F18455/56 family has 3 instance(s) of the CWG module.

The CWG has the following features:

- Six Operating modes:
  - Synchronous Steering mode
  - Asynchronous Steering mode
  - Full-Bridge mode, Forward
  - Full-Bridge mode, Reverse
  - Half-Bridge mode
  - Push-Pull mode
- Output Polarity Control
- Output Steering
- Independent 6-Bit Rising and Falling Event Dead-Band Timers:
  - Clocked dead band
  - Independent rising and falling dead-band enables
- Auto-Shutdown Control With:
  - Selectable shutdown sources
  - Auto-restart option
  - Auto-shutdown pin override control

### 31.1 Fundamental Operation

The CWG generates two output waveforms from the selected input source.

The off-to-on transition of each output can be delayed from the on-to-off transition of the other output, thereby, creating a time delay immediately where neither output is driven. This is referred to as dead time and is covered in [31.7 Dead-Band Control](#).

It may be necessary to guard against the possibility of circuit faults or a feedback event arriving too late or not at all. In this case, the active drive must be terminated before the Fault condition causes damage. This is referred to as auto-shutdown and is covered in [31.11 Auto-Shutdown](#).

### 31.2 Operating Modes

The CWG module can operate in six different modes, as specified by the [MODE](#) bits:

- Half-Bridge mode
- Push-Pull mode
- Asynchronous Steering mode
- Synchronous Steering mode
- Full-Bridge mode, Forward
- Full-Bridge mode, Reverse

All modes accept a single pulse data input, and provide up to four outputs as described in the following sections.

All modes include auto-shutdown control as described in [31.11 Auto-Shutdown](#)



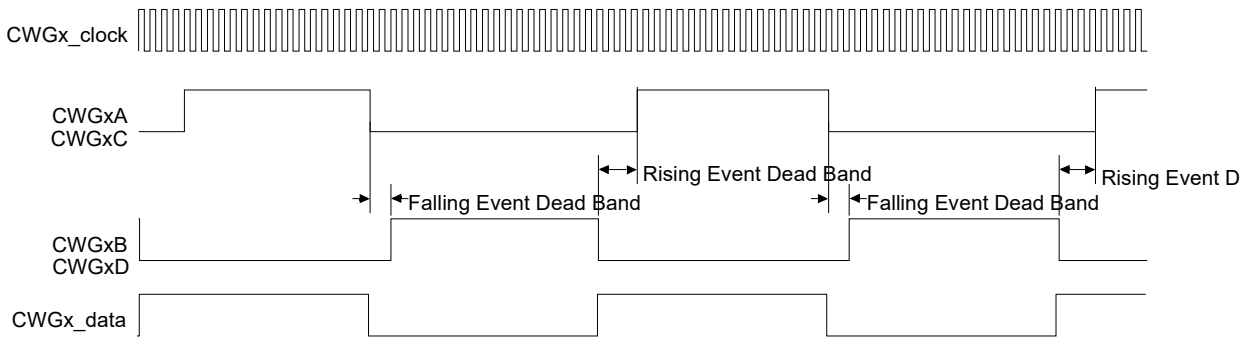
**Important:** Except as noted for Full-Bridge mode ([31.2.3 Full-Bridge Modes](#)), mode changes should only be performed while  $EN = 0$ .

### 31.2.1 Half-Bridge Mode

In Half-Bridge mode, two output signals are generated as true and inverted versions of the input as illustrated in [Figure 31-1](#). A non-overlap (dead-band) time is inserted between the two outputs to prevent shoot-through current in various power supply applications. Dead-band control is described in [31.7 Dead-Band Control](#). The output steering feature cannot be used in this mode. A basic block diagram of this mode is shown in [Figure 31-2](#).

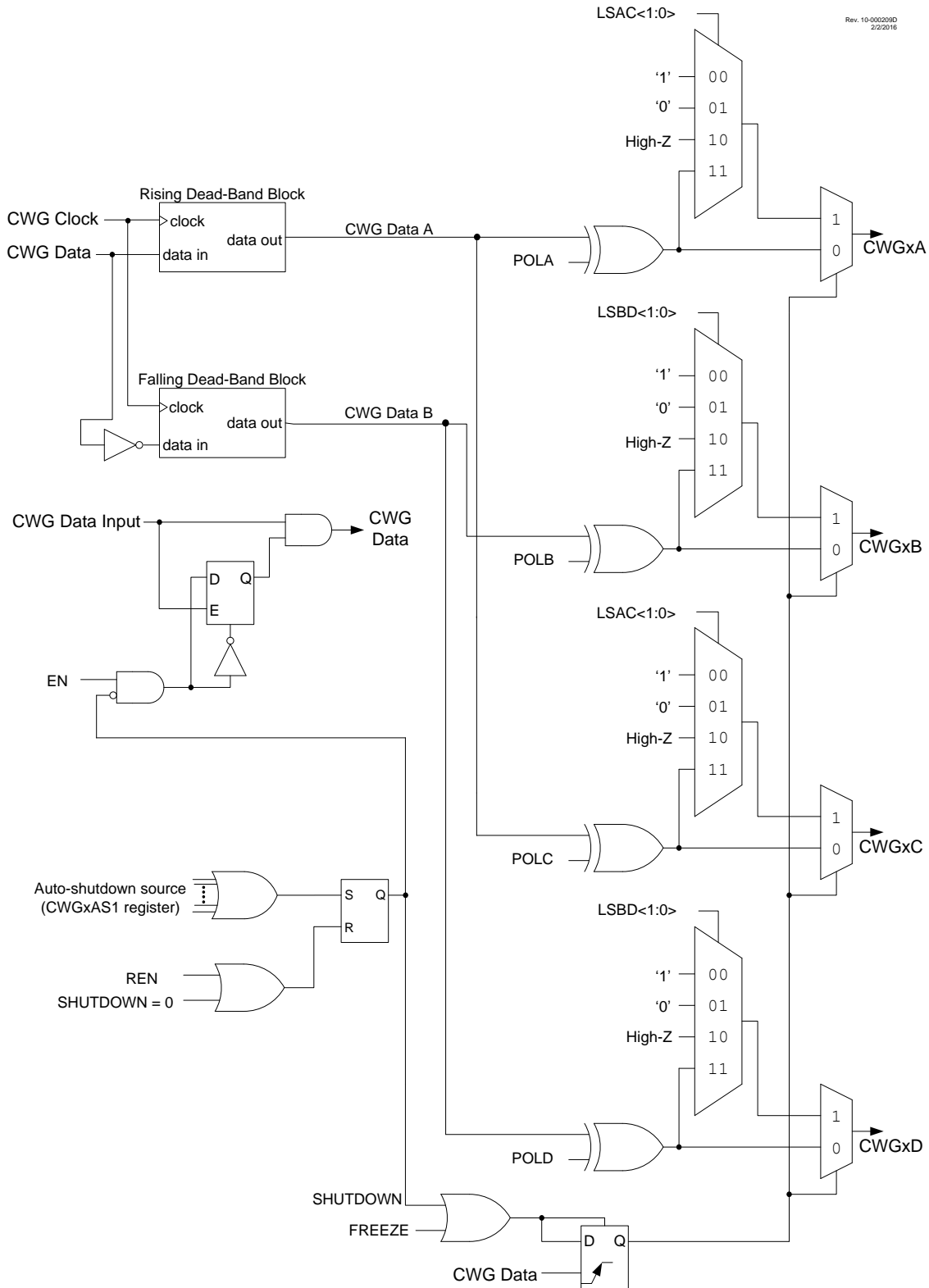
The unused outputs CWGxC and CWGxD drive similar signals, with polarity independently controlled by the [POLC](#) and [POLD](#) bits, respectively.

**Figure 31-1. CWG Half-Bridge Mode Operation**



**Note:** CWGx\_rising\_src = CCP1\_out, CWGx\_falling\_src = ~CCP1\_out

Figure 31-2. Simplified CWG Block Diagram (Half-Bridge Mode, MODE<2:0> = 100)



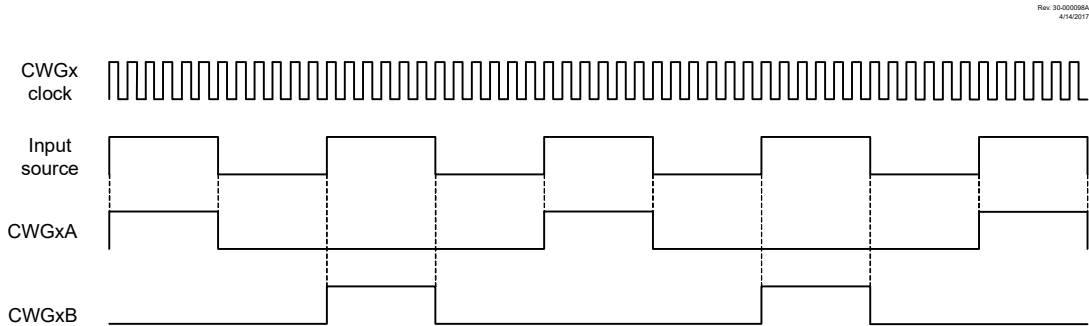
**31.2.2 Push-Pull Mode**

In Push-Pull mode, two output signals are generated, alternating copies of the input as illustrated in [Figure 31-3](#). This alternation creates the push-pull effect required for driving some transformer-based power supply designs. Steering modes are not used in Push-Pull mode. A basic block diagram for the Push-Pull mode is shown in [Figure 31-4](#).

The push-pull sequencer is reset whenever  $EN = 0$  or if an auto-shutdown event occurs. The sequencer is clocked by the first input pulse, and the first output appears on CWG1A.

The unused outputs CWGxC and CWGxD drive copies of CWGxA and CWGxB, respectively, but with polarity controlled by the POLC and POLD bits of the CWGxCON1 register, respectively.

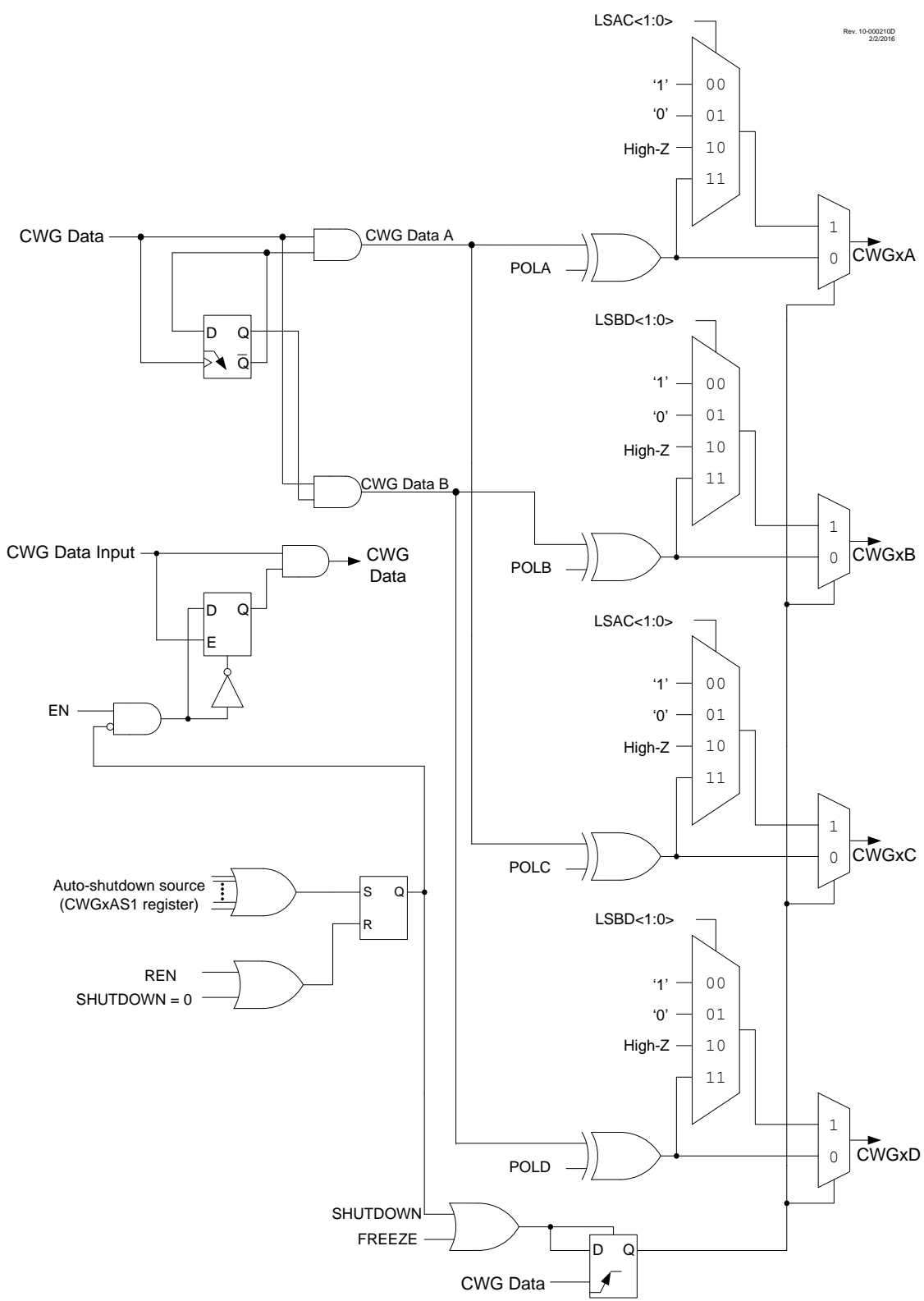
**Figure 31-3. CWG Push-Pull Mode Operation**



# PIC16(L)F18455/56

## (CWG) Complementary Waveform Generator Modul...

Figure 31-4. Simplified CWG Block Diagram (Push-Pull Mode, MODE<2:0> = 101)



Rev. 10-000210D  
2/2/2016



31.2.3 Full-Bridge Modes

In Forward and Reverse Full-Bridge modes, three outputs drive static values while the fourth is modulated by the input data signal. The mode selection may be toggled between forward and reverse by toggling the MODE<0> bit of the CWGxCON0 while keeping MODE<2:1> static, without disabling the CWG module. When connected, as shown in Figure 31-5, the outputs are appropriate for a full-bridge motor driver. Each CWG output signal has independent polarity control, so the circuit can be adapted to high-active and low-active drivers. A simplified block diagram for the Full-Bridge modes is shown in Figure 31-6.

Figure 31-5. Example of Full-Bridge Application

Rev. 10-00283A  
12/8/2015

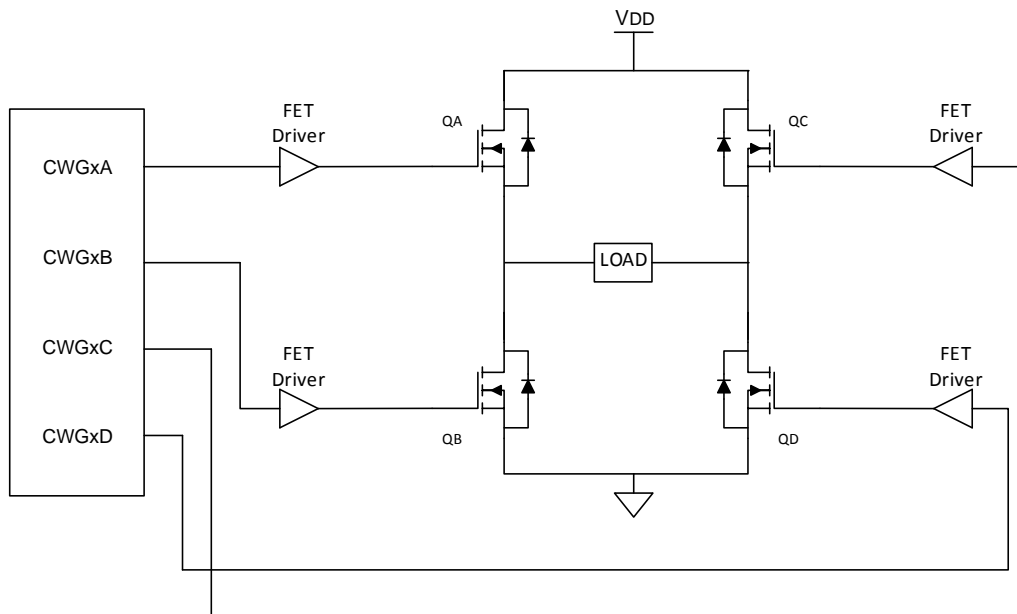
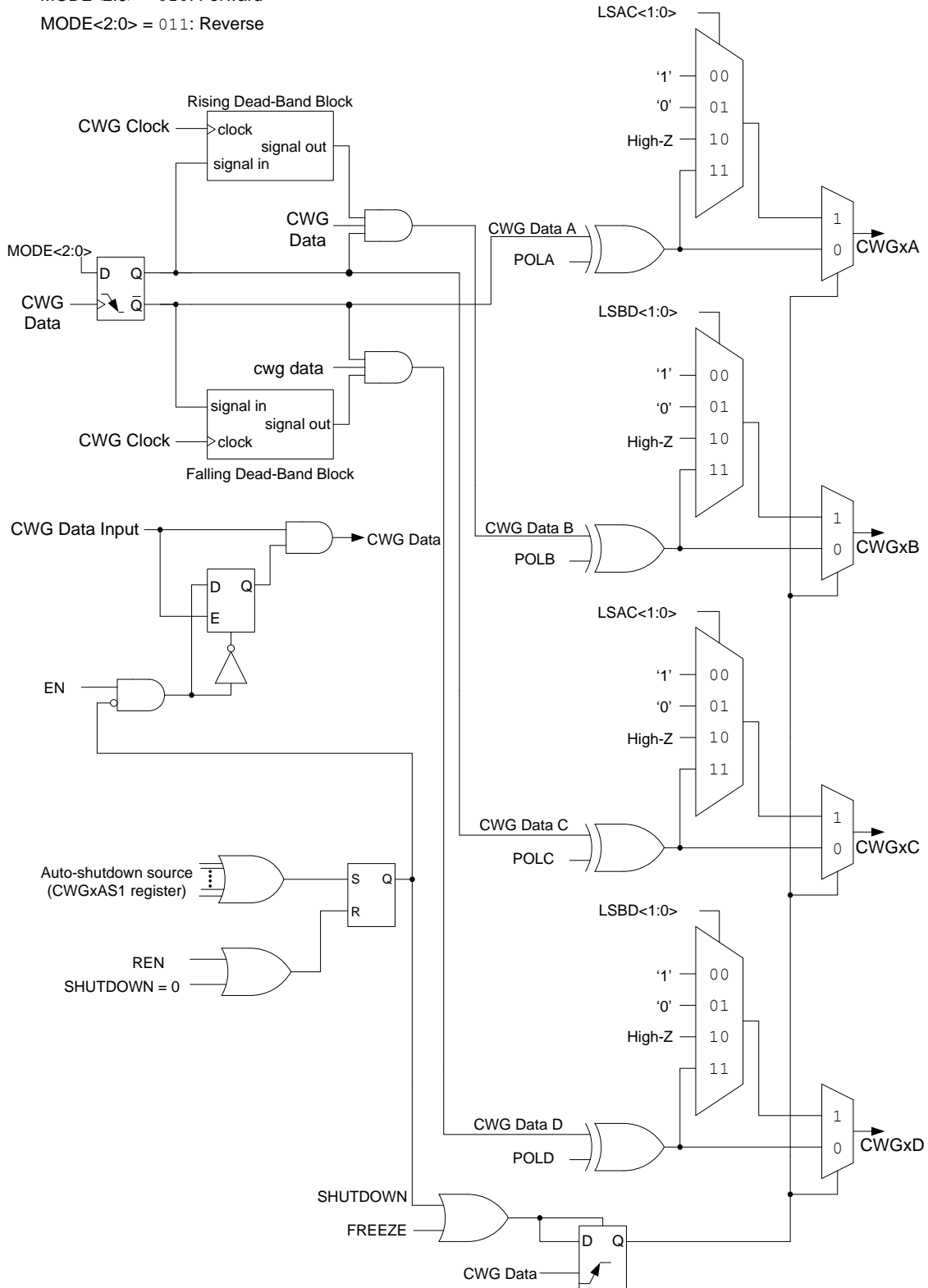


Figure 31-6. Simplified CWG Block Diagram (Forward and Reverse Full-Bridge Modes)

MODE<2:0> = 010: Forward  
 MODE<2:0> = 011: Reverse

Rev. 10-000212D  
 2/2/2016

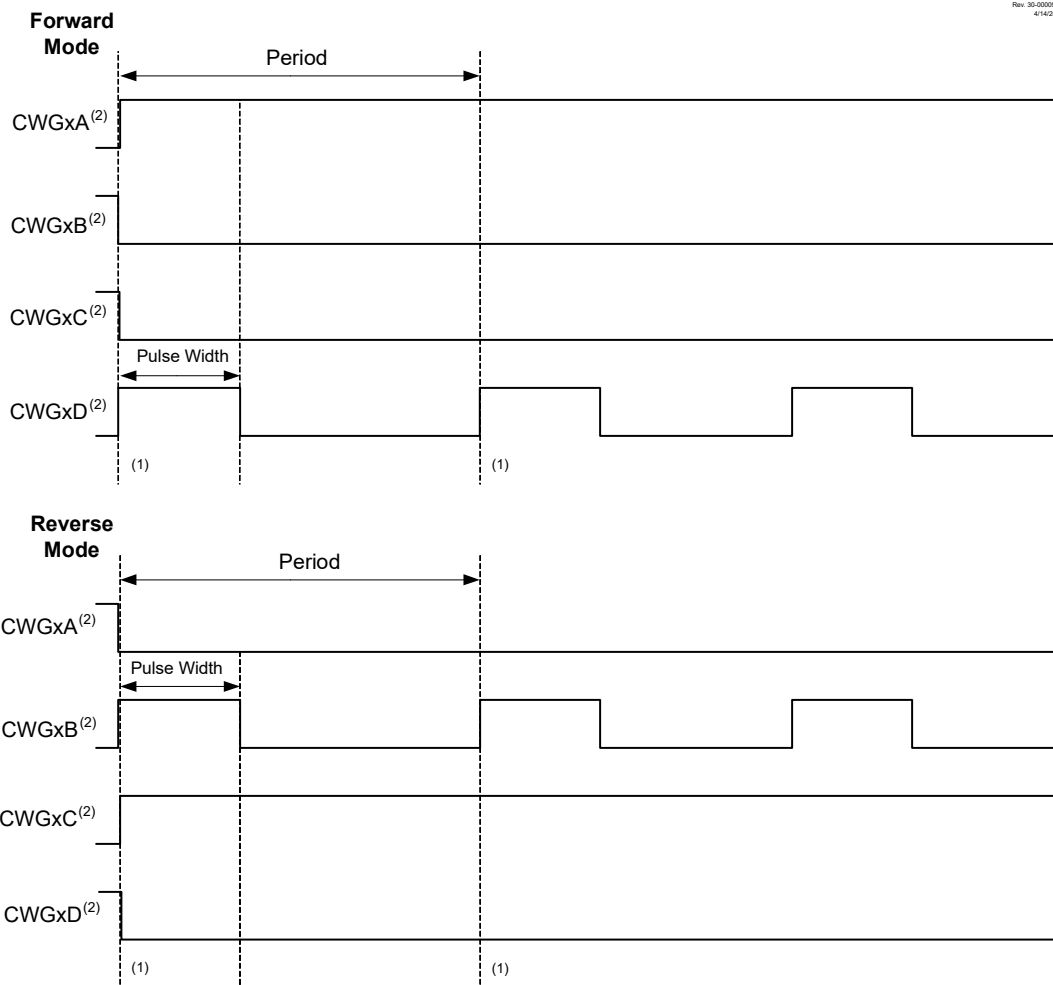


In Forward Full-Bridge mode ( $MODE = 010$ ), CWGxA is driven to its active state, CWGxB and CWGxC are driven to their inactive state, and CWGxD is modulated by the input signal, as shown in Figure 31-7.

In Reverse Full-Bridge mode ( $MODE = 011$ ), CWGxC is driven to its active state, CWGxA and CWGxD are driven to their inactive states, and CWGxB is modulated by the input signal, as shown in Figure 31-7.

In Full-Bridge mode, the dead-band period is used when there is a switch from forward to reverse or vice-versa. This dead-band control is described in 31.7 Dead-Band Control, with additional details in 31.8 Rising Edge and Reverse Dead Band and 31.9 Falling Edge and Forward Dead Band. Steering modes are not used with either of the Full-Bridge modes. The mode selection may be toggled between forward and reverse toggling the  $MODE<0>$  bit of the CWGxCON0 while keeping  $MODE<2:1>$  static, without disabling the CWG module.

Figure 31-7. Example of Full-Bridge Output



**Note:**

1. A rising CWG data input creates a rising event on the modulated output.
2. Output signals shown as active-high; all POLy bits are clear.

**31.2.3.1 Direction Change in Full-Bridge Mode**

In Full-Bridge mode, changing  $MODE$  controls the forward/reverse direction. Direction changes occur on the next rising edge of the modulated input.

A direction change is initiated in software by changing the MODE bits. The sequence is illustrated in [Figure 31-8](#).

- The associated active output CWGxA and the inactive output CWGxC are switched to drive in the opposite direction.
- The previously modulated output CWGxD is switched to the inactive state, and the previously inactive output CWGxB begins to modulate.
- CWG modulation resumes after the direction-switch dead band has elapsed.

#### **31.2.3.2 Dead-Band Delay in Full-Bridge Mode**

Dead-band delay is important when either of the following conditions is true:

1. The direction of the CWG output changes when the duty cycle of the data input is at or near 100%,  
or
2. The turn-off time of the power switch, including the power device and driver circuit, is greater than the turn-on time.

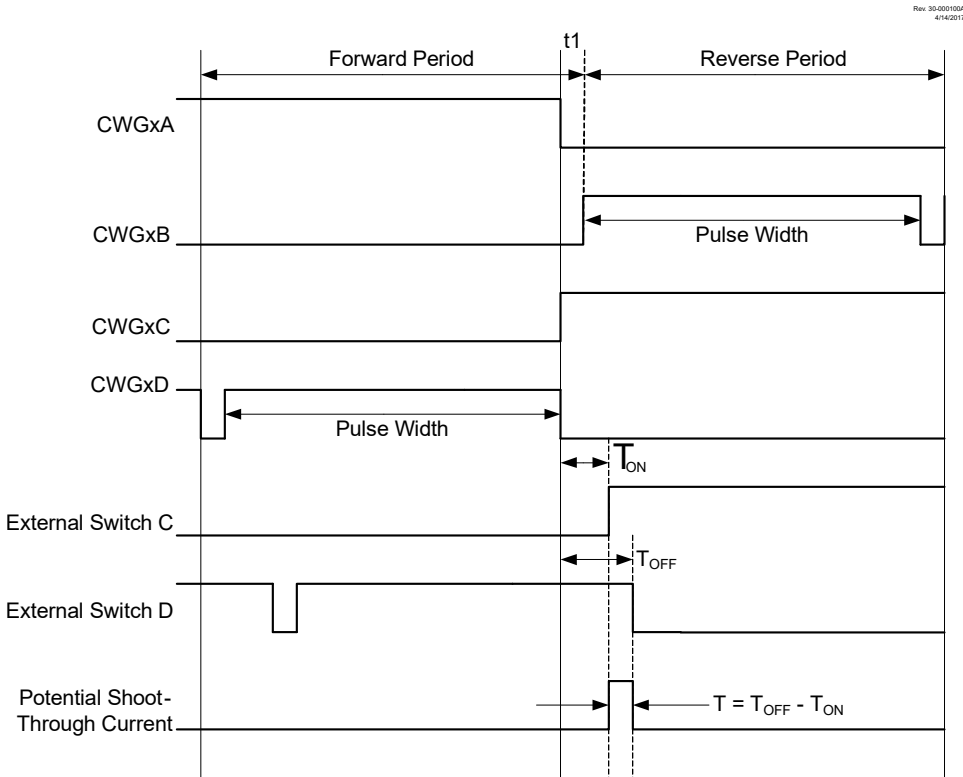
The dead-band delay is inserted only when changing directions, and only the modulated output is affected. The statically-configured outputs (CWGxA and CWGxC) are not afforded dead band, and switch essentially simultaneously.

The following figure shows an example of the CWG outputs changing directions from forward to reverse, at near 100% duty cycle. In this example, at time t1, the output of CWGxA and CWGxD become inactive, while output CWGxC becomes active. Since the turn-off time of the power devices is longer than the turn-on time, a shoot-through current will flow through power devices QC and QD for the duration of 't'. The same phenomenon will occur to power devices QA and QB for the CWG direction change from reverse to forward.

When changing the CWG direction at high duty cycle is required for an application, two possible solutions for eliminating the shoot-through current are:

1. Reduce the CWG duty cycle for one period before changing directions.
2. Use switch drivers that can drive the switches off faster than they can drive them on.

**Figure 31-8. Example of PWM Direction Change at Near 100% Duty Cycle**



### 31.2.4 Steering Modes

In both Synchronous and Asynchronous Steering modes, the modulated input signal can be steered to any combination of four CWG outputs. A fixed-value will be presented on all the outputs not used for the PWM output. Each output has independent polarity, steering, and shutdown options. Dead-band control is not used in either steering mode.

# PIC16(L)F18455/56

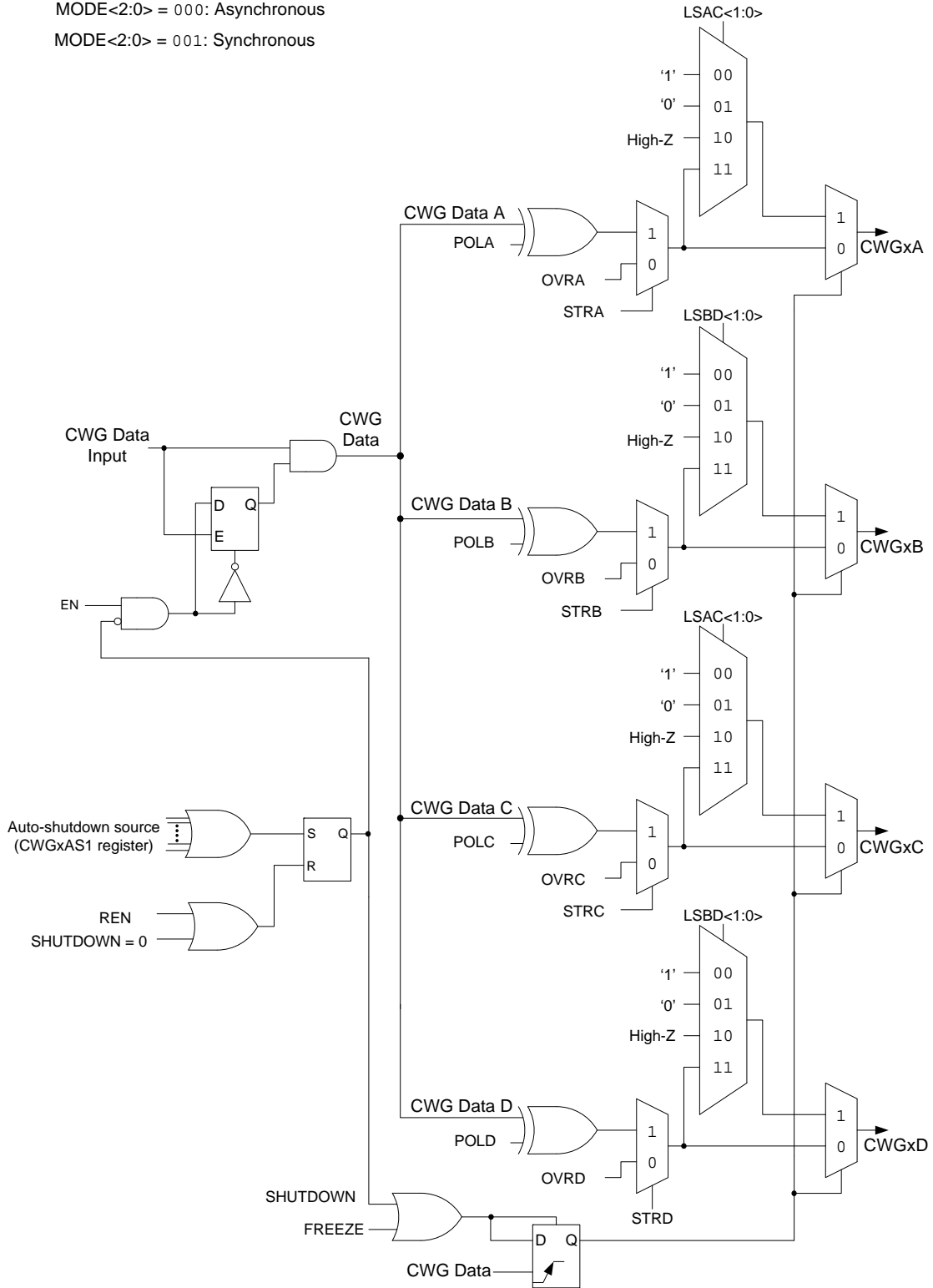
## (CWG) Complementary Waveform Generator Modul...

**Figure 31-9. Simplified CWG Block Diagram (Output Steering Modes)**

MODE<2:0> = 000: Asynchronous

MODE<2:0> = 001: Synchronous

Rev. 10-000211D  
2/30/2017



For example, when **STRA** = 0 then the corresponding pin is held at the level defined by **OVRA**. When **STRA** = 1, then the pin is driven by the modulated input signal.

The **POLy** bits control the signal polarity only when **STRy** = 1.

The CWG auto-shutdown operation also applies in Steering modes as described in 31.11 Auto-Shutdown". An auto-shutdown event will only affect pins that have **STRy** = 1.

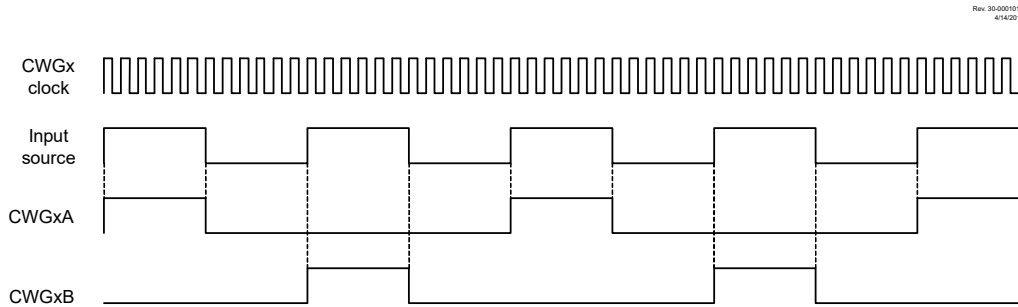
**31.2.4.1 Synchronous Steering Mode**

In Synchronous Steering mode (**MODE=001**), changes to steering selection registers take effect on the next rising edge of the modulated data input (see figure below). In Synchronous Steering mode, the output will always produce a complete waveform.



**Important:** Only the **STRx** bits are synchronized; the **OVRx** bits are not synchronized.

**Figure 31-10. Example of Synchronous Steering (MODE = 001)**

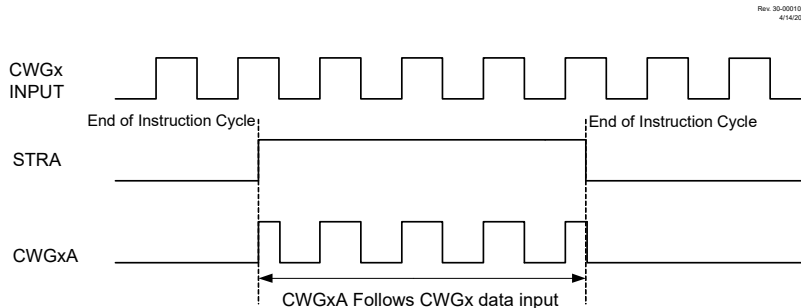


Rev. 30-000101A  
4/14/2017

**31.2.4.2 Asynchronous Steering Mode**

In Asynchronous mode (**MODE = 000**), steering takes effect at the end of the instruction cycle that writes to **STRx**. In Asynchronous Steering mode, the output signal may be an incomplete waveform (see figure below). This operation may be useful when the user firmware needs to immediately remove a signal from the output pin.

**Figure 31-11. Example of Asynchronous Steering (MODE = 000)**



Rev. 30-000102A  
4/14/2017

### 31.3 Start-up Considerations

The application hardware must use the proper external pull-up and/or pull-down resistors on the CWG output pins. This is required because all I/O pins are forced to high-impedance at Reset.

The polarity control bits (**POLy**) allow the user to choose whether the output signals are active-high or active-low.

### 31.4 Clock Source

The clock source is used to drive the dead-band timing circuits. The CWG module allows the following clock sources to be selected:

- F<sub>OSC</sub> (system clock)
- HFINTOSC

When the HFINTOSC is selected, the HFINTOSC will be kept running during Sleep. Therefore, CWG modes requiring dead band can operate in Sleep, provided that the CWG data input is also active during Sleep. The clock sources are selected using the **CS** bit. The system clock F<sub>OSC</sub>, is disabled in Sleep and thus dead-band control cannot be used.

### 31.5 Selectable Input Sources

The CWG generates the output waveforms from the input sources which are selected with the **ISM** bits as shown below.

**Table 31-1. CWG Data Input Sources**

ISM	Data Source
1111	CCP5_out
1110	CLC4_out
1101	CLC3_out
1100	CLC2_out
1011	CLC1_out
1010	DSM1_out
1001	C2_out
1000	C1_out
0111	NCO1_out
0110	PWM7_out
0101	PWM6_out
0100	CCP4_out
0011	CCP3_out
0010	CCP2_out



ISM	Data Source
0001	CCP1_out
0000	Pin selected by CWGxINPPS

## 31.6 Output Control

### 31.6.1 CWG Outputs

Each CWG output can be routed to a Peripheral Pin Select (PPS) output via the RxyPPS register.

#### Related Links

[15. \(PPS\) Peripheral Pin Select Module](#)

### 31.6.2 Polarity Control

The polarity of each CWG output can be selected independently. When the output polarity bit is set, the corresponding output is active-high. Clearing the output polarity bit configures the corresponding output as active-low. However, polarity does not affect the override levels. Output polarity is selected with the **POLy** bits. Auto-shutdown and steering options are unaffected by polarity.

## 31.7 Dead-Band Control

The dead-band control provides non-overlapping PWM signals to prevent shoot-through current in PWM switches. Dead-band operation is employed for Half-Bridge and Full-Bridge modes. The CWG contains two 6-bit dead-band counters. One is used for the rising edge of the input source control in Half-Bridge mode or for reverse dead-band Full-Bridge mode. The other is used for the falling edge of the input source control in Half-Bridge mode or for forward dead band in Full-Bridge mode.

Dead band is timed by counting CWG clock periods from zero up to the value in the rising or falling dead-band counter registers.

### 31.7.1 Dead-Band Functionality in Half-Bridge mode

In Half-Bridge mode, the dead-band counters dictate the delay between the falling edge of the normal output and the rising edge of the inverted output. This can be seen in [Figure 31-1](#).

### 31.7.2 Dead-Band Functionality in Full-Bridge mode

In Full-Bridge mode, the dead-band counters are used when undergoing a direction change. The **MODE<0>** bit can be set or cleared while the CWG is running, allowing for changes from Forward to Reverse mode. The CWGxA and CWGxC signals will change immediately upon the first rising input edge following a direction change, but the modulated signals (CWGxB or CWGxD, depending on the direction of the change) will experience a delay dictated by the dead-band counters.

## 31.8 Rising Edge and Reverse Dead Band

In Half-Bridge mode, the rising edge dead band delays the turn-on of the CWGxA output after the rising edge of the CWG data input. In Full-Bridge mode, the reverse dead-band delay is only inserted when changing directions from Forward mode to Reverse mode, and only the modulated output CWGxB is affected.

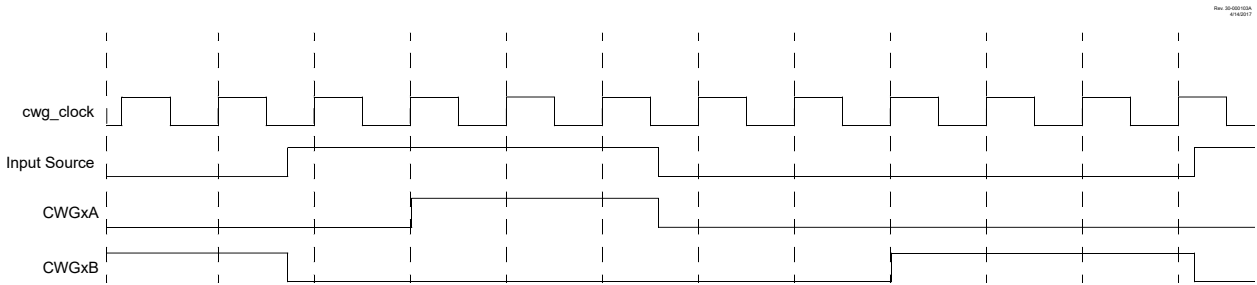
The [31.15.8 CWGxDBR](#) register determines the duration of the dead-band interval on the rising edge of the input source signal. This duration is from 0 to 64 periods of the CWG clock.

Dead band is always initiated on the edge of the input source signal. A count of zero indicates that no dead band is present.

If the input source signal reverses polarity before the dead-band count is completed, then no signal will be seen on the respective output.

The CWGxDBR register value is double-buffered. When EN = 0, the buffer is loaded when CWGxDBR is written. When EN = 1, then the buffer will be loaded at the rising edge following the first falling edge of the data input, after the LD bit is set. Refer to the following figure for an example.

**Figure 31-12. Dead-Band Operation, CWGxDBR = 0x01, CWGxDBF = 0x02**



### 31.9 Falling Edge and Forward Dead Band

In Half-Bridge mode, the falling edge dead band delays the turn-on of the CWGxB output at the falling edge of the CWG data input. In Full-Bridge mode, the forward dead-band delay is only inserted when changing directions from Reverse mode to Forward mode, and only the modulated output CWGxD is affected.

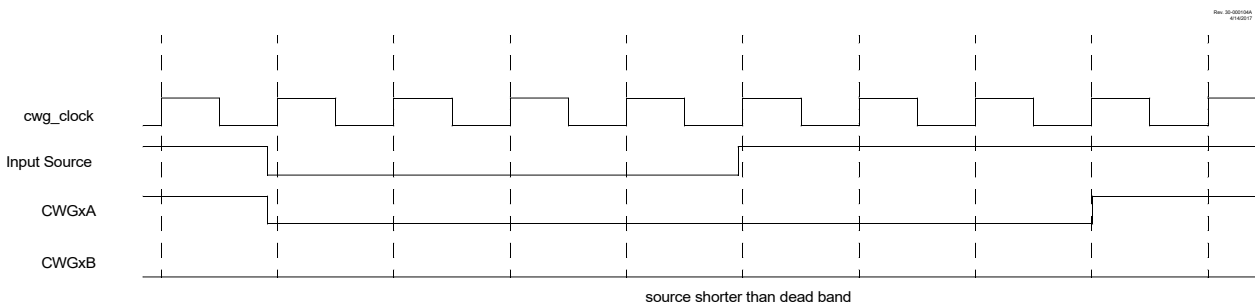
The 31.15.9 CWGxDBF register determines the duration of the dead-band interval on the falling edge of the input source signal. This duration is from zero to 64 periods of CWG clock.

Dead-band delay is always initiated on the edge of the input source signal. A count of zero indicates that no dead band is present.

If the input source signal reverses polarity before the dead-band count is completed, then no signal will be seen on the respective output.

The CWGxDBF register value is double-buffered. When EN = 0, the buffer is loaded when CWGxDBF is written. When EN = 1, then the buffer will be loaded at the rising edge following the first falling edge of the data input after the LD is set. Refer to the following figure for an example.

**Figure 31-13. Dead-Band Operation, CWGxDBR = 0x03, CWGxDBF = 0x06, Source Shorter Than Dead Band**



### 31.10 Dead-Band Jitter

When the rising and falling edges of the input source are asynchronous to the CWG clock, it creates jitter in the dead-band time delay. The maximum jitter is equal to one CWG clock period. Refer to the equations below for more details.

#### Equation 31-1. Dead-Band Delay Time Calculation

$$T_{DEAD - BAND\_MIN} = \frac{1}{F_{CWG\_CLOCK}} \cdot DBx < 5:0 >$$

$$T_{DEAD - BAND\_MAX} = \frac{1}{F_{CWG\_CLOCK}} \cdot DBx < 5:0 > + 1$$

$$T_{JITTER} = T_{DEAD - BAND\_MAX} - T_{DEAD - BAND\_MIN}$$

$$T_{JITTER} = \frac{1}{F_{CWG\_CLOCK}}$$

$$T_{DEAD - BAND\_MAX} = T_{DEAD - BAND\_MIN} + T_{JITTER}$$

#### Equation 31-2. Dead-Band Delay Example Calculation

$$DBx < 5:0 > = 0x0A = 10$$

$$F_{CWG\_CLOCK} = 8\text{ MHz}$$

$$T_{JITTER} = \frac{1}{8\text{ MHz}} = 125\text{ ns}$$

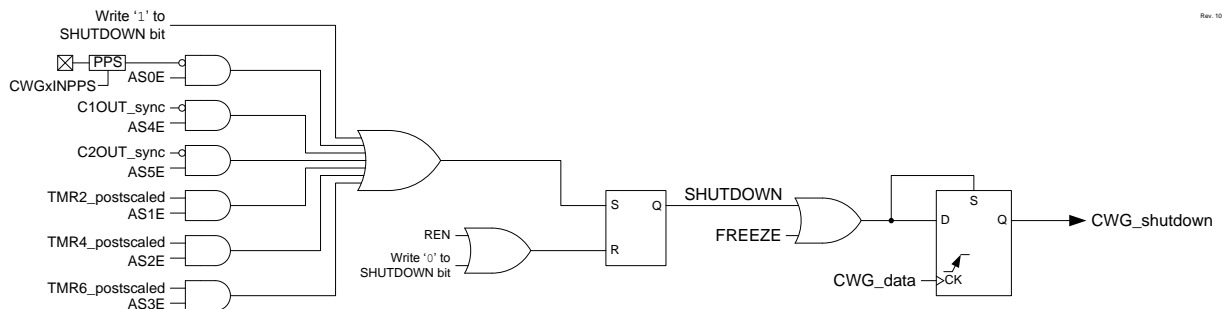
$$T_{DEAD - BAND\_MIN} = 125\text{ ns} \cdot 10 = 125\text{ }\mu\text{s}$$

$$T_{DEAD - BAND\_MAX} = 1.25\text{ }\mu\text{s} + 0.125\text{ }\mu\text{s} = 1.37\text{ }\mu\text{s}$$

### 31.11 Auto-Shutdown

Auto-shutdown is a method to immediately override the CWG output levels with specific overrides that allow for safe shutdown of the circuit. The shutdown state can be either cleared automatically or held until cleared by software. The auto-shutdown circuit is illustrated in the following figure.

Figure 31-14. CWG Shutdown Block Diagram



#### 31.11.1 Shutdown

The shutdown state can be entered by either of the following two methods:

- Software Generated

- External Input

### 31.11.1.1 Software Generated Shutdown

Setting the **SHUTDOWN** bit will force the CWG into the shutdown state.

When the auto-restart is disabled, the shutdown state will persist as long as the SHUTDOWN bit is set.

When auto-restart is enabled, the SHUTDOWN bit will clear automatically and resume operation on the next rising edge event. The SHUTDOWN bit indicates when a shutdown condition exists. The bit may be set or cleared in software or by hardware.

### 31.11.1.2 External Input Source

External shutdown inputs provide the fastest way to safely suspend CWG operation in the event of a Fault condition. When any of the selected shutdown inputs goes active, the CWG outputs will immediately go to the selected override levels without software delay. The override levels are selected by the **LSBD** and **LSAC** bits. Several input sources can be selected to cause a shutdown condition. All input sources are active-low. The shutdown input sources are individually enabled by the **ASyE** bits as shown in the following table:

**Table 31-2. Shutdown Sources**

ASyE	Source
AS6E	CLC2_out/CLC3_out (low causes shutdown)
AS5E	CMP2_out (low causes shutdown)
AS4E	CMP1_out (low causes shutdown)
AS3E	TMR6_postscaled (high causes shutdown)
AS2E	TMR4_postscaled (high causes shutdown)
AS1E	TMR2_postscaled (high causes shutdown)
AS0E	Pin selected by CWGxPPS (low causes shutdown)



**Important:** Shutdown inputs are level sensitive, not edge sensitive. The shutdown state cannot be cleared, except by disabling auto-shutdown, as long as the shutdown input level persists.

### 31.11.1.3 Pin Override Levels

The levels driven to the CWG outputs during an auto-shutdown event are controlled by the **LSBD** and **LSAC** bits. The LSBD bits control CWGxB/D output levels, while the LSAC bits control the CWGxA/C output levels.

### 31.11.1.4 Auto-Shutdown Interrupts

When an auto-shutdown event occurs, either by software or hardware setting SHUTDOWN, the CWGxIF flag bit of the PIRx register is set.

### 31.11.2 Auto-Shutdown Restart

After an auto-shutdown event has occurred, there are two ways to resume operation:

- Software controlled
- Auto-restart

In either case, the shutdown source must be cleared before the restart can take place. That is, either the shutdown condition must be removed, or the corresponding ASyE bit must be cleared.

**31.11.2.1 Software-Controlled Restart**

When the REN bit is clear (REN = 0), the CWG module must be restarted after an auto-shutdown event through software.

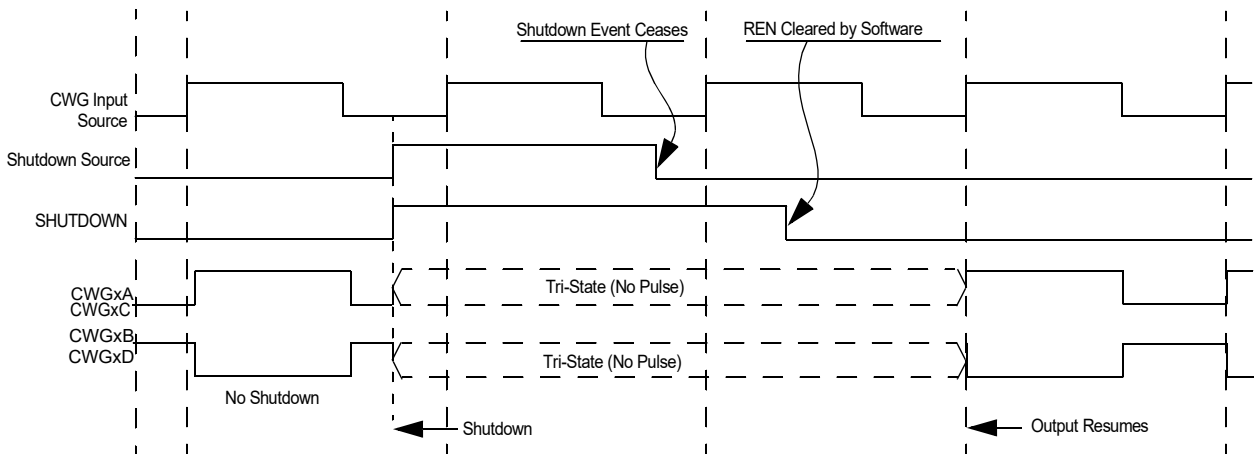
Once all auto-shutdown sources are removed, the software must clear SHUTDOWN. Once SHUTDOWN is cleared, the CWG module will resume operation upon the first rising edge of the CWG data input.



**Important:** The SHUTDOWN bit cannot be cleared in software if the auto-shutdown condition is still present.

**Figure 31-15. SHUTDOWN FUNCTIONALITY, AUTO-RESTART DISABLED (REN = 0, LSAC = 01, LSBSD = 01)**

Rev 30-000105A  
4/14/2017



**31.11.2.2 Auto-Restart**

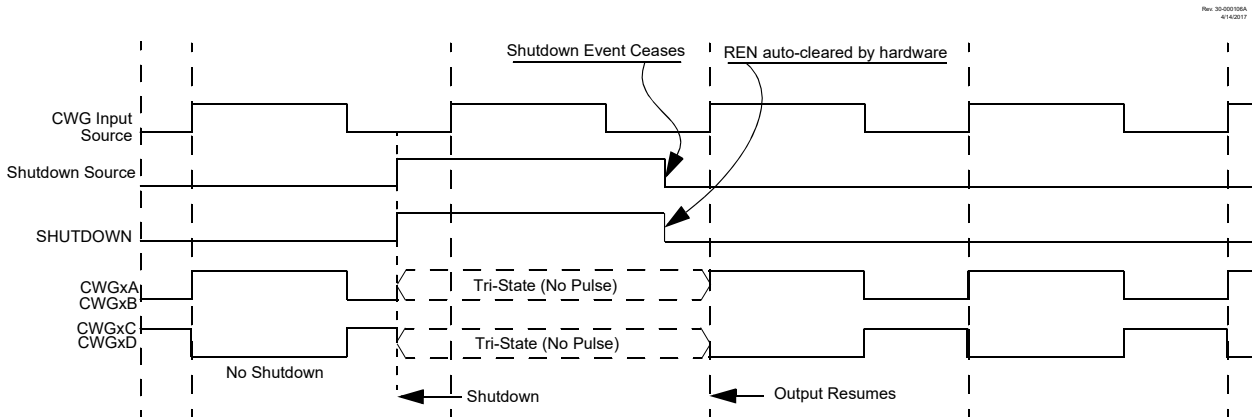
When the REN bit is set (REN = 1), the CWG module will restart from the shutdown state automatically.

Once all auto-shutdown conditions are removed, the hardware will automatically clear SHUTDOWN. Once SHUTDOWN is cleared, the CWG module will resume operation upon the first rising edge of the CWG data input.



**Important:** The SHUTDOWN bit cannot be cleared in software if the auto-shutdown condition is still present.

**Figure 31-16. SHUTDOWN FUNCTIONALITY, AUTO-RESTART ENABLED (REN = 1, LSAC = 01, LSBSD = 01)**



### 31.12 Operation During Sleep

The CWG module operates independently from the system clock and will continue to run during Sleep, provided that the clock and input sources selected remain active.

The HFINTOSC remains active during Sleep when all the following conditions are met:

- CWG module is enabled
- Input source is active
- HFINTOSC is selected as the clock source, regardless of the system clock source selected.

In other words, if the HFINTOSC is simultaneously selected as the system clock and the CWG clock source, when the CWG is enabled and the input source is active, then the CPU will go idle during Sleep, but the HFINTOSC will remain active and the CWG will continue to operate. This will have a direct effect on the Sleep mode current.

### 31.13 Configuring the CWG

1. Ensure that the TRIS control bits corresponding to CWG outputs are set so that all are configured as inputs, ensuring that the outputs are inactive during setup. External hardware should ensure that pin levels are held to safe levels.
2. Clear the **EN** bit, if not already cleared.
3. Configure the **MODE** bits to set the output operating mode.
4. Configure the **POLy** bits to set the output polarities.
5. Configure the **ISM** bits to select the data input source.
6. If a steering mode is selected, configure the **STRy** bits to select the desired output on the CWG outputs.
7. Configure the **LSBD** and **LSAC** bits to select the auto-shutdown output override states (this is necessary even if not using auto-shutdown because start-up will be from a shutdown state).
8. If auto-restart is desired, set the **REN** bit.
9. If auto-shutdown is desired, configure the **ASyE** bits to select the shutdown source.
10. Set the desired rising and falling dead-band times with the CWGxDBR and CWGxDBF registers.

# PIC16(L)F18455/56

## (CWG) Complementary Waveform Generator Modul...

---

11. Select the clock source with the **CS** bits.
12. Set the EN bit to enable the module.
13. Clear the TRIS bits that correspond to the CWG outputs to set them as outputs.

If auto-restart is to be used, set the REN bit and the SHUTDOWN bit will be cleared automatically. Otherwise, clear the SHUTDOWN bit in software to start the CWG.

31.14 Register Summary - CWG Control

Address	Name	Bit Pos.								
0x060C	CWG1CLK	7:0								CS
0x060D	CWG1ISM	7:0						ISM[3:0]		
0x060E	CWG1DBR	7:0						DBR[5:0]		
0x060F	CWG1DBF	7:0						DBF[5:0]		
0x0610	CWG1CON0	7:0	EN	LD				MODE[2:0]		
0x0611	CWG1CON1	7:0			IN		POLD	POLC	POLB	POLA
0x0612	CWG1AS0	7:0	SHUTDOWN	REN	LSBD[1:0]		LSAC[1:0]			
0x0613	CWG1AS1	7:0			AS5E	AS4E	AS3E	AS2E	AS1E	AS0E
0x0614	CWG1STR	7:0	OVRD	OVRT	OVRB	OVRT	STRD	STRC	STRB	STRA
0x0615	Reserved									
0x0616	CWG2CLK	7:0								CS
0x0617	CWG2ISM	7:0						ISM[3:0]		
0x0618	CWG2DBR	7:0						DBR[5:0]		
0x0619	CWG2DBF	7:0						DBF[5:0]		
0x061A	CWG2CON0	7:0	EN	LD				MODE[2:0]		
0x061B	CWG2CON1	7:0			IN		POLD	POLC	POLB	POLA
0x061C	CWG2AS0	7:0	SHUTDOWN	REN	LSBD[1:0]		LSAC[1:0]			
0x061D	CWG2AS1	7:0			AS5E	AS4E	AS3E	AS2E	AS1E	AS0E
0x061E	CWG2STR	7:0	OVRD	OVRT	OVRB	OVRT	STRD	STRC	STRB	STRA
0x061F ... 0x068B	Reserved									
0x068C	CWG3CLK	7:0								CS
0x068D	CWG3ISM	7:0						ISM[3:0]		
0x068E	CWG3DBR	7:0						DBR[5:0]		
0x068F	CWG3DBF	7:0						DBF[5:0]		
0x0690	CWG3CON0	7:0	EN	LD				MODE[2:0]		
0x0691	CWG3CON1	7:0			IN		POLD	POLC	POLB	POLA
0x0692	CWG3AS0	7:0	SHUTDOWN	REN	LSBD[1:0]		LSAC[1:0]			
0x0693	CWG3AS1	7:0			AS5E	AS4E	AS3E	AS2E	AS1E	AS0E
0x0694	CWG3STR	7:0	OVRD	OVRT	OVRB	OVRT	STRD	STRC	STRB	STRA

31.15 Register Definitions: CWG Control

Long bit name prefixes for the CWG peripherals are shown in the table below. Refer to the "Long Bit Names Section" for more information.

Table 31-3. CWG Bit Name Prefixes

Peripheral	Bit Name Prefix
CWG1	CWG1
CWG2	CWG2
CWG3	CWG3



**Related Links**

[1.4.2.2 Long Bit Names](#)

**31.15.1 CWGxCON0**

**Name:** CWGxCON0  
**Address:** 0x610,0x61A,0x690

CWG Control Register 0

Bit	7	6	5	4	3	2	1	0
	EN	LD				MODE[2:0]		
Access	R/W	R/W/HC				R/W	R/W	R/W
Reset	0	0				0	0	0

**Bit 7 – EN** CWG1 Enable bit

Value	Description
1	Module is enabled
0	Module is disabled

**Bit 6 – LD** CWG1 Load Buffers bit<sup>(1)</sup>

Value	Description
1	Dead-band count buffers to be loaded on CWG data rising edge, following first falling edge after this bit is set
0	Buffers remain unchanged

**Bits 2:0 – MODE[2:0]** CWG1 Mode bits

Value	Description
111	Reserved
110	Reserved
101	CWG outputs operate in Push-Pull mode
100	CWG outputs operate in Half-Bridge mode
011	CWG outputs operate in Reverse Full-Bridge mode
010	CWG outputs operate in Forward Full-Bridge mode
001	CWG outputs operate in Synchronous Steering mode
000	CWG outputs operate in Asynchronous Steering mode

**Note:**

1. This bit can only be set after EN = 1; it cannot be set in the same cycle when EN is set.

31.15.2 CWGxCON1

**Name:** CWGxCON1  
**Address:** 0x611,0x61B,0x691

CWG Control Register 1

Bit	7	6	5	4	3	2	1	0
			IN		POLD	POLC	POLB	POLA
Access			RO		R/W	R/W	R/W	R/W
Reset			x		0	0	0	0

**Bit 5 – IN** CWG Input Value bit (read-only)

Value	Description
1	CWG input is a logic 1
0	CWG input is a logic 0

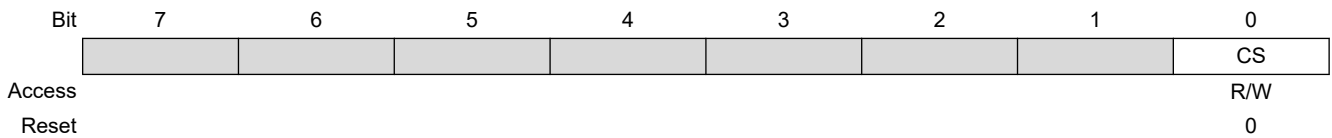
**Bits 0, 1, 2, 3 – POLy** CWG Output 'y' Polarity bit

Value	Description
1	Signal output is inverted polarity
0	Signal output is normal polarity

**31.15.3 CWGxCLK**

**Name:** CWGxCLK  
**Address:** 0x60C,0x616,0x68C

CWGx Clock Input Selection Register



**Bit 0 – CS** Clock Source  
 CWG Clock Source Selection Select bits

Value	Description
1	HFINTOSC (remains operating during Sleep)
0	F <sub>Osc</sub>

**31.15.4 CWGxISM**

**Name:** CWGxISM  
**Address:** 0x60D,0x617,0x68D

CWGx Input Selection Register

	7	6	5	4	3	2	1	0
					ISM[3:0]			
Access					R/W	R/W	R/W	R/W
Reset					0	0	0	0

**Bits 3:0 – ISM[3:0]** CWG Data Input Source Select bits

**Table 31-4. CWG Data Input Sources**

ISM	Data Source
1111	CCP5_out
1110	CLC4_out
1101	CLC3_out
1100	CLC2_out
1011	CLC1_out
1010	DSM1_out
1001	C2_out
1000	C1_out
0111	NCO1_out
0110	PWM7_out
0101	PWM6_out
0100	CCP4_out
0011	CCP3_out
0010	CCP2_out
0001	CCP1_out
0000	Pin selected by CWGxINPPS

### 31.15.5 CWGxSTR

**Name:** CWGxSTR  
**Address:** 0x614,0x61E,0x694

CWG Steering Control Register <sup>(1)</sup>

Bit	7	6	5	4	3	2	1	0
	OVRD	OVRC	OVRB	OVRA	STRD	STRC	STRB	STRA
Access	R/W	R/W	R/W	R/W	R/W	R/W	R/W	R/W
Reset	0	0	0	0	0	0	0	0

**Bits 4, 5, 6, 7 – OVRy** Steering Data OVR'y' bit

Value	Condition	Description
x	STRy = 1	CWGx'y' output has the CWG data input waveform with polarity control from POLy bit
1	STRy = 0 and POLy = x	CWGx'y' output is high
0	STRy = 0 and POLy = x	CWGx'y' output is low

**Bits 0, 1, 2, 3 – STRy** STR'y' Steering Enable bit<sup>(2)</sup>

Value	Description
1	CWGx'y' output has the CWG data input waveform with polarity control from POLy bit
0	CWGx'y' output is assigned to value of OVRy bit

**Note:**

1. The bits in this register apply only when MODE = '00x' ([31.15.1 CWGxCON0](#), Steering modes).
2. This bit is double-buffered when MODE = '001'.

31.15.6 CWGxAS0

**Name:** CWGxAS0  
**Address:** 0x612,0x61C,0x692

CWG Auto-Shutdown Control Register 0

Bit	7	6	5	4	3	2	1	0
	SHUTDOWN	REN	LSBD[1:0]		LSAC[1:0]			
Access	R/W/HS/HC	R/W	R/W	R/W	R/W	R/W		
Reset	0	0	0	1	0	1		

**Bit 7 – SHUTDOWN** Auto-Shutdown Event Status bit<sup>(1,2)</sup>

Value	Description
1	An auto-shutdown state is in effect
0	No auto-shutdown event has occurred

**Bit 6 – REN** Auto-Restart Enable bit

Value	Description
1	Auto-restart is enabled
0	Auto-restart is disabled

**Bits 5:4 – LSBD[1:0]** CWGxB and CWGxD Auto-Shutdown State Control bits

Value	Description
11	A logic '1' is placed on CWGxB/D when an auto-shutdown event occurs.
10	A logic '0' is placed on CWGxB/D when an auto-shutdown event occurs.
01	Pin is tri-stated on CWGxB/D when an auto-shutdown event occurs.
00	The inactive state of the pin, including polarity, is placed on CWGxB/D after the required dead-band interval when an auto-shutdown event occurs.

**Bits 3:2 – LSAC[1:0]** CWGxA and CWGxC Auto-Shutdown State Control bits

Value	Description
11	A logic '1' is placed on CWGxA/C when an auto-shutdown event occurs.
10	A logic '0' is placed on CWGxA/C when an auto-shutdown event occurs.
01	Pin is tri-stated on CWGxA/C when an auto-shutdown event occurs.
00	The inactive state of the pin, including polarity, is placed on CWGxA/C after the required dead-band interval when an auto-shutdown event occurs.

**Note:**

1. This bit may be written while EN = 0 ([31.15.1 CWGxCON0](#)), to place the outputs into the shutdown configuration.
2. The outputs will remain in auto-shutdown state until the next rising edge of the CWG data input after this bit is cleared.

31.15.7 CWGxAS1

**Name:** CWGxAS1  
**Address:** 0x613,0x61D,0x693

CWG Auto-Shutdown Control Register 1

Bit	7	6	5	4	3	2	1	0
			AS5E	AS4E	AS3E	AS2E	AS1E	AS0E
Access			R/W	R/W	R/W	R/W	R/W	R/W
Reset			0	0	0	0	0	0

**Bits 0, 1, 2, 3, 4, 5 – ASyE** CWG Auto-shutdown Source ASyE Enable bit(1)

**Table 31-5. Shutdown Sources**

ASyE	Source
AS6E	CLC2_out/CLC3_out (low causes shutdown)
AS5E	CMP2_out (low causes shutdown)
AS4E	CMP1_out (low causes shutdown)
AS3E	TMR6_postscaled (high causes shutdown)
AS2E	TMR4_postscaled (high causes shutdown)
AS1E	TMR2_postscaled (high causes shutdown)
AS0E	Pin selected by CWGxPPS (low causes shutdown)

Value	Description
1	Auto-shutdown for source ASyE is enabled
0	Auto-shutdown for source ASyE is disabled

**Note:** This bit may be written while EN = 0 (31.15.1 CWGxCON0), to place the outputs into the shutdown configuration.

The outputs will remain in auto-shutdown state until the next rising edge of the CWG data input after this bit is cleared.



31.15.8 CWGxDBR

**Name:** CWGxDBR  
**Address:** 0x60E,0x618,0x68E

CWG Rising Dead-Band Count Register

Bit	7	6	5	4	3	2	1	0
			DBR[5:0]					
Access			R/W	R/W	R/W	R/W	R/W	R/W
Reset			x	x	x	x	x	x

**Bits 5:0 – DBR[5:0]** CWG Rising Edge Triggered Dead-Band Count bits  
 Reset States: POR/BOR = xxxxxx  
 All Other Resets = uuuuuu

Value	Description
n	Dead band is active no less than n, and no more than n+1, CWG clock periods after the rising edge
0	0 CWG clock periods. Dead-band generation is bypassed

31.15.9 CWGxDBF

**Name:** CWGxDBF  
**Address:** 0x60F,0x619,0x68F

CWG Falling Dead-Band Count Register

Bit	7	6	5	4	3	2	1	0
			DBF[5:0]					
Access			R/W	R/W	R/W	R/W	R/W	R/W
Reset			x	x	x	x	x	x

**Bits 5:0 – DBF[5:0]** CWG Falling Edge Triggered Dead-Band Count bits  
 Reset States: POR/BOR = xxxxxx  
 All Other Resets = uuuuuu

Value	Description
n	Dead band is active no less than n, and no more than n+1, CWG clock periods after the falling edge
0	0 CWG clock periods. Dead-band generation is bypassed

## 32. (DSM) Data Signal Modulator Module

The Data Signal Modulator (DSM) is a peripheral which allows the user to mix a data stream, also known as a modulator signal, with a carrier signal to produce a modulated output.

Both the carrier and the modulator signals are supplied to the DSM module either internally, from the output of a peripheral, or externally through an input pin.

The modulated output signal is generated by performing a logical “AND” operation of both the carrier and modulator signals and then provided to the MDOOUT pin.

The carrier signal is comprised of two distinct and separate signals. A carrier high (CARH) signal and a carrier low (CARL) signal. During the time in which the modulator (MOD) signal is in a logic high state, the DSM mixes the carrier high signal with the modulator signal. When the modulator signal is in a logic low state, the DSM mixes the carrier low signal with the modulator signal.

Using this method, the DSM can generate the following types of Key Modulation schemes:

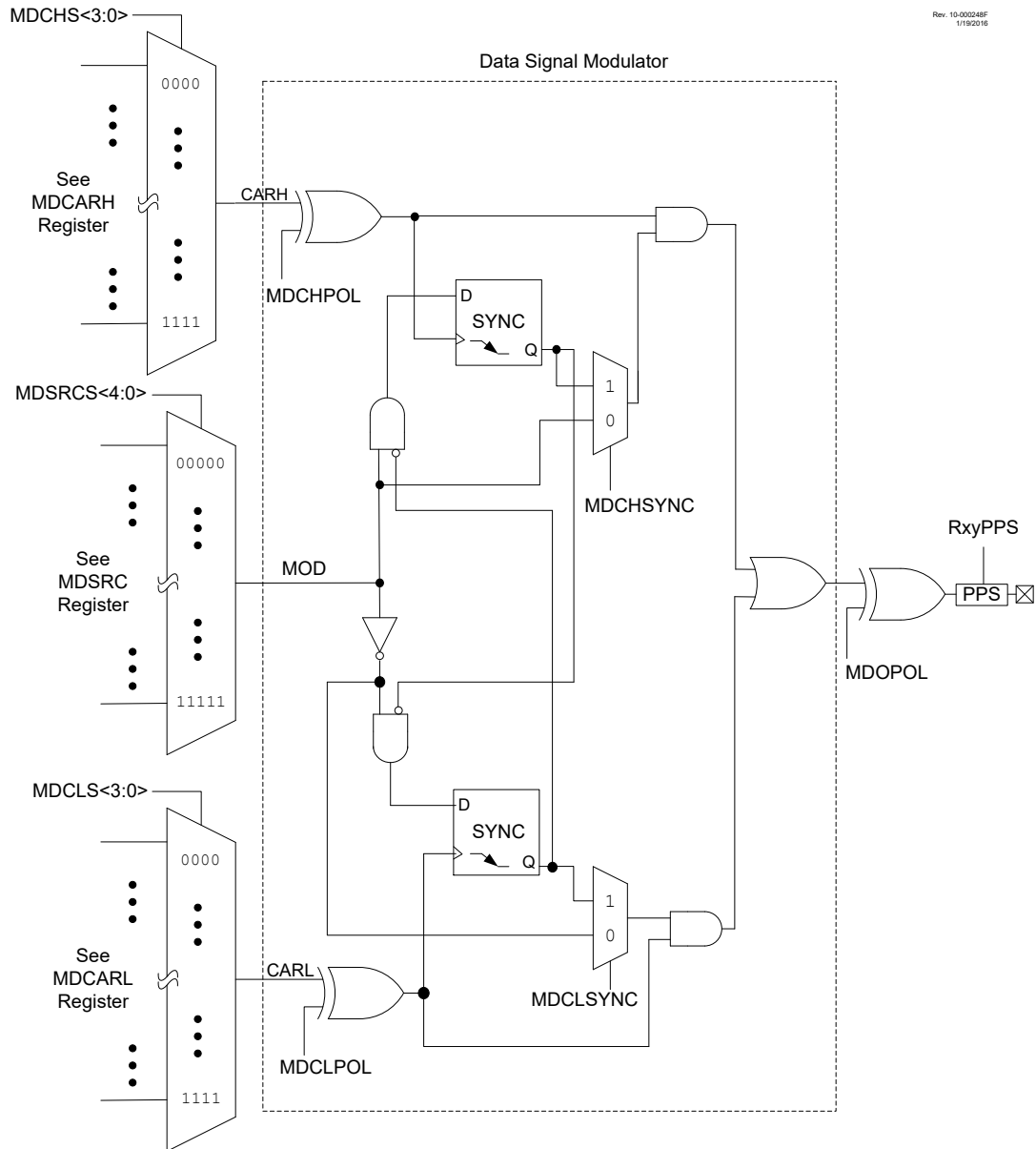
- Frequency-Shift Keying (FSK)
- Phase-Shift Keying (PSK)
- On-Off Keying (OOK)

Additionally, the following features are provided within the DSM module:

- Carrier Synchronization
- Carrier Source Polarity Select
- Programmable Modulator Data
- Modulated Output Polarity Select
- Peripheral Module Disable, which provides the ability to place the DSM module in the lowest power consumption mode

The figure below shows a Simplified Block Diagram of the Data Signal Modulator peripheral.

Figure 32-1. Simplified Block Diagram of the Data Signal Modulator



### 32.1 DSM Operation

The DSM module can be enabled by setting the **EN** bit in the MDCON0 register. Clearing the EN bit, disables the output of the module but retain the carrier and source signal selections. The module will resume operation when the EN bit is set again. The output of the DSM module can be rerouted to several pins using the RxyPPS register. When the EN bit is cleared the output pin is held low.

### 32.2 Modulator Signal Sources

The modulator signal can be supplied from the following sources selected with the **SRCS** bits:

**Table 32-1. MDSRC Selection MUX Connections**

SRCS<4:0>	Connection
11111-10100	Reserved
10011	EUSART2 TX (TX/CK output)
10010	CCP5 OUT
10001	MSSP2 - SDO
10000	MSSP1 - SDO
01111	EUSART1 TX (TX/CK output)
01110	CLC4 OUT
01101	CLC3 OUT
01100	CLC2 OUT
01011	CLC1 OUT
01010	C2 OUT
01001	C1 OUT
01000	NCO1 OUT
00111	PWM7 OUT
00110	PWM6 OUT
00101	CCP4 OUT
00100	CCP3 OUT
00011	CCP2 OUT
00010	CCP1 OUT
00001	MDBIT
00000	Pin selected by MDSRCPPS

### 32.3 Carrier Signal Sources

The carrier high signal and carrier low signal can be supplied from the following sources.

The carrier high signal is selected by configuring the [CHS](#) bits.

**Table 32-2. MDCARH Source Selections**

MDCARH	
CHS<3:0>	Connection
1111	CCP5 OUT
1110	CLC4 OUT
1101	CLC3 OUT

**PIC16(L)F18455/56**  
**(DSM) Data Signal Modulator Module**

MDCARH	
CHS<3:0>	Connection
1100	CLC2 OUT
1011	CLC1 OUT
1010	NCO1 OUT
1001	PWM7 OUT
1000	PWM6 OUT
0111	CCP4 OUT
0110	CCP3 OUT
0101	CCP2 OUT
0100	CCP1 OUT
0011	CLKREF output
0010	HFINTOSC
0001	F <sub>OSC</sub> (system clock)
0000	Pin selected by MDCARHPPS

The carrier low signal is selected by configuring the **CLS** bits.

**Table 32-3. MDCARL Source Selections**

MDCARL	
CLS<3:0>	Connection
1111	CCP5 OUT
1110	CLC4 OUT
1101	CLC3 OUT
1100	CLC2 OUT
1011	CLC1 OUT
1010	NCO1 OUT
1001	PWM7 OUT
1000	PWM6 OUT
0111	CCP4 OUT
0110	CCP3 OUT
0101	CCP2 OUT
0100	CCP1 OUT
0011	CLKREF output

MDCARL	
CLS<3:0>	Connection
0010	HFINTOSC
0001	$F_{OSC}$ (system clock)
0000	Pin selected by MDCARLPPS

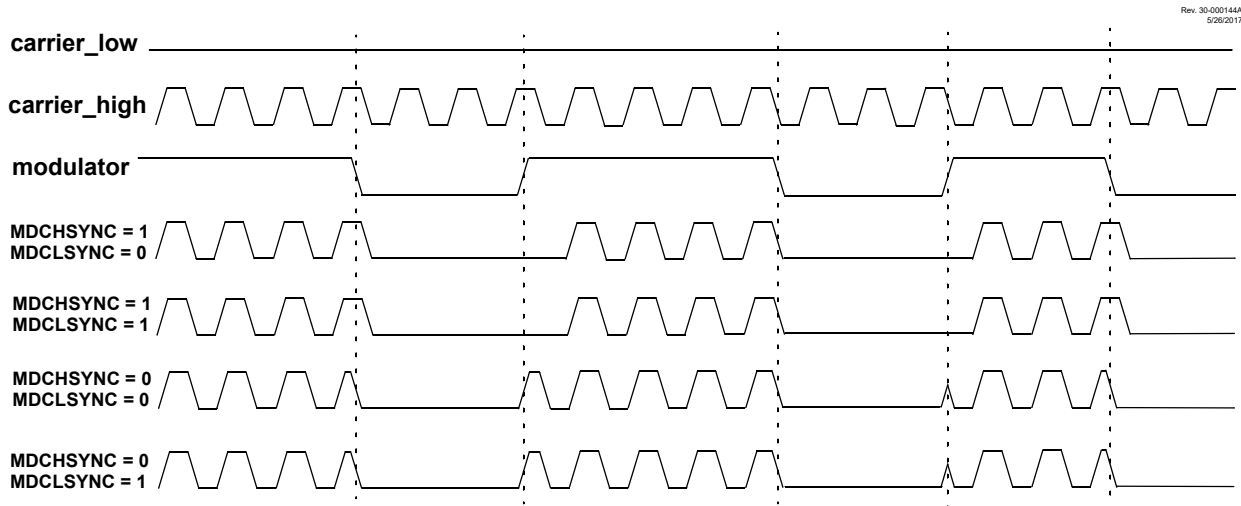
### 32.4 Carrier Synchronization

During the time when the DSM switches between carrier high and carrier low signal sources, the carrier data in the modulated output signal can become truncated. To prevent this, the carrier signal can be synchronized to the modulator signal. When synchronization is enabled, the carrier pulse that is being mixed at the time of the transition is allowed to transition low before the DSM switches over to the next carrier source.

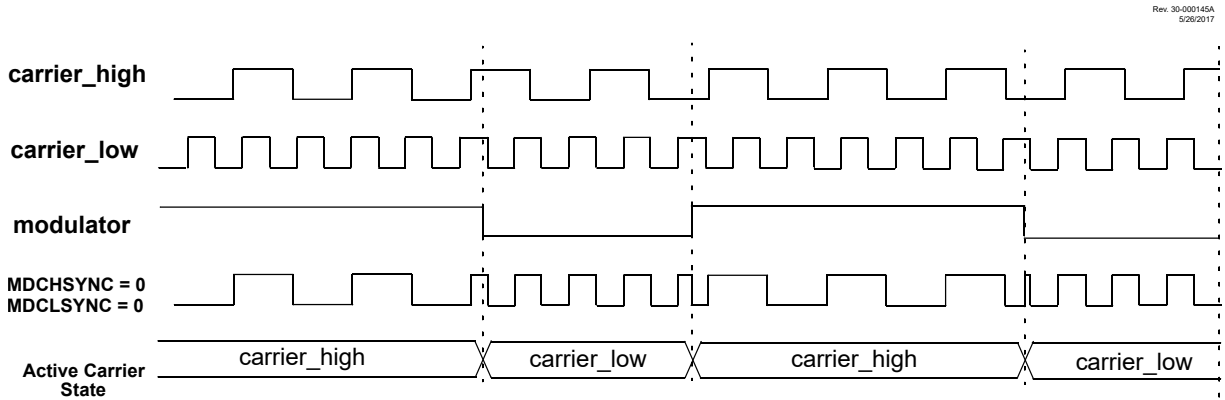
Synchronization is enabled separately for the carrier high and carrier low signal sources. Synchronization for the carrier high signal is enabled by setting the **CHSYNC** bit. Synchronization for the carrier low signal is enabled by setting the **CLSYNC** bit.

The figures below show the timing diagrams of using various synchronization methods.

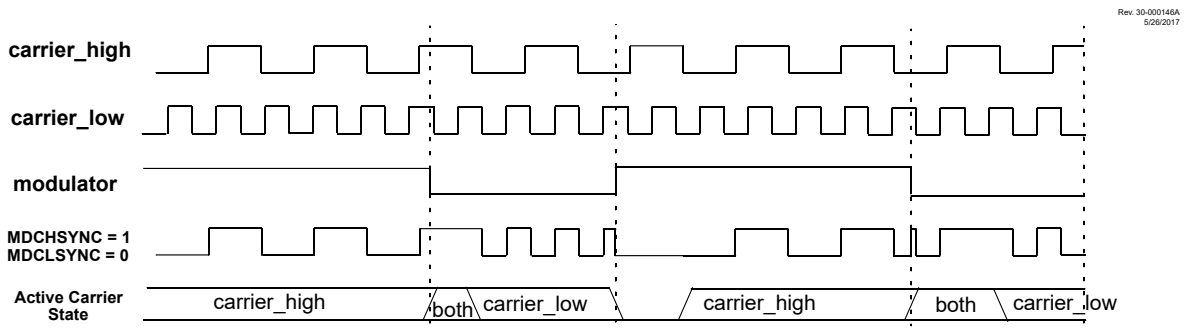
**Figure 32-2. On Off Keying (OOK) Synchronization**



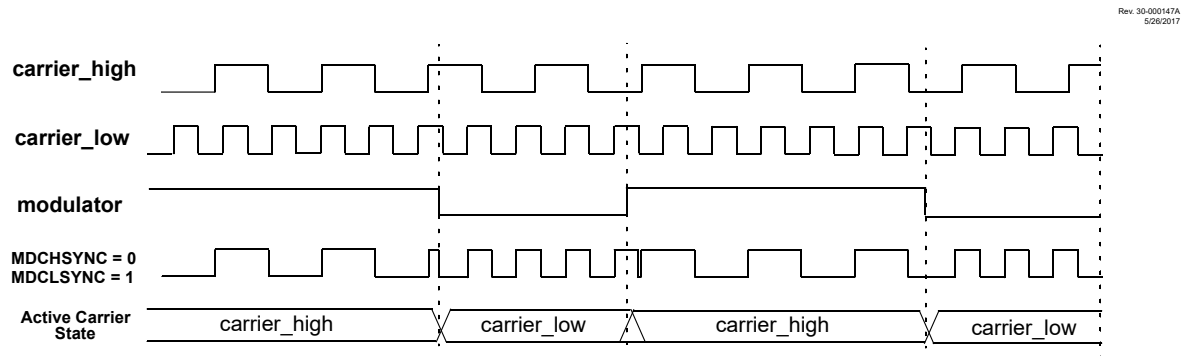
**Figure 32-3. No Synchronization (MDCHSYNC = 0, MDCLSYNC = 0)**



**Figure 32-4. Carrier High Synchronization (MDCHSYNC = 1, MDCLSYNC = 0)**

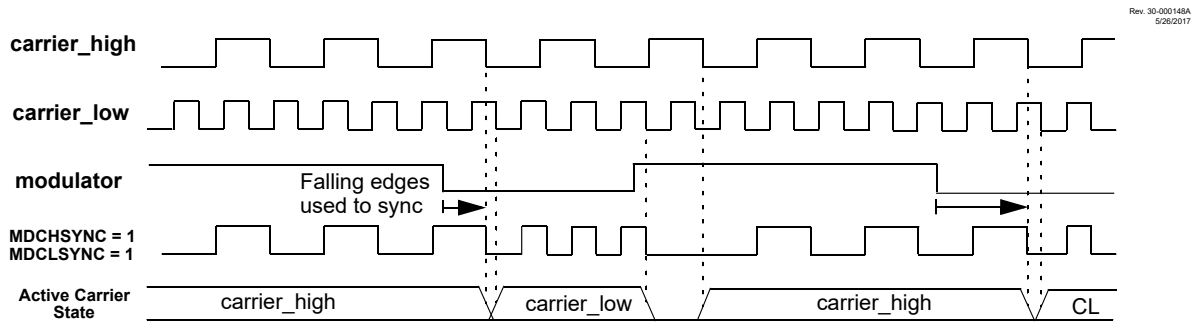


**Figure 32-5. Carrier Low Synchronization (MDCHSYNC = 0, MDCLSYNC = 1)**





**Figure 32-6. Full Synchronization (MDCHSYNC = 1, MDCLSYNC = 1)**



### 32.5 Carrier Source Polarity Select

The signal provided from any selected input source for the carrier high and carrier low signals can be inverted. Inverting the signal for the carrier high and low source is enabled by setting the [CHPOL](#) bit and the [CLPOL](#) bit, respectively.

### 32.6 Programmable Modulator Data

The [BIT](#) bit can be selected as the modulation source. This gives the user the ability to provide software driven modulation.

### 32.7 Modulated Output Polarity

The modulated output signal provided on the DSM pin can also be inverted. Inverting the modulated output signal is enabled by setting the [OPOL](#) bit.

### 32.8 Operation in Sleep Mode

The DSM can still operate during Sleep, if the Carrier and Modulator input sources are also still operable during Sleep. Refer to *“Power-Saving Operation Modes”* for more details.

### 32.9 Effects of a Reset

Upon any device Reset, the DSM module is disabled. The user’s firmware is responsible for initializing the module before enabling the output. All the registers are reset to their default values.

### 32.10 Peripheral Module Disable

The DSM module can be completely disabled using the PMD module to achieve maximum power saving. When the DSMMD bit of PMD<sub>x</sub> register is set, the DSM module is completely disabled. This puts the module in its lowest power consumption state. When enabled again all the registers of the DSM module default to POR status.

#### Related Links

[16.5 Register Definitions: Peripheral Module Disable](#)

### 32.11 Register Summary - DSM

Address	Name	Bit Pos.								
0x0897	<a href="#">MD1CON0</a>	7:0	EN		OUT	OPOL				BIT
0x0898	<a href="#">MD1CON1</a>	7:0			CHPOL	CHSYNC			CLPOL	CLSYNC
0x0899	<a href="#">MD1SRC</a>	7:0					SRCS[4:0]			
0x089A	<a href="#">MD1CARL</a>	7:0					CLS[3:0]			
0x089B	<a href="#">MD1CARH</a>	7:0					CHS[3:0]			

### 32.12 Register Definitions: Modulation Control

Long bit name prefixes for the Modulation Control peripherals are shown in the table below. Refer to the "Long Bit Names Section" for more information.

**Table 32-4. Modulation Control Long Bit Name Prefixes**

Peripheral	Bit Name Prefix
MD	MD

#### Related Links

[1.4.2.2 Long Bit Names](#)

### 32.12.1 MDxCON0

**Name:** MDxCON0  
**Address:** 0x0897

Modulation Control Register 0

Bit	7	6	5	4	3	2	1	0
	EN		OUT	OPOL				BIT
Access	R/W		R/W	R/W				R/W
Reset	0		0	0				0

**Bit 7 – EN** Modulator Module Enable bit

Value	Description
1	Modulator module is enabled and mixing input signals
0	Modulator module is disabled and has no output

**Bit 5 – OUT** Modulator Output bit  
 Displays the current output value of the modulator module.

**Bit 4 – OPOL** Modulator Output Polarity Select bit

Value	Description
1	Modulator output signal is inverted; idle high output
0	Modulator output signal is not inverted; idle low output

**Bit 0 – BIT** Modulation Source Select Input bit  
 Allows software to manually set modulation source input to module

**Note:**

1. The modulated output frequency can be greater and asynchronous from the clock that updates this register bit, the bit value may not be valid for higher speed modulator or carrier signals.
2. MDBIT must be selected as the modulation source in the MDxSRC register for this operation.

### 32.12.2 MDxCON1

**Name:** MDxCON1  
**Address:** 0x0898

Modulation Control Register 1

Bit	7	6	5	4	3	2	1	0
			CHPOL	CHSYNC			CLPOL	CLSYNC
Access			R/W	R/W			R/W	R/W
Reset			0	0			0	0

**Bit 5 – CHPOL** Modulator High Carrier Polarity Select bit

Value	Description
1	Selected high carrier signal is inverted
0	Selected high carrier signal is not inverted

**Bit 4 – CHSYNC** Modulator High Carrier Synchronization Enable bit

Value	Description
1	Modulator waits for a falling edge on the high time carrier signal before allowing a switch to the low time carrier
0	Modulator output is not synchronized to the high time carrier signal

**Bit 1 – CLPOL** Modulator Low Carrier Polarity Select bit

Value	Description
1	Selected low carrier signal is inverted
0	Selected low carrier signal is not inverted

**Bit 0 – CLSYNC** Modulator Low Carrier Synchronization Enable bit

Value	Description
1	Modulator waits for a falling edge on the low time carrier signal before allowing a switch to the high time carrier
0	Modulator output is not synchronized to the low time carrier signal

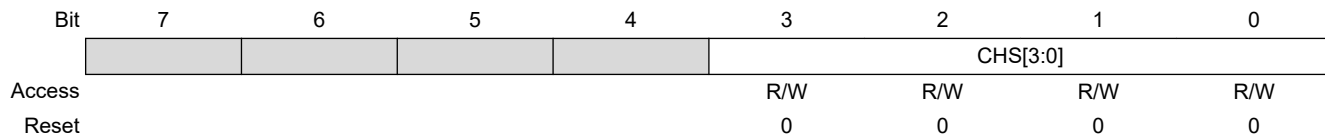
**Note:**

1. Narrowed carrier pulse widths or spurs may occur in the signal stream if the carrier is not synchronized.

**32.12.3 MDxCARH**

**Name:** MDxCARH  
**Address:** 0x089B

Modulation High Carrier Control Register



**Bits 3:0 – CHS[3:0]** Modulator Carrier High Selection bits

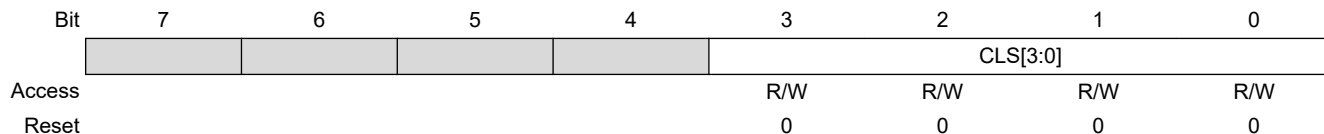
**Table 32-5. MDCARH Source Selections**

MDCARH	
CHS<3:0>	Connection
1111	CCP5 OUT
1110	CLC4 OUT
1101	CLC3 OUT
1100	CLC2 OUT
1011	CLC1 OUT
1010	NCO1 OUT
1001	PWM7 OUT
1000	PWM6 OUT
0111	CCP4 OUT
0110	CCP3 OUT
0101	CCP2 OUT
0100	CCP1 OUT
0011	CLKREF output
0010	HFINTOSC
0001	F <sub>OSC</sub> (system clock)
0000	Pin selected by MDCARHPPS

**32.12.4 MDxCARL**

**Name:** MDxCARL  
**Address:** 0x089A

Modulation Low Carrier Control Register



**Bits 3:0 – CLS[3:0]** Modulator Carrier Low Input Selection bits

**Table 32-6. MDCARL Source Selections**

MDCARL	
CLS<3:0>	Connection
1111	CCP5 OUT
1110	CLC4 OUT
1101	CLC3 OUT
1100	CLC2 OUT
1011	CLC1 OUT
1010	NCO1 OUT
1001	PWM7 OUT
1000	PWM6 OUT
0111	CCP4 OUT
0110	CCP3 OUT
0101	CCP2 OUT
0100	CCP1 OUT
0011	CLKREF output
0010	HFINTOSC
0001	F <sub>OSC</sub> (system clock)
0000	Pin selected by MDCARLPPS

### 32.12.5 MDxSRC

**Name:** MDxSRC  
**Address:** 0x0899

Modulation Source Control Register

	7	6	5	4	3	2	1	0
	SRCS[4:0]							
Access				R/W	R/W	R/W	R/W	R/W
Reset				0	0	0	0	0

**Bits 4:0 – SRCS[4:0]** Modulator Source Selection bits

**Table 32-7. MDSRC Selection MUX Connections**

SRCS<4:0>	Connection
11111-10100	Reserved
10011	EUSART2 TX (TX/CK output)
10010	CCP5 OUT
10001	MSSP2 - SDO
10000	MSSP1 - SDO
01111	EUSART1 TX (TX/CK output)
01110	CLC4 OUT
01101	CLC3 OUT
01100	CLC2 OUT
01011	CLC1 OUT
01010	C2 OUT
01001	C1 OUT
01000	NCO1 OUT
00111	PWM7 OUT
00110	PWM6 OUT
00101	CCP4 OUT
00100	CCP3 OUT
00011	CCP2 OUT
00010	CCP1 OUT
00001	MDBIT
00000	Pin selected by MDSRCPPS

### 33. (CLC) Configurable Logic Cell

The Configurable Logic Cell (CLCx) module provides programmable logic that operates outside the speed limitations of software execution. The logic cell takes up to 64 input signals and, through the use of configurable gates, reduces the 64 inputs to four logic lines that drive one of eight selectable single-output logic functions.

Input sources are a combination of the following:

- I/O pins
- Internal clocks
- Peripherals
- Register bits

The output can be directed internally to peripherals and to an output pin.



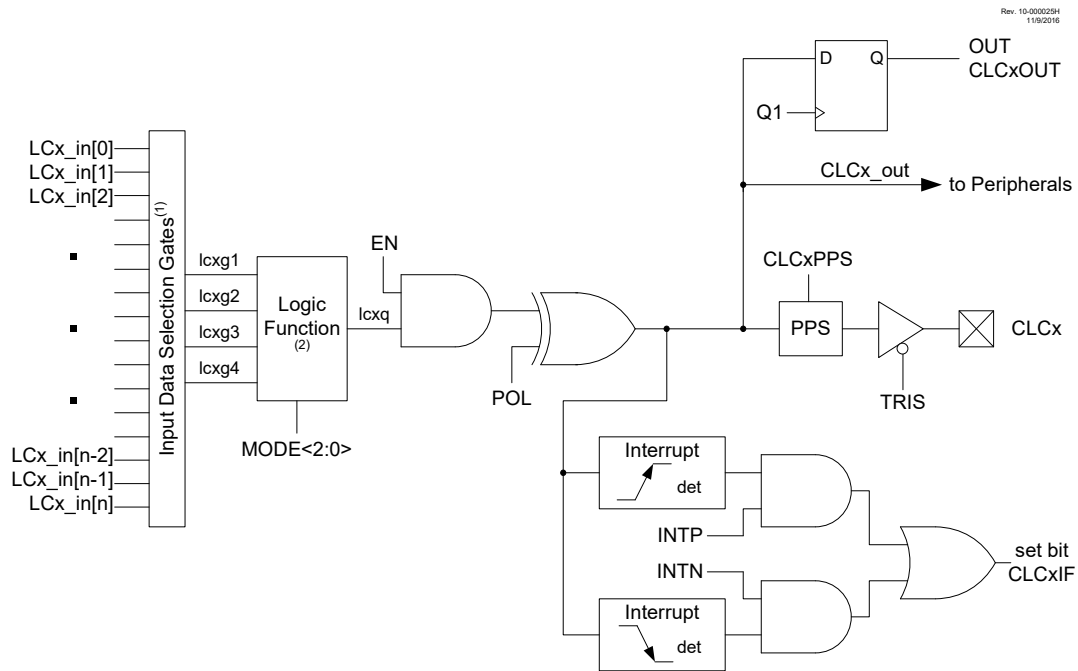
**Important:** There are several CLC instances on this device. Throughout this section, the lower case 'x' in register names is a generic reference to the CLC instance number. For example, the first instance of the control register is CLC1CON and is generically described in this chapter as CLCxCON.

The following figure is a simplified diagram showing signal flow through the CLC. Possible configurations include:

- Combinatorial Logic
  - AND
  - NAND
  - AND-OR
  - AND-OR-INVERT
  - OR-XOR
  - OR-XNOR
- Latches
  - S-R
  - Clocked D with Set and Reset
  - Transparent D with Set and Reset



**Figure 33-1. CLC Simplified Block Diagram**



**Note:**

1. See [Figure 33-2](#) for input data selection and gating.
2. See [Figure 33-3](#) for programmable logic functions.

### 33.1 CLC Setup

Programming the CLC module is performed by configuring the four stages in the logic signal flow. The four stages are:

- Data selection
- Data gating
- Logic function selection
- Output polarity

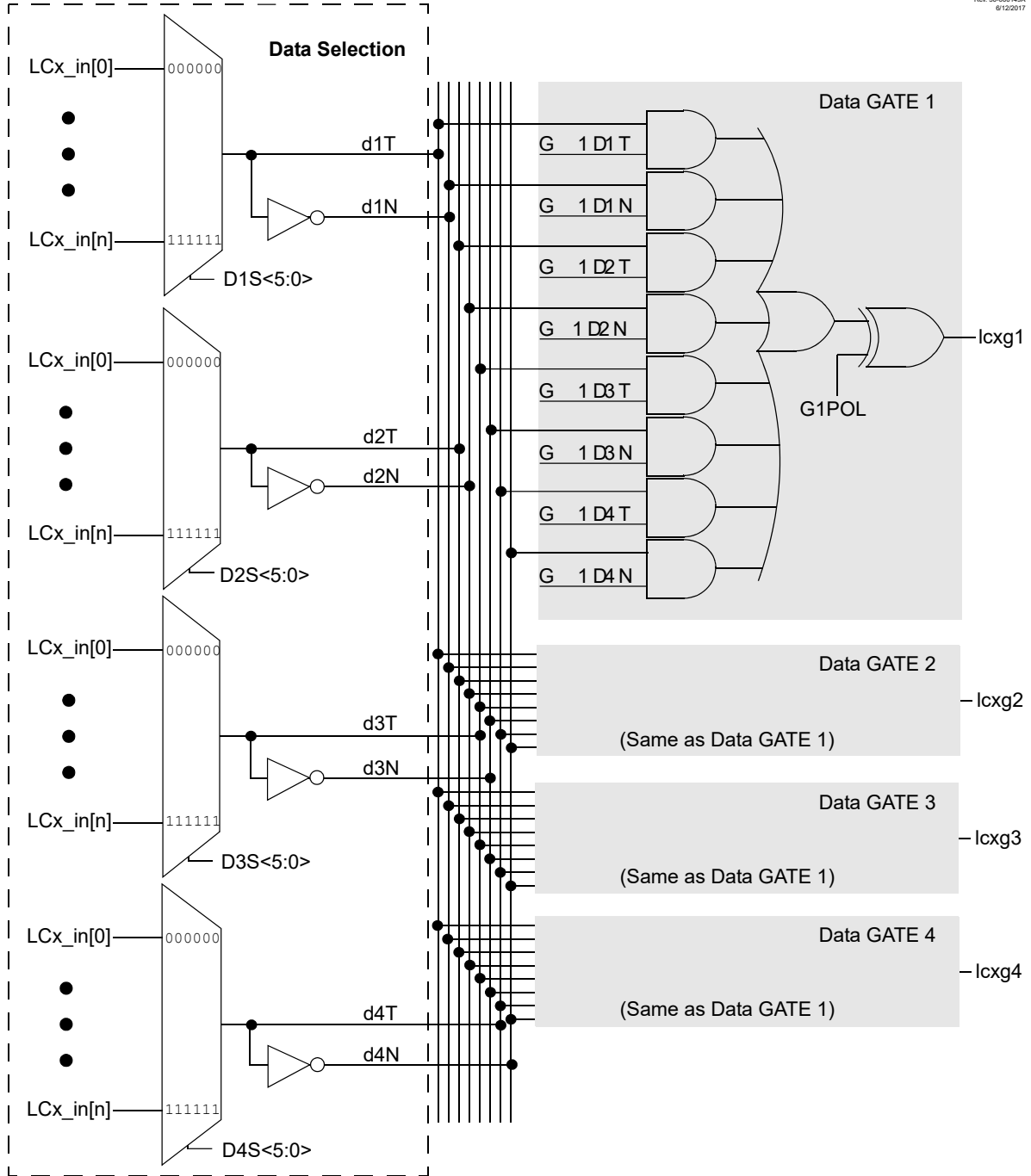
Each stage is setup at run time by writing to the corresponding CLC Special Function Registers. This has the added advantage of permitting logic reconfiguration on-the-fly during program execution.

#### 33.1.1 Data Selection

There are 64 signals available as inputs to the configurable logic. Four 64-input multiplexers are used to select the inputs to pass on to the next stage.

Data selection is through four multiplexers as indicated on the left side of the following diagram. Data inputs in the figure are identified by a generic numbered input name.

Figure 33-2. Input Data Selection and Gating



**Note:** All controls are undefined at power-up.

The following table correlates the generic input name to the actual signal for each CLC module. The column labeled 'DyS Value' indicates the MUX selection code for the selected data input. DyS is an abbreviation for the MUX select input codes: D1S through D4S where 'y' is the gate number.

# PIC16(L)F18455/56

## (CLC) Configurable Logic Cell

### CLC Data Input Sources

DyS Value	CLC Input Source	DyS Value	CLC Input Source
111111 [63]	Reserved	011111 [31]	DSM1_out
111110 [62]	Reserved	011110 [30]	IOC_flag
111101 [61]	Reserved	011101 [29]	ZCD_out
111100 [60]	Reserved	011100 [28]	C2_out
111011 [59]	Reserved	011011 [27]	C1_out
111010 [58]	Reserved	011010 [26]	NCO1_out
111001 [57]	Reserved	011001 [25]	PWM7_out
111000 [56]	Reserved	011000 [24]	PWM6_out
110111 [55]	Reserved	010111 [23]	CCP4_out
110110 [54]	Reserved	010110 [22]	CCP3_out
110101 [53]	Reserved	010101 [21]	CCP2_out
110100 [52]	Reserved	010100 [20]	CCP1_out
110011 [51]	EUSART2_CK_out	010011 [19]	SMT1_overflow
110010 [50]	EUSART2_DT_out	010010 [18]	TMR6_out
110001 [49]	CCP5_out	010001 [17]	TMR5_overflow
110000 [48]	SMT2_overflow	010000 [16]	TMR4_out
101111 [47]	CWG3B_out	001111 [15]	TMR3_overflow
101110 [46]	CWG3A_out	001110 [14]	TMR2_out
101101 [45]	CWG2B_out	001101 [13]	TMR1_overflow
101100 [44]	CWG2A_out	001100 [12]	TMR0_overflow
101011 [43]	CWG1B_out	001011 [11]	CLKR_out
101010 [42]	CWG1A_out	001010 [10]	FRC
101001 [41]	MSSP2_clk_out	001001 [9]	SOSC
101000 [40]	MSSP2_data_out	001000 [8]	MFINTOSC (32 kHz)
100111 [39]	MSSP1_clk_out	000111 [7]	MFINTOSC (500 kHz)
100110 [38]	MSSP1_data_out	000110 [6]	LFINTOSC
100101 [37]	EUSART1_CK_out	000101 [5]	HFINTOSC (32 MHz)
100100 [36]	EUSART1_DT_out	000100 [4]	F <sub>osc</sub>
100011 [35]	CLC4_out	000011 [3]	CLCIN3PPS
100010 [34]	CLC3_out	000010 [2]	CLCIN2PPS

DyS Value	CLC Input Source	DyS Value	CLC Input Source
100001 [33]	CLC2_out	000001 [1]	CLCIN1PPS
100000 [32]	CLC1_out	000000 [0]	CLCIN0PPS

Data inputs are selected with CLCxSEL0 through CLCxSEL3 registers.



**Important:** Data selections are undefined at power-up.

### 33.1.2 Data Gating

Outputs from the input multiplexers are directed to the desired logic function input through the data gating stage. Each data gate can direct any combination of the four selected inputs.

The gate stage is more than just signal direction. The gate can be configured to direct each input signal as inverted or non-inverted data. Directed signals are ANDed together in each gate. The output of each gate can be inverted before going on to the logic function stage.

The gating is in essence a 1-to-4 input AND/NAND/OR/NOR gate. When every input is inverted and the output is inverted, the gate is an AND of all enabled data inputs. When the inputs and output are not inverted, the gate is an OR of all enabled inputs.

The following table summarizes the basic logic that can be obtained in gate 1 by using the gate logic select bits. The table shows the logic of four input variables, but each gate can be configured to use less than four. If no inputs are selected, the output will be zero or one, depending on the gate output polarity bit.

**Table 33-1. Data Gating Logic**

CLCxGLSy	GyPOL	Gate Logic
0x55	1	AND
0x55	0	NAND
0xAA	1	NOR
0xAA	0	OR
0x00	0	Logic 0
0x00	1	Logic 1

It is possible (but not recommended) to select both the true and negated values of an input. When this is done, the gate output is zero, regardless of the other inputs, but may emit logic glitches (transient-induced pulses). If the output of the channel must be zero or one, the recommended method is to set all gate bits to zero and use the gate polarity bit to set the desired level.

Data gating is configured with the logic gate select registers as follows:

- Gate 1: [CLCxSEL0](#)
- Gate 2: [CLCxSEL1](#)
- Gate 3: [CLCxSEL2](#)

- Gate 4: [CLCxSEL3](#)

Register number suffixes are different than the gate numbers because other variations of this module have multiple gate selections in the same register.

Data gating is indicated in the right side of [Figure 33-2](#). Only one gate is shown in detail. The remaining three gates are configured identically with the exception that the data enables correspond to the enables for that gate.

### 33.1.3 Logic Function

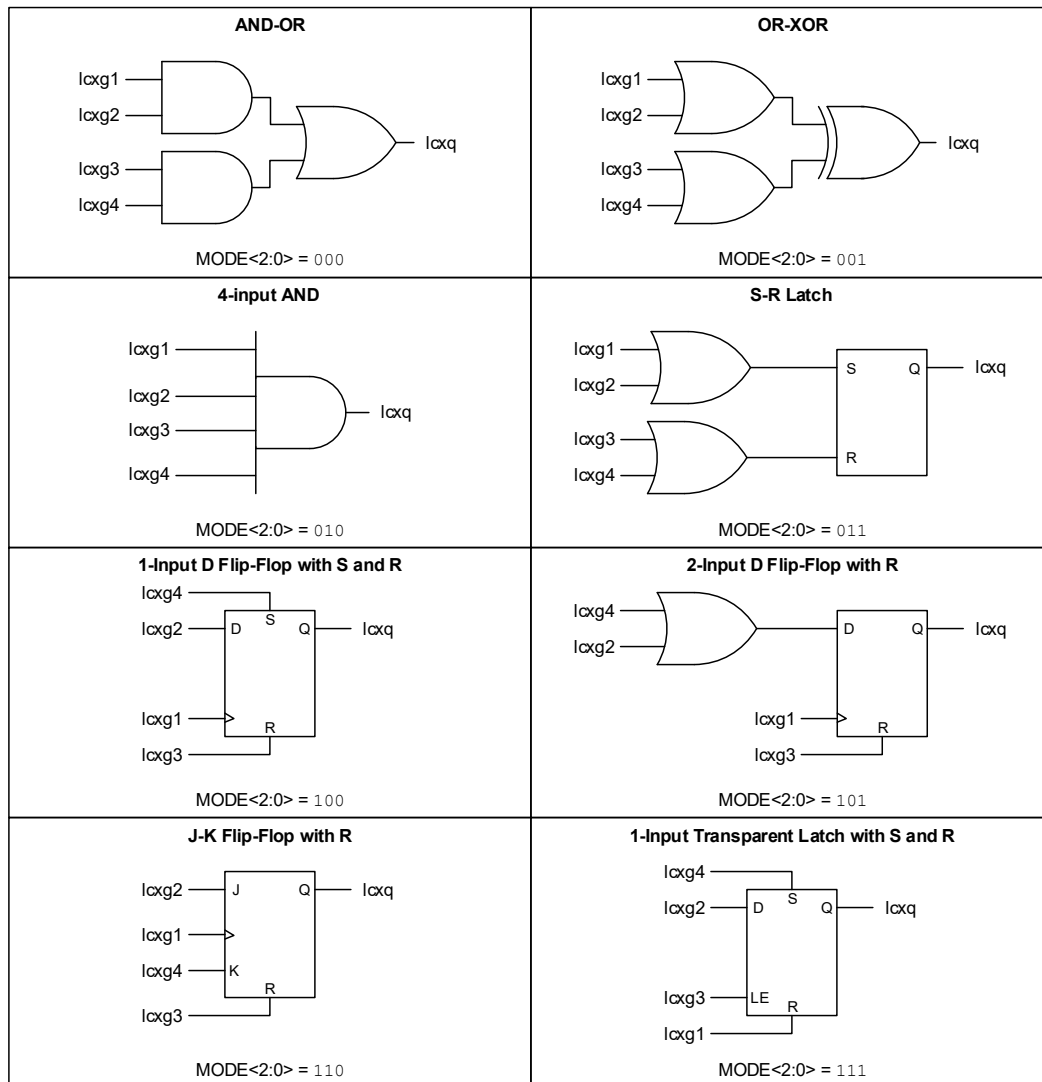
There are eight available logic functions including:

- AND-OR
- OR-XOR
- AND
- S-R Latch
- D Flip-Flop with Set and Reset
- D Flip-Flop with Reset
- J-K Flip-Flop with Reset
- Transparent Latch with Set and Reset

Logic functions are shown in the following diagram. Each logic function has four inputs and one output. The four inputs are the four data gate outputs of the previous stage. The output is fed to the inversion stage and from there to other peripherals, an output pin, and back to the CLC itself.

**Figure 33-3. Programmable Logic Functions**

Rev: 10-000122B  
9/13/2016



### 33.1.4 Output Polarity

The last stage in the Configurable Logic Cell is the output polarity. Setting the **POL** bit inverts the output signal from the logic stage. Changing the polarity while the interrupts are enabled will cause an interrupt for the resulting output transition.

## 33.2 CLC Interrupts

An interrupt will be generated upon a change in the output value of the CLCx when the appropriate interrupt enables are set. A rising edge detector and a falling edge detector are present in each CLC for this purpose.

The CLCxIF bit of the associated PIR register will be set when either edge detector is triggered and its associated enable bit is set. The [INTP](#) enables rising edge interrupts and the [INTN](#) bit enables falling edge interrupts.

To fully enable the interrupt, set the following bits:

- CLCxIE bit of the respective PIE register
- [INTP](#) bit (for a rising edge detection)
- [INTN](#) bit (for a falling edge detection)
- If priority interrupts are not used
  - Clear the IPEN bit of the INTCON register
  - Set the GIE bit of the INTCON register
  - Set the PEIE bit of the INTCON register
- If the CLC is a high priority interrupt
  - Set the IPEN bit of the INTCON register
  - Set the CLCxIP bit of the respective IPR register
  - Set the GIEH bit of the INTCON register
- If the CLC is a low priority interrupt
  - Set the IPEN bit of the INTCON register
  - Clear the CLCxIP bit of the respective IPR register
  - Set the GIEL bit of the INTCON register

The CLCxIF bit of the respective PIR register, must be cleared in software as part of the interrupt service. If another edge is detected while this flag is being cleared, the flag will still be set at the end of the sequence.

#### **Related Links**

[7.8.10 INTCON](#)

[10.7.7 PIE5](#)

[10.7.16 PIR5](#)

### **33.3 Output Mirror Copies**

Mirror copies of all CLCxOUT bits are contained in the [33.8.11 CLCDATA](#) register. Reading this register reads the outputs of all CLCs simultaneously. This prevents any reading skew introduced by testing or reading the OUT bits in the individual CLCxCON registers.

### **33.4 Effects of a Reset**

The CLCxCON register is cleared to zero as the result of a Reset. All other selection and gating values remain unchanged.

### **33.5 Operation During Sleep**

The CLC module operates independently from the system clock and will continue to run during Sleep, provided that the input sources selected remain active.

The HFINTOSC remains active during Sleep when the CLC module is enabled and the HFINTOSC is selected as an input source, regardless of the system clock source selected.

In other words, if the HFINTOSC is simultaneously selected as the system clock and as a CLC input source, when the CLC is enabled, the CPU will go idle during Sleep, but the CLC will continue to operate and the HFINTOSC will remain active.

This will have a direct effect on the Sleep mode current.

### **33.6 CLC Setup Steps**

The following steps should be followed when setting up the CLC:

- Disable CLC by clearing the [EN](#) bit.
- Select desired inputs using the [CLCxSEL0](#) through [CLCxSEL3](#) registers (See [CLC Data Input Table](#)).
- Clear any associated ANSEL bits.
- Set all TRIS bits associated with inputs.
- Enable the chosen inputs through the four gates using the [CLCxGLS0](#) through [CLCxGLS3](#) registers.
- Select the gate output polarities with the [GyPOL](#) bits
- Select the desired logic function with the [MODE](#) bits
- Select the desired polarity of the logic output with the [POL](#) bit. (This step may be combined with the previous gate output polarity step).
- If driving a device pin, set the desired pin PPS control register and also clear the TRIS bit corresponding to that output.
- Configure the interrupts (optional). See [33.2 CLC Interrupts](#)
- Enable the CLC by setting the [EN](#) bit.



### 33.7 Register Summary - CLC Control

Address	Name	Bit Pos.									
0x1E0F	CLCDATA	7:0						MLC4OUT	MLC3OUT	MLC2OUT	MLC1OUT
0x1E10	CLC1CON	7:0	EN		OUT	INTP	INTN	MODE[2:0]			
0x1E11	CLC1POL	7:0	POL				G4POL	G3POL	G2POL	G1POL	
0x1E12	CLC1SEL0	7:0					D1S[5:0]				
0x1E13	CLC1SEL1	7:0					D2S[5:0]				
0x1E14	CLC1SEL2	7:0					D3S[5:0]				
0x1E15	CLC1SEL3	7:0					D4S[5:0]				
0x1E16	CLC1GLS0	7:0	G1D4T	G1D4N	G1D3T	G1D3N	G1D2T	G1D2N	G1D1T	G1D1N	
0x1E17	CLC1GLS1	7:0	G2D4T	G2D4N	G2D3T	G2D3N	G2D2T	G2D2N	G2D1T	G2D1N	
0x1E18	CLC1GLS2	7:0	G3D4T	G3D4N	G3D3T	G3D3N	G3D2T	G3D2N	G3D1T	G3D1N	
0x1E19	CLC1GLS3	7:0	G4D4T	G4D4N	G4D3T	G4D3N	G4D2T	G4D2N	G4D1T	G4D1N	
0x1E1A	CLC2CON	7:0	EN		OUT	INTP	INTN	MODE[2:0]			
0x1E1B	CLC2POL	7:0	POL				G4POL	G3POL	G2POL	G1POL	
0x1E1C	CLC2SEL0	7:0					D1S[5:0]				
0x1E1D	CLC2SEL1	7:0					D2S[5:0]				
0x1E1E	CLC2SEL2	7:0					D3S[5:0]				
0x1E1F	CLC2SEL3	7:0					D4S[5:0]				
0x1E20	CLC2GLS0	7:0	G1D4T	G1D4N	G1D3T	G1D3N	G1D2T	G1D2N	G1D1T	G1D1N	
0x1E21	CLC2GLS1	7:0	G2D4T	G2D4N	G2D3T	G2D3N	G2D2T	G2D2N	G2D1T	G2D1N	
0x1E22	CLC2GLS2	7:0	G3D4T	G3D4N	G3D3T	G3D3N	G3D2T	G3D2N	G3D1T	G3D1N	
0x1E23	CLC2GLS3	7:0	G4D4T	G4D4N	G4D3T	G4D3N	G4D2T	G4D2N	G4D1T	G4D1N	
0x1E24	CLC3CON	7:0	EN		OUT	INTP	INTN	MODE[2:0]			
0x1E25	CLC3POL	7:0	POL				G4POL	G3POL	G2POL	G1POL	
0x1E26	CLC3SEL0	7:0					D1S[5:0]				
0x1E27	CLC3SEL1	7:0					D2S[5:0]				
0x1E28	CLC3SEL2	7:0					D3S[5:0]				
0x1E29	CLC3SEL3	7:0					D4S[5:0]				
0x1E2A	CLC3GLS0	7:0	G1D4T	G1D4N	G1D3T	G1D3N	G1D2T	G1D2N	G1D1T	G1D1N	
0x1E2B	CLC3GLS1	7:0	G2D4T	G2D4N	G2D3T	G2D3N	G2D2T	G2D2N	G2D1T	G2D1N	
0x1E2C	CLC3GLS2	7:0	G3D4T	G3D4N	G3D3T	G3D3N	G3D2T	G3D2N	G3D1T	G3D1N	
0x1E2D	CLC3GLS3	7:0	G4D4T	G4D4N	G4D3T	G4D3N	G4D2T	G4D2N	G4D1T	G4D1N	
0x1E2E	CLC4CON	7:0	EN		OUT	INTP	INTN	MODE[2:0]			
0x1E2F	CLC4POL	7:0	POL				G4POL	G3POL	G2POL	G1POL	
0x1E30	CLC4SEL0	7:0					D1S[5:0]				
0x1E31	CLC4SEL1	7:0					D2S[5:0]				
0x1E32	CLC4SEL2	7:0					D3S[5:0]				
0x1E33	CLC4SEL3	7:0					D4S[5:0]				
0x1E34	CLC4GLS0	7:0	G1D4T	G1D4N	G1D3T	G1D3N	G1D2T	G1D2N	G1D1T	G1D1N	
0x1E35	CLC4GLS1	7:0	G2D4T	G2D4N	G2D3T	G2D3N	G2D2T	G2D2N	G2D1T	G2D1N	
0x1E36	CLC4GLS2	7:0	G3D4T	G3D4N	G3D3T	G3D3N	G3D2T	G3D2N	G3D1T	G3D1N	
0x1E37	CLC4GLS3	7:0	G4D4T	G4D4N	G4D3T	G4D3N	G4D2T	G4D2N	G4D1T	G4D1N	

### 33.8 Register Definitions: Configurable Logic Cell

Long bit name prefixes for the CLC peripherals are shown in the table below. Refer to the *"Long Bit Names Section"* for more information.

**Table 33-2. CLC Bit Name Prefixes**

Peripheral	Bit Name Prefix
CLC1	LC1
CLC2	LC2
CLC3	LC3
CLC4	LC4

#### Related Links

[1.4.2.2 Long Bit Names](#)

### 33.8.1 CLCxCON

**Name:** CLCxCON  
**Address:** 0x1E10,0x1E1A,0x1E24,0x1E2E

Configurable Logic Cell Control Register

Bit	7	6	5	4	3	2	1	0
	EN		OUT	INTP	INTN	MODE[2:0]		
Access	R/W		RO	R/W	R/W	R/W	R/W	R/W
Reset	0		0	0	0	0	0	0

#### Bit 7 – EN

CLC Enable bit

Value	Description
1	Configurable logic cell is enabled and mixing signals
0	Configurable logic cell is disabled and has logic zero output

#### Bit 5 – OUT

Logic cell output data, after LCPOL. Sampled from CLCxOUT

#### Bit 4 – INTP

Configurable Logic Cell Positive Edge Going Interrupt Enable bit

Value	Description
1	CLCxIF will be set when a rising edge occurs on CLCxOUT
0	Rising edges on CLCxOUT have no effect on CLCxIF

#### Bit 3 – INTN

Configurable Logic Cell Negative Edge Going Interrupt Enable bit

Value	Description
1	CLCxIF will be set when a falling edge occurs on CLCxOUT
0	Falling edges on CLCxOUT have no effect on CLCxIF

#### Bits 2:0 – MODE[2:0]

Configurable Logic Cell Functional Mode Selection bits

Value	Description
111	Cell is 1-input transparent latch with Set and Reset
110	Cell is J-K flip-flop with Reset
101	Cell is 2-input D flip-flop with Reset
100	Cell is 1-input D flip-flop with Set and Reset
011	Cell is S-R latch
010	Cell is 4-input AND
001	Cell is OR-XOR
000	Cell is AND-OR

**33.8.2 CLCxPOL**

**Name:** CLCxPOL  
**Address:** 0x1E11,0x1E1B,0x1E25,0x1E2F

Signal Polarity Control Register

Bit	7	6	5	4	3	2	1	0
	POL				G4POL	G3POL	G2POL	G1POL
Access	R/W				R/W	R/W	R/W	R/W
Reset	0				x	x	x	x

**Bit 7 – POL**

CLCxOUT Output Polarity Control bit

Value	Description
1	The output of the logic cell is inverted
0	The output of the logic cell is not inverted

**Bits 0, 1, 2, 3 – GyPOL**

Gate Output Polarity Control bit

Reset States: Default = xxxx  
 POR/BOR = x  
 All Other Resets = u

Value	Description
1	The gate output is inverted when applied to the logic cell
0	The output of the gate is not inverted

**33.8.3 CLCxSELO**

**Name:** CLCxSELO  
**Address:** 0x1E12,0x1E1C,0x1E26,0x1E30

Generic CLCx Data 1 Select Register

Bit	7	6	5	4	3	2	1	0
			D1S[5:0]					
Access			R/W	R/W	R/W	R/W	R/W	R/W
Reset			x	x	x	x	x	x

**Bits 5:0 – D1S[5:0]**

CLCx Data1 Input Selection bits

Reset States: POR/BOR = xxxxxx

All Other Resets = uuuuuu

Value	Description
n	Refer to <a href="#">CLC Input Sources</a> for input selections

**33.8.4 CLCxSEL1**

**Name:** CLCxSEL1  
**Address:** 0x1E13,0x1E1D,0x1E27,0x1E31

Generic CLCx Data 1 Select Register

Bit	7	6	5	4	3	2	1	0
			D2S[5:0]					
Access			R/W	R/W	R/W	R/W	R/W	R/W
Reset			x	x	x	x	x	x

**Bits 5:0 – D2S[5:0]**

CLCx Data2 Input Selection bits

Reset States: POR/BOR = xxxxxx

All Other Resets = uuuuuu

Value	Description
n	Refer to <a href="#">CLC Input Sources</a> for input selections

**33.8.5 CLCxSEL2**

**Name:** CLCxSEL2  
**Address:** 0x1E14,0x1E1E,0x1E28,0x1E32

Generic CLCx Data 1 Select Register

Bit	7	6	5	4	3	2	1	0
			D3S[5:0]					
Access			R/W	R/W	R/W	R/W	R/W	R/W
Reset			x	x	x	x	x	x

**Bits 5:0 – D3S[5:0]**

CLCx Data3 Input Selection bits

Reset States: POR/BOR = xxxxxx

All Other Resets = uuuuuu

Value	Description
n	Refer to <a href="#">CLC Input Sources</a> for input selections

**33.8.6 CLCxSEL3**

**Name:** CLCxSEL3  
**Address:** 0x1E15,0x1E1F,0x1E29,0x1E33

Generic CLCx Data 4 Select Register

Bit	7	6	5	4	3	2	1	0
			D4S[5:0]					
Access			R/W	R/W	R/W	R/W	R/W	R/W
Reset			x	x	x	x	x	x

**Bits 5:0 – D4S[5:0]**

CLCx Data4 Input Selection bits

Reset States: POR/BOR = xxxxxx

All Other Resets = uuuuuu

Value	Description
n	Refer to <a href="#">CLC Input Sources</a> for input selections



**33.8.7 CLCxGLS0**

**Name:** CLCxGLS0  
**Address:** 0x1E16,0x1E20,0x1E2A,0x1E34

CLCx Gate1 Logic Select Register

Bit	7	6	5	4	3	2	1	0
	G1D4T	G1D4N	G1D3T	G1D3N	G1D2T	G1D2N	G1D1T	G1D1N
Access	R/W	R/W	R/W	R/W	R/W	R/W	R/W	R/W
Reset	x	x	x	x	x	x	x	x

**Bits 1, 3, 5, 7 – G1DyT**

dyT: Gate1 Data 'y' True (non-inverted) bit

Reset States: Default = xxxx  
 POR/BOR = x  
 All Other Resets = u

Value	Description
1	dyT is gated into g1
0	dyT is not gated into g1

**Bits 0, 2, 4, 6 – G1DyN**

dyN: Gate1 Data 'y' Negated (inverted) bit

Reset States: Default = xxxx  
 POR/BOR = x  
 All Other Resets = u

Value	Description
1	dyN is gated into g1
0	dyN is not gated into g1

**33.8.8 CLCxGLS1**

**Name:** CLCxGLS1  
**Address:** 0x1E17,0x1E21,0x1E2B,0x1E35

CLCx Gate2 Logic Select Register

Bit	7	6	5	4	3	2	1	0
	G2D4T	G2D4N	G2D3T	G2D3N	G2D2T	G2D2N	G2D1T	G2D1N
Access	R/W	R/W	R/W	R/W	R/W	R/W	R/W	R/W
Reset	x	x	x	x	x	x	x	x

**Bits 1, 3, 5, 7 – G2DyT**

dyT: Gate2 Data 'y' True (non-inverted) bit

Reset States: Default = xxxx  
 POR/BOR = x  
 All Other Resets = u

Value	Description
1	dyT is gated into g2
0	dyT is not gated into g2

**Bits 0, 2, 4, 6 – G2DyN**

dyN: Gate2 Data 'y' Negated (inverted) bit

Reset States: Default = xxxx  
 POR/BOR = x  
 All Other Resets = u

Value	Description
1	dyN is gated into g2
0	dyN is not gated into g2

### 33.8.9 CLCxGLS2

**Name:** CLCxGLS2  
**Address:** 0x1E18,0x1E22,0x1E2C,0x1E36

CLCx Gate3 Logic Select Register

Bit	7	6	5	4	3	2	1	0
	G3D4T	G3D4N	G3D3T	G3D3N	G3D2T	G3D2N	G3D1T	G3D1N
Access	R/W	R/W	R/W	R/W	R/W	R/W	R/W	R/W
Reset	x	x	x	x	x	x	x	x

#### Bits 1, 3, 5, 7 – G3DyT

dyT: Gate3 Data 'y' True (non-inverted) bit

Reset States: Default = xxxx  
 POR/BOR = x  
 All Other Resets = u

Value	Description
1	dyT is gated into g3
0	dyT is not gated into g3

#### Bits 0, 2, 4, 6 – G3DyN

dyN: Gate3 Data 'y' Negated (inverted) bit

Reset States: Default = xxxx  
 POR/BOR = x  
 All Other Resets = u

Value	Description
1	dyN is gated into g3
0	dyN is not gated into g3

**33.8.10 CLCxGLS3**

**Name:** CLCxGLS3  
**Address:** 0x1E19,0x1E23,0x1E2D,0x1E37

CLCx Gate4 Logic Select Register

Bit	7	6	5	4	3	2	1	0
	G4D4T	G4D4N	G4D3T	G4D3N	G4D2T	G4D2N	G4D1T	G4D1N
Access	R/W	R/W	R/W	R/W	R/W	R/W	R/W	R/W
Reset	x	x	x	x	x	x	x	x

**Bits 1, 3, 5, 7 – G4DyT**

dyT: Gate4 Data 'y' True (non-inverted) bit

Reset States: Default = xxxx  
 POR/BOR = x  
 All Other Resets = u

Value	Description
1	dyT is gated into g4
0	dyT is not gated into g4

**Bits 0, 2, 4, 6 – G4DyN**

dyN: Gate4 Data 'y' Negated (inverted) bit

Reset States: Default = xxxx  
 POR/BOR = x  
 All Other Resets = u

Value	Description
1	dyN is gated into g4
0	dyN is not gated into g4

**33.8.11 CLCDATA**

**Name:** CLCDATA  
**Address:** 0x1E0F

CLC Data Output Register

Mirror copy of

	7	6	5	4	3	2	1	0
					MLC4OUT	MLC3OUT	MLC2OUT	MLC1OUT
Access					R/W	R/W	R/W	R/W
Reset					0	0	0	0

**Bits 0, 1, 2, 3 – MLCxOUT**

Mirror copy of CLCx\_out bit

Value	Description
1	CLCx_out is 1
0	CLCx_out is 0

### 34. Reference Clock Output Module

The reference clock output module provides the ability to send a clock signal to the clock reference output pin (CLKR). The reference clock output can also be routed internally as a signal for other peripherals, such as the Data Signal Modulator (DSM), Memory Scanner, and Timer module.

The reference clock output module has the following features:

- Selectable Clock Source Using the CLKRCLK Register
- Programmable Clock Divider
- Selectable Duty Cycle

Figure 34-1. Clock Reference Block Diagram

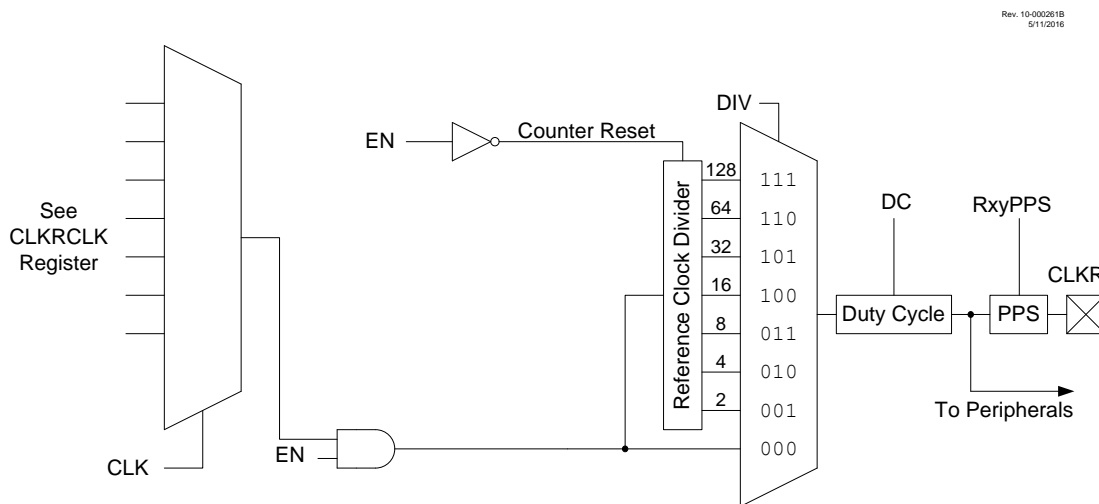
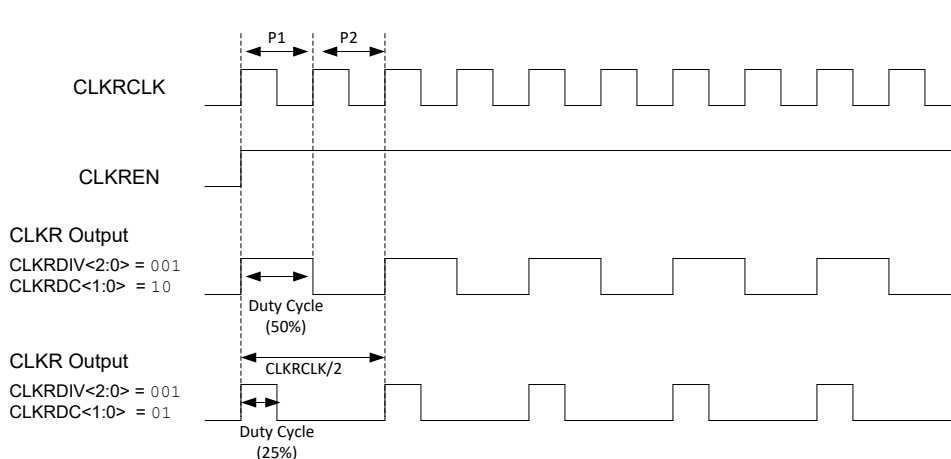


Figure 34-2. Clock Reference Timing



### 34.1 Clock Source

The clock source of the reference clock peripheral is selected with the **CLK** bits. The available clock sources are listed in the following table:

**Table 34-1. CLKR Clock Sources**

CLK	Clock Source
1111-1011	Reserved
1010	CLC4 OUT
1001	CLC3 OUT
1000	CLC2 OUT
0111	CLC1 OUT
0110	NCO1 OUT
0101	SOSC
0100	MFINTOSC (32 kHz)
0011	MFINTOSC (500 kHz)
0010	LFINTOSC
0001	HFINTOSC (32 MHz)
0000	F <sub>OSC</sub>

#### 34.1.1 Clock Synchronization

The CLKR output signal is ensured to be glitch-free when the **EN** bit is set to start the module and enable the CLKR output.

When the reference clock output is disabled, the output signal will be disabled immediately.

Clock dividers and clock duty cycles can be changed while the module is enabled but doing so may cause glitches to occur on the output. To avoid possible glitches, clock dividers and clock duty cycles should be changed only when the **EN** bit is clear.

### 34.2 Programmable Clock Divider

The module takes the clock input and divides it based on the value of the **DIV** bits.

The following configurations are available:

- Base F<sub>OSC</sub> value
- F<sub>OSC</sub> divided by 2
- F<sub>OSC</sub> divided by 4
- F<sub>OSC</sub> divided by 8
- F<sub>OSC</sub> divided by 16
- F<sub>OSC</sub> divided by 32
- F<sub>OSC</sub> divided by 64
- F<sub>OSC</sub> divided by 128

The clock divider values can be changed while the module is enabled. However, in order to prevent glitches on the output, the **DIV** bits should only be changed when the module is disabled (**EN** = 0).

### 34.3 Selectable Duty Cycle

The **DC** bits are used to modify the duty cycle of the output clock. A duty cycle of 0%, 25%, 50%, or 75% can be selected for all clock rates when the **DIV** value is not 0b000. When **DIV**=0b000 then the duty cycle defaults to 50% for all values of **DC** except 0b00 in which case the duty cycle is 0% (constant low output).

The duty cycle can be changed while the module is enabled. However, in order to prevent glitches on the output, the **DC** bits should only be changed when the module is disabled (**EN** = 0).



**Important:** The **DC** value at reset is 10. This makes the default duty cycle 50% and not 0%.

---

### 34.4 Operation in Sleep Mode

The reference clock module continues to operate and provide a signal output in Sleep for all clock source selections except  $F_{OSC}$  (**CLK**=0).



### 34.5 Register Summary: Reference CLK

Address	Name	Bit Pos.							
0x0895	<a href="#">CLKRCON</a>	7:0	EN			DC[1:0]		DIV[2:0]	
0x0896	<a href="#">CLKRCLK</a>	7:0						CLK[3:0]	

### 34.6 Register Definitions: Reference Clock

Long bit name prefixes for the Reference Clock peripherals are shown in the following table. Refer to the "Long Bit Names" section for more information.

**Table 34-2. TABLE 5-1:**

Peripheral	Bit Name Prefix
CLKR	CLKR

#### Related Links

[1.4.2.2 Long Bit Names](#)

### 34.6.1 CLKRCON

**Name:** CLKRCON  
**Address:** 0x895

Reference Clock Control Register

Bit	7	6	5	4	3	2	1	0
	EN			DC[1:0]		DIV[2:0]		
Access	R/W			R/W	R/W	R/W	R/W	R/W
Reset	0			1	0	0	0	0

#### Bit 7 – EN

Reference Clock Module Enable bit

Value	Description
1	Reference clock module enabled
0	Reference clock module is disabled

#### Bits 4:3 – DC[1:0]

Reference Clock Duty Cycle bits<sup>(1)</sup>

Value	Description
11	Clock outputs duty cycle of 75%
10	Clock outputs duty cycle of 50%
01	Clock outputs duty cycle of 25%
00	Clock outputs duty cycle of 0%

#### Bits 2:0 – DIV[2:0]

Reference Clock Divider bits

Value	Description
111	Base clock value divided by 128
110	Base clock value divided by 64
101	Base clock value divided by 32
100	Base clock value divided by 16
011	Base clock value divided by 8
010	Base clock value divided by 4
001	Base clock value divided by 2
000	Base clock value

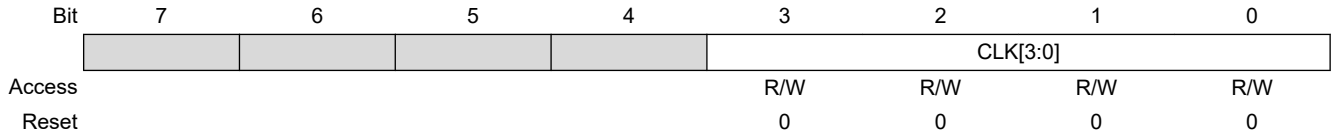
#### Note:

- Bits are valid for reference clock divider values of two or larger, the base clock cannot be further divided.

**34.6.2 CLKRCLK**

**Name:** CLKRCLK  
**Address:** 0x896

Clock Reference Clock Selection MUX



**Bits 3:0 – CLK[3:0]** CLKR Clock Selection bits  
 See the [Clock Sources](#) table.

## 35. (MSSP) Master Synchronous Serial Port Module

The Master Synchronous Serial Port (MSSP) module is a serial interface useful for communicating with other peripheral or microcontroller devices. These peripheral devices may be serial EEPROMs, shift registers, display drivers, A/D converters, etc. The MSSP module can operate in one of two modes:

- Serial Peripheral Interface (SPI)
- Inter-Integrated Circuit (I<sup>2</sup>C)

The SPI interface supports the following modes and features:

- Master mode
- Slave mode
- Clock Parity
- Slave Select Synchronization (Slave mode only)
- Daisy-chain connection of slave devices

The I<sup>2</sup>C interface supports the following modes and features:

- Master mode
- Slave mode
- Byte NACKing (Slave mode)
- Limited multi-master support
- 7-bit and 10-bit addressing
- Start and Stop interrupts
- Interrupt masking
- Clock stretching
- Bus collision detection
- General call address matching
- Address masking
- Address Hold and Data Hold modes
- Selectable SDA hold times

### 35.1 SPI Mode Overview

The Serial Peripheral Interface (SPI) bus is a synchronous serial data communication bus that operates in Full-Duplex mode. Devices communicate in a master/slave environment where the master device initiates the communication. A slave device is controlled through a Chip Select known as Slave Select.

The SPI bus specifies four signal connections:

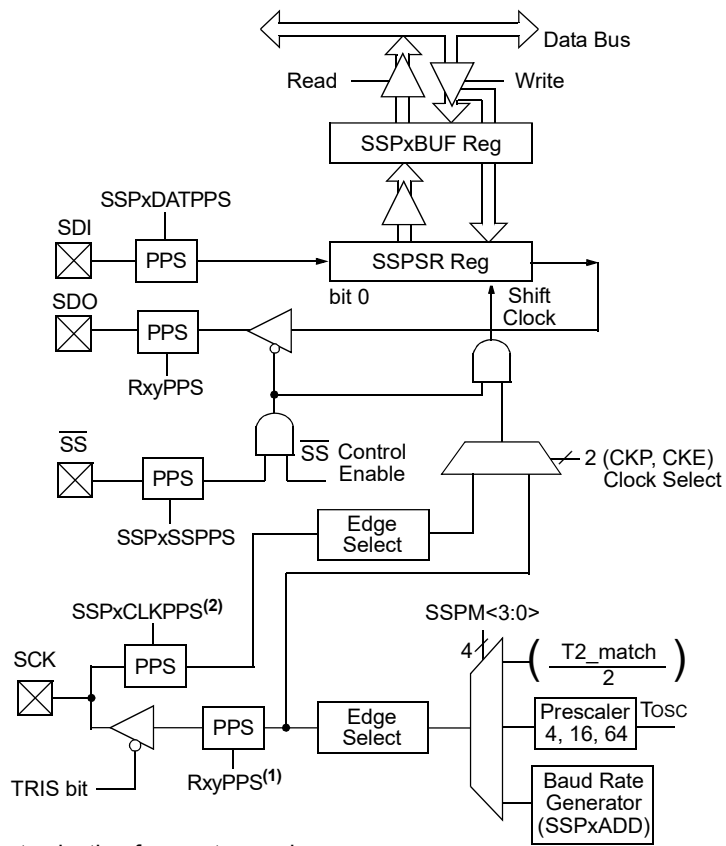
- Serial Clock (SCK)
- Serial Data Out (SDO)
- Serial Data In (SDI)
- Slave Select ( $\overline{SS}$ )

The following figure shows the block diagram of the MSSP module when operating in SPI mode.

# PIC16(L)F18455/56

## (MSSP) Master Synchronous Serial Port Module

**Figure 35-1. MSSP Block Diagram (SPI mode)**



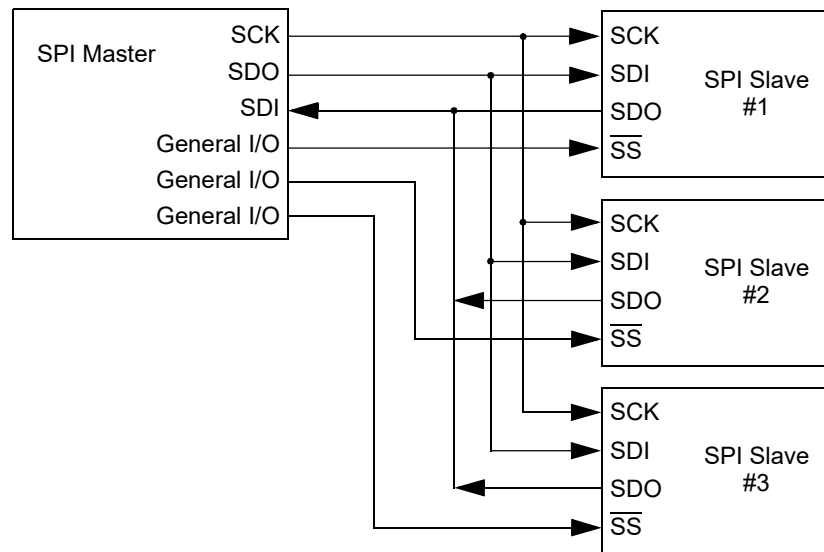
- Note 1:** Output selection for master mode  
**2:** Input selection for slave and master mode

The SPI bus operates with a single master device and one or more slave devices. When multiple slave devices are used, an independent Slave Select connection is required from the master device to each slave device.

The figure below shows a typical connection between a master device and multiple slave devices.

The master selects only one slave at a time. Most slave devices have tri-state outputs so their output signal appears disconnected from the bus when they are not selected.

**Figure 35-2. SPI Master and Multiple Slave Connection**



### 35.1.1 SPI Mode Registers

The MSSP module has five registers for SPI mode operation. These are:

- MSSP STATUS register (SSPxSTAT)
- MSSP Control register 1 (SSPxCON1)
- MSSP Control register 3 (SSPxCON3)
- MSSP Data Buffer register (SSPxBUF)
- MSSP Address register (SSPxADD)
- MSSP Shift register (SSPSR)  
(Not directly accessible)

SSPxCON1 and SSPxSTAT are the control and STATUS registers for SPI mode operation. The SSPxCON1 register is readable and writable. The lower six bits of the SSPxSTAT are read-only. The upper two bits of the SSPxSTAT are read/write.

One of the five SPI master modes uses the SSPxADD value to determine the Baud Rate Generator clock frequency. More information on the Baud Rate Generator is available in [35.7 Baud Rate Generator](#).

SSPSR is the shift register used for shifting data in and out. SSPxBUF provides indirect access to the SSPSR register. SSPxBUF is the buffer register to which data bytes are written, and from which data bytes are read.

In receive operations, SSPSR and SSPxBUF together create a buffered receiver. When SSPSR receives a complete byte, it is transferred to SSPxBUF and the SSPxIF interrupt is set.

During transmission, the SSPxBUF is not buffered. A write to SSPxBUF will write to both SSPxBUF and SSPSR.

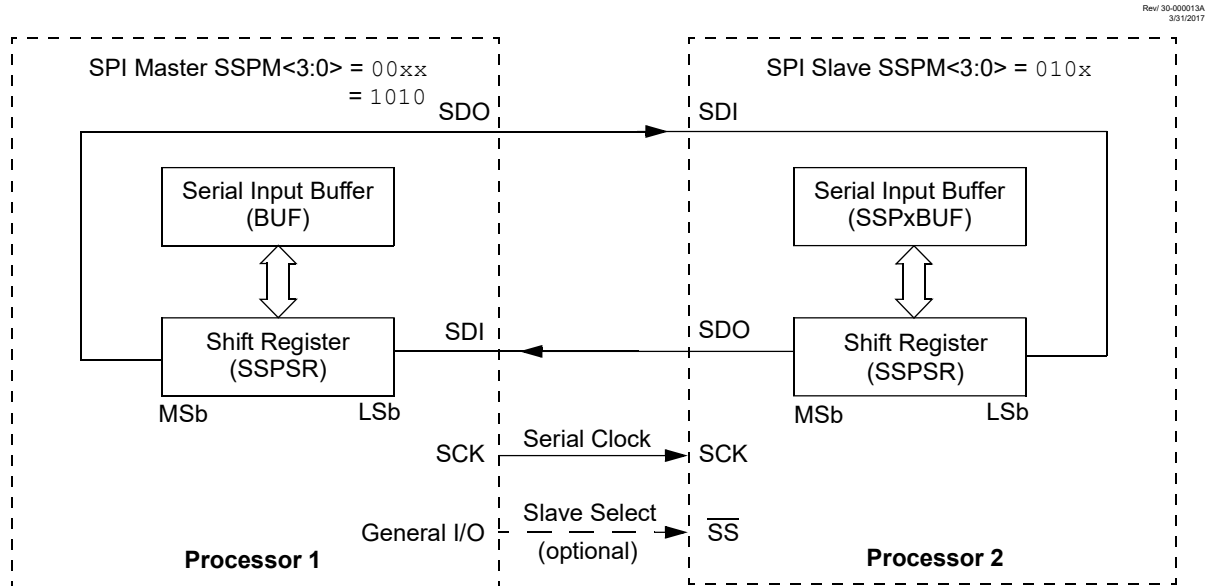
## 35.2 SPI Mode Operation

Transmissions involve two shift registers, eight bits in size, one in the master and one in the slave. With either the master or the slave device, data is always shifted out one bit at a time, with the Most Significant

bit (MSb) shifted out first. At the same time, a new Least Significant bit (LSb) is shifted into the same register.

The following figure shows a typical connection between two processors configured as master and slave devices.

**Figure 35-3. SPI Master/Slave Connection**



Data is shifted out of both shift registers on the programmed clock edge and latched on the opposite edge of the clock.

The master device transmits information out on its SDO output pin which is connected to, and received by, the slave's SDI input pin. The slave device transmits information out on its SDO output pin, which is connected to, and received by, the master's SDI input pin.

To begin communication, the master device first sends out the clock signal. Both the master and the slave devices should be configured for the same clock polarity.

The master device starts a transmission by sending out the MSb from its shift register. The slave device reads this bit from that same line and saves it into the LSb position of its shift register.

During each SPI clock cycle, a full-duplex data transmission occurs. This means that while the master device is sending out the MSb from its shift register (on its SDO pin) and the slave device is reading this bit and saving it as the LSb of its shift register, that the slave device is also sending out the MSb from its shift register (on its SDO pin) and the master device is reading this bit and saving it as the LSb of its shift register.

After eight bits have been shifted out, the master and slave have exchanged register values.

If there is more data to exchange, the shift registers are loaded with new data and the process repeats itself.

Whether the data is meaningful or not (dummy data), depends on the application software. This leads to three scenarios for data transmission:

- Master sends useful data and slave sends dummy data.
- Master sends useful data and slave sends useful data.

- Master sends dummy data and slave sends useful data.

Transmissions may involve any number of clock cycles. When there is no more data to be transmitted, the master stops sending the clock signal and it deselects the slave.

Every slave device connected to the bus that has not been selected through its slave select line must disregard the clock and transmission signals and must not transmit out any data of its own.

When initializing the SPI, several options need to be specified. This is done by programming the appropriate control bits (SSPxCON1<5:0> and SSPxSTAT<7:6>). These control bits allow the following to be specified:

- Master mode (SCK is the clock output)
- Slave mode (SCK is the clock input)
- Clock Polarity (Idle state of SCK)
- Data Input Sample Phase (middle or end of data output time)
- Clock Edge (output data on rising/falling edge of SCK)
- Clock Rate (Master mode only)
- Slave Select mode (Slave mode only)

To enable the serial port, SSP Enable bit, **SSPEN**, must be set. To reset or reconfigure SPI mode, clear the SSPEN bit, re-initialize the SSPxCONx registers and then set the SSPEN bit. The SDI, SDO, SCK and  $\overline{SS}$  serial port pins are selected with the PPS controls. For the pins to behave as the serial port function, some must have their data direction bits (in the TRIS register) appropriately programmed as follows:

- SDI must have corresponding TRIS bit set
- SDO must have corresponding TRIS bit cleared
- SCK (Master mode) must have corresponding TRIS bit cleared
- SCK (Slave mode) must have corresponding TRIS bit set
- The RxyPPS and SSPxCLKPPS controls must select the same pin
- $\overline{SS}$  must have corresponding TRIS bit set

Any serial port function that is not desired may be overridden by programming the corresponding data direction (TRIS) register to the opposite value.

The MSSP consists of a transmit/receive shift register (SSPSR) and a buffer register (SSPxBUF). The SSPSR shifts the data in and out of the device, MSb first. The SSPxBUF holds the data that was written to the SSPSR until the received data is ready. Once the eight bits of data have been received, that byte is moved to the SSPxBUF register. Then, the Buffer Full Detect bit, **BF**, and the interrupt flag bit, SSPxIF, are set. This double-buffering of the received data (SSPxBUF) allows the next byte to start reception before reading the data that was just received. Any write to the SSPxBUF register during transmission/reception of data will be ignored and the write collision detect bit, **WCOL**, will be set. User software must clear the WCOL bit to allow the following write(s) to the SSPxBUF register to complete successfully.

When the application software is expecting to receive valid data, the SSPxBUF should be read before the next byte of data to transfer is written to the SSPxBUF. The Buffer Full bit, **BF**, indicates when SSPxBUF has been loaded with the received data (transmission is complete). When the SSPxBUF is read, the BF bit is cleared. This data may be irrelevant if the SPI is only a transmitter. Generally, the MSSP interrupt is used to determine when the transmission/reception has completed. If the interrupt method is not going to be used, then software polling can be done to ensure that a write collision does not occur.



The SSPSR is not directly readable or writable and can only be accessed by addressing the SSPxBUF register. Additionally, the SSPxSTAT register indicates the various Status conditions.

### 35.2.1 SPI Master Mode

The master can initiate the data transfer at any time because it controls the SCK line. The master determines when the slave (Processor 2, [Figure 35-3](#)) is to broadcast data by the software protocol.

In Master mode, the data is transmitted/received as soon as the SSPxBUF register is written to. If the SPI is only going to receive, the SDO output could be disabled (programmed as an input). The SSPSR register will continue to shift in the signal present on the SDI pin at the programmed clock rate. As each byte is received, it will be loaded into the SSPxBUF register as if a normal received byte (interrupts and Status bits appropriately set).

The clock polarity is selected by appropriately programming the CKP bit and the CKE bit. This then, would give waveforms for SPI communication as shown in [Figure 35-4](#), [Figure 35-6](#), [Figure 35-7](#) and [Figure 35-8](#), where the MSB is transmitted first. In Master mode, the SPI clock rate (bit rate) is user programmable to be one of the following:

- $F_{OSC}/4$  (or  $T_{CY}$ )
- $F_{OSC}/16$  (or  $4 * T_{CY}$ )
- $F_{OSC}/64$  (or  $16 * T_{CY}$ )
- Timer2 output/2
- $F_{OSC}/(4 * (SSPxADD + 1))$

[Figure 35-4](#) shows the waveforms for Master mode.

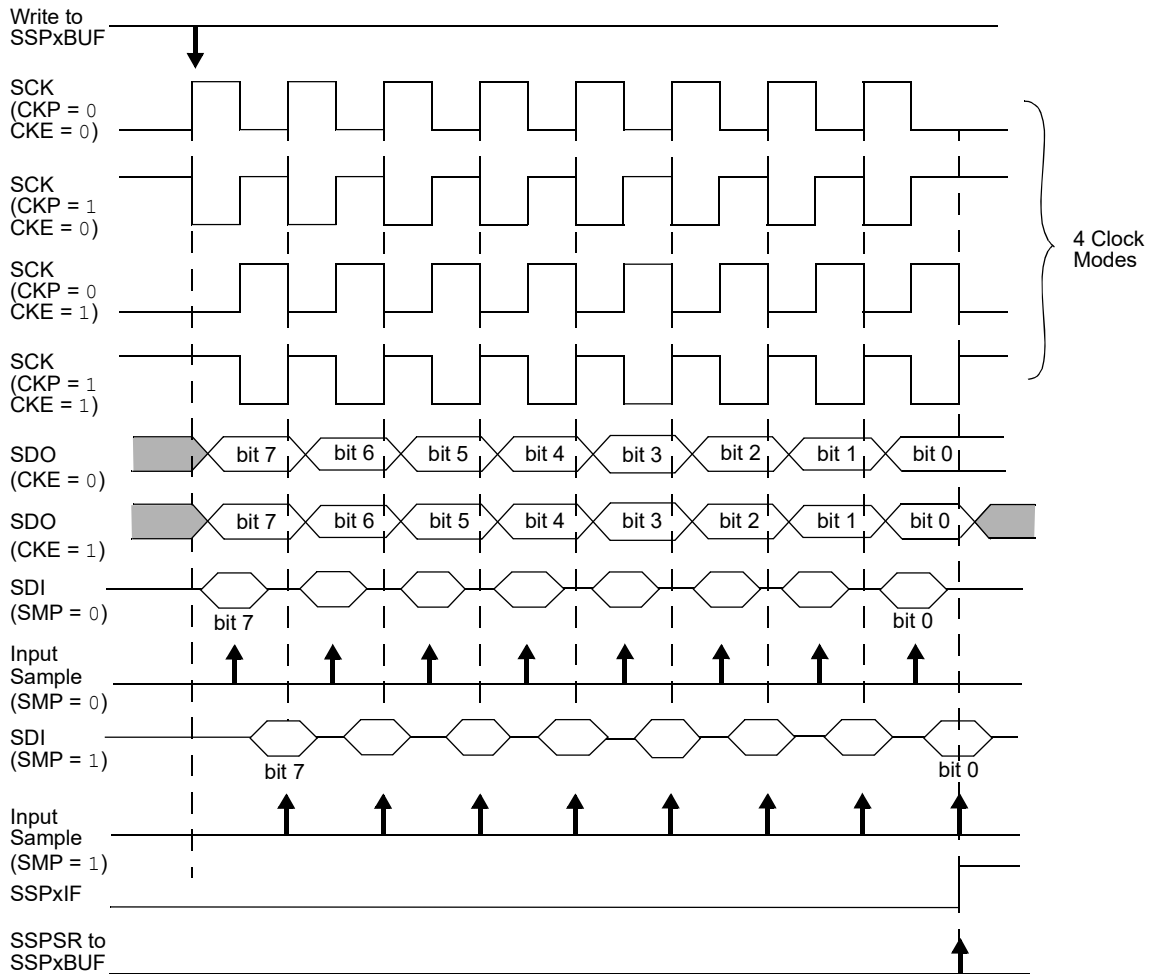
When the CKE bit is set, the SDO data is valid before there is a clock edge on SCK. The change of the input sample is shown based on the state of the SMP bit. The time when the SSPxBUF is loaded with the received data is shown.



**Important:** In Master mode the clock signal output to the SCK pin is also the clock signal input to the peripheral. The pin selected for output with the RxyPPS register must also be selected as the peripheral input with the SSPxCLKPPS register. The pin that is selected using the SSPxCLKPPS register should also be made a digital I/O. This is done by clearing the corresponding ANSEL bit.

**Figure 35-4. SPI Mode Waveform (Master Mode)**

Rev. 30-000014A  
3/13/2017



### 35.2.2 SPI Slave Mode

In Slave mode, the data is transmitted and received as external clock pulses appear on SCK. When the last bit is latched, the SSPxIF interrupt flag bit is set.

Before enabling the module in SPI Slave mode, the clock line must match the proper Idle state. The clock line can be observed by reading the SCK pin. The Idle state is determined by the CKP bit.

While in Slave mode, the external clock is supplied by the external clock source on the SCK pin. This external clock must meet the minimum high and low times as specified in the electrical specifications.

While in Sleep mode, the slave can transmit/receive data. The shift register is clocked from the SCK pin input and when a byte is received, the device will generate an interrupt. If enabled, the device will wake-up from Sleep.

### 35.2.3 Daisy-Chain Configuration

The SPI bus can sometimes be connected in a daisy-chain configuration. The first slave output is connected to the second slave input, the second slave output is connected to the third slave input, and so on. The final slave output is connected to the master input. Each slave sends out, during a second group of clock pulses, an exact copy of what was received during the first group of clock pulses. The whole

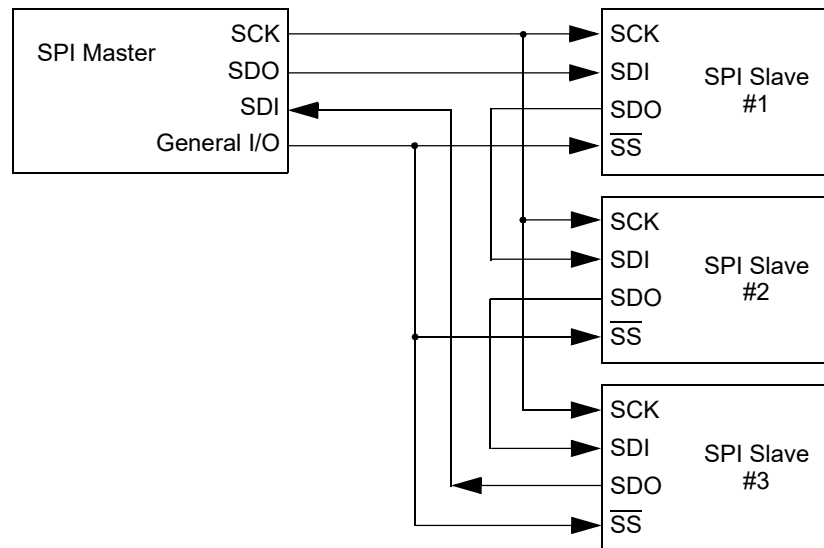
# PIC16(L)F18455/56

## (MSSP) Master Synchronous Serial Port Module

chain acts as one large communication shift register. The daisy-chain feature only requires a single Slave Select line from the master device.

The following figure shows the block diagram of a typical daisy-chain connection when operating in SPI mode.

**Figure 35-5. SPI Daisy-Chain Connection**



In a daisy-chain configuration, only the most recent byte on the bus is required by the slave. Setting the **BOEN** bit will enable writes to the SSPxBUF register, even if the previous byte has not been read. This allows the software to ignore data that may not apply to it.

### 35.2.4 Slave Select Synchronization

The Slave Select can also be used to synchronize communication. The Slave Select line is held high until the master device is ready to communicate. When the Slave Select line is pulled low, the slave knows that a new transmission is starting.

If the slave fails to receive the communication properly, it will be reset at the end of the transmission, when the Slave Select line returns to a high state. The slave is then ready to receive a new transmission when the Slave Select line is pulled low again. If the Slave Select line is not used, there is a risk that the slave will eventually become out of sync with the master. If the slave misses a bit, it will always be one bit off in future transmissions. Use of the Slave Select line allows the slave and master to align themselves at the beginning of each transmission.

The  $\overline{SS}$  pin allows a Synchronous Slave mode. The SPI must be in Slave mode with  $\overline{SS}$  pin control enabled (**SSPM** = 0100).

When the  $\overline{SS}$  pin is low, transmission and reception are enabled and the SDO pin is driven.

When the  $\overline{SS}$  pin goes high, the SDO pin is no longer driven, even if in the middle of a transmitted byte and becomes a floating output. External pull-up/pull-down resistors may be desirable depending on the application.

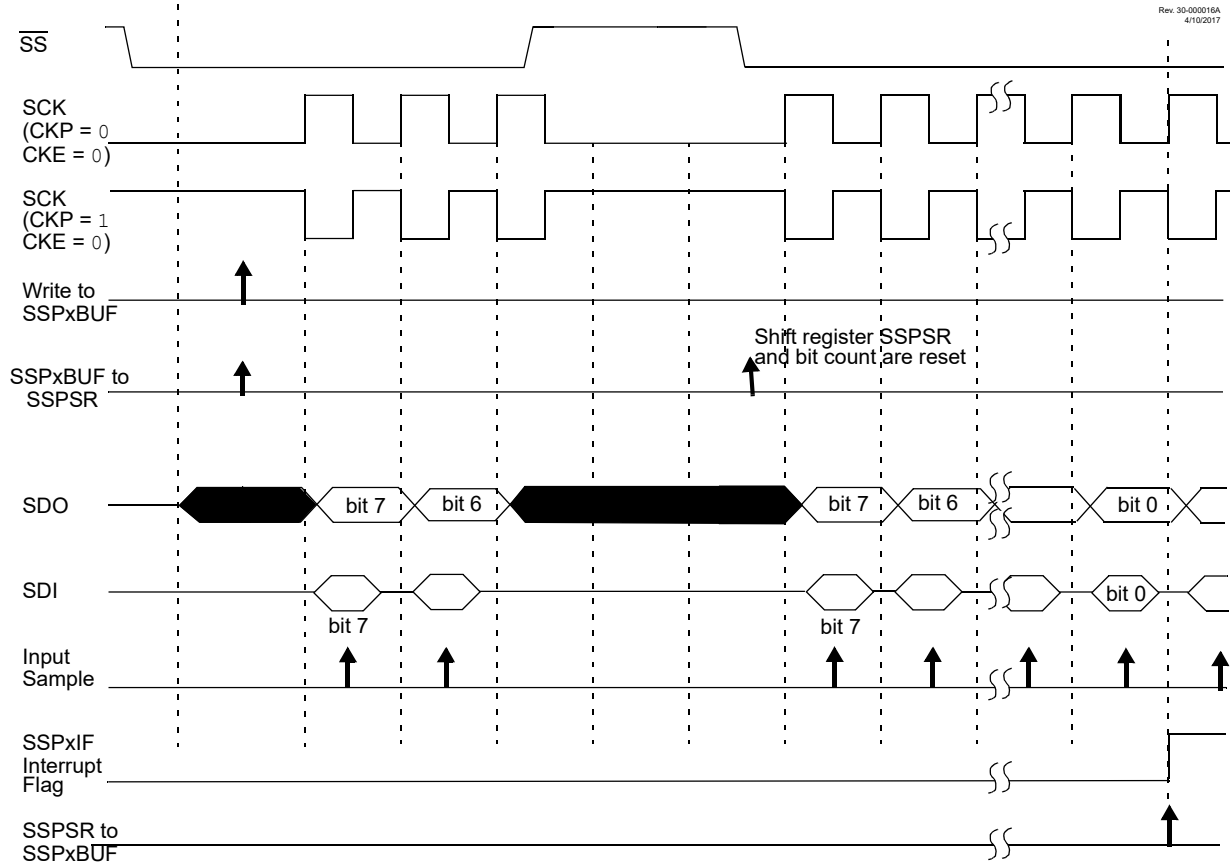
#### Note:

1. When the SPI is in Slave mode with  $\overline{SS}$  pin control enabled (**SSPM** = 0100), the SPI module will reset if the  $\overline{SS}$  pin is set to  $V_{DD}$ .

2. When the SPI is used in Slave mode with **CKE** set; the user must enable  $\overline{SS}$  pin control.
3. While operated in SPI Slave mode the **SMP** bit must remain clear.

When the SPI module resets, the bit counter is forced to '0'. This can be done by either forcing the  $\overline{SS}$  pin to a high level or clearing the SSPEN bit.

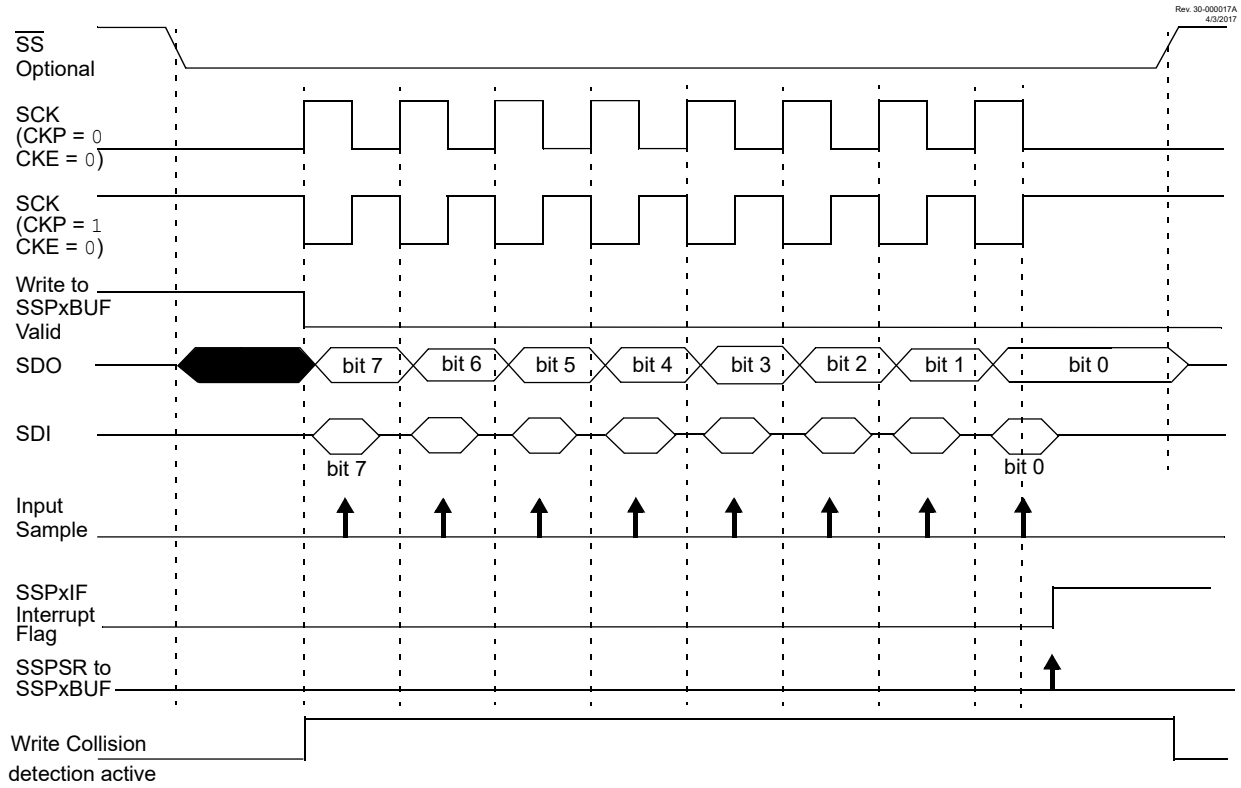
**Figure 35-6. Slave Select Synchronous Waveform**



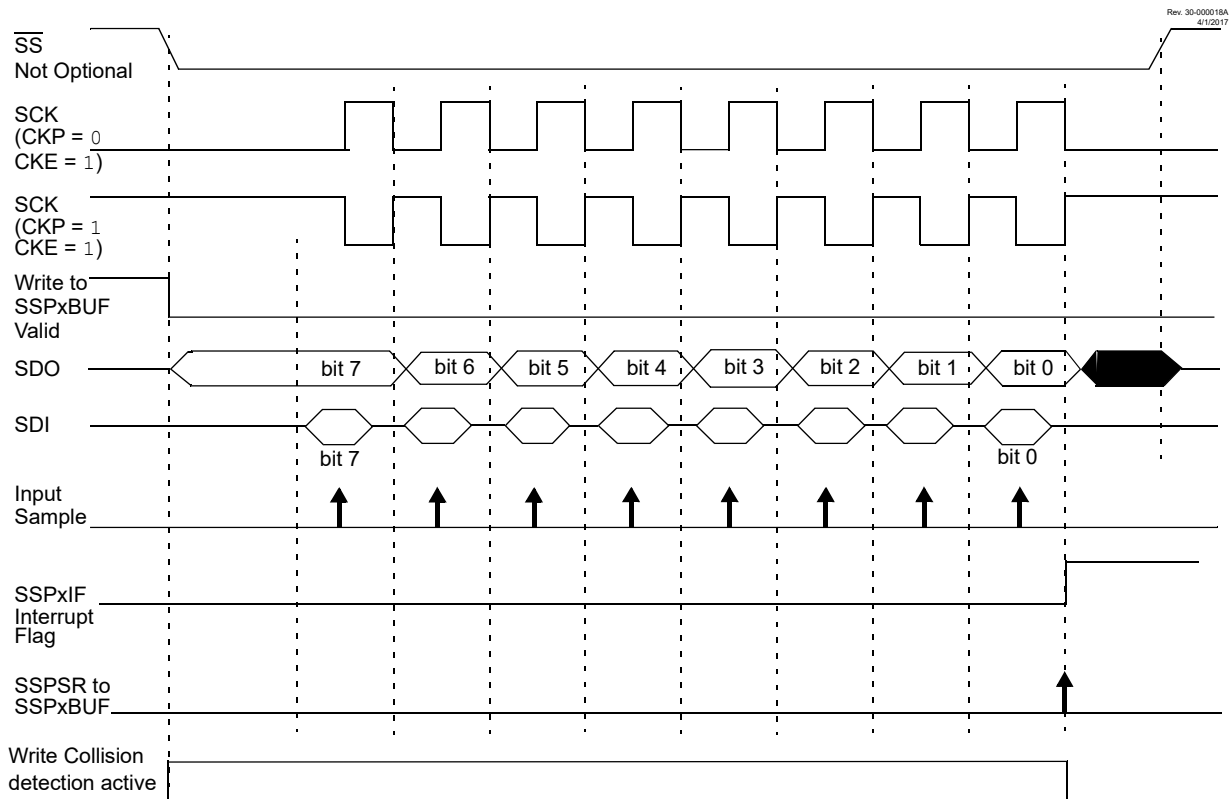
# PIC16(L)F18455/56

## (MSSP) Master Synchronous Serial Port Module

**Figure 35-7. SPI Mode Waveform (Slave Mode with CKE = 0)**



**Figure 35-8. SPI Mode Waveform (Slave Mode with CKE = 1)**



### 35.2.5 SPI Operation in Sleep Mode

In SPI Master mode, module clocks may be operating at a different speed than when in Full-Power mode; in the case of the Sleep mode, all clocks are halted.

Special care must be taken by the user when the MSSP clock is much faster than the system clock.

In Slave mode, when MSSP interrupts are enabled, after the master completes sending data, an MSSP interrupt will wake the controller from Sleep.

If an exit from Sleep mode is not desired, MSSP interrupts should be disabled.

In SPI Master mode, when the Sleep mode is selected, all module clocks are halted and the transmission/reception will remain in that state until the device wakes. After the device returns to Run mode, the module will resume transmitting and receiving data.

In SPI Slave mode, the SPI Transmit/Receive Shift register operates asynchronously to the device. This allows the device to be placed in Sleep mode and data to be shifted into the SPI Transmit/Receive Shift register. When all eight bits have been received, the MSSP interrupt flag bit will be set and if enabled, will wake the device.

## 35.3 I<sup>2</sup>C Mode Overview

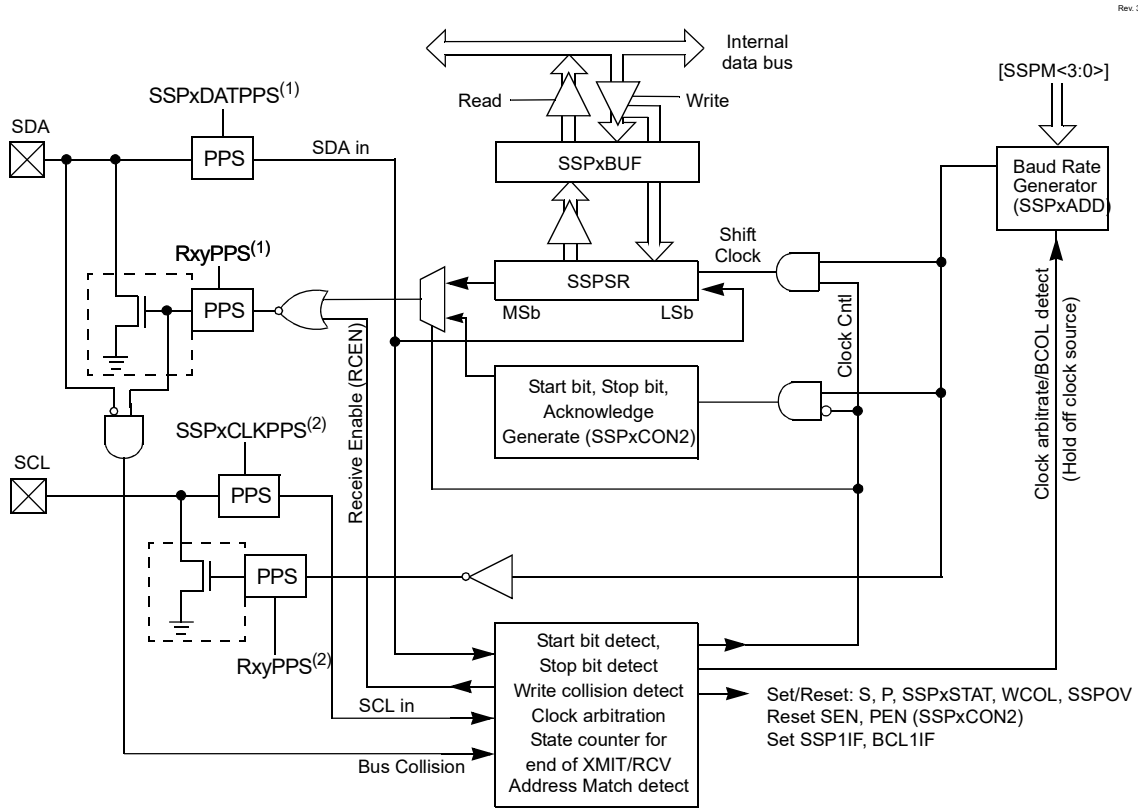
The Inter-Integrated Circuit (I<sup>2</sup>C) bus is a multi-master serial data communication bus. Devices communicate in a master/slave environment where the master devices initiate the communication. A

# PIC16(L)F18455/56

## (MSSP) Master Synchronous Serial Port Module

slave device is controlled through addressing. The following two diagrams show block diagrams of the I<sup>2</sup>C Master and Slave modes, respectively.

**Figure 35-9. MSSP Block Diagram (I<sup>2</sup>C Master mode)**

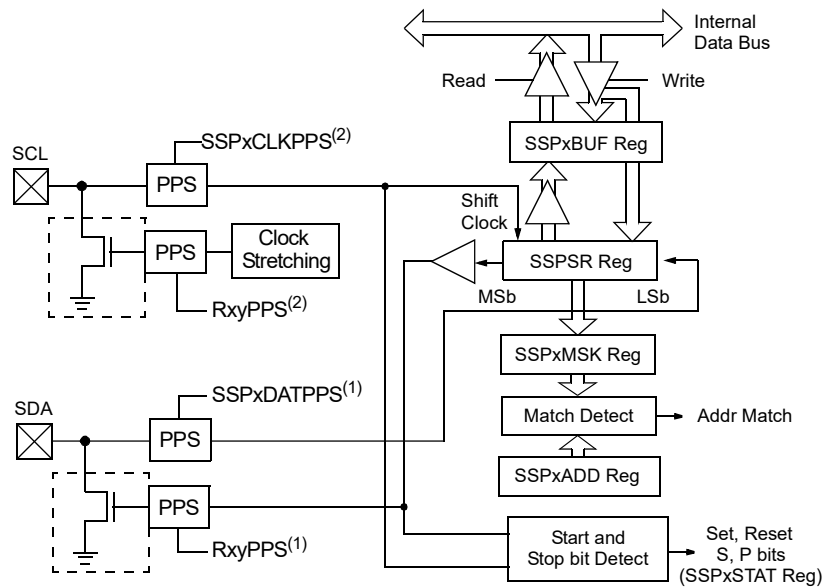


- Note 1:** SDA pin selections must be the same for input and output  
**Note 2:** SCL pin selections must be the same for input and output

# PIC16(L)F18455/56

## (MSSP) Master Synchronous Serial Port Module

**Figure 35-10. MSSP Block Diagram (I<sup>2</sup>C Slave mode)**



- Note 1:** SDA pin selections must be the same for input and output  
**Note 2:** SCL pin selections must be the same for input and output

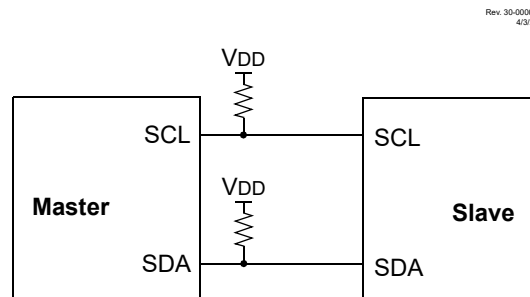
The I<sup>2</sup>C bus specifies two signal connections:

- Serial Clock (SCL)
- Serial Data (SDA)

Both the SCL and SDA connections are bidirectional open-drain lines, each requiring pull-up resistors for the supply voltage. Pulling the line to ground is considered a logical zero and letting the line float is considered a logical one.

The following diagram shows a typical connection between two processors configured as master and slave devices.

**Figure 35-11. I<sup>2</sup>C Master/ Slave Connection**



The I<sup>2</sup>C bus can operate with one or more master devices and one or more slave devices.

There are four potential modes of operation for a given device:



# PIC16(L)F18455/56

## (MSSP) Master Synchronous Serial Port Module

---

- Master Transmit mode  
(master is transmitting data to a slave)
- Master Receive mode  
(master is receiving data from a slave)
- Slave Transmit mode  
(slave is transmitting data to a master)
- Slave Receive mode  
(slave is receiving data from the master)

To begin communication, a master device starts out in Master Transmit mode. The master device sends out a Start bit followed by the address byte of the slave it intends to communicate with. This is followed by a single Read/Write bit, which determines whether the master intends to transmit to or receive data from the slave device.

If the requested slave exists on the bus, it will respond with an Acknowledge bit, otherwise known as an  $\overline{\text{ACK}}$ . The master then continues in either Transmit mode or Receive mode and the slave continues in the complement, either in Receive mode or Transmit mode, respectively.

A Start bit is indicated by a high-to-low transition of the SDA line while the SCL line is held high. Address and data bytes are sent out, Most Significant bit (MSb) first. The Read/Write bit is sent out as a logical one when the master intends to read data from the slave, and is sent out as a logical zero when it intends to write data to the slave.

The Acknowledge bit ( $\overline{\text{ACK}}$ ) is an active-low signal, which holds the SDA line low to indicate to the transmitter that the slave device has received the transmitted data and is ready to receive more.

The transition of a data bit is always performed while the SCL line is held low. Transitions that occur while the SCL line is held high are used to indicate Start and Stop bits.

If the master intends to write to the slave, then it repeatedly sends out a byte of data, with the slave responding after each byte with an  $\overline{\text{ACK}}$  bit. In this example, the master device is in Master Transmit mode and the slave is in Slave Receive mode.

If the master intends to read from the slave, then it repeatedly receives a byte of data from the slave, and responds after each byte with an  $\overline{\text{ACK}}$  bit. In this example, the master device is in Master Receive mode and the slave is Slave Transmit mode.

On the last byte of data communicated, the master device may end the transmission by sending a Stop bit. If the master device is in Receive mode, it sends the Stop bit in place of the last  $\overline{\text{ACK}}$  bit. A Stop bit is indicated by a low-to-high transition of the SDA line while the SCL line is held high.

In some cases, the master may want to maintain control of the bus and re-initiate another transmission. If so, the master device may send another Start bit in place of the Stop bit or last  $\overline{\text{ACK}}$  bit when it is in receive mode.

The I<sup>2</sup>C bus specifies three message protocols;

- Single message where a master writes data to a slave.
- Single message where a master reads data from a slave.
- Combined message where a master initiates a minimum of two writes, or two reads, or a combination of writes and reads, to one or more slaves.

When one device is transmitting a logical one, or letting the line float, and a second device is transmitting a logical zero, or holding the line low, the first device can detect that the line is not a logical one. This detection, when used on the SCL line, is called clock stretching. Clock stretching gives slave devices a

mechanism to control the flow of data. When this detection is used on the SDA line, it is called arbitration. Arbitration ensures that there is only one master device communicating at any single time.

### 35.3.1 Register Definitions: I<sup>2</sup>C Mode

The MSSPx module has seven registers for I<sup>2</sup>C operation.

These are:

- MSSP Status register (SSPxSTAT)
- MSSP Control register 1 (SSPxCON1)
- MSSP Control register 2 (SSPxCON2)
- MSSP Control register 3 (SSPxCON3)
- Serial Receive/Transmit Buffer register (SSPxBUF)
- MSSP Address register (SSPxADD)
- I<sup>2</sup>C Slave Address Mask register (SSPxMSK)
- MSSP Shift register (SSPSR) – not directly accessible

SSPxCON1, SSPxCON2, SSPxCON3 and SSPxSTAT are the Control and STATUS registers in I<sup>2</sup>C mode operation. The SSPxCON1, SSPxCON2, and SSPxCON3 registers are readable and writable. The lower six bits of the SSPxSTAT are read-only. The upper two bits of the SSPxSTAT are read/write. SSPSR is the Shift register used for shifting data in or out. SSPxBUF is the buffer register to which data bytes are written to or read from. SSPxADD contains the slave device address when the MSSP is configured in I<sup>2</sup>C Slave mode. When the MSSP is configured in Master mode, the lower seven bits of SSPxADD act as the Baud Rate Generator reload value.

SSPxMSK holds the slave address mask value when the module is configured for 7-Bit Address Masking mode. While it is a separate register, it shares the same SFR address as SSPxADD; it is only accessible when the SSPM<3:0> bits are specifically set to permit access. In receive operations, SSPSR and SSPxBUF together, create a double-buffered receiver. When SSPSR receives a complete byte, it is transferred to SSPxBUF and the SSPxIF interrupt is set. During transmission, the SSPxBUF is not double-buffered. A write to SSPxBUF will write to both SSPxBUF and SSPSR.

## 35.4 I<sup>2</sup>C Mode Operation

All MSSP I<sup>2</sup>C communication is byte oriented and shifted out MSb first. Six SFR registers and two interrupt flags interface the module with the PIC<sup>®</sup> microcontroller and user software. Two pins, SDA and SCL, are exercised by the module to communicate with other external I<sup>2</sup>C devices.

### 35.4.1 Clock Stretching

When a slave device has not completed processing data, it can delay the transfer of more data through the process of clock stretching. An addressed slave device may hold the SCL clock line low after receiving or sending a bit, indicating that it is not yet ready to continue. The master that is communicating with the slave will attempt to raise the SCL line in order to transfer the next bit, but will detect that the clock line has not yet been released. Because the SCL connection is open-drain, the slave has the ability to hold that line low until it is ready to continue communicating.

Clock stretching allows receivers that cannot keep up with a transmitter to control the flow of incoming data.

### 35.4.2 Arbitration

Each master device must monitor the bus for Start and Stop bits. If the device detects that the bus is busy, it cannot begin a new message until the bus returns to an Idle state.

However, two master devices may try to initiate a transmission on or about the same time. When this occurs, the process of arbitration begins. Each transmitter checks the level of the SDA data line and compares it to the level that it expects to find. The first transmitter to observe that the two levels do not match, loses arbitration, and must stop transmitting on the SDA line.

For example, if one transmitter holds the SDA line to a logical one (lets it float) and a second transmitter holds it to a logical zero (pulls it low), the result is that the SDA line will be low. The first transmitter then observes that the level of the line is different than expected and concludes that another transmitter is communicating.

The first transmitter to notice this difference is the one that loses arbitration and must stop driving the SDA line. If this transmitter is also a master device, it also must stop driving the SCL line. It then can monitor the lines for a Stop condition before trying to reissue its transmission. In the meantime, the other device that has not noticed any difference between the expected and actual levels on the SDA line continues with its original transmission. It can do so without any complications, because so far, the transmission appears exactly as expected with no other transmitter disturbing the message.

Slave Transmit mode can also be arbitrated, when a master addresses multiple slaves, but this is less common.

If two master devices are sending a message to two different slave devices at the address stage, the master sending the lower slave address always wins arbitration. When two master devices send messages to the same slave address, and addresses can sometimes refer to multiple slaves, the arbitration process must continue into the data stage.

Arbitration usually occurs very rarely, but it is a necessary process for proper multi-master support.

### 35.4.3 Byte Format

All communication in I<sup>2</sup>C is done in 9-bit segments. A byte is sent from a master to a slave or vice-versa, followed by an Acknowledge bit sent back. After the eighth falling edge of the SCL line, the device outputting data on the SDA changes that pin to an input and reads in an acknowledge value on the next clock pulse.

The clock signal, SCL, is provided by the master. Data is valid to change while the SCL signal is low, and sampled on the rising edge of the clock. Changes on the SDA line while the SCL line is high define special conditions on the bus, explained below.

### 35.4.4 Definition of I<sup>2</sup>C Terminology

There is language and terminology in the description of I<sup>2</sup>C communication that have definitions specific to I<sup>2</sup>C. That word usage is defined below and may be used in the rest of this document without explanation. This table was adapted from the Philips I<sup>2</sup>C specification.

TERM	Description
Transmitter	The device which shifts data out onto the bus.
Receiver	The device which shifts data in from the bus.
Master	The device that initiates a transfer, generates clock signals and terminates a transfer.

# PIC16(L)F18455/56

## (MSSP) Master Synchronous Serial Port Module

TERM	Description
Slave	The device addressed by the master.
Multi-master	A bus with more than one device that can initiate data transfers.
Arbitration	Procedure to ensure that only one master at a time controls the bus. Winning arbitration ensures that the message is not corrupted.
Synchronization	Procedure to synchronize the clocks of two or more devices on the bus.
Idle	No master is controlling the bus, and both SDA and SCL lines are high.
Active	Any time one or more master devices are controlling the bus.
Addressed Slave	Slave device that has received a matching address and is actively being clocked by a master.
Matching Address	Address byte that is clocked into a slave that matches the value stored in SSPxADD.
Write Request	Slave receives a matching address with $R/\overline{W}$ bit clear, and is ready to clock in data.
Read Request	Master sends an address byte with the $R/\overline{W}$ bit set, indicating that it wishes to clock data out of the Slave. This data is the next and all following bytes until a Restart or Stop.
Clock Stretching	When a device on the bus hold SCL low to stall communication.
Bus Collision	Any time the SDA line is sampled low by the module while it is outputting and expected high state.

### 35.4.5 SDA and SCL Pins

Selection of any I<sup>2</sup>C mode with the [SSPEN](#) bit set, forces the SCL and SDA pins to be open-drain. These pins should be set by the user to inputs by setting the appropriate TRIS bits.

**Note:**

1. Data is tied to output zero when an I<sup>2</sup>C mode is enabled.
2. Any device pin can be selected for SDA and SCL functions with the PPS peripheral. These functions are bidirectional. The SDA input is selected with the SSPxDATPPS registers. The SCL input is selected with the SSPxCLKPPS registers. Outputs are selected with the RxyPPS registers. It is the user's responsibility to make the selections so that both the input and the output for each function is on the same pin.

### 35.4.6 SDA Hold Time

The hold time of the SDA pin is selected by the [SDAHT](#) bit. Hold time is the time SDA is held valid after the falling edge of SCL. Setting the SDAHT bit selects a longer 300 ns minimum hold time and may help on buses with large capacitance.

#### I<sup>2</sup>C Bus Terms

### 35.4.7 Start Condition

The I<sup>2</sup>C specification defines a Start condition as a transition of SDA from a high to a low state while SCL line is high. A Start condition is always generated by the master and signifies the transition of the bus from an Idle to an Active state. [Figure 35-12](#) shows wave forms for Start and Stop conditions.

A bus collision can occur on a Start condition if the module samples the SDA line low before asserting it low. This does not conform to the I<sup>2</sup>C Specification that states no bus collision can occur on a Start.

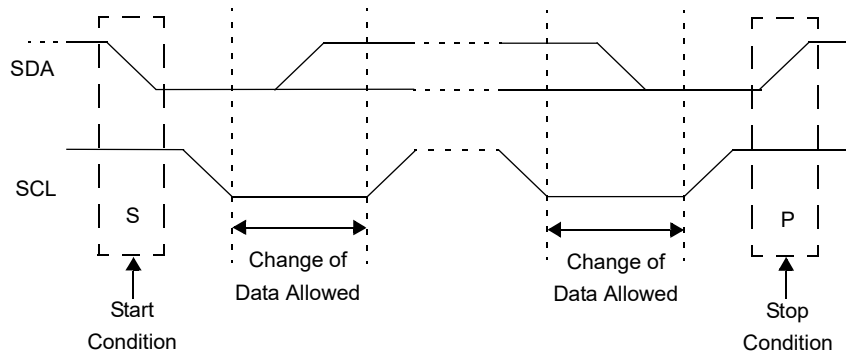
### 35.4.8 Stop Condition

A Stop condition is a transition of the SDA line from low-to-high state while the SCL line is high.



**Important:** At least one SCL low time must appear before a Stop is valid, therefore, if the SDA line goes low then high again while the SCL line stays high, only the Start condition is detected.

**Figure 35-12. I<sup>2</sup>C Start and Stop Conditions**



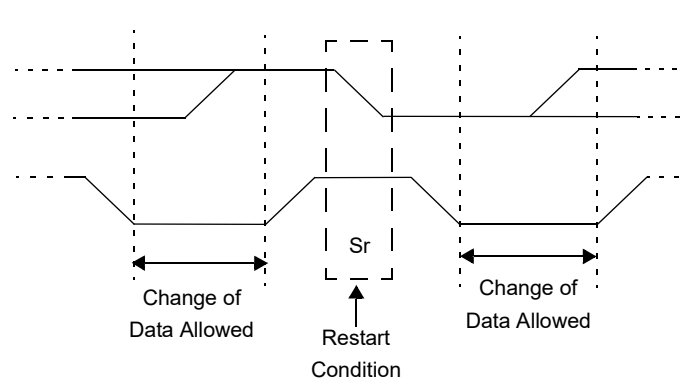
### 35.4.9 Restart Condition

A Restart is valid any time that a Stop would be valid. A master can issue a Restart if it wishes to hold the bus after terminating the current transfer. A Restart has the same effect on the slave that a Start would, resetting all slave logic and preparing it to clock in an address. The master may want to address the same or another slave. [Figure 35-13](#) shows the wave form for a Restart condition.

In 10-bit Addressing Slave mode a Restart is required for the master to clock data out of the addressed slave. Once a slave has been fully addressed, matching both high and low address bytes, the master can issue a Restart and the high address byte with the  $R/\overline{W}$  bit set. The slave logic will then hold the clock and prepare to clock out data.

After a full match with  $R/\overline{W}$  clear in 10-bit mode, a prior match flag is set and maintained until a Stop condition, a high address with  $R/\overline{W}$  clear, or high address match fails.

**Figure 35-13. I<sup>2</sup>C Restart Condition**



### 35.4.10 Start/Stop Condition Interrupt Masking

The [SCIE](#) and [PCIE](#) bits can enable the generation of an interrupt in Slave modes that do not typically support this function. These bits will have no effect in Slave modes where interrupt on Start and Stop detect are already enabled.

### 35.4.11 Acknowledge Sequence

The ninth SCL pulse for any transferred byte in I<sup>2</sup>C is dedicated as an Acknowledge. It allows receiving devices to respond back to the transmitter by pulling the SDA line low. The transmitter must release control of the line during this time to shift in the response. The Acknowledge ( $\overline{\text{ACK}}$ ) is an active-low signal, pulling the SDA line low indicates to the transmitter that the device has received the transmitted data and is ready to receive more.

The result of an  $\overline{\text{ACK}}$  is placed in the [ACKSTAT](#) bit.

Slave software, when the [AHEN](#) and [DHEN](#) bits are set, allow the user to set the  $\overline{\text{ACK}}$  value sent back to the transmitter. The [ACKDT](#) bit is set/cleared to determine the response.

Slave hardware will generate an  $\overline{\text{ACK}}$  response if both the [AHEN](#) and [DHEN](#) bits are clear. However, if the [BF](#) bit or the [SSPOV](#) bit are set when a byte is received then the  $\overline{\text{ACK}}$  will not be sent by the slave.

When the module is addressed, after the eighth falling edge of SCL on the bus, the [ACKTIM](#) bit is set. The [ACKTIM](#) bit indicates the acknowledge time of the active bus. The [ACKTIM](#) Status bit is only active when either the [AHEN](#) bit or [DHEN](#) bit is enabled.

## 35.5 I<sup>2</sup>C Slave Mode Operation

The MSSP Slave mode operates in one of four modes selected by the [SSPM](#) bits. The modes can be divided into 7-bit and 10-bit Addressing mode. 10-bit Addressing modes operate the same as 7-bit with some additional overhead for handling the larger addresses.

Modes with Start and Stop bit interrupts operate the same as the other modes with [SSPxIF](#) additionally getting set upon detection of a Start, Restart, or Stop condition.

### 35.5.1 Slave Mode Addresses

The [SSPxADD](#) register contains the Slave mode address. The first byte received after a Start or Restart condition is compared against the value stored in this register. If the byte matches, the value is loaded into the [SSPxBUF](#) register and an interrupt is generated. If the value does not match, the module goes idle and no indication is given to the software that anything happened.

The [SSPxMSK](#) register affects the address matching process. See [35.5.9 SSP Mask Register](#) for more information.

#### 35.5.1.1 I<sup>2</sup>C Slave 7-bit Addressing Mode

In 7-bit Addressing mode, the LSb of the received data byte is ignored when determining if there is an address match.

#### 35.5.1.2 I<sup>2</sup>C Slave 10-bit Addressing Mode

In 10-bit Addressing mode, the first received byte is compared to the binary value of '1 1 1 0 A9 A8 0'. A9 and A8 are the two MSb's of the 10-bit address and stored in bits 2 and 1 of the [SSPxADD](#) register.

After the acknowledge of the high byte the [UA](#) bit is set and SCL is held low until the user updates [SSPxADD](#) with the low address. The low address byte is clocked in and all eight bits are compared to the low address value in [SSPxADD](#). Even if there is not an address match; [SSPxIF](#) and [UA](#) are set, and SCL

is held low until SSPxADD is updated to receive a high byte again. When SSPxADD is updated the UA bit is cleared. This ensures the module is ready to receive the high address byte on the next communication.

A high and low address match as a write request is required at the start of all 10-bit addressing communication. A transmission can be initiated by issuing a Restart once the slave is addressed, and clocking in the high address with the  $R/\overline{W}$  bit set. The slave hardware will then acknowledge the read request and prepare to clock out data. This is only valid for a slave after it has received a complete high and low address byte match.

### 35.5.2 Slave Reception

When the  $R/\overline{W}$  bit of a matching received address byte is clear, the  $R/W$  bit is cleared. The received address is loaded into the SSPxBUF register and acknowledged.

When the overflow condition exists for a received address, then not Acknowledge is given. An overflow condition is defined as either bit **BF** is set, or bit **SSPOV** is set. The **BOEN** bit modifies this operation. For more information see SSPxCON3.

An MSSP interrupt is generated for each transferred data byte. Flag bit, SSPxIF, must be cleared by software.

When the **SEN** bit is set, SCL will be held low (clock stretch) following each received byte. The clock must be released by setting the **CKP** bit, except sometimes in 10-bit mode. See 35.5.6.2 10-bit Addressing Mode for more detail.

#### 35.5.2.1 7-bit Addressing Reception

This section describes a standard sequence of events for the MSSP module configured as an I<sup>2</sup>C slave in 7-bit Addressing mode. Figure 35-14 and Figure 35-15 is used as a visual reference for this description.

This is a step by step process of what typically must be done to accomplish I<sup>2</sup>C communication.

1. Start bit detected.
2. **S** bit is set; SSPxIF is set if interrupt on Start detect is enabled.
3. Matching address with  $R/W$  bit clear is received.
4. The slave pulls SDA low sending an  $\overline{ACK}$  to the master, and sets SSPxIF bit.
5. Software clears the SSPxIF bit.
6. Software reads received address from SSPxBUF clearing the BF flag.
7. If **SEN** = 1; Slave software sets **CKP** bit to release the SCL line.
8. The master clocks out a data byte.
9. Slave drives SDA low sending an  $\overline{ACK}$  to the master, and sets SSPxIF bit.
10. Software clears SSPxIF.
11. Software reads the received byte from SSPxBUF clearing BF.
12. Steps 8-12 are repeated for all received bytes from the master.
13. Master sends Stop condition, setting **P** bit, and the bus goes idle.

#### 35.5.2.2 7-bit Reception with AHEN and DHEN

Slave device reception with AHEN and DHEN set operate the same as without these options with extra interrupts and clock stretching added after the eighth falling edge of SCL. These additional interrupts allow the slave software to decide whether it wants to  $\overline{ACK}$  the receive address or data byte, rather than the hardware. This functionality adds support for PMBus™ that was not present on previous versions of this module.

# PIC16(L)F18455/56

## (MSSP) Master Synchronous Serial Port Module

---

This list describes the steps that need to be taken by slave software to use these options for I<sup>2</sup>C communication. [Figure 35-16](#) displays a module using both address and data holding. [Figure 35-17](#) includes the operation with the SEN bit of the SSPxCON2 register set.

1. **S** bit is set; SSPxIF is set if interrupt on Start detect is enabled.
2. Matching address with **R/W** bit clear is clocked in. SSPxIF is set and **CKP** cleared after the eighth falling edge of SCL.
3. Slave clears the SSPxIF.
4. Slave can look at the **ACKTIM** bit to determine if the SSPxIF was after or before the  $\overline{\text{ACK}}$ .
5. Slave reads the address value from SSPxBUF, clearing the BF flag.
6. Slave sets  $\overline{\text{ACK}}$  value clocked out to the master by setting **ACKDT**.
7. Slave releases the clock by setting **CKP**.
8. SSPxIF is set after an  $\overline{\text{ACK}}$ , not after a NACK.
9. If **SEN** = 1, the slave hardware will stretch the clock after the  $\overline{\text{ACK}}$ .
10. Slave clears SSPxIF.



**Important:** SSPxIF is still set after the ninth falling edge of SCL even if there is no clock stretching and BF has been cleared. Only if NACK is sent to master is SSPxIF not set

---

11. SSPxIF set and **CKP** cleared after eighth falling edge of SCL for a received data byte.
12. Slave looks at **ACKTIM** bit to determine the source of the interrupt.
13. Slave reads the received data from SSPxBUF clearing BF.
14. Steps 7-14 are the same for each received data byte.
15. Communication is ended by either the slave sending an  $\overline{\text{ACK}} = 1$ , or the master sending a Stop condition. If a Stop is sent and Interrupt on Stop Detect is disabled, the slave will only know by polling the **P** bit.



Figure 35-14. I<sup>2</sup>C Slave, 7-bit Address, Reception (SEN = 0, AHEN = 0, DHEN = 0)

Rev. 16/09/2014  
4/10/2017

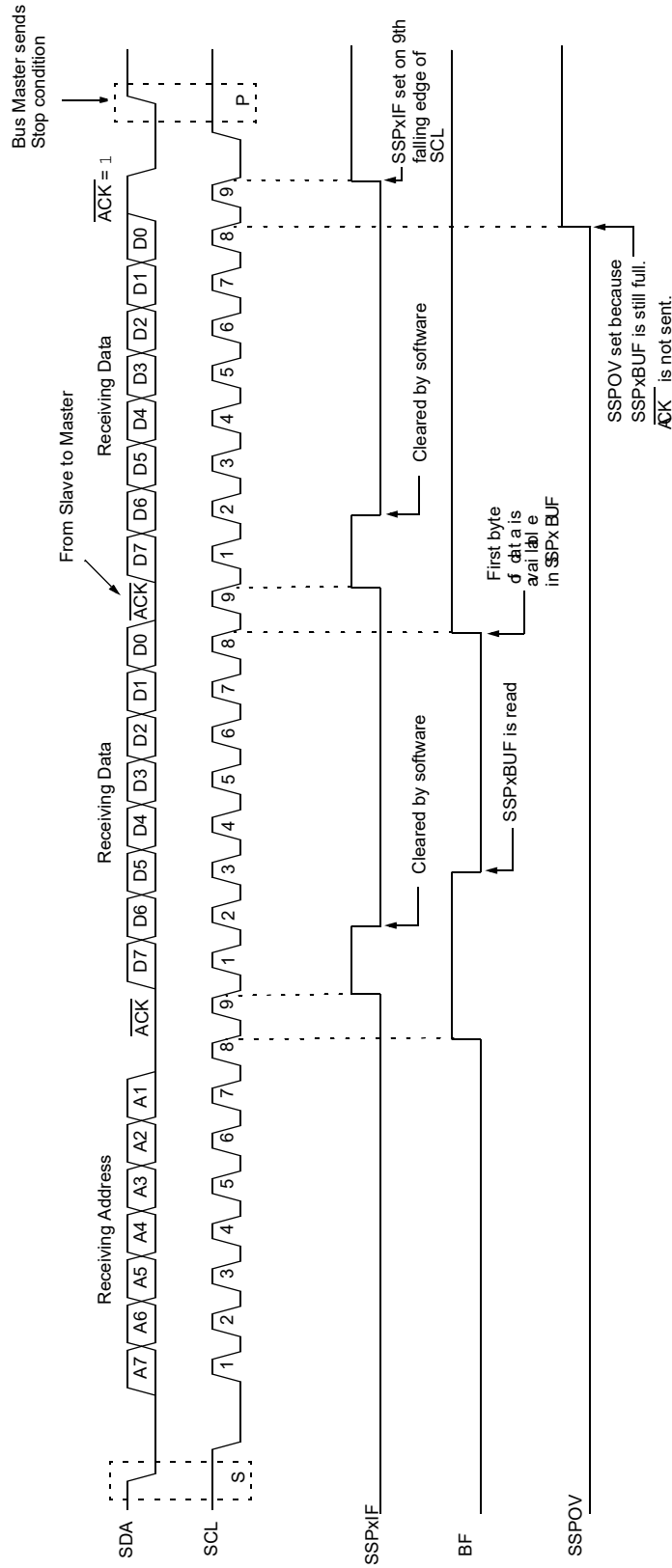


Figure 35-15. I<sup>2</sup>C Slave, 7-bit Address, Reception (SEN = 1, AHEN = 0, DHEN = 0)

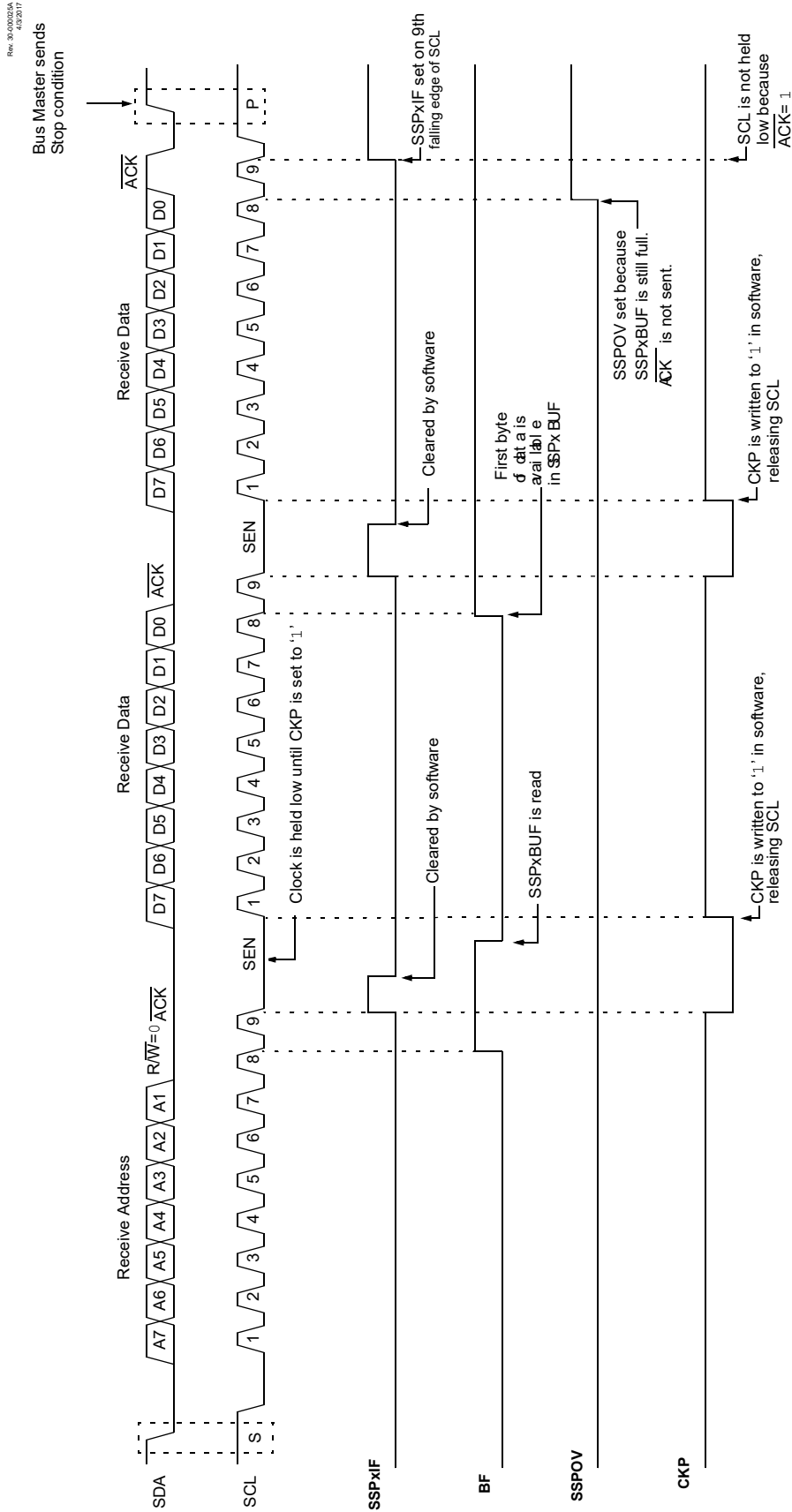


Figure 35-16. I<sup>2</sup>C Slave, 7-bit Address, Reception (SEN = 0, AHEN = 1, DHEN = 1)

Rev. 300020A  
4/2017

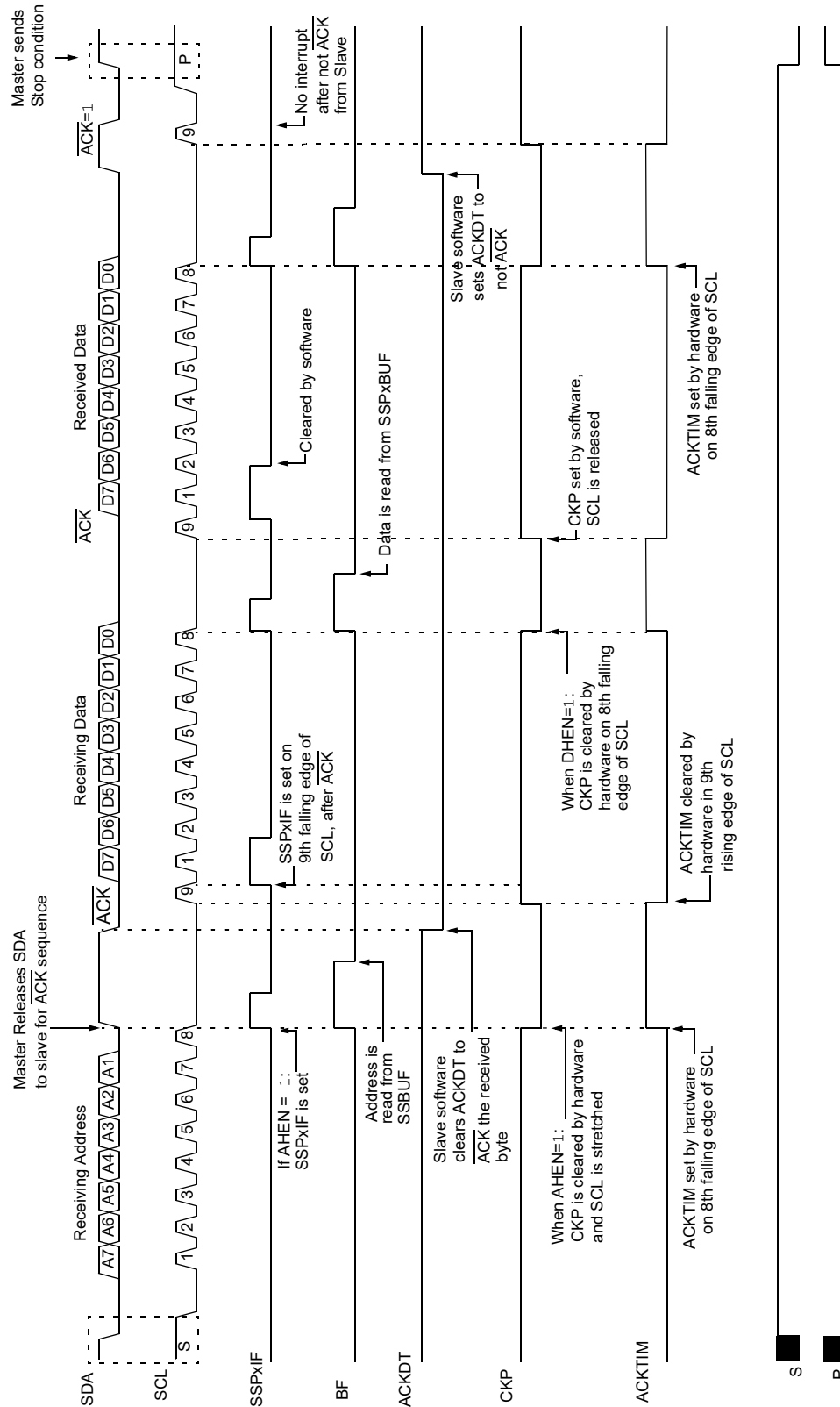
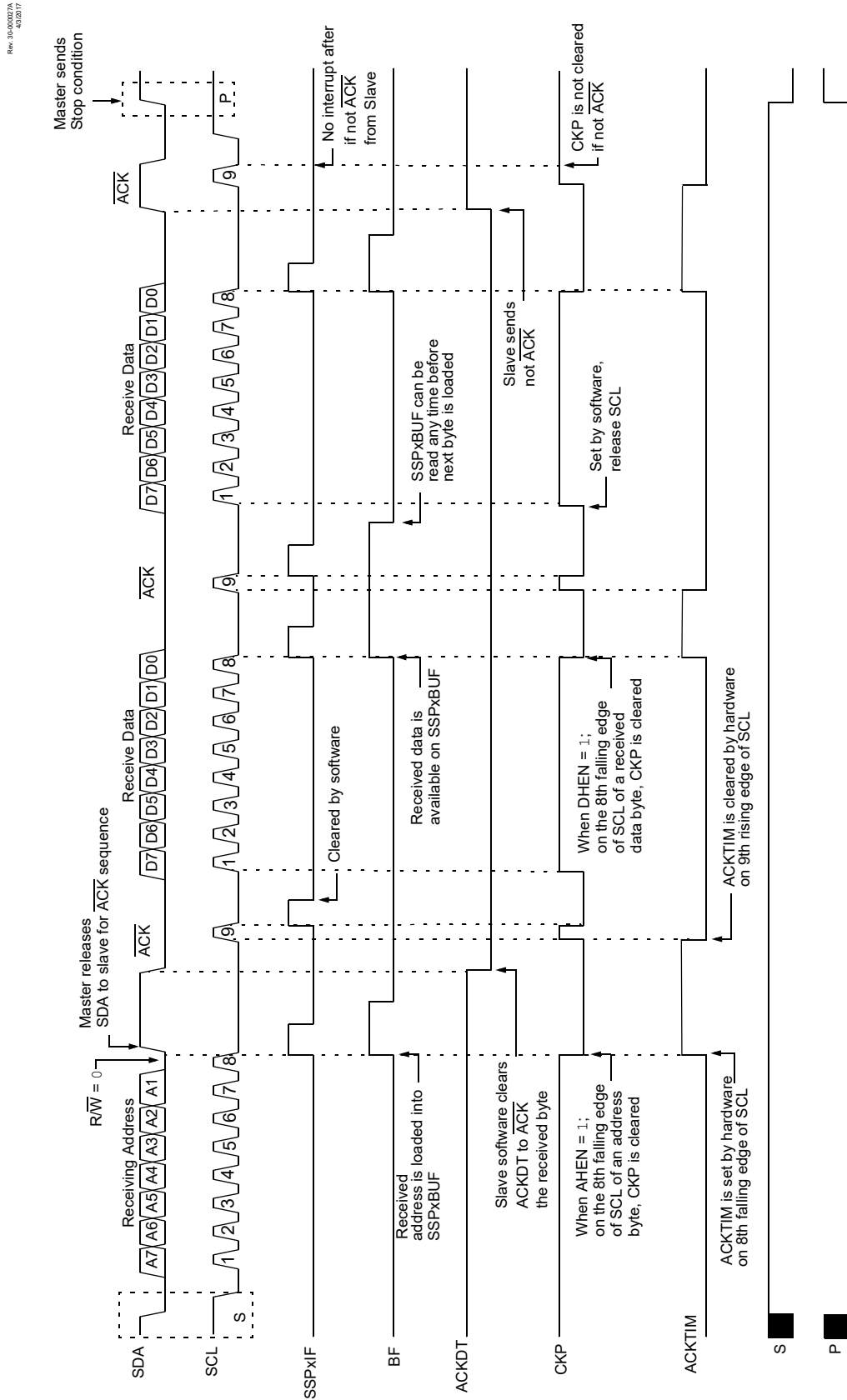


Figure 35-17. I<sup>2</sup>C Slave, 7-bit Address, Reception (SEN = 1, AHEN = 1, DHEN = 1)



### 35.5.3 Slave Transmission

When the  $R/\overline{W}$  bit of the incoming address byte is set and an address match occurs, the  $R/W$  bit is set. The received address is loaded into the SSPxBUF register, and an  $\overline{ACK}$  pulse is sent by the slave on the ninth bit.

Following the  $\overline{ACK}$ , slave hardware clears the CKP bit and the SCL pin is held low (see 35.5.6 Clock Stretching for more detail). By stretching the clock, the master will be unable to assert another clock pulse until the slave is done preparing the transmit data.

The transmit data must be loaded into the SSPxBUF register which also loads the SSPSR register. Then the SCL pin should be released by setting the CKP bit. The eight data bits are shifted out on the falling edge of the SCL input. This ensures that the SDA signal is valid during the SCL high time.

The  $\overline{ACK}$  pulse from the master-receiver is latched on the rising edge of the ninth SCL input pulse. This  $\overline{ACK}$  value is copied to the ACKSTAT bit. If ACKSTAT is set (not  $\overline{ACK}$ ), then the data transfer is complete. In this case, when the not  $\overline{ACK}$  is latched by the slave, the slave goes idle and waits for another occurrence of the Start bit. If the SDA line was low ( $\overline{ACK}$ ), the next transmit data must be loaded into the SSPxBUF register. Again, the SCL pin must be released by setting bit CKP.

An MSSP interrupt is generated for each data transfer byte. The SSPxIF bit must be cleared by software and the SSPxSTAT register is used to determine the status of the byte. The SSPxIF bit is set on the falling edge of the ninth clock pulse.

#### 35.5.3.1 Slave Mode Bus Collision

A slave receives a Read request and begins shifting data out on the SDA line. If a bus collision is detected and the SBCDE bit is set, the BCLxIF bit of the PIRx register is set. Once a bus collision is detected, the slave goes idle and waits to be addressed again. User software can use the BCLxIF bit to handle a slave bus collision.

#### 35.5.3.2 7-bit Transmission

A master device can transmit a read request to a slave, and then clock data out of the slave. The list below outlines what software for a slave will need to do to accomplish a standard transmission. Figure 35-18 can be used as a reference to this list.

1. Master sends a Start condition on SDA and SCL.
2. S bit is set; SSPxIF is set if interrupt on Start detect is enabled.
3. Matching address with  $R/\overline{W}$  bit set is received by the Slave setting SSPxIF bit.
4. Slave hardware generates an  $\overline{ACK}$  and sets SSPxIF.
5. SSPxIF bit is cleared by user.
6. Software reads the received address from SSPxBUF, clearing BF.
7.  $R/\overline{W}$  is set so CKP was automatically cleared after the  $\overline{ACK}$ .
8. The slave software loads the transmit data into SSPxBUF.
9. CKP bit is set releasing SCL, allowing the master to clock the data out of the slave.
10. SSPxIF is set after the  $\overline{ACK}$  response from the master is loaded into the ACKSTAT register.
11. SSPxIF bit is cleared.
12. The slave software checks the ACKSTAT bit to see if the master wants to clock out more data.

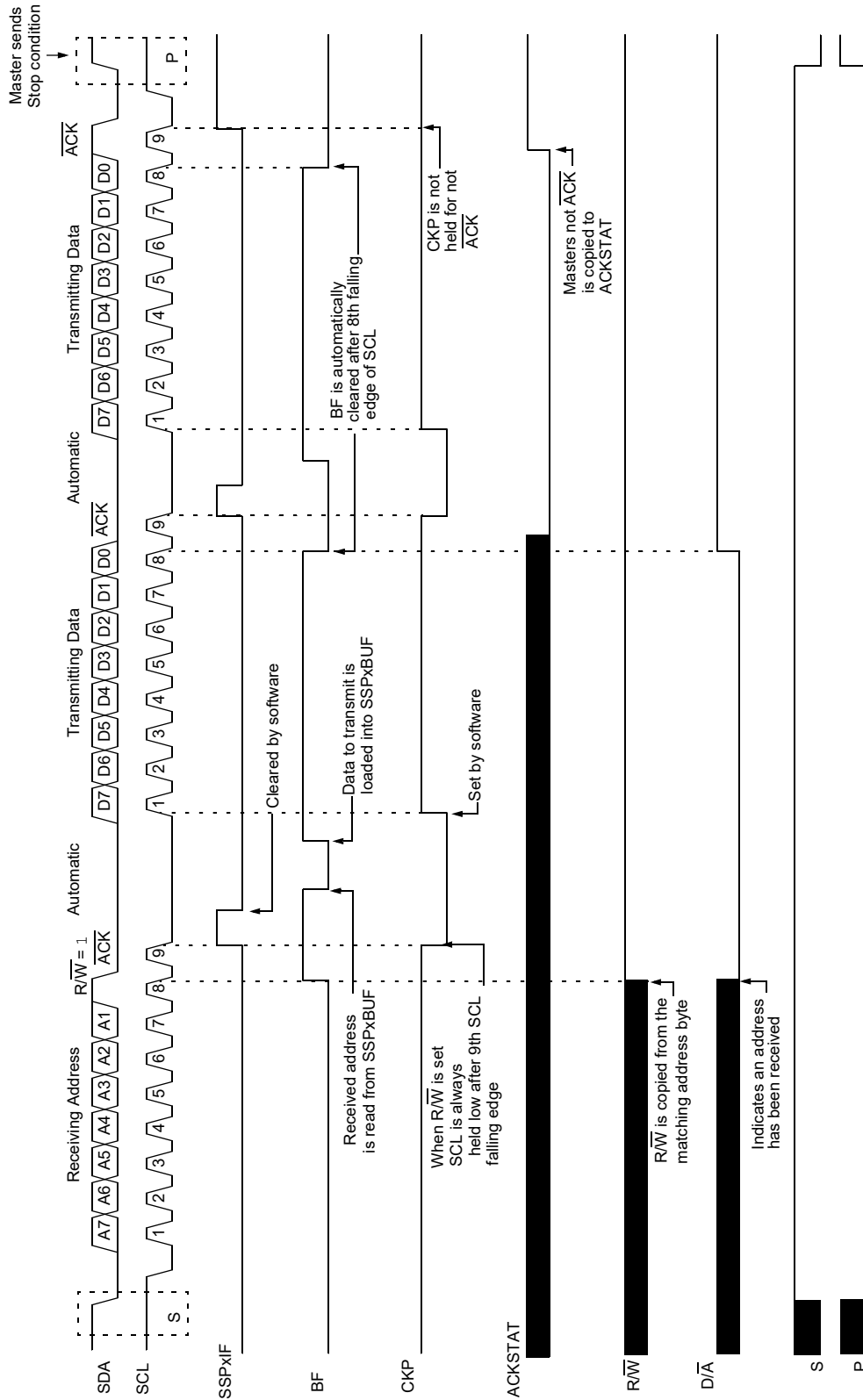


**Important:**

1. If the master  $\overline{ACK}$ s then the clock will be stretched.
  2. ACKSTAT is the only bit updated on the rising edge of the ninth SCL clock instead of the falling edge.
- 
13. Steps 9-13 are repeated for each transmitted byte.
  14. If the master sends a not  $\overline{ACK}$ ; the clock is not held, but SSPxIF is still set.
  15. The master sends a Restart condition or a Stop.
  16. The slave is no longer addressed.

Figure 35-18. I<sup>2</sup>C Slave, 7-bit Address, Transmission (AHEN = 0)

Rev. 30-000020A  
4/20/17



### 35.5.3.3 7-bit Transmission with Address Hold Enabled

Setting the **AHEN** bit enables additional clock stretching and interrupt generation after the eighth falling edge of a received matching address. Once a matching address has been clocked in, **CKP** is cleared and the **SSPxIF** interrupt is set.

Figure 35-19 displays a standard waveform of a 7-bit address slave transmission with **AHEN** enabled.

1. Bus starts Idle.
2. Master sends Start condition; the **S** bit is set; **SSPxIF** is set if interrupt on Start detect is enabled.
3. Master sends matching address with **R/W** bit set. After the eighth falling edge of the SCL line the **CKP** bit is cleared and **SSPxIF** interrupt is generated.
4. Slave software clears **SSPxIF**.
5. Slave software reads the **ACKTIM**, **R/W** and **D/A** bits to determine the source of the interrupt.
6. Slave reads the address value from the **SSPxBUF** register clearing the **BF** bit.
7. Slave software decides from this information if it wishes to  $\overline{\text{ACK}}$  or not  $\overline{\text{ACK}}$  and sets the **ACKDT** bit accordingly.
8. Slave sets the **CKP** bit releasing SCL.
9. Master clocks in the  $\overline{\text{ACK}}$  value from the slave.
10. Slave hardware automatically clears the **CKP** bit and sets **SSPxIF** after the  $\overline{\text{ACK}}$  if the **R/W** bit is set.
11. Slave software clears **SSPxIF**.
12. Slave loads value to transmit to the master into **SSPxBUF** setting the **BF** bit.



**Important:** **SSPxBUF** cannot be loaded until after the  $\overline{\text{ACK}}$ .

---

13. Slave sets the **CKP** bit releasing the clock.
14. Master clocks out the data from the slave and sends an  $\overline{\text{ACK}}$  value on the ninth SCL pulse.
15. Slave hardware copies the  $\overline{\text{ACK}}$  value into the **ACKSTAT** bit.
16. Steps 10-15 are repeated for each byte transmitted to the master from the slave.
17. If the master sends a not  $\overline{\text{ACK}}$  the slave releases the bus allowing the master to send a Stop and end the communication.

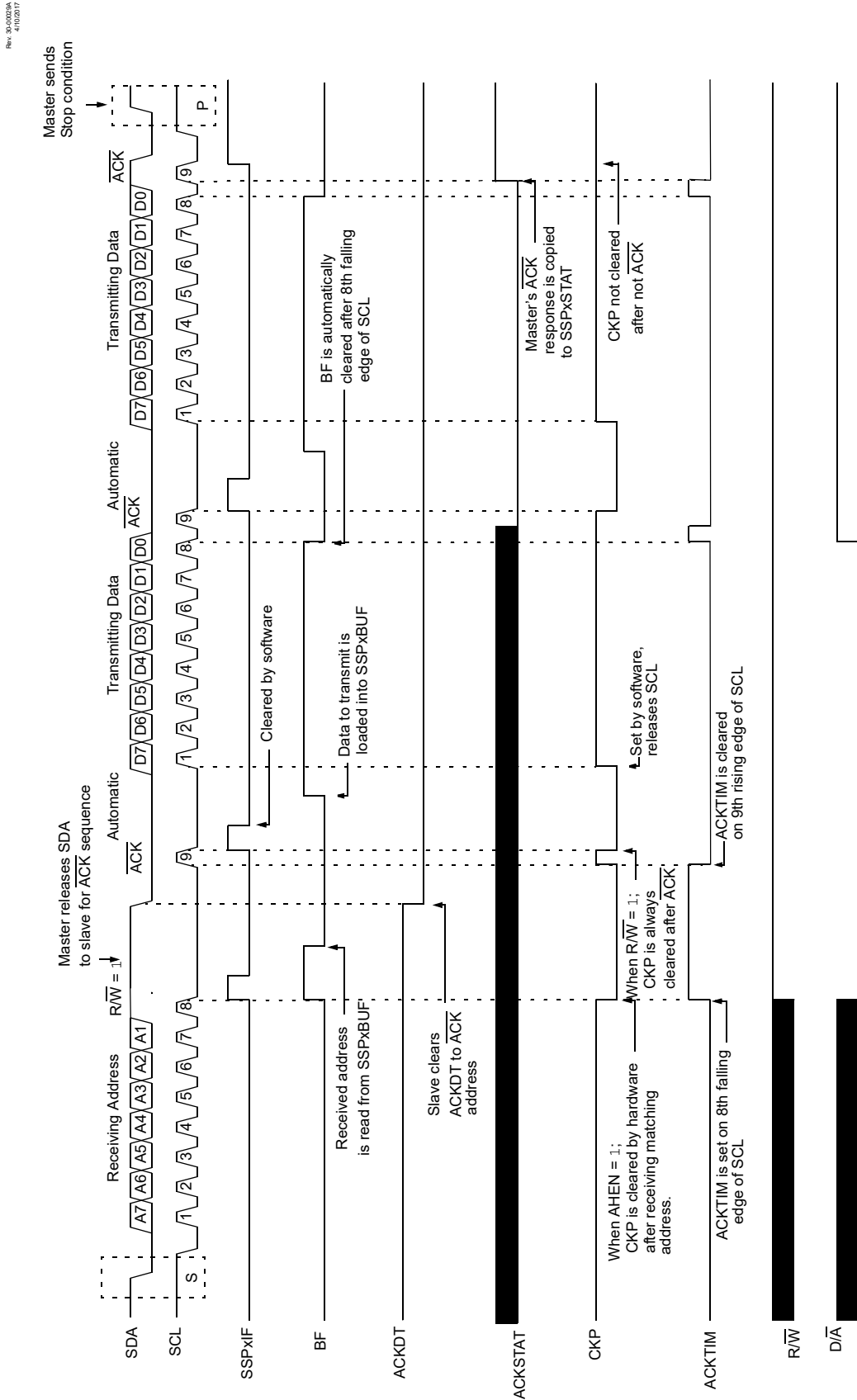


**Important:** Master must send a not  $\overline{\text{ACK}}$  on the last byte to ensure that the slave releases the SCL line to receive a Stop.

---



Figure 35-19. I<sup>2</sup>C Slave, 7-bit Address, Transmission (AHEN = 1)



#### 35.5.4 Slave Mode 10-bit Address Reception

This section describes a standard sequence of events for the MSSP module configured as an I<sup>2</sup>C slave in 10-bit Addressing mode.

Figure 35-20 is used as a visual reference for this description.

This is a step by step process of what must be done by slave software to accomplish I<sup>2</sup>C communication.

1. Bus starts Idle.
2. Master sends Start condition; **S** bit is set; SSPxIF is set if interrupt on Start detect is enabled.
3. Master sends matching high address with **R/W** bit clear; **UA** bit is set.
4. Slave sends  $\overline{\text{ACK}}$  and SSPxIF is set.
5. Software clears the SSPxIF bit.
6. Software reads received address from SSPxBUF clearing the BF flag.
7. Slave loads low address into SSPxADD, releasing SCL.
8. Master sends matching low address byte to the slave; UA bit is set.



**Important:** Updates to the SSPxADD register are not allowed until after the  $\overline{\text{ACK}}$  sequence.

---

9. Slave sends  $\overline{\text{ACK}}$  and SSPxIF is set.



**Important:** If the low address does not match, SSPxIF and UA are still set so that the slave software can set SSPxADD back to the high address. BF is not set because there is no match. **CKP** is unaffected.

---

10. Slave clears SSPxIF.
11. Slave reads the received matching address from SSPxBUF clearing BF.
12. Slave loads high address into SSPxADD.
13. Master clocks a data byte to the slave and clocks out the slaves  $\overline{\text{ACK}}$  on the ninth SCL pulse; SSPxIF is set.
14. If **SEN** bit is set, **CKP** is cleared by hardware and the clock is stretched.
15. Slave clears SSPxIF.
16. Slave reads the received byte from SSPxBUF clearing BF.
17. If **SEN** is set the slave sets **CKP** to release the SCL.
18. Steps 13-17 repeat for each received byte.
19. Master sends Stop to end the transmission.

#### 35.5.5 10-bit Addressing with Address or Data Hold

Reception using 10-bit addressing with **AHEN** or **DHEN** set is the same as with 7-bit modes. The only difference is the need to update the SSPxADD register using the **UA** bit. All functionality, specifically when the **CKP** bit is cleared and SCL line is held low are the same. Figure 35-21 can be used as a reference of a slave in 10-bit addressing with **AHEN** set.

# PIC16(L)F18455/56

## (MSSP) Master Synchronous Serial Port Module

---

---

Figure 35-22 shows a standard waveform for a slave transmitter in 10-bit Addressing mode.

Figure 35-20. I<sup>2</sup>C Slave, 10-bit Address, Reception (SEN = 1, AHEN = 0, DHEN = 0)

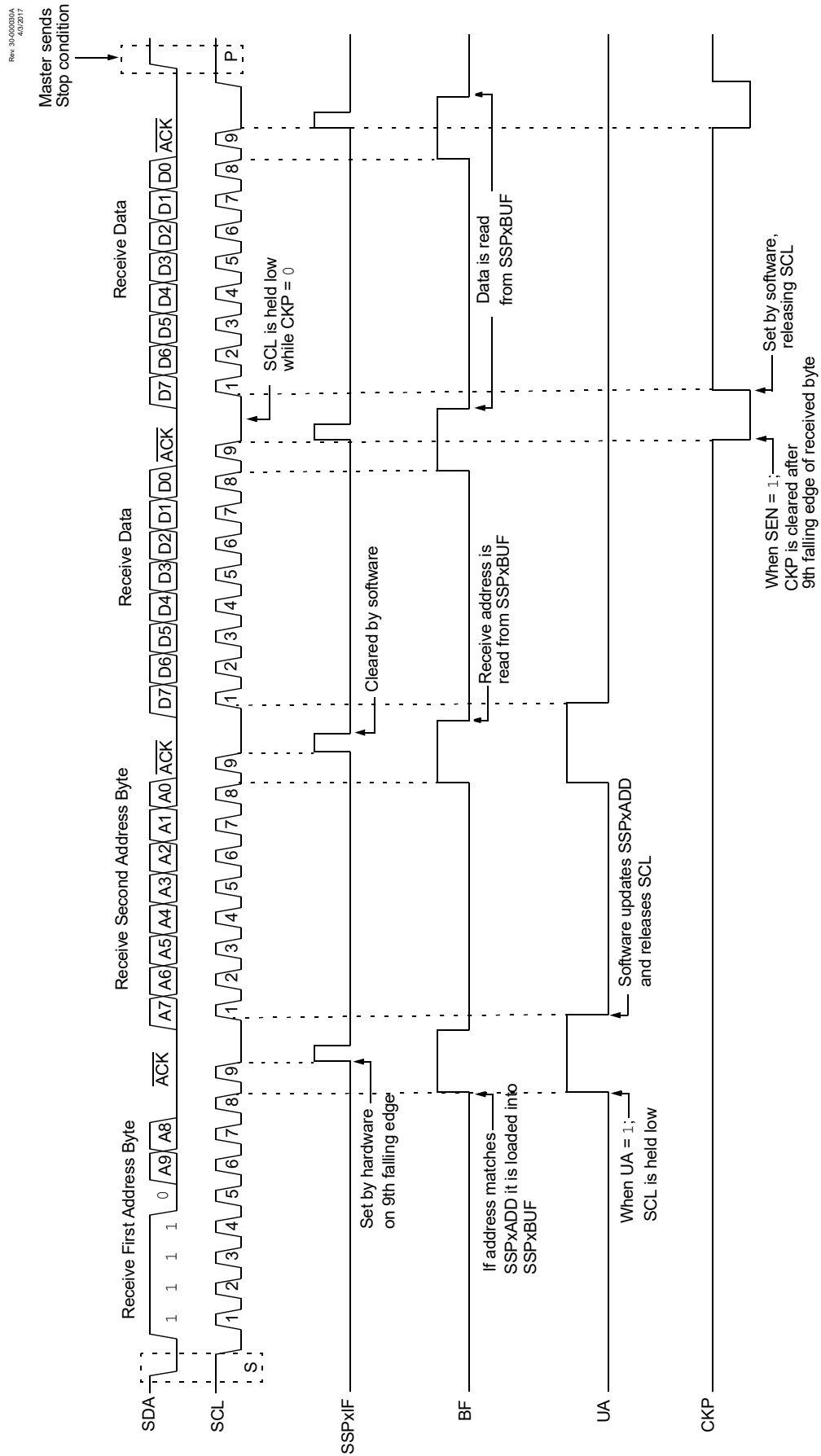


Figure 35-21. I<sup>2</sup>C Slave, 10-bit Address, Reception (SEN = 0, AHEN = 1, DHEN = 0)

Rev. 16-00001A  
4/2007

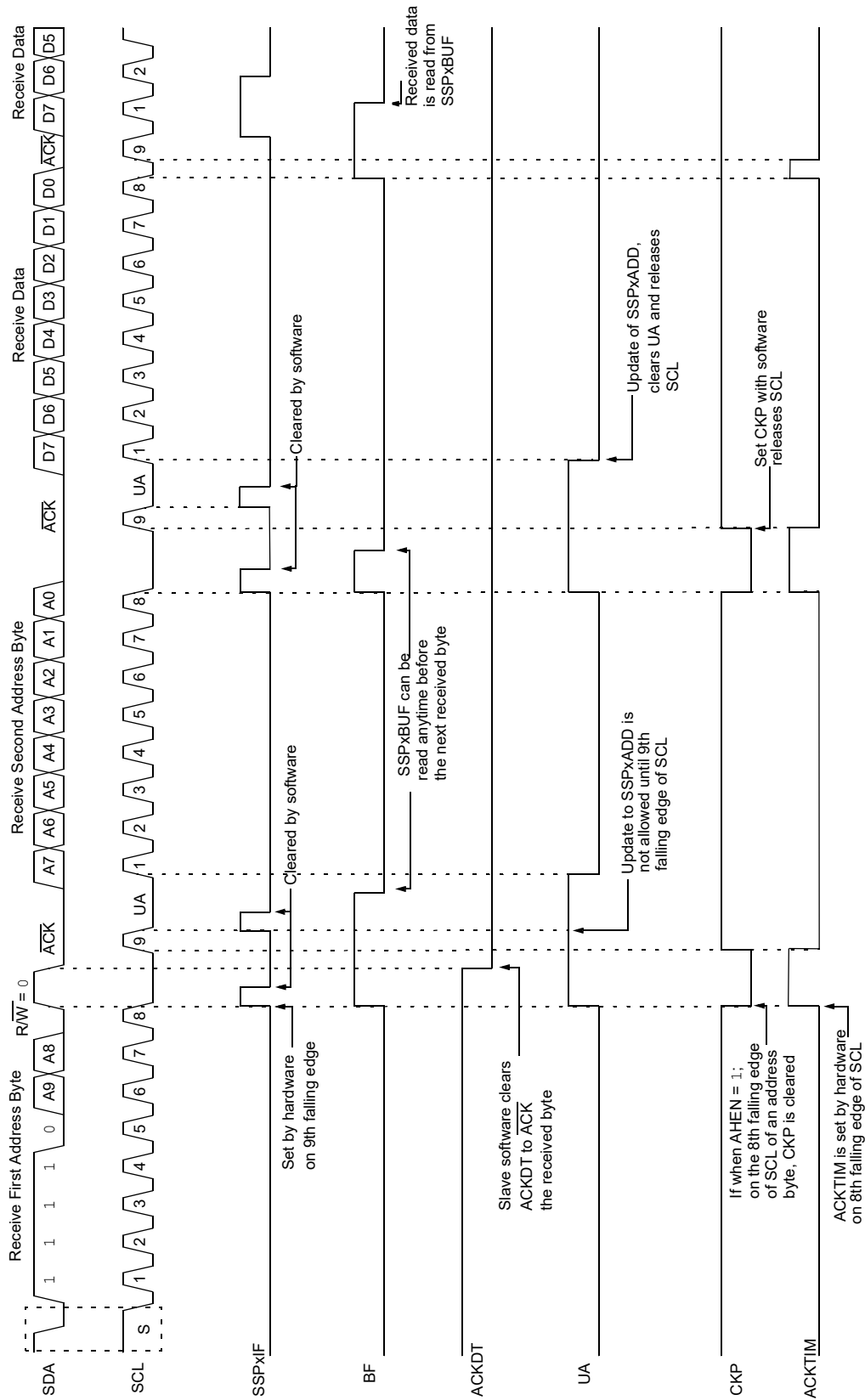
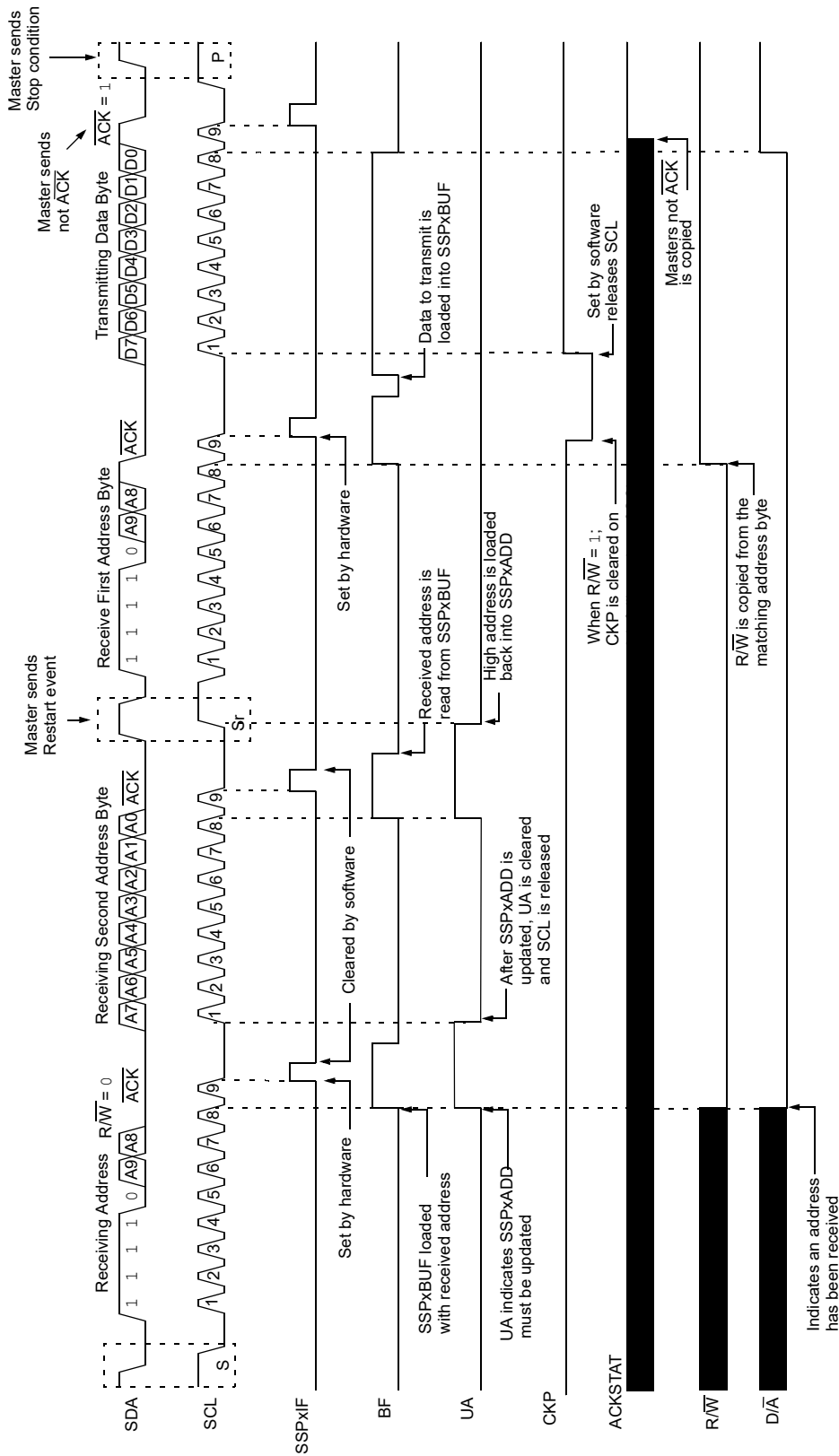


Figure 35-22. I<sup>2</sup>C Slave, 10-bit Address, Transmission (SEN = 0, AHEN = 0, DHEN = 0)

Rev. 30-00032A  
4/2017



### 35.5.6 Clock Stretching

Clock stretching occurs when a device on the bus holds the SCL line low, effectively pausing communication. The slave may stretch the clock to allow more time to handle data or prepare a response for the master device. A master device is not concerned with stretching as anytime it is active on the bus and not transferring data it is stretching. Any stretching done by a slave is invisible to the master software and handled by the hardware that generates SCL.

The **CKP** bit is used to control stretching in software. Any time the CKP bit is cleared, the module will wait for the SCL line to go low and then hold it. Setting CKP will release SCL and allow more communication.

#### 35.5.6.1 Normal Clock Stretching

Following an  $\overline{\text{ACK}}$  if the **R/W** bit is set, a read request, the slave hardware will clear CKP. This allows the slave time to update SSPxBUF with data to transfer to the master. If the **SEN** bit is set, the slave hardware will always stretch the clock after the  $\overline{\text{ACK}}$  sequence. Once the slave is ready; **CKP** is set by software and communication resumes.



**Important:**

1. The **BF** bit has no effect on if the clock will be stretched or not. This is different than previous versions of the module that would not stretch the clock, clear CKP, if SSPxBUF was read before the ninth falling edge of SCL.
2. Previous versions of the module did not stretch the clock for a transmission if SSPxBUF was loaded before the ninth falling edge of SCL. It is now always cleared for read requests.

#### 35.5.6.2 10-bit Addressing Mode

In 10-bit Addressing mode, when the **UA** bit is set, the clock is always stretched. This is the only time the SCL is stretched without CKP being cleared. SCL is released immediately after a write to SSPxADD.



**Important:** Previous versions of the module did not stretch the clock if the second address byte did not match.

#### 35.5.6.3 Byte NACKing

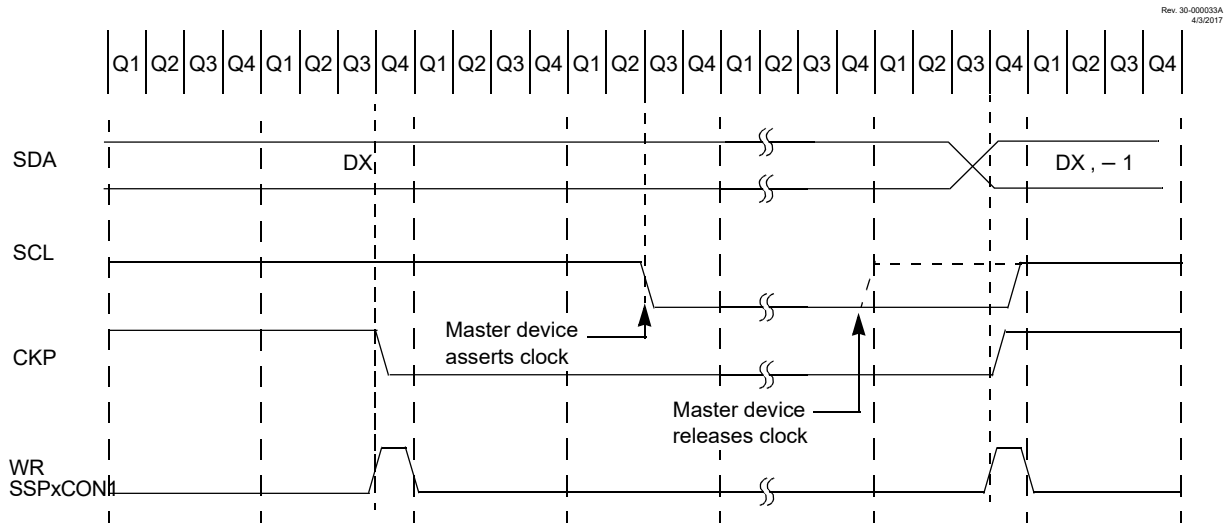
When the **AHEN** bit is set; CKP is cleared by hardware after the eighth falling edge of SCL for a received matching address byte. When the **DHEN** bit is set; CKP is cleared after the eighth falling edge of SCL for received data.

Stretching after the eighth falling edge of SCL allows the slave to look at the received address or data and decide if it wants to ACK the received data.

### 35.5.7 Clock Synchronization and the CKP bit

Any time the **CKP** bit is cleared, the module will wait for the SCL line to go low and then hold it. However, clearing the CKP bit will not assert the SCL output low until the SCL output is already sampled low. Therefore, the CKP bit will not assert the SCL line until an external I<sup>2</sup>C master device has already asserted the SCL line. The SCL output will remain low until the CKP bit is set and all other devices on the I<sup>2</sup>C bus have released SCL. This ensures that a write to the CKP bit will not violate the minimum high time requirement for SCL (see the following figure).

**Figure 35-23. Clock Synchronization Timing**

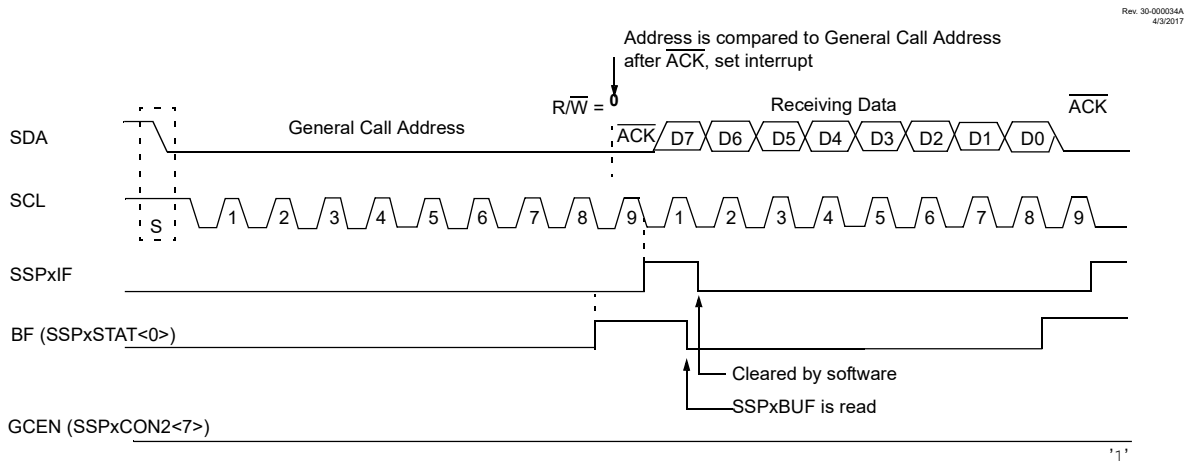


**35.5.8 General Call Address Support**

The addressing procedure for the I<sup>2</sup>C bus is such that the first byte after the Start condition usually determines which device will be the slave addressed by the master device. The exception is the general call address which can address all devices. When this address is used, all devices should, in theory, respond with an acknowledge.

The general call address is a reserved address in the I<sup>2</sup>C protocol, defined as address 0x00. When the GCEN bit is set, the slave module will automatically ACK the reception of this address regardless of the value stored in SSPxADD. After the slave clocks in an address of all zeros with the R/W bit clear, an interrupt is generated and slave software can read SSPxBUF and respond. The following figure shows a general call reception sequence.

**Figure 35-24. Slave Mode General Call Address Sequence**



In 10-bit Address mode, the UA bit will not be set on the reception of the general call address. The slave will prepare to receive the second byte as data, just as it would in 7-bit mode.



If the **AHEN** bit is set, just as with any other address reception, the slave hardware will stretch the clock after the eighth falling edge of SCL. The slave must then set its **ACKEN** value and release the clock with communication progressing as it would normally.

### 35.5.9 SSP Mask Register

An SSP Mask register (SSPxMSK) is available in I<sup>2</sup>C Slave mode as a mask for the value held in the SSPSR register during an address comparison operation. A zero ('0') bit in the SSPxMSK register has the effect of making the corresponding bit of the received address a "don't care".

This register is reset to all '1's upon any Reset condition and, therefore, has no effect on standard SSP operation until written with a mask value.

The SSP Mask register is active during:

- 7-bit Address mode: address compare of A<7:1>.
- 10-bit Address mode: address compare of A<7:0> only. The SSP mask has no effect during the reception of the first (high) byte of the address.

## 35.6 I<sup>2</sup>C Master Mode

Master mode is enabled by setting and clearing the appropriate **SSPM** bits and setting the **SSPEN** bit. In Master mode, the SDA and SCK pins must be configured as inputs. The MSSP peripheral hardware will override the output driver TRIS controls when necessary to drive the pins low.

Master mode of operation is supported by interrupt generation on the detection of the Start and Stop conditions. The Stop (**P**) and Start (**S**) bits are cleared from a Reset or when the MSSP module is disabled. Control of the I<sup>2</sup>C bus may be taken when the P bit is set, or the bus is Idle.

In Firmware Controlled Master mode, user code conducts all I<sup>2</sup>C bus operations based on Start and Stop bit condition detection. Start and Stop condition detection is the only active circuitry in this mode. All other communication is done by the user software directly manipulating the SDA and SCL lines.

The following events will cause the SSP Interrupt Flag bit, SSPxIF, to be set (SSP interrupt, if enabled):

- Start condition detected
- Stop condition detected
- Data transfer byte transmitted/received
- Acknowledge transmitted/received
- Repeated Start generated



#### Important:

1. The MSSP module, when configured in I<sup>2</sup>C Master mode, does not allow queuing of events. For instance, the user is not allowed to initiate a Start condition and immediately write the SSPxBUF register to initiate transmission before the Start condition is complete. In this case, the SSPxBUF will not be written to and the **WCOL** bit will be set, indicating that a write to the SSPxBUF did not occur.
  2. Master mode suspends Start/Stop detection when sending the Start/Stop condition by means of the SEN/PEN control bits. The SSPxIF bit is set at the end of the Start/Stop generation when hardware clears the control bit.
-

### 35.6.1 I<sup>2</sup>C Master Mode Operation

The master device generates all of the serial clock pulses and the Start and Stop conditions. A transfer is ended with a Stop condition or with a Repeated Start condition. Since the Repeated Start condition is also the beginning of the next serial transfer, the I<sup>2</sup>C bus will not be released.

In Master Transmitter mode, serial data is output through SDA, while SCL outputs the serial clock. The first byte transmitted contains the slave address of the receiving device (7 bits) and the R/W bit. In this case, the R/W bit will be logic '0'. Serial data is transmitted eight bits at a time. After each byte is transmitted, an Acknowledge bit is received. Start and Stop conditions are output to indicate the beginning and the end of a serial transfer.

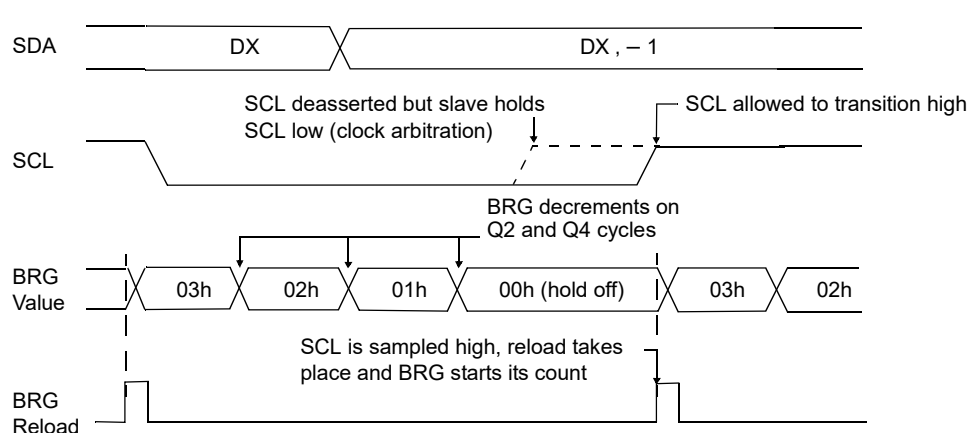
In Master Receive mode, the first byte transmitted contains the slave address of the transmitting device (7 bits) and the R/W bit. In this case, the R/W bit will be logic '1'. Thus, the first byte transmitted is a 7-bit slave address followed by a '1' to indicate the receive bit. Serial data is received via SDA, while SCL outputs the serial clock. Serial data is received eight bits at a time. After each byte is received, an Acknowledge bit is transmitted. Start and Stop conditions indicate the beginning and end of transmission.

A Baud Rate Generator is used to set the clock frequency output on SCL. See [35.7 Baud Rate Generator](#) for more detail.

### 35.6.2 Clock Arbitration

Clock arbitration occurs when the master, during any receive, transmit or Repeated Start/Stop condition, releases the SCL pin (SCL allowed to float high). When the SCL pin is allowed to float high, the Baud Rate Generator (BRG) is suspended from counting until the SCL pin is actually sampled high. When the SCL pin is sampled high, the Baud Rate Generator is reloaded with the contents of [35.9.6 SSPxADD](#) and begins counting. This ensures that the SCL high time will always be at least one BRG rollover count in the event that the clock is held low by an external device as shown in the following figure.

**Figure 35-25. Baud Rate Generator Timing with Clock Arbitration**



### 35.6.3 WCOL Status Flag

If the user writes the SSPxBUF when a Start, Restart, Stop, Receive or Transmit sequence is in progress, the WCOL bit is set and the contents of the buffer are unchanged (the write does not occur). Any time the WCOL bit is set it indicates that an action on SSPxBUF was attempted while the module was not idle.



**Important:** Because queuing of events is not allowed, writing to the lower five bits of SSPxCON2 is disabled until the Start condition is complete.

### 35.6.4 I<sup>2</sup>C Master Mode Start Condition Timing

To initiate a Start condition (Figure 35-26), the user sets the **SEN** Start Enable bit. If the SDA and SCL pins are sampled high, the Baud Rate Generator is reloaded with the contents of SSPxADD and starts its count. If SCL and SDA are both sampled high when the Baud Rate Generator times out ( $T_{BRG}$ ), the SDA pin is driven low. The action of the SDA being driven low while SCL is high is the Start condition and causes the **S** bit to be set. Following this, the Baud Rate Generator is reloaded with the contents of SSPxADD and resumes its count. When the Baud Rate Generator times out ( $T_{BRG}$ ), the **SEN** bit will be automatically cleared by hardware; the Baud Rate Generator is suspended, leaving the SDA line held low and the Start condition is complete.

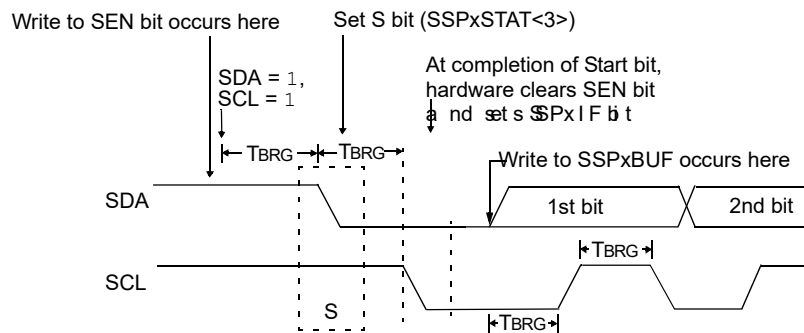


**Important:**

1. If at the beginning of the Start condition, the SDA and SCL pins are already sampled low, or if during the Start condition, the SCL line is sampled low before the SDA line is driven low, a bus collision occurs, the Bus Collision Interrupt Flag, BCLxIF, is set, the Start condition is aborted and the I<sup>2</sup>C module is reset into its Idle state.
2. The Philips I<sup>2</sup>C specification states that a bus collision cannot occur on a Start.

**Figure 35-26. First Start Bit Timing**

Rev. 30-000036A  
4/3/2017



### 35.6.5 I<sup>2</sup>C Master Mode Repeated Start Condition Timing

A Repeated Start condition (Figure 35-27) occurs when the **RSEN** bit is programmed high and the master state machine is no longer active. When the **RSEN** bit is set, the SCL pin is asserted low. When the SCL pin is sampled low, the Baud Rate Generator is loaded and begins counting. The SDA pin is released (brought high) for one Baud Rate Generator count ( $T_{BRG}$ ). When the Baud Rate Generator times out, if SDA is sampled high, the SCL pin will be deasserted (brought high). When SCL is sampled high, the Baud Rate Generator is reloaded and begins counting. SDA and SCL must be sampled high for one  $T_{BRG}$ . This action is then followed by assertion of the SDA pin ( $SDA = 0$ ) for one  $T_{BRG}$  while SCL is high. SCL is asserted low. Following this, the **RSEN** bit will be automatically cleared and the Baud Rate Generator will not be reloaded, leaving the SDA pin held low. As soon as a Start condition is detected on

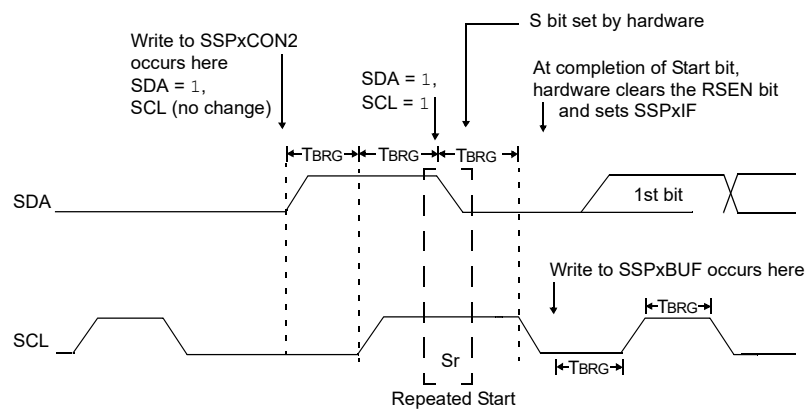
the SDA and SCL pins, the **S** bit will be set. The SSPxIF bit will not be set until the Baud Rate Generator has timed out.



**Important:**

1. If RSEN is programmed while any other event is in progress, it will not take effect.
2. A bus collision during the Repeated Start condition occurs if:
  - SDA is sampled low when SCL goes from low-to-high.
  - SCL goes low before SDA is asserted low. This may indicate that another master is attempting to transmit a data '1'.

**Figure 35-27. Repeated Start Condition Waveform**



Rev. 30-000037A  
4/10/2017

**35.6.6 I<sup>2</sup>C Master Mode Transmission**

Transmission of a data byte, a 7-bit address or the other half of a 10-bit address is accomplished by simply writing a value to the SSPxBUF register. This action will set the Buffer Full flag bit, BF, and allow the Baud Rate Generator to begin counting and start the next transmission. Each bit of address/data will be shifted out onto the SDA pin after the falling edge of SCL is asserted. SCL is held low for one Baud Rate Generator rollover count ( $T_{BRG}$ ). Data should be valid before SCL is released high. When the SCL pin is released high, it is held that way for  $T_{BRG}$ . The data on the SDA pin must remain stable for that duration and some hold time after the next falling edge of SCL. After the eighth bit is shifted out (the falling edge of the eighth clock), the BF flag is cleared and the master releases SDA. This allows the slave device being addressed to respond with an  $\overline{ACK}$  bit during the ninth bit time if an address match occurred, or if data was received properly. The status of  $\overline{ACK}$  is written into the **ACKSTAT** bit on the rising edge of the ninth clock. If the master receives an Acknowledge, the Acknowledge Status bit, ACKSTAT, is cleared. If not, the bit is set. After the ninth clock, the SSPxIF bit is set and the master clock (Baud Rate Generator) is suspended until the next data byte is loaded into the SSPxBUF, leaving SCL low and SDA unchanged (Figure 35-28).

After the write to the SSPxBUF, each bit of the address will be shifted out on the falling edge of SCL until all seven address bits and the  $R/\overline{W}$  bit are completed. On the falling edge of the eighth clock, the master will release the SDA pin, allowing the slave to respond with an Acknowledge. On the falling edge of the ninth clock, the master will sample the SDA pin to see if the address was recognized by a slave. The status of the  $\overline{ACK}$  bit is loaded into the ACKSTAT Status bit of the SSPxCON2 register. Following the falling edge of the ninth clock transmission of the address, the SSPxIF is set, the BF flag is cleared and

the Baud Rate Generator is turned off until another write to the SSPxBUF takes place, holding SCL low and allowing SDA to float.

#### **35.6.6.1 BF Status Flag**

In Transmit mode, the **BF** bit is set when the CPU writes to SSPxBUF and is cleared when all eight bits are shifted out.

#### **35.6.6.2 WCOL Status Flag**

If the user writes the SSPxBUF when a transmit is already in progress (i.e., SSPSR is still shifting out a data byte), the **WCOL** bit is set and the contents of the buffer are unchanged (the write does not occur).

The WCOL bit must be cleared by software before the next transmission.

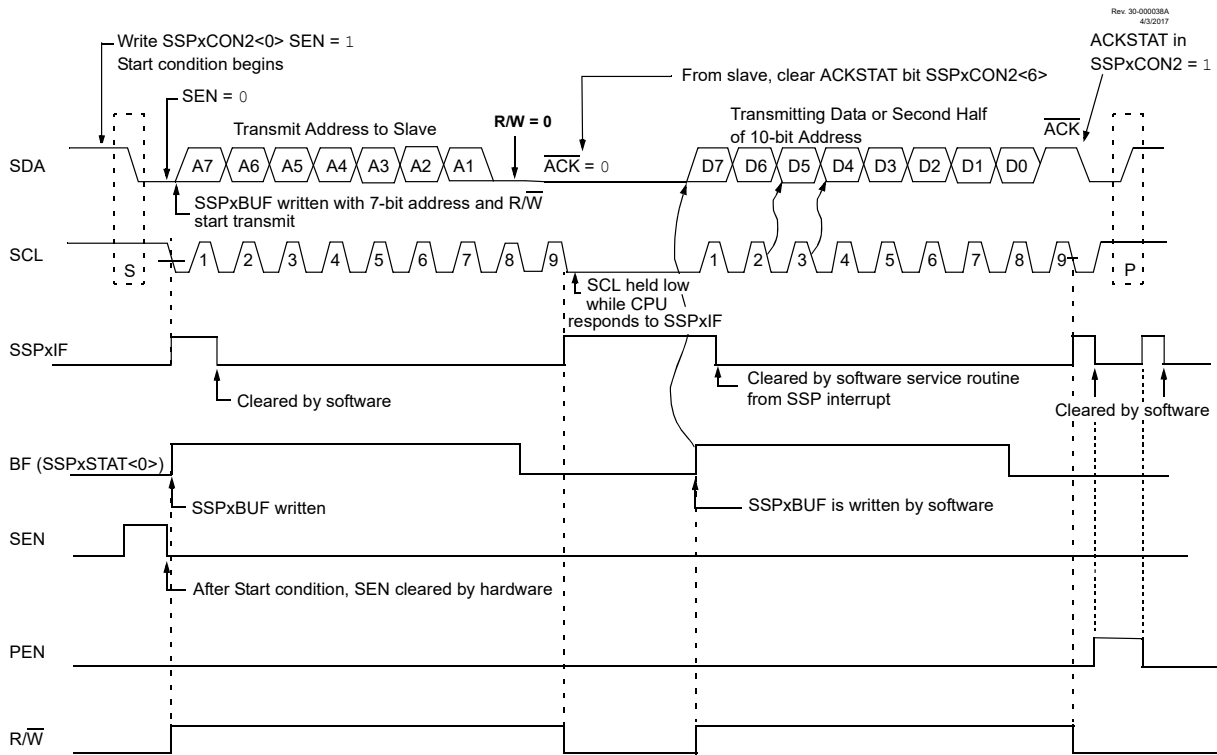
#### **35.6.6.3 ACKSTAT Status Flag**

In Transmit mode, the **ACKSTAT** bit is cleared when the slave has sent an Acknowledge ( $\overline{\text{ACK}} = 0$ ) and is set when the slave does not Acknowledge ( $\overline{\text{ACK}} = 1$ ). A slave sends an Acknowledge when it has recognized its address (including a general call), or when the slave has properly received its data.

#### **35.6.6.4 Typical transmit sequence:**

1. The user generates a Start condition by setting the **SEN** bit.
2. SSPxIF is set by hardware on completion of the Start.
3. SSPxIF is cleared by software.
4. The MSSP module will wait the required start time before any other operation takes place.
5. The user loads the SSPxBUF with the slave address to transmit.
6. Address is shifted out the SDA pin until all eight bits are transmitted. Transmission begins as soon as SSPxBUF is written to.
7. The MSSP module shifts in the  $\overline{\text{ACK}}$  bit from the slave device and writes its value into the **ACKSTAT** bit.
8. The MSSP module generates an interrupt at the end of the ninth clock cycle by setting the SSPxIF bit.
9. The user loads the SSPxBUF with eight bits of data.
10. Data is shifted out the SDA pin until all eight bits are transmitted.
11. The MSSP module shifts in the  $\overline{\text{ACK}}$  bit from the slave device and writes its value into the **ACKSTAT** bit.
12. Steps 8-11 are repeated for all transmitted data bytes.
13. The user generates a Stop or Restart condition by setting the **PEN** or **RSEN** bits. Interrupt is generated once the Stop/Restart condition is complete.

**Figure 35-28. I<sup>2</sup>C Master Mode Waveform (Transmission, 7 or 10-bit Address)**



### 35.6.7 I<sup>2</sup>C Master Mode Reception

Master mode reception (Figure 35-29) is enabled by programming the RCEN Receive Enable bit.



**Important:** The MSSP module must be in an Idle state before the RCEN bit is set or the RCEN bit will be disregarded.

The Baud Rate Generator begins counting and on each rollover, the state of the SCL pin changes (high-to-low/low-to-high) and data is shifted into the SSPSR. After the falling edge of the eighth clock all the following events occur:

- The receive enable flag is automatically cleared
- The contents of the SSPSR are loaded into the SSPxBUF
- The BF flag bit is set
- The SSPxIF bit is set
- The Baud Rate Generator is suspended from counting
- The SCL pin is held low

The MSSP is now in Idle state awaiting the next command. When the buffer is read by the CPU, the BF flag bit is automatically cleared. The user can then send an Acknowledge bit at the end of reception by setting the Acknowledge Sequence Enable, ACKEN bit.

#### 35.6.7.1 BF Status Flag

In receive operation, the BF bit is set when an address or data byte is loaded into SSPxBUF from SSPSR. It is cleared when the SSPxBUF register is read.

#### 35.6.7.2 SSPOV Status Flag

In receive operation, the **SSPOV** bit is set when eight bits are received into the SSPSR while the BF flag bit is already set from a previous reception.

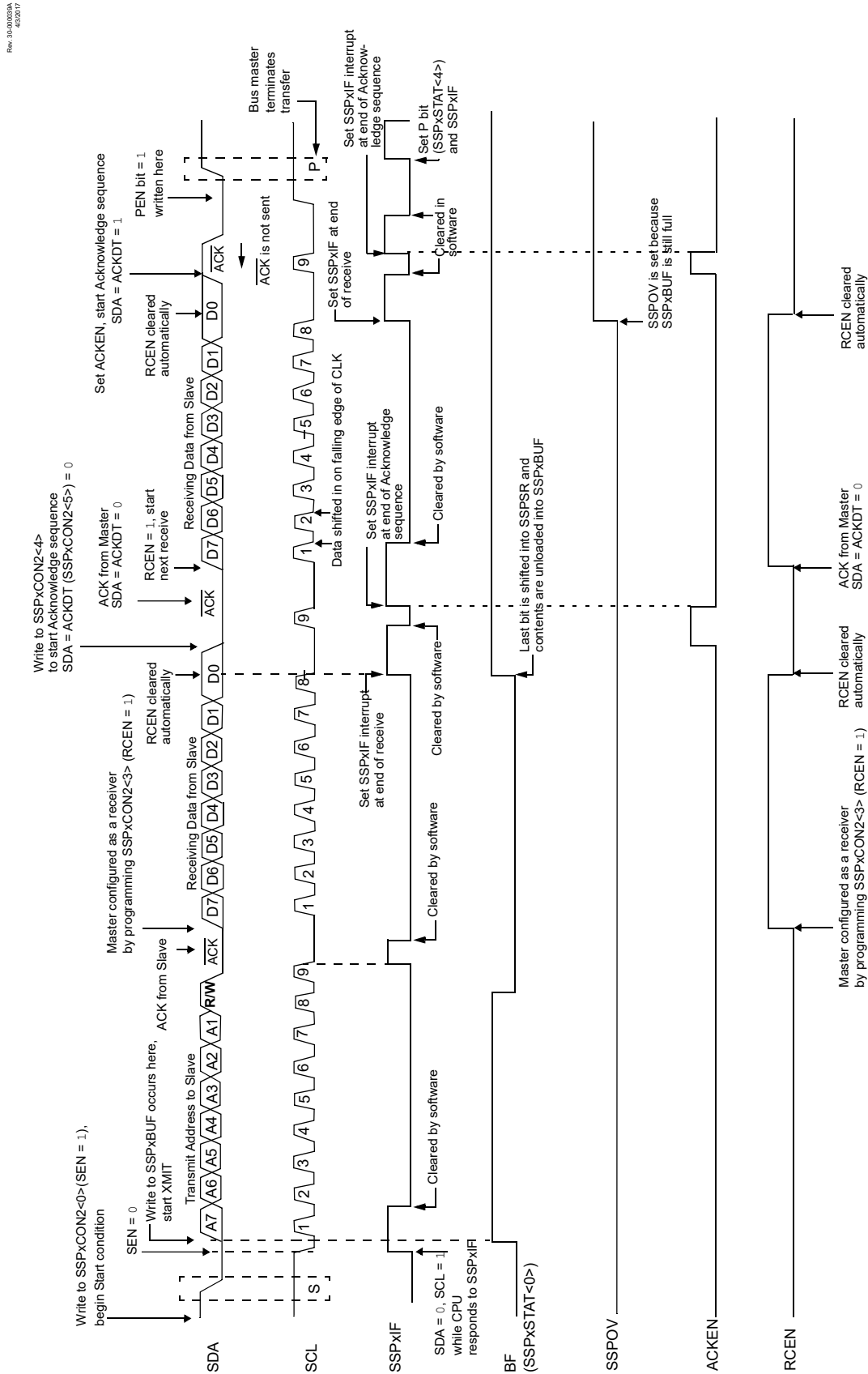
#### 35.6.7.3 WCOL Status Flag

If the user writes the SSPxBUF when a receive is already in progress (i.e., SSPSR is still shifting in a data byte), the **WCOL** bit is set and the contents of the buffer are unchanged (the write does not occur).

#### 35.6.7.4 Typical Receive Sequence:

1. The user generates a Start condition by setting the **SEN** bit.
2. SSPxIF is set by hardware on completion of the Start.
3. SSPxIF is cleared by software.
4. User writes SSPxBUF with the slave address to transmit and the **R/W** bit set.
5. Address is shifted out the SDA pin until all eight bits are transmitted. Transmission begins as soon as SSPxBUF is written to.
6. The MSSP module shifts in the  $\overline{\text{ACK}}$  bit from the slave device and writes its value into the **ACKSTAT** bit.
7. The MSSP module generates an interrupt at the end of the ninth clock cycle by setting the SSPxIF bit.
8. User sets the **RCEN** bit and the master clocks in a byte from the slave.
9. After the eighth falling edge of SCL, SSPxIF and BF are set.
10. Master clears SSPxIF and reads the received byte from SSPUF which clears BF.
11. Master sets the  $\overline{\text{ACK}}$  value to be sent to slave in the **ACKDT** bit and initiates the  $\overline{\text{ACK}}$  by setting the **ACKEN** bit.
12. Master's  $\overline{\text{ACK}}$  is clocked out to the slave and SSPxIF is set.
13. User clears SSPxIF.
14. Steps 8-13 are repeated for each received byte from the slave.
15. Master sends a not  $\overline{\text{ACK}}$  or Stop to end communication.

Figure 35-29. I<sup>2</sup>C Master Mode Waveform (Reception, 7-bit Address)

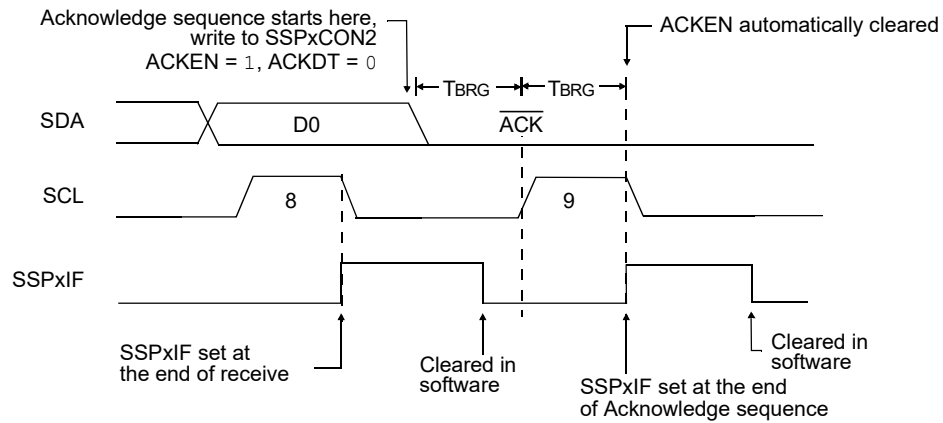




**35.6.8 Acknowledge Sequence Timing**

An Acknowledge sequence is enabled by setting the Acknowledge Sequence Enable **ACKEN** bit. When this bit is set, the SCL pin is pulled low and the contents of the Acknowledge data bit are presented on the SDA pin. If the user wishes to generate an Acknowledge, then the **ACKDT** bit should be cleared. If not, the user should set the **ACKDT** bit before starting an Acknowledge sequence. The Baud Rate Generator then counts for one rollover period ( $T_{BRG}$ ) and the SCL pin is deasserted (pulled high). When the SCL pin is sampled high (clock arbitration), the Baud Rate Generator counts for  $T_{BRG}$ . The SCL pin is then pulled low. Following this, the **ACKEN** bit is automatically cleared, the Baud Rate Generator is turned off and the MSSP module then goes into Idle mode.

**Figure 35-30. Acknowledge Sequence Waveform**



**Note:**  $T_{BRG}$  = one Baud Rate Generator period.

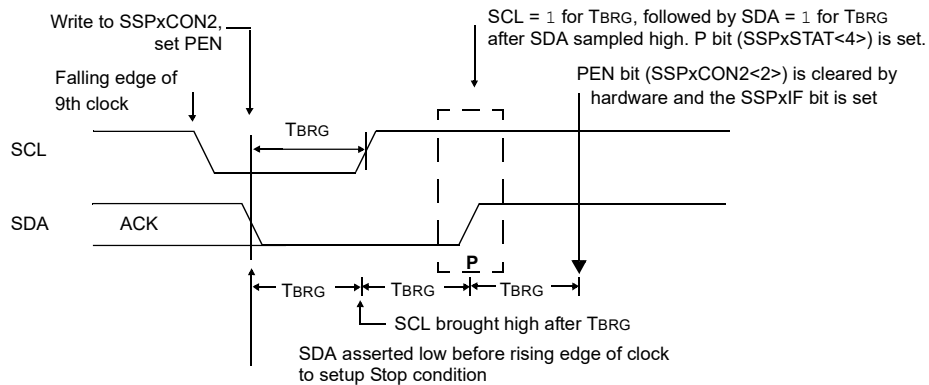
**35.6.8.1 Acknowledge Write Collision**

If the user writes the **SSPxBUF** when an Acknowledge sequence is in progress, then the **WCOL** bit is set and the contents of the buffer are unchanged (the write does not occur).

**35.6.9 Stop Condition Timing**

A Stop bit is asserted on the SDA pin at the end of a receive/transmit by setting the Stop Sequence Enable **PEN** bit. At the end of a receive/transmit, the SCL line is held low after the falling edge of the ninth clock. When the **PEN** bit is set, the master will assert the SDA line low. When the SDA line is sampled low, the Baud Rate Generator is reloaded and counts down to '0'. When the Baud Rate Generator times out, the SCL pin will be brought high and one  $T_{BRG}$  (Baud Rate Generator rollover count) later, the SDA pin will be deasserted. When the SDA pin is sampled high while SCL is high, the **P** bit is set. One  $T_{BRG}$  later, the **PEN** bit is cleared and the **SSPxIF** bit is set.

**Figure 35-31. Stop Condition in Receive or Transmit Mode**



**Note:** TBRG = one Baud Rate Generator period.

### 35.6.9.1 Write Collision on Stop

If the user writes the SSPxBUF when a Stop sequence is in progress, then the WCOL bit is set and the contents of the buffer are unchanged (the write does not occur).

### 35.6.10 Sleep Operation

While in Sleep mode, the I<sup>2</sup>C slave module can receive addresses or data and when an address match or complete byte transfer occurs, wake the processor from Sleep (if the MSSP interrupt is enabled).

### 35.6.11 Effects of a Reset

A Reset disables the MSSP module and terminates the current transfer.

### 35.6.12 Multi-Master Mode

In Multi-Master mode, the interrupt generation on the detection of the Start and Stop conditions allows the determination of when the bus is free. The Stop (P) and Start (S) bits are cleared from a Reset or when the MSSP module is disabled. Control of the I<sup>2</sup>C bus may be taken when the P bit is set, or the bus is Idle, with both the S and P bits clear. When the bus is busy, enabling the SSP interrupt will generate the interrupt when the Stop condition occurs.

In multi-master operation, the SDA line must be monitored for arbitration to see if the signal level is the expected output level. This check is performed by hardware with the result placed in the BCLxIF bit.

The states where arbitration can be lost are:

- Address Transfer
- Data Transfer
- A Start Condition
- A Repeated Start Condition
- An Acknowledge Condition

### 35.6.13 Multi -Master Communication, Bus Collision and Bus Arbitration

Multi-Master mode support is achieved by bus arbitration. When the master outputs address/data bits onto the SDA pin, arbitration takes place when the master outputs a '1' on SDA, by letting SDA float high and another master asserts a '0'. When the SCL pin floats high, data should be stable. If the expected data on SDA is a '1' and the data sampled on the SDA pin is '0', then a bus collision has taken place. The master will set the Bus Collision Interrupt Flag, BCLxIF and reset the I<sup>2</sup>C port to its Idle state (Figure 35-32).

If a transmit was in progress when the bus collision occurred, the transmission is halted, the BF flag is cleared, the SDA and SCL lines are deasserted and the SSPxBUF can be written to. When the user services the bus collision Interrupt Service Routine and if the I<sup>2</sup>C bus is free, the user can resume communication by asserting a Start condition.

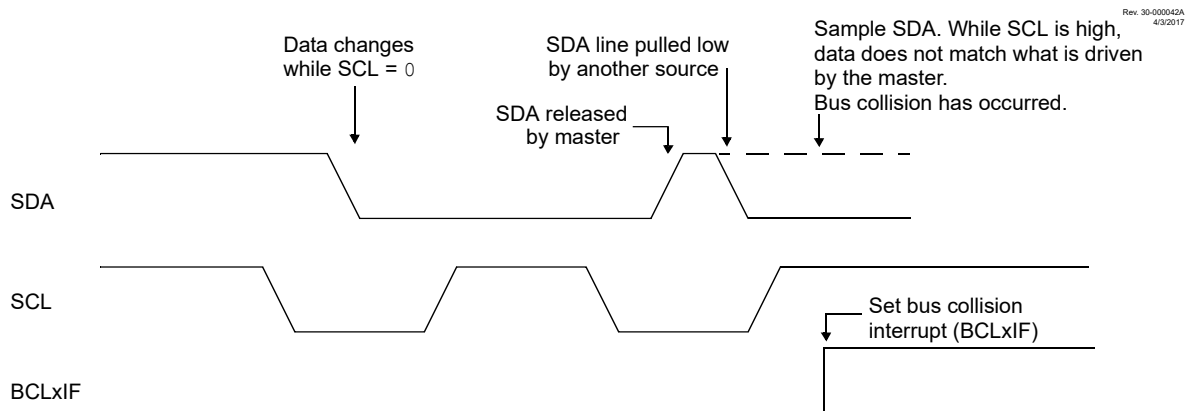
If a Start, Repeated Start, Stop or Acknowledge condition was in progress when the bus collision occurred, the condition is aborted, the SDA and SCL lines are deasserted and the respective control bits in the SSPxCON2 register are cleared. When the user services the bus collision Interrupt Service Routine and if the I<sup>2</sup>C bus is free, the user can resume communication by asserting a Start condition.

The master will continue to monitor the SDA and SCL pins. If a Stop condition occurs, the SSPxIF bit will be set.

A write to the SSPxBUF will start the transmission of data at the first data bit, regardless of where the transmitter left off when the bus collision occurred.

In Multi-Master mode, the interrupt generation on the detection of Start and Stop conditions allows the determination of when the bus is free. Control of the I<sup>2</sup>C bus can be taken when the P bit is set, or the bus is Idle and the S and P bits are cleared.

**Figure 35-32. Bus Collision Timing for Transmit and Acknowledge**



### 35.6.13.1 Bus Collision During a Start Condition

During a Start condition, a bus collision occurs if:

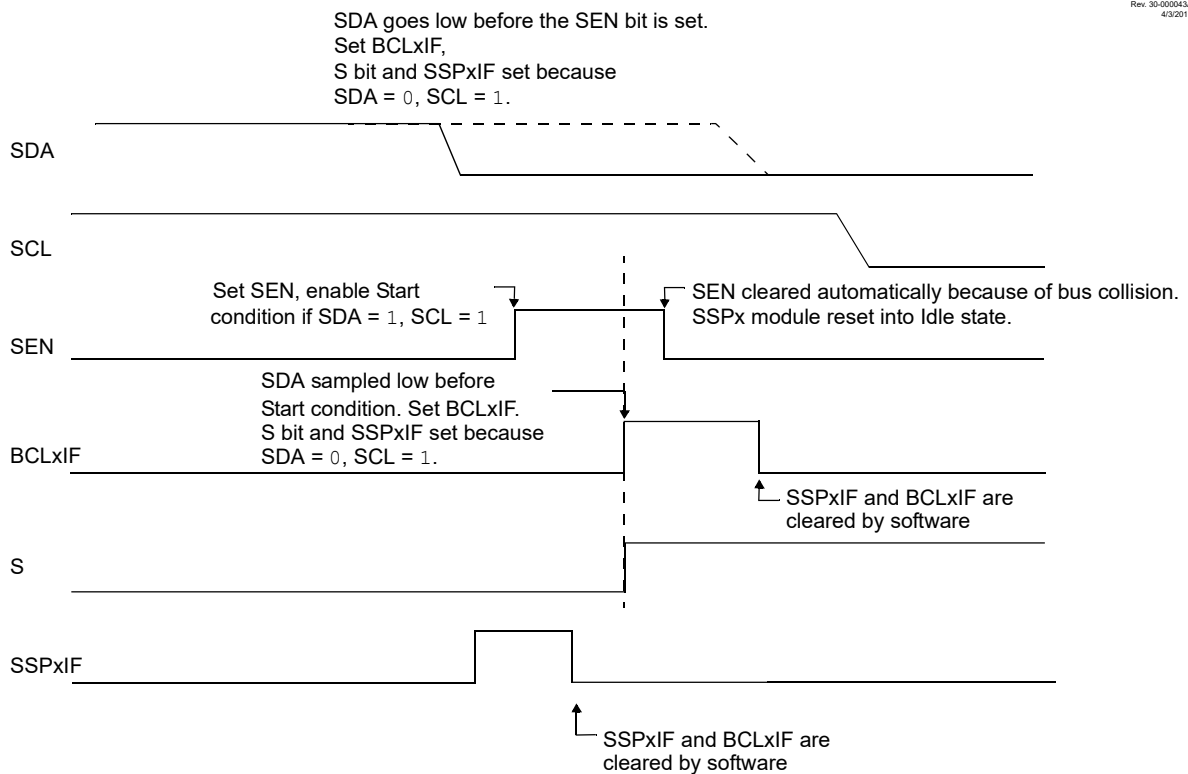
1. SDA or SCL are sampled low at the beginning of the Start condition (Figure 35-33).
2. SCL is sampled low before SDA is asserted low (Figure 35-34).

During a Start condition, both the SDA and the SCL pins are monitored.

If the SDA pin is already low, or the SCL pin is already low, then all of the following occur:

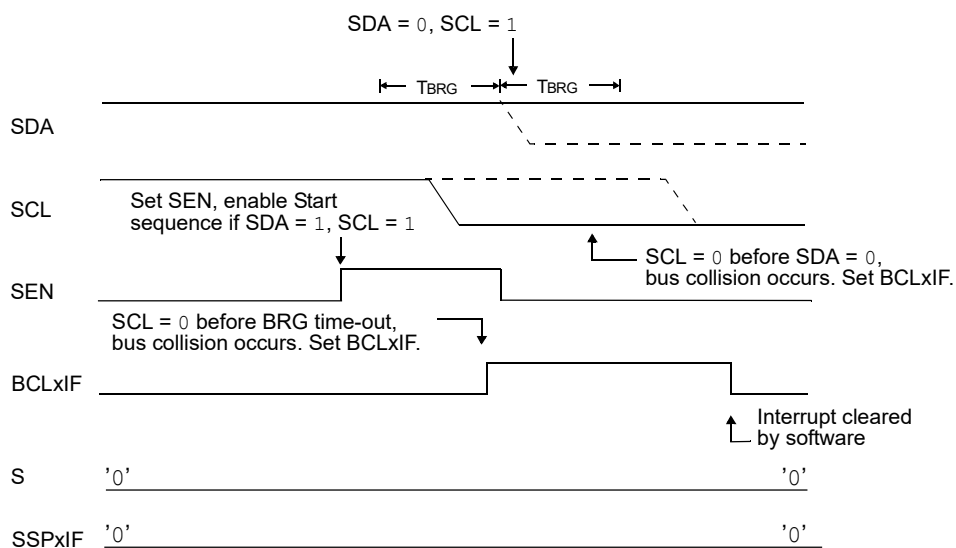
- the Start condition is aborted,
- the BCLxIF flag is set and
- the MSSP module is reset to its Idle state (Figure 35-33).

**Figure 35-33. Bus Collision During Start Condition (SDA Only)**



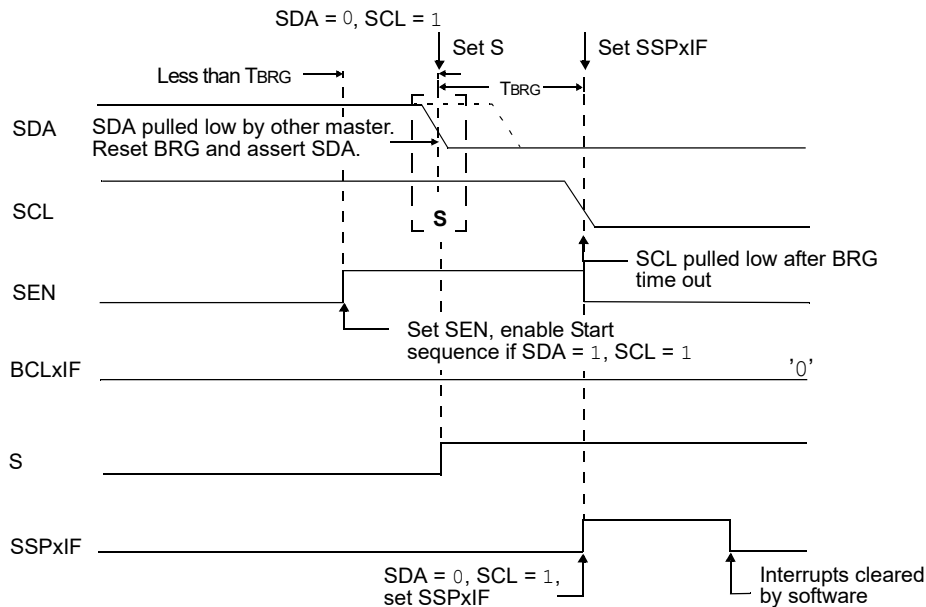
The Start condition begins with the SDA and SCL pins deasserted. When the SDA pin is sampled high, the Baud Rate Generator is loaded and counts down. If the SCL pin is sampled low while SDA is high, a bus collision occurs because it is assumed that another master is attempting to drive a data '1' during the Start condition.

**Figure 35-34. Bus Collision During Start Condition (SCL = 0)**



If the SDA pin is sampled low during this count, the BRG is reset and the SDA line is asserted early (Figure 35-35). If, however, a '1' is sampled on the SDA pin, the SDA pin is asserted low at the end of the BRG count. The Baud Rate Generator is then reloaded and counts down to zero; if the SCL pin is sampled as '0' during this time, a bus collision does not occur. At the end of the BRG count, the SCL pin is asserted low.

**Figure 35-35. BRG Reset Due to SDA Arbitration During Start Condition**



**Important:** The reason that bus collision is not a factor during a Start condition is that no two bus masters can assert a Start condition at the exact same time. Therefore, one master will always assert SDA before the other. This condition does not cause a bus collision because the two masters must be allowed to arbitrate the first address following the Start condition. If the address is the same, arbitration must be allowed to continue into the data portion, Repeated Start or Stop conditions.

### 35.6.13.2 Bus Collision During a Repeated Start Condition

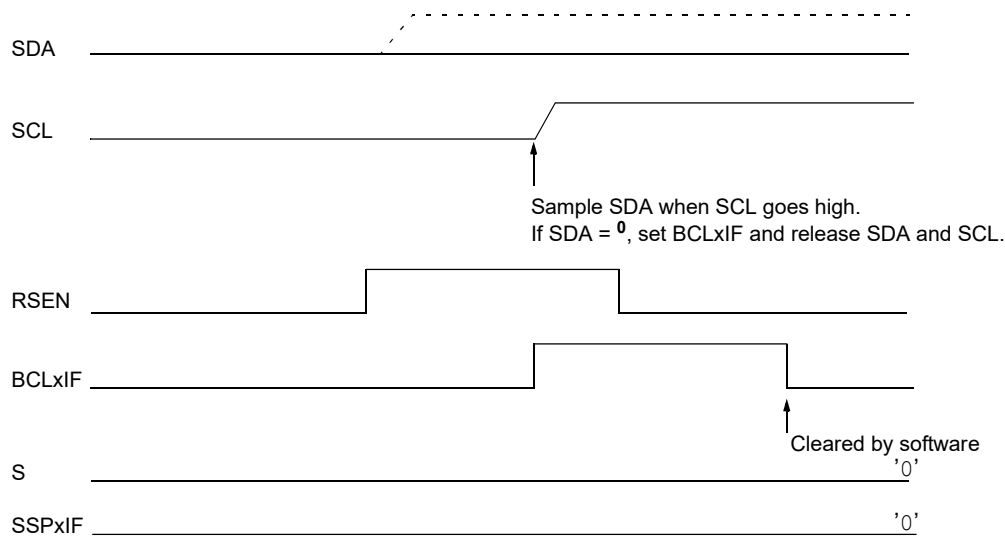
During a Repeated Start condition, a bus collision occurs if:

1. A low level is sampled on SDA when SCL goes from low level to high level (Case 1).
2. SCL goes low before SDA is asserted low, indicating that another master is attempting to transmit a data '1' (Case 2).

When the user releases SDA and the pin is allowed to float high, the BRG is loaded with SSPxADD and counts down to zero. The SCL pin is then deasserted and when sampled high, the SDA pin is sampled.

If SDA is low, a bus collision has occurred (i.e., another master is attempting to transmit a data '0', Figure 35-36). If SDA is sampled high, the BRG is reloaded and begins counting. If SDA goes from high-to-low before the BRG times out, no bus collision occurs because no two masters can assert SDA at exactly the same time.

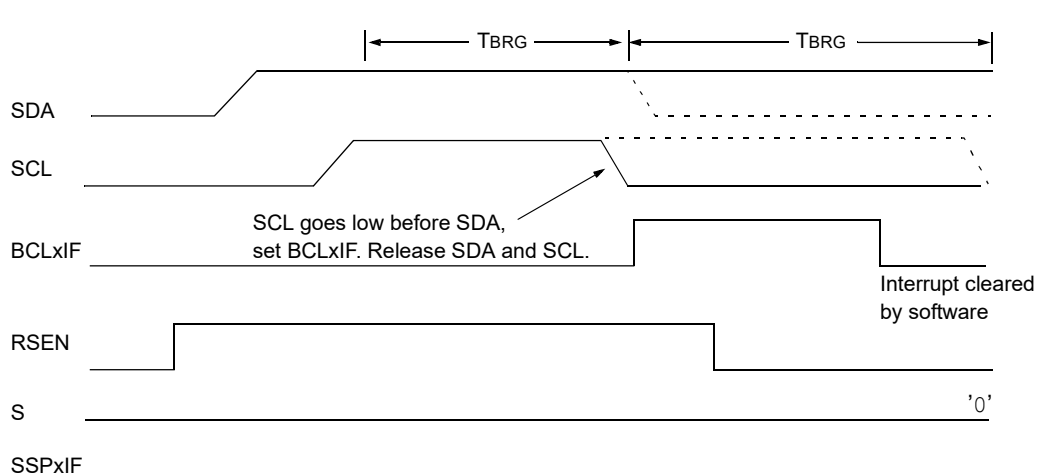
**Figure 35-36. Bus Collision During a Repeated Start Condition (Case 1)**



If SCL goes from high-to-low before the BRG times out and SDA has not already been asserted, a bus collision occurs. In this case, another master is attempting to transmit a data '1' during the Repeated Start condition, see [Figure 35-37](#).

If, at the end of the BRG time out, both SCL and SDA are still high, the SDA pin is driven low and the BRG is reloaded and begins counting. At the end of the count, regardless of the status of the SCL pin, the SCL pin is driven low and the Repeated Start condition is complete.

**Figure 35-37. Bus Collision During Repeated Start Condition (Case 2)**



### 35.6.13.3 Bus Collision During a Stop Condition

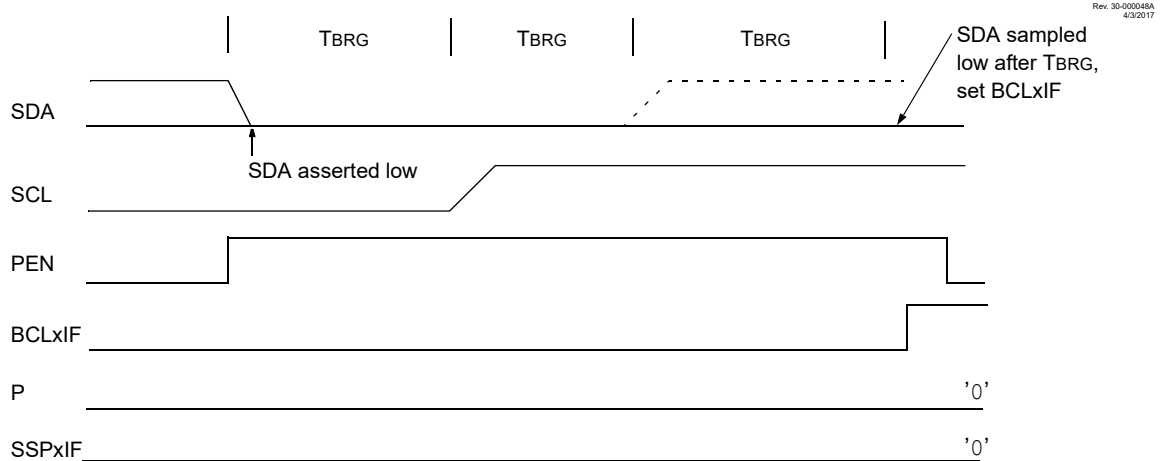
Bus collision occurs during a Stop condition if:

1. After the SDA pin has been deasserted and allowed to float high, SDA is sampled low after the BRG has timed out (Case 1).
2. After the SCL pin is deasserted, SCL is sampled low before SDA goes high (Case 2).

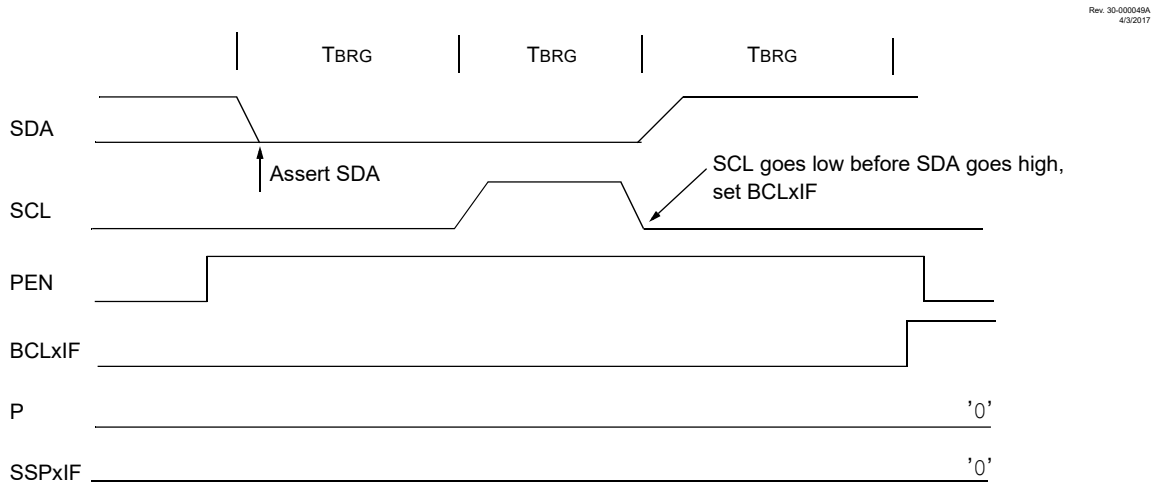
The Stop condition begins with SDA asserted low. When SDA is sampled low, the SCL pin is allowed to float. When the pin is sampled high (clock arbitration), the Baud Rate Generator is loaded with SSPxADD

and counts down to zero. After the BRG times out, SDA is sampled. If SDA is sampled low, a bus collision has occurred. This is due to another master attempting to drive a data '0' (Figure 35-38). If the SCL pin is sampled low before SDA is allowed to float high, a bus collision occurs. This is another case of another master attempting to drive a data '0' (Figure 35-39).

**Figure 35-38. Bus Collision During a Stop Condition (Case 1)**



**Figure 35-39. Bus Collision During a Stop Condition (Case 2)**



### 35.7 Baud Rate Generator

The MSSP module has a Baud Rate Generator available for clock generation in both I<sup>2</sup>C and SPI Master modes. The Baud Rate Generator (BRG) reload value is placed in the SSPxADD register. When a write occurs to SSPxBUF, the Baud Rate Generator will automatically begin counting down.

Once the given operation is complete, the internal clock will automatically stop counting and the clock pin will remain in its last state.

An internal signal "Reload" shown in Figure 35-40 triggers the value from SSPxADD to be loaded into the BRG counter. This occurs twice for each oscillation of the module clock line. The logic dictating when the reload signal is asserted depends on the mode in which the MSSP is being operated.

# PIC16(L)F18455/56

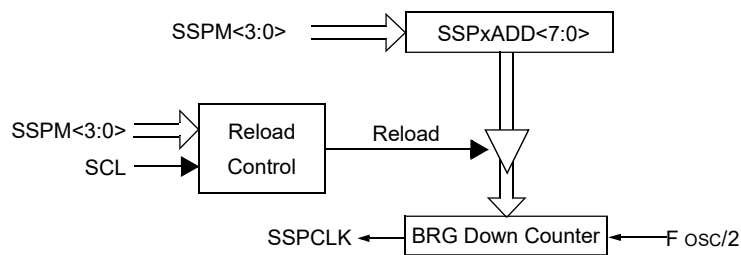
## (MSSP) Master Synchronous Serial Port Module

Table 35-1 illustrates clock rates based on instruction cycles and the BRG value loaded into SSPxADD.

### Example 35-1. MSSP Baud Rate Generator Frequency Equation

$$F_{CLOCK} = \frac{F_{OSC}}{4 \times (SSPxADD + 1)}$$

Figure 35-40. Baud Rate Generator Block Diagram



**Important:** Values of 0x00, 0x01 and 0x02 are not valid for SSPxADD when used as a Baud Rate Generator for I<sup>2</sup>C. This is an implementation limitation.

Table 35-1. MSSP Clock Rate w/BRG

F <sub>OSC</sub>	F <sub>CY</sub>	BRG Value	F <sub>CLOCK</sub> (2 Rollovers of BRG)
32 MHz	8 MHz	13h	400 kHz
32 MHz	8 MHz	19h	308 kHz
32 MHz	8 MHz	4Fh	100 kHz
16 MHz	4 MHz	09h	400 kHz
16 MHz	4 MHz	0Ch	308 kHz
16 MHz	4 MHz	27h	100 kHz
4 MHz	1 MHz	09h	100 kHz

**Note:** Refer to the I/O port electrical specifications in the "Electrical Specifications" section, Internal Oscillator Parameters, to ensure the system is designed to support IOL requirements.



# PIC16(L)F18455/56

## (MSSP) Master Synchronous Serial Port Module

### 35.8 Register Summary: MSSP Control

Address	Name	Bit Pos.									
0x018C	SSP1BUF	7:0	BUF[7:0]								
0x018D	SSP1ADD	7:0	ADD[7:0]								
0x018E	SSP1MSK	7:0	MSK[6:0]								MSK0
0x018F	SSP1STAT	7:0	SMP	CKE	D/A	P	S	R/W	UA	BF	
0x0190	SSP1CON1	7:0	WCOL	SSPOV	SSPEN	CKP	SSPM[3:0]				
0x0191	SSP1CON2	7:0	GCEN	ACKSTAT	ACKDT	ACKEN	RCEN	PEN	RSEN	SEN	
0x0192	SSP1CON3	7:0	ACKTIM	PCIE	SCIE	BOEN	SDAHT	SBCDE	AHEN	DHEN	
0x0193 ... 0x0195	Reserved										
0x0196	SSP2BUF	7:0	BUF[7:0]								
0x0197	SSP2ADD	7:0	ADD[7:0]								
0x0198	SSP2MSK	7:0	MSK[6:0]								MSK0
0x0199	SSP2STAT	7:0	SMP	CKE	D/A	P	S	R/W	UA	BF	
0x019A	SSP2CON1	7:0	WCOL	SSPOV	SSPEN	CKP	SSPM[3:0]				
0x019B	SSP2CON2	7:0	GCEN	ACKSTAT	ACKDT	ACKEN	RCEN	PEN	RSEN	SEN	
0x019C	SSP2CON3	7:0	ACKTIM	PCIE	SCIE	BOEN	SDAHT	SBCDE	AHEN	DHEN	

### 35.9 Register Definitions: MSSP Control

# PIC16(L)F18455/56

## (MSSP) Master Synchronous Serial Port Module

### 35.9.1 SSPxSTAT

**Name:** SSPxSTAT  
**Address:** 0x18F,0x199

MSSP Status Register

Bit	7	6	5	4	3	2	1	0
	SMP	CKE	D/A	P	S	R/W	UA	BF
Access	R/W	R/W	RO	RO	RO	RO	RO	RO
Reset	0	0	0	0	0	0	0	0

#### Bit 7 – SMP Slew Rate Control bit

Value	Mode	Description
1	SPI Master	Input data is sampled at the end of data output time
0	SPI Master	Input data is sampled at the middle of data output time
0	SPI Slave	Keep this bit cleared in SPI Slave mode
1	I <sup>2</sup> C	Slew rate control is disabled for Standard Speed mode (100 kHz and 1 MHz)
0	I <sup>2</sup> C	Slew rate control is enabled for High-Speed mode (400 kHz)

#### Bit 6 – CKE

SPI: Clock select bit<sup>(4)</sup> I<sup>2</sup>C: SMBus Select bit

Value	Mode	Description
1	SPI	Transmit occurs on the transition from active to Idle clock state
0	SPI	Transmit occurs on the transition from Idle to active clock state
1	I <sup>2</sup> C	Enables SMBus-specific inputs
0	I <sup>2</sup> C	Disables SMBus-specific inputs

#### Bit 5 – D/A

Data/Address bit

Value	Mode	Description
x	SPI or I <sup>2</sup> C Master	Reserved
1	I <sup>2</sup> C Slave	Indicates that the last byte received or transmitted was data
0	I <sup>2</sup> C Slave	Indicates that the last byte received or transmitted was address

#### Bit 4 – P

Stop bit<sup>(1)</sup>

Value	Mode	Description
x	SPI	Reserved
1	I <sup>2</sup> C	Stop bit was detected last
0	I <sup>2</sup> C	Stop bit was not detected last

#### Bit 3 – S

Start bit<sup>(1)</sup>

# PIC16(L)F18455/56

## (MSSP) Master Synchronous Serial Port Module

Value	Mode	Description
x	SPI	Reserved
1	I <sup>2</sup> C	Start bit was detected last
0	I <sup>2</sup> C	Start bit was not detected last

### Bit 2 – R/W

Read/Write Information bit<sup>(2,3)</sup>

Value	Mode	Description
x	SPI	Reserved
1	I <sup>2</sup> C Slave	Read
0	I <sup>2</sup> C Slave	Write
1	I <sup>2</sup> C Master	Transmit is in progress
0	I <sup>2</sup> C Master	Transmit is not in progress

### Bit 1 – UA Update Address bit (10-Bit Slave mode only)

Value	Mode	Description
x	All other modes	Reserved
1	I <sup>2</sup> C 10-bit Slave	Indicates that the user needs to update the address in the SSPxADD register
0	I <sup>2</sup> C 10-bit Slave	Address does not need to be updated

### Bit 0 – BF

Buffer Full Status bit<sup>(5)</sup>

Value	Mode	Description
1	I <sup>2</sup> C Transmit	Character written to SSPxBUF has not been sent
0	I <sup>2</sup> C Transmit	SSPxBUF is ready for next character
1	SPI and I <sup>2</sup> C Receive	Received character in SSPxBUF has not been read
0	SPI and I <sup>2</sup> C Receive	Received character in SSPxBUF has been read

#### Note:

1. This bit is cleared on Reset and when **SSPEN** is cleared.
2. In I<sup>2</sup>C Slave mode this bit holds the R/W bit information following the last address match. This bit is only valid from the address match to the next Start bit, Stop bit or not  $\overline{\text{ACK}}$  bit.
3. ORing this bit with SEN, RSEN, PEN, RCEN or ACKEN will indicate if the MSSP is in Active mode.
4. Polarity of clock state is set by the **CKP** bit.
5. I<sup>2</sup>C receive status does not include  $\overline{\text{ACK}}$  and Stop bits.

# PIC16(L)F18455/56

## (MSSP) Master Synchronous Serial Port Module

### 35.9.2 SSPxCON1

**Name:** SSPxCON1  
**Address:** 0x190,0x19A

MSSP Control Register 1

Bit	7	6	5	4	3	2	1	0
	WCOL	SSPOV	SSPEN	CKP	SSPM[3:0]			
Access	R/W/HS	R/W/HS	R/W	R/W	R/W	R/W	R/W	R/W
Reset	0	0	0	0	0	0	0	0

#### Bit 7 – WCOL

Write Collision Detect bit

Value	Mode	Description
1	SPI	A write to the SSPxBUF register was attempted while the previous byte was still transmitting (must be cleared by software)
1	I <sup>2</sup> C Master transmit	A write to the SSPxBUF register was attempted while the I <sup>2</sup> C conditions were not valid for a transmission to be started (must be cleared by software)
1	I <sup>2</sup> C Slave transmit	The SSPxBUF register is written while it is still transmitting the previous word (must be cleared in software)
0	SPI or I <sup>2</sup> C Master or Slave transmit	No collision
x	Master or Slave receive	Don't care

#### Bit 6 – SSPOV

Receive Overflow Indicator bit<sup>(1)</sup>

Value	Mode	Description
1	SPI Slave	A byte is received while the SSPxBUF register is still holding the previous byte. The user must read SSPxBUF, even if only transmitting data, to avoid setting overflow. (must be cleared in software)
1	I <sup>2</sup> C Receive	A byte is received while the SSPxBUF register is still holding the previous byte (must be cleared in software)
0	SPI Slave or I <sup>2</sup> C Receive	No overflow
x	SPI Master or I <sup>2</sup> C Master transmit	Don't care

#### Bit 5 – SSPEN

Master Synchronous Serial Port Enable bit.<sup>(2)</sup>

# PIC16(L)F18455/56

## (MSSP) Master Synchronous Serial Port Module

Value	Mode	Description
1	SPI	Enables the serial port. The SCKx, SDOx, SDIx, and $\overline{SSx}$ pin selections must be made with the PPS controls. Each signal must be configured with the corresponding TRIS control to the direction appropriate for the mode selected.
1	I <sup>2</sup> C	Enables the serial port. The SDAX and SCLx pin selections must be made with the PPS controls. Since both signals are bidirectional the PPS input pin and PPS output pin selections must be made that specify the same pin. Both pins must be configured as inputs with the corresponding TRIS controls.
0	All	Disables serial port and configures these pins as I/O port pins

### Bit 4 – CKP

SCK Release Control bit

Value	Mode	Description
1	SPI	Idle state for the clock is a high level
0	SPI	Idle state for the clock is a low level
1	I <sup>2</sup> C Slave	Releases clock
0	I <sup>2</sup> C Slave	Holds clock low (clock stretch), used to ensure data setup time
x	I <sup>2</sup> C Master	Unused in this mode

### Bits 3:0 – SSPM[3:0]

Master Synchronous Serial Port Mode Select bits<sup>(4)</sup>

Value	Description
1111	I <sup>2</sup> C Slave mode: 10-bit address with Start and Stop bit interrupts enabled
1110	I <sup>2</sup> C Slave mode: 7-bit address with Start and Stop bit interrupts enabled
1101	Reserved - do not use
1100	Reserved - do not use
1011	I <sup>2</sup> C Firmware Controlled Master mode (slave Idle)
1010	SPI Master mode: Clock = $F_{OSC}/(4*(SSPxADD+1))$ . SSPxADD must be greater than 0. <sup>(3)</sup>
1001	Reserved - do not use
1000	I <sup>2</sup> C Master mode: Clock = $F_{OSC}/(4 * (SSPxADD + 1))$
0111	I <sup>2</sup> C Slave mode: 10-bit address
0110	I <sup>2</sup> C Slave mode: 7-bit address
0101	SPI Slave mode: Clock = SCKx pin. $\overline{SSx}$ pin control is disabled
0100	SPI Slave mode: Clock = SCKx pin. $\overline{SSx}$ pin control is enabled
0011	SPI Master mode: Clock = TMR2 output/2
0010	SPI Master mode: Clock = $F_{osc}/64$
0001	SPI Master mode: Clock = $F_{osc}/16$
0000	SPI Master mode: Clock = $F_{osc}/4$

### Note:

1. In Master mode, the overflow bit is not set since each new reception (and transmission) is initiated by writing to the SSPxBUF register.
2. When enabled, these pins must be properly configured as inputs or outputs.
3. SSPxADD = 0 is not supported.
4. Bit combinations not specifically listed here are either reserved or implemented in I<sup>2</sup>C mode only.

### 35.9.3 SSPxCON2

**Name:** SSPxCON2  
**Address:** 0x191,0x19B

Control Register for I<sup>2</sup>C Operation Only

MSSP Control Register 2

Bit	7	6	5	4	3	2	1	0
	GCEN	ACKSTAT	ACKDT	ACKEN	RCEN	PEN	RSEN	SEN
Access	R/W	R/W/HC	R/W	R/W	R/W	R/W	R/W	R/W
Reset	0	0	0	0	0	0	0	0

#### Bit 7 – GCEN

General Call Enable bit (Slave mode only)

Value	Mode	Description
x	Master mode	Don't care
1	Slave mode	General call is enabled
0	Slave mode	General call is not enabled

#### Bit 6 – ACKSTAT Acknowledge Status bit (Master Transmit mode only)

Value	Description
1	Acknowledge was not received from slave
0	Acknowledge was received from slave

#### Bit 5 – ACKDT

Acknowledge Data bit (Master Receive mode only)<sup>(1)</sup>

Value	Description
1	Not Acknowledge
0	Acknowledge

#### Bit 4 – ACKEN

Acknowledge Sequence Enable bit<sup>(2)</sup>

Value	Description
1	Initiates Acknowledge sequence on SDAx and SCLx pins and transmits ACKDT data bit; automatically cleared by hardware
0	Acknowledge sequence is Idle

#### Bit 3 – RCEN

Receive Enable bit (Master Receive mode only)<sup>(2)</sup>

Value	Description
1	Enables Receive mode for I <sup>2</sup> C
0	Receive is Idle

#### Bit 2 – PEN

Stop Condition Enable bit (Master mode only)<sup>(2)</sup>

# PIC16(L)F18455/56

## (MSSP) Master Synchronous Serial Port Module

Value	Description
1	Initiates Stop condition on SDAx and SCLx pins; automatically cleared by hardware
0	Stop condition is Idle

### Bit 1 – RSEN

Repeated Start Condition Enable bit (Master mode only)<sup>(2)</sup>

Value	Description
1	Initiates Repeated Start condition on SDAx and SCLx pins; automatically cleared by hardware
0	Repeated Start condition is Idle

### Bit 0 – SEN

Start Condition Enable bit (Master mode only)<sup>(2)</sup>

Value	Description
1	Initiates Start condition on SDAx and SCLx pins; automatically cleared by hardware
0	Start condition is Idle

### Note:

1. The value that will be transmitted when the user initiates an Acknowledge sequence at the end of a receive.
2. If the I<sup>2</sup>C module is active, these bits may not be set (no spooling) and the SSPxBUF may not be written (or writes to the SSPxBUF are disabled).

# PIC16(L)F18455/56

## (MSSP) Master Synchronous Serial Port Module

### 35.9.4 SSPxCON3

**Name:** SSPxCON3  
**Address:** 0x192,0x19C

MSSP Control Register 3

Bit	7	6	5	4	3	2	1	0
	ACKTIM	PCIE	SCIE	BOEN	SDAHT	SBCDE	AHEN	DHEN
Access	R/HS/HC	R/W	R/W	R/W	R/W	R/W	R/W	R/W
Reset	0	0	0	0	0	0	0	0

**Bit 7 – ACKTIM** Acknowledge Time Status bit  
 Unused in Master mode.

Value	Mode	Description
x	SPI or I <sup>2</sup> C Master	This bit is not used
1	I <sup>2</sup> C Slave and AHEN = 1 or DHEN = 1	Eighth falling edge of SCL has occurred and the $\overline{\text{ACK}}$ /NACK state is active
0	I <sup>2</sup> C Slave	$\overline{\text{ACK}}$ /NACK state is not active. Transitions low on ninth rising edge of SCL.

**Bit 6 – PCIE**  
 Stop Condition Interrupt Enable bit<sup>(1)</sup>

Value	Mode	Description
x	SPI or SSPM = 1111 or 0111	Don't care
1	SSPM ≠ 1111 and SSPM ≠ 0111	Enable interrupt on detection of Stop condition
0	SSPM ≠ 1111 and SSPM ≠ 0111	Stop detection interrupts are disabled

**Bit 5 – SCIE** Start Condition Interrupt Enable bit

Value	Mode	Description
x	SPI or SSPM = 1111 or 0111	Don't care
1	SSPM ≠ 1111 and SSPM ≠ 0111	Enable interrupt on detection of Start condition
0	SSPM ≠ 1111 and SSPM ≠ 0111	Start detection interrupts are disabled

**Bit 4 – BOEN**  
 Buffer Overwrite Enable bit<sup>(2)</sup>

Value	Mode	Description
1	SPI	SSPxBUF is updated every time a new data byte is available, ignoring the BF bit
0	SPI	If a new byte is receive with BF set then SSPOV is set and SSPxBUF is not updated
1	I <sup>2</sup> C	SSPxBUF is updated every time a new data byte is available, ignoring the SSPOV effect on updating the buffer
0	I <sup>2</sup> C	SSPxBUF is only updated when SSPOV is clear

**Bit 3 – SDAHT** SDA Hold Time Selection bit



# PIC16(L)F18455/56

## (MSSP) Master Synchronous Serial Port Module

Value	Mode	Description
x	SPI	Not used in SPI mode
1	I <sup>2</sup> C	Minimum of 300ns hold time on SDA after the falling edge of SCL
0	I <sup>2</sup> C	Minimum of 100ns hold time on SDA after the falling edge of SCL

**Bit 2 – SBCDE** Slave Mode Bus Collision Detect Enable bit  
Unused in Master mode.

Value	Mode	Description
x	SPI or I <sup>2</sup> C Master	Don't care
1	I <sup>2</sup> C Slave	Collision detection is enabled
0	I <sup>2</sup> C Slave	Collision detection is not enabled

**Bit 1 – AHEN** Address Hold Enable bit

Value	Mode	Description
x	SPI or I <sup>2</sup> C Master	Don't care
1	I <sup>2</sup> C Slave	Address hold is enabled. As a result CKP is cleared after the eighth falling SCL edge of an address byte reception. Software must set the CKP bit to resume operation.
0	I <sup>2</sup> C Slave	Address hold is not enabled

**Bit 0 – DHEN** Data Hold Enable bit

Value	Mode	Description
x	SPI or I <sup>2</sup> C Master	Don't care
1	I <sup>2</sup> C Slave	Data hold is enabled. As a result CKP is cleared after the eighth falling SCL edge of a data byte reception. Software must set the CKP bit to resume operation.
0	I <sup>2</sup> C Slave	Data hold is not enabled

**Note:**

1. This bit has no effect in Slave modes that Start and Stop condition detection is explicitly listed as enabled.
2. For daisy-chained SPI operation; allows the user to ignore all but the last received byte. SSPOV is still set when a new byte is received and BF = 1, but hardware continues to write the most recent byte to SSPxBUF.

# PIC16(L)F18455/56

## (MSSP) Master Synchronous Serial Port Module

### 35.9.5 SSPxBUF

**Name:** SSPxBUF  
**Address:** 0x18C,0x196

MSSP Data Buffer Register

Bit	7	6	5	4	3	2	1	0
	BUF[7:0]							
Access	R/W	R/W	R/W	R/W	R/W	R/W	R/W	R/W
Reset	x	x	x	x	x	x	x	x

**Bits 7:0 – BUF[7:0]** MSSP Input and Output Data Buffer bits

### 35.9.6 SSPxADD

**Name:** SSPxADD  
**Address:** 0x18D,0x197

MSSP Baud Rate Divider and Address Register

	Bit	7	6	5	4	3	2	1	0
		ADD[7:0]							
Access		R/W	R/W	R/W	R/W	R/W	R/W	R/W	R/W
Reset		0	0	0	0	0	0	0	0

#### Bits 7:0 – ADD[7:0]

- SPI and I<sup>2</sup>C Master: Baud rate divider
- I<sup>2</sup>C Slave: Address bits

Value	Mode	Description
3 to 255	SPI and I <sup>2</sup> C Master	Baud rate divider. SCK/SCL pin clock period = ((n + 1) * 4) / F <sub>OSC</sub> . Values less than 3 are not valid.
2, 4, 6, 8	I <sup>2</sup> C 10-bit Slave MS Address	Bits 7-3 and Bit 0 are not used and are don't care. Bits 2:1 are bits 9:8 of the 10-bit Slave Most Significant Address
n	I <sup>2</sup> C 10-bit Slave LS Address	Bits 7:0 of 10-Bit Slave Least Significant Address
2*(1 to 127)	I <sup>2</sup> C 7-bit Slave	Bit 0 is not used and is don't care. Bits 7:1 are the 7-bit Slave Address

### 35.9.7 SSPxMSK

**Name:** SSPxMSK  
**Address:** 0x18E,0x198

MSSP Address Mask Register

Bit	7	6	5	4	3	2	1	0
	MSK[6:0]							MSK0
Access	R/W	R/W	R/W	R/W	R/W	R/W	R/W	R/W
Reset	1	1	1	1	1	1	1	1

#### Bits 7:1 – MSK[6:0] Mask bits

Value	Mode	Description
1	I <sup>2</sup> C Slave	The received address bit n is compared to SSPxADD bit n to detect I <sup>2</sup> C address match
0	I <sup>2</sup> C Slave	The received address bit n is not used to detect I <sup>2</sup> C address match

#### Bit 0 – MSK0

Mask bit for I<sup>2</sup>C 10-bit Slave mode

Value	Mode	Description
1	I <sup>2</sup> C 10-bit Slave	The received address bit 0 is compared to SSPxADD bit 0 to detect I <sup>2</sup> C address match
0	I <sup>2</sup> C 10-bit Slave	The received address bit 0 is not used to detect I <sup>2</sup> C address match
x	SPI or I <sup>2</sup> C 7-bit	Don't care

## 36. (EUSART) Enhanced Universal Synchronous Asynchronous Receiver Transmitter

The Enhanced Universal Synchronous Asynchronous Receiver Transmitter (EUSART) module is a serial I/O communications peripheral. It contains all the clock generators, shift registers and data buffers necessary to perform an input or output serial data transfer independent of device program execution. The EUSART, also known as a Serial Communications Interface (SCI), can be configured as a full-duplex asynchronous system or half-duplex synchronous system. Full-Duplex mode is useful for communications with peripheral systems, such as CRT terminals and personal computers. Half-Duplex Synchronous mode is intended for communications with peripheral devices, such as A/D or D/A integrated circuits, serial EEPROMs or other microcontrollers. These devices typically do not have internal clocks for baud rate generation and require the external clock signal provided by a master synchronous device.

The EUSART module includes the following capabilities:

- Full-duplex asynchronous transmit and receive
- Two-character input buffer
- One-character output buffer
- Programmable 8-bit or 9-bit character length
- Address detection in 9-bit mode
- Input buffer overrun error detection
- Received character framing error detection
- Half-duplex synchronous master
- Half-duplex synchronous slave
- Programmable clock polarity in Synchronous modes
- Sleep operation

The EUSART module implements the following additional features, making it ideally suited for use in Local Interconnect Network (LIN) bus systems:

- Automatic detection and calibration of the baud rate
- Wake-up on Break reception
- 13-bit Break character transmit

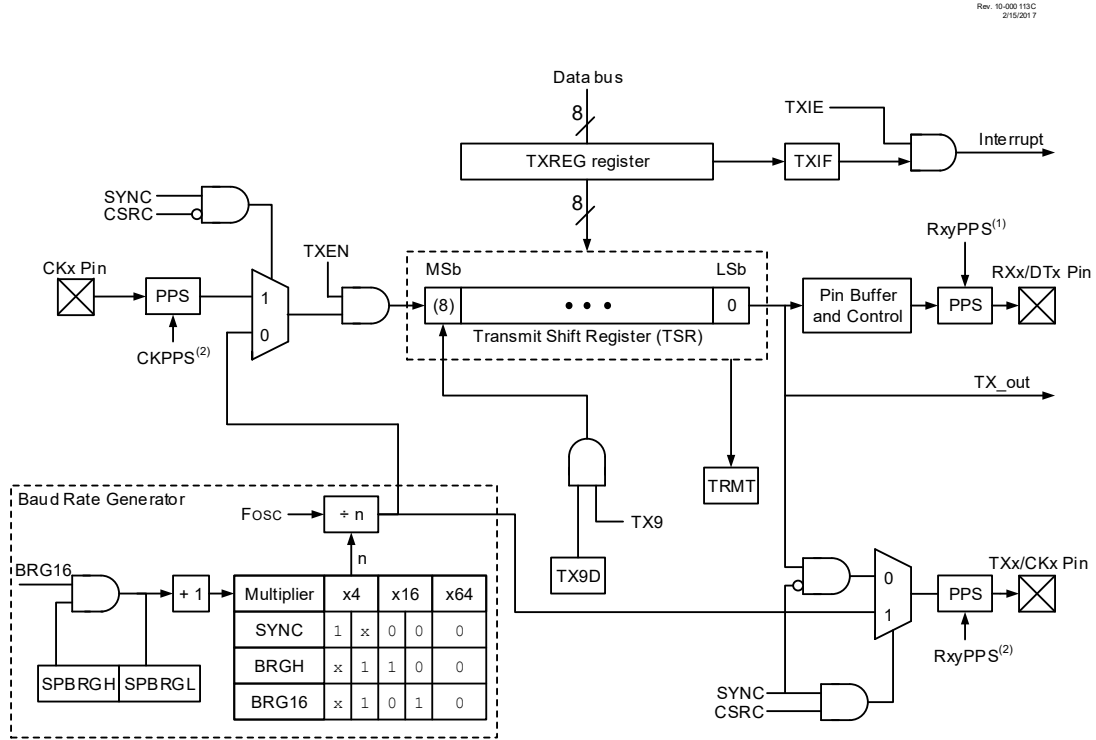
Block diagrams of the EUSART transmitter and receiver are shown in [Figure 36-1](#) and [Figure 36-2](#).

The operation of the EUSART module consists of six registers:

- Transmit Status and Control ([36.6.2 TXxSTA](#))
- Receive Status and Control ([36.6.1 RCxSTA](#))
- Baud Rate Control ([36.6.3 BAUDxCON](#))
- Baud Rate Value ([36.6.4 SPxBRG](#))
- Receive Data Register ([36.6.5 RCxREG](#))
- Transmit Data Register ([36.6.6 TXxREG](#))

The RXx/DTx and TXx/CKx input pins are selected with the RXxPPS and TXxPPS registers, respectively. TXx, CKx, and DTx output pins are selected with each pin's RxyPPS register. Since the RX input is coupled with the DT output in Synchronous mode, it is the user's responsibility to select the same pin for both of these functions when operating in Synchronous mode. The EUSART control logic will control the data direction drivers automatically.

**Figure 36-1. EUSART Transmit Block Diagram**



- Note 1:** In Synchronous mode, the DT output and RX input PPS selections should enable the same pin.
- 2:** In Master Synchronous mode the TX output and CK input PPS selections should enable the same pin.



- TXEN = 1 (enables the transmitter circuitry of the EUSART)
- SYNC = 0 (configures the EUSART for asynchronous operation)
- SPEN = 1 (enables the EUSART and automatically enables the output drivers for the RxyPPS selected as the TXx/CKx output)

All other EUSART control bits are assumed to be in their default state.

If the TXx/CKx pin is shared with an analog peripheral, the analog I/O function must be disabled by clearing the corresponding ANSEL bit.



**Important:** The TXxIF Transmitter Interrupt flag is set when the TXEN enable bit is set and the TSR is idle.

---

#### 36.1.1.2 Transmitting Data

A transmission is initiated by writing a character to the TXxREG register. If this is the first character, or the previous character has been completely flushed from the TSR, the data in the TXxREG is immediately transferred to the TSR register. If the TSR still contains all or part of a previous character, the new character data is held in the TXxREG until the Stop bit of the previous character has been transmitted. The pending character in the TXxREG is then transferred to the TSR in one  $T_{CY}$  immediately following the Stop bit transmission. The transmission of the Start bit, data bits and Stop bit sequence commences immediately following the transfer of the data to the TSR from the TXxREG.

#### 36.1.1.3 Transmit Data Polarity

The polarity of the transmit data can be controlled with the SCKP bit of the BAUDxCON register. The default state of this bit is '0' which selects high true transmit idle and data bits. Setting the SCKP bit to '1' will invert the transmit data resulting in low true idle and data bits. The SCKP bit controls transmit data polarity in Asynchronous mode only. In Synchronous mode, the SCKP bit has a different function. See the [36.3.1.2 Clock Polarity](#) section for more detail.

#### 36.1.1.4 Transmit Interrupt Flag

The TXxIF interrupt flag bit of the PIRx register is set whenever the EUSART transmitter is enabled and no character is being held for transmission in the TXxREG. In other words, the TXxIF bit is only clear when the TSR is busy with a character and a new character has been queued for transmission in the TXxREG. The TXxIF flag bit is not cleared immediately upon writing TXxREG. TXxIF becomes valid in the second instruction cycle following the write execution. Polling TXxIF immediately following the TXxREG write will return invalid results. The TXxIF bit is read-only, it cannot be set or cleared by software.

The TXxIF interrupt can be enabled by setting the TXxIE interrupt enable bit of the PIEx register. However, the TXxIF flag bit will be set whenever the TXxREG is empty, regardless of the state of TXxIE enable bit.

To use interrupts when transmitting data, set the TXxIE bit only when there is more data to send. Clear the TXxIE interrupt enable bit upon writing the last character of the transmission to the TXxREG.

#### 36.1.1.5 TSR Status

The TRMT bit of the TXxSTA register indicates the status of the TSR register. This is a read-only bit. The TRMT bit is set when the TSR register is empty and is cleared when a character is transferred to the TSR register from the TXxREG. The TRMT bit remains clear until all bits have been shifted out of the TSR register. No interrupt logic is tied to this bit, so the user needs to poll this bit to determine the TSR status.





**Important:** The TSR register is not mapped in data memory, so it is not available to the user.

### 36.1.1.6 Transmitting 9-Bit Characters

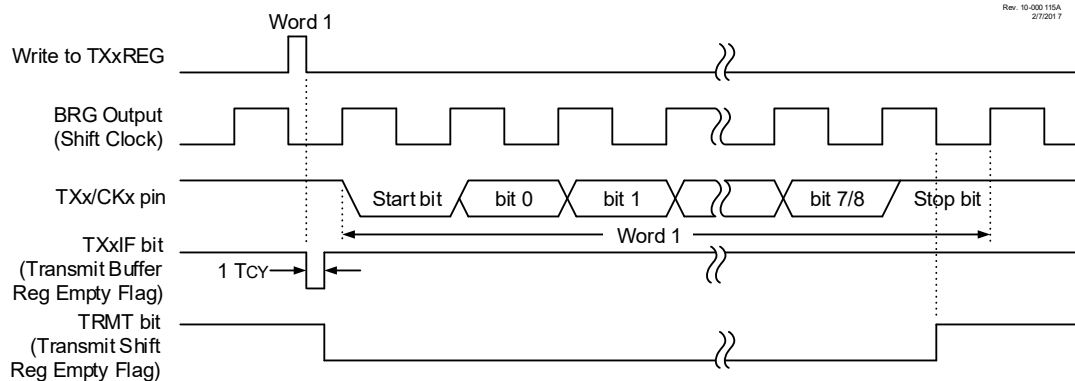
The EUSART supports 9-bit character transmissions. When the TX9 bit of the TXxSTA register is set, the EUSART will shift nine bits out for each character transmitted. The TX9D bit of the TXxSTA register is the ninth, and Most Significant data bit. When transmitting 9-bit data, the TX9D data bit must be written before writing the eight Least Significant bits into the TXxREG. All nine bits of data will be transferred to the TSR shift register immediately after the TXxREG is written.

A special 9-bit Address mode is available for use with multiple receivers. See the [36.1.2.7 Address Detection](#) section for more information on the Address mode.

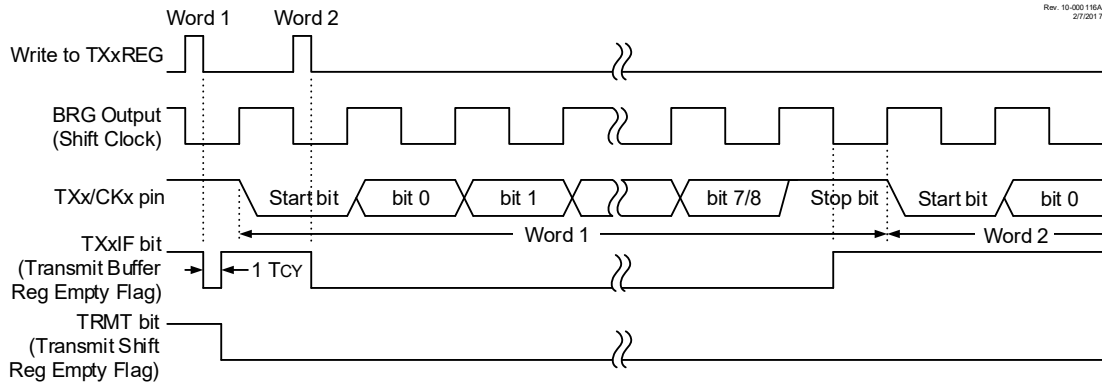
### 36.1.1.7 Asynchronous Transmission Setup

1. Initialize the SPxBRGH, SPxBRGL register pair and the BRGH and BRG16 bits to achieve the desired baud rate (see [36.2 EUSART Baud Rate Generator \(BRG\)](#)).
2. Select the transmit output pin by writing the appropriate value to the RxyPPS register.
3. Enable the asynchronous serial port by clearing the SYNC bit and setting the SPEN bit.
4. If 9-bit transmission is desired, set the TX9 control bit. A set ninth data bit will indicate that the eight Least Significant data bits are an address when the receiver is set for address detection.
5. Set SCKP bit if inverted transmit is desired.
6. Enable the transmission by setting the TXEN control bit. This will cause the TXxIF interrupt bit to be set.
7. If interrupts are desired, set the TXxIE interrupt enable bit of the PEx register
8. An interrupt will occur immediately provided that the GIE and PEIE bits of the INTCON register are also set.
9. If 9-bit transmission is selected, the ninth bit should be loaded into the TX9D data bit.
10. Load 8-bit data into the TXxREG register. This will start the transmission.

**Figure 36-3. Asynchronous Transmission**



**Figure 36-4. Asynchronous Transmission (Back-to-Back)**



### 36.1.2 EUSART Asynchronous Receiver

The Asynchronous mode is typically used in RS-232 systems. A simplified representation of the receiver is shown in the [Figure 36-2](#). The data is received on the RXx/DTx pin and drives the data recovery block. The data recovery block is actually a high-speed shifter operating at 16 times the baud rate, whereas the serial Receive Shift Register (RSR) operates at the bit rate. When all eight or nine bits of the character have been shifted in, they are immediately transferred to a two character First-In-First-Out (FIFO) memory. The FIFO buffering allows reception of two complete characters and the start of a third character before software must start servicing the EUSART receiver. The FIFO and RSR registers are not directly accessible by software. Access to the received data is via the RCxREG register.

#### 36.1.2.1 Enabling the Receiver

The EUSART receiver is enabled for asynchronous operation by configuring the following three control bits:

- CREN = 1 (enables the receiver circuitry of the EUSART)
- SYNC = 0 (configures the EUSART for asynchronous operation)
- SPEN = 1 (enables the EUSART)

All other EUSART control bits are assumed to be in their default state.

The user must set the RXxPPS register to select the RXx/DTx I/O pin and set the corresponding TRIS bit to configure the pin as an input.



**Important:** If the RX/DT function is on an analog pin, the corresponding ANSEL bit must be cleared for the receiver to function.

#### 36.1.2.2 Receiving Data

The receiver data recovery circuit initiates character reception on the falling edge of the first bit. The first bit, also known as the Start bit, is always a zero. The data recovery circuit counts one-half bit time to the center of the Start bit and verifies that the bit is still a zero. If it is not a zero then the data recovery circuit aborts character reception, without generating an error, and resumes looking for the falling edge of the Start bit. If the Start bit zero verification succeeds then the data recovery circuit counts a full bit time to the center of the next bit. The bit is then sampled by a majority detect circuit and the resulting '0' or '1' is shifted into the RSR. This repeats until all data bits have been sampled and shifted into the RSR. One final bit time is measured and the level sampled. This is the Stop bit, which is always a '1'. If the data

recovery circuit samples a '0' in the Stop bit position then a framing error is set for this character, otherwise the framing error is cleared for this character. See the [36.1.2.4 Receive Framing Error](#) section for more information on framing errors.

Immediately after all data bits and the Stop bit have been received, the character in the RSR is transferred to the EUSART receive FIFO and the RCxIF interrupt flag bit of the PIRx register is set. The top character in the FIFO is transferred out of the FIFO by reading the RCxREG register.



**Important:** If the receive FIFO is overrun, no additional characters will be received until the overrun condition is cleared. See the [36.1.2.5 Receive Overrun Error](#) section for more information.

### 36.1.2.3 Receive Interrupts

The RCxIF interrupt flag bit of the PIRx register is set whenever the EUSART receiver is enabled and there is an unread character in the receive FIFO. The RCxIF interrupt flag bit is read-only, it cannot be set or cleared by software.

RCxIF interrupts are enabled by setting all of the following bits:

- RCxIE, Interrupt Enable bit of the PIEx register
- PEIE, Peripheral Interrupt Enable bit of the INTCON register
- GIE, Global Interrupt Enable bit of the INTCON register

The RCxIF interrupt flag bit will be set when there is an unread character in the FIFO, regardless of the state of interrupt enable bits.

### 36.1.2.4 Receive Framing Error

Each character in the receive FIFO buffer has a corresponding framing error Status bit. A framing error indicates that a Stop bit was not seen at the expected time. The framing error status is accessed via the FERR bit of the RCxSTA register. The FERR bit represents the status of the top unread character in the receive FIFO. Therefore, the FERR bit must be read before reading the RCxREG.

The FERR bit is read-only and only applies to the top unread character in the receive FIFO. A framing error (FERR = 1) does not preclude reception of additional characters. It is not necessary to clear the FERR bit. Reading the next character from the FIFO buffer will advance the FIFO to the next character and the next corresponding framing error.

The FERR bit can be forced clear by clearing the SPEN bit of the RCxSTA register which resets the EUSART. Clearing the CREN bit of the RCxSTA register does not affect the FERR bit. A framing error by itself does not generate an interrupt.



**Important:** If all receive characters in the receive FIFO have framing errors, repeated reads of the RCxREG will not clear the FERR bit.

### 36.1.2.5 Receive Overrun Error

The receive FIFO buffer can hold two characters. An overrun error will be generated if a third character, in its entirety, is received before the FIFO is accessed. When this happens the OERR bit of the RCxSTA register is set. The characters already in the FIFO buffer can be read but no additional characters will be received until the error is cleared. The error must be cleared by either clearing the CREN bit of the RCxSTA register or by resetting the EUSART by clearing the SPEN bit of the RCxSTA register.

#### **36.1.2.6 Receiving 9-Bit Characters**

The EUSART supports 9-bit character reception. When the RX9 bit of the RCxSTA register is set the EUSART will shift nine bits into the RSR for each character received. The RX9D bit of the RCxSTA register is the ninth and Most Significant data bit of the top unread character in the receive FIFO. When reading 9-bit data from the receive FIFO buffer, the RX9D data bit must be read before reading the eight Least Significant bits from the RCxREG.

#### **36.1.2.7 Address Detection**

A special Address Detection mode is available for use when multiple receivers share the same transmission line, such as in RS-485 systems. Address detection is enabled by setting the ADDEN bit of the RCxSTA register.

Address detection requires 9-bit character reception. When address detection is enabled, only characters with the ninth data bit set will be transferred to the receive FIFO buffer, thereby setting the RCxIF interrupt bit. All other characters will be ignored.

Upon receiving an address character, user software determines if the address matches its own. Upon address match, user software must disable address detection by clearing the ADDEN bit before the next Stop bit occurs. When user software detects the end of the message, determined by the message protocol used, software places the receiver back into the Address Detection mode by setting the ADDEN bit.

#### **36.1.2.8 Asynchronous Reception Setup**

1. Initialize the SPxBRGH:SPxBRGL register pair and the BRGH and BRG16 bits to achieve the desired baud rate (see the [36.2 EUSART Baud Rate Generator \(BRG\)](#) section).
2. Set the RXxPPS register to select the RXx/DTx input pin.
3. Clear the ANSEL bit for the RXx pin (if applicable).
4. Enable the serial port by setting the SPEN bit. The SYNC bit must be clear for asynchronous operation.
5. If interrupts are desired, set the RCxIE bit of the PEx register and the GIE and PEIE bits of the INTCON register.
6. If 9-bit reception is desired, set the RX9 bit.
7. Enable reception by setting the CREN bit.
8. The RCxIF interrupt flag bit will be set when a character is transferred from the RSR to the receive buffer. An interrupt will be generated if the RCxIE interrupt enable bit was also set.
9. Read the RCxSTA register to get the error flags and, if 9-bit data reception is enabled, the ninth data bit.
10. Get the received eight Least Significant data bits from the receive buffer by reading the RCxREG register.
11. If an overrun occurred, clear the OERR flag by clearing the CREN receiver enable bit.

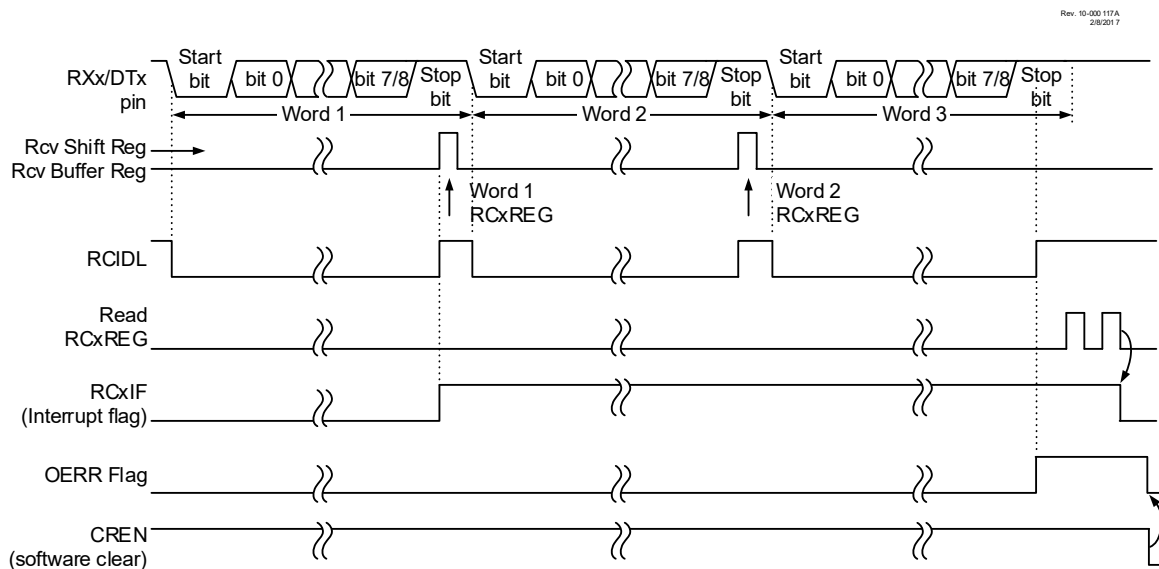
#### **36.1.2.9 9-Bit Address Detection Mode Setup**

This mode would typically be used in RS-485 systems. To set up an Asynchronous Reception with Address Detect Enable follow these steps:

1. Initialize the SPxBRGH:SPxBRGL register pair and the BRGH and BRG16 bits to achieve the desired baud rate (see the [36.2 EUSART Baud Rate Generator \(BRG\)](#) section).
2. Set the RXxPPS register to select the RXx input pin.
3. Clear the ANSEL bit for the RXx pin (if applicable).
4. Enable the serial port by setting the SPEN bit. The SYNC bit must be clear for asynchronous operation.

5. If interrupts are desired, set the RCxIE bit of the PEx register and the GIE and PEIE bits of the INTCON register.
6. Enable 9-bit reception by setting the RX9 bit.
7. Enable address detection by setting the ADDEN bit.
8. Enable reception by setting the CREN bit.
9. The RCxIF interrupt flag bit will be set when a character with the ninth bit set is transferred from the RSR to the receive buffer. An interrupt will be generated if the RCxIE interrupt enable bit is also set.
10. Read the RCxSTA register to get the error flags. The ninth data bit will always be set.
11. Get the received eight Least Significant data bits from the receive buffer by reading the RCxREG register. Software determines if this is the device's address.
12. If an overrun occurred, clear the OERR flag by clearing the CREN receiver enable bit.
13. If the device has been addressed, clear the ADDEN bit to allow all received data into the receive buffer and generate interrupts.

**Figure 36-5. Asynchronous Reception**



**Note:** This timing diagram shows three bytes appearing on the RXx input. The OERR flag is set because the RCxREG is not read before the third word is received.

### 36.1.3 Clock Accuracy with Asynchronous Operation

The factory calibrates the internal oscillator block output (INTOSC). However, the INTOSC frequency may drift as  $V_{DD}$  or temperature changes, and this directly affects the asynchronous baud rate. Two methods may be used to adjust the baud rate clock, but both require a reference clock source of some kind.

The first (preferred) method uses the OSCTUNE register to adjust the INTOSC output. Adjusting the value in the OSCTUNE register allows for fine resolution changes to the system clock source.

The other method adjusts the value in the Baud Rate Generator. This can be done automatically with the Auto-Baud Detect feature (see [36.2.1 Auto-Baud Detect](#)). There may not be fine enough resolution when adjusting the Baud Rate Generator to compensate for a gradual change in the peripheral clock frequency.

## 36.2 EUSART Baud Rate Generator (BRG)

The Baud Rate Generator (BRG) is an 8-bit or 16-bit timer that is dedicated to the support of both the asynchronous and synchronous EUSART operation. By default, the BRG operates in 8-bit mode. Setting the BRG16 bit of the BAUDxCON register selects 16-bit mode.

The SPxBRGH, SPxBRGL register pair determines the period of the free running baud rate timer. In Asynchronous mode the multiplier of the baud rate period is determined by both the BRGH bit of the TXxSTA register and the BRG16 bit of the BAUDxCON register. In Synchronous mode, the BRGH bit is ignored.

Table 36-1 contains the formulas for determining the baud rate. Equation 36-1 provides a sample calculation for determining the baud rate and baud rate error.

Typical baud rates and error values for various asynchronous modes have been computed and are shown in Table 36-2. It may be advantageous to use the high baud rate (BRGH = 1), or the 16-bit BRG (BRG16 = 1) to reduce the baud rate error. The 16-bit BRG mode is used to achieve slow baud rates for fast oscillator frequencies. The BRGH bit is used to achieve very high baud rates.

Writing a new value to the SPxBRGH, SPxBRGL register pair causes the BRG timer to be reset (or cleared). This ensures that the BRG does not wait for a timer overflow before outputting the new baud rate.

If the system clock is changed during an active receive operation, a receive error or data loss may result. To avoid this problem, check the status of the RCIDL bit to make sure that the receive operation is idle before changing the system clock.

### Equation 36-1. Calculating Baud Rate Error

For a device with Fosc of 16 MHz, desired baud rate of 9600, Asynchronous mode, 8-bit BRG:

$$DesiredBaudrate = \frac{F_{osc}}{(64 \times SPxBRG) + 1}$$

Solving for SPxBRG:

$$SPxBRG = \frac{F_{osc}}{64 \times DesiredBaudrate} - 1$$

$$SPxBRG = \frac{16000000}{64 \times 9600} - 1$$

$$SPxBRG = 25.042 \approx 25$$

$$CalculatedBaudrate = \frac{16000000}{64 \times (25 + 1)}$$

$$CalculatedBaudrate = 9615$$

$$Error = \frac{CalculatedBaudrate - DesiredBaudrate}{DesiredBaudrate}$$

$$Error = \frac{9615 - 9600}{9600}$$

$$Error = 0.16\%$$

# PIC16(L)F18455/56

## (EUSART) Enhanced Universal Synchronous Asyn...

**Table 36-1. Baud Rate Formulas**

Configuration Bits			BRG/EUSART Mode	Baud Rate Formula
SYNC	BRG16	BRGH		
0	0	0	8-bit/Asynchronous	$F_{OSC}/[64 (n+1)]$
0	0	1	8-bit/Asynchronous	$F_{OSC}/[16 (n+1)]$
0	1	0	16-bit/Asynchronous	
0	1	1	16-bit/Asynchronous	$F_{OSC}/[4 (n+1)]$
1	0	x	8-bit/Synchronous	
1	1	x	16-bit/Synchronous	

**Note:** x = Don't care, n = value of SPxBRGH:SPxBRGL register pair.

**Table 36-2. Sample Baud Rates for Asynchronous Modes**

BAUD RATE	SYNC = 0, BRGH = 0, BRG16 = 0											
	F <sub>OSC</sub> = 32.000 MHz			F <sub>OSC</sub> = 20.000 MHz			F <sub>OSC</sub> = 18.432 MHz			F <sub>OSC</sub> = 11.0592 MHz		
	Actual Rate	% Error	SPBRG value (decimal)	Actual Rate	% Error	SPBRG value (decimal)	Actual Rate	% Error	SPBRG value (decimal)	Actual Rate	% Error	SPBRG value (decimal)
300	—	—	—	—	—	—	—	—	—	—	—	—
1200	—	—	—	1221	1.73	255	1200	0.00	239	1200	0.00	143
2400	2404	0.16	207	2404	0.16	129	2400	0.00	119	2400	0.00	71
9600	9615	0.16	51	9470	-1.36	32	9600	0.00	29	9600	0.00	17
10417	10417	0.00	47	10417	0.00	29	10286	-1.26	27	10165	-2.42	16
19.2k	19.23k	0.16	25	19.53k	1.73	15	19.20k	0.00	14	19.20k	0.00	8
57.6k	55.55k	-3.55	3	—	—	—	57.60k	0.00	7	57.60k	0.00	2
115.2k	—	—	—	—	—	—	—	—	—	—	—	—

BAUD RATE	SYNC = 0, BRGH = 0, BRG16 = 0											
	Fosc = 8.000 MHz			Fosc = 4.000 MHz			Fosc = 3.6864 MHz			Fosc = 1.000 MHz		
	Actual Rate	% Error	SPBRG value (decimal)	Actual Rate	% Error	SPBRG value (decimal)	Actual Rate	% Error	SPBRG value (decimal)	Actual Rate	% Error	SPBRG value (decimal)
300	—	—	—	300	0.16	207	300	0.00	191	300	0.16	51
1200	1202	0.16	103	1202	0.16	51	1200	0.00	47	1202	0.16	12
2400	2404	0.16	51	2404	0.16	25	2400	0.00	23	—	—	—
9600	9615	0.16	12	—	—	—	9600	0.00	5	—	—	—

# PIC16(L)F18455/56

## (EUSART) Enhanced Universal Synchronous Asyn...

10417	10417	0.00	11	10417	0.00	5	—	—	—	—	—	—
19.2k	—	—	—	—	—	—	19.20k	0.00	2	—	—	—
57.6k	—	—	—	—	—	—	57.60k	0.00	0	—	—	—
115.2k	—	—	—	—	—	—	—	—	—	—	—	—

BAUD RATE	SYNC = 0, BRGH = 1, BRG16 = 0											
	Fosc = 32.000 MHz			Fosc = 20.000 MHz			Fosc = 18.432 MHz			Fosc = 11.0592 MHz		
	Actual Rate	% Error	SPBRG value (decimal)	Actual Rate	% Error	SPBRG value (decimal)	Actual Rate	% Error	SPBRG value (decimal)	Actual Rate	% Error	SPBRG value (decimal)
300	—	—	—	—	—	—	—	—	—	—	—	—
1200	—	—	—	—	—	—	—	—	—	—	—	—
2400	—	—	—	—	—	—	—	—	—	—	—	—
9600	9615	0.16	207	9615	0.16	129	9600	0.00	119	9600	0.00	71
10417	10417	0.00	191	10417	0.00	119	10378	-0.37	110	10473	0.53	65
19.2k	19.23k	0.16	103	19.23k	0.16	64	19.20k	0.00	59	19.20k	0.00	35
57.6k	57.14k	-0.79	34	56.82k	-1.36	21	57.60k	0.00	19	57.60k	0.00	11
115.2k	117.64k	2.12	16	113.64k	-1.36	10	115.2k	0.00	9	115.2k	0.00	5

BAUD RATE	SYNC = 0, BRGH = 1, BRG16 = 0											
	Fosc = 8.000 MHz			Fosc = 4.000 MHz			Fosc = 3.6864 MHz			Fosc = 1.000 MHz		
	Actual Rate	% Error	SPBRG value (decimal)	Actual Rate	% Error	SPBRG value (decimal)	Actual Rate	% Error	SPBRG value (decimal)	Actual Rate	% Error	SPBRG value (decimal)
300	—	—	—	—	—	—	—	—	—	300	0.16	207
1200	—	—	—	1202	0.16	207	1200	0.00	191	1202	0.16	51
2400	2404	0.16	207	2404	0.16	103	2400	0.00	95	2404	0.16	25
9600	9615	0.16	51	9615	0.16	25	9600	0.00	23	—	—	—
10417	10417	0.00	47	10417	0.00	23	10473	0.53	21	10417	0.00	5
19.2k	19231	0.16	25	19.23k	0.16	12	19.2k	0.00	11	—	—	—
57.6k	55556	-3.55	8	—	—	—	57.60k	0.00	3	—	—	—
115.2k	—	—	—	—	—	—	115.2k	0.00	1	—	—	—

BAUD RATE	SYNC = 0, BRGH = 0, BRG16 = 1											
	Fosc = 32.000 MHz			Fosc = 20.000 MHz			Fosc = 18.432 MHz			Fosc = 11.0592 MHz		



# PIC16(L)F18455/56

## (EUSART) Enhanced Universal Synchronous Asyn...

	Actual Rate	% Error	SPBRG value (decimal)	Actual Rate	% Error	SPBRG value (decimal)	Actual Rate	% Error	SPBRG value (decimal)	Actual Rate	% Error	SPBRG value (decimal)
300	300.0	0.00	6666	300.0	-0.01	4166	300.0	0.00	3839	300.0	0.00	2303
1200	1200	-0.02	3332	1200	-0.03	1041	1200	0.00	959	1200	0.00	575
2400	2401	-0.04	832	2399	-0.03	520	2400	0.00	479	2400	0.00	287
9600	9615	0.16	207	9615	0.16	129	9600	0.00	119	9600	0.00	71
10417	10417	0.00	191	10417	0.00	119	10378	-0.37	110	10473	0.53	65
19.2k	19.23k	0.16	103	19.23k	0.16	64	19.20k	0.00	59	19.20k	0.00	35
57.6k	57.14k	-0.79	34	56.818	-1.36	21	57.60k	0.00	19	57.60k	0.00	11
115.2k	117.6k	2.12	16	113.636	-1.36	10	115.2k	0.00	9	115.2k	0.00	5

BAUD RATE	SYNC = 0, BRGH = 0, BRG16 = 1											
	Fosc = 8.000 MHz			Fosc = 4.000 MHz			Fosc = 3.6864 MHz			Fosc = 1.000 MHz		
	Actual Rate	% Error	SPBRG value (decimal)	Actual Rate	% Error	SPBRG value (decimal)	Actual Rate	% Error	SPBRG value (decimal)	Actual Rate	% Error	SPBRG value (decimal)
300	299.9	-0.02	1666	300.1	0.04	832	300.0	0.00	767	300.5	0.16	207
1200	1199	-0.08	416	1202	0.16	207	1200	0.00	191	1202	0.16	51
2400	2404	0.16	207	2404	0.16	103	2400	0.00	95	2404	0.16	25
9600	9615	0.16	51	9615	0.16	25	9600	0.00	23	—	—	—
10417	10417	0.00	47	10417	0.00	23	10473	0.53	21	10417	0.00	5
19.2k	19.23k	0.16	25	19.23k	0.16	12	19.20k	0.00	11	—	—	—
57.6k	55556	-3.55	8	—	—	—	57.60k	0.00	3	—	—	—
115.2k	—	—	—	—	—	—	115.2k	0.00	1	—	—	—

BAUD RATE	SYNC = 0, BRGH = 1, BRG16 = 1 or SYNC = 1, BRG16 = 1											
	Fosc = 32.000 MHz			Fosc = 20.000 MHz			Fosc = 18.432 MHz			Fosc = 11.0592 MHz		
	Actual Rate	% Error	SPBRG value (decimal)	Actual Rate	% Error	SPBRG value (decimal)	Actual Rate	% Error	SPBRG value (decimal)	Actual Rate	% Error	SPBRG value (decimal)
300	300.0	0.00	26666	300.0	0.00	16665	300.0	0.00	15359	300.0	0.00	9215
1200	1200	0.00	6666	1200	-0.01	4166	1200	0.00	3839	1200	0.00	2303
2400	2400	0.01	3332	2400	0.02	2082	2400	0.00	1919	2400	0.00	1151
9600	9604	0.04	832	9597	-0.03	520	9600	0.00	479	9600	0.00	287

10417	10417	0.00	767	10417	0.00	479	10425	0.08	441	10433	0.16	264
19.2k	19.18k	-0.08	416	19.23k	0.16	259	19.20k	0.00	239	19.20k	0.00	143
57.6k	57.55k	-0.08	138	57.47k	-0.22	86	57.60k	0.00	79	57.60k	0.00	47
115.2k	115.9k	0.64	68	116.3k	0.94	42	115.2k	0.00	39	115.2k	0.00	23

BAUD RATE	SYNC = 0, BRGH = 1, BRG16 = 1 or SYNC = 1, BRG16 = 1											
	Fosc = 8.000 MHz			Fosc = 4.000 MHz			Fosc = 3.6864 MHz			Fosc = 1.000 MHz		
	Actual Rate	% Error	SPBRG value (decimal)	Actual Rate	% Error	SPBRG value (decimal)	Actual Rate	% Error	SPBRG value (decimal)	Actual Rate	% Error	SPBRG value (decimal)
300	300.0	0.00	6666	300.0	0.01	3332	300.0	0.00	3071	300.1	0.04	832
1200	1200	-0.02	1666	1200	0.04	832	1200	0.00	767	1202	0.16	207
2400	2401	0.04	832	2398	0.08	416	2400	0.00	383	2404	0.16	103
9600	9615	0.16	207	9615	0.16	103	9600	0.00	95	9615	0.16	25
10417	10417	0	191	10417	0.00	95	10473	0.53	87	10417	0.00	23
19.2k	19.23k	0.16	103	19.23k	0.16	51	19.20k	0.00	47	19.23k	0.16	12
57.6k	57.14k	-0.79	34	58.82k	2.12	16	57.60k	0.00	15	—	—	—
115.2k	117.6k	2.12	16	111.1k	-3.55	8	115.2k	0.00	7	—	—	—

### 36.2.1 Auto-Baud Detect

The EUSART module supports automatic detection and calibration of the baud rate.

In the Auto-Baud Detect (ABD) mode, the clock to the BRG is reversed. Rather than the BRG clocking the incoming RX signal, the RX signal is timing the BRG. The Baud Rate Generator is used to time the period of a received 55h (ASCII "U") which is the Sync character for the LIN bus. The unique feature of this character is that it has five rising edges including the Stop bit edge.

Setting the ABDEN bit of the BAUDxCON register starts the auto-baud calibration sequence. While the ABD sequence takes place, the EUSART state machine is held in Idle. On the first rising edge of the receive line, after the Start bit, the SPxBRG begins counting up using the BRG counter clock as shown in [Figure 36-6](#). The fifth rising edge will occur on the RXx pin at the end of the eighth bit period. At that time, an accumulated value totaling the proper BRG period is left in the SPxBRGH, SPxBRGL register pair, the ABDEN bit is automatically cleared and the RCxIF interrupt flag is set. The value in the RCxREG needs to be read to clear the RCxIF interrupt. RCxREG content should be discarded. When calibrating for modes that do not use the SPxBRGH register the user can verify that the SPxBRGL register did not overflow by checking for 00h in the SPxBRGH register.

The BRG auto-baud clock is determined by the BRG16 and BRGH bits as shown in [Table 36-3](#). During ABD, both the SPxBRGH and SPxBRGL registers are used as a 16-bit counter, independent of the BRG16 bit setting. While calibrating the baud rate period, the SPxBRGH and SPxBRGL registers are clocked at 1/8<sup>th</sup> the BRG base clock rate. The resulting byte measurement is the average bit time when clocked at full speed.

**Note:**

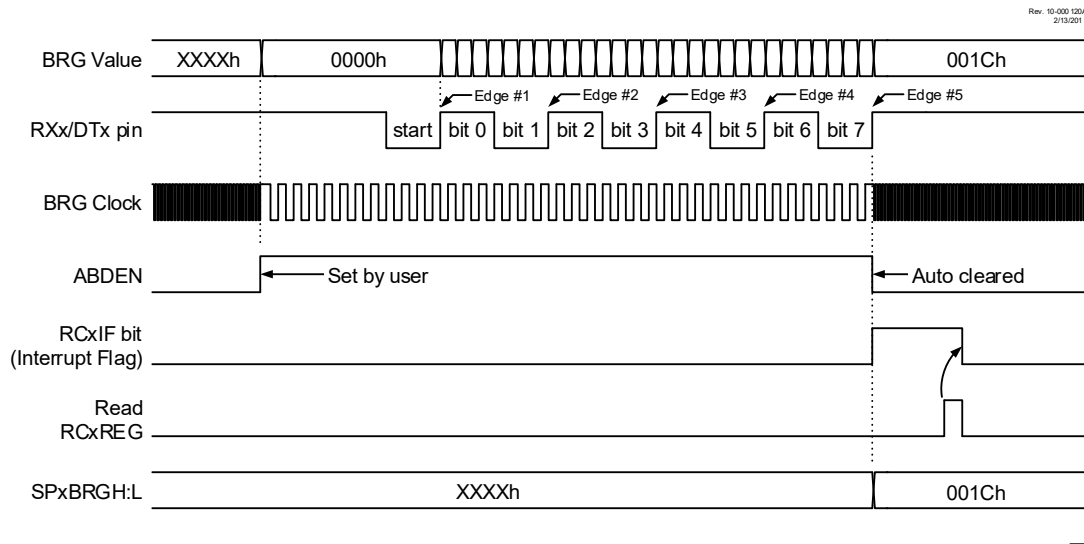
1. If the WUE bit is set with the ABDEN bit, auto-baud detection will occur on the byte following the Break character (see 36.2.3 Auto-Wake-up on Break).
2. It is up to the user to determine that the incoming character baud rate is within the range of the selected BRG clock source. Some combinations of oscillator frequency and EUSART baud rates are not possible.
3. During the auto-baud process, the auto-baud counter starts counting at one. Upon completion of the auto-baud sequence, to achieve maximum accuracy, subtract 1 from the SPxBRGH:SPxBRGL register pair.

**Table 36-3. BRG Counter Clock Rates**

BRG16	BRGH	BRG Base Clock	BRG ABD Clock
1	1	$F_{OSC}/4$	$F_{OSC}/32$
1	0	$F_{OSC}/16$	$F_{OSC}/128$
0	1	$F_{OSC}/16$	$F_{OSC}/128$
0	0	$F_{OSC}/64$	$F_{OSC}/512$

**Note:** During the ABD sequence, SPxBRGL and SPxBRGH registers are both used as a 16-bit counter, independent of the BRG16 setting.

**Figure 36-6. Automatic Baud Rate Calibration**



### 36.2.2 Auto-Baud Overflow

During the course of automatic baud detection, the ABDOVF bit of the BAUDxCON register will be set if the baud rate counter overflows before the fifth rising edge is detected on the RXx pin. The ABDOVF bit indicates that the counter has exceeded the maximum count that can fit in the 16 bits of the SPxBRGH:SPxBRGL register pair. After the ABDOVF bit has been set, the counter continues to count until the fifth rising edge is detected on the RXx pin. Upon detecting the fifth RX edge, the hardware will set the RCxIF interrupt flag and clear the ABDEN bit of the BAUDxCON register. The RCxIF flag can be subsequently cleared by reading the RCxREG register. The ABDOVF flag of the BAUDxCON register can be cleared by software directly.

To terminate the auto-baud process before the RCxIF flag is set, clear the ABDEN bit then clear the ABDOVF bit of the BAUDxCON register. The ABDOVF bit will remain set if the ABDEN bit is not cleared first.

### **36.2.3 Auto-Wake-up on Break**

During Sleep mode, all clocks to the EUSART are suspended. Because of this, the Baud Rate Generator is inactive and a proper character reception cannot be performed. The Auto-Wake-up feature allows the controller to wake-up due to activity on the RX/DT line. This feature is available only in Asynchronous mode.

The Auto-Wake-up feature is enabled by setting the WUE bit of the BAUDxCON register. Once set, the normal receive sequence on RX/DT is disabled, and the EUSART remains in an Idle state, monitoring for a wake-up event independent of the CPU mode. A wake-up event consists of a high-to-low transition on the RX/DT line. (This coincides with the start of a Sync Break or a wake-up signal character for the LIN protocol.)

The EUSART module generates an RCxIF interrupt coincident with the wake-up event. The interrupt is generated synchronously to the Q clocks in normal CPU operating modes as shown in [Figure 36-7](#), and asynchronously if the device is in Sleep mode as shown in [Figure 36-8](#). The interrupt condition is cleared by reading the RCxREG register.

The WUE bit is automatically cleared by the low-to-high transition on the RX line at the end of the Break. This signals to the user that the Break event is over. At this point, the EUSART module is in Idle mode waiting to receive the next character.

#### **36.2.3.1 Special Considerations**

##### Break Character

To avoid character errors or character fragments during a wake-up event, the wake-up character must be all zeros.

When the wake-up is enabled the function works independent of the low time on the data stream. If the WUE bit is set and a valid non-zero character is received, the low time from the Start bit to the first rising edge will be interpreted as the wake-up event. The remaining bits in the character will be received as a fragmented character and subsequent characters can result in framing or overrun errors.

Therefore, the initial character in the transmission must be all '0's. This must be ten or more bit times, 13-bit times recommended for LIN bus, or any number of bit times for standard RS-232 devices.

##### Oscillator Start-up Time

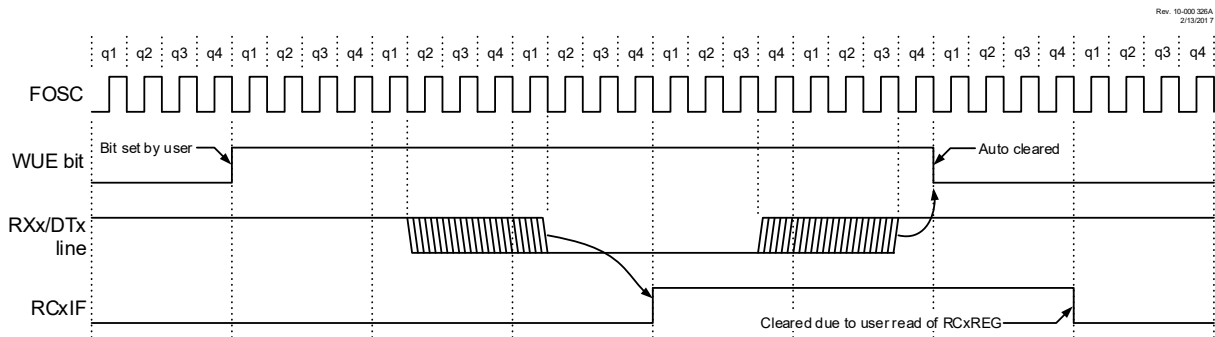
Oscillator start-up time must be considered, especially in applications using oscillators with longer start-up intervals (i.e., LP, XT or HS/PLL mode). The Sync Break (or wake-up signal) character must be of sufficient length, and be followed by a sufficient interval, to allow enough time for the selected oscillator to start and provide proper initialization of the EUSART.

##### WUE Bit

The wake-up event causes a receive interrupt by setting the RCxIF bit. The WUE bit is cleared in hardware by a rising edge on RX/DT. The interrupt condition is then cleared in software by reading the RCxREG register and discarding its contents.

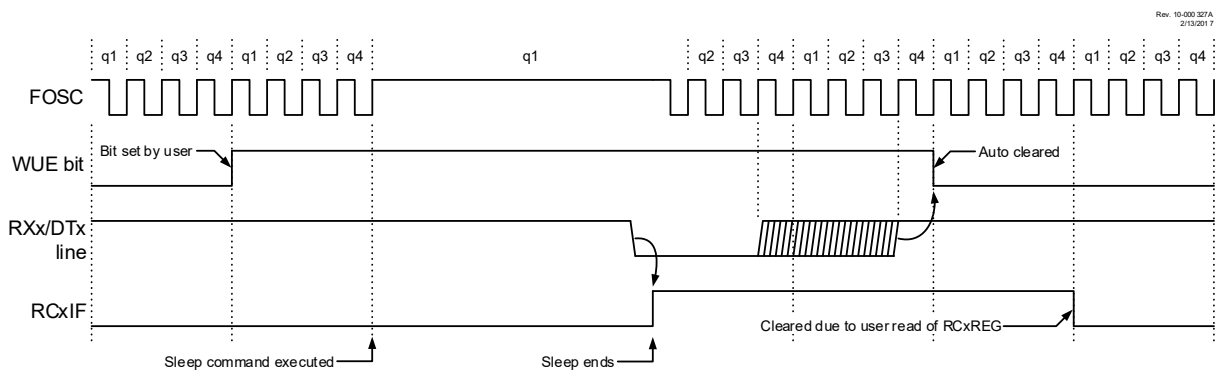
To ensure that no actual data is lost, check the RCIDL bit to verify that a receive operation is not in process before setting the WUE bit. If a receive operation is not occurring, the WUE bit may then be set just prior to entering the Sleep mode.

**Figure 36-7. Auto-Wake-up Bit (WUE) Timing During Normal Operation**



**Note 1:** The EUSART remains in idle while the WUE bit is set.

**Figure 36-8. Auto-Wake-up Bit (WUE) Timings During Sleep**



**Note 1:** The EUSART remains in idle while the WUE bit is set.

### 36.2.4 Break Character Sequence

The EUSART module has the capability of sending the special Break character sequences that are required by the LIN bus standard. A Break character consists of a Start bit, followed by 12 '0' bits and a Stop bit.

To send a Break character, set the SENDB and TXEN bits of the TXxSTA register. The Break character transmission is then initiated by a write to the TXxREG. The value of data written to TXxREG will be ignored and all '0's will be transmitted.

The SENDB bit is automatically reset by hardware after the corresponding Stop bit is sent. This allows the user to preload the transmit FIFO with the next transmit byte following the Break character (typically, the Sync character in the LIN specification).

The TRMT bit of the TXxSTA register indicates when the transmit operation is active or idle, just as it does during normal transmission. See [Figure 36-9](#) for more detail.

#### 36.2.4.1 Break and Sync Transmit Sequence

The following sequence will start a message frame header made up of a Break, followed by an auto-baud Sync byte. This sequence is typical of a LIN bus master.

1. Configure the EUSART for the desired mode.
2. Set the TXEN and SENDB bits to enable the Break sequence.
3. Load the TXxREG with a dummy character to initiate transmission (the value is ignored).

4. Write '55h' to TXxREG to load the Sync character into the transmit FIFO buffer.
5. After the Break has been sent, the SENDB bit is reset by hardware and the Sync character is then transmitted.

When the TXxREG becomes empty, as indicated by the TXxIF, the next data byte can be written to TXxREG.

### 36.2.5 Receiving a Break Character

The EUSART module can receive a Break character in two ways.

The first method to detect a Break character uses the FERR bit of the RCxSTA register and the received data as indicated by RCxREG. The Baud Rate Generator is assumed to have been initialized to the expected baud rate.

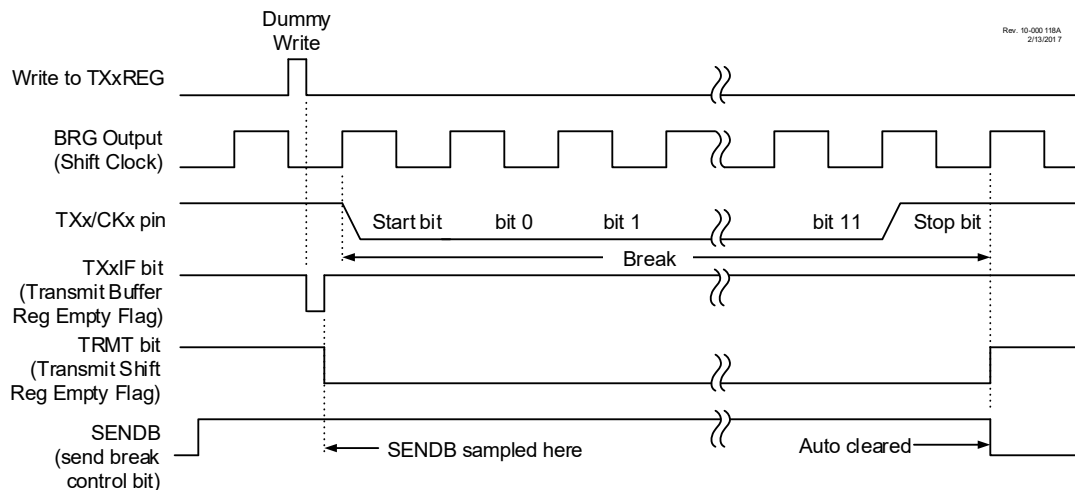
A Break character has been received when all three of the following conditions are true:

- RCxIF bit is set
- FERR bit is set
- RCxREG = 00h

The second method uses the Auto-Wake-up feature described in [36.2.3 Auto-Wake-up on Break](#). By enabling this feature, the EUSART will sample the next two transitions on RX/DT, cause an RCxIF interrupt, and receive the next data byte followed by another interrupt.

Note that following a Break character, the user will typically want to enable the Auto-Baud Detect feature. For both methods, the user can set the ABDEN bit of the BAUDxCON register before placing the EUSART in Sleep mode.

**Figure 36-9. Send Break Character Sequence**



## 36.3 EUSART Synchronous Mode

Synchronous serial communications are typically used in systems with a single master and one or more slaves. The master device contains the necessary circuitry for baud rate generation and supplies the clock for all devices in the system. Slave devices can take advantage of the master clock by eliminating the internal clock generation circuitry.

There are two signal lines in Synchronous mode: a bidirectional data line and a clock line. Slaves use the external clock supplied by the master to shift the serial data into and out of their respective receive and transmit shift registers. Since the data line is bidirectional, synchronous operation is half-duplex only. Half-duplex refers to the fact that master and slave devices can receive and transmit data but not both simultaneously. The EUSART can operate as either a master or slave device.

Start and Stop bits are not used in synchronous transmissions.

### 36.3.1 Synchronous Master Mode

The following bits are used to configure the EUSART for synchronous master operation:

- SYNC = 1 (configures the EUSART for synchronous operation)
- CSRC = 1 (configures the EUSART as the master)
- SREN = 0 (for transmit); SREN = 1 (recommended setting to receive 1 byte)
- CREN = 0 (for transmit); CREN = 1 (to receive continuously)
- SPEN = 1 (enables the EUSART)



**Important:** Clearing the SREN and CREN bits of the RCxSTA register ensures that the device is in the Transmit mode, otherwise the device will be configured to receive.

---

#### 36.3.1.1 Master Clock

Synchronous data transfers use a separate clock line, which is synchronous with the data. A device configured as a master transmits the clock on the TX/CK line. The TXx/CKx pin output driver is automatically enabled when the EUSART is configured for synchronous transmit or receive operation. Serial data bits change on the leading edge to ensure they are valid at the trailing edge of each clock. One clock cycle is generated for each data bit. Only as many clock cycles are generated as there are data bits.

#### 36.3.1.2 Clock Polarity

A clock polarity option is provided for Microwire compatibility. Clock polarity is selected with the SCKP bit of the BAUDxCON register. Setting the SCKP bit sets the clock Idle state as high. When the SCKP bit is set, the data changes on the falling edge of each clock. Clearing the SCKP bit sets the Idle state as low. When the SCKP bit is cleared, the data changes on the rising edge of each clock.

#### 36.3.1.3 Synchronous Master Transmission

Data is transferred out of the device on the RXx/DTx pin. The RXx/DTx and TXx/CKx pin output drivers are automatically enabled when the EUSART is configured for synchronous master transmit operation.

A transmission is initiated by writing a character to the TXxREG register. If the TSR still contains all or part of a previous character the new character data is held in the TXxREG until the last bit of the previous character has been transmitted. If this is the first character, or the previous character has been completely flushed from the TSR, the data in the TXxREG is immediately transferred to the TSR. The transmission of the character commences immediately following the transfer of the data to the TSR from the TXxREG.

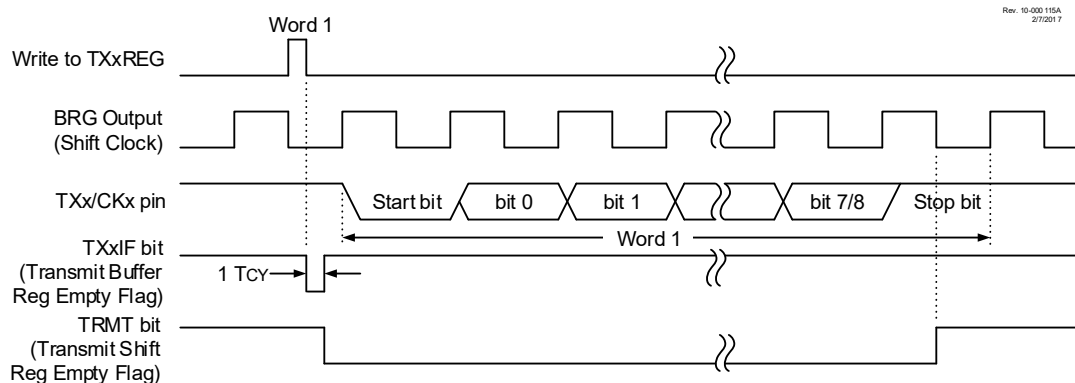
Each data bit changes on the leading edge of the master clock and remains valid until the subsequent leading clock edge.

**Note:** The TSR register is not mapped in data memory, so it is not available to the user.

### 36.3.1.4 Synchronous Master Transmission Setup

1. Initialize the SPxBRGH, SPxBRGL register pair and the BRG16 bit to achieve the desired baud rate (see [36.2 EUSART Baud Rate Generator \(BRG\)](#)).
2. Select the transmit output pin by writing the appropriate values to the RxyPPS register and RXxPPS register. Both selections should enable the same pin.
3. Select the clock output pin by writing the appropriate values to the RxyPPS register and CKxPPS register. Both selections should enable the same pin.
4. Enable the synchronous master serial port by setting bits SYNC, SPEN and CSRC.
5. Disable Receive mode by clearing bits SREN and CREN.
6. Enable Transmit mode by setting the TXEN bit.
7. If 9-bit transmission is desired, set the TX9 bit.
8. If interrupts are desired, set the TXxIE bit of the PIEx register and the GIE and PEIE bits of the INTCON register.
9. If 9-bit transmission is selected, the ninth bit should be loaded in the TX9D bit.
10. Start transmission by loading data to the TXxREG register.

**Figure 36-10. Synchronous Transmission**



### 36.3.1.5 Synchronous Master Reception

Data is received at the RXx/DTx pin. The RXx/DTx pin output driver is automatically disabled when the EUSART is configured for synchronous master receive operation.

In Synchronous mode, reception is enabled by setting either the Single Receive Enable bit (SREN of the RCxSTA register) or the Continuous Receive Enable bit (CREN of the RCxSTA register).

When SREN is set and CREN is clear, only as many clock cycles are generated as there are data bits in a single character. The SREN bit is automatically cleared at the completion of one character. When CREN is set, clocks are continuously generated until CREN is cleared. If CREN is cleared in the middle of a character the CK clock stops immediately and the partial character is discarded. If SREN and CREN are both set, then SREN is cleared at the completion of the first character and CREN takes precedence.

To initiate reception, set either SREN or CREN. Data is sampled at the RXx/DTx pin on the trailing edge of the TX/CK clock pin and is shifted into the Receive Shift Register (RSR). When a complete character is received into the RSR, the RCxIF bit is set and the character is automatically transferred to the two character receive FIFO. The Least Significant eight bits of the top character in the receive FIFO are available in RCxREG. The RCxIF bit remains set as long as there are unread characters in the receive FIFO.



**Note:** If the RX/DT function is on an analog pin, the corresponding ANSEL bit must be cleared for the receiver to function.

#### **36.3.1.6 Receive Overrun Error**

The receive FIFO buffer can hold two characters. An overrun error will be generated if a third character, in its entirety, is received before RCxREG is read to access the FIFO. When this happens the OERR bit of the RCxSTA register is set. Previous data in the FIFO will not be overwritten. The two characters in the FIFO buffer can be read, however, no additional characters will be received until the error is cleared. The OERR bit can only be cleared by clearing the overrun condition. If the overrun error occurred when the SREN bit is set and CREN is clear then the error is cleared by reading RCxREG. If the overrun occurred when the CREN bit is set then the error condition is cleared by either clearing the CREN bit of the RCxSTA register or by clearing the SPEN bit which resets the EUSART.

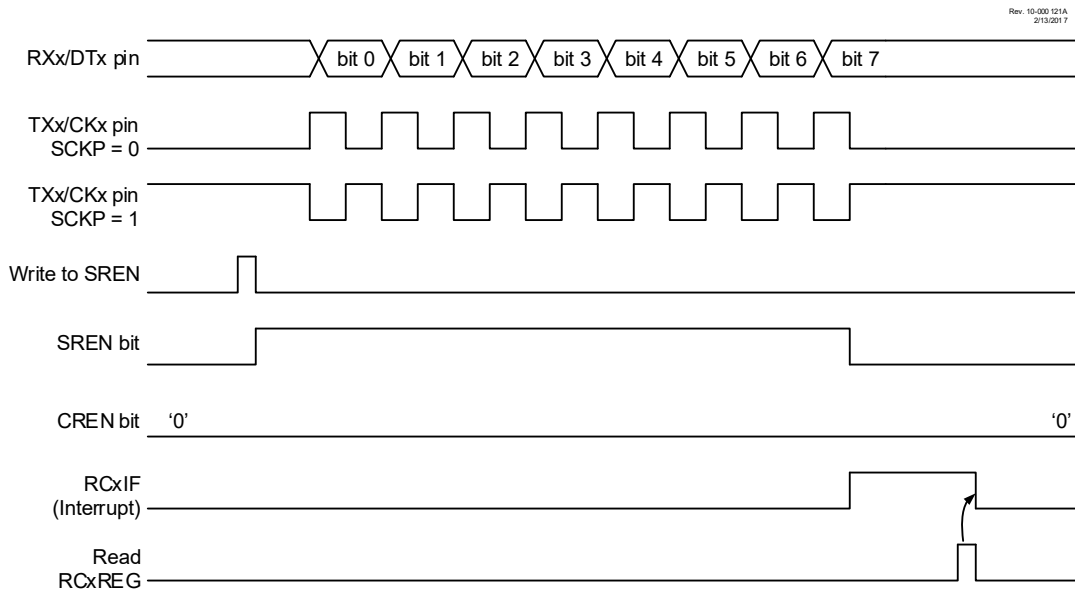
#### **36.3.1.7 Receiving 9-Bit Characters**

The EUSART supports 9-bit character reception. When the RX9 bit of the RCxSTA register is set the EUSART will shift nine bits into the RSR for each character received. The RX9D bit of the RCxSTA register is the ninth, and Most Significant, data bit of the top unread character in the receive FIFO. When reading 9-bit data from the receive FIFO buffer, the RX9D data bit must be read before reading the eight Least Significant bits from the RCxREG.

#### **36.3.1.8 Synchronous Master Reception Setup**

1. Initialize the SPxBRGH:SPxBRGL register pair and set or clear the BRG16 bit, as required, to achieve the desired baud rate.
2. Select the receive input pin by writing the appropriate values to the RxyPPS register and RXxPPS register. Both selections should enable the same pin.
3. Select the clock output pin by writing the appropriate values to the RxyPPS register and CKxPPS register. Both selections should enable the same pin.
4. Clear the ANSEL bit for the RXx pin (if applicable).
5. Enable the synchronous master serial port by setting bits SYNC, SPEN and CSRC.
6. Ensure bits CREN and SREN are clear.
7. If interrupts are desired, set the RCxIE bit of the PIEx register and the GIE and PEIE bits of the INTCON register.
8. If 9-bit reception is desired, set bit RX9.
9. Start reception by setting the SREN bit or for continuous reception, set the CREN bit.
10. Interrupt flag bit RCxIF will be set when reception of a character is complete. An interrupt will be generated if the enable bit RCxIE was set.
11. Read the RCxSTA register to get the ninth bit (if enabled) and determine if any error occurred during reception.
12. Read the 8-bit received data by reading the RCxREG register.
13. If an overrun error occurs, clear the error by either clearing the CREN bit of the RCxSTA register or by clearing the SPEN bit which resets the EUSART.

**Figure 36-11. Synchronous Reception (Master Mode, SREN)**



### 36.3.2 Synchronous Slave Mode

The following bits are used to configure the EUSART for synchronous slave operation:

- SYNC = 1 (configures the EUSART for synchronous operation.)
- CSRC = 0 (configures the EUSART as a slave)
- SREN = 0 (for transmit); SREN = 1 (for single byte receive)
- CREN = 0 (for transmit); CREN = 1 (recommended setting for continuous receive)
- SPEN = 1 (enables the EUSART)



**Important:** Clearing the SREN and CREN bits of the RCxSTA register ensures that the device is in the Transmit mode, otherwise the device will be configured to receive.

#### 36.3.2.1 Slave Clock

Synchronous data transfers use a separate clock line, which is synchronous with the data. A device configured as a slave receives the clock on the TX/CK line. The TXx/CKx pin output driver is automatically disabled when the device is configured for synchronous slave transmit or receive operation. Serial data bits change on the leading edge to ensure they are valid at the trailing edge of each clock. One data bit is transferred for each clock cycle. Only as many clock cycles should be received as there are data bits.



**Important:** If the device is configured as a slave and the TX/CK function is on an analog pin, the corresponding ANSEL bit must be cleared.

### 36.3.2.2 EUSART Synchronous Slave Transmit

The operation of the Synchronous Master and Slave modes are identical (see [36.3.1.3 Synchronous Master Transmission](#)), except in the case of the Sleep mode.

If two words are written to the TXxREG and then the SLEEP instruction is executed, the following will occur:

1. The first character will immediately transfer to the TSR register and transmit.
2. The second word will remain in the TXxREG register.
3. The TXxIF bit will not be set.
4. After the first character has been shifted out of TSR, the TXxREG register will transfer the second character to the TSR and the TXxIF bit will now be set.
5. If the PEIE and TXxIE bits are set, the interrupt will wake the device from Sleep and execute the next instruction. If the GIE bit is also set, the program will call the Interrupt Service Routine.

### 36.3.2.3 Synchronous Slave Transmission Setup

1. Set the SYNC and SPEN bits and clear the CSRC bit.
2. Select the transmit output pin by writing the appropriate values to the RxyPPS register and RXxPPS register. Both selections should enable the same pin.
3. Select the clock input pin by writing the appropriate value to the CKxPPS register.
4. Clear the ANSEL bit for the CKx pin (if applicable).
5. Clear the CREN and SREN bits.
6. If interrupts are desired, set the TXxIE bit of the PIEx register and the GIE and PEIE bits of the INTCON register.
7. If 9-bit transmission is desired, set the TX9 bit.
8. Enable transmission by setting the TXEN bit.
9. If 9-bit transmission is selected, insert the Most Significant bit into the TX9D bit.
10. Prepare for transmission by writing the Least Significant eight bits to the TXxREG register. The word will be transmitted in response to the Master clocks at the CKx pin.

### 36.3.2.4 EUSART Synchronous Slave Reception

The operation of the Synchronous Master and Slave modes is identical (see [36.3.1.5 Synchronous Master Reception](#)), with the following exceptions:

- Sleep
- CREN bit is always set, therefore the receiver is never idle
- SREN bit, which is a “don’t care” in Slave mode

A character may be received while in Sleep mode by setting the CREN bit prior to entering Sleep. Once the word is received, the RSR register will transfer the data to the RCxREG register. If the RCxIE enable bit is set, the interrupt generated will wake the device from Sleep and execute the next instruction. If the GIE bit is also set, the program will branch to the interrupt vector.

### 36.3.2.5 Synchronous Slave Reception Setup:

1. Set the SYNC and SPEN bits and clear the CSRC bit.
2. Select the receive input pin by writing the appropriate value to the RXxPPS register.
3. Select the clock input pin by writing the appropriate values to the CKxPPS register.
4. Clear the ANSEL bit for both the TXx/CKx and RXx/DTx pins (if applicable).
5. If interrupts are desired, set the RCxIE bit of the PIEx register and the GIE and PEIE bits of the INTCON register.

6. If 9-bit reception is desired, set the RX9 bit.
7. Set the CREN bit to enable reception.
8. The RCxIF bit will be set when reception is complete. An interrupt will be generated if the RCxIE bit was set.
9. If 9-bit mode is enabled, retrieve the Most Significant bit from the RX9D bit of the RCxSTA register.
10. Retrieve the eight Least Significant bits from the receive FIFO by reading the RCxREG register.
11. If an overrun error occurs, clear the error by either clearing the CREN bit of the RCxSTA register or by clearing the SPEN bit which resets the EUSART.

## **36.4 EUSART Operation During Sleep**

The EUSART will remain active during Sleep only in the Synchronous Slave mode. All other modes require the system clock and therefore cannot generate the necessary signals to run the Transmit or Receive Shift registers during Sleep.

Synchronous Slave mode uses an externally generated clock to run the Transmit and Receive Shift registers.

### **36.4.1 Synchronous Receive During Sleep**

To receive during Sleep, all the following conditions must be met before entering Sleep mode:

- RCxSTA and TXxSTA Control registers must be configured for Synchronous Slave Reception (see [36.3.2.5 Synchronous Slave Reception Setup](#)).
- If interrupts are desired, set the RCxIE bit of the PEx register and the GIE and PEIE bits of the INTCON register.
- The RCxIF interrupt flag must be cleared by reading RCxREG to unload any pending characters in the receive buffer.

Upon entering Sleep mode, the device will be ready to accept data and clocks on the RXx/DTx and TXx/CKx pins, respectively. When the data word has been completely clocked in by the external device, the RCxIF interrupt flag bit of the PIRx register will be set. Thereby, waking the processor from Sleep.

Upon waking from Sleep, the instruction following the `SLEEP` instruction will be executed. If the Global Interrupt Enable (GIE) bit of the INTCON register is also set, then the Interrupt Service Routine at address 004h will be called.

### **36.4.2 Synchronous Transmit During Sleep**

To transmit during Sleep, all the following conditions must be met before entering Sleep mode:

- The RCxSTA and TXxSTA Control registers must be configured for synchronous slave transmission (see [36.3.2.3 Synchronous Slave Transmission Setup](#)).
- The TXxIF interrupt flag must be cleared by writing the output data to the TXxREG, thereby filling the TSR and transmit buffer.
- Interrupt enable bits TXxIE of the PEx register and PEIE of the INTCON register must set.
- If interrupts are desired, set the GIE bit of the INTCON register.

Upon entering Sleep mode, the device will be ready to accept clocks on the TXx/CKx pin and transmit data on the RXx/DTx pin. When the data word in the TSR has been completely clocked out by the external device, the pending byte in the TXxREG will transfer to the TSR and the TXxIF flag will be set. Thereby, waking the processor from Sleep. At this point, the TXxREG is available to accept another character for transmission. Writing TXxREG will clear the TXxIF flag.

# PIC16(L)F18455/56

## (EUSART) Enhanced Universal Synchronous Asyn...

---

---

Upon waking from Sleep, the instruction following the `SLEEP` instruction will be executed. If the Global Interrupt Enable (GIE) bit is also set then the Interrupt Service Routine at address 0004h will be called.

### 36.5 Register Summary - EUSART

Address	Name	Bit Pos.								
0x0119	RC1REG	7:0	RCREG[7:0]							
0x011A	TX1REG	7:0	TXREG[7:0]							
0x011B	SP1BRG	7:0	SPBRGL[7:0]							
		15:8	SPBRGH[7:0]							
0x011D	RC1STA	7:0	SPEN	RX9	SREN	CREN	ADDEN	FERR	OERR	RX9D
0x011E	TX1STA	7:0	CSRC	TX9	TXEN	SYNC	SENDB	BRGH	TRMT	TX9D
0x011F	BAUD1CON	7:0	ABDOVF	RCIDL		SCKP	BRG16		WUE	ABDEN
0x0120 ... 0x0A18	Reserved									
0x0A19	RC2REG	7:0	RCREG[7:0]							
0x0A1A	TX2REG	7:0	TXREG[7:0]							
0x0A1B	SP2BRG	7:0	SPBRGL[7:0]							
		15:8	SPBRGH[7:0]							
0x0A1D	RC2STA	7:0	SPEN	RX9	SREN	CREN	ADDEN	FERR	OERR	RX9D
0x0A1E	TX2STA	7:0	CSRC	TX9	TXEN	SYNC	SENDB	BRGH	TRMT	TX9D
0x0A1F	BAUD2CON	7:0	ABDOVF	RCIDL		SCKP	BRG16		WUE	ABDEN

### 36.6 Register Definitions: EUSART Control

### 36.6.1 RCxSTA

**Name:** RCxSTA  
**Address:** 0x11D,0xA1D

Receive Status and Control Register

Bit	7	6	5	4	3	2	1	0
	SPEN	RX9	SREN	CREN	ADDEN	FERR	OERR	RX9D
Access	R/W	R/W	R/W	R/W	R/W	RO	R/HC	R/HC
Reset	0	0	0	0	0	0	0	0

#### Bit 7 – SPEN Serial Port Enable bit

Value	Description
1	Serial port enabled
0	Serial port disabled (held in Reset)

#### Bit 6 – RX9 9-Bit Receive Enable bit

Value	Description
1	Selects 9-bit reception
0	Selects 8-bit reception

#### Bit 5 – SREN Single Receive Enable bit

Controls reception. This bit is cleared by hardware when reception is complete

Value	Condition	Description
1	$SYNC = 1$ AND $CSRC = 1$	Start single receive
0	$SYNC = 1$ AND $CSRC = 1$	Single receive is complete
X	$SYNC = 0$ OR $CSRC = 0$	Don't care

#### Bit 4 – CREN Continuous Receive Enable bit

Value	Condition	Description
1	$SYNC = 1$	Enables continuous receive until enable bit CREN is cleared (CREN overrides SREN)
0	$SYNC = 1$	Disables continuous receive
1	$SYNC = 0$	Enables receiver
0	$SYNC = 0$	Disables receiver

#### Bit 3 – ADDEN Address Detect Enable bit

Value	Condition	Description
1	$SYNC = 0$ AND $RX9 = 1$	The receive buffer is loaded and the interrupt occurs only when the ninth received bit is set
0	$SYNC = 0$ AND $RX9 = 1$	All bytes are received and interrupt always occurs. Ninth bit can be used as parity bit
X	$RX9 = 0$ OR $SYNC = 1$	Don't care

**Bit 2 – FERR** Framing Error bit

Value	Description
1	Unread byte in <a href="#">36.6.5 RCxREG</a> has a framing error
0	Unread byte in <a href="#">36.6.5 RCxREG</a> does not have a framing error

**Bit 1 – OERR** Overrun Error bit

Value	Description
1	Overrun error (can be cleared by clearing either <a href="#">SPEN</a> or <a href="#">CREN</a> bit)
0	No overrun error

**Bit 0 – RX9D** Ninth bit of Received Data

This can be address/data bit or a parity bit which is determined by user firmware.



### 36.6.2 TXxSTA

**Name:** TXxSTA  
**Address:** 0x11E,0xA1E

Transmit Status and Control Register

Bit	7	6	5	4	3	2	1	0
	CSRC	TX9	TXEN	SYNC	SENDB	BRGH	TRMT	TX9D
Access	R/W	R/W	R/W	R/W	R/W	R/W	RO	R/W
Reset	0	0	0	0	0	0	1	0

**Bit 7 – CSRC** Clock Source Select bit

Value	Condition	Description
1	SYNC= 1	Master mode (clock generated internally from BRG)
0	SYNC= 1	Slave mode (clock from external source)
X	SYNC= 0	Don't care

**Bit 6 – TX9** 9-bit Transmit Enable bit

Value	Description
1	Selects 9-bit transmission
0	Selects 8-bit transmission

**Bit 5 – TXEN** Transmit Enable bit  
Enables transmitter<sup>(1)</sup>

Value	Description
1	Transmit enabled
0	Transmit disabled

**Bit 4 – SYNC** EUSART Mode Select bit

Value	Description
1	Synchronous mode
0	Asynchronous mode

**Bit 3 – SENDB** Send Break Character bit

Value	Condition	Description
1	SYNC= 0	Send Sync Break on next transmission (cleared by hardware upon completion)
0	SYNC= 0	Sync Break transmission disabled or completed
X	SYNC= 1	Don't care

**Bit 2 – BRGH** High Baud Rate Select bit

# PIC16(L)F18455/56

## (EUSART) Enhanced Universal Synchronous Asyn...

Value	Condition	Description
1	SYNC= 0	High speed, if BRG16 = 1, baud rate is baudclk/4; else baudclk/16
0	SYNC= 0	Low speed
X	SYNC= 1	Don't care

**Bit 1 – TRMT** Transmit Shift Register (TSR) Status bit

Value	Description
1	TSR is empty
0	TSR is not empty

**Bit 0 – TX9D** Ninth bit of Transmit Data

Can be address/data bit or a parity bit.

**Note:**

1. **SREN** and **CREN** bits override TXEN in Sync mode.

### 36.6.3 BAUDxCON

**Name:** BAUDxCON  
**Address:** 0x11F,0xA1F

Baud Rate Control Register

Bit	7	6	5	4	3	2	1	0
	ABDOVF	RCIDL		SCKP	BRG16		WUE	ABDEN
Access	RO	RO		RW	RW		RW	RW
Reset	0	0		0	0		0	0

**Bit 7 – ABDOVF** Auto-Baud Detect Overflow bit

Value	Condition	Description
1	SYNC= 0	Auto-baud timer overflowed
0	SYNC= 0	Auto-baud timer did not overflow
X	SYNC= 1	Don't care

**Bit 6 – RCIDL** Receive Idle Flag bit

Value	Condition	Description
1	SYNC= 0	Receiver is Idle
0	SYNC= 0	Start bit has been received and the receiver is receiving
X	SYNC= 1	Don't care

**Bit 4 – SCKP** Synchronous Clock Polarity Select bit

Value	Condition	Description
1	SYNC= 0	Idle state for transmit (TX) is a low level (transmit data inverted)
0	SYNC= 0	Idle state for transmit (TX) is a high level (transmit data is non-inverted)
1	SYNC= 1	Data is clocked on rising edge of the clock
0	SYNC= 1	Data is clocked on falling edge of the clock

**Bit 3 – BRG16** 16-bit Baud Rate Generator Select bit

Value	Description
1	16-bit Baud Rate Generator is used
0	8-bit Baud Rate Generator is used

**Bit 1 – WUE** Wake-up Enable bit

Value	Condition	Description
1	SYNC= 0	Receiver is waiting for a falling edge. Upon falling edge no character will be received and flag RCxIF will be set. WUE will automatically clear after RCxIF is set.
0	SYNC= 0	Receiver is operating normally
X	SYNC= 1	Don't care

**Bit 0 – ABDEN** Auto-Baud Detect Enable bit

# PIC16(L)F18455/56

## (EUSART) Enhanced Universal Synchronous Asyn...

Value	Condition	Description
1	SYNC= 0	Auto-Baud Detect mode is enabled (clears when auto-baud is complete)
0	SYNC= 0	Auto-Baud Detect is complete or mode is disabled
X	SYNC= 1	Don't care

**36.6.4 SPxBRG**

**Name:** SPxBRG  
**Address:** 0x11B,0xA1B

Baud Rate Determination Register

Bit	15	14	13	12	11	10	9	8
	SPBRGH[7:0]							
Access	R/W	R/W	R/W	R/W	R/W	R/W	R/W	R/W
Reset	0	0	0	0	0	0	0	0
Bit	7	6	5	4	3	2	1	0
	SPBRGL[7:0]							
Access	R/W	R/W	R/W	R/W	R/W	R/W	R/W	R/W
Reset	0	0	0	0	0	0	0	0

**Bits 15:8 – SPBRGH[7:0]** Baud Rate High Byte Register

**Bits 7:0 – SPBRGL[7:0]** Baud Rate Low Byte Register

**36.6.5 RCxREG**

**Name:** RCxREG  
**Address:** 0x119,0xA19

Receive Data Register

Bit	7	6	5	4	3	2	1	0
	RCREG[7:0]							
Access	RO	RO	RO	RO	RO	RO	RO	RO
Reset	0	0	0	0	0	0	0	0

**Bits 7:0 – RCREG[7:0]** Receive data

**36.6.6 TXxREG**

**Name:** TXxREG  
**Address:** 0x11A,0xA1A

Transmit Data Register

Bit	7	6	5	4	3	2	1	0
	TXREG[7:0]							
Access	R/W	R/W	R/W	R/W	R/W	R/W	R/W	R/W
Reset	0	0	0	0	0	0	0	0

**Bits 7:0 – TXREG[7:0]** Transmit Data

## 37. (SMT) Signal Measurement Timer

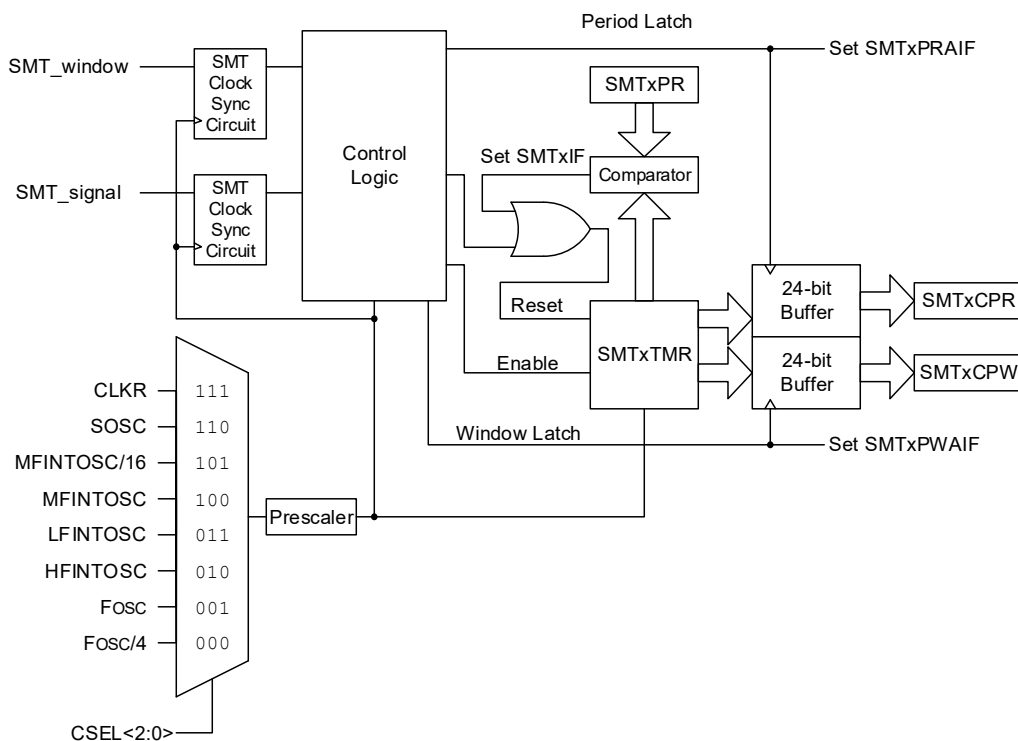
The SMT is a 24-bit counter with advanced clock and gating logic, which can be configured for measuring a variety of digital signal parameters such as pulse width, frequency and duty cycle, and the time difference between edges on two signals.

Features of the SMT include:

- 24-bit timer/counter
- Two 24-bit measurement capture registers
- One 24-bit period match register
- Multi-mode operation, including relative timing measurement
- Interrupt on period match and acquisition complete
- Multiple clock, signal and window sources

Below is the block diagram for the SMT module.

**Figure 37-1. Signal Measurement Timer Block Diagram**



Rev. 10-000181E  
10/12/2016

### 37.1 SMT Operation

#### 37.1.1 Clock Source Selection

The SMT clock source is selected by configuring the **CSEL** bits in the SMTxCLK register. The clock source can be prescaled using the **PS** bits of the SMTxCON0 register. The prescaled clock source is



used to clock both the counter and any synchronization logic used by the module. Refer the table below for possible clock source options.

The polarity of the clock source can be selected using the **CPOL** bit in the SMTxCON0 register.

**Table 37-1. SMT Clock Source Selection**

CSEL<2:0>	Clock Source
111	CLKREF output
110	SOSC
101	MFINTOSC (31.25kHz)
100	MFINTOSC (500kHz)
011	LFINTOSC
010	HFINTOSC
001	F <sub>osc</sub>
000	F <sub>osc</sub> /4

### 37.1.2 Signal and Window Source Selection

The SMT signal and window sources are selected by configuring the **SSEL** bits in the SMTxSIG register and the **WSEL** bits in the SMTxWIN register. Refer the tables below for the possible selections.

The polarity of the signal and window sources can be selected using the **SPOL** and **WPOL** bits in the SMTxCON0 register.

**Table 37-2. SMT Signal Selection**

SSEL<4:0>	SMT1 Signal Source	SMT2 Signal Source
11111-11000	Reserved	Reserved
10111	SMT2 overflow	SMT1 overflow
10110	CCP5OUT	CCP5OUT
10101	CLC4OUT	CLC4OUT
10100	CLC3OUT	CLC3OUT
10011	CLC2OUT	CLC2OUT
10010	CLC1OUT	CLC1OUT
10001	ZCDOUT	ZCDOUT
10000	C2OUT	C2OUT
01111	C1OUT	C1OUT
01110	NCO1OUT	NCO1OUT
01101	PWM7OUT	PWM7OUT
01100	PWM6OUT	PWM6OUT
01011	CCP4OUT	CCP4OUT

**PIC16(L)F18455/56**  
**(SMT) Signal Measurement Timer**

SSEL<4:0>	SMT1 Signal Source	SMT2 Signal Source
01010	CCP3OUT	CCP3OUT
01001	CCP2OUT	CCP2OUT
01000	CCP1OUT	CCP1OUT
00111	TMR6 postscaled output	TMR6 postscaled output
00110	TMR5 overflow	TMR5 overflow
00101	TMR4 postscaled output	TMR4 postscaled output
00100	TMR3 overflow	TMR3 overflow
00011	TMR2 postscaled output	TMR2 postscaled output
00010	TMR1 overflow	TMR1 overflow
00001	TMR0 overflow	TMR0 overflow
00000	Pin Selected by SMT1SIGPPS	Pin Selected by SMT2SIGPPS

**Table 37-3. SMT Window Selection**

WSEL<4:0>	SMT1 Window Source	SMT2 Window Source
11111-11001	Reserved	Reserved
11000	CCP5OUT	CCP5OUT
10111	NCO1OUT	NCO1OUT
10110	SMT2_overflow	SMT1_overflow
10101	CLKREFOUT	CLKREFOUT
10100	CLC4OUT	CLC4OUT
10011	CLC3OUT	CLC3OUT
10010	CLC2OUT	CLC2OUT
10001	CLC1OUT	CLC1OUT
10000	ZCDOUT	ZCDOUT
01111	C2OUT	C2OUT
01110	C1OUT	C1OUT
01101	PWM7OUT	PWM7OUT
01100	PWM6OUT	PWM6OUT
01011	CCP4OUT	CCP4OUT
01010	CCP3OUT	CCP3OUT
01001	CCP2OUT	CCP2OUT
01000	CCP1OUT	CCP1OUT

# PIC16(L)F18455/56

## (SMT) Signal Measurement Timer

WSEL<4:0>	SMT1 Window Source	SMT2 Window Source
00111	TMR6_postscaled_out	TMR6_postscaled_out
00110	TMR4_postscaled_out	TMR4_postscaled_out
00101	TMR2_postscaled_out	TMR2_postscaled_out
00100	TMR0_overflow	TMR0_overflow
00011	SOSC	SOSC
00010	MFINTOSC (31.25kHz)	MFINTOSC (31.25kHz)
00001	LFINTOSC (31.25kHz)	LFINTOSC (31.25kHz)
00000	Pin Selected by SMT1WINPPS	Pin Selected by SMT1WINPPS

### 37.1.3 Time Base

The SMTxTMR is the 24-bit counter/timer used for measurement in each of the modes of the SMT. It can be reset to 0x000000 by setting the **RST** bit of the SMTxSTAT register. It can be written to and read by software. It is not guarded for atomic access, therefore reads and writes to the SMTxTMR should be made when the **GO** = 0.

The counter can be prevented from a rollover using the **STP** bit in the SMTxCON0 register. When **STP** = 1, SMTxTMR will remain equal to SMTxPR. When **STP** = 0, SMTxTMR resets to 0x000000.

### 37.1.4 Capture Pulse Width and Period Registers

The SMTxCPW and SMTxCPR registers are used to latch in the value of the SMTxTMR based on the mode of SMT operation. These registers can also be updated with the current value of the SMTxTMR value by setting the **CPWUP** and **CPRUP** bits of the SMTxSTAT register, respectively.

### 37.1.5 Status Information

The SMT provides input status information for the user without requiring the need to deal with the polarity of the incoming signals.

**Go Status:** Timer run status is determined by the **TS** bit of the SMTxSTAT register, and will be delayed in time by synchronizer delays in non-Counter modes.

**Signal Status:** Signal status is determined by the **AS** bit of the SMTxSTAT register. This bit is used in all modes except Window Measure, Time of Flight and Capture modes, and is only valid when **TS** = 1, and will be delayed in time by synchronizer delays in non-Counter modes.

**Window Status:** Window status is determined by the **WS** bit of the SMTxSTAT register. This bit is only used in Windowed Measure, Gated Counter and Gated Window Measure modes, and is only valid when **TS** = 1, and will be delayed in time by synchronizer delays in non-Counter modes.

### 37.1.6 Modes of Operation

The modes of operation are mentioned in the table below. The following sections provide descriptions and examples of how the modes can be used. Note that all waveforms assume **WPOL/SPOL/CPOL** = 0. For all modes, the **REPEAT** bit controls whether the acquisition is repeated or single. When **REPEAT** = 0 (Single Acquisition mode), the timer will stop incrementing and the **SMTxGO** bit will be reset upon the completion of an acquisition. Otherwise, the timer will continue and allow for continued acquisitions to overwrite the previous ones until the timer is stopped in software.

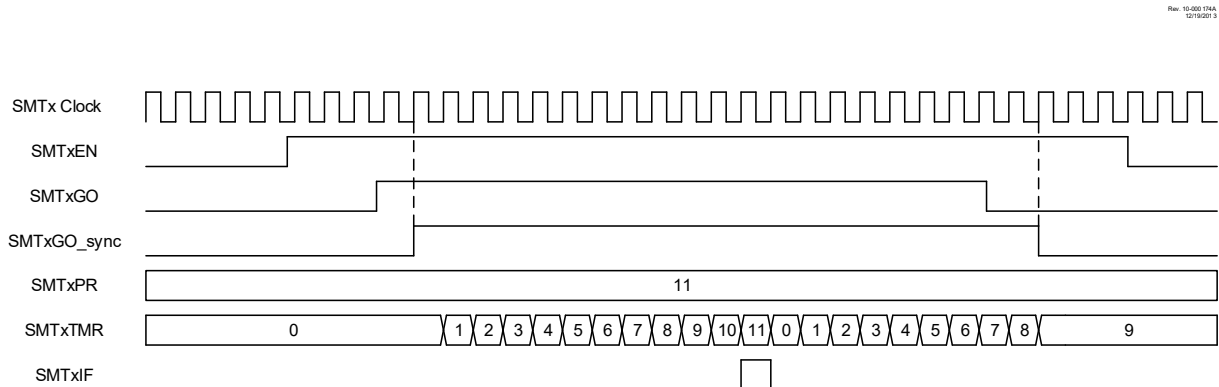
**Table 37-4. Modes of Operation**

<b>MODE</b>	<b>Mode of operation</b>	<b>Synchronous operation</b>
0000	Timer	Yes
0001	Gated Timer	Yes
0010	Period and Duty Cycle Measurement	Yes
0011	High and low time Measurement	Yes
0100	Windowed Measurement	Yes
0101	Gated Windowed Measurement	Yes
0110	Time of Flight Measurement	Yes
0111	Capture	Yes
1000	Counter	No
1001	Gated Counter	No
1010	Windowed Counter	No
1011-1111	Reserved	-

**37.1.6.1 Timer Mode**

Timer mode is the basic mode of operation where the SMTxTMR is used as a 24-bit timer. No data acquisition takes place in this mode. The timer increments as long as the SMTxGO bit has been set by software. No SMT window or SMT signal events affect the SMTxGO bit. Everything is synchronized to the SMT clock source. When the timer experiences a period match (SMTxTMR = SMTxPR), SMTxTMR is reset and the period match interrupt trips. See figure below.

**Figure 37-2. Timer Mode Timing Diagram**

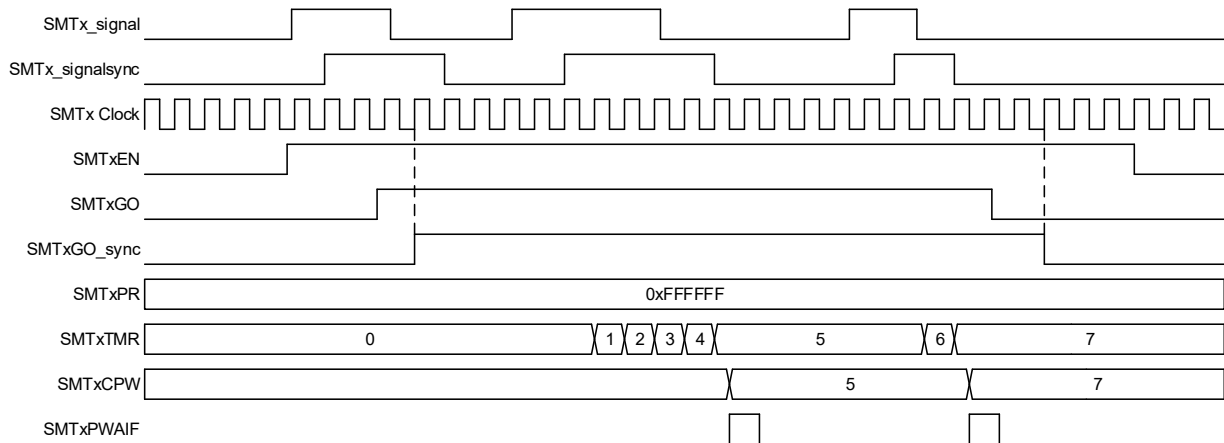


**37.1.6.2 Gated Timer Mode**

Gated Timer mode uses the signal input (SSEL) to control whether or not the SMTxTMR will increment. Upon a falling edge of the signal, the SMTxCPW register will update to the current value of the SMTxTMR. Example waveforms for both repeated and single acquisitions are provided in figures below.

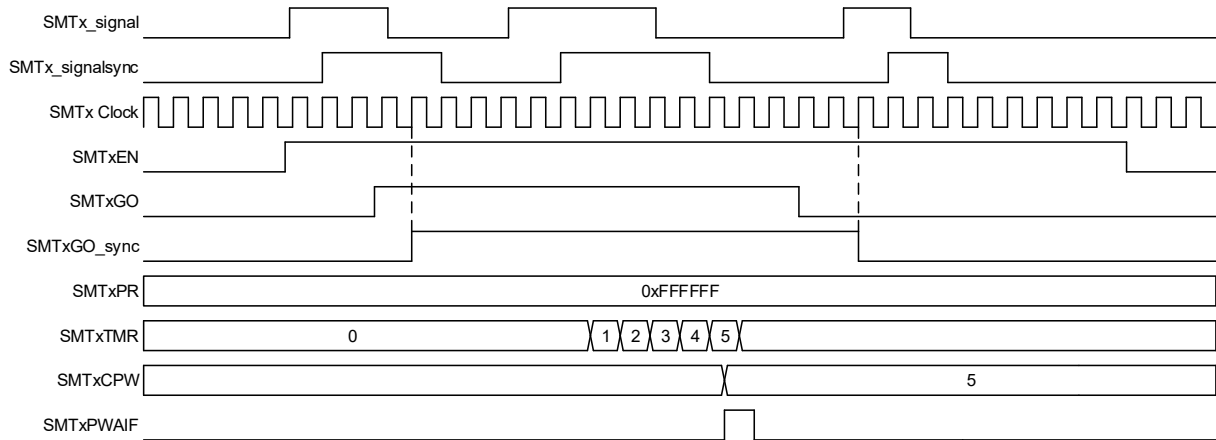
**Figure 37-3. Gated Timer Mode, Repeat Acquisition Timing Diagram**

Rev. 10-000-176A  
12/19/2013



**Figure 37-4. Gated Timer Mode, Single Acquisition Timing Diagram**

Rev. 10-000-176A  
12/19/2013

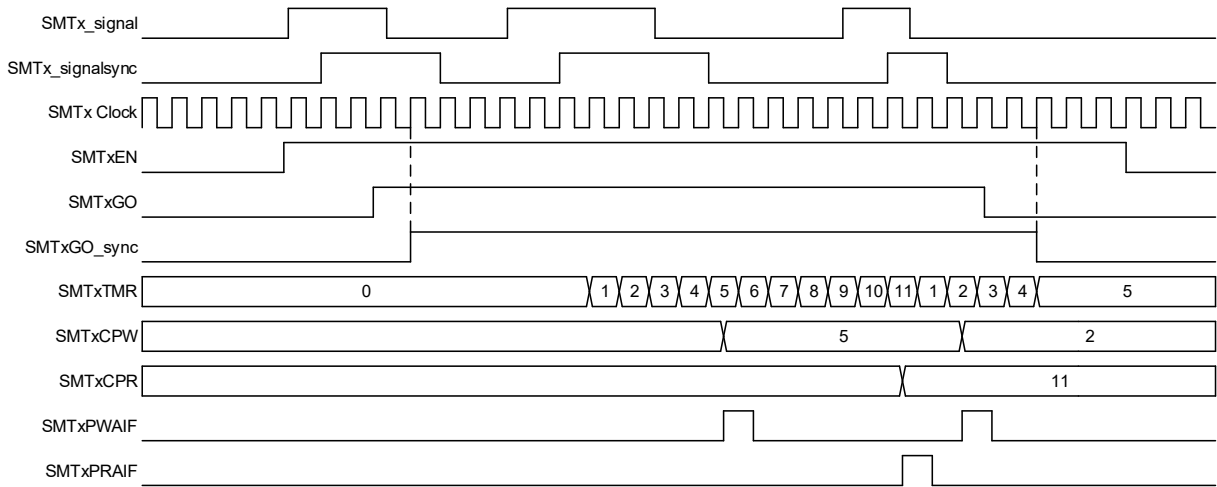


### 37.1.6.3 Period and Duty Cycle Measurement Mode

In this mode, either the duty cycle or period (depending on polarity) of the input signal can be acquired relative to the SMT clock. The CPW register is updated on a falling edge of the signal, and the CPR register is updated on a rising edge of the signal, along with the SMTxTMR resetting to 0x000001. In addition, the SMTxGO bit is reset on a rising edge when the SMT is in single acquisition mode. See figures below.

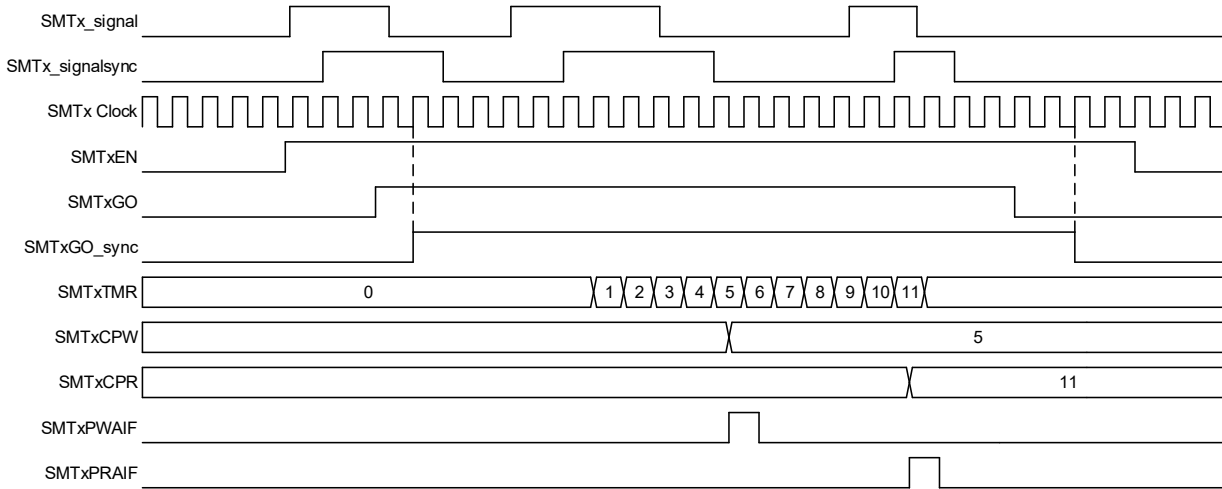
**Figure 37-5. Period and Duty-Cycle, Repeat Acquisition Mode Timing Diagram**

Rev. 10-000177A  
12/19/2013



**Figure 37-6. Period and Duty-Cycle, Single Acquisition Mode Timing Diagram**

Rev. 10-000178A  
12/19/2013

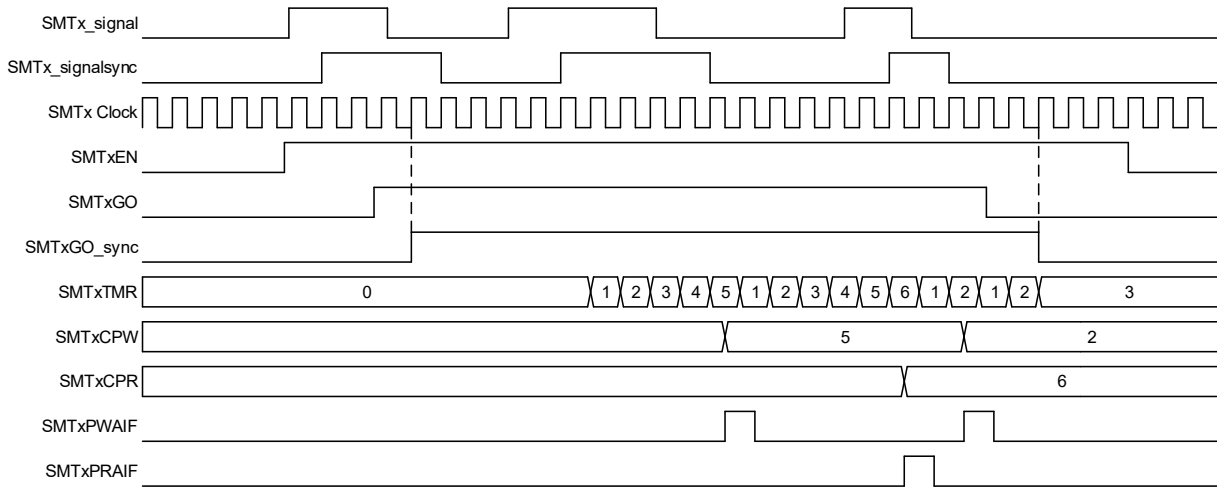


#### 37.1.6.4 High and Low Measurement Mode

This mode measures the high and low pulse time of the signal relative to the SMT clock. It begins incrementing the SMTxTMR on a rising edge on the input signal, then updates the SMTxCPW register with the value and resets the SMTxTMR on a falling edge, starting to increment again. Upon observing another rising edge, it updates the SMTxCPR register with its current value and once again resets the SMTxTMR value and begins incrementing again. See the figures below.

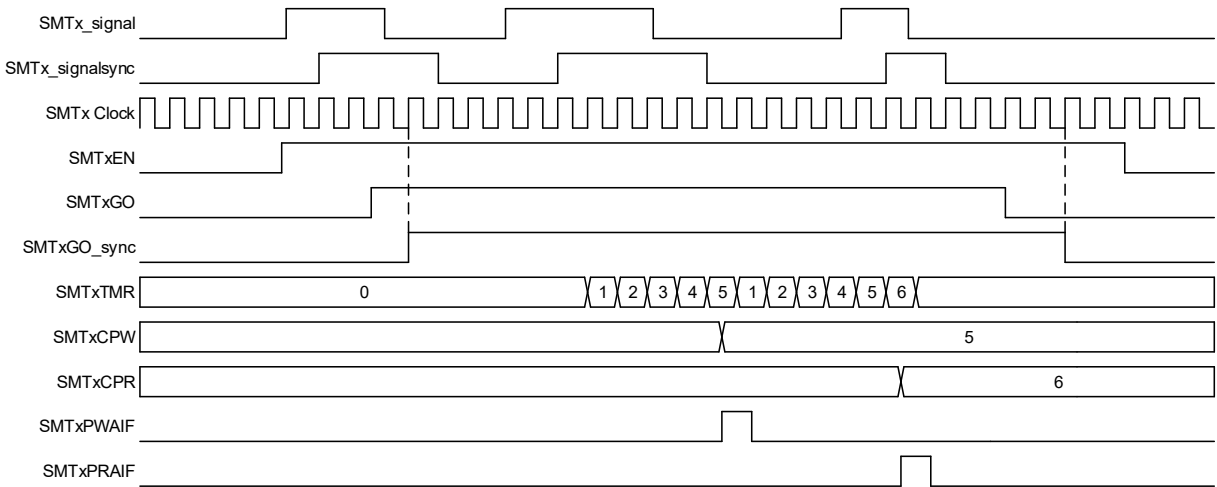
**Figure 37-7. High and Low Measurement Mode, Repeat Acquisition Timing Diagram**

Rev. 10-000 180A  
12/19/2013



**Figure 37-8. High and Low Measurement Mode, Single Acquisition Timing Diagram**

Rev. 10-000 179A  
12/19/2013

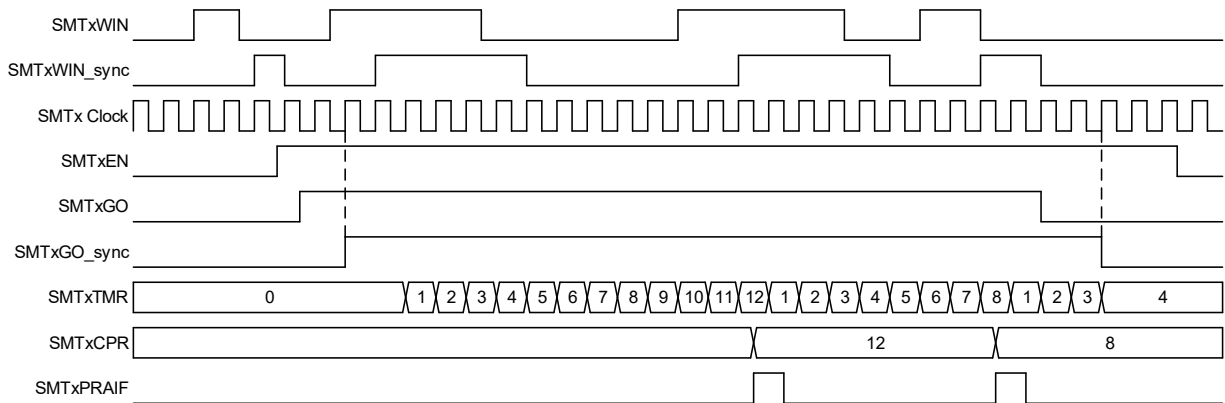


**37.1.6.5 Windowed Measurement Mode**

This mode measures the duration of the window input (**WSEL**) to the SMT. It begins incrementing the timer on a rising edge of the window input and updates the SMTxCPR register with the value of the timer and resets the timer on a second rising edge. See figures below.

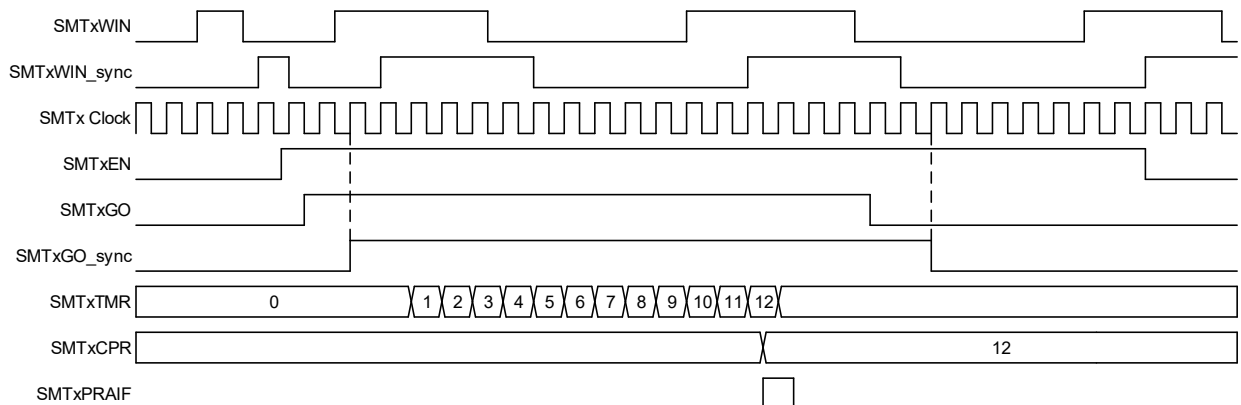
**Figure 37-9. Windowed Measurement Mode, Repeat Acquisition Timing Diagram**

Rev. 10-000 182A  
12/16/2013



**Figure 37-10. Windowed Measurement Mode, Single Acquisition Timing Diagram**

Rev. 10-000 181A  
12/16/2013



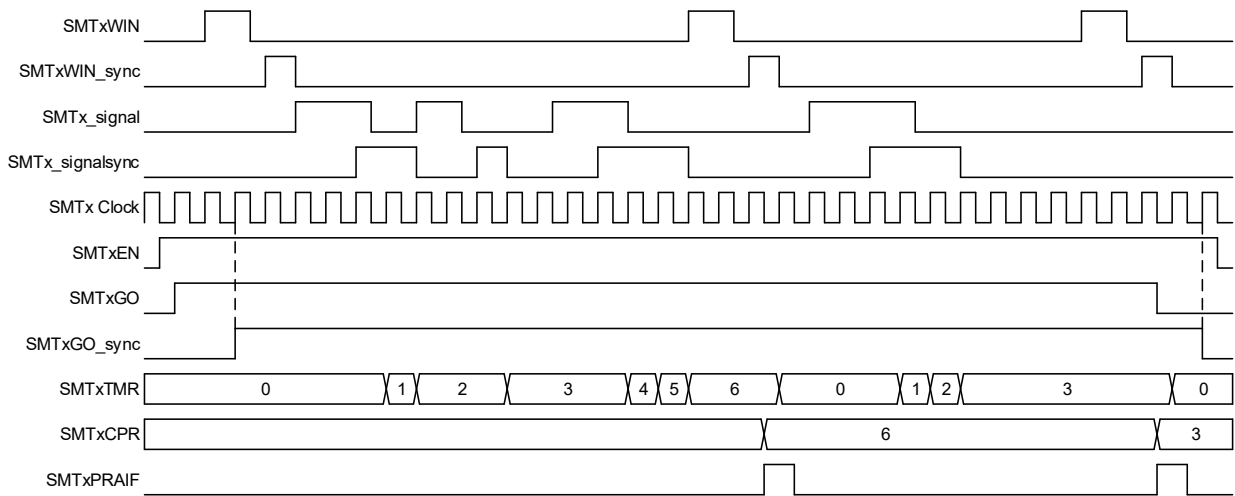
### 37.1.6.6 Gated Window Measurement Mode

This mode measures the duty cycle of the signal input over a known input window. It does so by incrementing the timer on each pulse of the clock signal while the signal input is high, updating the SMTxCPR register and resetting the timer on every rising edge of the window input after the first. See figures below.



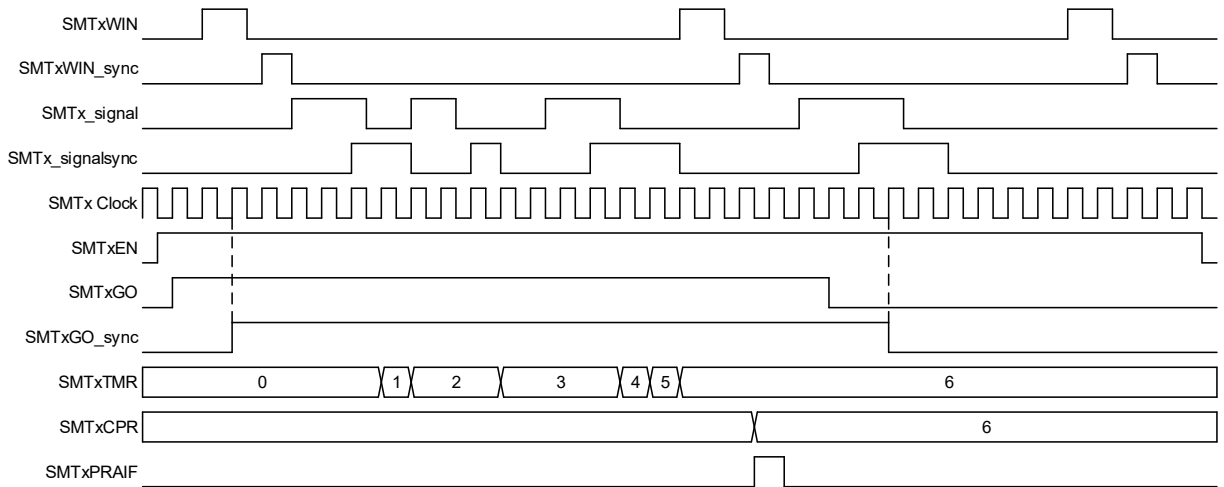
**Figure 37-11. Gated Windowed Measurement Mode, Repeat Acquisition Timing Diagram**

Rev. 10-000 184A  
12/10/2013



**Figure 37-12. Gated Windowed Measurement Mode, Single Acquisition Timing Diagram**

Rev. 10-000 184A  
12/10/2013

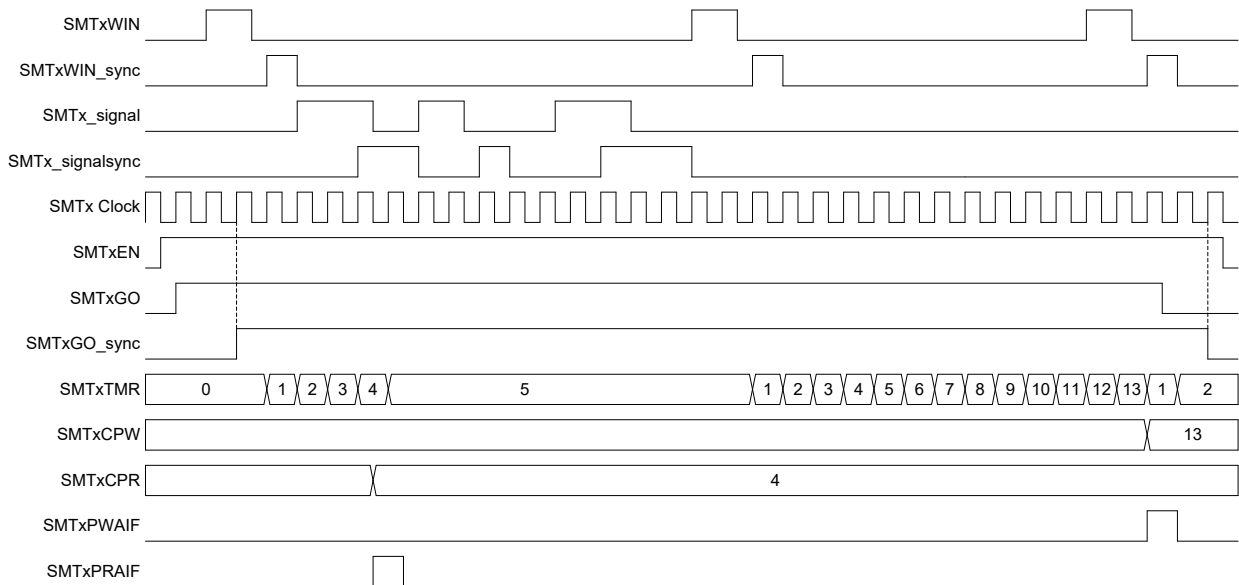


**37.1.6.7 Time of Flight Measurement Mode**

This mode measures the time interval between a rising edge on the window input and a rising edge on the signal input, beginning to increment the timer upon observing a rising edge on the window input, while updating the SMTxCPR register and resetting the timer upon observing a rising edge on the signal input. In the event of two rising edges of the window signal without a signal rising edge, it will update the SMTxCPW register with the current value of the timer and reset the timer value. See figures below.

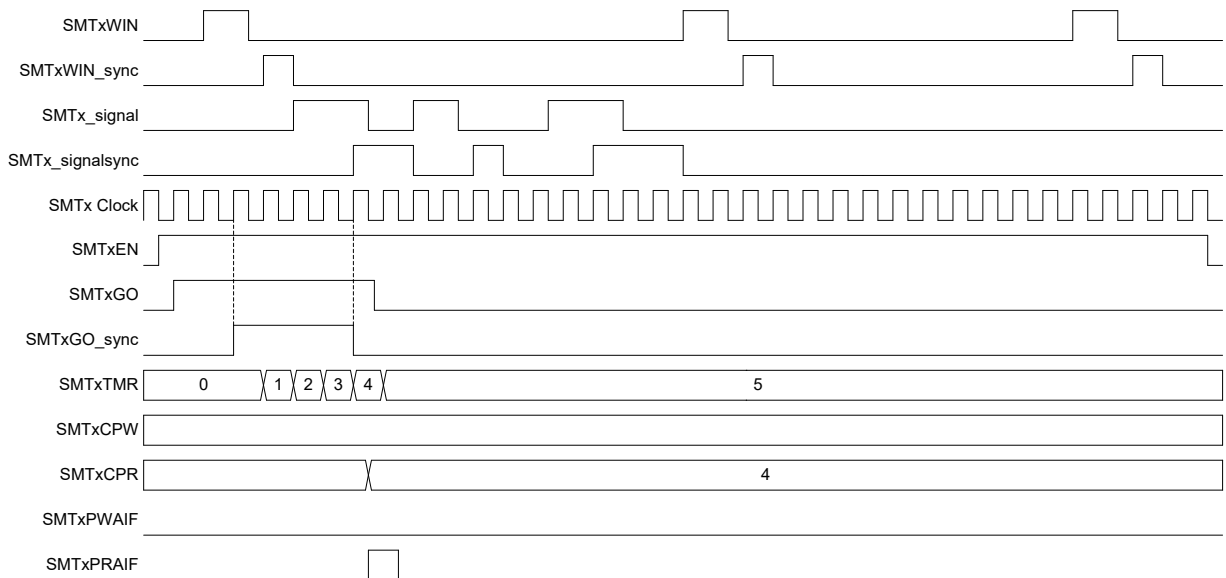
**Figure 37-13. Time of Flight Mode, Repeat Acquisition Timing Diagram**

Rev. 10-000185A  
4/20/18



**Figure 37-14. Time of Flight Mode, Single Acquisition Timing Diagram**

Rev. 10-000185A  
4/20/18

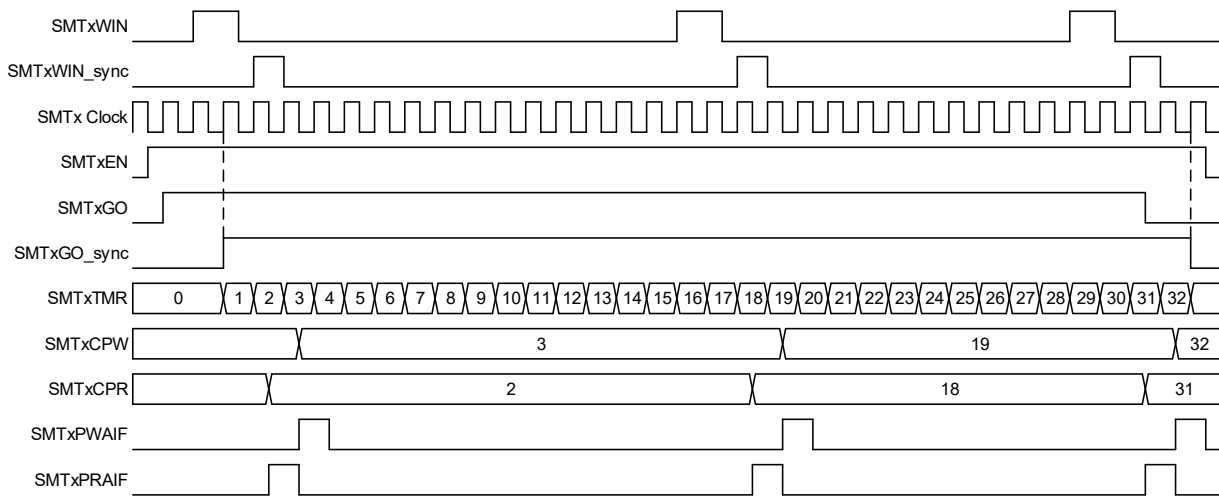


### 37.1.6.8 Capture Mode

This mode captures the timer value based on a rising or falling edge on the window input and triggers an interrupt. This mimics the capture feature of a CCP module. The timer begins incrementing upon the SMTxGO bit being set, and updates the value of the SMTxCPR register on each rising edge of window signal, and updates the value of the SMTxCPW register on each falling edge of the window signal. The timer is not reset by any hardware conditions in this mode and must be reset by software, if desired. See figures below.

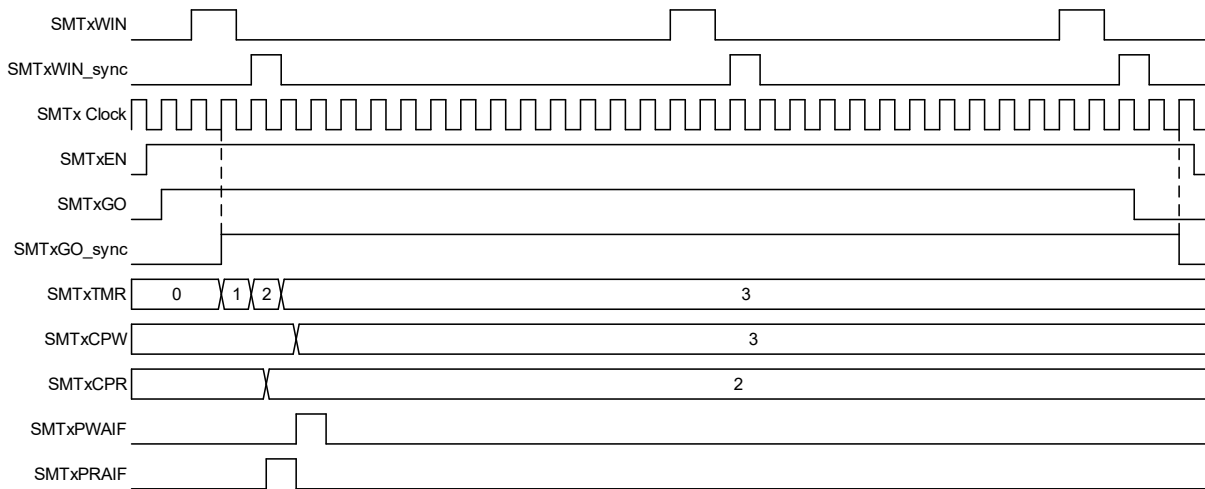
**Figure 37-15. Capture Mode, Repeat Acquisition Timing Diagram**

Rev. 10-000-188A  
12/15/2013



**Figure 37-16. Capture Mode, Single Acquisition Timing Diagram**

Rev. 10-000-187A  
12/15/2013

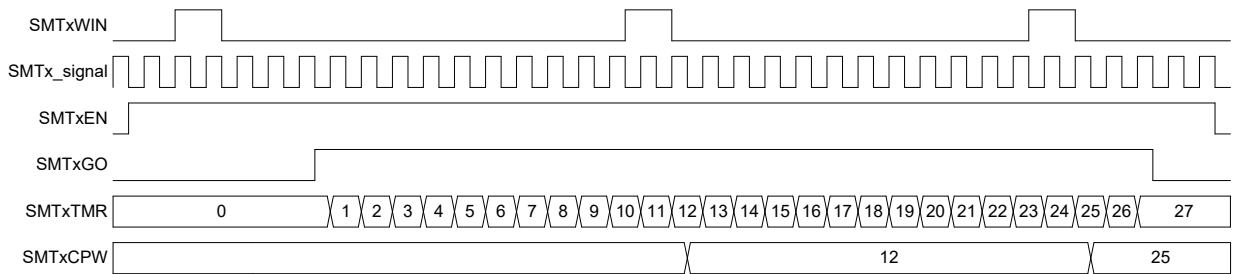


**37.1.6.9 Counter Mode**

This mode increments the timer on each pulse of the signal input. This mode is asynchronous to the SMT clock and uses the signal input as a time source. The SMTxCPW register will be updated with the current SMTxTMR value on the falling edge of the window input. See figure below.

**Figure 37-17. Counter Mode Timing Diagram**

Rev. 10-000185A  
4/12/2016

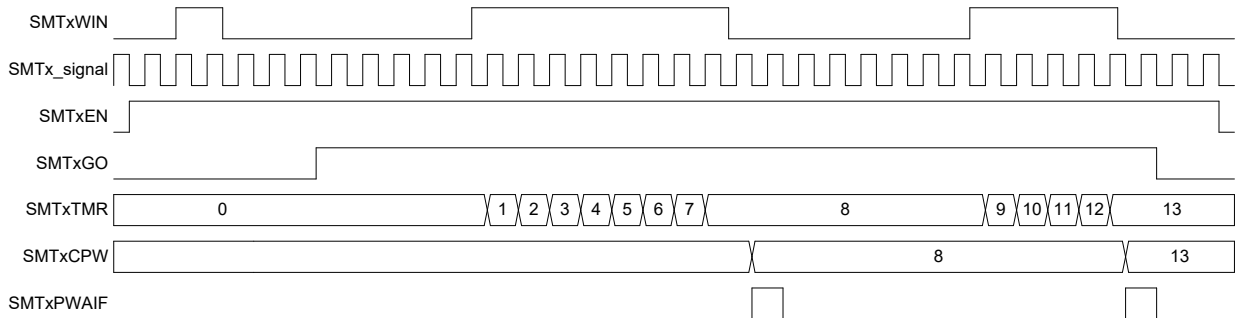


**37.1.6.10 Gated Counter Mode**

This mode counts pulses on the signal input, gated by the window input. It begins incrementing the timer upon seeing a rising edge of the window input and updates the SMTxCPW register upon a falling edge on the window input. See figures below.

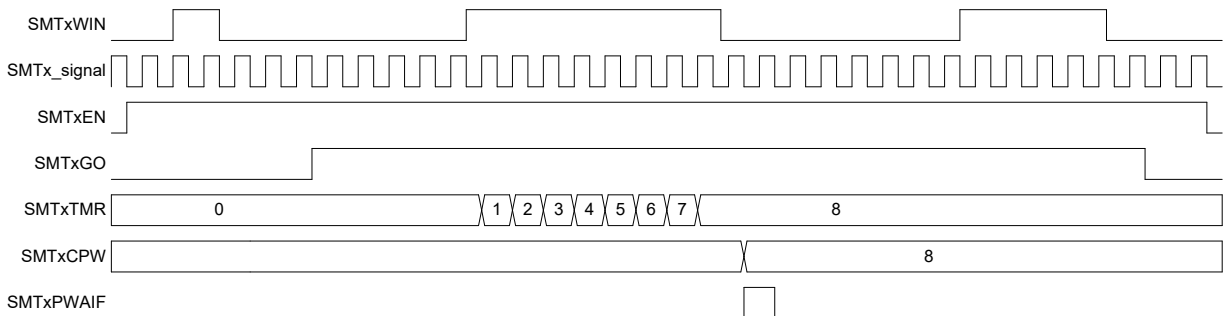
**Figure 37-18. Gated Counter Mode, Repeat Acquisition Timing Diagram**

Rev. 10-000185A  
12/18/2013



**Figure 37-19. Gated Counter Mode, Single Acquisition Timing Diagram**

Rev. 10-000181A  
12/18/2013

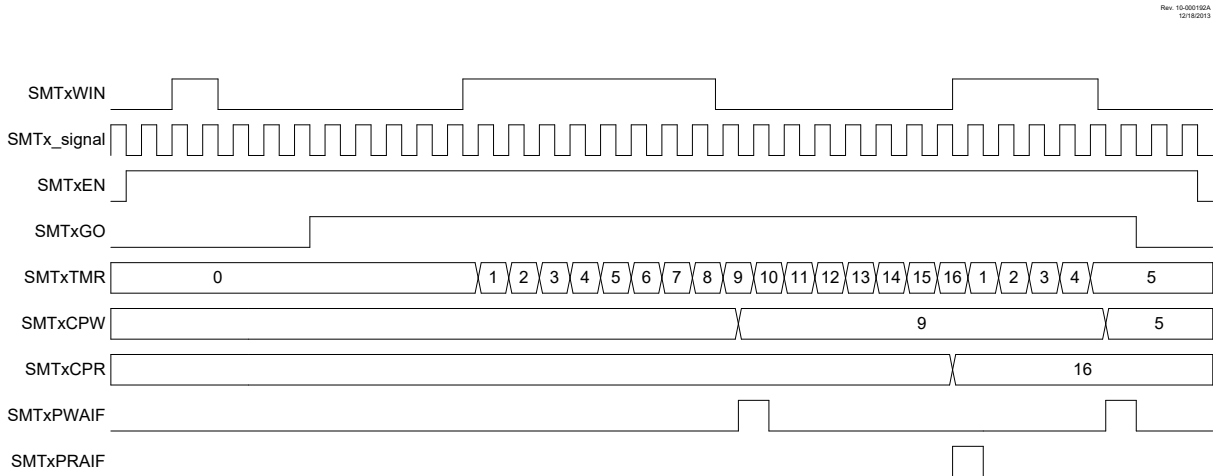


**37.1.6.11 Windowed Counter Mode**

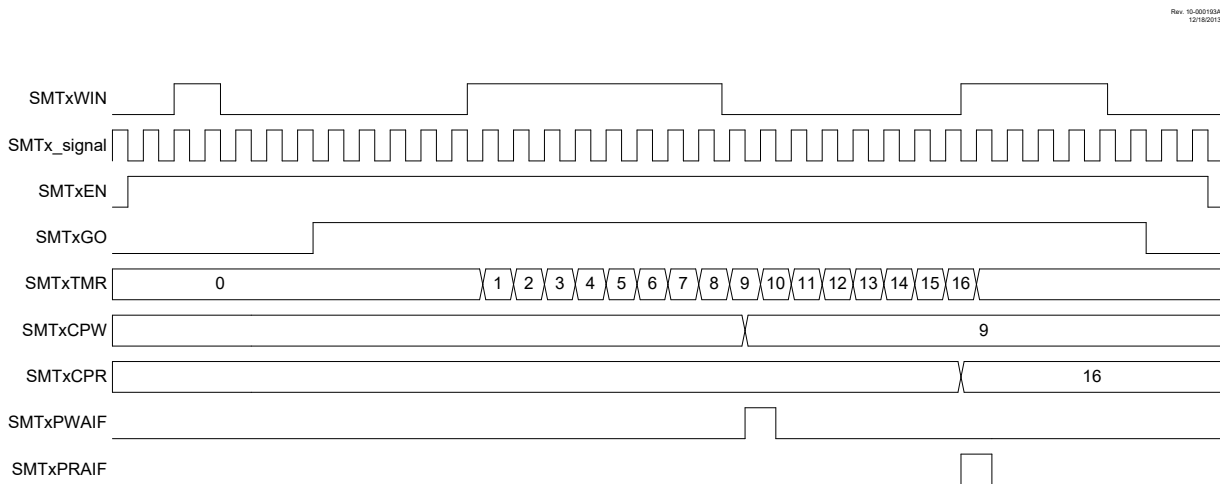
This mode counts pulses on the signal input, within a window dictated by the window input. It begins counting upon seeing a rising edge of the window input, updates the SMTxCPW register on a falling edge

of the window input, and updates the SMTxCPR register on each rising edge of the window input after the first. See figures below.

**Figure 37-20. Windowed Counter Mode, Repeat Acquisition Timing Diagram**



**Figure 37-21. Windowed Counter Mode, Single Acquisition Timing Diagram**



### 37.1.7 Interrupts

The SMT has three interrupts:

- **Pulse Width Acquisition Interrupt (SMTxPWAIF):** Interrupt triggers when SMTxCPW is updated
- **Period Acquisition Interrupt (SMTxPRAIF):** Interrupt triggers when SMTxCPR is updated
- **Counter Period Match Interrupt (SMTxIF):** Interrupt triggers when SMTxTMR equals SMTxPR

Each of the above interrupts can be enabled/disabled using the corresponding bits in the PIEx register.

### 37.1.8 Operation During Sleep

The SMT can operate during SLEEP, IDLE, and DOZE modes; provided that the clock and signal sources continue to function. System clock sources, like  $F_{OSC}$  and  $F_{OSC}/4$ , are disabled in Sleep.

### 37.2 Register Summary - SMT Control

Address	Name	Bit Pos.								
0x048C	SMT1TMR	7:0	TMRL[7:0]							
		15:8	TMRH[7:0]							
		23:16	TMRU[7:0]							
0x048F	SMT1CPR	7:0	CPRL[7:0]							
		15:8	CPRH[7:0]							
		23:16	CPRU[7:0]							
0x0492	SMT1CPW	7:0	CPWL[7:0]							
		15:8	CPWH[7:0]							
		23:16	CPWU[7:0]							
0x0495	SMT1PR	7:0	PRL[7:0]							
		15:8	PRH[7:0]							
		23:16	PRU[7:0]							
0x0498	SMT1CON0	7:0	EN		STP	WPOL	SPOL	CPOL	PS[1:0]	
0x0499	SMT1CON1	7:0	GO	REPEAT			MODE[3:0]			
0x049A	SMT1STAT	7:0	CPRUP	CPWUP		RST		TS	WS	AS
0x049B	SMT1CLK	7:0					CSEL[2:0]			
0x049C	SMT1SIG	7:0				SSEL[4:0]				
0x049D	SMT1WIN	7:0				WSEL[4:0]				
0x049E ... 0x050B	Reserved									
0x050C	SMT2TMR	7:0	TMRL[7:0]							
		15:8	TMRH[7:0]							
		23:16	TMRU[7:0]							
0x050F	SMT2CPR	7:0	CPRL[7:0]							
		15:8	CPRH[7:0]							
		23:16	CPRU[7:0]							
0x0512	SMT2CPW	7:0	CPWL[7:0]							
		15:8	CPWH[7:0]							
		23:16	CPWU[7:0]							
0x0515	SMT2PR	7:0	PRL[7:0]							
		15:8	PRH[7:0]							
		23:16	PRU[7:0]							
0x0518	SMT2CON0	7:0	EN		STP	WPOL	SPOL	CPOL	PS[1:0]	
0x0519	SMT2CON1	7:0	GO	REPEAT			MODE[3:0]			
0x051A	SMT2STAT	7:0	CPRUP	CPWUP		RST		TS	WS	AS
0x051B	SMT2CLK	7:0					CSEL[2:0]			
0x051C	SMT2SIG	7:0				SSEL[4:0]				
0x051D	SMT2WIN	7:0				WSEL[4:0]				

### 37.3 Register Definitions: SMT Control

### 37.3.1 SMTxCON0

**Name:** SMTxCON0  
**Address:** 0x498,0x518

SMT Control Register 0

Bit	7	6	5	4	3	2	1	0
	EN		STP	WPOL	SPOL	CPOL	PS[1:0]	
Access	R/W		R/W	R/W	R/W	R/W	R/W	R/W
Reset	0		0	0	0	0	0	0

#### Bit 7 – EN SMT Enable Bit

Value	Description
1	SMT is enabled
0	SMT is disabled; internal states are reset, clock requests are disabled

#### Bit 5 – STP SMT Counter Halt Enable bit

Value	Condition	Description
1	When SMTxTMR = SMTxPR	Counter remains SMTxPR; period match interrupt occurs when clocked
0	When SMTxTMR = SMTxPR	Counter resets to 0x000000; period match interrupt occurs when clocked

#### Bit 4 – WPOL SMTxWIN Input Polarity Control bit

Value	Description
1	Window signal is active-low/falling edge enabled
0	Window signal is active-high/rising edge enabled

#### Bit 3 – SPOL SMTxSIG Input Polarity Control bit

Value	Description
1	SMT Signal is active-low/falling edge enabled
0	SMT Signal is active-high/rising edge enabled

#### Bit 2 – CPOL SMT Clock Input Polarity Control bit

Value	Description
1	SMTxTMR increments on the falling edge of the selected clock signal
0	SMTxTMR increments on the rising edge of the selected clock signal

#### Bits 1:0 – PS[1:0] SMT Prescale Select bits

Value	Description
11	Prescaler = 1:8
10	Prescaler = 1:4
01	Prescaler = 1:2
00	Prescaler = 1:1

### 37.3.2 SMTxCON1

**Name:** SMTxCON1  
**Address:** 0x499,0x519

SMT Control Register 1

Bit	7	6	5	4	3	2	1	0
	GO	REPEAT			MODE[3:0]			
Access	R/W	R/W			R/W	R/W	R/W	R/W
Reset	0	0			0	0	0	0

**Bit 7 – GO** SMT GO Data Acquisition Bit

Value	Description
1	Incrementing, acquiring data is enabled
0	Incrementing, acquiring data is disabled

**Bit 6 – REPEAT** SMT Repeat Acquisition Enable Bit

Value	Description
1	Repeat Data Acquisition mode is enabled
0	Single Acquisition mode is enabled

**Bits 3:0 – MODE[3:0]** SMT Operation Mode Select bits

Value	Description
1111	Reserved
1110	Reserved
1101	Reserved
1100	Reserved
1011	Reserved
1010	Windowed counter
1001	Gated counter
1000	Counter
0111	Capture
0110	Time of flight
0101	Gated windowed measurement
0100	Windowed measurement
0011	High and low time measurement
0010	Period and Duty-Cycle Acquisition
0001	Gated Timer
0000	Timer



**37.3.3 SMTxSTAT**

**Name:** SMTxSTAT  
**Address:** 0x49A,0x51A

SMT Status Register

Bit	7	6	5	4	3	2	1	0
	CPRUP	CPWUP		RST		TS	WS	AS
Access	R/W/HC	R/W/HC		R/W		RO	RO	RO
Reset	0	0		0		0	0	0

**Bit 7 – CPRUP** SMT Manual Period Buffer Update bit

Value	Description
1	Request update to SMTxCPR registers
0	SMTxCPR registers update is complete

**Bit 6 – CPWUP** SMT Manual Pulse Width Buffer Update bit

Value	Description
1	Request update to SMTxCPW registers
0	SMTxCPW registers update is complete

**Bit 4 – RST** SMT Manual Timer Reset bit

Value	Description
1	Request Reset to SMTxTMR registers
0	SMTxTMR registers update is complete

**Bit 2 – TS** SMT GO Value Status bit

Value	Description
1	SMTxTMR is incrementing
0	SMTxTMR is not incrementing

**Bit 1 – WS** SMT Window Status bit

Value	Description
1	SMT window is open
0	SMT window is closed

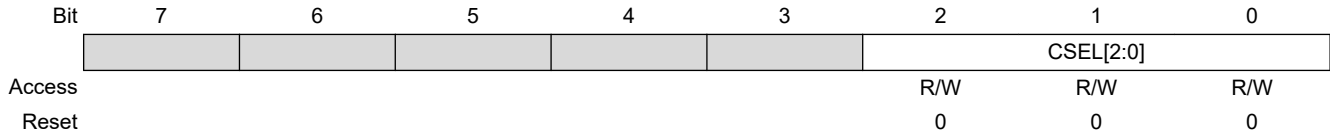
**Bit 0 – AS** SMT Signal Value Status bit

Value	Description
1	SMT acquisition is in progress
0	SMT acquisition is not in progress

**37.3.4 SMTxCLK**

**Name:** SMTxCLK  
**Address:** 0x49B,0x51B

SMT Clock Selection Register



**Bits 2:0 – CSEL[2:0]** SMT Clock Selection bits

**Table 37-5. SMT Clock Source Selection**

CSEL<2:0>	Clock Source
111	CLKREF output
110	SOSC
101	MFINTOSC (31.25kHz)
100	MFINTOSC (500kHz)
011	LFINTOSC
010	HFINTOSC
001	F <sub>Osc</sub>
000	F <sub>Osc</sub> /4

### 37.3.5 SMTxWIN

**Name:** SMTxWIN  
**Address:** 0x49D,0x51D

SMT Window Input Select Register

	7	6	5	4	3	2	1	0
					WSEL[4:0]			
Access				R/W	R/W	R/W	R/W	R/W
Reset				0	0	0	0	0

**Bits 4:0 – WSEL[4:0]** SMT Window Selection bits

**Table 37-6. SMT Window Selection**

WSEL<4:0>	SMT1 Window Source	SMT2 Window Source
11111-11001	Reserved	Reserved
11000	CCP5OUT	CCP5OUT
10111	NCO1OUT	NCO1OUT
10110	SMT2_overflow	SMT1_overflow
10101	CLKREFOUT	CLKREFOUT
10100	CLC4OUT	CLC4OUT
10011	CLC3OUT	CLC3OUT
10010	CLC2OUT	CLC2OUT
10001	CLC1OUT	CLC1OUT
10000	ZCDOUT	ZCDOUT
01111	C2OUT	C2OUT
01110	C1OUT	C1OUT
01101	PWM7OUT	PWM7OUT
01100	PWM6OUT	PWM6OUT
01011	CCP4OUT	CCP4OUT
01010	CCP3OUT	CCP3OUT
01001	CCP2OUT	CCP2OUT
01000	CCP1OUT	CCP1OUT
00111	TMR6_postscaled_out	TMR6_postscaled_out
00110	TMR4_postscaled_out	TMR4_postscaled_out
00101	TMR2_postscaled_out	TMR2_postscaled_out
00100	TMR0_overflow	TMR0_overflow

# PIC16(L)F18455/56

## (SMT) Signal Measurement Timer

WSEL<4:0>	SMT1 Window Source	SMT2 Window Source
00011	SOSC	SOSC
00010	MFINTOSC (31.25kHz)	MFINTOSC (31.25kHz)
00001	LFINTOSC (31.25kHz)	LFINTOSC (31.25kHz)
00000	Pin Selected by SMT1WINPPS	Pin Selected by SMT1WINPPS

**37.3.6 SMTxSIG**

**Name:** SMTxSIG  
**Address:** 0x49C,0x51C

SMT Signal Selection bits

	7	6	5	4	3	2	1	0
	SSEL[4:0]							
Access				R/W	R/W	R/W	R/W	R/W
Reset				0	0	0	0	0

**Bits 4:0 – SSEL[4:0]** SMT Signal Selection bits

**Table 37-7. SMT Signal Selection**

SSEL<4:0>	SMT1 Signal Source	SMT2 Signal Source
11111-11000	Reserved	Reserved
10111	SMT2 overflow	SMT1 overflow
10110	CCP5OUT	CCP5OUT
10101	CLC4OUT	CLC4OUT
10100	CLC3OUT	CLC3OUT
10011	CLC2OUT	CLC2OUT
10010	CLC1OUT	CLC1OUT
10001	ZCDOUT	ZCDOUT
10000	C2OUT	C2OUT
01111	C1OUT	C1OUT
01110	NCO1OUT	NCO1OUT
01101	PWM7OUT	PWM7OUT
01100	PWM6OUT	PWM6OUT
01011	CCP4OUT	CCP4OUT
01010	CCP3OUT	CCP3OUT
01001	CCP2OUT	CCP2OUT
01000	CCP1OUT	CCP1OUT
00111	TMR6 postscaled output	TMR6 postscaled output
00110	TMR5 overflow	TMR5 overflow
00101	TMR4 postscaled output	TMR4 postscaled output
00100	TMR3 overflow	TMR3 overflow
00011	TMR2 postscaled output	TMR2 postscaled output

# PIC16(L)F18455/56

## (SMT) Signal Measurement Timer

SSEL<4:0>	SMT1 Signal Source	SMT2 Signal Source
00010	TMR1 overflow	TMR1 overflow
00001	TMR0 overflow	TMR0 overflow
00000	Pin Selected by SMT1SIGPPS	Pin Selected by SMT2SIGPPS

**37.3.7 SMTxTMR**

**Name:** SMTxTMR  
**Address:** 0x48C,0x50C

SMT Timer Register

Bit	23	22	21	20	19	18	17	16
TMRU[7:0]								
Access	R/W	R/W	R/W	R/W	R/W	R/W	R/W	R/W
Reset	0	0	0	0	0	0	0	0
Bit	15	14	13	12	11	10	9	8
TMRH[7:0]								
Access	R/W	R/W	R/W	R/W	R/W	R/W	R/W	R/W
Reset	0	0	0	0	0	0	0	0
Bit	7	6	5	4	3	2	1	0
TMRL[7:0]								
Access	R/W	R/W	R/W	R/W	R/W	R/W	R/W	R/W
Reset	0	0	0	0	0	0	0	0

**Bits 23:16 – TMRU[7:0]** Upper byte of the SMT timer register

**Bits 15:8 – TMRH[7:0]** High byte of the SMT timer register

**Bits 7:0 – TMRL[7:0]** Lower byte of the SMT timer register

**37.3.8 SMTxCPR**

**Name:** SMTxCPR  
**Address:** 0x48F,0x50F

SMT Captured Period Register

Bit	23	22	21	20	19	18	17	16
	CPRU[7:0]							
Access	RO	RO	RO	RO	RO	RO	RO	RO
Reset	x	x	x	x	x	x	x	x
Bit	15	14	13	12	11	10	9	8
	CPRH[7:0]							
Access	RO	RO	RO	RO	RO	RO	RO	RO
Reset	x	x	x	x	x	x	x	x
Bit	7	6	5	4	3	2	1	0
	CPRL[7:0]							
Access	RO	RO	RO	RO	RO	RO	RO	RO
Reset	x	x	x	x	x	x	x	x

**Bits 23:16 – CPRU[7:0]** Upper byte of SMT capture period register

Reset States: POR/BOR = xxxxxxxx  
All Other Resets = uuuuuuuu

**Bits 15:8 – CPRH[7:0]** High byte of SMT capture period register

Reset States: POR/BOR = xxxxxxxx  
All Other Resets = uuuuuuuu

**Bits 7:0 – CPRL[7:0]** Lower byte of SMT capture period register

Reset States: POR/BOR = xxxxxxxx  
All Other Resets = uuuuuuuu



**37.3.9 SMTxCPW**

**Name:** SMTxCPW  
**Address:** 0x492,0x512

SMT Captured Pulse Width Register

Bit	23	22	21	20	19	18	17	16
	CPWU[7:0]							
Access	RO	RO	RO	RO	RO	RO	RO	RO
Reset	x	x	x	x	x	x	x	x
Bit	15	14	13	12	11	10	9	8
	CPWH[7:0]							
Access	RO	RO	RO	RO	RO	RO	RO	RO
Reset	x	x	x	x	x	x	x	x
Bit	7	6	5	4	3	2	1	0
	CPWL[7:0]							
Access	RO	RO	RO	RO	RO	RO	RO	RO
Reset	x	x	x	x	x	x	x	x

**Bits 23:16 – CPWU[7:0]** Upper Byte of the captured pulse width register

Reset States: POR/BOR = xxxxxxxx  
All Other Resets = uuuuuuuu

**Bits 15:8 – CPWH[7:0]** High Byte of the captured pulse width register

Reset States: POR/BOR = xxxxxxxx  
All Other Resets = uuuuuuuu

**Bits 7:0 – CPWL[7:0]** Lower Byte of the captured pulse width register

Reset States: POR/BOR = xxxxxxxx  
All Other Resets = uuuuuuuu

**37.3.10 SMTxPR**

**Name:** SMTxPR  
**Address:** 0x495,0x515

SMT Period Register

Bit	23	22	21	20	19	18	17	16
PRU[7:0]								
Access	R/W	R/W	R/W	R/W	R/W	R/W	R/W	R/W
Reset	1	1	1	1	1	1	1	1
Bit	15	14	13	12	11	10	9	8
PRH[7:0]								
Access	R/W	R/W	R/W	R/W	R/W	R/W	R/W	R/W
Reset	1	1	1	1	1	1	1	1
Bit	7	6	5	4	3	2	1	0
PRL[7:0]								
Access	R/W	R/W	R/W	R/W	R/W	R/W	R/W	R/W
Reset	1	1	1	1	1	1	1	1

**Bits 23:16 – PRU[7:0]** Upper byte of the SMT period register

**Bits 15:8 – PRH[7:0]** High byte of the SMT period register

**Bits 7:0 – PRL[7:0]** Lower byte of the SMT period register

### 38. Register Summary

Address	Name	Bit Pos.								
0x00	INDF0	7:0	INDF0[7:0]							
0x01	INDF1	7:0	INDF1[7:0]							
0x02	PCL	7:0	PCL[7:0]							
0x03	STATUS	7:0				T $\bar{O}$	P $\bar{D}$	Z	DC	C
0x04	FSR0	7:0	FSRL[7:0]							
		15:8	FSRH[7:0]							
0x06	FSR1	7:0	FSRL[7:0]							
		15:8	FSRH[7:0]							
0x08	BSR	7:0	BSR[5:0]							
0x09	WREG	7:0	WREG[7:0]							
0x0A	PCLATH	7:0	PCLATH[6:0]							
0x0B	INTCON	7:0	GIE	PEIE						INTEDG
0x0C	PORTA	7:0	RA7	RA6	RA5	RA4	RA3	RA2	RA1	RA0
0x0D	PORTB	7:0	RB7	RB6	RB5	RB4	RB3	RB2	RB1	RB0
0x0E	PORTC	7:0	RC7	RC6	RC5	RC4	RC3	RC2	RC1	RC0
0x0F	Reserved									
0x10	PORTE	7:0					RE3			
0x11	Reserved									
0x12	TRISA	7:0	TRISA7	TRISA6	TRISA5	TRISA4	TRISA3	TRISA2	TRISA1	TRISA0
0x13	TRISB	7:0	TRISB7	TRISB6	TRISB5	TRISB4	TRISB3	TRISB2	TRISB1	TRISB0
0x14	TRISC	7:0	TRISC7	TRISC6	TRISC5	TRISC4	TRISC3	TRISC2	TRISC1	TRISC0
0x15	Reserved									
...										
0x17										
0x18	LATA	7:0	LATA7	LATA6	LATA5	LATA4	LATA3	LATA2	LATA1	LATA0
0x19	LATB	7:0	LATB7	LATB6	LATB5	LATB4	LATB3	LATB2	LATB1	LATB0
0x1A	LATC	7:0	LATC7	LATC6	LATC5	LATC4	LATC3	LATC2	LATC1	LATC0
0x1B	Reserved									
...										
0x7F										
0x80	INDF0	7:0	INDF0[7:0]							
0x81	INDF1	7:0	INDF1[7:0]							
0x82	PCL	7:0	PCL[7:0]							
0x83	STATUS	7:0				T $\bar{O}$	P $\bar{D}$	Z	DC	C
0x84	FSR0	7:0	FSRL[7:0]							
		15:8	FSRH[7:0]							
0x86	FSR1	7:0	FSRL[7:0]							
		15:8	FSRH[7:0]							
0x88	BSR	7:0	BSR[5:0]							
0x89	WREG	7:0	WREG[7:0]							
0x8A	PCLATH	7:0	PCLATH[6:0]							
0x8B	INTCON	7:0	GIE	PEIE						INTEDG
0x8C	ADLTH	7:0	LTHL[7:0]							

# PIC16(L)F18455/56

## Register Summary

Address	Name	Bit Pos.																				
0x8E	ADUTH	15:8	LTHH[7:0]																			
		7:0	UTHL[7:0]																			
		15:8	UTHH[7:0]																			
0x90	ADERR	7:0	ADERRL[7:0]																			
		15:8	ERRH[7:0]																			
0x92	ADSTPT	7:0	STPTL[7:0]																			
		15:8	STPTH[7:0]																			
0x94	ADFLTR	7:0	FLTRL[7:0]																			
		15:8	FLTRH[7:0]																			
0x96	ADACC	7:0	ACCL[7:0]																			
		15:8	ACCH[7:0]																			
		23:16	ACCU[1:0]																			
0x99	ADCNT	7:0	CNT[7:0]																			
0x9A	ADRPT	7:0	RPT[7:0]																			
0x9B	ADPREV	7:0	PREVL[7:0]																			
		15:8	PREVH[7:0]																			
0x9D	ADRES	7:0	RESL[7:0]																			
		15:8	RESH[7:0]																			
0x9F	ADPCH	7:0	PCH[5:0]																			
0xA0 ... 0xFF	Reserved																					
0x0100	INDF0	7:0	INDF0[7:0]																			
0x0101	INDF1	7:0	INDF1[7:0]																			
0x0102	PCL	7:0	PCL[7:0]																			
0x0103	STATUS	7:0					TO		PD			Z		DC						C		
0x0104	FSR0	7:0	FSRL[7:0]																			
		15:8	FSRH[7:0]																			
0x0106	FSR1	7:0	FSRL[7:0]																			
		15:8	FSRH[7:0]																			
0x0108	BSR	7:0	BSR[5:0]																			
0x0109	WREG	7:0	WREG[7:0]																			
0x010A	PCLATH	7:0	PCLATH[6:0]																			
0x010B	INTCON	7:0	GIE		PEIE																INTEDG	
0x010C	ADACQ	7:0	ACQL[7:0]																			
		15:8	ACQH[4:0]																			
0x010E	ADCAP	7:0	CAP[4:0]																			
0x010F	ADPRE	7:0	PREL[7:0]																			
		15:8	PREH[4:0]																			
0x0111	ADCON0	7:0	ON		CONT			CS				FRM									GO	
0x0112	ADCON1	7:0	PPOL		IPEN		GPOL															DSEN
0x0113	ADCON2	7:0	PSIS			CRS[2:0]				ACLR												MD[2:0]
0x0114	ADCON3	7:0				CALC[2:0]				SOI												TMD[2:0]
0x0115	ADSTAT	7:0	OV		UTHR		LTHR		MATH													STAT[2:0]
0x0116	ADREF	7:0							NREF													PREF[1:0]
0x0117	ADACT	7:0																				ACT[4:0]

# PIC16(L)F18455/56

## Register Summary

Address	Name	Bit Pos.									
0x0118	ADCLK	7:0									CS[5:0]
0x0119	RC1REG	7:0									RCREG[7:0]
0x011A	TX1REG	7:0									TXREG[7:0]
0x011B	SP1BRG	7:0									SPBRGL[7:0]
		15:8									SPBRGH[7:0]
0x011D	RC1STA	7:0	SPEN	RX9	SREN	CREN	ADDEN	FERR	OERR		RX9D
0x011E	TX1STA	7:0	CSRC	TX9	TXEN	SYNC	SENDB	BRGH	TRMT		TX9D
0x011F	BAUD1CON	7:0	ABDOVF	RCIDL		SCKP	BRG16			WUE	ABDEN
0x0120	Reserved										
...											
0x017F											
0x0180	INDF0	7:0									INDF0[7:0]
0x0181	INDF1	7:0									INDF1[7:0]
0x0182	PCL	7:0									PCL[7:0]
0x0183	STATUS	7:0				TO	PD	Z	DC		C
0x0184	FSR0	7:0									FSRL[7:0]
		15:8									FSRH[7:0]
0x0186	FSR1	7:0									FSRL[7:0]
		15:8									FSRH[7:0]
0x0188	BSR	7:0									BSR[5:0]
0x0189	WREG	7:0									WREG[7:0]
0x018A	PCLATH	7:0									PCLATH[6:0]
0x018B	INTCON	7:0	GIE	PEIE							INTEDG
0x018C	SSP1BUF	7:0									BUF[7:0]
0x018D	SSP1ADD	7:0									ADD[7:0]
0x018E	SSP1MSK	7:0									MSK[6:0] MSK0
0x018F	SSP1STAT	7:0	SMP	CKE	D/A	P	S	R/W	UA		BF
0x0190	SSP1CON1	7:0	WCOL	SSPOV	SSPEN	CKP					SSPM[3:0]
0x0191	SSP1CON2	7:0	GCEN	ACKSTAT	ACKDT	ACKEN	RCEN	PEN	RSEN		SEN
0x0192	SSP1CON3	7:0	ACKTIM	PCIE	SCIE	BOEN	SDAHT	SBCDE	AHEN		DHEN
0x0193	Reserved										
...											
0x0195											
0x0196	SSP2BUF	7:0									BUF[7:0]
0x0197	SSP2ADD	7:0									ADD[7:0]
0x0198	SSP2MSK	7:0									MSK[6:0] MSK0
0x0199	SSP2STAT	7:0	SMP	CKE	D/A	P	S	R/W	UA		BF
0x019A	SSP2CON1	7:0	WCOL	SSPOV	SSPEN	CKP					SSPM[3:0]
0x019B	SSP2CON2	7:0	GCEN	ACKSTAT	ACKDT	ACKEN	RCEN	PEN	RSEN		SEN
0x019C	SSP2CON3	7:0	ACKTIM	PCIE	SCIE	BOEN	SDAHT	SBCDE	AHEN		DHEN
0x019D	Reserved										
...											
0x01FF											
0x0200	INDF0	7:0									INDF0[7:0]
0x0201	INDF1	7:0									INDF1[7:0]
0x0202	PCL	7:0									PCL[7:0]

# PIC16(L)F18455/56

## Register Summary

Address	Name	Bit Pos.								
0x0203	STATUS	7:0				T $\bar{O}$	P $\bar{D}$	Z	DC	C
0x0204	FSR0	7:0	FSRL[7:0]							
		15:8	FSRH[7:0]							
0x0206	FSR1	7:0	FSRL[7:0]							
		15:8	FSRH[7:0]							
0x0208	BSR	7:0	BSR[5:0]							
0x0209	WREG	7:0	WREG[7:0]							
0x020A	PCLATH	7:0	PCLATH[6:0]							
0x020B	INTCON	7:0	GIE	PEIE						INTEDG
0x020C	TMR1	7:0	TMRxL[7:0]							
		15:8	TMRxH[7:0]							
0x020E	T1CON	7:0			CKPS[1:0]		SYNC	RD16	ON	
0x020F	T1GCON	7:0	GE	GPOL	GTM	GSPM	GGO/DONE	GVAL		
0x0210	TMR1GATE	7:0	GSS[4:0]							
0x0211	TMR1CLK	7:0	CS[4:0]							
0x0212	TMR3	7:0	TMRxL[7:0]							
		15:8	TMRxH[7:0]							
0x0214	T3CON	7:0			CKPS[1:0]		SYNC	RD16	ON	
0x0215	T3GCON	7:0	GE	GPOL	GTM	GSPM	GGO/DONE	GVAL		
0x0216	TMR3GATE	7:0	GSS[4:0]							
0x0217	TMR3CLK	7:0	CS[4:0]							
0x0218	TMR5	7:0	TMRxL[7:0]							
		15:8	TMRxH[7:0]							
0x021A	T5CON	7:0			CKPS[1:0]		SYNC	RD16	ON	
0x021B	T5GCON	7:0	GE	GPOL	GTM	GSPM	GGO/DONE	GVAL		
0x021C	TMR5GATE	7:0	GSS[4:0]							
0x021D	TMR5CLK	7:0	CS[4:0]							
0x021E	CCPTMRS0	7:0	C4TSEL[1:0]		C3TSEL[1:0]		C2TSEL[1:0]		C1TSEL[1:0]	
0x021F	CCPTMRS1	7:0			P7TSEL[1:0]		P6TSEL[1:0]			
0x0220 ... 0x027F	Reserved									
0x0280	INDF0	7:0	INDF0[7:0]							
0x0281	INDF1	7:0	INDF1[7:0]							
0x0282	PCL	7:0	PCL[7:0]							
0x0283	STATUS	7:0				T $\bar{O}$	P $\bar{D}$	Z	DC	C
0x0284	FSR0	7:0	FSRL[7:0]							
		15:8	FSRH[7:0]							
0x0286	FSR1	7:0	FSRL[7:0]							
		15:8	FSRH[7:0]							
0x0288	BSR	7:0	BSR[5:0]							
0x0289	WREG	7:0	WREG[7:0]							
0x028A	PCLATH	7:0	PCLATH[6:0]							
0x028B	INTCON	7:0	GIE	PEIE						INTEDG
0x028C	T2TMR	7:0	TxTMR[7:0]							
0x028D	T2PR	7:0	TxPR[7:0]							

# PIC16(L)F18455/56

## Register Summary

Address	Name	Bit Pos.									
0x028E	T2CON	7:0	ON	CKPS[2:0]			OUTPS[3:0]				
0x028F	T2HLT	7:0	PSYNC	CPOL	CSYNC	MODE[4:0]					
0x0290	T2CLKCON	7:0				CS[3:0]					
0x0291	T2RST	7:0				RSEL[3:0]					
0x0292	T4TMR	7:0				TxTMR[7:0]					
0x0293	T4PR	7:0				TxPR[7:0]					
0x0294	T4CON	7:0	ON	CKPS[2:0]			OUTPS[3:0]				
0x0295	T4HLT	7:0	PSYNC	CPOL	CSYNC	MODE[4:0]					
0x0296	T4CLKCON	7:0				CS[3:0]					
0x0297	T4RST	7:0				RSEL[3:0]					
0x0298	T6TMR	7:0				TxTMR[7:0]					
0x0299	T6PR	7:0				TxPR[7:0]					
0x029A	T6CON	7:0	ON	CKPS[2:0]			OUTPS[3:0]				
0x029B	T6HLT	7:0	PSYNC	CPOL	CSYNC	MODE[4:0]					
0x029C	T6CLKCON	7:0				CS[3:0]					
0x029D	T6RST	7:0				RSEL[3:0]					
0x029E	Reserved										
0x029F	ADCPCON0	7:0	CPON								CPRDY
0x02A0 ... 0x02FF	Reserved										
0x0300	INDF0	7:0				INDF0[7:0]					
0x0301	INDF1	7:0				INDF1[7:0]					
0x0302	PCL	7:0				PCL[7:0]					
0x0303	STATUS	7:0				TO	PD	Z	DC	C	
0x0304	FSR0	7:0				FSRL[7:0]					
		15:8				FSRH[7:0]					
0x0306	FSR1	7:0				FSRL[7:0]					
		15:8				FSRH[7:0]					
0x0308	BSR	7:0				BSR[5:0]					
0x0309	WREG	7:0				WREG[7:0]					
0x030A	PCLATH	7:0				PCLATH[6:0]					
0x030B	INTCON	7:0	GIE	PEIE							INTEDG
0x030C	CCPR1	7:0				CCPRL[7:0]					
		15:8				CCPRH[7:0]					
0x030E	CCP1CON	7:0	EN		OUT	FMT	MODE[3:0]				
0x030F	CCP1CAP	7:0					CTS[2:0]				
0x0310	CCPR2	7:0				CCPRL[7:0]					
		15:8				CCPRH[7:0]					
0x0312	CCP2CON	7:0	EN		OUT	FMT	MODE[3:0]				
0x0313	CCP2CAP	7:0					CTS[2:0]				
0x0314	CCPR3	7:0				CCPRL[7:0]					
		15:8				CCPRH[7:0]					
0x0316	CCP3CON	7:0	EN		OUT	FMT	MODE[3:0]				
0x0317	CCP3CAP	7:0					CTS[2:0]				
0x0318	CCPR4	7:0				CCPRL[7:0]					

# PIC16(L)F18455/56

## Register Summary

Address	Name	Bit Pos.								
		15:8	CCPRH[7:0]							
0x031A	CCP4CON	7:0	EN		OUT	FMT	MODE[3:0]			
0x031B	CCP4CAP	7:0					CTS[2:0]			
0x031C	CCPR5	7:0	CCPRL[7:0]							
		15:8	CCPRH[7:0]							
0x031E	CCP5CON	7:0	EN		OUT	FMT	MODE[3:0]			
0x031F	CCP5CAP	7:0					CTS[2:0]			
0x0320 ... 0x037F	Reserved									
0x0380	INDF0	7:0	INDF0[7:0]							
0x0381	INDF1	7:0	INDF1[7:0]							
0x0382	PCL	7:0	PCL[7:0]							
0x0383	STATUS	7:0				T $\bar{O}$	P $\bar{D}$	Z	DC	C
0x0384	FSR0	7:0	FSRL[7:0]							
		15:8	FSRH[7:0]							
0x0386	FSR1	7:0	FSRL[7:0]							
		15:8	FSRH[7:0]							
0x0388	BSR	7:0			BSR[5:0]					
0x0389	WREG	7:0	WREG[7:0]							
0x038A	PCLATH	7:0		PCLATH[6:0]						
0x038B	INTCON	7:0	GIE	PEIE						INTEDG
0x038C	PWM6DC	7:0	DCL[1:0]							
		15:8	DCH[7:0]							
0x038E	PWM6CON	7:0	EN		OUT	POL				
0x038F	Reserved									
0x0390	PWM7DC	7:0	DCL[1:0]							
		15:8	DCH[7:0]							
0x0392	PWM7CON	7:0	EN		OUT	POL				
0x0393 ... 0x03FF	Reserved									
0x0400	INDF0	7:0	INDF0[7:0]							
0x0401	INDF1	7:0	INDF1[7:0]							
0x0402	PCL	7:0	PCL[7:0]							
0x0403	STATUS	7:0				T $\bar{O}$	P $\bar{D}$	Z	DC	C
0x0404	FSR0	7:0	FSRL[7:0]							
		15:8	FSRH[7:0]							
0x0406	FSR1	7:0	FSRL[7:0]							
		15:8	FSRH[7:0]							
0x0408	BSR	7:0			BSR[5:0]					
0x0409	WREG	7:0	WREG[7:0]							
0x040A	PCLATH	7:0		PCLATH[6:0]						
0x040B	INTCON	7:0	GIE	PEIE						INTEDG
0x040C ...	Reserved									



# PIC16(L)F18455/56

## Register Summary

Address	Name	Bit Pos.										
0x047F												
0x0480	INDF0	7:0										INDF0[7:0]
0x0481	INDF1	7:0										INDF1[7:0]
0x0482	PCL	7:0										PCL[7:0]
0x0483	STATUS	7:0					TO	PD	Z	DC		C
0x0484	FSR0	7:0										FSRL[7:0]
		15:8										FSRH[7:0]
0x0486	FSR1	7:0										FSRL[7:0]
		15:8										FSRH[7:0]
0x0488	BSR	7:0										BSR[5:0]
0x0489	WREG	7:0										WREG[7:0]
0x048A	PCLATH	7:0										PCLATH[6:0]
0x048B	INTCON	7:0	GIE	PEIE								INTEDG
0x048C	SMT1TMR	7:0										TMRL[7:0]
		15:8										TMRH[7:0]
		23:16										TMRU[7:0]
0x048F	SMT1CPR	7:0										CPRL[7:0]
		15:8										CPRH[7:0]
		23:16										CPRU[7:0]
0x0492	SMT1CPW	7:0										CPWL[7:0]
		15:8										CPWH[7:0]
		23:16										CPWU[7:0]
0x0495	SMT1PR	7:0										PRL[7:0]
		15:8										PRH[7:0]
		23:16										PRU[7:0]
0x0498	SMT1CON0	7:0	EN		STP	WPOL	SPOL	CPOL			PS[1:0]	
0x0499	SMT1CON1	7:0	GO	REPEAT							MODE[3:0]	
0x049A	SMT1STAT	7:0	CPRUP	CPWUP		RST		TS	WS		AS	
0x049B	SMT1CLK	7:0										CSEL[2:0]
0x049C	SMT1SIG	7:0										SSEL[4:0]
0x049D	SMT1WIN	7:0										WSEL[4:0]
0x049E	Reserved											
...												
0x04FF												
0x0500	INDF0	7:0										INDF0[7:0]
0x0501	INDF1	7:0										INDF1[7:0]
0x0502	PCL	7:0										PCL[7:0]
0x0503	STATUS	7:0					TO	PD	Z	DC		C
0x0504	FSR0	7:0										FSRL[7:0]
		15:8										FSRH[7:0]
0x0506	FSR1	7:0										FSRL[7:0]
		15:8										FSRH[7:0]
0x0508	BSR	7:0										BSR[5:0]
0x0509	WREG	7:0										WREG[7:0]
0x050A	PCLATH	7:0										PCLATH[6:0]
0x050B	INTCON	7:0	GIE	PEIE								INTEDG

# PIC16(L)F18455/56

## Register Summary

Address	Name	Bit Pos.									
0x050C	SMT2TMR	7:0	TMRL[7:0]								
		15:8	TMRH[7:0]								
		23:16	TMRU[7:0]								
0x050F	SMT2CPR	7:0	CPRL[7:0]								
		15:8	CPRH[7:0]								
		23:16	CPRU[7:0]								
0x0512	SMT2CPW	7:0	CPWL[7:0]								
		15:8	CPWH[7:0]								
		23:16	CPWU[7:0]								
0x0515	SMT2PR	7:0	PRL[7:0]								
		15:8	PRH[7:0]								
		23:16	PRU[7:0]								
0x0518	SMT2CON0	7:0	EN		STP	WPOL	SPOL	CPOL	PS[1:0]		
0x0519	SMT2CON1	7:0	GO	REPEAT			MODE[3:0]				
0x051A	SMT2STAT	7:0	CPRUP	CPWUP		RST		TS	WS	AS	
0x051B	SMT2CLK	7:0						CSEL[2:0]			
0x051C	SMT2SIG	7:0					SSEL[4:0]				
0x051D	SMT2WIN	7:0					WSEL[4:0]				
0x051E ... 0x057F	Reserved										
0x0580	INDF0	7:0	INDF0[7:0]								
0x0581	INDF1	7:0	INDF1[7:0]								
0x0582	PCL	7:0	PCL[7:0]								
0x0583	STATUS	7:0				TO	PD	Z	DC	C	
0x0584	FSR0	7:0	FSRL[7:0]								
		15:8	FSRH[7:0]								
0x0586	FSR1	7:0	FSRL[7:0]								
		15:8	FSRH[7:0]								
0x0588	BSR	7:0	BSR[5:0]								
0x0589	WREG	7:0	WREG[7:0]								
0x058A	PCLATH	7:0	PCLATH[6:0]								
0x058B	INTCON	7:0	GIE	PEIE						INTEDG	
0x058C	NCO1ACC	7:0	ACCL[7:0]								
		15:8	ACCH[7:0]								
		23:16	ACCU[3:0]								
0x058F	NCO1INC	7:0	INCL[7:0]								
		15:8	INCH[7:0]								
		23:16	INCU[3:0]								
0x0592	NCO1CON	7:0	EN		OUT	POL				PFM	
0x0593	NCO1CLK	7:0	PWS[2:0]				CKS[3:0]				
0x0594 ... 0x059B	Reserved										
0x059C	TMR0L	7:0	TMR0L[7:0]								
0x059D	TMR0H	7:0	TMR0H[7:0]								

# PIC16(L)F18455/56

## Register Summary

Address	Name	Bit Pos.								
0x059E	T0CON0	7:0	T0EN		T0OUT	T016BIT	T0OUTPS[3:0]			
0x059F	T0CON1	7:0	T0CS[2:0]			T0ASYNC	T0CKPS[3:0]			
0x05A0 ... 0x05FF	Reserved									
0x0600	INDF0	7:0	INDF0[7:0]							
0x0601	INDF1	7:0	INDF1[7:0]							
0x0602	PCL	7:0	PCL[7:0]							
0x0603	STATUS	7:0			TO	PD	Z	DC	C	
0x0604	FSR0	7:0	FSRL[7:0]							
		15:8	FSRH[7:0]							
0x0606	FSR1	7:0	FSRL[7:0]							
		15:8	FSRH[7:0]							
0x0608	BSR	7:0	BSR[5:0]							
0x0609	WREG	7:0	WREG[7:0]							
0x060A	PCLATH	7:0	PCLATH[6:0]							
0x060B	INTCON	7:0	GIE	PEIE						INTEDG
0x060C	CWG1CLK	7:0								CS
0x060D	CWG1ISM	7:0	ISM[3:0]							
0x060E	CWG1DBR	7:0	DBR[5:0]							
0x060F	CWG1DBF	7:0	DBF[5:0]							
0x0610	CWG1CON0	7:0	EN	LD			MODE[2:0]			
0x0611	CWG1CON1	7:0			IN		POLD	POLC	POLB	POLA
0x0612	CWG1AS0	7:0	SHUTDOWN	REN	LSBD[1:0]		LSAC[1:0]			
0x0613	CWG1AS1	7:0			AS5E	AS4E	AS3E	AS2E	AS1E	AS0E
0x0614	CWG1STR	7:0	OVRD	OVRC	OVRB	OVRA	STRD	STRC	STRB	STRA
0x0615	Reserved									
0x0616	CWG2CLK	7:0								CS
0x0617	CWG2ISM	7:0	ISM[3:0]							
0x0618	CWG2DBR	7:0	DBR[5:0]							
0x0619	CWG2DBF	7:0	DBF[5:0]							
0x061A	CWG2CON0	7:0	EN	LD			MODE[2:0]			
0x061B	CWG2CON1	7:0			IN		POLD	POLC	POLB	POLA
0x061C	CWG2AS0	7:0	SHUTDOWN	REN	LSBD[1:0]		LSAC[1:0]			
0x061D	CWG2AS1	7:0			AS5E	AS4E	AS3E	AS2E	AS1E	AS0E
0x061E	CWG2STR	7:0	OVRD	OVRC	OVRB	OVRA	STRD	STRC	STRB	STRA
0x061F ... 0x067F	Reserved									
0x0680	INDF0	7:0	INDF0[7:0]							
0x0681	INDF1	7:0	INDF1[7:0]							
0x0682	PCL	7:0	PCL[7:0]							
0x0683	STATUS	7:0			TO	PD	Z	DC	C	
0x0684	FSR0	7:0	FSRL[7:0]							
		15:8	FSRH[7:0]							
0x0686	FSR1	7:0	FSRL[7:0]							

# PIC16(L)F18455/56

## Register Summary

Address	Name	Bit Pos.								
		15:8	FSRH[7:0]							
0x0688	BSR	7:0	BSR[5:0]							
0x0689	WREG	7:0	WREG[7:0]							
0x068A	PCLATH	7:0	PCLATH[6:0]							
0x068B	INTCON	7:0	GIE	PEIE						INTEDG
0x068C	CWG3CLK	7:0								CS
0x068D	CWG3ISM	7:0					ISM[3:0]			
0x068E	CWG3DBR	7:0					DBR[5:0]			
0x068F	CWG3DBF	7:0					DBF[5:0]			
0x0690	CWG3CON0	7:0	EN	LD				MODE[2:0]		
0x0691	CWG3CON1	7:0			IN		POLD	POLC	POLB	POLA
0x0692	CWG3AS0	7:0	SHUTDOWN	REN	LSBD[1:0]		LSAC[1:0]			
0x0693	CWG3AS1	7:0			AS5E	AS4E	AS3E	AS2E	AS1E	AS0E
0x0694	CWG3STR	7:0	OVRD	OVRC	OVRB	OVRA	STRD	STRC	STRB	STRA
0x0695 ... 0x06FF	Reserved									
0x0700	INDF0	7:0	INDF0[7:0]							
0x0701	INDF1	7:0	INDF1[7:0]							
0x0702	PCL	7:0	PCL[7:0]							
0x0703	STATUS	7:0			TO	PD	Z	DC	C	
0x0704	FSR0	7:0	FSRL[7:0]							
		15:8	FSRH[7:0]							
0x0706	FSR1	7:0	FSRL[7:0]							
		15:8	FSRH[7:0]							
0x0708	BSR	7:0	BSR[5:0]							
0x0709	WREG	7:0	WREG[7:0]							
0x070A	PCLATH	7:0	PCLATH[6:0]							
0x070B	INTCON	7:0	GIE	PEIE						INTEDG
0x070C	PIR0	7:0			TMR0IF	IOCIF				INTF
0x070D	PIR1	7:0	OSFIF	CSWIF					ADTIF	ADIF
0x070E	PIR2	7:0		ZCDIF					C2IF	C1IF
0x070F	PIR3	7:0	RC2IF	TX2IF	RC1IF	TX1IF	BCL2IF	SSP2IF	BCL1IF	SSP1IF
0x0710	PIR4	7:0			TMR6IF	TMR5IF	TMR4IF	TMR3IF	TMR2IF	TMR1IF
0x0711	PIR5	7:0	CLC4IF	CLC3IF	CL24IF	CLC1IF		TMR5GIF	TMR3GIF	TMR1GIF
0x0712	PIR6	7:0				CCP5IF	CCP4IF	CCP3IF	CCP2IF	CCP1IF
0x0713	PIR7	7:0			NVMIF	NCO1IF		CWG3IF	CWG2IF	CWG1IF
0x0714	PIR8	7:0			SMT2PWAIF	SMT2PRAIF	SMT2IF	SMT1PWAIF	SMT1PRAIF	SMT1IF
0x0715	Reserved									
0x0716	PIE0	7:0			TMR0IE	IOCIE				INTE
0x0717	PIE1	7:0	OSFIE	CSWIE					ADTIE	ADIE
0x0718	PIE2	7:0		ZCDIE					C2IE	C1IE
0x0719	PIE3	7:0	RC2IE	TX2IE	RC1IE	TX1IE	BCL2IE	SSP2IE	BCL1IE	SSP1IE
0x071A	PIE4	7:0			TMR6IE	TMR5IE	TMR4IE	TMR3IE	TMR2IE	TMR1IE
0x071B	PIE5	7:0	CLC4IE	CLC3IE	CLC2IE	CLC1IE		TMR5GIE	TMR3GIE	TMR1GIE
0x071C	PIE6	7:0				CCP5IE	CCP4IE	CCP3IE	CCP2IE	CCP1IE

# PIC16(L)F18455/56

## Register Summary

Address	Name	Bit Pos.								
0x071D	PIE7	7:0			NVMIE	NCO1IE		CWG3IE	CWG2IE	CWG1IE
0x071E	PIE8	7:0			SMT2PWAIE	SMT2PRAIE	SMT2IE	SMT1PWAIE	SMT1PRAIE	SMT1IE
0x071F ... 0x077F	Reserved									
0x0780	INDF0	7:0	INDF0[7:0]							
0x0781	INDF1	7:0	INDF1[7:0]							
0x0782	PCL	7:0	PCL[7:0]							
0x0783	STATUS	7:0			T $\bar{O}$	P $\bar{D}$	Z	DC	C	
0x0784	FSR0	7:0	FSRL[7:0]							
		15:8	FSRH[7:0]							
0x0786	FSR1	7:0	FSRL[7:0]							
		15:8	FSRH[7:0]							
0x0788	BSR	7:0			BSR[5:0]					
0x0789	WREG	7:0	WREG[7:0]							
0x078A	PCLATH	7:0	PCLATH[6:0]							
0x078B	INTCON	7:0	GIE	PEIE						INTEDG
0x078C ... 0x0795	Reserved									
0x0796	PMD0	7:0	SYSCMD	FVRMD				NVMMD	CLKRMD	IOCMD
0x0797	PMD1	7:0		TMR6MD	TMR5MD	TMR4MD	TMR3MD	TMR2MD	TMR1MD	TMR0MD
0x0798	PMD2	7:0	NCO1MD							
0x0799	PMD3	7:0		DAC1MD	ADCMD			C2MD	C1MD	ZCDMD
0x079A	PMD4	7:0		PWM7MD	PWM6MD	CCP5MD	CCP4MD	CCP3MD	CCP2MD	CCP1MD
0x079B	PMD5	7:0	CWG3MD	CWG2MD	CWG1MD					
0x079C	PMD6	7:0			UART2MD	UART1MD			MSSP2MD	MSSP1MD
0x079D	PMD7	7:0		SMT2MD	SMT1MD	CLC4MD	CLC3MD	CLC2MD	CLC1MD	DSM1MD
0x079E ... 0x07FF	Reserved									
0x0800	INDF0	7:0	INDF0[7:0]							
0x0801	INDF1	7:0	INDF1[7:0]							
0x0802	PCL	7:0	PCL[7:0]							
0x0803	STATUS	7:0			T $\bar{O}$	P $\bar{D}$	Z	DC	C	
0x0804	FSR0	7:0	FSRL[7:0]							
		15:8	FSRH[7:0]							
0x0806	FSR1	7:0	FSRL[7:0]							
		15:8	FSRH[7:0]							
0x0808	BSR	7:0			BSR[5:0]					
0x0809	WREG	7:0	WREG[7:0]							
0x080A	PCLATH	7:0	PCLATH[6:0]							
0x080B	INTCON	7:0	GIE	PEIE						INTEDG
0x080C	WDTCN0	7:0			WDTPS[4:0]					SEN
0x080D	WDTCN1	7:0		WDTCS[2:0]				WINDOW[2:0]		
0x080E	WDTPSL	7:0	PSCNTL[7:0]							

# PIC16(L)F18455/56

## Register Summary

Address	Name	Bit Pos.										
0x080F	WDTPSH	7:0	PSCNTH[7:0]									
0x0810	WDTTMR	7:0	WDTTMR[4:0]					STATE	PSCNT[1:0]			
0x0811	BORCON	7:0	SBOREN								BORRDY	
0x0812	VREGCON	7:0							VREGPM			
0x0813	PCON0	7:0	STKOVF	STKUNF	WDTWV	RWDT	RMCLR	RI	POR	BOR		
0x0814	PCON1	7:0							MEMV			
0x0815	Reserved											
...												
0x0819												
0x081A	NVMADR	7:0	NVMADRL[7:0]									
		15:8		NVMADRH[6:0]								
0x081C	NVMDAT	7:0	NVMDATL[7:0]									
		15:8		NVMDATH[5:0]								
0x081E	NVMCON1	7:0		NVMREGS	LWLO	FREE	WRERR	WREN	WR	RD		
0x081F	NVMCON2	7:0	NVMCON2[7:0]									
0x0820	Reserved											
...												
0x087F												
0x0880	INDF0	7:0	INDF0[7:0]									
0x0881	INDF1	7:0	INDF1[7:0]									
0x0882	PCL	7:0	PCL[7:0]									
0x0883	STATUS	7:0				TO	PD	Z	DC	C		
0x0884	FSR0	7:0	FSRL[7:0]									
		15:8	FSRH[7:0]									
0x0886	FSR1	7:0	FSRL[7:0]									
		15:8	FSRH[7:0]									
0x0888	BSR	7:0		BSR[5:0]								
0x0889	WREG	7:0	WREG[7:0]									
0x088A	PCLATH	7:0		PCLATH[6:0]								
0x088B	INTCON	7:0	GIE	PEIE						INTEDG		
0x088C	CPUDOZE	7:0	IDLEN	DOZEN	ROI	DOE		DOZE[2:0]				
0x088D	OSCCON1	7:0		NOSC[2:0]			NDIV[3:0]					
0x088E	OSCCON2	7:0		COSC[2:0]			CDIV[3:0]					
0x088F	OSCCON3	7:0	CSWHOLD	SOSCPWR		ORDY	NOSCR					
0x0890	OSCSTAT	7:0	EXTOR	HFOR	MFOR	LFOR	SOR	ADOR		PLL		
0x0891	OSCEN	7:0	EXTOEN	HFOEN	MFOEN	LFOEN	SOSCEN	ADOEN				
0x0892	OSCTUNE	7:0		HFTUN[5:0]								
0x0893	OSCFRQ	7:0		HFFRQ[2:0]								
0x0894	Reserved											
0x0895	CLKRCON	7:0	EN		DC[1:0]			DIV[2:0]				
0x0896	CLKRCLK	7:0		CLK[3:0]								
0x0897	MD1CON0	7:0	EN		OUT	OPOL				BIT		
0x0898	MD1CON1	7:0			CHPOL	CHSYNC			CLPOL	CLSYNC		
0x0899	MD1SRC	7:0		SRCS[4:0]								
0x089A	MD1CARL	7:0		CLS[3:0]								
0x089B	MD1CARH	7:0		CHS[3:0]								

# PIC16(L)F18455/56

## Register Summary

Address	Name	Bit Pos.								
0x089C	Reserved									
...										
0x08FF										
0x0900	INDF0	7:0	INDF0[7:0]							
0x0901	INDF1	7:0	INDF1[7:0]							
0x0902	PCL	7:0	PCL[7:0]							
0x0903	STATUS	7:0			TO	PD	Z	DC	C	
0x0904	FSR0	7:0	FSRL[7:0]							
		15:8	FSRH[7:0]							
0x0906	FSR1	7:0	FSRL[7:0]							
		15:8	FSRH[7:0]							
0x0908	BSR	7:0			BSR[5:0]					
0x0909	WREG	7:0	WREG[7:0]							
0x090A	PCLATH	7:0		PCLATH[6:0]						
0x090B	INTCON	7:0	GIE	PEIE						INTEDG
0x090C	FVRCON	7:0	FVREN	FVRRDY	TSEN	TSRNG	CDAFVR[1:0]		ADFVR[1:0]	
0x090D	Reserved									
0x090E	DAC1CON0	7:0	EN		OE1	OE2	PSS[1:0]			NSS
0x090F	DAC1CON1	7:0			DAC1R[4:0]					
0x0910	Reserved									
...										
0x091E										
0x091F	ZCDCON	7:0	SEN		OUT	POL			INTP	INTN
0x0920	Reserved									
...										
0x097F										
0x0980	INDF0	7:0	INDF0[7:0]							
0x0981	INDF1	7:0	INDF1[7:0]							
0x0982	PCL	7:0	PCL[7:0]							
0x0983	STATUS	7:0			TO	PD	Z	DC	C	
0x0984	FSR0	7:0	FSRL[7:0]							
		15:8	FSRH[7:0]							
0x0986	FSR1	7:0	FSRL[7:0]							
		15:8	FSRH[7:0]							
0x0988	BSR	7:0			BSR[5:0]					
0x0989	WREG	7:0	WREG[7:0]							
0x098A	PCLATH	7:0		PCLATH[6:0]						
0x098B	INTCON	7:0	GIE	PEIE						INTEDG
0x098C	Reserved									
...										
0x098E										
0x098F	CMOUT	7:0						MC2OUT	MC1OUT	
0x0990	CM1CON0	7:0	EN	OUT		POL		HYS	SYNC	
0x0991	CM1CON1	7:0						INTP	INTN	
0x0992	CM1NCH	7:0						NCH[2:0]		
0x0993	CM1PCH	7:0						PCH[2:0]		

# PIC16(L)F18455/56

## Register Summary

Address	Name	Bit Pos.								
0x0994	CM2CON0	7:0	EN	OUT		POL			HYS	SYNC
0x0995	CM2CON1	7:0							INTP	INTN
0x0996	CM2NCH	7:0							NCH[2:0]	
0x0997	CM2PCH	7:0							PCH[2:0]	
0x0998 ... 0x09FF	Reserved									
0x0A00	INDF0	7:0	INDF0[7:0]							
0x0A01	INDF1	7:0	INDF1[7:0]							
0x0A02	PCL	7:0	PCL[7:0]							
0x0A03	STATUS	7:0				TO	PD	Z	DC	C
0x0A04	FSR0	7:0	FSRL[7:0]							
		15:8	FSRH[7:0]							
0x0A06	FSR1	7:0	FSRL[7:0]							
		15:8	FSRH[7:0]							
0x0A08	BSR	7:0	BSR[5:0]							
0x0A09	WREG	7:0	WREG[7:0]							
0x0A0A	PCLATH	7:0	PCLATH[6:0]							
0x0A0B	INTCON	7:0	GIE	PEIE						INTEDG
0x0A0C ... 0x0A18	Reserved									
0x0A19	RC2REG	7:0	RCREG[7:0]							
0x0A1A	TX2REG	7:0	TXREG[7:0]							
0x0A1B	SP2BRG	7:0	SPBRGL[7:0]							
		15:8	SPBRGH[7:0]							
0x0A1D	RC2STA	7:0	SPEN	RX9	SREN	CREN	ADDEN	FERR	OERR	RX9D
0x0A1E	TX2STA	7:0	CSRC	TX9	TXEN	SYNC	SENB	BRGH	TRMT	TX9D
0x0A1F	BAUD2CON	7:0	ABDOVF	RCIDL		SCKP	BRG16		WUE	ABDEN
0x0A20 ... 0x0A7F	Reserved									
0x0A80	INDF0	7:0	INDF0[7:0]							
0x0A81	INDF1	7:0	INDF1[7:0]							
0x0A82	PCL	7:0	PCL[7:0]							
0x0A83	STATUS	7:0				TO	PD	Z	DC	C
0x0A84	FSR0	7:0	FSRL[7:0]							
		15:8	FSRH[7:0]							
0x0A86	FSR1	7:0	FSRL[7:0]							
		15:8	FSRH[7:0]							
0x0A88	BSR	7:0	BSR[5:0]							
0x0A89	WREG	7:0	WREG[7:0]							
0x0A8A	PCLATH	7:0	PCLATH[6:0]							
0x0A8B	INTCON	7:0	GIE	PEIE						INTEDG
0x0A8C ...	Reserved									



# PIC16(L)F18455/56

## Register Summary

Address	Name	Bit Pos.									
0x0AFF											
0x0B00	INDF0	7:0									INDF0[7:0]
0x0B01	INDF1	7:0									INDF1[7:0]
0x0B02	PCL	7:0									PCL[7:0]
0x0B03	STATUS	7:0					$\overline{TO}$	$\overline{PD}$	Z	DC	C
0x0B04	FSR0	7:0									FSRL[7:0]
		15:8									FSRH[7:0]
0x0B06	FSR1	7:0									FSRL[7:0]
		15:8									FSRH[7:0]
0x0B08	BSR	7:0									BSR[5:0]
0x0B09	WREG	7:0									WREG[7:0]
0x0B0A	PCLATH	7:0									PCLATH[6:0]
0x0B0B	INTCON	7:0	GIE	PEIE							INTEDG
0x0B0C	Reserved										
0x0B7F											
0x0B80	INDF0	7:0									INDF0[7:0]
0x0B81	INDF1	7:0									INDF1[7:0]
0x0B82	PCL	7:0									PCL[7:0]
0x0B83	STATUS	7:0					$\overline{TO}$	$\overline{PD}$	Z	DC	C
0x0B84	FSR0	7:0									FSRL[7:0]
		15:8									FSRH[7:0]
0x0B86	FSR1	7:0									FSRL[7:0]
		15:8									FSRH[7:0]
0x0B88	BSR	7:0									BSR[5:0]
0x0B89	WREG	7:0									WREG[7:0]
0x0B8A	PCLATH	7:0									PCLATH[6:0]
0x0B8B	INTCON	7:0	GIE	PEIE							INTEDG
0x0B8C	Reserved										
0x0BFF											
0x0C00	INDF0	7:0									INDF0[7:0]
0x0C01	INDF1	7:0									INDF1[7:0]
0x0C02	PCL	7:0									PCL[7:0]
0x0C03	STATUS	7:0					$\overline{TO}$	$\overline{PD}$	Z	DC	C
0x0C04	FSR0	7:0									FSRL[7:0]
		15:8									FSRH[7:0]
0x0C06	FSR1	7:0									FSRL[7:0]
		15:8									FSRH[7:0]
0x0C08	BSR	7:0									BSR[5:0]
0x0C09	WREG	7:0									WREG[7:0]
0x0C0A	PCLATH	7:0									PCLATH[6:0]
0x0C0B	INTCON	7:0	GIE	PEIE							INTEDG
0x0C0C	Reserved										
0x0C7F											

# PIC16(L)F18455/56

## Register Summary

Address	Name	Bit Pos.									
0x0C80	INDF0	7:0	INDF0[7:0]								
0x0C81	INDF1	7:0	INDF1[7:0]								
0x0C82	PCL	7:0	PCL[7:0]								
0x0C83	STATUS	7:0				$\overline{TO}$	$\overline{PD}$	Z	DC	C	
0x0C84	FSR0	7:0	FSRL[7:0]								
		15:8	FSRH[7:0]								
0x0C86	FSR1	7:0	FSRL[7:0]								
		15:8	FSRH[7:0]								
0x0C88	BSR	7:0	BSR[5:0]								
0x0C89	WREG	7:0	WREG[7:0]								
0x0C8A	PCLATH	7:0	PCLATH[6:0]								
0x0C8B	INTCON	7:0	GIE	PEIE						INTEDG	
0x0C8C	Reserved										
0x0CFF											
0x0D00	INDF0	7:0	INDF0[7:0]								
0x0D01	INDF1	7:0	INDF1[7:0]								
0x0D02	PCL	7:0	PCL[7:0]								
0x0D03	STATUS	7:0				$\overline{TO}$	$\overline{PD}$	Z	DC	C	
0x0D04	FSR0	7:0	FSRL[7:0]								
		15:8	FSRH[7:0]								
0x0D06	FSR1	7:0	FSRL[7:0]								
		15:8	FSRH[7:0]								
0x0D08	BSR	7:0	BSR[5:0]								
0x0D09	WREG	7:0	WREG[7:0]								
0x0D0A	PCLATH	7:0	PCLATH[6:0]								
0x0D0B	INTCON	7:0	GIE	PEIE						INTEDG	
0x0D0C	Reserved										
0x0D7F											
0x0D80	INDF0	7:0	INDF0[7:0]								
0x0D81	INDF1	7:0	INDF1[7:0]								
0x0D82	PCL	7:0	PCL[7:0]								
0x0D83	STATUS	7:0				$\overline{TO}$	$\overline{PD}$	Z	DC	C	
0x0D84	FSR0	7:0	FSRL[7:0]								
		15:8	FSRH[7:0]								
0x0D86	FSR1	7:0	FSRL[7:0]								
		15:8	FSRH[7:0]								
0x0D88	BSR	7:0	BSR[5:0]								
0x0D89	WREG	7:0	WREG[7:0]								
0x0D8A	PCLATH	7:0	PCLATH[6:0]								
0x0D8B	INTCON	7:0	GIE	PEIE						INTEDG	
0x0D8C	Reserved										
0x0DFF											
0x0E00	INDF0	7:0	INDF0[7:0]								

# PIC16(L)F18455/56

## Register Summary

Address	Name	Bit Pos.									
0x0E01	INDF1	7:0	INDF1[7:0]								
0x0E02	PCL	7:0	PCL[7:0]								
0x0E03	STATUS	7:0				T $\bar{O}$	P $\bar{D}$	Z	DC	C	
0x0E04	FSR0	7:0	FSRL[7:0]								
		15:8	FSRH[7:0]								
0x0E06	FSR1	7:0	FSRL[7:0]								
		15:8	FSRH[7:0]								
0x0E08	BSR	7:0	BSR[5:0]								
0x0E09	WREG	7:0	WREG[7:0]								
0x0E0A	PCLATH	7:0	PCLATH[6:0]								
0x0E0B	INTCON	7:0	GIE	PEIE							INTEDG
0x0E0C	Reserved										
0x0E7F											
0x0E80	INDF0	7:0	INDF0[7:0]								
0x0E81	INDF1	7:0	INDF1[7:0]								
0x0E82	PCL	7:0	PCL[7:0]								
0x0E83	STATUS	7:0				T $\bar{O}$	P $\bar{D}$	Z	DC	C	
0x0E84	FSR0	7:0	FSRL[7:0]								
		15:8	FSRH[7:0]								
0x0E86	FSR1	7:0	FSRL[7:0]								
		15:8	FSRH[7:0]								
0x0E88	BSR	7:0	BSR[5:0]								
0x0E89	WREG	7:0	WREG[7:0]								
0x0E8A	PCLATH	7:0	PCLATH[6:0]								
0x0E8B	INTCON	7:0	GIE	PEIE							INTEDG
0x0E8C	Reserved										
0x0EFF											
0x0F00	INDF0	7:0	INDF0[7:0]								
0x0F01	INDF1	7:0	INDF1[7:0]								
0x0F02	PCL	7:0	PCL[7:0]								
0x0F03	STATUS	7:0				T $\bar{O}$	P $\bar{D}$	Z	DC	C	
0x0F04	FSR0	7:0	FSRL[7:0]								
		15:8	FSRH[7:0]								
0x0F06	FSR1	7:0	FSRL[7:0]								
		15:8	FSRH[7:0]								
0x0F08	BSR	7:0	BSR[5:0]								
0x0F09	WREG	7:0	WREG[7:0]								
0x0F0A	PCLATH	7:0	PCLATH[6:0]								
0x0F0B	INTCON	7:0	GIE	PEIE							INTEDG
0x0F0C	Reserved										
0x0F7F											
0x0F80	INDF0	7:0	INDF0[7:0]								
0x0F81	INDF1	7:0	INDF1[7:0]								

# PIC16(L)F18455/56

## Register Summary

Address	Name	Bit Pos.									
0x0F82	PCL	7:0	PCL[7:0]								
0x0F83	STATUS	7:0				T $\bar{O}$	PD	Z	DC	C	
0x0F84	FSR0	7:0	FSRL[7:0]								
		15:8	FSRH[7:0]								
0x0F86	FSR1	7:0	FSRL[7:0]								
		15:8	FSRH[7:0]								
0x0F88	BSR	7:0	BSR[5:0]								
0x0F89	WREG	7:0	WREG[7:0]								
0x0F8A	PCLATH	7:0	PCLATH[6:0]								
0x0F8B	INTCON	7:0	GIE	PEIE						INTEDG	
0x0F8C ... 0x0FFF	Reserved										
0x1000	INDF0	7:0	INDF0[7:0]								
0x1001	INDF1	7:0	INDF1[7:0]								
0x1002	PCL	7:0	PCL[7:0]								
0x1003	STATUS	7:0				T $\bar{O}$	PD	Z	DC	C	
0x1004	FSR0	7:0	FSRL[7:0]								
		15:8	FSRH[7:0]								
0x1006	FSR1	7:0	FSRL[7:0]								
		15:8	FSRH[7:0]								
0x1008	BSR	7:0	BSR[5:0]								
0x1009	WREG	7:0	WREG[7:0]								
0x100A	PCLATH	7:0	PCLATH[6:0]								
0x100B	INTCON	7:0	GIE	PEIE						INTEDG	
0x100C ... 0x107F	Reserved										
0x1080	INDF0	7:0	INDF0[7:0]								
0x1081	INDF1	7:0	INDF1[7:0]								
0x1082	PCL	7:0	PCL[7:0]								
0x1083	STATUS	7:0				T $\bar{O}$	PD	Z	DC	C	
0x1084	FSR0	7:0	FSRL[7:0]								
		15:8	FSRH[7:0]								
0x1086	FSR1	7:0	FSRL[7:0]								
		15:8	FSRH[7:0]								
0x1088	BSR	7:0	BSR[5:0]								
0x1089	WREG	7:0	WREG[7:0]								
0x108A	PCLATH	7:0	PCLATH[6:0]								
0x108B	INTCON	7:0	GIE	PEIE						INTEDG	
0x108C ... 0x10FF	Reserved										
0x1100	INDF0	7:0	INDF0[7:0]								
0x1101	INDF1	7:0	INDF1[7:0]								
0x1102	PCL	7:0	PCL[7:0]								

# PIC16(L)F18455/56

## Register Summary

Address	Name	Bit Pos.								
0x1103	STATUS	7:0				T $\bar{O}$	P $\bar{D}$	Z	DC	C
0x1104	FSR0	7:0	FSRL[7:0]							
		15:8	FSRH[7:0]							
0x1106	FSR1	7:0	FSRL[7:0]							
		15:8	FSRH[7:0]							
0x1108	BSR	7:0	BSR[5:0]							
0x1109	WREG	7:0	WREG[7:0]							
0x110A	PCLATH	7:0	PCLATH[6:0]							
0x110B	INTCON	7:0	GIE	PEIE						INTEDG
0x110C	Reserved									
...										
0x1117F										
0x1180	INDF0	7:0	INDF0[7:0]							
0x1181	INDF1	7:0	INDF1[7:0]							
0x1182	PCL	7:0	PCL[7:0]							
0x1183	STATUS	7:0				T $\bar{O}$	P $\bar{D}$	Z	DC	C
0x1184	FSR0	7:0	FSRL[7:0]							
		15:8	FSRH[7:0]							
0x1186	FSR1	7:0	FSRL[7:0]							
		15:8	FSRH[7:0]							
0x1188	BSR	7:0	BSR[5:0]							
0x1189	WREG	7:0	WREG[7:0]							
0x118A	PCLATH	7:0	PCLATH[6:0]							
0x118B	INTCON	7:0	GIE	PEIE						INTEDG
0x118C	Reserved									
...										
0x11FF										
0x1200	INDF0	7:0	INDF0[7:0]							
0x1201	INDF1	7:0	INDF1[7:0]							
0x1202	PCL	7:0	PCL[7:0]							
0x1203	STATUS	7:0				T $\bar{O}$	P $\bar{D}$	Z	DC	C
0x1204	FSR0	7:0	FSRL[7:0]							
		15:8	FSRH[7:0]							
0x1206	FSR1	7:0	FSRL[7:0]							
		15:8	FSRH[7:0]							
0x1208	BSR	7:0	BSR[5:0]							
0x1209	WREG	7:0	WREG[7:0]							
0x120A	PCLATH	7:0	PCLATH[6:0]							
0x120B	INTCON	7:0	GIE	PEIE						INTEDG
0x120C	Reserved									
...										
0x127F										
0x1280	INDF0	7:0	INDF0[7:0]							
0x1281	INDF1	7:0	INDF1[7:0]							
0x1282	PCL	7:0	PCL[7:0]							
0x1283	STATUS	7:0				T $\bar{O}$	P $\bar{D}$	Z	DC	C

# PIC16(L)F18455/56

## Register Summary

Address	Name	Bit Pos.									
0x1284	FSR0	7:0	FSRL[7:0]								
		15:8	FSRH[7:0]								
0x1286	FSR1	7:0	FSRL[7:0]								
		15:8	FSRH[7:0]								
0x1288	BSR	7:0	BSR[5:0]								
0x1289	WREG	7:0	WREG[7:0]								
0x128A	PCLATH	7:0	PCLATH[6:0]								
0x128B	INTCON	7:0	GIE	PEIE							INTEDG
0x128C	Reserved										
...											
0x12FF											
0x1300	INDF0	7:0	INDF0[7:0]								
0x1301	INDF1	7:0	INDF1[7:0]								
0x1302	PCL	7:0	PCL[7:0]								
0x1303	STATUS	7:0				TO	PD	Z	DC	C	
0x1304	FSR0	7:0	FSRL[7:0]								
		15:8	FSRH[7:0]								
0x1306	FSR1	7:0	FSRL[7:0]								
		15:8	FSRH[7:0]								
0x1308	BSR	7:0	BSR[5:0]								
0x1309	WREG	7:0	WREG[7:0]								
0x130A	PCLATH	7:0	PCLATH[6:0]								
0x130B	INTCON	7:0	GIE	PEIE							INTEDG
0x130C	Reserved										
...											
0x137F											
0x1380	INDF0	7:0	INDF0[7:0]								
0x1381	INDF1	7:0	INDF1[7:0]								
0x1382	PCL	7:0	PCL[7:0]								
0x1383	STATUS	7:0				TO	PD	Z	DC	C	
0x1384	FSR0	7:0	FSRL[7:0]								
		15:8	FSRH[7:0]								
0x1386	FSR1	7:0	FSRL[7:0]								
		15:8	FSRH[7:0]								
0x1388	BSR	7:0	BSR[5:0]								
0x1389	WREG	7:0	WREG[7:0]								
0x138A	PCLATH	7:0	PCLATH[6:0]								
0x138B	INTCON	7:0	GIE	PEIE							INTEDG
0x138C	Reserved										
...											
0x13FF											
0x1400	INDF0	7:0	INDF0[7:0]								
0x1401	INDF1	7:0	INDF1[7:0]								
0x1402	PCL	7:0	PCL[7:0]								
0x1403	STATUS	7:0				TO	PD	Z	DC	C	
0x1404	FSR0	7:0	FSRL[7:0]								

# PIC16(L)F18455/56

## Register Summary

Address	Name	Bit Pos.									
0x1406	FSR1	15:8	FSRH[7:0]								
		7:0	FSRL[7:0]								
		15:8	FSRH[7:0]								
0x1408	BSR	7:0			BSR[5:0]						
0x1409	WREG	7:0	WREG[7:0]								
0x140A	PCLATH	7:0		PCLATH[6:0]							
0x140B	INTCON	7:0	GIE	PEIE							INTEDG
0x140C	Reserved										
...											
0x147F											
0x1480	INDF0	7:0	INDF0[7:0]								
0x1481	INDF1	7:0	INDF1[7:0]								
0x1482	PCL	7:0	PCL[7:0]								
0x1483	STATUS	7:0				T $\bar{O}$	P $\bar{D}$	Z	DC	C	
0x1484	FSR0	7:0	FSRL[7:0]								
		15:8	FSRH[7:0]								
0x1486	FSR1	7:0	FSRL[7:0]								
		15:8	FSRH[7:0]								
0x1488	BSR	7:0			BSR[5:0]						
0x1489	WREG	7:0	WREG[7:0]								
0x148A	PCLATH	7:0		PCLATH[6:0]							
0x148B	INTCON	7:0	GIE	PEIE							INTEDG
0x148C	Reserved										
...											
0x14FF											
0x1500	INDF0	7:0	INDF0[7:0]								
0x1501	INDF1	7:0	INDF1[7:0]								
0x1502	PCL	7:0	PCL[7:0]								
0x1503	STATUS	7:0				T $\bar{O}$	P $\bar{D}$	Z	DC	C	
0x1504	FSR0	7:0	FSRL[7:0]								
		15:8	FSRH[7:0]								
0x1506	FSR1	7:0	FSRL[7:0]								
		15:8	FSRH[7:0]								
0x1508	BSR	7:0			BSR[5:0]						
0x1509	WREG	7:0	WREG[7:0]								
0x150A	PCLATH	7:0		PCLATH[6:0]							
0x150B	INTCON	7:0	GIE	PEIE							INTEDG
0x150C	Reserved										
...											
0x157F											
0x1580	INDF0	7:0	INDF0[7:0]								
0x1581	INDF1	7:0	INDF1[7:0]								
0x1582	PCL	7:0	PCL[7:0]								
0x1583	STATUS	7:0				T $\bar{O}$	P $\bar{D}$	Z	DC	C	
0x1584	FSR0	7:0	FSRL[7:0]								
		15:8	FSRH[7:0]								

# PIC16(L)F18455/56

## Register Summary

Address	Name	Bit Pos.									
0x1586	FSR1	7:0	FSRL[7:0]								
		15:8	FSRH[7:0]								
0x1588	BSR	7:0	BSR[5:0]								
0x1589	WREG	7:0	WREG[7:0]								
0x158A	PCLATH	7:0	PCLATH[6:0]								
0x158B	INTCON	7:0	GIE	PEIE							INTEDG
0x158C	Reserved										
...											
0x15FF											
0x1600	INDF0	7:0	INDF0[7:0]								
0x1601	INDF1	7:0	INDF1[7:0]								
0x1602	PCL	7:0	PCL[7:0]								
0x1603	STATUS	7:0				T $\bar{O}$	P $\bar{D}$	Z	DC	C	
0x1604	FSR0	7:0	FSRL[7:0]								
		15:8	FSRH[7:0]								
0x1606	FSR1	7:0	FSRL[7:0]								
		15:8	FSRH[7:0]								
0x1608	BSR	7:0	BSR[5:0]								
0x1609	WREG	7:0	WREG[7:0]								
0x160A	PCLATH	7:0	PCLATH[6:0]								
0x160B	INTCON	7:0	GIE	PEIE							INTEDG
0x160C	Reserved										
...											
0x167F											
0x1680	INDF0	7:0	INDF0[7:0]								
0x1681	INDF1	7:0	INDF1[7:0]								
0x1682	PCL	7:0	PCL[7:0]								
0x1683	STATUS	7:0				T $\bar{O}$	P $\bar{D}$	Z	DC	C	
0x1684	FSR0	7:0	FSRL[7:0]								
		15:8	FSRH[7:0]								
0x1686	FSR1	7:0	FSRL[7:0]								
		15:8	FSRH[7:0]								
0x1688	BSR	7:0	BSR[5:0]								
0x1689	WREG	7:0	WREG[7:0]								
0x168A	PCLATH	7:0	PCLATH[6:0]								
0x168B	INTCON	7:0	GIE	PEIE							INTEDG
0x168C	Reserved										
...											
0x16FF											
0x1700	INDF0	7:0	INDF0[7:0]								
0x1701	INDF1	7:0	INDF1[7:0]								
0x1702	PCL	7:0	PCL[7:0]								
0x1703	STATUS	7:0				T $\bar{O}$	P $\bar{D}$	Z	DC	C	
0x1704	FSR0	7:0	FSRL[7:0]								
		15:8	FSRH[7:0]								
0x1706	FSR1	7:0	FSRL[7:0]								



# PIC16(L)F18455/56

## Register Summary

Address	Name	Bit Pos.								
		15:8	FSRH[7:0]							
0x1708	BSR	7:0	BSR[5:0]							
0x1709	WREG	7:0	WREG[7:0]							
0x170A	PCLATH	7:0	PCLATH[6:0]							
0x170B	INTCON	7:0	GIE	PEIE						INTEDG
0x170C ... 0x177F	Reserved									
0x1780	INDF0	7:0	INDF0[7:0]							
0x1781	INDF1	7:0	INDF1[7:0]							
0x1782	PCL	7:0	PCL[7:0]							
0x1783	STATUS	7:0				TO	PD	Z	DC	C
0x1784	FSR0	7:0	FSRL[7:0]							
		15:8	FSRH[7:0]							
0x1786	FSR1	7:0	FSRL[7:0]							
		15:8	FSRH[7:0]							
0x1788	BSR	7:0	BSR[5:0]							
0x1789	WREG	7:0	WREG[7:0]							
0x178A	PCLATH	7:0	PCLATH[6:0]							
0x178B	INTCON	7:0	GIE	PEIE						INTEDG
0x178C ... 0x17FF	Reserved									
0x1800	INDF0	7:0	INDF0[7:0]							
0x1801	INDF1	7:0	INDF1[7:0]							
0x1802	PCL	7:0	PCL[7:0]							
0x1803	STATUS	7:0				TO	PD	Z	DC	C
0x1804	FSR0	7:0	FSRL[7:0]							
		15:8	FSRH[7:0]							
0x1806	FSR1	7:0	FSRL[7:0]							
		15:8	FSRH[7:0]							
0x1808	BSR	7:0	BSR[5:0]							
0x1809	WREG	7:0	WREG[7:0]							
0x180A	PCLATH	7:0	PCLATH[6:0]							
0x180B	INTCON	7:0	GIE	PEIE						INTEDG
0x180C ... 0x187F	Reserved									
0x1880	INDF0	7:0	INDF0[7:0]							
0x1881	INDF1	7:0	INDF1[7:0]							
0x1882	PCL	7:0	PCL[7:0]							
0x1883	STATUS	7:0				TO	PD	Z	DC	C
0x1884	FSR0	7:0	FSRL[7:0]							
		15:8	FSRH[7:0]							
0x1886	FSR1	7:0	FSRL[7:0]							
		15:8	FSRH[7:0]							

# PIC16(L)F18455/56

## Register Summary

Address	Name	Bit Pos.								
0x1888	BSR	7:0			BSR[5:0]					
0x1889	WREG	7:0			WREG[7:0]					
0x188A	PCLATH	7:0			PCLATH[6:0]					
0x188B	INTCON	7:0	GIE	PEIE						INTEDG
0x188C ... 0x18FF	Reserved									
0x1900	INDF0	7:0			INDF0[7:0]					
0x1901	INDF1	7:0			INDF1[7:0]					
0x1902	PCL	7:0			PCL[7:0]					
0x1903	STATUS	7:0			$\overline{TO}$	$\overline{PD}$	Z	DC	C	
0x1904	FSR0	7:0			FSRL[7:0]					
		15:8			FSRH[7:0]					
0x1906	FSR1	7:0			FSRL[7:0]					
		15:8			FSRH[7:0]					
0x1908	BSR	7:0			BSR[5:0]					
0x1909	WREG	7:0			WREG[7:0]					
0x190A	PCLATH	7:0			PCLATH[6:0]					
0x190B	INTCON	7:0	GIE	PEIE						INTEDG
0x190C ... 0x197F	Reserved									
0x1980	INDF0	7:0			INDF0[7:0]					
0x1981	INDF1	7:0			INDF1[7:0]					
0x1982	PCL	7:0			PCL[7:0]					
0x1983	STATUS	7:0			$\overline{TO}$	$\overline{PD}$	Z	DC	C	
0x1984	FSR0	7:0			FSRL[7:0]					
		15:8			FSRH[7:0]					
0x1986	FSR1	7:0			FSRL[7:0]					
		15:8			FSRH[7:0]					
0x1988	BSR	7:0			BSR[5:0]					
0x1989	WREG	7:0			WREG[7:0]					
0x198A	PCLATH	7:0			PCLATH[6:0]					
0x198B	INTCON	7:0	GIE	PEIE						INTEDG
0x198C ... 0x19FF	Reserved									
0x1A00	INDF0	7:0			INDF0[7:0]					
0x1A01	INDF1	7:0			INDF1[7:0]					
0x1A02	PCL	7:0			PCL[7:0]					
0x1A03	STATUS	7:0			$\overline{TO}$	$\overline{PD}$	Z	DC	C	
0x1A04	FSR0	7:0			FSRL[7:0]					
		15:8			FSRH[7:0]					
0x1A06	FSR1	7:0			FSRL[7:0]					
		15:8			FSRH[7:0]					
0x1A08	BSR	7:0			BSR[5:0]					

# PIC16(L)F18455/56

## Register Summary

Address	Name	Bit Pos.							
0x1A09	WREG	7:0	WREG[7:0]						
0x1A0A	PCLATH	7:0	PCLATH[6:0]						
0x1A0B	INTCON	7:0	GIE	PEIE					INTEDG
0x1A0C ... 0x1A7F	Reserved								
0x1A80	INDF0	7:0	INDF0[7:0]						
0x1A81	INDF1	7:0	INDF1[7:0]						
0x1A82	PCL	7:0	PCL[7:0]						
0x1A83	STATUS	7:0			T $\bar{O}$	P $\bar{D}$	Z	DC	C
0x1A84	FSR0	7:0	FSRL[7:0]						
		15:8	FSRH[7:0]						
0x1A86	FSR1	7:0	FSRL[7:0]						
		15:8	FSRH[7:0]						
0x1A88	BSR	7:0	BSR[5:0]						
0x1A89	WREG	7:0	WREG[7:0]						
0x1A8A	PCLATH	7:0	PCLATH[6:0]						
0x1A8B	INTCON	7:0	GIE	PEIE					INTEDG
0x1A8C ... 0x1AFF	Reserved								
0x1B00	INDF0	7:0	INDF0[7:0]						
0x1B01	INDF1	7:0	INDF1[7:0]						
0x1B02	PCL	7:0	PCL[7:0]						
0x1B03	STATUS	7:0			T $\bar{O}$	P $\bar{D}$	Z	DC	C
0x1B04	FSR0	7:0	FSRL[7:0]						
		15:8	FSRH[7:0]						
0x1B06	FSR1	7:0	FSRL[7:0]						
		15:8	FSRH[7:0]						
0x1B08	BSR	7:0	BSR[5:0]						
0x1B09	WREG	7:0	WREG[7:0]						
0x1B0A	PCLATH	7:0	PCLATH[6:0]						
0x1B0B	INTCON	7:0	GIE	PEIE					INTEDG
0x1B0C ... 0x1B7F	Reserved								
0x1B80	INDF0	7:0	INDF0[7:0]						
0x1B81	INDF1	7:0	INDF1[7:0]						
0x1B82	PCL	7:0	PCL[7:0]						
0x1B83	STATUS	7:0			T $\bar{O}$	P $\bar{D}$	Z	DC	C
0x1B84	FSR0	7:0	FSRL[7:0]						
		15:8	FSRH[7:0]						
0x1B86	FSR1	7:0	FSRL[7:0]						
		15:8	FSRH[7:0]						
0x1B88	BSR	7:0	BSR[5:0]						
0x1B89	WREG	7:0	WREG[7:0]						

# PIC16(L)F18455/56

## Register Summary

Address	Name	Bit Pos.									
0x1B8A	PCLATH	7:0			PCLATH[6:0]						
0x1B8B	INTCON	7:0	GIE	PEIE						INTEDG	
0x1B8C ... 0x1BFF	Reserved										
0x1C00	INDF0	7:0			INDF0[7:0]						
0x1C01	INDF1	7:0			INDF1[7:0]						
0x1C02	PCL	7:0			PCL[7:0]						
0x1C03	STATUS	7:0			$\overline{TO}$	$\overline{PD}$	Z	DC	C		
0x1C04	FSR0	7:0			FSRL[7:0]						
		15:8			FSRH[7:0]						
0x1C06	FSR1	7:0			FSRL[7:0]						
		15:8			FSRH[7:0]						
0x1C08	BSR	7:0			BSR[5:0]						
0x1C09	WREG	7:0			WREG[7:0]						
0x1C0A	PCLATH	7:0			PCLATH[6:0]						
0x1C0B	INTCON	7:0	GIE	PEIE						INTEDG	
0x1C0C ... 0x1C7F	Reserved										
0x1C80	INDF0	7:0			INDF0[7:0]						
0x1C81	INDF1	7:0			INDF1[7:0]						
0x1C82	PCL	7:0			PCL[7:0]						
0x1C83	STATUS	7:0			$\overline{TO}$	$\overline{PD}$	Z	DC	C		
0x1C84	FSR0	7:0			FSRL[7:0]						
		15:8			FSRH[7:0]						
0x1C86	FSR1	7:0			FSRL[7:0]						
		15:8			FSRH[7:0]						
0x1C88	BSR	7:0			BSR[5:0]						
0x1C89	WREG	7:0			WREG[7:0]						
0x1C8A	PCLATH	7:0			PCLATH[6:0]						
0x1C8B	INTCON	7:0	GIE	PEIE						INTEDG	
0x1C8C ... 0x1CFF	Reserved										
0x1D00	INDF0	7:0			INDF0[7:0]						
0x1D01	INDF1	7:0			INDF1[7:0]						
0x1D02	PCL	7:0			PCL[7:0]						
0x1D03	STATUS	7:0			$\overline{TO}$	$\overline{PD}$	Z	DC	C		
0x1D04	FSR0	7:0			FSRL[7:0]						
		15:8			FSRH[7:0]						
0x1D06	FSR1	7:0			FSRL[7:0]						
		15:8			FSRH[7:0]						
0x1D08	BSR	7:0			BSR[5:0]						
0x1D09	WREG	7:0			WREG[7:0]						
0x1D0A	PCLATH	7:0			PCLATH[6:0]						

# PIC16(L)F18455/56

## Register Summary

Address	Name	Bit Pos.								
0x1D0B	INTCON	7:0	GIE	PEIE						INTEDG
0x1D0C ... 0x1D7F	Reserved									
0x1D80	INDF0	7:0	INDF0[7:0]							
0x1D81	INDF1	7:0	INDF1[7:0]							
0x1D82	PCL	7:0	PCL[7:0]							
0x1D83	STATUS	7:0				$\overline{TO}$	$\overline{PD}$	Z	DC	C
0x1D84	FSR0	7:0	FSRL[7:0]							
		15:8	FSRH[7:0]							
0x1D86	FSR1	7:0	FSRL[7:0]							
		15:8	FSRH[7:0]							
0x1D88	BSR	7:0	BSR[5:0]							
0x1D89	WREG	7:0	WREG[7:0]							
0x1D8A	PCLATH	7:0	PCLATH[6:0]							
0x1D8B	INTCON	7:0	GIE	PEIE						INTEDG
0x1D8C ... 0x1DFF	Reserved									
0x1E00	INDF0	7:0	INDF0[7:0]							
0x1E01	INDF1	7:0	INDF1[7:0]							
0x1E02	PCL	7:0	PCL[7:0]							
0x1E03	STATUS	7:0				$\overline{TO}$	$\overline{PD}$	Z	DC	C
0x1E04	FSR0	7:0	FSRL[7:0]							
		15:8	FSRH[7:0]							
0x1E06	FSR1	7:0	FSRL[7:0]							
		15:8	FSRH[7:0]							
0x1E08	BSR	7:0	BSR[5:0]							
0x1E09	WREG	7:0	WREG[7:0]							
0x1E0A	PCLATH	7:0	PCLATH[6:0]							
0x1E0B	INTCON	7:0	GIE	PEIE						INTEDG
0x1E0C ... 0x1E0E	Reserved									
0x1E0F	CLCDATA	7:0					MLC4OUT	MLC3OUT	MLC2OUT	MLC1OUT
0x1E10	CLC1CON	7:0	EN		OUT	INTP	INTN	MODE[2:0]		
0x1E11	CLC1POL	7:0	POL				G4POL	G3POL	G2POL	G1POL
0x1E12	CLC1SEL0	7:0	D1S[5:0]							
0x1E13	CLC1SEL1	7:0	D2S[5:0]							
0x1E14	CLC1SEL2	7:0	D3S[5:0]							
0x1E15	CLC1SEL3	7:0	D4S[5:0]							
0x1E16	CLC1GLS0	7:0	G1D4T	G1D4N	G1D3T	G1D3N	G1D2T	G1D2N	G1D1T	G1D1N
0x1E17	CLC1GLS1	7:0	G2D4T	G2D4N	G2D3T	G2D3N	G2D2T	G2D2N	G2D1T	G2D1N
0x1E18	CLC1GLS2	7:0	G3D4T	G3D4N	G3D3T	G3D3N	G3D2T	G3D2N	G3D1T	G3D1N
0x1E19	CLC1GLS3	7:0	G4D4T	G4D4N	G4D3T	G4D3N	G4D2T	G4D2N	G4D1T	G4D1N
0x1E1A	CLC2CON	7:0	EN		OUT	INTP	INTN	MODE[2:0]		

# PIC16(L)F18455/56

## Register Summary

Address	Name	Bit Pos.									
0x1E1B	CLC2POL	7:0	POL					G4POL	G3POL	G2POL	G1POL
0x1E1C	CLC2SEL0	7:0						D1S[5:0]			
0x1E1D	CLC2SEL1	7:0						D2S[5:0]			
0x1E1E	CLC2SEL2	7:0						D3S[5:0]			
0x1E1F	CLC2SEL3	7:0						D4S[5:0]			
0x1E20	CLC2GLS0	7:0	G1D4T	G1D4N	G1D3T	G1D3N	G1D2T	G1D2N	G1D1T	G1D1N	
0x1E21	CLC2GLS1	7:0	G2D4T	G2D4N	G2D3T	G2D3N	G2D2T	G2D2N	G2D1T	G2D1N	
0x1E22	CLC2GLS2	7:0	G3D4T	G3D4N	G3D3T	G3D3N	G3D2T	G3D2N	G3D1T	G3D1N	
0x1E23	CLC2GLS3	7:0	G4D4T	G4D4N	G4D3T	G4D3N	G4D2T	G4D2N	G4D1T	G4D1N	
0x1E24	CLC3CON	7:0	EN		OUT	INTP	INTN	MODE[2:0]			
0x1E25	CLC3POL	7:0	POL					G4POL	G3POL	G2POL	G1POL
0x1E26	CLC3SEL0	7:0						D1S[5:0]			
0x1E27	CLC3SEL1	7:0						D2S[5:0]			
0x1E28	CLC3SEL2	7:0						D3S[5:0]			
0x1E29	CLC3SEL3	7:0						D4S[5:0]			
0x1E2A	CLC3GLS0	7:0	G1D4T	G1D4N	G1D3T	G1D3N	G1D2T	G1D2N	G1D1T	G1D1N	
0x1E2B	CLC3GLS1	7:0	G2D4T	G2D4N	G2D3T	G2D3N	G2D2T	G2D2N	G2D1T	G2D1N	
0x1E2C	CLC3GLS2	7:0	G3D4T	G3D4N	G3D3T	G3D3N	G3D2T	G3D2N	G3D1T	G3D1N	
0x1E2D	CLC3GLS3	7:0	G4D4T	G4D4N	G4D3T	G4D3N	G4D2T	G4D2N	G4D1T	G4D1N	
0x1E2E	CLC4CON	7:0	EN		OUT	INTP	INTN	MODE[2:0]			
0x1E2F	CLC4POL	7:0	POL					G4POL	G3POL	G2POL	G1POL
0x1E30	CLC4SEL0	7:0						D1S[5:0]			
0x1E31	CLC4SEL1	7:0						D2S[5:0]			
0x1E32	CLC4SEL2	7:0						D3S[5:0]			
0x1E33	CLC4SEL3	7:0						D4S[5:0]			
0x1E34	CLC4GLS0	7:0	G1D4T	G1D4N	G1D3T	G1D3N	G1D2T	G1D2N	G1D1T	G1D1N	
0x1E35	CLC4GLS1	7:0	G2D4T	G2D4N	G2D3T	G2D3N	G2D2T	G2D2N	G2D1T	G2D1N	
0x1E36	CLC4GLS2	7:0	G3D4T	G3D4N	G3D3T	G3D3N	G3D2T	G3D2N	G3D1T	G3D1N	
0x1E37	CLC4GLS3	7:0	G4D4T	G4D4N	G4D3T	G4D3N	G4D2T	G4D2N	G4D1T	G4D1N	
0x1E38 ... 0x1E7F	Reserved										
0x1E80	INDF0	7:0	INDF0[7:0]								
0x1E81	INDF1	7:0	INDF1[7:0]								
0x1E82	PCL	7:0	PCL[7:0]								
0x1E83	STATUS	7:0				TO	PD	Z	DC	C	
0x1E84	FSR0	7:0	FSRL[7:0]								
		15:8	FSRH[7:0]								
0x1E86	FSR1	7:0	FSRL[7:0]								
		15:8	FSRH[7:0]								
0x1E88	BSR	7:0	BSR[5:0]								
0x1E89	WREG	7:0	WREG[7:0]								
0x1E8A	PCLATH	7:0	PCLATH[6:0]								
0x1E8B	INTCON	7:0	GIE	PEIE							INTEDG
0x1E8C ...	Reserved										

# PIC16(L)F18455/56

## Register Summary

Address	Name	Bit Pos.							
0x1E8E									
0x1E8F	PPSLOCK	7:0							PPSLOCKED
0x1E90	INTPPS	7:0			PORT[1:0]			PIN[2:0]	
0x1E91	T0CKIPPS	7:0			PORT[1:0]			PIN[2:0]	
0x1E92	T1CKIPPS	7:0			PORT[1:0]			PIN[2:0]	
0x1E93	T1GPPS	7:0			PORT[1:0]			PIN[2:0]	
0x1E94	T3CKIPPS	7:0			PORT[1:0]			PIN[2:0]	
0x1E95	T3GPPS	7:0			PORT[1:0]			PIN[2:0]	
0x1E96	T5CKIPPS	7:0			PORT[1:0]			PIN[2:0]	
0x1E97	T5GPPS	7:0			PORT[1:0]			PIN[2:0]	
0x1E98	Reserved								
...									
0x1E9B									
0x1E9C	T2INPPS	7:0			PORT[1:0]			PIN[2:0]	
0x1E9D	T4INPPS	7:0			PORT[1:0]			PIN[2:0]	
0x1E9E	T6INPPS	7:0			PORT[1:0]			PIN[2:0]	
0x1E9F	Reserved								
...									
0x1EA0									
0x1EA1	CCP1PPS	7:0			PORT[1:0]			PIN[2:0]	
0x1EA2	CCP2PPS	7:0			PORT[1:0]			PIN[2:0]	
0x1EA3	CCP3PPS	7:0			PORT[1:0]			PIN[2:0]	
0x1EA4	CCP4PPS	7:0			PORT[1:0]			PIN[2:0]	
0x1EA5	CCP5PPS	7:0			PORT[1:0]			PIN[2:0]	
0x1EA6	Reserved								
...									
0x1EA8									
0x1EA9	SMT1WINPPS	7:0			PORT[1:0]			PIN[2:0]	
0x1EAA	SMT1SIGPPS	7:0			PORT[1:0]			PIN[2:0]	
0x1EAB	SMT2WINPPS	7:0			PORT[1:0]			PIN[2:0]	
0x1EAC	SMT2SIGPPS	7:0			PORT[1:0]			PIN[2:0]	
0x1EAD	Reserved								
...									
0x1EB0									
0x1EB1	CWG1PPS	7:0			PORT[1:0]			PIN[2:0]	
0x1EB2	CWG2PPS	7:0			PORT[1:0]			PIN[2:0]	
0x1EB3	CWG3PPS	7:0			PORT[1:0]			PIN[2:0]	
0x1EB4	Reserved								
...									
0x1EB7									
0x1EB8	MDCARLPPS	7:0			PORT[1:0]			PIN[2:0]	
0x1EB9	MDCARHPPS	7:0			PORT[1:0]			PIN[2:0]	
0x1EBA	MDSRCPPS	7:0			PORT[1:0]			PIN[2:0]	
0x1EBB	CLCIN0PPS	7:0			PORT[1:0]			PIN[2:0]	
0x1EBC	CLCIN1PPS	7:0			PORT[1:0]			PIN[2:0]	
0x1EBD	CLCIN2PPS	7:0			PORT[1:0]			PIN[2:0]	

# PIC16(L)F18455/56

## Register Summary

Address	Name	Bit Pos.									
0x1EBE	CLCIN3PPS	7:0					PORT[1:0]			PIN[2:0]	
0x1EBF	Reserved										
0x1EC2											
0x1EC3	ADACTPPS	7:0					PORT[1:0]			PIN[2:0]	
0x1EC4	Reserved										
0x1EC5	SSP1CLKPPS	7:0					PORT[1:0]			PIN[2:0]	
0x1EC6	SSP1DATPPS	7:0					PORT[1:0]			PIN[2:0]	
0x1EC7	SSP1SSPPS	7:0					PORT[1:0]			PIN[2:0]	
0x1EC8	SSP2CLKPPS	7:0					PORT[1:0]			PIN[2:0]	
0x1EC9	SSP2DATPPS	7:0					PORT[1:0]			PIN[2:0]	
0x1ECA	SSP2SSPPS	7:0					PORT[1:0]			PIN[2:0]	
0x1ECB	RX1PPS	7:0					PORT[1:0]			PIN[2:0]	
0x1ECC	CK1PPS	7:0					PORT[1:0]			PIN[2:0]	
0x1ECD	RX2PPS	7:0					PORT[1:0]			PIN[2:0]	
0x1ECE	CK2PPS	7:0					PORT[1:0]			PIN[2:0]	
0x1ECF	Reserved										
0x1EFF											
0x1F00	INDF0	7:0					INDF0[7:0]				
0x1F01	INDF1	7:0					INDF1[7:0]				
0x1F02	PCL	7:0					PCL[7:0]				
0x1F03	STATUS	7:0					$\overline{TO}$	$\overline{PD}$	Z	DC	C
0x1F04	FSR0	7:0					FSRL[7:0]				
		15:8					FSRH[7:0]				
0x1F06	FSR1	7:0					FSRL[7:0]				
		15:8					FSRH[7:0]				
0x1F08	BSR	7:0					BSR[5:0]				
0x1F09	WREG	7:0					WREG[7:0]				
0x1F0A	PCLATH	7:0					PCLATH[6:0]				
0x1F0B	INTCON	7:0	GIE	PEIE						INTEDG	
0x1F0C	Reserved										
0x1F0F											
0x1F10	RA0PPS	7:0					PPS[5:0]				
0x1F11	RA1PPS	7:0					PPS[5:0]				
0x1F12	RA2PPS	7:0					PPS[5:0]				
0x1F13	RA3PPS	7:0					PPS[5:0]				
0x1F14	RA4PPS	7:0					PPS[5:0]				
0x1F15	RA5PPS	7:0					PPS[5:0]				
0x1F16	RA6PPS	7:0					PPS[5:0]				
0x1F17	RA7PPS	7:0					PPS[5:0]				
0x1F18	RB0PPS	7:0					PPS[5:0]				
0x1F19	RB1PPS	7:0					PPS[5:0]				
0x1F1A	RB2PPS	7:0					PPS[5:0]				
0x1F1B	RB3PPS	7:0					PPS[5:0]				



# PIC16(L)F18455/56

## Register Summary

Address	Name	Bit Pos.									
0x1F1C	RB4PPS	7:0									PPS[5:0]
0x1F1D	RB5PPS	7:0									PPS[5:0]
0x1F1E	RB6PPS	7:0									PPS[5:0]
0x1F1F	RB7PPS	7:0									PPS[5:0]
0x1F20	RC0PPS	7:0									PPS[5:0]
0x1F21	RC1PPS	7:0									PPS[5:0]
0x1F22	RC2PPS	7:0									PPS[5:0]
0x1F23	RC3PPS	7:0									PPS[5:0]
0x1F24	RC4PPS	7:0									PPS[5:0]
0x1F25	RC5PPS	7:0									PPS[5:0]
0x1F26	RC6PPS	7:0									PPS[5:0]
0x1F27	RC7PPS	7:0									PPS[5:0]
0x1F28 ... 0x1F37	Reserved										
0x1F38	ANSELA	7:0	ANSELA7	ANSELA6	ANSELA5	ANSELA4	ANSELA3	ANSELA2	ANSELA1	ANSELA0	
0x1F39	WPUA	7:0	WPUA7	WPUA6	WPUA5	WPUA4	WPUA3	WPUA2	WPUA1	WPUA0	
0x1F3A	ODCONA	7:0	ODCA7	ODCA6	ODCA5	ODCA4	ODCA3	ODCA2	ODCA1	ODCA0	
0x1F3B	SLRCONA	7:0	SLRA7	SLRA6	SLRA5	SLRA4	SLRA3	SLRA2	SLRA1	SLRA0	
0x1F3C	INLVLA	7:0	INLVLA7	INLVLA6	INLVLA5	INLVLA4	INLVLA3	INLVLA2	INLVLA1	INLVLA0	
0x1F3D	IOCAP	7:0	IOCAP7	IOCAP6	IOCAP5	IOCAP4	IOCAP3	IOCAP2	IOCAP1	IOCAP0	
0x1F3E	IOCAN	7:0	IOCAN7	IOCAN6	IOCAN5	IOCAN4	IOCAN3	IOCAN2	IOCAN1	IOCAN0	
0x1F3F	IOCAF	7:0	IOCAF7	IOCAF6	IOCAF5	IOCAF4	IOCAF3	IOCAF2	IOCAF1	IOCAF0	
0x1F40 ... 0x1F42	Reserved										
0x1F43	ANSELB	7:0	ANSELB7	ANSELB6	ANSELB5	ANSELB4	ANSELB3	ANSELB2	ANSELB1	ANSELB0	
0x1F44	WPUB	7:0	WPUB7	WPUB6	WPUB5	WPUB4	WPUB3	WPUB2	WPUB1	WPUB0	
0x1F45	ODCONB	7:0	ODCB7	ODCB6	ODCB5	ODCB4	ODCB3	ODCB2	ODCB1	ODCB0	
0x1F46	SLRCONB	7:0	SLRB7	SLRB6	SLRB5	SLRB4	SLRB3	SLRB2	SLRB1	SLRB0	
0x1F47	INVLB	7:0	INVLB7	INVLB6	INVLB5	INVLB4	INVLB3	INVLB2	INVLB1	INVLB0	
0x1F48	IOCBP	7:0	IOCBP7	IOCBP6	IOCBP5	IOCBP4	IOCBP3	IOCBP2	IOCBP1	IOCBP0	
0x1F49	IOCBN	7:0	IOCBN7	IOCBN6	IOCBN5	IOCBN4	IOCBN3	IOCBN2	IOCBN1	IOCBN0	
0x1F4A	IOCBF	7:0	IOCBF7	IOCBF6	IOCBF5	IOCBF4	IOCBF3	IOCBF2	IOCBF1	IOCBF0	
0x1F4B ... 0x1F4D	Reserved										
0x1F4E	ANSELC	7:0	ANSELC7	ANSELC6	ANSELC5	ANSELC4	ANSELC3	ANSELC2	ANSELC1	ANSELC0	
0x1F4F	WPUC	7:0	WPUC7	WPUC6	WPUC5	WPUC4	WPUC3	WPUC2	WPUC1	WPUC0	
0x1F50	ODCONC	7:0	ODCC7	ODCC6	ODCC5	ODCC4	ODCC3	ODCC2	ODCC1	ODCC0	
0x1F51	SLRCONC	7:0	SLRC7	SLRC6	SLRC5	SLRC4	SLRC3	SLRC2	SLRC1	SLRC0	
0x1F52	INLVLC	7:0	INLVLC7	INLVLC6	INLVLC5	INLVLC4	INLVLC3	INLVLC2	INLVLC1	INLVLC0	
0x1F53	IOCCP	7:0	IOCCP7	IOCCP6	IOCCP5	IOCCP4	IOCCP3	IOCCP2	IOCCP1	IOCCP0	
0x1F54	IOCCN	7:0	IOCCN7	IOCCN6	IOCCN5	IOCCN4	IOCCN3	IOCCN2	IOCCN1	IOCCN0	
0x1F55	IOCCF	7:0	IOCCF7	IOCCF6	IOCCF5	IOCCF4	IOCCF3	IOCCF2	IOCCF1	IOCCF0	
0x1F56	Reserved										

# PIC16(L)F18455/56

## Register Summary

Address	Name	Bit Pos.								
...										
0x1F64										
0x1F65	WPUE	7:0					WPUE3			
0x1F66	Reserved									
...										
0x1F67										
0x1F68	INLVLE	7:0					INLVLE3			
0x1F69	IOCEP	7:0					IOCEP3			
0x1F6A	IOCEN	7:0					IOCEN3			
0x1F6B	IOCEF	7:0					IOCEF3			
0x1F6C	Reserved									
...										
0x1F7F										
0x1F80	INDF0	7:0	INDF0[7:0]							
0x1F81	INDF1	7:0	INDF1[7:0]							
0x1F82	PCL	7:0	PCL[7:0]							
0x1F83	STATUS	7:0				T $\bar{O}$	PD	Z	DC	C
0x1F84	FSR0	7:0	FSRL[7:0]							
		15:8	FSRH[7:0]							
0x1F86	FSR1	7:0	FSRL[7:0]							
		15:8	FSRH[7:0]							
0x1F88	BSR	7:0				BSR[5:0]				
0x1F89	WREG	7:0	WREG[7:0]							
0x1F8A	PCLATH	7:0		PCLATH[6:0]						
0x1F8B	INTCON	7:0	GIE	PEIE						INTEDG
0x1F8C	Reserved									
...										
0x1FE3										
0x1FE4	STATUS_SHAD	7:0				T $\bar{O}$	PD	Z	DC	C
0x1FE5	WREG_SHAD	7:0	WREG[7:0]							
0x1FE6	BSR_SHAD	7:0				BSR[5:0]				
0x1FE7	PCLATH_SHAD	7:0		PCLATH[6:0]						
0x1FE8	FSR0_SHAD	7:0	FSRL[7:0]							
		15:8	FSRH[7:0]							
0x1FEA	FSR1_SHAD	7:0	FSRL[7:0]							
		15:8	FSRH[7:0]							
0x1FEC	Reserved									
0x1FED	STKPTR	7:0				STKPTR[4:0]				
0x1FEE	TOS	7:0	TOSL[7:0]							
		15:8	TOSH[7:0]							

## 39. In-Circuit Serial Programming™ (ICSP™)

ICSP™ programming allows customers to manufacture circuit boards with unprogrammed devices. Programming can be done after the assembly process, allowing the device to be programmed with the most recent firmware or a custom firmware. Five pins are needed for ICSP™ programming:

- ICSPCLK
- ICSPDAT
- $\overline{\text{MCLR}}/\text{V}_{\text{PP}}$
- $\text{V}_{\text{DD}}$
- $\text{V}_{\text{SS}}$

In Program/Verify mode the program memory, User IDs and the Configuration Words are programmed through serial communications. The ICSPDAT pin is a bidirectional I/O used for transferring the serial data and the ICSPCLK pin is the clock input. For more information on ICSP™ refer to the “Memory Programming Specification” (DS40001970).

### 39.1 High-Voltage Programming Entry Mode

The device is placed into High-Voltage Programming Entry mode by holding the ICSPCLK and ICSPDAT pins low then raising the voltage on  $\overline{\text{MCLR}}/\text{V}_{\text{PP}}$  to  $\text{V}_{\text{IH}}$ .

### 39.2 Low-Voltage Programming Entry Mode

The Low-Voltage Programming Entry mode allows the PIC® Flash MCUs to be programmed using  $\text{V}_{\text{DD}}$  only, without high voltage. When the LVP bit of Configuration Words is set to ‘1’, the low-voltage ICSP programming entry is enabled. To disable the Low-Voltage ICSP mode, the LVP bit must be programmed to ‘0’.

Entry into the Low-Voltage Programming Entry mode requires the following steps:

1.  $\overline{\text{MCLR}}$  is brought to  $\text{V}_{\text{IL}}$ .
2. A 32-bit key sequence is presented on ICSPDAT, while clocking ICSPCLK.

Once the key sequence is complete,  $\overline{\text{MCLR}}$  must be held at  $\text{V}_{\text{IL}}$  for as long as Program/Verify mode is to be maintained.

If low-voltage programming is enabled ( $\text{LVP} = 1$ ), the  $\overline{\text{MCLR}}$  Reset function is automatically enabled and cannot be disabled. See the  $\overline{\text{MCLR}}$  Section for more information.

The LVP bit can only be reprogrammed to ‘0’ by using the High-Voltage Programming mode.

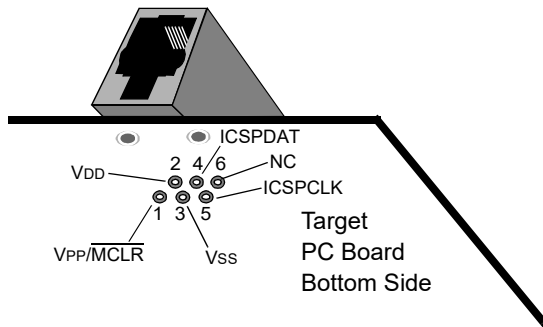
#### Related Links

[8.4 MCLR Reset](#)

### 39.3 Common Programming Interfaces

Connection to a target device is typically done through an ICSP™ header. A commonly found connector on development tools is the RJ-11 in the 6P6C (6-pin, 6-connector) configuration. See [Figure 39-1](#).

**Figure 39-1. ICD RJ-11 Style Connector Interface**



**Pin Description\***

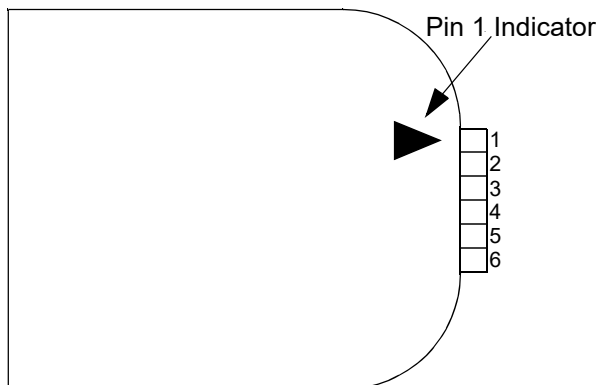
- 1 =  $V_{PP}/\overline{MCLR}$
- 2 =  $V_{DD}$  Target
- 3 =  $V_{SS}$  (ground)
- 4 = ICSPDAT
- 5 = ICSPCLK
- 6 = No Connect

Another connector often found in use with the PICkit™ programmers is a standard 6-pin header with 0.1 inch spacing. Refer to [Figure 39-2](#).

For additional interface recommendations, refer to the specific device programmer manual prior to PCB design.

It is recommended that isolation devices be used to separate the programming pins from other circuitry. The type of isolation is highly dependent on the specific application and may include devices such as resistors, diodes, or even jumpers. See [Figure 39-3](#) for more information.

**Figure 39-2. PICkit™ Programmer Style Connector Interface**



**Pin Description<sup>1</sup>**

- 1 =  $V_{PP}/\overline{MCLR}$
- 2 =  $V_{DD}$  Target
- 3 =  $V_{SS}$  (ground)
- 4 = ICSPDAT

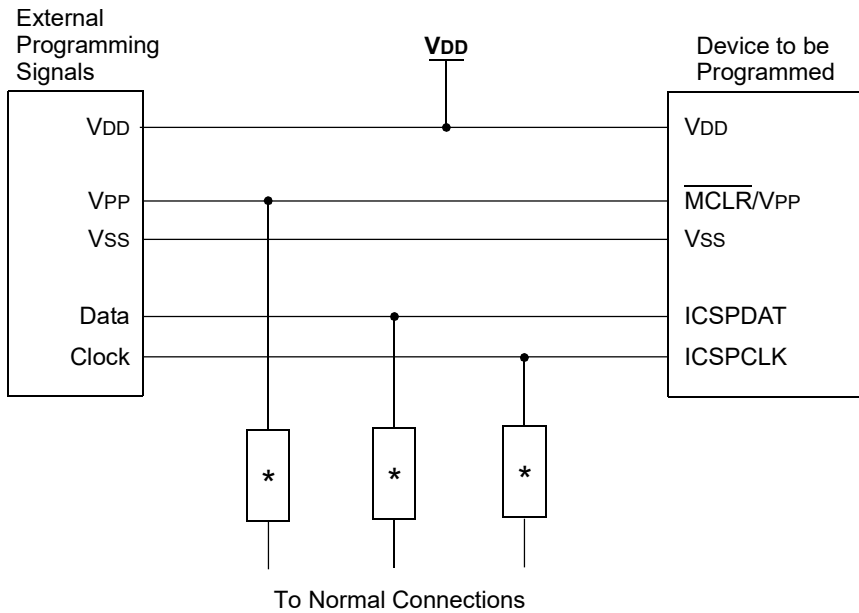
5 = ICSPCLK

6 = No Connect

**Note:**

- Note:** The 6-pin header (0.100" spacing) accepts 0.025" square pins.

**Figure 39-3. Typical Connection for ICSP™ Programming**



\* Isolation devices (as required).

## 40. Instruction Set Summary

PIC16(L)F18455/56 devices incorporate the standard set of 50 PIC16 core instructions. Each instruction is a 14-bit word containing the operation code (opcode) and all required operands. The opcodes are broken into three broad categories:

- Byte Oriented
- Bit Oriented
- Literal and Control

The literal and control category contains the most varied instruction word format.

The [Instruction Set](#) table lists the instructions recognized by the MPASM™ assembler.

All instructions are executed within a single instruction cycle, with the following exceptions, which may take two or three cycles:

- Subroutine entry takes two cycles (CALL, CALLW)
- Returns from interrupts or subroutines take two cycles (RETURN, RETLW, RETFIE)
- Program branching takes two cycles (GOTO, BRA, BRW, BTFSS, BTFSC, DECFSZ, INCSFZ)
- One additional instruction cycle will be used when any instruction references an indirect file register and the file select register is pointing to program memory.

One instruction cycle consists of 4 oscillator cycles; for an oscillator frequency of 4 MHz, this gives a nominal instruction execution rate of 1 MHz.

All instruction examples use the format '0xhh' to represent a hexadecimal number, where 'h' signifies a hexadecimal digit.

### 40.1 Read-Modify-Write Operations

Any WRITE instruction that specifies a file register as part of the instruction performs a Read-Modify-Write (R-M-W) operation. The register is read, the data is modified, and the result is stored according to either the working (W) register, or the originating file register, depending on the state of the destination designator 'd' (see the table below for more information). A read operation is performed on a register even if the instruction writes to that register.

**Table 40-1. Opcode Field Descriptions**

Field	Description
f	Register file address (0x00 to 0x7F)
W	Working register (accumulator)
b	Bit address within an 8-bit file register
k	Literal field, constant data or label
x	Don't care location (= 0 or 1). The assembler will generate code with x = 0. It is the recommended form of use for compatibility with all Microchip software tools.
d	Destination select; d = 0: store result in W, d = 1: store result in file register f.

Field	Description
n	FSR or INDF number. (0-1)
mm	Prepost increment-decrement mode selection

**Table 40-2. Abbreviation Descriptions**

Field	Description
PC	Program Counter
$\overline{TO}$	Time-Out bit
C	Carry bit
DC	Digit Carry bit
Z	Zero bit
$\overline{PD}$	Power-Down bit

## 40.2 Standard Instruction Set

**Table 40-3. Instruction Set**

Mnemonic, Operands	Description	Cycles	14-Bit Opcode				Status Affected	Notes	
			MSb			LSb			
<b>BYTE-ORIENTED OPERATIONS</b>									
ADDWF	f, d	Add WREG and f	1	00	0111	dfff	ffff	C, DC, Z	2
ADDWFC	f, d	Add WREG and CARRY bit to f	1	11	1101	dfff	ffff	C, DC, Z	2
ANDWF	f, d	AND WREG with f	1	00	0101	dfff	ffff	Z	2
ASRF	f, d	Arithmetic Right Shift	1	11	0111	dfff	ffff	C, Z	2
LSLF	f, d	Logical Left Shift	1	11	0101	dfff	ffff	C, Z	2
LSRF	f, d	Logical Right Shift	1	11	0110	dfff	ffff	C, Z	2
CLRF	f	Clear f	1	00	0001	1fff	ffff	Z	2
CLRW	–	Clear WREG	1	00	0001	0000	00xx	Z	
COMF	f, d	Complement f	1	00	1001	dfff	ffff	Z	2
DECF	f, d	Decrement f	1	00	0011	dfff	ffff	Z	2
INCF	f, d	Increment f	1	00	1010	dfff	ffff	Z	2

# PIC16(L)F18455/56

## Instruction Set Summary

Mnemonic, Operands		Description	Cycles	14-Bit Opcode				Status Affected	Notes
				MSb			LSb		
IORWF	f, d	Inclusive OR WREG with f	1	00	0100	dfff	ffff	Z	2
MOVF	f, d	Move f	1	00	1000	dfff	ffff	Z	2
MOVWF	f	Move WREG to f	1	00	0000	1fff	ffff	None	2
RLF	f, d	Rotate Left f through Carry	1	00	1101	dfff	ffff	C	2
RRF	f, d	Rotate Right f through Carry	1	00	1100	dfff	ffff	C	2
SUBWF	f, d	Subtract WREG from f	1	00	0010	dfff	ffff	C, DC, Z	2
SUBWFB	f, d	Subtract WREG from f with borrow	1	11	1011	dfff	ffff	C, DC, Z	2
SWAPF	f, d	Swap nibbles in f	1	00	1110	dfff	ffff	None	2
XORWF	f, d	Exclusive OR WREG with f	1	00	0110	dfff	ffff	Z	2
<b>BYTE ORIENTED SKIP OPERATIONS</b>									
DECFSZ	f, d	Decrement f, Skip if 0	1(2)	00	1011	dfff	ffff	None	1, 2
INCFSSZ	f, d	Increment f, Skip if 0	1(2)	00	1111	dfff	ffff	None	1, 2
<b>BIT-ORIENTED FILE REGISTER OPERATIONS</b>									
BCF	f, b	Bit Clear f	1	01	00bb	bfff	ffff	None	2
BSF	f, b	Bit Set f	1	01	01bb	bfff	ffff	None	2
<b>BIT-ORIENTED SKIP OPERATIONS</b>									
BTFSC	f, b	Bit Test f, Skip if Clear	1(2)	01	10bb	bfff	ffff	None	1, 2
BTFSS	f, b	Bit Test f, Skip if Set	1(2)	1010	11bb	bfff	ffff	None	1, 2
<b>LITERAL OPERATIONS</b>									
ADDLW	k	Add literal and WREG	1	11	1110	kkkk	kkkk	C, DC, Z	
ANDLW	k	AND literal with WREG	1	11	1001	kkkk	kkkk	Z	
IORLW	k	Inclusive OR literal with WREG	1	11	1000	kkkk	kkkk	Z	
MOVLB	k	Move literal to BSR	1	00	000	0k	kkkk	None	
MOVLP	k	Move literal to PCLATH	1	11	0001	1kkk	kkkk	None	



# PIC16(L)F18455/56

## Instruction Set Summary

Mnemonic, Operands		Description	Cycles	14-Bit Opcode				Status Affected	Notes
				MSb			LSb		
MOVLW	k	Move literal to W	1	11	0000	kkkk	kkkk	None	
SUBLW	k	Subtract W from literal	1	11	1100	kkkk	kkkk	C, DC, Z	
XORLW	k	Exclusive OR literal with W	1	11	1010	kkkk	kkkk	Z	
<b>CONTROL OPERATIONS</b>									
BRA	k	Relative Branch	2	11	001k	kkkk	kkkk	None	
BRW	—	Relative Branch with WREG	2	00	0000	0000	1011	None	
CALL	k	Call Subroutine	2	10	0kkk	kkkk	kkkk	None	
CALLW	—	Call Subroutine with WREG	2	00	0000	0000	1010	None	
GOTO	k	Go to address	2	10	1kkk	kkkk	kkkk	None	
RETFIE	k	Return from interrupt	2	00	0000	0000	1001	None	
RETLW	k	Return with literal in WREG	2	11	0100	kkkk	kkkk	None	
RETURN	—	Return from Subroutine	2	00	0000	0000	1000	None	
<b>INHERENT OPERATIONS</b>									
CLRWDT	—	Clear Watchdog Timer	1	00	0000	0110	0100	$\overline{TO}$ , $\overline{PD}$	
NOP	—	No Operation	1	00	0000	0000	0000	None	
RESET	—	Software device Reset	1	00	0000	0000	0001	None	
SLEEP	—	Go into Standby or Idle mode	1	00	0000	0110	0011	$\overline{TO}$ , $\overline{PD}$	
TRIS	f	Load TRIS register with WREG	1	00	0000	0110	0fff	None	
<b>C-COMPILER OPTIMIZED</b>									
ADDFSR	n, k	Add Literal k to FSRn	1	11	0001	0nkk	kkkk	None	
MOVIW	n, mm	Move Indirect FSRn to WREG with pre/post inc/dec modifier, mm	1	00	0000	0001	0nmm	Z	2, 3
	k[n]	Move INDFn to WREG, Indexed Indirect.	1	11	1111	0nkk	kkkk	Z	2
MOVWI	n, mm	Move WREG to Indirect FSRn with pre/post inc/dec modifier, mm	1	00	0000	0001	1nmm	None	2, 3
	k[n]	Move WREG to INDFn, Indexed Indirect.	1	11	1111	1nkk	kkkk	None	2

**Note:**

1. If the Program Counter (PC) is modified, or a conditional test is true, the instruction requires two cycles. The second cycle is executed as a NOP.
2. If this instruction addresses an INDF register and the MSb of the corresponding FSR is set, this instruction will require one additional instruction cycle.
3. Details on MOVW and MOVWI instruction descriptions are available in the next section.

**40.2.1 Standard Instruction Set**

<b>ADDFSR</b>	<b>Add Literal to FSRn</b>
Syntax:	[ <i>label</i> ] ADDFSR FSRn, k
Operands:	-32 ≤ k ≤ 31; n ∈ [ 0, 1]
Operation:	FSR(n) + k → FSR(n)
Status Affected:	None
Description:	The signed 6-bit literal 'k' is added to the contents of the FSRnH:FSRnL register pair. FSRn is limited to the range 0000h-FFFFh. Moving beyond these bounds will cause the FSR to wrap-around.

<b>ADDLW</b>	<b>ADD literal to W</b>
Syntax:	[ <i>label</i> ] ADDLW k
Operands:	0 ≤ k ≤ 255
Operation:	(W) + k → (W)
Status Affected:	C, DC, Z
Description:	The contents of W are added to the 8-bit literal 'k' and the result is placed in W.

<b>ADDWF</b>	<b>ADD W to f</b>
Syntax:	[ <i>label</i> ] ADDWF f, d
Operands:	0 ≤ f ≤ 127 d ∈ [0,1]
Operation:	(W) + (f) → dest
Status Affected:	C, DC, Z
Description:	Add the contents of the W register with register 'f'. If 'd' is '0', the result is stored in the W register. If 'd' is '1', the result is stored back in register 'f'.

ADDWFC	ADD W and CARRY bit to f
Syntax:	[ <i>label</i> ] ADDWFC f {,d}
Operands:	0 ≤ f ≤ 127 d ∈ [0,1]
Operation:	(W) + (f) + (C) → dest
Status Affected:	C, DC, Z
Description:	Add W, the Carry flag and data memory location 'f'. If 'd' is '0', the result is placed in W. If 'd' is '1', the result is placed in data memory location 'f'.

ANDLW	AND literal with W
Syntax:	[ <i>label</i> ] ANDLW k
Operands:	0 ≤ k ≤ 255
Operation:	(W) .AND. k → (W)
Status Affected:	Z
Description:	The contents of W are AND'ed with the 8-bit literal 'k'. The result is placed in W.

ANDWF	AND W with f
Syntax:	[ <i>label</i> ] ANDWF f, d
Operands:	0 ≤ f ≤ 127 d ∈ [0,1]
Operation:	(W) .AND. (f) → dest
Status Affected:	Z
Description:	AND the W register with register 'f'. If 'd' is '0', the result is stored in the W register. If 'd' is '1', the result is stored back in register 'f'.

ASRF	Arithmetic Right Shift
Syntax:	[ <i>label</i> ] ASRF f, d
Operands:	0 ≤ f ≤ 127 d ∈ [0,1]
Operation:	(f<7>) → dest<7> (f<7:1>) → dest<6:0> (f<0>) → C

ASRF	Arithmetic Right Shift
Status Affected:	C, Z
Description:	<p>The contents of register 'f' are shifted one bit to the right through the Carry flag. The MSb remains unchanged.</p> <p>If 'd' is '0', the result is placed in W.</p> <p>If 'd' is '1', the result is stored back in register 'f'.</p> <p><b>Register f → C</b></p>

BCF	Bit Clear f
Syntax:	[ <i>label</i> ] BCF f, b
Operands:	$0 \leq f \leq 127$ $0 \leq b \leq 7$
Operation:	$0 \rightarrow f \langle b \rangle$
Status Affected:	None
Description:	Bit 'b' in register 'f' is cleared.

BRA	Relative Branch
Syntax:	[ <i>label</i> ] BRA <i>label</i> [ <i>label</i> ] BRA \$+k
Operands:	$-256 \leq \text{label} - \text{PC} + 1 \leq 255$ $-256 \leq k \leq 255$
Operation:	$(\text{PC}) + 1 + k \rightarrow \text{PC}$
Status Affected:	None
Description:	<p>Add the signed 9-bit literal 'k' to the PC.</p> <p>Since the PC will have incremented to fetch the next instruction, the new address will be <math>\text{PC} + 1 + k</math>.</p> <p>This instruction is a 2-cycle instruction. This branch has a limited range.</p>

BRW	Relative Branch with W
Syntax:	[ <i>label</i> ] BRW
Operands:	None
Operation:	$(\text{PC}) + (W) \rightarrow \text{PC}$

<b>BRW</b>	<b>Relative Branch with W</b>
Status Affected:	None
Description:	Add the contents of W (unsigned) to the PC. Since the PC will have incremented to fetch the next instruction, the new address will be PC + 1 + (W). This instruction is a 2-cycle instruction.

<b>BSF</b>	<b>Bit Set f</b>
Syntax:	[ <i>label</i> ] BSF f, b
Operands:	0 ≤ f ≤ 127 0 ≤ b ≤ 7
Operation:	1 → (f<b>)
Status Affected:	None
Description:	Bit 'b' in register 'f' is set.

<b>BTFSC</b>	<b>Bit Test File, Skip if Clear</b>
Syntax:	[ <i>label</i> ] BTFSC f, b
Operands:	0 ≤ f ≤ 127 0 ≤ b ≤ 7
Operation:	skip if (f<b>) = 0
Status Affected:	None
Description:	If bit 'b' in register 'f' is '1', the next instruction is executed. If bit 'b', in register 'f', is '0', the next instruction is discarded, and a NOP is executed instead, making this a 2-cycle instruction.

<b>BTFSS</b>	<b>Bit Test File, Skip if Set</b>
Syntax:	[ <i>label</i> ] BTFSS f, b
Operands:	0 ≤ f ≤ 127 0 ≤ b < 7
Operation:	skip if (f<b>) = 1
Status Affected:	None
Description:	If bit 'b' in register 'f' is '0', the next instruction is executed. If bit 'b' is '1', then the next instruction is discarded, and a NOP is executed instead, making this a 2-cycle instruction.

# PIC16(L)F18455/56

## Instruction Set Summary

CALL	Subroutine Call
Syntax:	[ <i>label</i> ] CALL k
Operands:	$0 \leq k \leq 2047$
Operation:	(PC) + 1 → TOS, k → PC<10:0>, (PCLATH<6:3>) → PC<14:11>
Status Affected:	None
Description:	Call Subroutine. First, return address (PC + 1) is pushed onto the stack. The 11-bit immediate address is loaded into PC bits <10:0>. The upper bits of the PC are loaded from PCLATH. CALL is a 2-cycle instruction.

CALLW	Subroutine Call with W
Syntax:	[ <i>label</i> ] CALLW
Operands:	None
Operation:	(PC) + 1 → TOS, (W) → PC<7:0>, (PCLATH<6:0>) → PC<14:8>
Status Affected:	None
Description:	Subroutine call with W. First, the return address (PC + 1) is pushed onto the return stack. Then, the contents of W is loaded into PC<7:0>, and the contents of PCLATH into PC<14:8>. CALLW is a 2-cycle instruction.

CLRF	Clear f
Syntax:	[ <i>label</i> ] CLRF f
Operands:	$0 \leq f \leq 127$
Operation:	000h → f 1 → Z
Status Affected:	Z
Description:	The contents of register 'f' are cleared and the Z bit is set.

<b>CLRW</b>	<b>Clear W</b>
Syntax:	[ <i>label</i> ] CLRW
Operands:	None
Operation:	00h → (W) 1 → Z
Status Affected:	Z
Description:	W register is cleared. Zero bit (Z) is set.

<b>CLRWDT</b>	<b>Clear Watchdog Timer</b>
Syntax:	[ <i>label</i> ] CLRWDT
Operands:	None
Operation:	00h → WDT, 00h → WDT prescaler, 1 → $\overline{TO}$ , 1 → $\overline{PD}$
Status Affected:	$\overline{TO}$ , $\overline{PD}$
Description:	CLRWDT instruction resets the Watchdog Timer. It also resets the prescaler of the WDT. Status bits, $\overline{TO}$ and $\overline{PD}$ , are set.

<b>COMF</b>	<b>Complement f</b>
Syntax:	[ <i>label</i> ] COMF f, d
Operands:	$0 \leq f \leq 127$ $d \in [0,1]$
Operation:	$(\bar{f}) \rightarrow \text{dest}$
Status Affected:	Z
Description:	The contents of register 'f' are complemented. If 'd' is '0', the result is stored in W. If 'd' is '1', the result is stored back in register 'f'.

<b>DECF</b>	<b>Decrement f</b>
Syntax:	[ <i>label</i> ] DECF f, d
Operands:	$0 \leq f \leq 127$ $d \in [0,1]$
Operation:	$(f) - 1 \rightarrow \text{dest}$

<b>DECF</b>	<b>Decrement f</b>
Status Affected:	Z
Description:	Decrement register 'f'. If 'd' is '0', the result is stored in the W register. If 'd' is '1', the result is stored back in register 'f'.

<b>DECFSZ</b>	<b>Decrement f, skip if 0</b>
Syntax:	[ <i>label</i> ] DECFSZ f, d
Operands:	$0 \leq f \leq 127$ $d \in [0,1]$
Operation:	$(f) - 1 \rightarrow \text{dest}$ , skip if result = 0
Description:	The contents of register 'f' are decremented. If 'd' is '0', the result is placed in the W register. If 'd' is '1', the result is placed back in register 'f'. If the result is '1', the next instruction is executed. If the result is '0', then a NOP is executed instead, making it a 2-cycle instruction.

<b>GOTO</b>	<b>Unconditional Branch</b>
Syntax:	[ <i>label</i> ] GOTO k
Operands:	$0 \leq k \leq 2047$
Operation:	$k \rightarrow \text{PC}\langle 10:0 \rangle$ $\text{PCLATH}\langle 6:3 \rangle \rightarrow \text{PC}\langle 14:11 \rangle$
Status Affected:	None
Description:	GOTO is an unconditional branch. The 11-bit immediate value is loaded into PC bits <10:0>. The upper bits of PC are loaded from PCLATH<4:3>. GOTO is a 2-cycle instruction.

<b>INCF</b>	<b>Increment f</b>
Syntax:	[ <i>label</i> ] INCF f, d
Operands:	$0 \leq f \leq 127$ $d \in [0,1]$
Operation:	$(f) + 1 \rightarrow \text{dest}$



# PIC16(L)F18455/56

## Instruction Set Summary

<b>INCF</b>	<b>Increment f</b>
Status Affected:	Z
Description:	The contents of register 'f' are incremented. If 'd' is '0', the result is placed in the W register. If 'd' is '1', the result is placed back in register 'f'.

<b>INCFSZ</b>	<b>Increment f, skip if 0</b>
Syntax:	[ <i>label</i> ] INCFSZ f, d
Operands:	$0 \leq f \leq 127$ $d \in [0,1]$
Operation:	$(f) + 1 \rightarrow \text{dest}$ , skip if result = 0
Status Affected:	None
Description:	The contents of register 'f' are incremented. If 'd' is '0', the result is placed in the W register. If 'd' is '1', the result is placed back in register 'f'. If the result is '1', the next instruction is executed. If the result is '0', a NOP is executed instead, making it a 2-cycle instruction.

<b>IORLW</b>	<b>Inclusive OR literal with W</b>
Syntax:	[ <i>label</i> ] IORLW k
Operands:	$0 \leq k \leq 255$
Operation:	$(W) .OR. k \rightarrow (W)$
Status Affected:	Z
Description:	The contents of W are ORed with the 8-bit literal 'k'. The result is placed in W.

<b>IORWF</b>	<b>Inclusive OR W with f</b>
Syntax:	IORWF f, d
Operands:	$0 \leq f \leq 127$ $d \in [0,1]$
Operation:	$(W) .OR. (f) \rightarrow \text{dest}$

<b>IORWF</b>	<b>Inclusive OR W with f</b>
Status Affected:	Z
Description:	Inclusive OR the W register with register 'f'. If 'd' is '0', the result is placed in the W register. If 'd' is '1', the result is placed back in register 'f'.

<b>LSLF</b>	<b>Logical Left Shift</b>
Syntax:	[ <i>label</i> ] LSLF f {,d}
Operands:	$0 \leq f \leq 127$ $d \in [0,1]$
Operation:	$(f<7>) \rightarrow C$ $(f<6:0>) \rightarrow \text{dest}<7:1>$ $0 \rightarrow \text{dest}<0>$
Status Affected:	C, Z
Description:	The contents of register 'f' are shifted one bit to the left through the Carry flag. A '0' is shifted into the LSb. If 'd' is '0', the result is placed in W. If 'd' is '1', the result is stored back in register 'f'.  <b>C ← Register f ← 0</b>

<b>LSRF</b>	<b>Logical Right Shift</b>
Syntax:	[ <i>label</i> ] LSRF f {,d}
Operands:	$0 \leq f \leq 127$ $d \in [0,1]$
Operation:	$0 \rightarrow \text{dest}<7>$ $(f<7:1>) \rightarrow \text{dest}<6:0>$ , $(f<0>) \rightarrow C$
Status Affected:	C, Z
Description:	The contents of register 'f' are shifted one bit to the right through the Carry flag. A '0' is shifted into the MSb. If 'd' is '0', the result is placed in W. If 'd' is '1', the result is stored back in register 'f'.  <b>0 → register f → C</b>

<b>MOVF</b>	<b>Move f</b>
Syntax:	[ <i>label</i> ] MOVF f, d
Operands:	0 ≤ f ≤ 127 d ∈ [0,1]
Operation:	f → dest
Status Affected:	Z
Description:	The contents of register f is moved to a destination dependent upon the status of d. If d = 0, destination is W register. If d = 1, the destination is file register f itself. d = 1 is useful to test a file register since status flag Z is affected.
Words:	1
Cycles:	1

Example:	MOVF FSR, 0
After Instruction W = value in FSR register Z = 1	

<b>MOVIW</b>	<b>Move INDF<sub>n</sub> to W</b>
Syntax:	[ <i>label</i> ] MOVIW ++FSR <sub>n</sub> [ <i>label</i> ] MOVIW --FSR <sub>n</sub> [ <i>label</i> ] MOVIW FSR <sub>n</sub> ++ [ <i>label</i> ] MOVIW FSR <sub>n</sub> -- [ <i>label</i> ] MOVIW k[FSR <sub>n</sub> ]
Operands:	n ∈ [0,1] mm ∈ [00,01,10,11] -32 ≤ k ≤ 31
Operation:	INDF <sub>n</sub> → (W) Effective address is determined by <ul style="list-style-type: none"> <li>FSR + 1 (preincrement)</li> <li>FSR - 1 (predecrement)</li> <li>FSR + k (relative offset)</li> </ul> After the Move, the FSR value will be either: <ul style="list-style-type: none"> <li>FSR + 1 (all increments)</li> <li>FSR - 1 (all decrements)</li> <li>Unchanged</li> </ul>

<b>MOVIW</b>	<b>Move INDFn to W</b>		
	Z		
	<b>MODE</b>	<b>SYNTAX</b>	<b>mm</b>
Status Affected:	Preincrement	++FSRn	00
	Predecrement	--FSRn	01
	Postincrement	FSRn++	10
	Postdecrement	FSRn--	11
Description:	<p>This instruction is used to move data between W and one of the indirect registers (INDFn).</p> <p>Before/after this move, the pointer (FSRn) is updated by pre/post incrementing/ decrementing it.</p> <p>The INDFn registers are not physical registers.</p> <p>Any instruction that accesses an INDFn register actually accesses the register at the address specified by the FSRn.</p> <p>FSRn is limited to the range 0000h - FFFFh.</p> <p>Incrementing/decrementing it beyond these bounds will cause it to wrap-around.</p>		

<b>MOVLB</b>	<b>Move literal to BSR</b>
Syntax:	[ <i>label</i> ] MOVLB k
Operands:	$0 \leq k \leq 127$
Operation:	$k \rightarrow \text{BSR}$
Status Affected:	None
Description:	The 6-bit literal 'k' is loaded into the Bank Select Register (BSR).

<b>MOVLP</b>	<b>Move literal to PCLATH</b>
Syntax:	[ <i>label</i> ] MOVLP k
Operands:	$0 \leq k \leq 127$
Operation:	$k \rightarrow \text{PCLATH}$
Status Affected:	None
Description:	The 7-bit literal 'k' is loaded into the PCLATH register.

<b>MOVLW</b>	<b>Move literal to W</b>
Syntax:	[ <i>label</i> ] MOVLW k
Operands:	$0 \leq k \leq 255$
Operation:	$k \rightarrow (W)$
Status Affected:	None

<b>MOVLW</b>	<b>Move literal to W</b>			
Description:	The 8-bit literal 'k' is loaded into W register. The "don't cares" will assemble as '0's.			
Words:	1			
Cycles:	1			

Example:	MOVLW	5Ah
After Instruction W = 5Ah		

<b>MOVWF</b>	<b>Move W to f</b>			
Syntax:	[ <i>label</i> ] MOVWF f			
Operands:	0 ≤ f ≤ 127			
Operation:	(W) → f			
Status Affected:	None			
Description:	Move data from W to register 'f'.			
Words:	1			
Cycles:	1			

Example:	MOVWF	LATA
Before Instruction LATA = FFh W = 4Fh After Instruction LATA = 4Fh W = 4Fh		

<b>MOVWI</b>	<b>Move W to INDFn</b>			
Syntax:	[ <i>label</i> ] MOVWI ++FSRn [ <i>label</i> ] MOVWI --FSRn [ <i>label</i> ] MOVWI FSRn++ [ <i>label</i> ] MOVWI FSRn-- [ <i>label</i> ] MOVWI k[FSRn]			
Operands:	n ∈ [0,1] mm ∈ [00,01,10,11]			

MOVWI	Move W to INDFn		
	-32 ≤ k ≤ 31		
Operation:	(W) → INDFn Effective address is determined by <ul style="list-style-type: none"> <li>• FSR + 1 (preincrement)</li> <li>• FSR - 1 (predecrement)</li> <li>• FSR + k (relative offset)</li> </ul> After the Move, the FSR value will be either: <ul style="list-style-type: none"> <li>• FSR + 1 (all increments)</li> <li>• FSR - 1 (all decrements)</li> <li>• Unchanged</li> </ul>		
Status Affected:	None		
	MODE	SYNTAX	mm
	Preincrement	++FSRn	00
	Predecrement	--FSRn	01
	Postincrement	FSRn++	10
Postdecrement	FSRn--	11	
Description:	This instruction is used to move data between W and one of the indirect registers (INDFn). Before/after this move, the pointer (FSRn) is updated by pre/post incrementing/ decrementing it. The INDFn registers are not physical registers. Any instruction that accesses an INDFn register actually accesses the register at the address specified by the FSRn. FSRn is limited to the range 0000h-FFFFh. Incrementing/decrementing it beyond these bounds will cause it to wrap-around. The increment/decrement operation on FSRn WILL NOT affect any Status bits.		

NOP	No Operation			
Syntax:	[ <i>label</i> ] NOP			
Operands:	None			
Operation:	No operation			
Status Affected:	None			
Description:	No operation.			
Words:	1			
Cycles:	1			

# PIC16(L)F18455/56

## Instruction Set Summary

Example:	NOP
None.	

RESET	Software Reset
Syntax:	[ <i>label</i> ] RESET
Operands:	None
Operation:	Execute a device Reset. Resets the $\overline{RI}$ flag of the PCON register.
Status Affected:	None
Description:	This instruction provides a way to execute a hardware Reset by software.

RETFIE	Return from Interrupt
Syntax:	[ <i>label</i> ] RETFIE k
Operands:	None
Operation:	(TOS) → PC, 1 → GIE
Status Affected:	None
Description:	Return from Interrupt. Stack is POPed and Top-of-Stack (TOS) is loaded in the PC. Interrupts are enabled by setting Global Interrupt Enable bit, GIE (INTCON<7>). This is a 2-cycle instruction.
Words:	1
Cycles:	2

Example:	RETFIE
After Interrupt PC = TOS GIE = 1	

RETLW	Return literal to W
Syntax:	[ <i>label</i> ] RETLW k
Operands:	$0 \leq k \leq 255$
Operation:	k → (W), (TOS) → PC,
Status Affected:	None

<b>RETLW</b>	<b>Return literal to W</b>			
Description:	The W register is loaded with the 8-bit literal 'k'. The program counter is loaded from the top of the stack (the return address). This is a 2-cycle instruction.			
Words:	1			
Cycles:	2			

<b>Example:</b>				
<pre> CALL TABLE          ; W contains table ; offset value ; W now has ; table value : TABLE ADDWF PC             ; W = offset RETLW k1             ; Begin table RETLW k2             ; : : RETLW kn             ; End of table </pre>				
<b>Before Instruction</b> W = 07h  <b>After Instruction</b> W = value of k8				

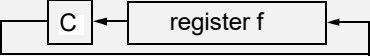
<b>RETURN</b>	<b>Return from Subroutine</b>			
Syntax:	[ <i>label</i> ] RETURN			
Operands:	None			
Operation:	(TOS) → PC,			
Status Affected:	None			
Encoding:	0000	0000	0001	001s
Description:	Return from subroutine. The stack is POPped and the top of the stack (TOS) is loaded into the Program Counter. This is a 2-cycle instruction.			

<b>RLF</b>	<b>Rotate Left f through Carry</b>			
Syntax:	[ <i>label</i> ] RLF f, d			
Operands:	0 ≤ f ≤ 127 d ∈ [0,1]			
Operation:	(f<n>) → dest<n + 1>, (f<7>) → C,			




# PIC16(L)F18455/56

## Instruction Set Summary

RLF	Rotate Left f through Carry			
	(C) → dest<0>			
Status Affected:	C			
Encoding:	0011	01da	fff	fff
Description:	<p>The contents of register 'f' are rotated one bit to the left through the CARRY flag. If 'd' is '0', the result is placed in W. If 'd' is '1', the result is stored back in register 'f' (default).</p> 			
Words:	1			
Cycles:	1			

Example:	RLF	REG1, 0
<p>Before Instruction REG1 = 1110 0110 C = 0</p> <p>After Instruction REG = 1110 0110 W = 1100 1100 C = 1</p>		

RRF	Rotate Right f through Carry
Syntax:	[ label ] RRF f, d
Operands:	$0 \leq f \leq 127$ $d \in [0,1]$
Operation:	$(f\langle n \rangle) \rightarrow \text{dest}\langle n - 1 \rangle,$ $(f\langle 0 \rangle) \rightarrow C,$ $(C) \rightarrow \text{dest}\langle 7 \rangle$
Status Affected:	C
Description:	<p>The contents of register 'f' are rotated one bit to the right through the CARRY flag. If 'd' is '0', the result is placed in W. If 'd' is '1', the result is placed back in register 'f' (default).</p> 

<b>SLEEP</b>	<b>Enter Sleep mode</b>
Syntax:	[ <i>label</i> ] SLEEP
Operands:	None
Operation:	00h → WDT, 0 → WDT prescaler, 1 → $\overline{TO}$ , 0 → $\overline{PD}$
Status Affected:	$\overline{TO}$ , $\overline{PD}$
Description:	The Power-down Status bit ( $\overline{PD}$ ) is cleared. The Time-out Status bit ( $\overline{TO}$ ) is set. Watchdog Timer and its prescaler are cleared.

<b>SUBLW</b>	<b>Subtract W from literal</b>
Syntax:	[ <i>label</i> ] SUBLW k
Operands:	$0 \leq k \leq 255$
Operation:	$k - (W) \rightarrow (W)$
Status Affected:	C, DC, Z
Description:	The W register is subtracted (2's complement method) from the 8-bit literal 'k'. The result is placed in the W register. C = 0, $W > k$ C = 1, $W \leq k$ DC = 0, $W[3:0] > k[3:0]$ DC = 1, $W[3:0] \leq k[3:0]$

<b>SUBWF</b>	<b>Subtract W from f</b>
Syntax:	[ <i>label</i> ] SUBWF f, d
Operands:	$0 \leq f \leq 127$ $d \in [0,1]$
Operation:	$(f) - (W) \rightarrow (\text{dest})$
Status Affected:	C, DC, Z
Description:	Subtract (2's complement method) W register from register 'f'. If 'd' is '0', the result is stored in the W register. If 'd' is '1', the result is stored back in register 'f'. C = 0, $W > f$

<b>SUBWF</b>	<b>Subtract W from f</b>
	$C = 1, W \leq f$ $DC = 0, W[3:0] > f[3:0]$ $DC = 1, W[3:0] \leq f[3:0]$

<b>SUBFWB</b>	<b>Subtract W from f with Borrow</b>
Syntax:	[ <i>label</i> ] SUBFWB f {,d}
Operands:	$0 \leq f \leq 127$ $d \in [0,1]$
Operation:	$(W) - (f) - (\overline{B}) \rightarrow \text{dest}$
Status Affected:	C, DC, Z
Description:	Subtract W and the BORROW flag (CARRY) from register 'f' (2's complement method). If 'd' is '0', the result is stored in W. If 'd' is '1', the result is stored back in register 'f'.

<b>SWAPF</b>	<b>Swap Nibbles in f</b>
Syntax:	[ <i>label</i> ] SWAPF f, d
Operands:	$0 \leq f \leq 127$ $d \in [0,1]$
Operation:	$(f<3:0>) \rightarrow \text{dest}<7:4>$ , $(f<7:4>) \rightarrow \text{dest}<3:0>$
Status Affected:	None
Description:	The upper and lower nibbles of register 'f' are exchanged. If 'd' is '0', the result is placed in W. If 'd' is '1', the result is placed in register 'f' (default).

<b>TRIS</b>	<b>Load TRIS Register with W</b>
Syntax:	[ <i>label</i> ] TRIS f
Operands:	$5 \leq f \leq 7$
Operation:	$(W) \rightarrow \text{TRIS register 'f'}$
Status Affected:	None
Description:	Move data from W register to TRIS register. When 'f' = 5, TRISA is loaded. When 'f' = 6, TRISB is loaded. When 'f' = 7, TRISC is loaded.

<b>XORLW</b>	<b>Exclusive OR literal with W</b>
Syntax:	[ <i>label</i> ] XORLW k
Operands:	$0 \leq k \leq 255$
Operation:	(W) .XOR. k $\rightarrow$ (W)
Status Affected:	Z
Description:	The contents of W are XORed with the 8-bit literal 'k'. The result is placed in W.

<b>XORWF</b>	<b>Exclusive OR W with f</b>
Syntax:	[ <i>label</i> ] XORWF f, d
Operands:	$0 \leq f \leq 127$ $d \in [0,1]$
Operation:	(W) .XOR. (f) $\rightarrow$ dest
Status Affected:	Z
Description:	Exclusive OR the contents of the W register with register 'f'. If 'd' is '0', the result is stored in the W register. If 'd' is '1', the result is stored back in register 'f'.

## **41. Development Support**

The PIC<sup>®</sup> microcontrollers (MCU) and dsPIC<sup>®</sup> digital signal controllers (DSC) are supported with a full range of software and hardware development tools:

- Integrated Development Environment
  - MPLAB<sup>®</sup> X IDE Software
- Compilers/Assemblers/Linkers
  - MPLAB XC Compiler
  - MPASM<sup>™</sup> Assembler
  - MPLINK<sup>™</sup> Object Linker/  
MPLIB<sup>™</sup> Object Librarian
  - MPLAB Assembler/Linker/Librarian for  
Various Device Families
- Simulators
  - MPLAB X SIM Software Simulator
- Emulators
  - MPLAB REAL ICE<sup>™</sup> In-Circuit Emulator
- In-Circuit Debuggers/Programmers
  - MPLAB ICD 3
  - PICKIT<sup>™</sup> 3
- Device Programmers
  - MPLAB PM3 Device Programmer
- Low-Cost Demonstration/Development Boards, Evaluation Kits and Starter Kits
- Third-party development tools

### **41.1 MPLAB X Integrated Development Environment Software**

The MPLAB X IDE is a single, unified graphical user interface for Microchip and third-party software, and hardware development tool that runs on Windows<sup>®</sup>, Linux and Mac OS<sup>®</sup> X. Based on the NetBeans IDE, MPLAB X IDE is an entirely new IDE with a host of free software components and plug-ins for high-performance application development and debugging. Moving between tools and upgrading from software simulators to hardware debugging and programming tools is simple with the seamless user interface.

With complete project management, visual call graphs, a configurable watch window and a feature-rich editor that includes code completion and context menus, MPLAB X IDE is flexible and friendly enough for new users. With the ability to support multiple tools on multiple projects with simultaneous debugging, MPLAB X IDE is also suitable for the needs of experienced users.

Feature-Rich Editor:

- Color syntax highlighting
- Smart code completion makes suggestions and provides hints as you type
- Automatic code formatting based on user-defined rules
- Live parsing

User-Friendly, Customizable Interface:

- Fully customizable interface: toolbars, toolbar buttons, windows, window placement, etc.
- Call graph window

Project-Based Workspaces:

- Multiple projects
- Multiple tools
- Multiple configurations
- Simultaneous debugging sessions

File History and Bug Tracking:

- Local file history feature
- Built-in support for Bugzilla issue tracker

## **41.2 MPLAB XC Compilers**

The MPLAB XC Compilers are complete ANSI C compilers for all of Microchip's 8, 16, and 32-bit MCU and DSC devices. These compilers provide powerful integration capabilities, superior code optimization and ease of use. MPLAB XC Compilers run on Windows, Linux or MAC OS X.

For easy source level debugging, the compilers provide debug information that is optimized to the MPLAB X IDE.

The free MPLAB XC Compiler editions support all devices and commands, with no time or memory restrictions, and offer sufficient code optimization for most applications.

MPLAB XC Compilers include an assembler, linker and utilities. The assembler generates relocatable object files that can then be archived or linked with other relocatable object files and archives to create an executable file. MPLAB XC Compiler uses the assembler to produce its object file. Notable features of the assembler include:

- Support for the entire device instruction set
- Support for fixed-point and floating-point data
- Command-line interface
- Rich directive set
- Flexible macro language
- MPLAB X IDE compatibility

## **41.3 MPASM Assembler**

The MPASM Assembler is a full-featured, universal macro assembler for PIC10/12/16/18 MCUs.

The MPASM Assembler generates relocatable object files for the MPLINK Object Linker, Intel® standard HEX files, MAP files to detail memory usage and symbol reference, absolute LST files that contain source lines and generated machine code, and COFF files for debugging.

The MPASM Assembler features include:

- Integration into MPLAB X IDE projects
- User-defined macros to streamline assembly code

- Conditional assembly for multipurpose source files
- Directives that allow complete control over the assembly process

#### **41.4 MPLINK Object Linker/MPLIB Object Librarian**

The MPLINK Object Linker combines relocatable objects created by the MPASM Assembler. It can link relocatable objects from precompiled libraries, using directives from a linker script.

The MPLIB Object Librarian manages the creation and modification of library files of precompiled code. When a routine from a library is called from a source file, only the modules that contain that routine will be linked in with the application. This allows large libraries to be used efficiently in many different applications.

The object linker/library features include:

- Efficient linking of single libraries instead of many smaller files
- Enhanced code maintainability by grouping related modules together
- Flexible creation of libraries with easy module listing, replacement, deletion and extraction

#### **41.5 MPLAB Assembler, Linker and Librarian for Various Device Families**

MPLAB Assembler produces relocatable machine code from symbolic assembly language for PIC24, PIC32 and dsPIC DSC devices. MPLAB XC Compiler uses the assembler to produce its object file. The assembler generates relocatable object files that can then be archived or linked with other relocatable object files and archives to create an executable file. Notable features of the assembler include:

- Support for the entire device instruction set
- Support for fixed-point and floating-point data
- Command-line interface
- Rich directive set
- Flexible macro language
- MPLAB X IDE compatibility

#### **41.6 MPLAB X SIM Software Simulator**

The MPLAB X SIM Software Simulator allows code development in a PC-hosted environment by simulating the PIC MCUs and dsPIC DSCs on an instruction level. On any given instruction, the data areas can be examined or modified and stimuli can be applied from a comprehensive stimulus controller. Registers can be logged to files for further run-time analysis. The trace buffer and logic analyzer display extend the power of the simulator to record and track program execution, actions on I/O, most peripherals and internal registers.

The MPLAB X SIM Software Simulator fully supports symbolic debugging using the MPLAB XC Compilers, and the MPASM and MPLAB Assemblers. The software simulator offers the flexibility to develop and debug code outside of the hardware laboratory environment, making it an excellent, economical software development tool.

#### **41.7 MPLAB REAL ICE In-Circuit Emulator System**

The MPLAB REAL ICE In-Circuit Emulator System is Microchip's next generation high-speed emulator for Microchip Flash DSC and MCU devices. It debugs and programs all 8, 16 and 32-bit MCU, and DSC devices with the easy-to-use, powerful graphical user interface of the MPLAB X IDE.

The emulator is connected to the design engineer's PC using a high-speed USB 2.0 interface and is connected to the target with either a connector compatible with in-circuit debugger systems (RJ-11) or with the new high-speed, noise tolerant, Low-Voltage Differential Signal (LVDS) interconnection (CAT5).

The emulator is field upgradable through future firmware downloads in MPLAB X IDE. MPLAB REAL ICE offers significant advantages over competitive emulators including full-speed emulation, run-time variable watches, trace analysis, complex breakpoints, logic probes, a ruggedized probe interface and long (up to three meters) interconnection cables.

#### **41.8 MPLAB ICD 3 In-Circuit Debugger System**

The MPLAB ICD 3 In-Circuit Debugger System is Microchip's most cost-effective, high-speed hardware debugger/programmer for Microchip Flash DSC and MCU devices. It debugs and programs PIC Flash microcontrollers and dsPIC DSCs with the powerful, yet easy-to-use graphical user interface of the MPLAB IDE.

The MPLAB ICD 3 In-Circuit Debugger probe is connected to the design engineer's PC using a high-speed USB 2.0 interface and is connected to the target with a connector compatible with the MPLAB ICD 2 or MPLAB REAL ICE systems (RJ-11). MPLAB ICD 3 supports all MPLAB ICD 2 headers.

#### **41.9 PICkit 3 In-Circuit Debugger/Programmer**

The MPLAB PICkit 3 allows debugging and programming of PIC and dsPIC Flash microcontrollers at a most affordable price point using the powerful graphical user interface of the MPLAB IDE. The MPLAB PICkit 3 is connected to the design engineer's PC using a full-speed USB interface and can be connected to the target via a Microchip debug (RJ-11) connector (compatible with MPLAB ICD 3 and MPLAB REAL ICE). The connector uses two device I/O pins and the Reset line to implement in-circuit debugging and In-Circuit Serial Programming™ (ICSP™).

#### **41.10 MPLAB PM3 Device Programmer**

The MPLAB PM3 Device Programmer is a universal, CE compliant device programmer with programmable voltage verification at Vddmin and Vddmax for maximum reliability. It features a large LCD display (128 x 64) for menus and error messages, and a modular, detachable socket assembly to support various package types. The ICSP cable assembly is included as a standard item. In Stand-Alone mode, the MPLAB PM3 Device Programmer can read, verify and program PIC devices without a PC connection. It can also set code protection in this mode. The MPLAB PM3 connects to the host PC via an RS-232 or USB cable. The MPLAB PM3 has high-speed communications and optimized algorithms for quick programming of large memory devices, and incorporates an MMC card for file storage and data applications.

#### **41.11 Demonstration/Development Boards, Evaluation Kits, and Starter Kits**

A wide variety of demonstration, development and evaluation boards for various PIC MCUs and dsPIC DSCs allows quick application development on fully functional systems. Most boards include prototyping



areas for adding custom circuitry and provide application firmware and source code for examination and modification.

The boards support a variety of features, including LEDs, temperature sensors, switches, speakers, RS-232 interfaces, LCD displays, potentiometers and additional EEPROM memory.

The demonstration and development boards can be used in teaching environments, for prototyping custom circuits and for learning about various microcontroller applications.

In addition to the PICDEM™ and dsPICDEM™ demonstration/development board series of circuits, Microchip has a line of evaluation kits and demonstration software for analog filter design, KeeLoq® security ICs, CAN, IrDA®, PowerSmart battery management, SEEVAL® evaluation system, Sigma-Delta ADC, flow rate sensing, plus many more.

Also available are starter kits that contain everything needed to experience the specified device. This usually includes a single application and debug capability, all on one board.

Check the Microchip web page ([www.microchip.com](http://www.microchip.com)) for the complete list of demonstration, development and evaluation kits.

## **41.12 Third-Party Development Tools**

Microchip also offers a great collection of tools from third-party vendors. These tools are carefully selected to offer good value and unique functionality.

- Device Programmers and Gang Programmers from companies, such as SoftLog and CCS
- Software Tools from companies, such as Gimpel and Trace Systems
- Protocol Analyzers from companies, such as Saleae and Total Phase
- Demonstration Boards from companies, such as MikroElektronika, Digilent® and Olimex
- Embedded Ethernet Solutions from companies, such as EZ Web Lynx, WIZnet and IPLogika®

## 42. Electrical Specifications

### 42.1 Absolute Maximum Ratings<sup>(†)</sup>

Parameter	Rating
Ambient temperature under bias	-40°C to +125°C
Storage temperature	-65°C to +150°C
Voltage on pins with respect to V <sub>SS</sub>	
• on V <sub>DD</sub> pin:	
PIC16LF18455/56	-0.3V to +4.0V
PIC16F18455/56	-0.3V to +6.5V
• on $\overline{\text{MCLR}}$ pin:	-0.3V to +9.0V
• on all other pins:	-0.3V to (V <sub>DD</sub> + 0.3V)
Maximum current	
• on V <sub>SS</sub> pin <sup>(1)</sup>	-40°C ≤ T <sub>A</sub> ≤ +85°C      250 mA 85°C < T <sub>A</sub> ≤ +125°C      120 mA
• on V <sub>DD</sub> pin <sup>(1)</sup>	-40°C ≤ T <sub>A</sub> ≤ +85°C      250 mA 85°C < T <sub>A</sub> ≤ +125°C      85 mA
• on any standard I/O pin	±50 mA
Clamp current, I <sub>K</sub> (V <sub>PIN</sub> < 0 or V <sub>PIN</sub> > V <sub>DD</sub> )	±20 mA
Total power dissipation <sup>(2)</sup>	800 mW



**Important:**

- Maximum current rating requires even load distribution across I/O pins. Maximum current rating may be limited by the device package power dissipation characterizations, see [Thermal Characteristics](#) to calculate device specifications.
- Power dissipation is calculated as follows:  

$$P_{DIS} = V_{DD} \times \{I_{DD} - \sum I_{OH}\} + \sum \{(V_{DD} - V_{OH}) \times I_{OH}\} + \sum (V_{OI} \times I_{OL})$$

NOTICE: Stresses above those listed under “*Absolute Maximum Ratings*” may cause permanent damage to the device. This is a stress rating only and functional operation of the device at those or any other conditions above those indicated in the operation listings of this specification is not implied. Exposure above maximum rating conditions for extended periods may affect device reliability.

### 42.2 Standard Operating Conditions

The standard operating conditions for any device are defined as:

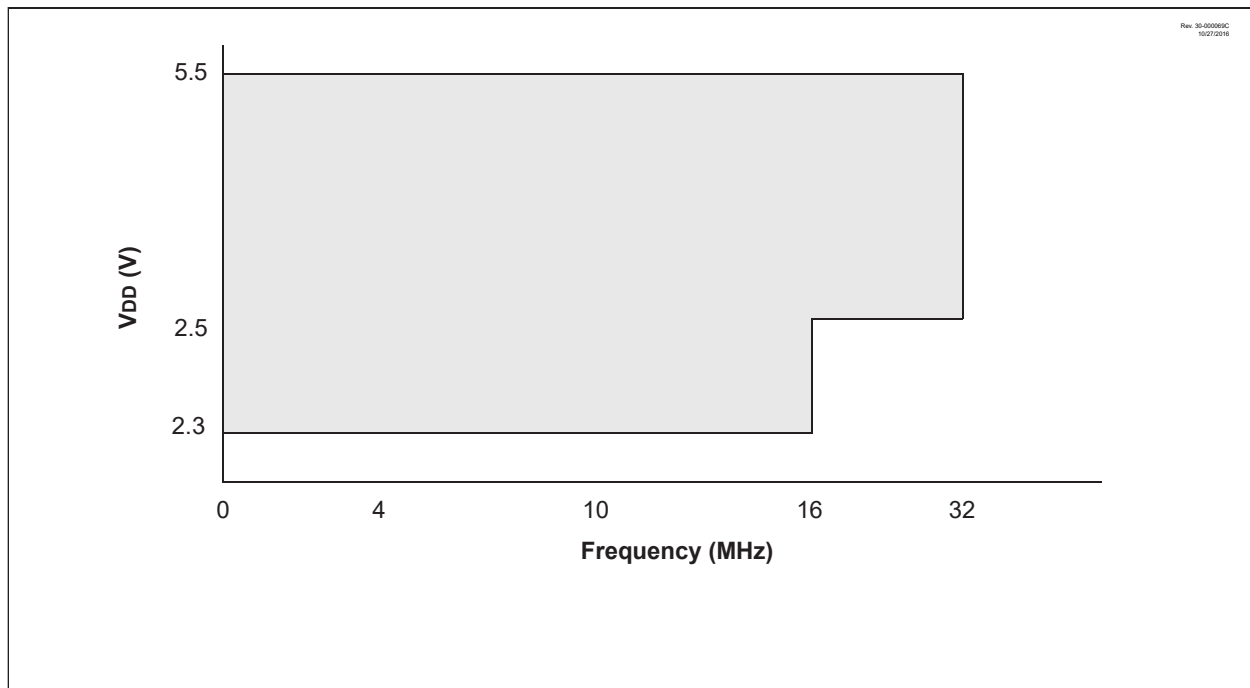
**Operating Voltage:**  $V_{DDMIN} \leq V_{DD} \leq V_{DDMAX}$

$$T_{A\_MIN} \leq T_A \leq T_{A\_MAX}$$

### Operating Temperature:

Parameter		Ratings
<b>V<sub>DD</sub> — Operating Supply Voltage<sup>(1)</sup></b>		
PIC16LF18455/56	V <sub>DDMIN</sub> (F <sub>OSC</sub> ≤ 16 MHz)	+1.8V
	V <sub>DDMIN</sub> (F <sub>OSC</sub> ≤ 32 MHz)	+2.5V
	V <sub>DDMAX</sub>	+3.6V
PIC16F18455/56	V <sub>DDMIN</sub> (F <sub>OSC</sub> ≤ 16 MHz)	+2.3V
	V <sub>DDMIN</sub> (F <sub>OSC</sub> ≤ 32 MHz)	+2.5V
	V <sub>DDMAX</sub>	+5.5V
<b>T<sub>A</sub> — Operating Ambient Temperature Range</b>		
Industrial Temperature	T <sub>A_MIN</sub>	-40°C
	T <sub>A_MAX</sub>	+85°C
Extended Temperature	T <sub>A_MIN</sub>	-40°C
	T <sub>A_MAX</sub>	+125°C
<b>Note:</b>		
1. See Parameter <i>D002</i> , DC Characteristics: Supply Voltage.		

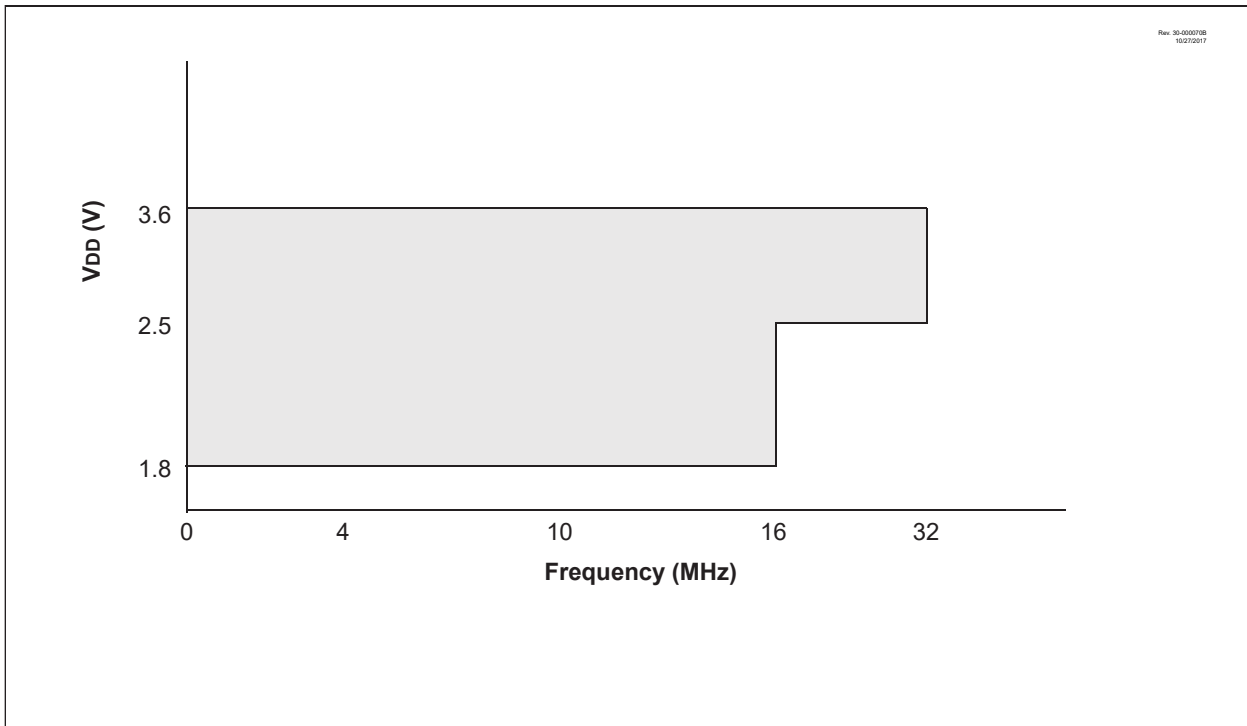
**Figure 42-1. Voltage Frequency Graph, -40°C ≤ T<sub>A</sub> ≤ +125°C, for PIC16F18455/56 only**



### Note:

1. The shaded region indicates the permissible combinations of voltage and frequency.
2. Refer to [42.4.1 External Clock/Oscillator Timing Requirements](#) for each Oscillator mode's supported frequencies.

**Figure 42-2. Voltage Frequency Graph,  $-40^{\circ}\text{C} \leq T_A \leq +125^{\circ}\text{C}$ , for PIC16LF18455/56 Devices only**



**Note:**

1. The shaded region indicates the permissible combinations of voltage and frequency.
2. Refer to [42.4.1 External Clock/Oscillator Timing Requirements](#) for each Oscillator mode's supported frequencies.

**Related Links**

[42.3.1 Supply Voltage](#)

**42.3 DC Characteristics**

**42.3.1 Supply Voltage**

**Table 42-1.**

PIC16LF18455/56 only							
Standard Operating Conditions (unless otherwise stated)							
Param. No.	Sym.	Characteristic	Min.	Typ.†	Max.	Units	Conditions
<b>Supply Voltage</b>							
D002	V <sub>DD</sub>		1.8	—	3.6	V	F <sub>OSC</sub> ≤ 16 MHz
			2.5	—	3.6	V	F <sub>OSC</sub> > 16 MHz
<b>RAM Data Retention<sup>(1)</sup></b>							

# PIC16(L)F18455/56

## Electrical Specifications

### PIC16LF18455/56 only

#### Standard Operating Conditions (unless otherwise stated)

Param. No.	Sym.	Characteristic	Min.	Typ.†	Max.	Units	Conditions
D003	V <sub>DR</sub>		1.5	—	—	V	Device in Sleep mode
<b>Power-on Reset Release Voltage<sup>(2)</sup></b>							
D004	V <sub>POR</sub>		—	1.6	—	V	BOR or LPBOR disabled <sup>(3)</sup>
<b>Power-on Reset Rearm Voltage<sup>(2)</sup></b>							
D005	V <sub>PORR</sub>		—	0.8	—	V	BOR or LPBOR disabled <sup>(3)</sup>
<b>V<sub>DD</sub> Rise Rate to ensure internal Power-on Reset signal<sup>(2)</sup></b>							
D006	S <sub>VDD</sub>		0.05	—	—	V/ms	BOR or LPBOR disabled <sup>(3)</sup>

† - Data in "Typ." column is at 3.0V, 25°C unless otherwise stated. These parameters are for design guidance only and are not tested.

#### Note:

1. This is the limit to which V<sub>DD</sub> can be lowered in Sleep mode without losing RAM data.
2. See the following figure, POR and POR REARM with Slow Rising V<sub>DD</sub>.
3. Please see [42.4.5 Reset, WDT, Oscillator Start-up Timer, Power-up Timer, Brown-Out Reset and Low-Power Brown-Out Reset Specifications](#) for BOR and LPBOR trip point information.

### PIC16F18455/56 only

#### Standard Operating Conditions (unless otherwise stated)

Param. No.	Sym.	Characteristic	Min.	Typ.†	Max.	Units	Conditions
<b>Supply Voltage</b>							
D002	V <sub>DD</sub>		2.3	—	5.5	V	F <sub>OSC</sub> ≤ 16 MHz
			2.5	—	5.5	V	F <sub>OSC</sub> > 16 MHz
<b>RAM Data Retention<sup>(1)</sup></b>							
D003	V <sub>DR</sub>		1.7	—	—	V	Device in Sleep mode
<b>Power-on Reset Release Voltage<sup>(2)</sup></b>							
D004	V <sub>POR</sub>		—	1.6	—	V	BOR or LPBOR disabled <sup>(3)</sup>
<b>Power-on Reset Rearm Voltage<sup>(2)</sup></b>							

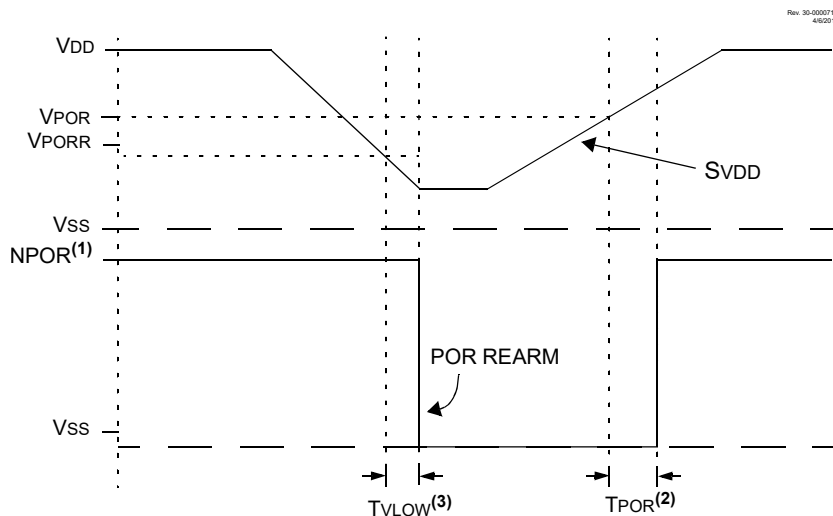
PIC16F18455/56 only							
Standard Operating Conditions (unless otherwise stated)							
Param. No.	Sym.	Characteristic	Min.	Typ.†	Max.	Units	Conditions
D005	$V_{PORR}$		—	1.5	—	V	BOR or LPBOR disabled <sup>(3)</sup>
<b><math>V_{DD}</math> Rise Rate to ensure internal Power-on Reset signal<sup>(2)</sup></b>							
D006	$S_{VDD}$		0.05	—	—	V/ms	BOR or LPBOR disabled <sup>(3)</sup>

† - Data in "Typ." column is at 3.0V, 25°C unless otherwise stated. These parameters are for design guidance only and are not tested.

**Note:**

1. This is the limit to which  $V_{DD}$  can be lowered in Sleep mode without losing RAM data.
2. See the following figure, POR and POR REARM with Slow Rising  $V_{DD}$ .
3. Please see [42.4.5 Reset, WDT, Oscillator Start-up Timer, Power-up Timer, Brown-Out Reset and Low-Power Brown-Out Reset Specifications](#) for BOR and LPBOR trip point information.

Figure 42-3. POR and POR Rearm with Slow Rising  $V_{DD}$



**Note:**

1. When  $NPOR$  is low, the device is held in Reset.
2.  $T_{POR}$  1  $\mu$ s typical.
3.  $T_{VLOW}$  2.7  $\mu$ s typical.

**42.3.2 Supply Current ( $I_{DD}$ )<sup>(1,2,4)</sup>**

**Table 42-2.**

PIC16LF18455/56 only								
Standard Operating Conditions (unless otherwise stated)								
Param. No.	Sym.	Device Characteristics	Min.	Typ.†	Max.	Units	Conditions	
							V <sub>DD</sub>	Note
D100	I <sub>DDXT4</sub>	XT = 4 MHz	—	556.5	845.3	μA	3.0V	
D101	I <sub>DDHFO16</sub>	HFINTOSC = 16 MHz	—	2.1	3.05	mA	3.0V	
D102	I <sub>DDHFOPLL</sub>	HFINTOSC = 32 MHz	—	3.8	5.8	mA	3.0V	
D103	I <sub>DDHSPLL32</sub>	HS+PLL = 32 MHz	—	3.8	5.8	mA	3.0V	
D104	I <sub>DDIDLE</sub>	IDLE mode, HFINTOSC = 16 MHz	—	1.68	2.1	mA	3.0V	
D105	I <sub>DDDOZE</sub> <sup>(3)</sup>	DOZE mode, HFINTOSC = 16 MHz, Doze Ratio = 16	—	1.47	—	mA	3.0V	

† - Data in "Typ." column is at 3.0V, 25°C unless otherwise stated. These parameters are for design guidance only and are not tested.

**Note:**

- The test conditions for all I<sub>DD</sub> measurements in active operation mode are: OSC1 = external square wave, from rail-to-rail; all I/O pins are outputs driven low;  $\overline{MCLR} = V_{DD}$ ; WDT disabled.
- The supply current is mainly a function of the operating voltage and frequency. Other factors, such as I/O pin loading and switching rate, oscillator type, internal code execution pattern and temperature, also have an impact on the current consumption.
- $I_{DDDOZE} = [I_{DDIDLE} * (N-1)/N] + I_{DDHFO} / 16$  where N = DOZE Ratio (see *CPUDOZE* register).
- PMD bits are all in the default state, no modules are disabled.

PIC16F18455/56 only								
Standard Operating Conditions (unless otherwise stated)								
Param. No.	Sym.	Device Characteristics	Min.	Typ.†	Max.	Units	Conditions	
							V <sub>DD</sub>	Note
D100	I <sub>DDXT4</sub>	XT = 4 MHz	—	588	887.25	μA	3.0V	
D101	I <sub>DDHFO16</sub>	HFINTOSC = 16 MHz	—	2.3	3.15	mA	3.0V	

PIC16F18455/56 only								
Standard Operating Conditions (unless otherwise stated)								
Param. No.	Sym.	Device Characteristics	Min.	Typ.†	Max.	Units	Conditions	
							V <sub>DD</sub>	Note
D102	I <sub>DD_HFOPLL</sub>	HFINTOSC = 32 MHz	—	3.9	5.9	mA	3.0V	
D103	I <sub>DD_HSPLL32</sub>	HS+PLL = 32 MHz	—	3.9	6.0	mA	3.0V	
D104	I <sub>DD_IDLE</sub>	IDLE mode, HFINTOSC = 16 MHz	—	1.9	2.2	mA	3.0V	
D105	I <sub>DD_DOZE</sub> <sup>(3)</sup>	DOZE mode, HFINTOSC = 16 MHz, Doze Ratio = 16	—	1.7	—	mA	3.0V	

† - Data in "Typ." column is at 3.0V, 25°C unless otherwise stated. These parameters are for design guidance only and are not tested.

**Note:**

1. The test conditions for all I<sub>DD</sub> measurements in active operation mode are: OSC1 = external square wave, from rail-to-rail; all I/O pins are outputs driven low;  $\overline{MCLR} = V_{DD}$ ; WDT disabled.
2. The supply current is mainly a function of the operating voltage and frequency. Other factors, such as I/O pin loading and switching rate, oscillator type, internal code execution pattern and temperature, also have an impact on the current consumption.
3.  $I_{DD_{DOZE}} = [I_{DD_{IDLE}} * (N-1)/N] + I_{DD_{HFO}} / 16$  where N = DOZE Ratio (see CPUDOZE register).
4. PMD bits are all in the default state, no modules are disabled.

**Related Links**

[11.5.2 CPUDOZE](#)

**42.3.3 Power-Down Current (I<sub>PD</sub>)<sup>(1,2)</sup>**

**Table 42-3.**

PIC16LF18455/56 only									
Standard Operating Conditions (unless otherwise stated)									
Param. No.	Sym.	Device Characteristics	Min.	Typ.†	Max. +85°C	Max. +125°C	Units	Conditions	
								V <sub>DD</sub>	Note
D200	I <sub>PD</sub>	I <sub>PD</sub> Base	—	0.06	2	9	µA	3.0V	
D201	I <sub>PD_WDT</sub>	Low-Frequency Internal Oscillator/WDT	—	0.8	3.0	11	µA	3.0V	



# PIC16(L)F18455/56

## Electrical Specifications

PIC16LF18455/56 only									
Standard Operating Conditions (unless otherwise stated)									
Param. No.	Sym.	Device Characteristics	Min.	Typ.†	Max. +85°C	Max. +125°C	Units	Conditions	
								V <sub>DD</sub>	Note
D202	I <sub>PD_SOSC</sub>	Secondary Oscillator (S <sub>Osc</sub> )	—	0.6	5	11	μA	3.0V	
D203	I <sub>PD_FVR</sub>	FVR	—	33	74	76	μA	3.0V	
D204	I <sub>PD_BOR</sub>	Brown-out Reset (BOR)	—	10	17	19	μA	3.0V	
D205	I <sub>PD_LPBOR</sub>	Low-Power Brown-out Reset (LPBOR)	—	0.5	3.0	10	μA	3.0V	
D207	I <sub>PD_ADCA</sub>	ADC - Non-converting	—	0.06	2	9	μA	3.0V	ADC not converting (4)
D208	I <sub>PD_CMP</sub>	Comparator	—	30	48	56	μA	3.0V	

† - Data in "Typ." column is at 3.0V, 25°C unless otherwise stated. These parameters are for design guidance only and are not tested.

### Note:

1. The peripheral current is the sum of the base I<sub>DD</sub> and the additional current consumed when this peripheral is enabled. The peripheral Δ current can be determined by subtracting the base I<sub>DD</sub> or I<sub>PD</sub> current from this limit. Max. values should be used when calculating total current consumption.
2. The power-down current in Sleep mode does not depend on the oscillator type. Power-down current is measured with the part in Sleep mode with all I/O pins in high-impedance state and tied to V<sub>SS</sub>.
3. All peripheral currents listed are on a per-peripheral basis if more than one instance of a peripheral is available.
4. ADC clock source is FRC.

PIC16F18455/56 only									
Standard Operating Conditions (unless otherwise stated), VREGPM = 1									
Param. No.	Sym.	Device Characteristics	Min.	Typ.†	Max. +85°C	Max. +125°C	Units	Conditions	
								V <sub>DD</sub>	Note
D200			—	0.4	3	12	μA	3.0V	
D200A	I <sub>PD</sub>	I <sub>PD</sub> Base	—	18	25	30	μA	3.0V	VREGPM = 0
D201	I <sub>PD_WDT</sub>	Low-Frequency Internal Oscillator/WDT	—	0.9	4	14	μA	3.0V	

# PIC16(L)F18455/56

## Electrical Specifications

PIC16F18455/56 only									
Standard Operating Conditions (unless otherwise stated), VREGPM = 1									
Param. No.	Sym.	Device Characteristics	Min.	Typ.†	Max. +85°C	Max. +125°C	Units	Conditions	
								V <sub>DD</sub>	Note
D202	I <sub>PD_SOSC</sub>	Secondary Oscillator (S <sub>Osc</sub> )	—	0.8	5.5	13	μA	3.0V	
D203	I <sub>PD_FVR</sub>	FVR	—	28	70	75	μA	3.0V	
D204	I <sub>PD_BOR</sub>	Brown-out Reset (BOR)	—	14	18	20	μA	3.0V	
D207	I <sub>PD_ADCA</sub>	ADC - Non-converting	—	0.4	3	12	μA	3.0V	ADC not converting <sup>(4)</sup>
D208	I <sub>PD_CMP</sub>	Comparator	—	33	49	57	μA	3.0V	

† - Data in "Typ." column is at 3.0V, 25°C unless otherwise stated. These parameters are for design guidance only and are not tested.

**Note:**

1. The peripheral current is the sum of the base I<sub>DD</sub> and the additional current consumed when this peripheral is enabled. The peripheral Δ current can be determined by subtracting the base I<sub>DD</sub> or I<sub>PD</sub> current from this limit. Max. values should be used when calculating total current consumption.
2. The power-down current in Sleep mode does not depend on the oscillator type. Power-down current is measured with the part in Sleep mode with all I/O pins in high-impedance state and tied to V<sub>SS</sub>.
3. All peripheral currents listed are on a per-peripheral basis if more than one instance of a peripheral is available.
4. ADC clock source is FRC.

### 42.3.4 I/O Ports

Table 42-4.

Standard Operating Conditions (unless otherwise stated)							
Param. No.	Sym.	Device Characteristics	Min.	Typ.†	Max.	Units	Conditions
<b>Input Low Voltage</b>							
	V <sub>IL</sub>	I/O PORT:					
D300		• with TTL buffer	—	—	0.8	V	4.5V ≤ V <sub>DD</sub> ≤ 5.5V
D301			—	—	0.15 V <sub>DD</sub>	V	1.8V ≤ V <sub>DD</sub> ≤ 4.5V
D302		• with Schmitt Trigger buffer	—	—	0.2 V <sub>DD</sub>	V	2.0V ≤ V <sub>DD</sub> ≤ 5.5V
D303		• with I <sup>2</sup> C levels	—	—	0.3 V <sub>DD</sub>	V	
D304		• with SMBus levels	—	—	0.8	V	2.7V ≤ V <sub>DD</sub> ≤ 5.5V

# PIC16(L)F18455/56

## Electrical Specifications

### Standard Operating Conditions (unless otherwise stated)

Param. No.	Sym.	Device Characteristics	Min.	Typ.†	Max.	Units	Conditions
D305		MCLR	—	—	$0.2 V_{DD}$	V	
<b>Input High Voltage</b>							
	$V_{IH}$	I/O PORT:					
D320		• with TTL buffer	2.0	—	—	V	$4.5V \leq V_{DD} \leq 5.5V$
D321			$0.25 V_{DD} + 0.8$	—	—	V	$1.8V \leq V_{DD} \leq 4.5V$
D322		• with Schmitt Trigger buffer	$0.8V_{DD}$	—	—	V	$2.0V \leq V_{DD} \leq 5.5V$
D323		• with I <sup>2</sup> C levels	$0.7 V_{DD}$	—	—	V	
D324		• with SMBus levels	2.1	—	—	V	$2.7V \leq V_{DD} \leq 5.5V$
D325		MCLR	$0.7 V_{DD}$	—	—	V	
<b>Input Leakage Current<sup>(1)</sup></b>							
D340	$I_{IL}$	I/O PORTS	—	$\pm 5$	$\pm 125$	nA	$V_{SS} \leq V_{PIN} \leq V_{DD}$ , Pin at high-impedance, 85°C
D341			—	$\pm 5$	$\pm 1000$	nA	$V_{SS} \leq V_{PIN} \leq V_{DD}$ , Pin at high-impedance, 125°C
D342		MCLR <sup>(2)</sup>	—	$\pm 50$	$\pm 200$	nA	$V_{SS} \leq V_{PIN} \leq V_{DD}$ , Pin at high-impedance, 85°C
<b>Weak Pull-up Current</b>							
D350	$I_{PUR}$		25	120	200	$\mu A$	$V_{DD} = 3.0V$ , $V_{PIN} = V_{SS}$
<b>Output Low Voltage</b>							
D360	$V_{OL}$	Standard I/O PORTS	—	—	0.6	V	$I_{OL} = 8 \text{ mA}$ , $V_{DD} = 5.0V$ $I_{OL} = 6 \text{ mA}$ , $V_{DD} = 3.3V$ $I_{OL} = 1.8 \text{ mA}$ , $V_{DD} = 1.8V$
D360A		High-Drive I/O PORTS	—	—	0.6	V	$I_{OL} = 10 \text{ mA}$ , $V_{DD} = 2.3V$ , $HIDC_x = 1$ $I_{OL} = 32 \text{ mA}$ , $V_{DD} = 3.0V$ , $HIDC_x = 1$ $I_{OL} = 51 \text{ mA}$ , $V_{DD} = 5.0V$ , $HIDC_x = 1$

# PIC16(L)F18455/56

## Electrical Specifications

Standard Operating Conditions (unless otherwise stated)							
Param. No.	Sym.	Device Characteristics	Min.	Typ.†	Max.	Units	Conditions
<b>Output High Voltage</b>							
D370	V <sub>OH</sub>	Standard I/O PORTS	V <sub>DD</sub> -0.7	—	—	V	I <sub>OH</sub> = 3.5 mA, V <sub>DD</sub> = 5.0V I <sub>OH</sub> = 3 mA, V <sub>DD</sub> = 3.3V I <sub>OH</sub> = 1 mA, V <sub>DD</sub> = 1.8V
D370A		High-Drive I/O PORTS	V <sub>DD</sub> -0.7	— V <sub>DD</sub> -0.7 V <sub>DD</sub> -0.7	— — —	V V V	I <sub>OH</sub> = 10 mA, V <sub>DD</sub> = 2.3V, HIDC <sub>x</sub> = 1 I <sub>OH</sub> = 37 mA, V <sub>DD</sub> = 3.0V, HIDC <sub>x</sub> = 1 I <sub>OH</sub> = 54 mA, V <sub>DD</sub> = 5.0V, HIDC <sub>x</sub> = 1
<b>All I/O Pins</b>							
D380	C <sub>IO</sub>		—	5	50	pF	
† - Data in "Typ" column is at 3.0V, 25°C unless otherwise stated. These parameters are for design guidance only and are not tested.							
<b>Note:</b>							
1. Negative current is defined as current sourced by the pin.							
2. The leakage current on the $\overline{\text{MCLR}}$ pin is strongly dependent on the applied voltage level. The specified levels represent normal operating conditions. Higher leakage current may be measured at different input voltages.							

### 42.3.5 Memory Programming Specifications

Table 42-5.

Standard Operating Conditions (unless otherwise stated)							
Param No.	Sym.	Device Characteristics	Min.	Typ†	Max.	Units	Conditions
<b>High Voltage Entry Programming Mode Specifications</b>							
MEM01	V <sub>IHH</sub>	Voltage on $\overline{\text{MCLR}}$ /V <sub>PP</sub> pin to enter programming mode	8	—	9	V	(Note 2, Note 3)
MEM02	I <sub>PPGM</sub>	Current on $\overline{\text{MCLR}}$ /V <sub>PP</sub> pin during programming mode	—	1	—	mA	(Note 2)
<b>Programming Mode Specifications</b>							
MEM10	V <sub>BE</sub>	V <sub>DD</sub> for Bulk Erase	—	—	—	V	(Note 4)

# PIC16(L)F18455/56

## Electrical Specifications

Standard Operating Conditions (unless otherwise stated)							
Param No.	Sym.	Device Characteristics	Min.	Typ†	Max.	Units	Conditions
MEM11	I <sub>DDPGM</sub>	Supply Current during Programming operation	—	—	10	mA	
<b>Data EEPROM Memory Specifications</b>							
MEM20	E <sub>D</sub>	DataEE Byte Endurance	100k	—	—	E/W	-40°C ≤ T <sub>A</sub> ≤ +85°C
MEM21	T <sub>D_RET</sub>	Characteristic Retention	—	40	—	Year	Provided no other specifications are violated
MEM22	N <sub>D_REF</sub>	Total Erase/Write Cycles before Refresh	—	—	100k	E/W	
MEM23	V <sub>D_RW</sub>	V <sub>DD</sub> for Read or Erase/Write operation	V <sub>DDMIN</sub>	—	V <sub>DDMAX</sub>	V	
MEM24	T <sub>D_BEW</sub>	Byte Erase and Write Cycle Time	—	4.0	5.0	ms	
<b>Program Flash Memory Specifications</b>							
MEM30	E <sub>P</sub>	Flash Memory Cell Endurance	10k	—	—	E/W	-40°C ≤ T <sub>a</sub> ≤ +85°C (Note 1)
MEM32	T <sub>P_RET</sub>	Characteristic Retention	—	40	—	Year	Provided no other specifications are violated
MEM33	V <sub>P_RD</sub>	V <sub>DD</sub> for Read operation	V <sub>DDMIN</sub>	—	V <sub>DDMAX</sub>	V	
MEM34	V <sub>P_REW</sub>	V <sub>DD</sub> for Row Erase or Write operation	V <sub>DDMIN</sub>	—	V <sub>DDMAX</sub>	V	
MEM35	T <sub>P_REW</sub>	Self-Timed Row Erase or Self-Timed Write	—	2.0	2.5	ms	
† - Data in "Typ" column is at 3.0V, 25°C unless otherwise stated. These parameters are for design guidance only and are not tested.							
<b>Note:</b>							

Standard Operating Conditions (unless otherwise stated)							
Param No.	Sym.	Device Characteristics	Min.	Typ†	Max.	Units	Conditions
<ol style="list-style-type: none"> <li>Flash Memory Cell Endurance for the Flash memory is defined as: One Row Erase operation and one Self-Timed Write.</li> <li>Required only if CONFIG4, bit LVP is disabled.</li> <li>The MPLAB® ICD2 does not support variable V<sub>PP</sub> output. Circuitry to limit the ICD2 V<sub>PP</sub> voltage must be placed between the ICD2 and target system when programming or debugging with the ICD2.</li> <li>Refer to the "PIC16(L)F184XX Memory Programming Specification" document for description.</li> </ol>							

**Related Links**

[4.7.4 CONFIG4](#)

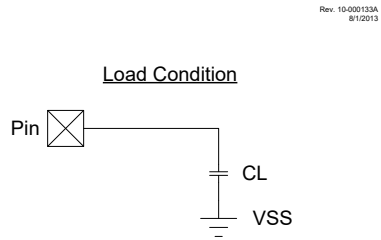
**42.3.6 Thermal Characteristics**

**Table 42-6.**

Standard Operating Conditions (unless otherwise stated)					
Operating temperature -40°C ≤ TA ≤ +125°C					
Param No.	Sym.	Characteristic	Typ.	Units	Conditions
TH01	θ <sub>JA</sub>	Thermal Resistance Junction to Ambient	55	°C/W	28-pin SPDIP package
			74	°C/W	28-pin SOIC package
			67.1	°C/W	28-pin SSOP package
			—	°C/W	28-pin VQFN 4x4 mm package
TH02	θ <sub>JC</sub>	Thermal Resistance Junction to Case	36	°C/W	28-pin SPDIP package
			19	°C/W	28-pin SOIC package
			23.9	°C/W	28-pin SSOP package
			—	°C/W	28-pin VQFN 4x4 mm package
TH03	T <sub>JMAX</sub>	Maximum Junction Temperature	—	°C	T <sub>JMAX</sub> = T <sub>AMAX</sub> + (PD <sub>MAX</sub> × θ <sub>JA</sub> ) (2)
TH04	PD	Power Dissipation	—	W	PD = P <sub>INTERNAL</sub> + P <sub>I/O</sub>
TH05	P <sub>INTERNAL</sub>	Internal Power Dissipation	—	W	P <sub>INTERNAL</sub> = I <sub>DD</sub> × V <sub>DD</sub> (1)
TH06	P <sub>I/O</sub>	I/O Power Dissipation	—	W	P <sub>I/O</sub> = Σ(I <sub>OL</sub> × V <sub>OL</sub> ) + Σ(I <sub>OH</sub> × (V <sub>DD</sub> - V <sub>OH</sub> ))
TH07	P <sub>DER</sub>	Derated Power	—	W	P <sub>DER</sub> = PD <sub>MAX</sub> (T <sub>J</sub> - T <sub>A</sub> ) / θ <sub>JA</sub> (2)
<b>Note:</b>					
<ol style="list-style-type: none"> <li>I<sub>DD</sub> is current to run the chip alone without driving any load on the output pins.</li> <li>T<sub>A</sub> = Ambient Temperature, T<sub>J</sub> = Junction Temperature.</li> </ol>					

## 42.4 AC Characteristics

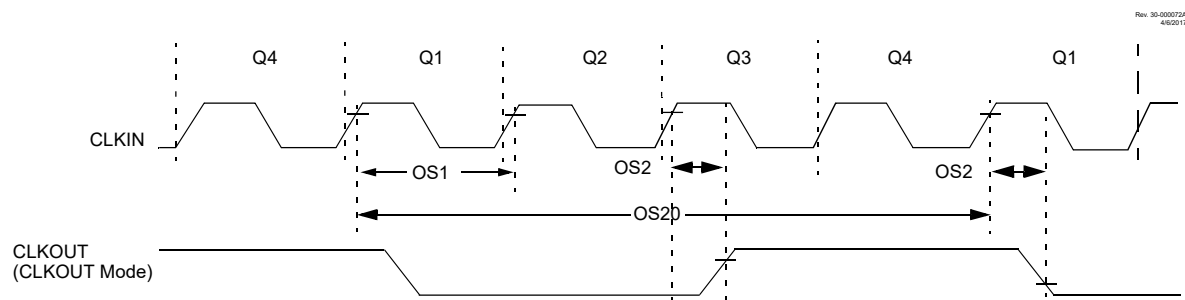
Figure 42-4. Load Conditions



Legend: CL=50 pF for all pins

### 42.4.1 External Clock/Oscillator Timing Requirements

Figure 42-5. Clock Timing



Note: See table below.

Table 42-7.

Standard Operating Conditions (unless otherwise stated)							
Param No.	Sym.	Characteristic	Min.	Typ. †	Max.	Units	Conditions
<b>ECL Oscillator</b>							
OS1	$F_{ECL}$	Clock Frequency	—	—	500	kHz	
OS2	$T_{ECL\_DC}$	Clock Duty Cycle	40	—	60	%	
<b>ECM Oscillator</b>							
OS3	$F_{ECM}$	Clock Frequency	—	—	4	MHz	
OS4	$T_{ECM\_DC}$	Clock Duty Cycle	40	—	60	%	
<b>ECH Oscillator</b>							
OS5	$F_{ECH}$	Clock Frequency	—	—	32	MHz	
OS6	$T_{ECH\_DC}$	Clock Duty Cycle	40	—	60	%	
<b>LP Oscillator</b>							
OS7	$F_{LP}$	Clock Frequency	—	—	100	kHz	<b>Note 4</b>

Standard Operating Conditions (unless otherwise stated)							
Param No.	Sym.	Characteristic	Min.	Typ. †	Max.	Units	Conditions
<b>XT Oscillator</b>							
OS8	F <sub>XT</sub>	Clock Frequency	—	—	4	MHz	Note 4
<b>HS Oscillator</b>							
OS9	F <sub>HS</sub>	Clock Frequency	—	—	20	MHz	Note 4
<b>Secondary Oscillator</b>							
OS10	F <sub>SEC</sub>	Clock Frequency	32.4	32.768	33.1	kHz	Note 4
<b>System Oscillator</b>							
OS20	F <sub>OSC</sub>	System Clock Frequency	—	—	32	MHz	(Note 2, Note 3)
OS21	F <sub>CY</sub>	Instruction Frequency	—	F <sub>OSC</sub> /4	—	MHz	
OS22	T <sub>CY</sub>	Instruction Period	125	1/F <sub>CY</sub>	—	ns	

\* These parameters are characterized but not tested.

† - Data in "Typ" column is at 3.0V, 25°C unless otherwise stated. These parameters are for design guidance only and are not tested.

**Note:**

1. Instruction cycle period (T<sub>CY</sub>) equals four times the input oscillator time base period. All specified values are based on characterization data for that particular oscillator type under standard operating conditions with the device executing code. Exceeding these specified limits may result in an unstable oscillator operation and/or higher than expected current consumption. All devices are tested to operate at "min" values with an external clock applied to OSC1 pin. When an external clock input is used, the "max" cycle time limit is "DC" (no clock) for all devices.
2. The system clock frequency (F<sub>OSC</sub>) is selected by the "main clock switch controls" as described in the "Oscillator Module (with Fail-Safe Clock Monitor)" section.
3. The system clock frequency (F<sub>OSC</sub>) must meet the voltage requirements defined in the "Standard Operating Conditions" section.
4. LP, XT and HS oscillator modes require an appropriate crystal or resonator to be connected to the device. For clocking the device with the external square wave, one of the EC mode selections must be used.

**Related Links**

[9. Oscillator Module \(with Fail-Safe Clock Monitor\)](#)

[42.2 Standard Operating Conditions](#)



**42.4.2 Internal Oscillator Parameters<sup>(1)</sup>**

**Table 42-8.**

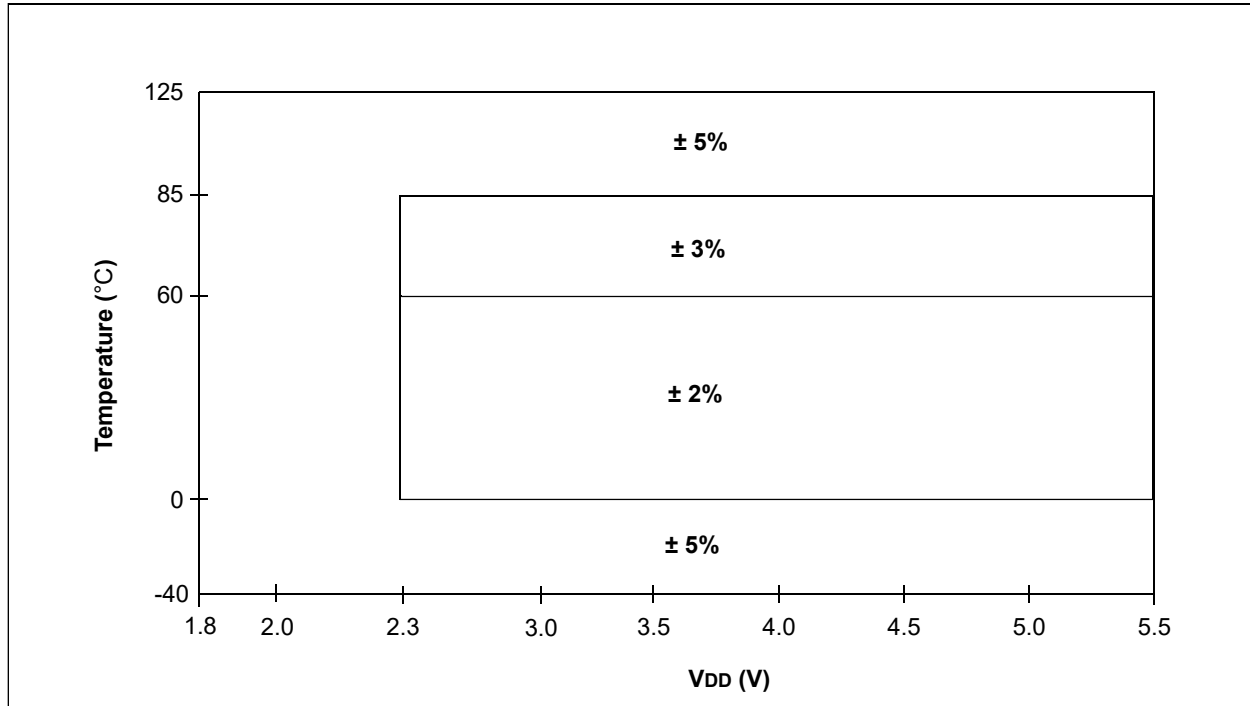
Standard Operating Conditions (unless otherwise stated)							
Param No.	Sym.	Characteristic	Min.	Typ. †	Max.	Units	Conditions
OS50	F <sub>HFOSC</sub>	Precision Calibrated HFINTOSC Frequency	—	4	—	MHz	(Note 2)
				8			
				12			
				16			
				32			
OS51	F <sub>HFOSCLP</sub>	Low-Power Optimized HFINTOSC Frequency	—	1	—	MHz	
				2		MHz	
OS52	F <sub>MFOSC</sub>	Internal Calibrated MFINTOSC Frequency	—	500	—	kHz	
OS53	F <sub>LFOSC</sub>	Internal LFINTOSC Frequency	—	31	—	kHz	
OS54	T <sub>HFOSCST</sub>	HFINTOSC Wake-up from Sleep Start-up Time	—	11	20	μs	VREGPM=0
				85	—	μs	VREGPM=1
OS56	T <sub>LFOSCST</sub>	LFINTOSC Wake-up from Sleep Start-up Time	—	0.2	—	ms	

† - Data in "Typ" column is at 3.0V, 25°C unless otherwise stated. These parameters are for design guidance only and are not tested.

**Note:**

- To ensure these oscillator frequency tolerances, V<sub>DD</sub> and V<sub>SS</sub> must be capacitively decoupled as close to the device as possible. 0.1 μF and 0.01 μF values in parallel are recommended.
- See the figure below.

Figure 42-6. Precision Calibrated HFINTOSC Frequency Accuracy Over Device V<sub>DD</sub> and Temperature



#### 42.4.3 PLL Specifications

Table 42-9.

Standard Operating Conditions (unless otherwise stated)							
Param No.	Sym.	Characteristic	Min.	Typ. †	Max.	Units	Conditions
PLL01	F <sub>PLLIN</sub>	PLL Input Frequency Range	4	—	16	MHz	
PLL02	F <sub>PLLOUT</sub>	PLL Output Frequency Range	16	—	32	MHz	(Note 1)
PLL03	F <sub>PLLST</sub>	PLL Lock Time from Start-up	—	200	—	μs	
PLL04	F <sub>PLLJIT</sub>	PLL Output Frequency Stability (Jitter)	-0.25	—	0.25	%	

\* - These parameters are characterized but not tested.

† - Data in "Typ" column is at 5.0V, 25°C unless otherwise stated. These parameters are for design guidance only and are not tested.

**Note:**

1. The output frequency of the PLL must meet the F<sub>OSC</sub> requirements listed in Parameter [D002](#).

42.4.4 I/O and CLKOUT Timing Specifications

Figure 42-7. CLKOUT and I/O Timing

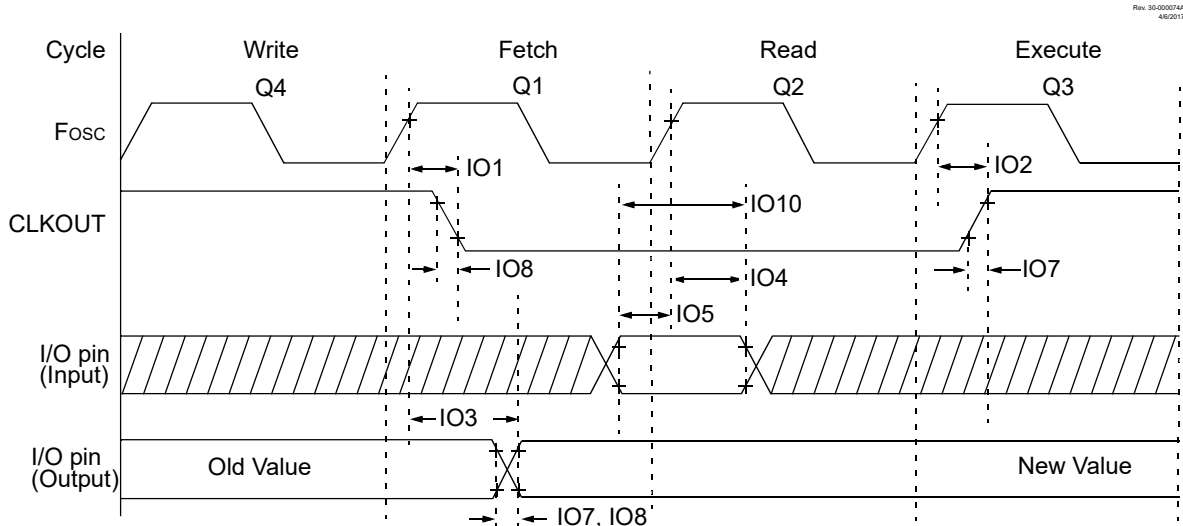


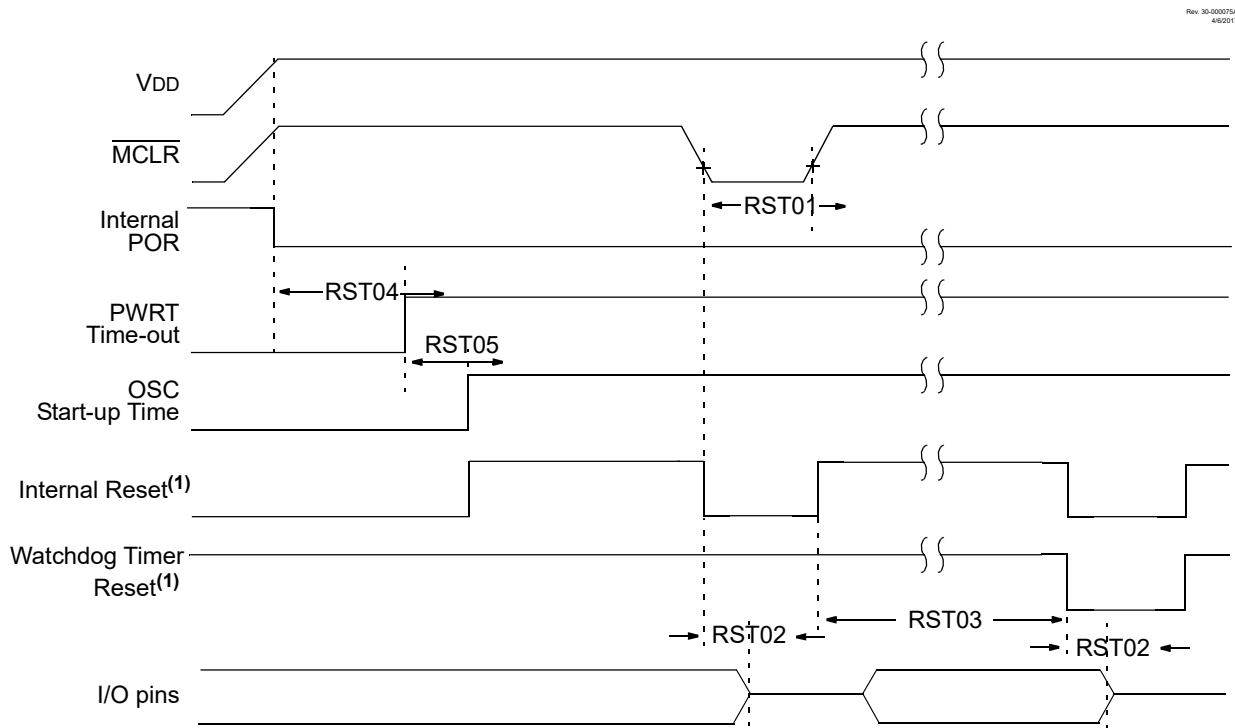
Table 42-10. I/O and CLKOUT Timing Specifications

Standard Operating Conditions (unless otherwise stated)							
Param No.	Sym.	Characteristic	Min.	Typ. †	Max.	Units	Conditions
IO1*	$T_{CLKOUTH}$	CLKOUT rising edge delay (rising edge $F_{OSC}$ (Q1 cycle) to falling edge CLKOUT)	—	—	70	ns	
IO2*	$T_{CLKOUTL}$	CLKOUT falling edge delay (rising edge $F_{OSC}$ (Q3 cycle) to rising edge CLKOUT)	—	—	72	ns	
IO3*	$T_{IO\_VALID}$	Port output valid time (rising edge $F_{OSC}$ (Q1 cycle) to port valid)	—	50	70	ns	
IO4*	$T_{IO\_SETUP}$	Port input setup time (Setup time before rising edge $F_{OSC}$ – Q2 cycle)	20	—	—	ns	
IO5*	$T_{IO\_HOLD}$	Port input hold time (Hold time after rising edge $F_{OSC}$ – Q2 cycle)	50	—	—	ns	
IO6*	$T_{IOR\_SLREN}$	Port I/O rise time, slew rate enabled	—	25	—	ns	$V_{DD}=3.0V$
IO7*	$T_{IOR\_SLRDIS}$	Port I/O rise time, slew rate disabled	—	5	—	ns	$V_{DD}=3.0V$
IO8*	$T_{IOF\_SLREN}$	Port I/O fall time, slew rate enabled	—	25	—	ns	$V_{DD}=3.0V$
IO9*	$T_{IOF\_SLRDIS}$	Port I/O fall time, slew rate disabled	—	5	—	ns	$V_{DD}=3.0V$
IO10*	$T_{INT}$	INT pin high or low time to trigger an interrupt	25	—	—	ns	
IO11*	$T_{IOC}$	Interrupt-on-Change minimum high or low time to trigger interrupt	25	—	—	ns	

\* - These parameters are characterized but not tested.

42.4.5 Reset, WDT, Oscillator Start-up Timer, Power-up Timer, Brown-Out Reset and Low-Power Brown-Out Reset Specifications

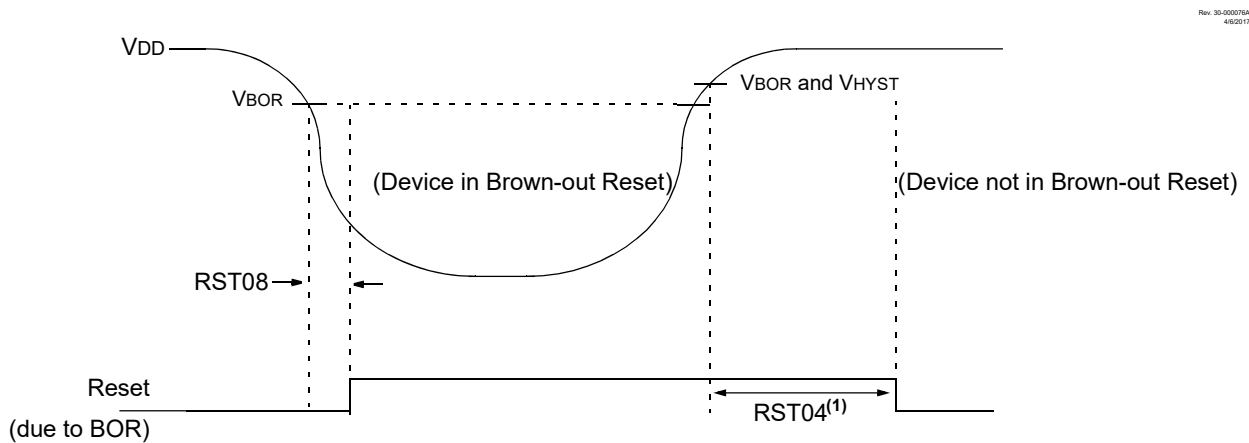
Figure 42-8. Reset, Watchdog Timer, Oscillator Start-up Timer and Power-up Timer Timing



**Note:**

1. Asserted low.

Figure 42-9. Brown-out Reset Timing and Characteristics



**Note:**

1. Only if  $\overline{\text{PWRTE}}$  bit in the Configuration Word register is programmed to '1'; 2 ms delay if  $\overline{\text{PWRTE}} = 0$ .

**Table 42-11.**

Standard Operating Conditions (unless otherwise stated)							
Param No.	Sym.	Characteristic	Min.	Typ. †	Max.	Units	Conditions
RST01*	T <sub>MCLR</sub>	MCLR Pulse Width Low to ensure Reset	2	—	—	μs	
RST02*	T <sub>IOZ</sub>	I/O high-impedance from Reset detection	—	—	2	μs	
RST03	T <sub>WDT</sub>	Watchdog Timer Time-out Period	—	16	—	ms	1:512 Prescaler
RST04*	T <sub>PWRT</sub>	Power-up Timer Period	—	65	—	ms	
RST05	T <sub>OST</sub>	Oscillator Start-up Timer Period <sup>(1, 2)</sup>	—	1024	—	T <sub>OSC</sub>	
RST06	V <sub>BOR</sub>	Brown-out Reset Voltage	2.55 2.30 1.80	2.7 2.45 1.90	2.85 2.60 <sup>(3)</sup> 2.05	V V V	BORV=0 BORV=1(F devices only) BORV=1(LF Devices only)
RST07	V <sub>BORHYS</sub>	Brown-out Reset Hysteresis	—	40	—	mV	
RST08	T <sub>BORDC</sub>	Brown-out Reset Response Time	—	3	—	μs	
RST09	V <sub>LPBOR</sub>	Low-Power Brown-out Reset Voltage	1.8	1.9	2.2	V	

\* - These parameters are characterized but not tested.

† Data in “Typ” column is at 3.0V, 25°C unless otherwise stated. These parameters are for design guidance only and are not tested.

**Note:**

1. By design, the Oscillator Start-up Timer (OST) counts the first 1024 cycles, independent of frequency.
2. To ensure these voltage tolerances, V<sub>DD</sub> and V<sub>SS</sub> must be capacitively decoupled as close to the device as possible. 0.1 μF and 0.01 μF values in parallel are recommended.
3. This value corresponds to V<sub>BORMAX</sub>

**42.4.6 Temperature Indicator Requirements**

**Table 42-12.**

Standard Operating Conditions (unless otherwise stated)								
Param. No.	Sym.	Characteristic	Min.	Typ. †	Max.	Units	Conditions	
TS01	T <sub>ACQMIN</sub>	Minimum ADC Acquisition Time Delay	—	25	—	μs		
TS02	Mv	Voltage Sensitivity	High Range	—	-3.684	—	mV/°C	TSRNG = 1
			Low Range	—	-3.456	—	mV/°C	TSRNG = 0

\* - These parameters are characterized but not tested.

† Data in “Typ” column is at 3.0V, 25°C unless otherwise stated. These parameters are for design guidance only and are not tested.

**42.4.7 Analog-To-Digital Converter (ADC) Accuracy Specifications<sup>(1,2)</sup>**

**Table 42-13.**

Standard Operating Conditions (unless otherwise stated)							
V <sub>DD</sub> = 3.0V, T <sub>A</sub> = 25°C, T <sub>AD</sub> = 1μs							
Param No.	Sym.	Characteristic	Min.	Typ. †	Max.	Units	Conditions
AD01	N <sub>R</sub>	Resolution	—	—	12	bit	
AD02	E <sub>IL</sub>	Integral Error	—	±0.2	±1.0	Lsb	ADC <sub>REF+</sub> = 3.0V, ADC <sub>REF-</sub> = 0V
AD03	E <sub>DL</sub>	Differential Error	—	±1.0	±1.0	Lsb	ADC <sub>REF+</sub> = 3.0V, ADC <sub>REF-</sub> = 0V
AD04	E <sub>OFF</sub>	Offset Error	—	0.5	6.5	Lsb	ADC <sub>REF+</sub> = 3.0V, ADC <sub>REF-</sub> = 0V
AD05	E <sub>GN</sub>	Gain Error	—	±0.2	±6.0	Lsb	ADC <sub>REF+</sub> = 3.0V, ADC <sub>REF-</sub> = 0V
AD06	V <sub>ADREF</sub>	ADC Reference Voltage (AD <sub>REF+</sub> - AD <sub>REF-</sub> )	1.8	—	V <sub>DD</sub>	V	
AD07	V <sub>AIN</sub>	Full-Scale Range	AD <sub>REF-</sub>	—	AD <sub>REF+</sub>	V	
AD08	Z <sub>AIN</sub>	Recommended Impedance of Analog Voltage Source	—	10	—	kΩ	
AD09	R <sub>VREF</sub>	ADC Voltage Reference Ladder Impedance	—	50	—	kΩ	

\* - These parameters are characterized but not tested.

**Standard Operating Conditions (unless otherwise stated)**

$V_{DD} = 3.0V$ ,  $T_A = 25^{\circ}C$ ,  $T_{AD} = 1\mu s$

Param No.	Sym.	Characteristic	Min.	Typ. †	Max.	Units	Conditions
-----------	------	----------------	------	--------	------	-------	------------

† Data in “Typ” column is at 3.0V, 25°C unless otherwise stated. These parameters are for design guidance only and are not tested.

**Note:**

1. Total Absolute Error is the sum of the offset, gain and integral non-linearity (INL) errors.
2. The ADC conversion result never decreases with an increase in the input and has no missing codes.

**42.4.8 Analog-to-Digital Converter (ADC) Conversion Timing Specifications**

**Table 42-14.**

**Standard Operating Conditions (unless otherwise stated)**

Param No.	Sym.	Characteristic	Min.	Typ. †	Max.	Units	Conditions
AD20	$T_{AD}$	ADC Clock Period	1	—	9	$\mu s$	Using $F_{OSC}$ as the ADC clock source $ADCS = 1$
AD21			—	2	—	$\mu s$	Using $F_{RC}$ as the ADC clock source $ADCS = 0$
AD22	$T_{CNV}$	Conversion Time <sup>(1)</sup>	—	$13T_{AD}+3T_{CY}$	—	—	Using $F_{OSC}$ as the ADC clock source $ADCS = 1$
			—	$16T_{AD}+2T_{CY}$	—	—	Using $F_{RC}$ as the ADC clock source $ADCS = 0$
AD23	$T_{ACQ}$	Acquisition Time	—	2	—	$\mu s$	
AD24	$T_{HCD}$	Sample and Hold Capacitor Disconnect Time	—	$2T_{AD}+1T_{CY}$	—	—	Using $F_{OSC}$ as the ADC clock source $ADCS = 1$
			—	$3T_{AD}+2T_{CY}$	—	—	Using $F_{RC}$ as the ADC clock source $ADCS = 0$

\* - These parameters are characterized but not tested.

† Data in “Typ” column is at 3.0V, 25°C unless otherwise stated. These parameters are for design guidance only and are not tested.

**Note:**

1. Does not apply for the ADCRC oscillator.

Figure 42-10. ADC Conversion Timing (ADC Clock  $F_{OSC}$ -Based)

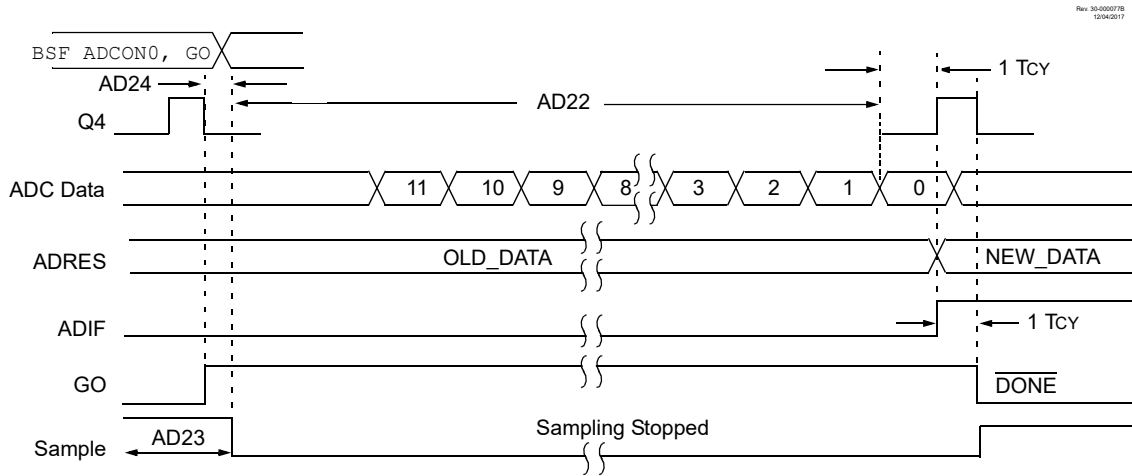
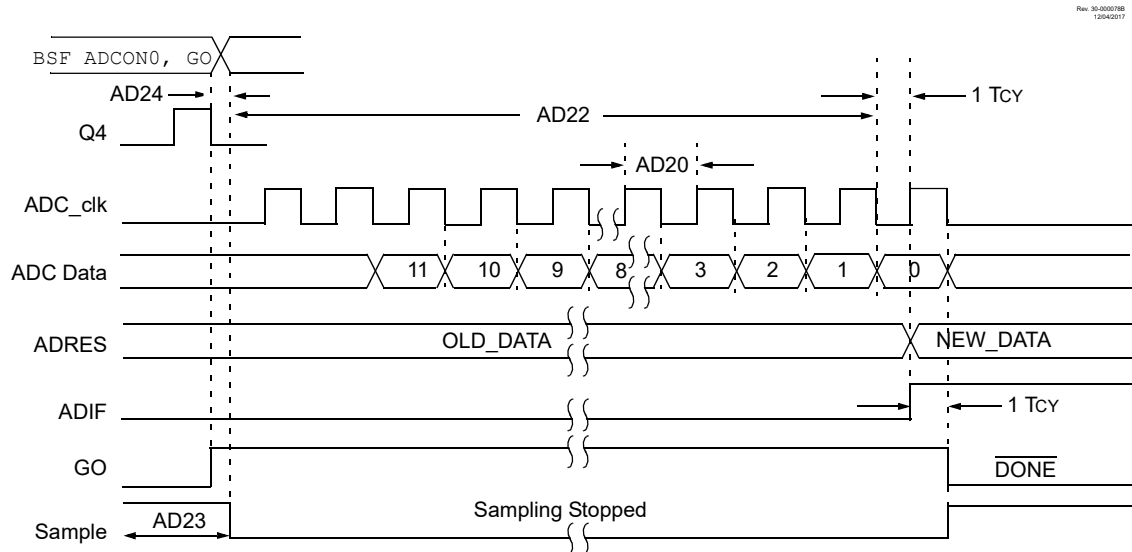


Figure 42-11. ADC Conversion Timing (ADC Clock from ADCRC)



**Note:**

1. If the ADC clock source is selected as ADCRC, a time of  $T_{CY}$  is added before the ADC clock starts. This allows the `SLEEP` instruction to be executed.



42.4.9 Comparator Specifications

Table 42-15.

Standard Operating Conditions (unless otherwise stated)							
$V_{DD} = 3.0V, T_A = 25^\circ C$							
Param No.	Sym.	Characteristic	Min.	Typ. †	Max.	Units	Conditions
CM01	$V_{IOFF}$	Input Offset Voltage	—	±30	—	mV	$V_{ICM} = V_{DD}/2$
CM02	$V_{ICM}$	Input Common Mode Range	GND	—	$V_{DD}$	V	
CM03	CMRR	Common Mode Input Rejection Ratio	—	50	—	dB	
CM04	$V_{HYST}$	Comparator Hysteresis	15	25	35	mV	
CM05	$T_{RESP}^{(1)}$	Response Time, Rising Edge	—	300	600	ns	
		Response Time, Falling Edge	—	220	500	ns	
CM06*	$T_{MCV2VO}^{(2)}$	Mode Change to Valid Output	—	—	10	ns	

\* - These parameters are characterized but not tested.

† Data in “Typ” column is at 3.0V, 25°C unless otherwise stated. These parameters are for design guidance only and are not tested.

**Note:**

1. Response time measured with one comparator input at  $V_{DD}/2$ , while the other input transitions from  $V_{SS}$  to  $V_{DD}$ .
2. A mode change includes changing any of the control register values, including module enable.

42.4.10 5-Bit DAC Specifications

Table 42-16.

Standard Operating Conditions (unless otherwise stated)							
$V_{DD} = 3.0V, T_A = 25^\circ C$							
Param No.	Sym.	Characteristic	Min.	Typ. †	Max.	Units	Conditions
DSB01	$V_{LSB}$	Step Size	—	$(V_{DACREF+} - V_{DACREF-})/32$	—	V	
DSB02	$V_{ACC}$	Absolute Accuracy	—	—	±0.5	LSb	

Standard Operating Conditions (unless otherwise stated)							
$V_{DD} = 3.0V, T_A = 25^{\circ}C$							
Param No.	Sym.	Characteristic	Min.	Typ. †	Max.	Units	Conditions
DSB03*	R <sub>UNIT</sub>	Unit Resistor Value	—	5000	—	Ω	
DSB04*	T <sub>ST</sub>	Settling Time <sup>(1)</sup>	—	—	10	μs	

\* - These parameters are characterized but not tested.

† Data in “Typ” column is at 3.0V, 25°C unless otherwise stated. These parameters are for design guidance only and are not tested.

**Note:**

- Settling time measured while DACR<4:0> transitions from ‘00000’ to ‘01111’.

#### 42.4.11 Fixed Voltage Reference (FVR) Specifications

Table 42-17.

Standard Operating Conditions (unless otherwise stated)							
Param No.	Sym.	Characteristic	Min.	Typ. †	Max.	Units	Conditions
FVR01	V <sub>FVR1</sub>	1x Gain (1.024V)	-4	—	+4	%	VDD≥2.5V, -40°C to 85°C
FVR02	V <sub>FVR2</sub>	2x Gain (2.048V)	-4	—	+4	%	VDD≥2.5V, -40°C to 85°C
FVR03	V <sub>FVR4</sub>	4x Gain (4.096V)	-5	—	+5	%	VDD≥4.75V, -40°C to 85°C
FVR04	T <sub>FVRST</sub>	FVR Start-up Time	—	60	—	μs	

#### 42.4.12 Zero-Cross Detect (ZCD) Specifications

Table 42-18.

Standard Operating Conditions (unless otherwise stated)							
$V_{DD} = 3.0V, T_A = 25^{\circ}C$							
Param No.	Sym.	Characteristic	Min.	Typ. †	Max.	Units	Conditions
ZC01	V <sub>PINZC</sub>	Voltage on Zero Cross Pin	—	0.75	—	V	
ZC02	I <sub>ZCD_MAX</sub>	Maximum source or sink current	—	—	600	μA	
ZC03	T <sub>RESPH</sub>	Response Time, Rising Edge	—	1	—	μs	
	T <sub>RESPL</sub>	Response Time, Falling Edge	—	1	—	μs	

† Data in “Typ” column is at 3.0V, 25°C unless otherwise stated. These parameters are for design guidance only and are not tested.

**42.4.13 Timer0 and Timer1 External Clock Requirements**

**Table 42-19.**

Standard Operating Conditions (unless otherwise stated)								
Operating Temperature: $-40^{\circ}\text{C} \leq T_A \leq +125^{\circ}\text{C}$								
Param No.	Sym.	Characteristic		Min.	Typ. †	Max.	Units	Conditions
40*	T <sub>T0H</sub>	T0CKI High Pulse Width	No Prescaler	0.5T <sub>CY</sub> +20	—	—	ns	
			With Prescaler	10	—	—	ns	
41*	T <sub>T0L</sub>	T0CKI Low Pulse Width	No Prescaler	0.5T <sub>CY</sub> +20	—	—	ns	
			With Prescaler	10	—	—	ns	
42*	T <sub>T0P</sub>	T0CKI Period		Greater of: 20 or (T <sub>CY</sub> +40)/N	—	—	ns	N = Prescale value
45*	T <sub>T1H</sub>	T1CKI High Time	Synchronous, No Prescaler	0.5T <sub>CY</sub> +20	—	—	ns	
			Synchronous, with Prescaler	15	—	—	ns	
			Asynchronous	30	—	—	ns	
46*	T <sub>T1L</sub>	T1CKI Low Time	Synchronous, No Prescaler	0.5T <sub>CY</sub> +20	—	—	ns	
			Synchronous, with Prescaler	15	—	—	ns	
			Asynchronous	30	—	—	ns	
47*	T <sub>T1P</sub>	T1CKI Input Period	Synchronous	Greater of: 30 or (T <sub>CY</sub> +40)/N	—	—	ns	N = Prescale value
			Asynchronous	60	—	—	ns	
49*	TCKEZ <sub>TMR1</sub>	Delay from External Clock Edge to Timer Increment		2 T <sub>OSC</sub>	—	7 T <sub>OSC</sub>	—	Timers in Sync mode

\* - These parameters are characterized but not tested.

† Data in "Typ" column is at 3.0V, 25°C unless otherwise stated. These parameters are for design guidance only and are not tested.

Figure 42-12. Timer0 and Timing1 External Clock Timings



42.4.14 Capture/Compare/PWM Requirements (CCP)

Table 42-20.

Standard Operating Conditions (unless otherwise stated)								
Operating Temperature: $-40^{\circ}\text{C} \leq T_A \leq +125^{\circ}\text{C}$								
Param No.	Sym.	Characteristic		Min.	Typ. †	Max.	Units	Conditions
CC01*	T <sub>CC</sub> L	CCPx Input Low Time	No Prescaler	$0.5T_{CY}+20$	—	—	ns	
			With Prescaler	20	—	—	ns	
CC02*	T <sub>CC</sub> H	CCPx Input High Time	No Prescaler	$0.5T_{CY}+20$	—	—	ns	
			With Prescaler	20	—	—	ns	
CC03*	T <sub>CC</sub> P	CCPx Input Period		$(3T_{CY}+40)/N$	—	—	ns	N = Prescale value

\* - These parameters are characterized but not tested.

† Data in “Typ” column is at 3.0V, 25°C unless otherwise stated. These parameters are for design guidance only and are not tested.

Figure 42-13. Capture/Compare/PWM Timings (CCP)



Note: Refer to Figure 42-4 for load conditions.

42.4.15 Configurable Logic Cell (CLC) Characteristics

Table 42-21.

Standard Operating Conditions (unless otherwise stated)								
Operating Temperature: $-40^{\circ}\text{C} \leq T_A \leq +125^{\circ}\text{C}$								
Param No.	Sym.	Characteristic		Min.	Typ. †	Max.	Units	Conditions
CLC01*	$T_{\text{CLCIN}}$	CLC input time		—	7	OS5	ns	(Note1)
CLC02*	$T_{\text{CLC}}$	CLC module input to output propagation time		—	24	—	ns	$V_{\text{DD}} = 1.8\text{V}$
				—	12	—	ns	$V_{\text{DD}} > 3.6\text{V}$
CLC03*	$T_{\text{CLCOUT}}$	CLC output time	Rise Time	—	OS7	—	—	(Note1)
			Fall Time	—	OS8	—	—	(Note1)
CLC04*	$F_{\text{CLCMAX}}$	CLC maximum switching frequency		—	32	$F_{\text{OSC}}$	MHz	

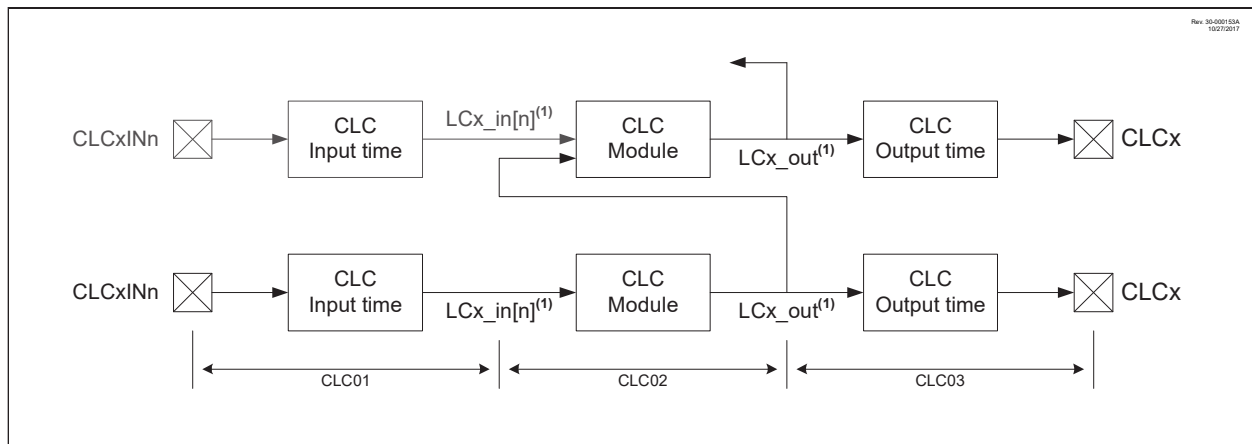
\* - These parameters are characterized but not tested.

† - Data in "Typ" column is at 3.0V, 25°C unless otherwise stated. These parameters are for design guidance only and are not tested.

**Note:**

- See "I/O and CLKOUT Timing Specifications" for OS5, OS7 and OS8 rise and fall times.

Figure 42-14. CLC Propagation Timing



Related Links

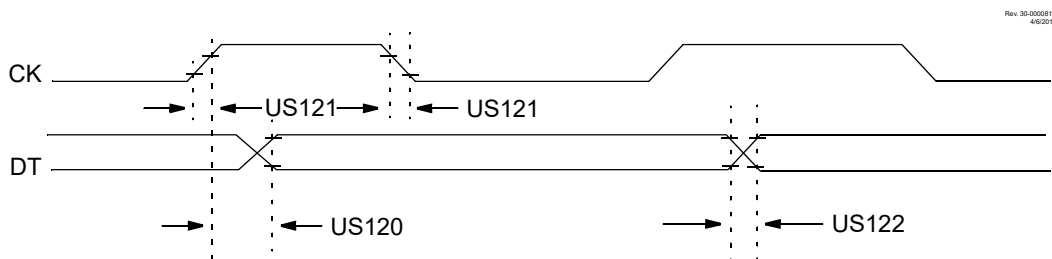
42.4.4 I/O and CLKOUT Timing Specifications

42.4.16 EUSART Synchronous Transmission Requirements

Table 42-22.

Standard Operating Conditions (unless otherwise stated)						
Param No.	Sym.	Characteristic	Min.	Max.	Units	Conditions
US120	$T_{CKH2DTV}$	SYNC XMIT (Master and Slave)	—	80	ns	$3.0V \leq V_{DD} \leq 5.5V$
		Clock high to data-out valid	—	100	ns	$1.8V \leq V_{DD} \leq 5.5V$
US121	$T_{CKRF}$	Clock out rise time and fall time (Master mode)	—	45	ns	$3.0V \leq V_{DD} \leq 5.5V$
			—	50	ns	$1.8V \leq V_{DD} \leq 5.5V$
US122	$T_{DTRF}$	Data-out rise time and fall time	—	45	ns	$3.0V \leq V_{DD} \leq 5.5V$
			—	50	ns	$1.8V \leq V_{DD} \leq 5.5V$

Figure 42-15. EUSART Synchronous Transmission (Master/Slave) Timing



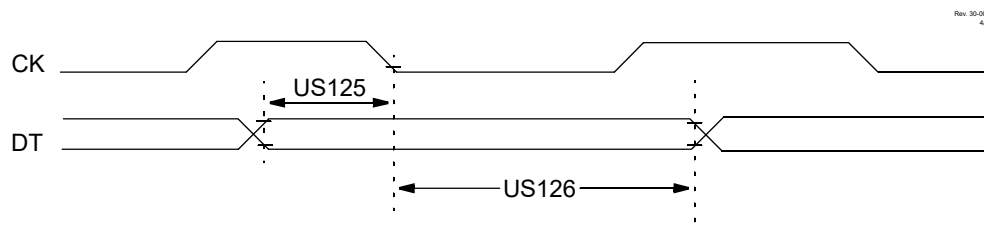
**Note:** Refer to Figure 42-4 for load conditions.

42.4.17 EUSART Synchronous Receive Requirements

Table 42-23.

Standard Operating Conditions (unless otherwise stated)						
Param No.	Sym.	Characteristic	Min.	Max.	Units	Conditions
US125	$T_{DTV2CKL}$	SYNC RCV (Master and Slave)	10	—	ns	
		Data-setup before CK ↓ (DT hold time)				
US126	$T_{CKL2DTL}$	Data-hold after CK ↓ (DT hold time)	15	—	ns	

Figure 42-16. EUSART Synchronous Receive (Master/Slave) Timing



**Note:** Refer to Figure 42-4 for load conditions.

42.4.18 SPI Mode Requirements

Table 42-24.

Standard Operating Conditions (unless otherwise stated)							
Param No.	Sym.	Characteristic	Min.	Typ. †	Max.	Units	Conditions
SP70*	$T_{SSL2_{SCKH}}$ , $T_{SSL2_{SCKL}}$	$\overline{SS}\downarrow$ to SCK $\downarrow$ or SCK $\uparrow$ input	$2.25 \cdot T_{CY}$	—	—	ns	
SP71*	$T_{SCKH}$	SCK input high time (Slave mode)	$T_{CY} + 20$	—	—	ns	
SP72*	$T_{SCKL}$	SCK input low time (Slave mode)	$T_{CY} + 20$	—	—	ns	
SP73*	$T_{DI}V2_{SCKH}$ , $T_{DI}V2_{SCKL}$	Setup time of SDI data input to SCK edge	100	—	—	ns	
SP74*	$T_{SCKH2_{DIL}}$ , $T_{SCKL2_{DIL}}$	Hold time of SDI data input to SCK edge	100	—	—	ns	
SP75*	$T_{DOR}$	SDO data output rise time	—	10	25	ns	$3.0V \leq V_{DD} \leq 5.5V$
			—	25	50	ns	$1.8V \leq V_{DD} \leq 5.5V$
SP76*	$T_{DOF}$	SDO data output fall time	—	10	25	ns	
SP77*	$T_{SSH2_{DOZ}}$	$\overline{SS}\uparrow$ to SDO output high-impedance	10	—	50	ns	
SP78*	$T_{SCKR}$	SCK output rise time (Master mode)	—	10	25	ns	$3.0V \leq V_{DD} \leq 5.5V$
			—	25	50	ns	$1.8V \leq V_{DD} \leq 5.5V$
SP79*	$T_{SCKF}$	SCK output fall time (Master mode)	—	10	25	ns	
SP80*	$T_{SCKH2_{DOV}}$ , $T_{SCKL2_{DOV}}$	SDO data output valid after SCK edge	—	—	50	ns	$3.0V \leq V_{DD} \leq 5.5V$
			—	—	145	ns	$1.8V \leq V_{DD} \leq 5.5V$
SP81*	$T_{DOV2_{SCKH}}$ , $T_{DOV2_{SCKL}}$	SDO data output setup to SCK edge	$1 T_{CY}$	—	—	ns	
SP82*	$T_{SSL2_{DOV}}$	SDO data output valid after $\overline{SS}\downarrow$ edge	—	—	50	ns	
SP83*	$T_{SCKH2_{SSH}}$ , $T_{SCKL2_{SSH}}$	$\overline{SS}\uparrow$ after SCK edge	$1.5 T_{CY}$ + 40	—	—	ns	

\* - These parameters are characterized but not tested.

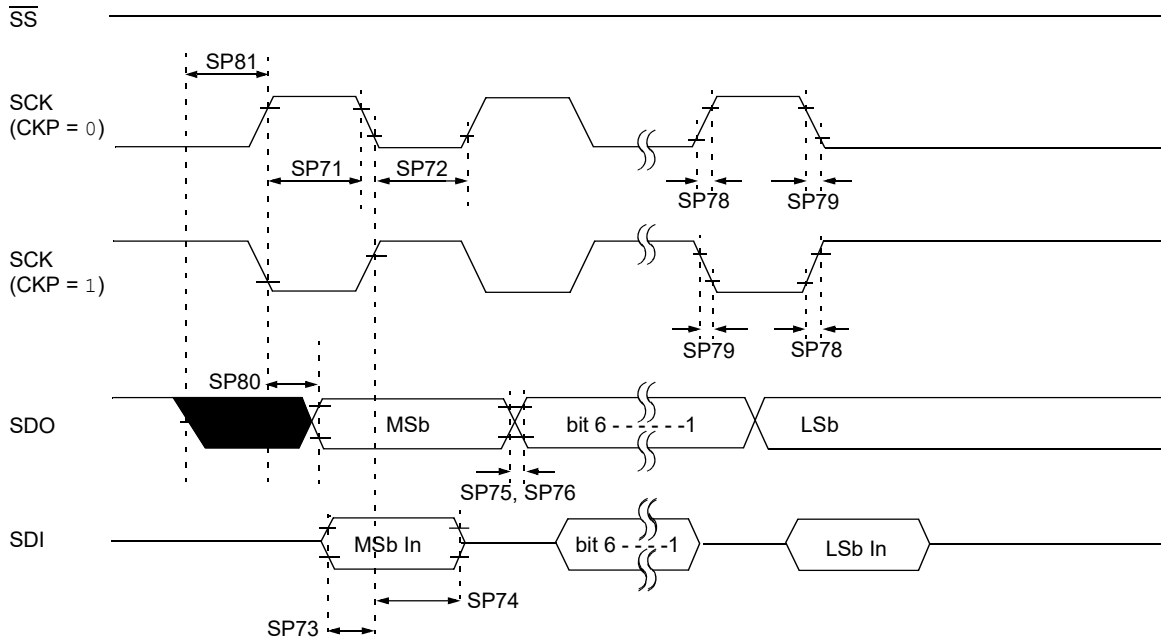
### Standard Operating Conditions (unless otherwise stated)

Param No.	Sym.	Characteristic	Min.	Typ. †	Max.	Units	Conditions
-----------	------	----------------	------	--------	------	-------	------------

† Data in "Typ" column is at 3.0V, 25°C unless otherwise stated. These parameters are for design guidance only and are not tested.

**Figure 42-17. SPI Master Mode Timing (CKE = 0, SMP = 0)**

Rev. 30-00085A  
4/8/2017

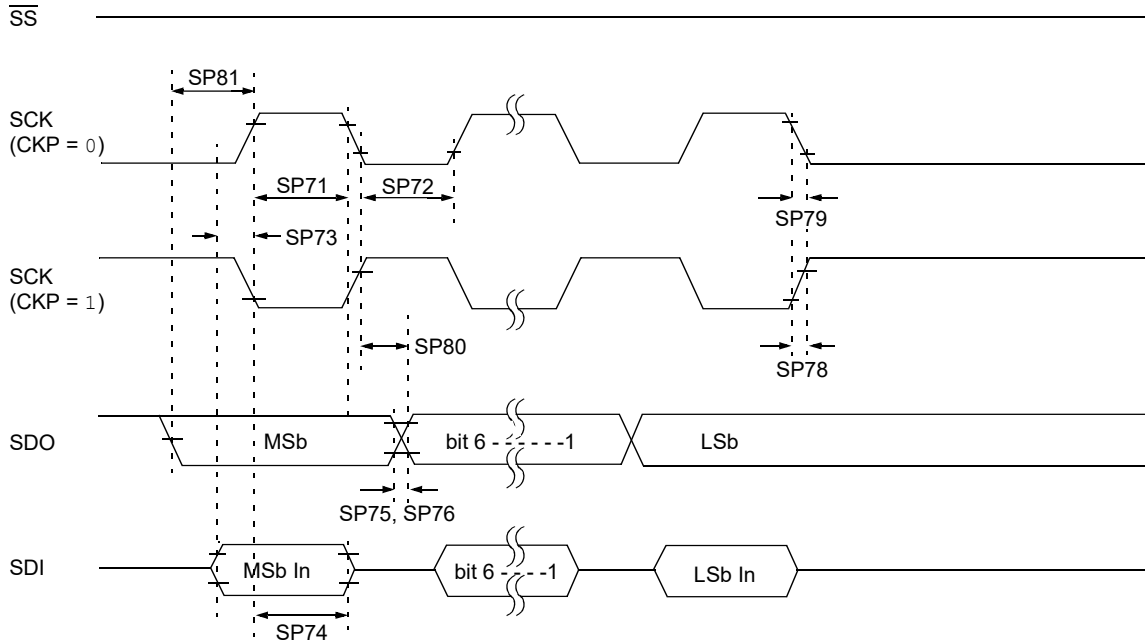


**Note:** Refer to [Figure 42-4](#) for load conditions.



Figure 42-18. SPI Master Mode Timing (CKE = 1, SMP = 1)

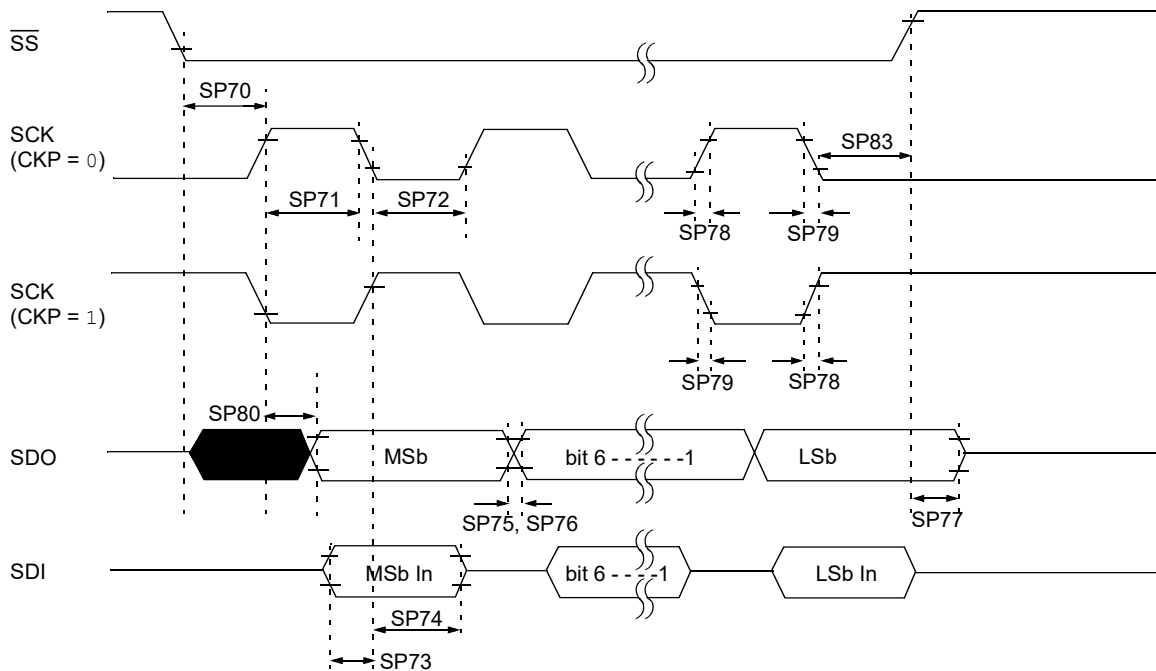
Rev. 30-00086A  
4/6/2017



**Note:** Refer to Figure 42-4 for load conditions.

Figure 42-19. SPI Slave Mode Timing (CKE = 0)

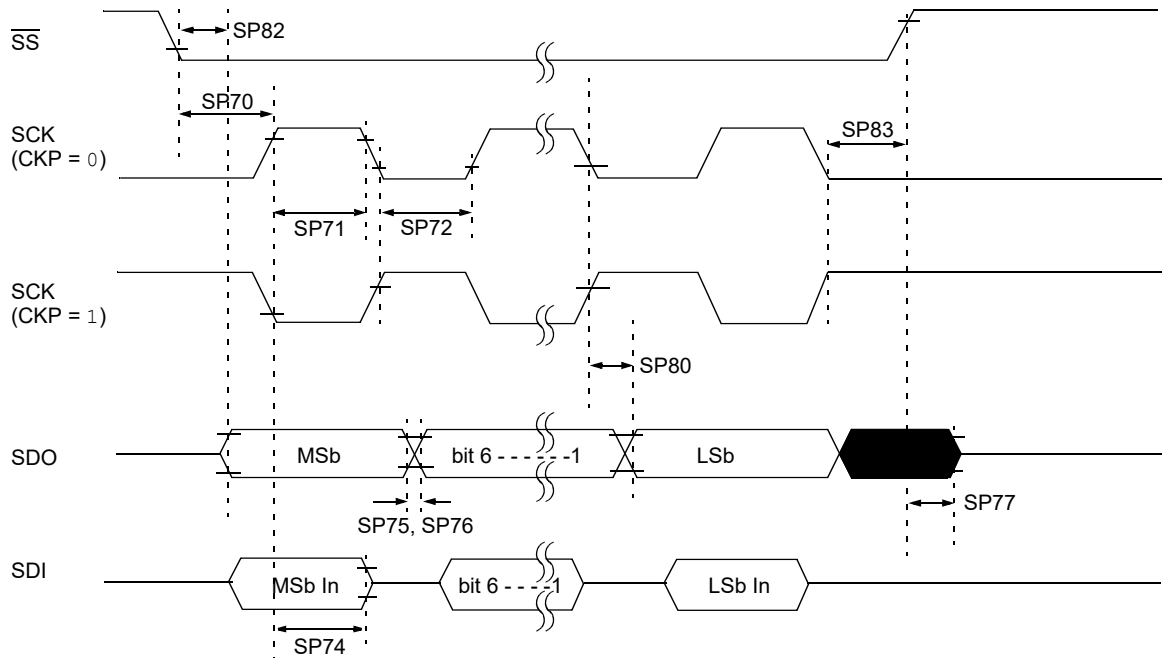
Rev. 30-00085A  
4/6/2017



**Note:** Refer to Figure 42-4 for load conditions.

Figure 42-20. SPI Slave Mode Timing (CKE = 1)

Rev. 33:00086A  
4/6/2017



Note: Refer to Figure 42-4 for load conditions.

#### 42.4.19 I<sup>2</sup>C Bus Start/Stop Bits Requirements

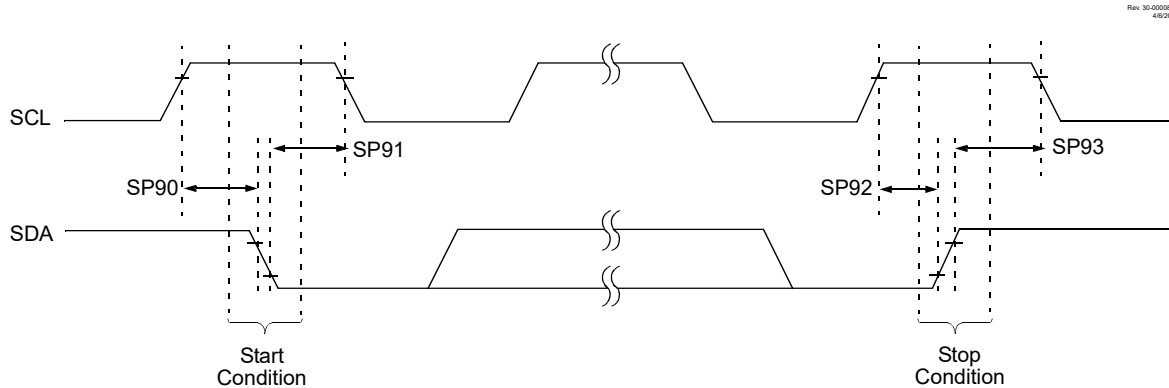
Table 42-25.

Standard Operating Conditions (unless otherwise stated)								
Param. No.	Sym.	Characteristic	Min.	Typ. †	Max.	Units	Conditions	
SP90*	$T_{SU:STA}$	Start condition Setup time	100 kHz mode	4700	—	—	ns	Only relevant for Repeated Start Setup time 400 kHz mode 600 condition
			400 kHz mode	600	—	—		
SP91*	$T_{HD:STA}$	Start condition Hold time	100 kHz mode	4000	—	—	ns	After this period, the first clock Hold time 400 kHz mode 600 — — pulse is generated
			400 kHz mode	600	—	—		
SP92*	$T_{SU:STO}$	Stop condition Setup time	100 kHz mode	4700	—	—	ns	
			400 kHz mode	600	—	—		
SP93*	$T_{HD:STO}$	Stop condition Hold time	100 kHz mode	4000	—	—	ns	

Standard Operating Conditions (unless otherwise stated)							
Param. No.	Sym.	Characteristic	Min.	Typ. †	Max.	Units	Conditions
		400 kHz mode	600	—	—		

\* - These parameters are characterized but not tested.

**Figure 42-21. I<sup>2</sup>C Bus Start/Stop Bits Timing**



**Note:** Refer to [Figure 42-4](#) for load conditions.

#### 42.4.20 I<sup>2</sup>C Bus Data Requirements

**Table 42-26.**

Standard Operating Conditions (unless otherwise stated)							
Param. No.	Sym.	Characteristic	Min.	Max.	Units	Conditions	
SP100*	T <sub>HIGH</sub>	Clock high time	100 kHz mode	4.0	—	μs	Device must operate at a minimum of 1.5 MHz
			400 kHz mode	0.6	—	μs	Device must operate at a minimum of 10 MHz
			SSP module	1.5T <sub>CY</sub>	—		
SP101*	T <sub>LOW</sub>	Clock low time	100 kHz mode	4.7	—	μs	Device must operate at a minimum of 1.5 MHz
			400 kHz mode	1.3	—	μs	Device must operate at a minimum of 10 MHz

# PIC16(L)F18455/56

## Electrical Specifications

Standard Operating Conditions (unless otherwise stated)							
Param. No.	Sym.	Characteristic		Min.	Max.	Units	Conditions
			SSP module	$1.5T_{CY}$	—		
SP102*	$T_R$	SDA and SCL rise time	100 kHz mode	—	1000	ns	$C_B$ is specified to be from 10-400 pF
			400 kHz mode	$20 + 0.1C_B$	300	ns	
SP103*	$T_F$	SDA and SCL fall time	100 kHz mode	—	250	ns	$C_B$ is specified to be from 10-400 pF
			400 kHz mode	$20 + 0.1C_B$	250	ns	
SP106*	$T_{HD:DAT}$	Data input hold time	100 kHz mode	0	—	ns	
			400 kHz mode	0	0.9	$\mu s$	
SP107*	$T_{SU:DAT}$	Data input setup time	100 kHz mode	250	—	ns	<b>(Note 2)</b>
			400 kHz mode	100	—	ns	
SP109*	$T_{AA}$	Output valid from clock	100 kHz mode	—	3500	ns	<b>(Note 1)</b>
			400 kHz mode	—	—	ns	
SP110*	$T_{BUF}$	Bus free time	100 kHz mode	4.7	—	$\mu s$	Time the bus must be free before a new transmission can start
			400 kHz mode	1.3	—	$\mu s$	
SP111	$C_B$	Bus capacitive loading		—	400	pF	

\* - These parameters are characterized but not tested.

### Note:

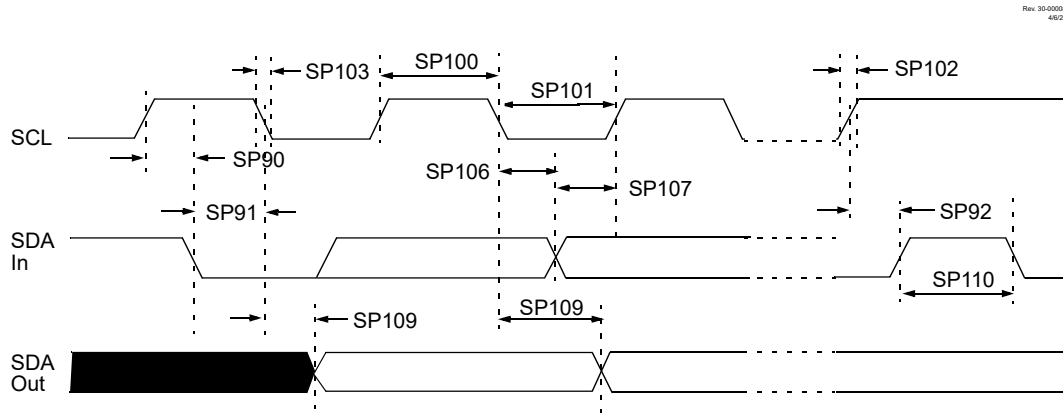
- As a transmitter, the device must provide this internal minimum delay time to bridge the undefined region (min. 300 ns) of the falling edge of SCL to avoid unintended generation of Start or Stop conditions.
- A Fast mode (400 kHz) I<sup>2</sup>C bus device can be used in a Standard mode (100 kHz) I<sup>2</sup>C bus system, but the requirement  $T_{SU:DAT} \geq 250$  ns must then be met. This will automatically be the case

**Standard Operating Conditions (unless otherwise stated)**

Param. No.	Sym.	Characteristic	Min.	Max.	Units	Conditions
------------	------	----------------	------	------	-------	------------

if the device does not stretch the low period of the SCL signal. If such a device does stretch the low period of the SCL signal, it must output the next data bit to the SDA line  $T_{R\max} + T_{SU:DAT} = 1000 + 250 = 1250$  ns (according to the Standard mode I<sup>2</sup>C bus specification), before the SCL line is released.

**Figure 42-22. I<sup>2</sup>C Bus Data Timing**



**Note:** Refer to [Figure 42-4](#) for load conditions.

### 43. DC and AC Characteristics Graphs and Tables

The graphs and tables provided in this section are for design guidance and are not tested. In some graphs or tables, the data presented are outside specified operating range (i.e., outside specified  $V_{DD}$  range). This is for information only and devices are ensured to operate properly only within the specified range. Unless otherwise noted, all graphs apply to both the L and LF devices.

**Note:**

The graphs and tables provided following this note are a statistical summary based on a limited number of samples and are provided for informational purposes only. The performance characteristics listed herein are not tested or guaranteed. In some graphs or tables, the data presented may be outside the specified operating range (e.g., outside specified power supply range) and therefore, outside the warranted range.

**Note:**

“Typical” represents the mean of the distribution at 25°C. “Maximum”, “Max.”, “Minimum” or “Min.” represents (mean +  $3\sigma$ ) or (mean -  $3\sigma$ ) respectively, where  $\sigma$  is a standard deviation, over each temperature range.

43.1 Graphs

Figure 43-1. High Range Temperature Indicator Voltage Sensitivity Across Temperature

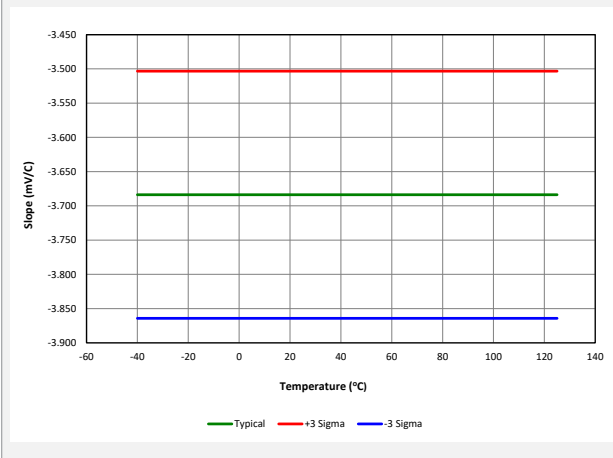
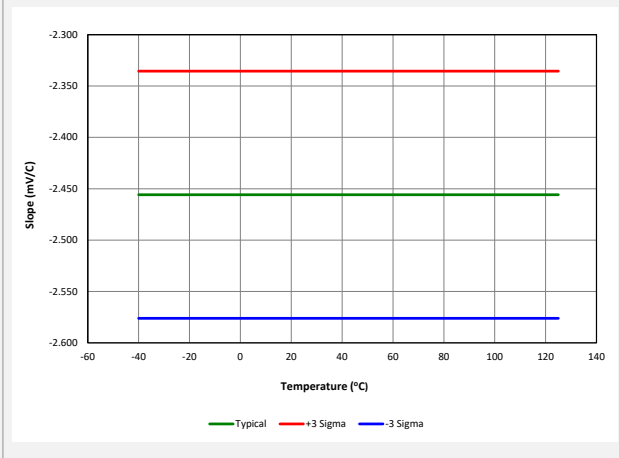


Figure 43-2. Low Range Temperature Indicator Voltage Sensitivity Across Temperature



## 44. Packaging Information

### Package Marking Information

Rev. 30-009000A  
5/17/2017

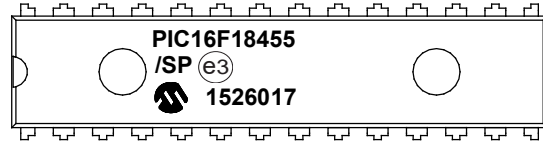
<b>Legend:</b>	XX...X	Customer-specific information or Microchip part number
	Y	Year code (last digit of calendar year)
	YY	Year code (last 2 digits of calendar year)
	WW	Week code (week of January 1 is week '01')
	NNN	Alphanumeric traceability code
	(e3)	b-free JEDEC <sup>®</sup> designator for Matte Tin (Sn)
	*	This package is Pb-free. The Pb-free JEDEC designator ((e3)) can be found on the outer packaging for this package.

**Note:** In the event the full Microchip part number cannot be marked on one line, it will be carried over to the next line, thus limiting the number of available characters for customer-specific information.

28-Lead SPDIP (.300")



Example

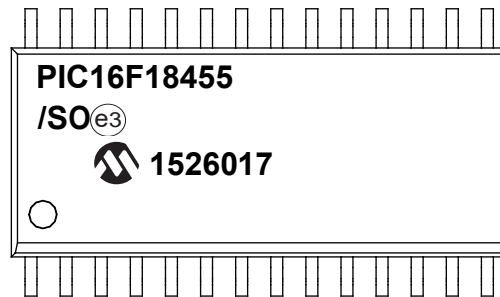


Rev. 30-009028A  
5/17/2017

28-Lead SOIC (7.50 mm)



Example



Rev. 30-009028B  
5/17/2017

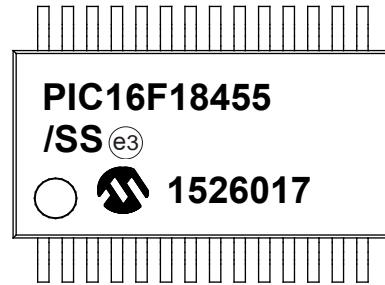


Rev. 30-009028C  
 5/17/2017

28-Lead SSOP (5.30 mm)

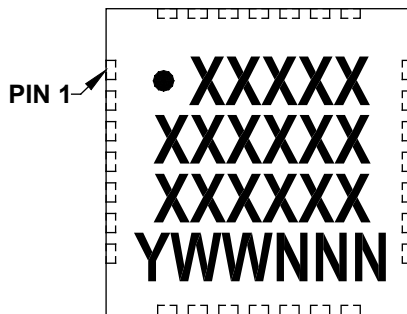


Example

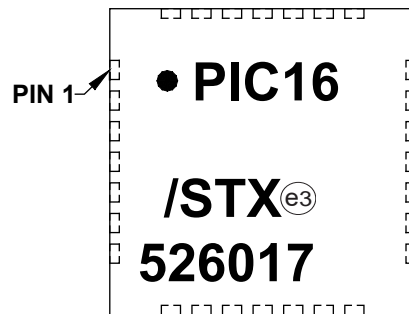


Rev. 30-009028F  
 4/2/2016

28-Lead VQFN (4x4x1 mm)



Example



#### 44.1 Package Details

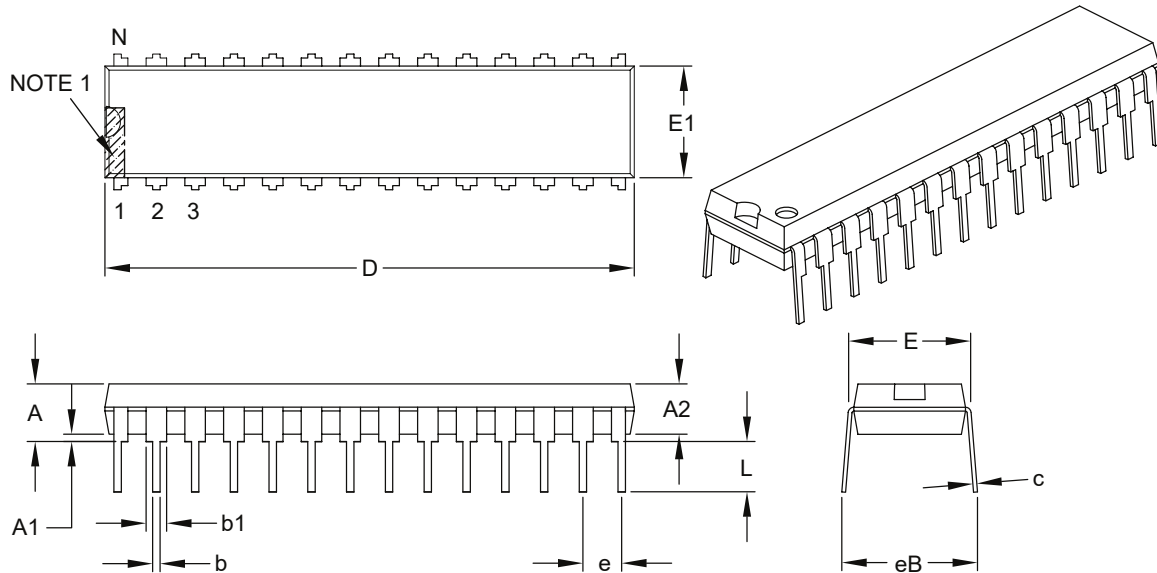
The following sections give the technical details of the packages.

# PIC16(L)F18455/56

## Packaging Information

### 28-Lead Skinny Plastic Dual In-Line (SP) – 300 mil Body [SPDIP]

**Note:** For the most current package drawings, please see the Microchip Packaging Specification located at <http://www.microchip.com/packaging>



Dimension Limits	Units	INCHES		
		MIN	NOM	MAX
Number of Pins	N	28		
Pitch	e	.100 BSC		
Top to Seating Plane	A	–	–	.200
Molded Package Thickness	A2	.120	.135	.150
Base to Seating Plane	A1	.015	–	–
Shoulder to Shoulder Width	E	.290	.310	.335
Molded Package Width	E1	.240	.285	.295
Overall Length	D	1.345	1.365	1.400
Tip to Seating Plane	L	.110	.130	.150
Lead Thickness	c	.008	.010	.015
Upper Lead Width	b1	.040	.050	.070
Lower Lead Width	b	.014	.018	.022
Overall Row Spacing §	eB	–	–	.430

**Notes:**

1. Pin 1 visual index feature may vary, but must be located within the hatched area.
2. § Significant Characteristic.
3. Dimensions D and E1 do not include mold flash or protrusions. Mold flash or protrusions shall not exceed .010" per side.
4. Dimensioning and tolerancing per ASME Y14.5M.

BSC: Basic Dimension. Theoretically exact value shown without tolerances.

Microchip Technology Drawing C04-070B

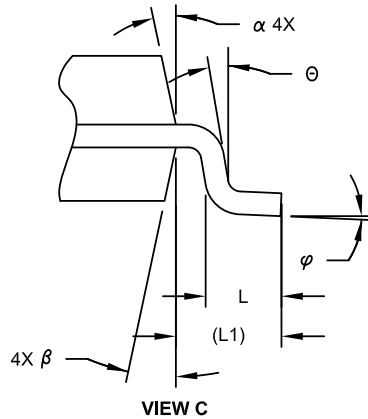


# PIC16(L)F18455/56

## Packaging Information

### 28-Lead Plastic Small Outline (SO) - Wide, 7.50 mm Body [SOIC]

**Note:** For the most current package drawings, please see the Microchip Packaging Specification located at <http://www.microchip.com/packaging>



Units		MILLIMETERS		
Dimension	Limits	MIN	NOM	MAX
Number of Pins	N	28		
Pitch	e	1.27 BSC		
Overall Height	A	-	-	2.65
Molded Package Thickness	A2	2.05	-	-
Standoff §	A1	0.10	-	0.30
Overall Width	E	10.30 BSC		
Molded Package Width	E1	7.50 BSC		
Overall Length	D	17.90 BSC		
Chamfer (Optional)	h	0.25	-	0.75
Foot Length	L	0.40	-	1.27
Footprint	L1	1.40 REF		
Lead Angle	$\theta$	0°	-	-
Foot Angle	$\varphi$	0°	-	8°
Lead Thickness	c	0.18	-	0.33
Lead Width	b	0.31	-	0.51
Mold Draft Angle Top	$\alpha$	5°	-	15°
Mold Draft Angle Bottom	$\beta$	5°	-	15°

**Notes:**

- Pin 1 visual index feature may vary, but must be located within the hatched area.
- § Significant Characteristic
- Dimension D does not include mold flash, protrusions or gate burrs, which shall not exceed 0.15 mm per end. Dimension E1 does not include interlead flash or protrusion, which shall not exceed 0.25 mm per side.
- Dimensioning and tolerancing per ASME Y14.5M
  - BSC: Basic Dimension, Theoretically exact value shown without tolerances.
  - REF: Reference Dimension, usually without tolerance, for information purposes only.
- Datums A & B to be determined at Datum H.

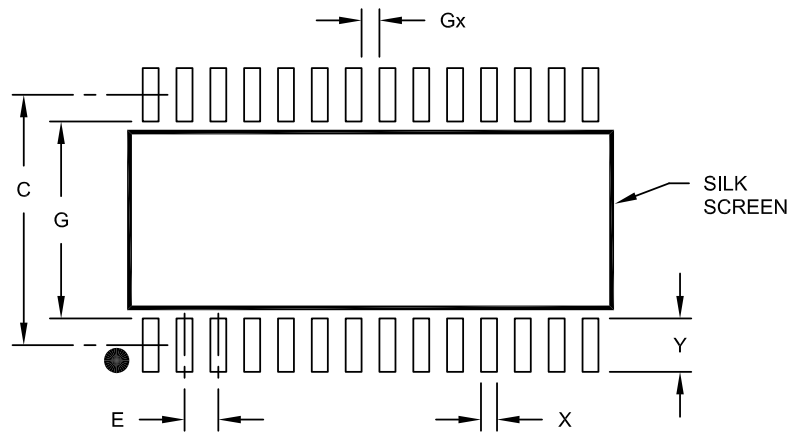
Microchip Technology Drawing C04-052C Sheet 2 of 2

# PIC16(L)F18455/56

## Packaging Information

28-Lead Plastic Small Outline (SO) - Wide, 7.50 mm Body [SOIC]

**Note:** For the most current package drawings, please see the Microchip Packaging Specification located at <http://www.microchip.com/packaging>



RECOMMENDED LAND PATTERN

Dimension Limits	Units	MILLIMETERS		
		MIN	NOM	MAX
Contact Pitch	E	1.27 BSC		
Contact Pad Spacing	C		9.40	
Contact Pad Width (X28)	X			0.60
Contact Pad Length (X28)	Y			2.00
Distance Between Pads	Gx	0.67		
Distance Between Pads	G	7.40		

Notes:

1. Dimensioning and tolerancing per ASME Y14.5M

BSC: Basic Dimension. Theoretically exact value shown without tolerances.

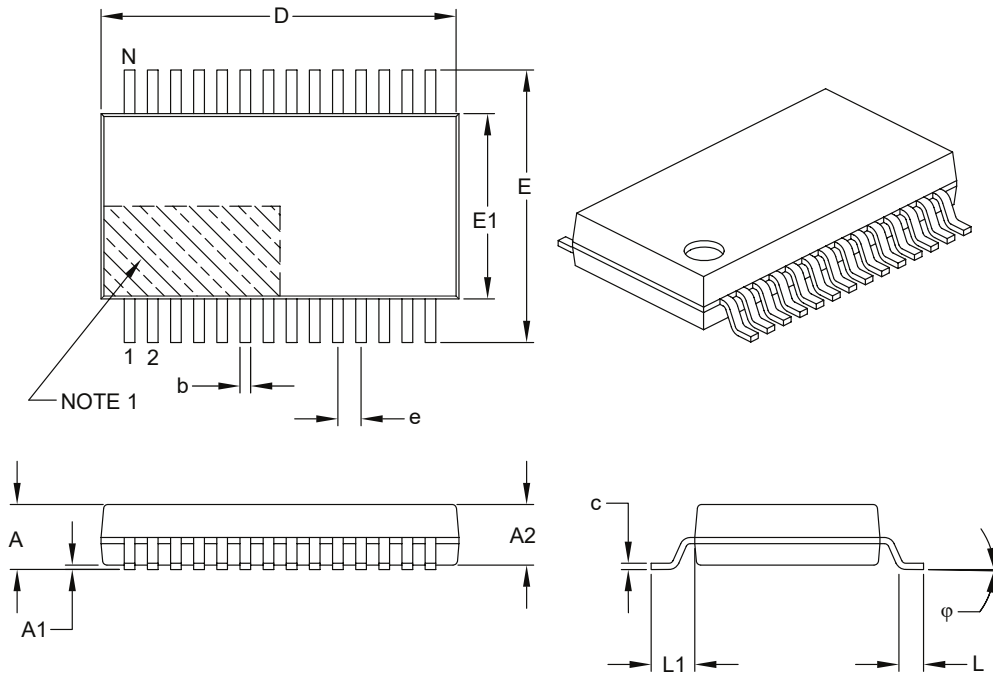
Microchip Technology Drawing No. C04-2052A

# PIC16(L)F18455/56

## Packaging Information

### 28-Lead Plastic Shrink Small Outline (SS) – 5.30 mm Body [SSOP]

**Note:** For the most current package drawings, please see the Microchip Packaging Specification located at <http://www.microchip.com/packaging>



Dimension Limits	Units	MILLIMETERS		
		MIN	NOM	MAX
Number of Pins	N	28		
Pitch	e	0.65 BSC		
Overall Height	A	–	–	2.00
Molded Package Thickness	A2	1.65	1.75	1.85
Standoff	A1	0.05	–	–
Overall Width	E	7.40	7.80	8.20
Molded Package Width	E1	5.00	5.30	5.60
Overall Length	D	9.90	10.20	10.50
Foot Length	L	0.55	0.75	0.95
Footprint	L1	1.25 REF		
Lead Thickness	c	0.09	–	0.25
Foot Angle	φ	0°	4°	8°
Lead Width	b	0.22	–	0.38

**Notes:**

- Pin 1 visual index feature may vary, but must be located within the hatched area.
- Dimensions D and E1 do not include mold flash or protrusions. Mold flash or protrusions shall not exceed 0.20 mm per side.
- Dimensioning and tolerancing per ASME Y14.5M.

BSC: Basic Dimension. Theoretically exact value shown without tolerances.

REF: Reference Dimension, usually without tolerance, for information purposes only.

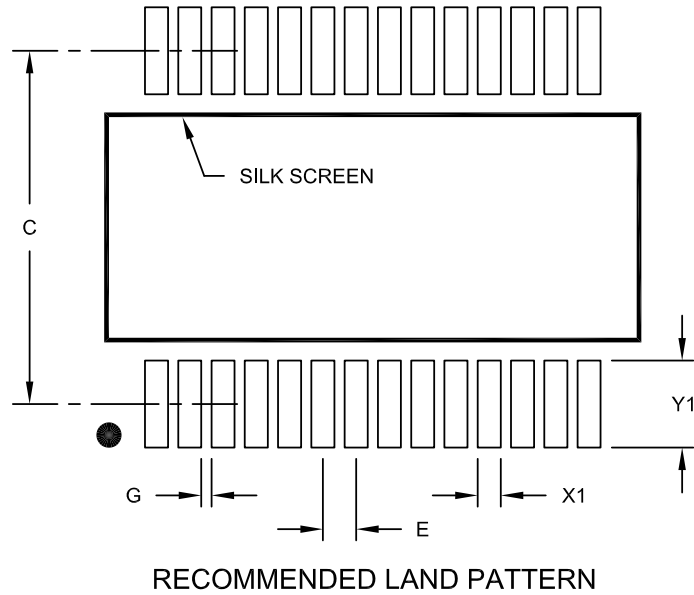
Microchip Technology Drawing C04-073B

# PIC16(L)F18455/56

## Packaging Information

28-Lead Plastic Shrink Small Outline (SS) - 5.30 mm Body [SSOP]

**Note:** For the most current package drawings, please see the Microchip Packaging Specification located at <http://www.microchip.com/packaging>



Dimension Limits	Units	MILLIMETERS		
		MIN	NOM	MAX
Contact Pitch	E	0,65 BSC		
Contact Pad Spacing	C		7,20	
Contact Pad Width (X28)	X1			0,45
Contact Pad Length (X28)	Y1			1,75
Distance Between Pads	G	0,20		

Notes:

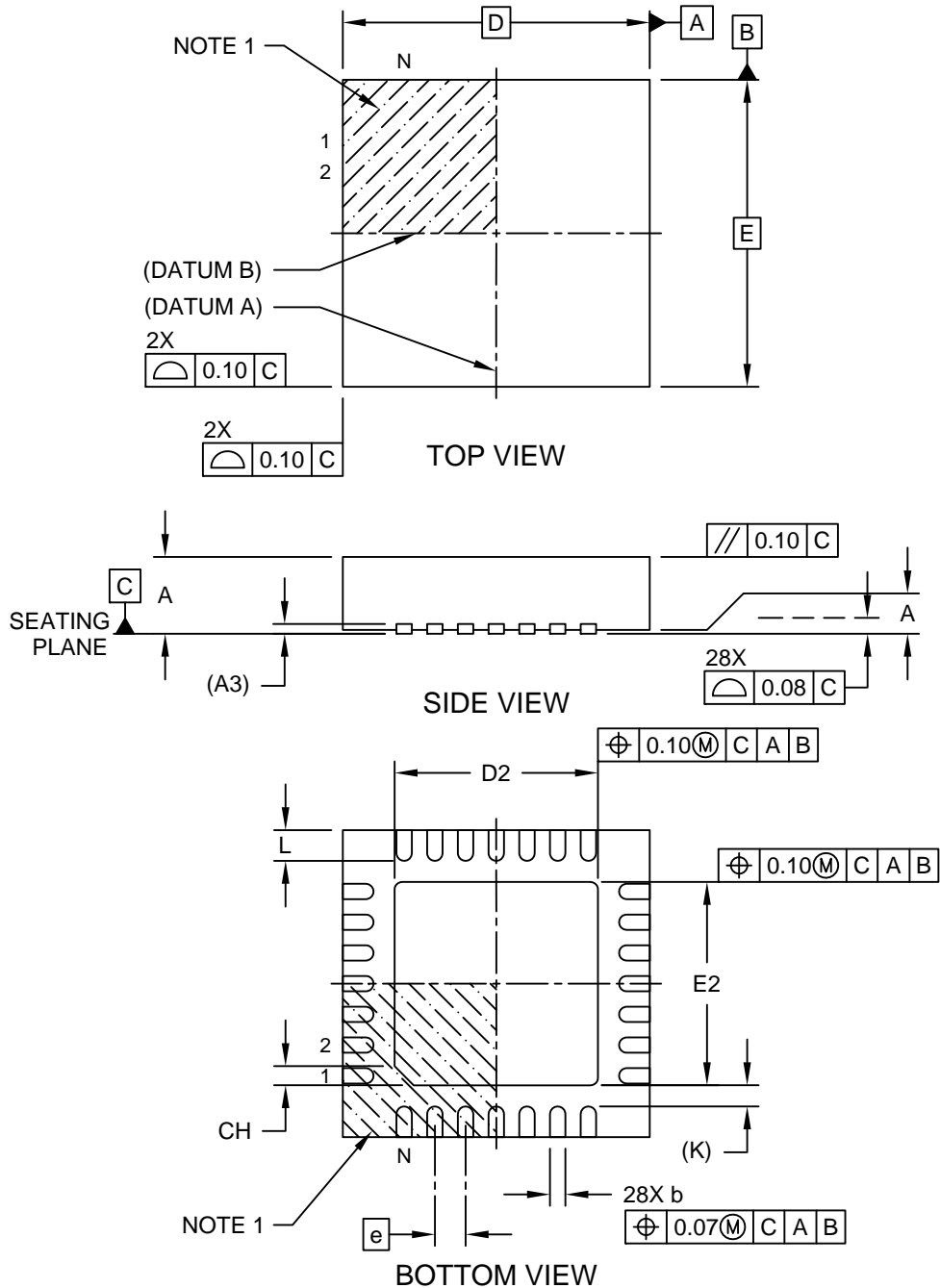
1. Dimensioning and tolerancing per ASME Y14.5M

BSC: Basic Dimension. Theoretically exact value shown without tolerances.

Microchip Technology Drawing No. C04-2073A

**28-Lead Very Thin Plastic Quad Flat, No Lead (STX) - 4x4 mm Body [VQFN]  
With 2.65x2.65 mm Exposed Pad**

**Note:** For the most current package drawings, please see the Microchip Packaging Specification located at <http://www.microchip.com/packaging>

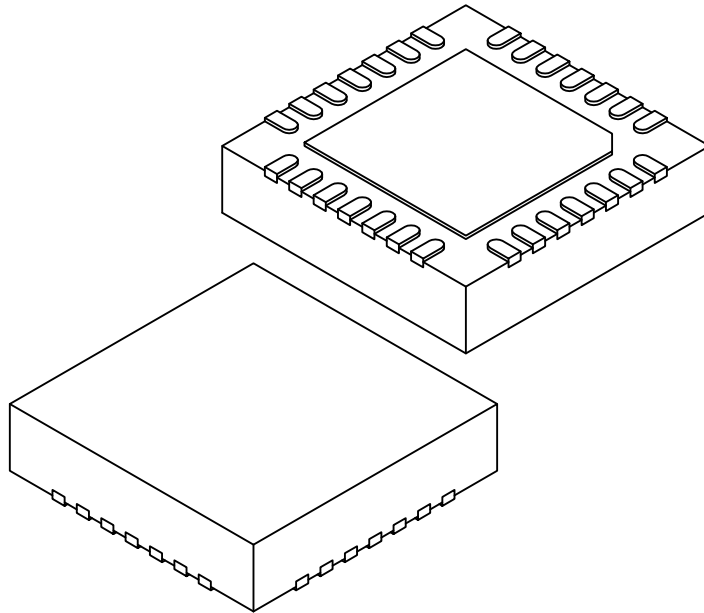


Microchip Technology Drawing C04-456 Rev A Sheet 1 of 2



**28-Lead Very Thin Plastic Quad Flat, No Lead (STX) - 4x4 mm Body [VQFN]  
 With 2.65x2.65 mm Exposed Pad**

**Note:** For the most current package drawings, please see the Microchip Packaging Specification located at <http://www.microchip.com/packaging>



Dimension Limits	Units	MILLIMETERS		
		MIN	NOM	MAX
Number of Terminals	N	28		
Pitch	e	0.40 BSC		
Overall Height	A	0.80	0.90	1.00
Standoff	A1	0.00	0.02	0.05
Terminal Thickness	A3	0.127 REF		
Overall Length	D	4.00 BSC		
Exposed Pad Length	D2	2.55	2.65	2.75
Overall Width	E	4.00 BSC		
Exposed Pad Width	E2	2.55	2.65	2.75
Exposed Pad Corner Chamfer	CH	-	0.25	-
Terminal Width	b	0.15	0.20	0.25
Terminal Length	L	0.30	0.40	0.50
Terminal-to-Exposed-Pad	K	0.275 REF		

**Notes:**

1. Pin 1 visual index feature may vary, but must be located within the hatched area.
2. Package is saw singulated
3. Dimensioning and tolerancing per ASME Y14.5M

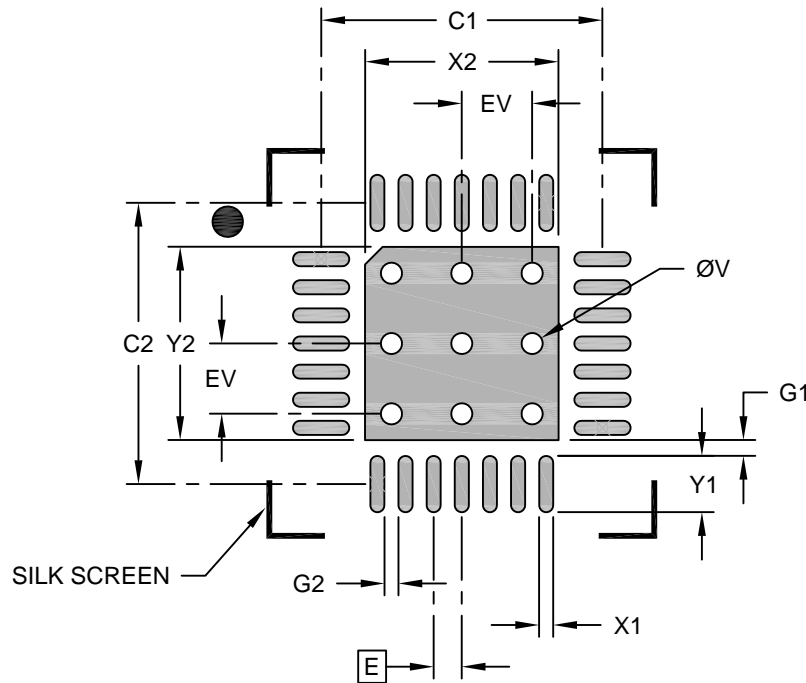
BSC: Basic Dimension. Theoretically exact value shown without tolerances.

REF: Reference Dimension, usually without tolerance, for information purposes only.

Microchip Technology Drawing C04-456 Rev A Sheet 2 of 2

28-Lead Very Thin Plastic Quad Flat, No Lead (STX) - 4x4 mm Body [VQFN]  
With 2.65x2.65 mm Exposed Pad

**Note:** For the most current package drawings, please see the Microchip Packaging Specification located at <http://www.microchip.com/packaging>



RECOMMENDED LAND PATTERN

Dimension Limits	Units	MILLIMETERS		
		MIN	NOM	MAX
Contact Pitch	E	0.40 BSC		
Optional Center Pad Width	X2			2.75
Optional Center Pad Length	Y2			2.75
Contact Pad Spacing	C1		4.00	
Contact Pad Spacing	C2		4.00	
Contact Pad Width (X28)	X1			0.20
Contact Pad Length (X28)	Y1			0.80
Contact Pad to Center Pad (X28)	G1	0.23		
Contact Pad to Contact Pad (X24)	G2	0.20		
Thermal Via Diameter	V		0.30	
Thermal Via Pitch	EV		1.00	

Notes:

1. Dimensioning and tolerancing per ASME Y14.5M  
BSC: Basic Dimension. Theoretically exact value shown without tolerances.
2. For best soldering results, thermal vias, if used, should be filled or tented to avoid solder loss during reflow process

Microchip Technology Drawing C04-2456 Rev A

**45. Revision History**

Date	Revision	Comment
5/2018	A	Initial release of this document.
6/2018	B	Minor corrections to electrical specs and removed EOL packages QFN and UQFN.

## The Microchip Web Site

---

Microchip provides online support via our web site at <http://www.microchip.com/>. This web site is used as a means to make files and information easily available to customers. Accessible by using your favorite Internet browser, the web site contains the following information:

- **Product Support** – Data sheets and errata, application notes and sample programs, design resources, user's guides and hardware support documents, latest software releases and archived software
- **General Technical Support** – Frequently Asked Questions (FAQ), technical support requests, online discussion groups, Microchip consultant program member listing
- **Business of Microchip** – Product selector and ordering guides, latest Microchip press releases, listing of seminars and events, listings of Microchip sales offices, distributors and factory representatives

## Customer Change Notification Service

---

Microchip's customer notification service helps keep customers current on Microchip products. Subscribers will receive e-mail notification whenever there are changes, updates, revisions or errata related to a specified product family or development tool of interest.

To register, access the Microchip web site at <http://www.microchip.com/>. Under "Support", click on "Customer Change Notification" and follow the registration instructions.

## Customer Support

---

Users of Microchip products can receive assistance through several channels:

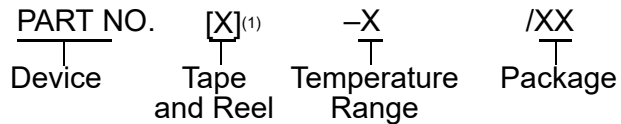
- Distributor or Representative
- Local Sales Office
- Field Application Engineer (FAE)
- Technical Support

Customers should contact their distributor, representative or Field Application Engineer (FAE) for support. Local sales offices are also available to help customers. A listing of sales offices and locations is included in the back of this document.

Technical support is available through the web site at: <http://www.microchip.com/support>

## Product Identification System

To order or obtain information, e.g., on pricing or delivery, refer to the factory or the listed sales office.



Device:	PIC16F18455, PIC16LF1845, PIC16F18456, PIC16LF18456	
Tape & Reel Option:	Blank	= Tube
	T	= Tape & Reel
Temperature Range:	I	= -40°C to +85°C (Industrial)
	E	= -40°C to +125°C (Extended)
Package:	SP	= 28-lead, SPDIP
	SO	= 28-lead SOIC
	SS	= 28-lead SSOP
	STX	= 28-lead VQFN 4x4x1 mm
Pattern:	QTP, SQTP, Code or Special Requirements (blank otherwise)	

Examples:

- PIC16F18455- E/P Extended temperature PDIP package

### Note:

1. Tape and Reel identifier only appears in the catalog part number description. This identifier is used for ordering purposes and is not printed on the device package. Check with your Microchip Sales Office for package availability with the Tape and Reel option.
2. Small form-factor packaging options may be available. Please check <http://www.microchip.com/packaging> for small-form factor package availability, or contact your local Sales Office.

## Microchip Devices Code Protection Feature

Note the following details of the code protection feature on Microchip devices:

- Microchip products meet the specification contained in their particular Microchip Data Sheet.
- Microchip believes that its family of products is one of the most secure families of its kind on the market today, when used in the intended manner and under normal conditions.
- There are dishonest and possibly illegal methods used to breach the code protection feature. All of these methods, to our knowledge, require using the Microchip products in a manner outside the operating specifications contained in Microchip's Data Sheets. Most likely, the person doing so is engaged in theft of intellectual property.
- Microchip is willing to work with the customer who is concerned about the integrity of their code.
- Neither Microchip nor any other semiconductor manufacturer can guarantee the security of their code. Code protection does not mean that we are guaranteeing the product as "unbreakable."

Code protection is constantly evolving. We at Microchip are committed to continuously improving the code protection features of our products. Attempts to break Microchip's code protection feature may be a violation of the Digital Millennium Copyright Act. If such acts allow unauthorized access to your software or other copyrighted work, you may have a right to sue for relief under that Act.

## Legal Notice

---

Information contained in this publication regarding device applications and the like is provided only for your convenience and may be superseded by updates. It is your responsibility to ensure that your application meets with your specifications. MICROCHIP MAKES NO REPRESENTATIONS OR WARRANTIES OF ANY KIND WHETHER EXPRESS OR IMPLIED, WRITTEN OR ORAL, STATUTORY OR OTHERWISE, RELATED TO THE INFORMATION, INCLUDING BUT NOT LIMITED TO ITS CONDITION, QUALITY, PERFORMANCE, MERCHANTABILITY OR FITNESS FOR PURPOSE. Microchip disclaims all liability arising from this information and its use. Use of Microchip devices in life support and/or safety applications is entirely at the buyer's risk, and the buyer agrees to defend, indemnify and hold harmless Microchip from any and all damages, claims, suits, or expenses resulting from such use. No licenses are conveyed, implicitly or otherwise, under any Microchip intellectual property rights unless otherwise stated.

## Trademarks

---

The Microchip name and logo, the Microchip logo, AnyRate, AVR, AVR logo, AVR Freaks, BeaconThings, BitCloud, CryptoMemory, CryptoRF, dsPIC, FlashFlex, flexPWR, Heldo, JukeBlox, KeeLoq, KeeLoq logo, Klear, LANCheck, LINK MD, maXStylus, maXTouch, MediaLB, megaAVR, MOST, MOST logo, MPLAB, OptoLyzer, PIC, picoPower, PICSTART, PIC32 logo, Prochip Designer, QTouch, RightTouch, SAM-BA, SpyNIC, SST, SST Logo, SuperFlash, tinyAVR, UNI/O, and XMEGA are registered trademarks of Microchip Technology Incorporated in the U.S.A. and other countries.

ClockWorks, The Embedded Control Solutions Company, EtherSynch, Hyper Speed Control, HyperLight Load, IntelliMOS, mTouch, Precision Edge, and Quiet-Wire are registered trademarks of Microchip Technology Incorporated in the U.S.A.

Adjacent Key Suppression, AKS, Analog-for-the-Digital Age, Any Capacitor, AnyIn, AnyOut, BodyCom, chipKIT, chipKIT logo, CodeGuard, CryptoAuthentication, CryptoCompanion, CryptoController, dsPICDEM, dsPICDEM.net, Dynamic Average Matching, DAM, ECAN, EtherGREEN, In-Circuit Serial Programming, ICSP, Inter-Chip Connectivity, JitterBlocker, KlearNet, KlearNet logo, Mindi, MiWi, motorBench, MPASM, MPF, MPLAB Certified logo, MPLIB, MPLINK, MultiTRAK, NetDetach, Omniscient Code Generation, PICDEM, PICDEM.net, PICkit, PICtail, PureSilicon, QMatrix, RightTouch logo, REAL ICE, Ripple Blocker, SAM-ICE, Serial Quad I/O, SMART-I.S., SQI, SuperSwitcher, SuperSwitcher II, Total Endurance, TSHARC, USBCheck, VariSense, ViewSpan, WiperLock, Wireless DNA, and ZENA are trademarks of Microchip Technology Incorporated in the U.S.A. and other countries.

SQTP is a service mark of Microchip Technology Incorporated in the U.S.A.

Silicon Storage Technology is a registered trademark of Microchip Technology Inc. in other countries.

GestIC is a registered trademark of Microchip Technology Germany II GmbH & Co. KG, a subsidiary of Microchip Technology Inc., in other countries.

All other trademarks mentioned herein are property of their respective companies.

© 2018, Microchip Technology Incorporated, Printed in the U.S.A., All Rights Reserved.

ISBN: 978-1-5224-3260-9

## Quality Management System Certified by DNV

---

### ISO/TS 16949

Microchip received ISO/TS-16949:2009 certification for its worldwide headquarters, design and wafer fabrication facilities in Chandler and Tempe, Arizona; Gresham, Oregon and design centers in California and India. The Company's quality system processes and procedures are for its PIC<sup>®</sup> MCUs and dsPIC<sup>®</sup> DSCs, KEELOQ<sup>®</sup> code hopping devices, Serial EEPROMs, microperipherals, nonvolatile memory and analog products. In addition, Microchip's quality system for the design and manufacture of development systems is ISO 9001:2000 certified.

## Worldwide Sales and Service

AMERICAS	ASIA/PACIFIC	ASIA/PACIFIC	EUROPE
<p><b>Corporate Office</b> 2355 West Chandler Blvd. Chandler, AZ 85224-6199 Tel: 480-792-7200 Fax: 480-792-7277 Technical Support: <a href="http://www.microchip.com/support">http://www.microchip.com/support</a> Web Address: <a href="http://www.microchip.com">www.microchip.com</a></p> <p><b>Atlanta</b> Duluth, GA Tel: 678-957-9614 Fax: 678-957-1455</p> <p><b>Austin, TX</b> Tel: 512-257-3370</p> <p><b>Boston</b> Westborough, MA Tel: 774-760-0087 Fax: 774-760-0088</p> <p><b>Chicago</b> Itasca, IL Tel: 630-285-0071 Fax: 630-285-0075</p> <p><b>Dallas</b> Addison, TX Tel: 972-818-7423 Fax: 972-818-2924</p> <p><b>Detroit</b> Novi, MI Tel: 248-848-4000</p> <p><b>Houston, TX</b> Tel: 281-894-5983</p> <p><b>Indianapolis</b> Noblesville, IN Tel: 317-773-8323 Fax: 317-773-5453 Tel: 317-536-2380</p> <p><b>Los Angeles</b> Mission Viejo, CA Tel: 949-462-9523 Fax: 949-462-9608 Tel: 951-273-7800</p> <p><b>Raleigh, NC</b> Tel: 919-844-7510</p> <p><b>New York, NY</b> Tel: 631-435-6000</p> <p><b>San Jose, CA</b> Tel: 408-735-9110 Tel: 408-436-4270</p> <p><b>Canada - Toronto</b> Tel: 905-695-1980 Fax: 905-695-2078</p>	<p><b>Australia - Sydney</b> Tel: 61-2-9868-6733</p> <p><b>China - Beijing</b> Tel: 86-10-8569-7000</p> <p><b>China - Chengdu</b> Tel: 86-28-8665-5511</p> <p><b>China - Chongqing</b> Tel: 86-23-8980-9588</p> <p><b>China - Dongguan</b> Tel: 86-769-8702-9880</p> <p><b>China - Guangzhou</b> Tel: 86-20-8755-8029</p> <p><b>China - Hangzhou</b> Tel: 86-571-8792-8115</p> <p><b>China - Hong Kong SAR</b> Tel: 852-2943-5100</p> <p><b>China - Nanjing</b> Tel: 86-25-8473-2460</p> <p><b>China - Qingdao</b> Tel: 86-532-8502-7355</p> <p><b>China - Shanghai</b> Tel: 86-21-3326-8000</p> <p><b>China - Shenyang</b> Tel: 86-24-2334-2829</p> <p><b>China - Shenzhen</b> Tel: 86-755-8864-2200</p> <p><b>China - Suzhou</b> Tel: 86-186-6233-1526</p> <p><b>China - Wuhan</b> Tel: 86-27-5980-5300</p> <p><b>China - Xian</b> Tel: 86-29-8833-7252</p> <p><b>China - Xiamen</b> Tel: 86-592-2388138</p> <p><b>China - Zhuhai</b> Tel: 86-756-3210040</p>	<p><b>India - Bangalore</b> Tel: 91-80-3090-4444</p> <p><b>India - New Delhi</b> Tel: 91-11-4160-8631</p> <p><b>India - Pune</b> Tel: 91-20-4121-0141</p> <p><b>Japan - Osaka</b> Tel: 81-6-6152-7160</p> <p><b>Japan - Tokyo</b> Tel: 81-3-6880-3770</p> <p><b>Korea - Daegu</b> Tel: 82-53-744-4301</p> <p><b>Korea - Seoul</b> Tel: 82-2-554-7200</p> <p><b>Malaysia - Kuala Lumpur</b> Tel: 60-3-7651-7906</p> <p><b>Malaysia - Penang</b> Tel: 60-4-227-8870</p> <p><b>Philippines - Manila</b> Tel: 63-2-634-9065</p> <p><b>Singapore</b> Tel: 65-6334-8870</p> <p><b>Taiwan - Hsin Chu</b> Tel: 886-3-577-8366</p> <p><b>Taiwan - Kaohsiung</b> Tel: 886-7-213-7830</p> <p><b>Taiwan - Taipei</b> Tel: 886-2-2508-8600</p> <p><b>Thailand - Bangkok</b> Tel: 66-2-694-1351</p> <p><b>Vietnam - Ho Chi Minh</b> Tel: 84-28-5448-2100</p>	<p><b>Austria - Wels</b> Tel: 43-7242-2244-39 Fax: 43-7242-2244-393</p> <p><b>Denmark - Copenhagen</b> Tel: 45-4450-2828 Fax: 45-4485-2829</p> <p><b>Finland - Espoo</b> Tel: 358-9-4520-820</p> <p><b>France - Paris</b> Tel: 33-1-69-53-63-20 Fax: 33-1-69-30-90-79</p> <p><b>Germany - Garching</b> Tel: 49-8931-9700</p> <p><b>Germany - Haan</b> Tel: 49-2129-3766400</p> <p><b>Germany - Heilbronn</b> Tel: 49-7131-67-3636</p> <p><b>Germany - Karlsruhe</b> Tel: 49-721-625370</p> <p><b>Germany - Munich</b> Tel: 49-89-627-144-0 Fax: 49-89-627-144-44</p> <p><b>Germany - Rosenheim</b> Tel: 49-8031-354-560</p> <p><b>Israel - Ra'anana</b> Tel: 972-9-744-7705</p> <p><b>Italy - Milan</b> Tel: 39-0331-742611 Fax: 39-0331-466781</p> <p><b>Italy - Padova</b> Tel: 39-049-7625286</p> <p><b>Netherlands - Drunen</b> Tel: 31-416-690399 Fax: 31-416-690340</p> <p><b>Norway - Trondheim</b> Tel: 47-7289-7561</p> <p><b>Poland - Warsaw</b> Tel: 48-22-3325737</p> <p><b>Romania - Bucharest</b> Tel: 40-21-407-87-50</p> <p><b>Spain - Madrid</b> Tel: 34-91-708-08-90 Fax: 34-91-708-08-91</p> <p><b>Sweden - Gothenberg</b> Tel: 46-31-704-60-40</p> <p><b>Sweden - Stockholm</b> Tel: 46-8-5090-4654</p> <p><b>UK - Wokingham</b> Tel: 44-118-921-5800 Fax: 44-118-921-5820</p>



# Mouser Electronics

Authorized Distributor

Click to View Pricing, Inventory, Delivery & Lifecycle Information:

## Microchip:

[PIC16F18456-I/SS](#) [PIC16F18456-I/SO](#) [PIC16LF18456-I/SS](#) [PIC16F18455-E/SS](#) [PIC16F18455-I/SP](#) [PIC16F18455-I/SS](#) [PIC16F18455T-I/SO](#) [PIC16F18455T-I/SS](#) [PIC16F18455-I/SO](#) [PIC16F18455-E/SO](#) [PIC16F18455-E/SP](#) [PIC16LF18455-I/SO](#) [PIC16LF18455-E/SO](#) [PIC16F18456-I/SP](#) [PIC16LF18455T-I/SO](#) [PIC16F18456-E/SP](#) [PIC16F18456T-I/SO](#) [PIC16F18456-E/SO](#) [PIC16F18456-E/SS](#) [PIC16LF18456T-I/SO](#) [PIC16LF18456-E/SO](#) [PIC16LF18456-I/SO](#) [PIC16F18456-E/STX](#) [PIC16LF18455-I/SP](#) [PIC16LF18456T-I/SS](#) [PIC16F18455-E/STX](#) [PIC16LF18455-E/STX](#) [PIC16F18456-I/STX](#) [PIC16LF18455-E/SS](#) [PIC16LF18456-E/SP](#) [PIC16F18456T-I/SS](#) [PIC16LF18455-I/STX](#) [PIC16LF18455T-I/STX](#) [PIC16LF18455T-I/SS](#) [PIC16F18455T-I/STX](#) [PIC16LF18455-I/SS](#) [PIC16F18456T-I/STX](#) [PIC16LF18456-E/SS](#) [PIC16F18455-I/STX](#) [PIC16LF18455-E/SP](#) [PIC16LF18456-I/STX](#) [PIC16LF18456-E/STX](#) [PIC16LF18456-I/SP](#) [PIC16LF18456T-I/STX](#)

Компания «Океан Электроники» предлагает заключение долгосрочных отношений при поставках импортных электронных компонентов на взаимовыгодных условиях!

Наши преимущества:

- Поставка оригинальных импортных электронных компонентов напрямую с производств Америки, Европы и Азии, а так же с крупнейших складов мира;
- Широкая линейка поставок активных и пассивных импортных электронных компонентов (более 30 млн. наименований);
- Поставка сложных, дефицитных, либо снятых с производства позиций;
- Оперативные сроки поставки под заказ (от 5 рабочих дней);
- Экспресс доставка в любую точку России;
- Помощь Конструкторского Отдела и консультации квалифицированных инженеров;
- Техническая поддержка проекта, помощь в подборе аналогов, поставка прототипов;
- Поставка электронных компонентов под контролем ВП;
- Система менеджмента качества сертифицирована по Международному стандарту ISO 9001;
- При необходимости вся продукция военного и аэрокосмического назначения проходит испытания и сертификацию в лаборатории (по согласованию с заказчиком);
- Поставка специализированных компонентов военного и аэрокосмического уровня качества (Xilinx, Altera, Analog Devices, Intersil, Interpoint, Microsemi, Actel, Aeroflex, Peregrine, VPT, Syfer, Eurofarad, Texas Instruments, MS Kennedy, Miteq, Cobham, E2V, MA-COM, Hittite, Mini-Circuits, General Dynamics и др.);

Компания «Океан Электроники» является официальным дистрибьютором и эксклюзивным представителем в России одного из крупнейших производителей разъемов военного и аэрокосмического назначения «JONHON», а так же официальным дистрибьютором и эксклюзивным представителем в России производителя высокотехнологичных и надежных решений для передачи СВЧ сигналов «FORSTAR».



## JONHON

«JONHON» (основан в 1970 г.)

Разъемы специального, военного и аэрокосмического назначения:

(Применяются в военной, авиационной, аэрокосмической, морской, железнодорожной, горно- и нефтедобывающей отраслях промышленности)

«FORSTAR» (основан в 1998 г.)

ВЧ соединители, коаксиальные кабели, кабельные сборки и микроволновые компоненты:

(Применяются в телекоммуникациях гражданского и специального назначения, в средствах связи, РЛС, а так же военной, авиационной и аэрокосмической отраслях промышленности).



Телефон: 8 (812) 309-75-97 (многоканальный)

Факс: 8 (812) 320-03-32

Электронная почта: [ocean@oceanchips.ru](mailto:ocean@oceanchips.ru)

Web: <http://oceanchips.ru/>

Адрес: 198099, г. Санкт-Петербург, ул. Калинина, д. 2, корп. 4, лит. А