





88X5113

Integrated 100G/40G/Quad 25 Gbps
Ethernet PHY with Copper Cable and
Backplane Drive Capability

Datasheet - Public

Doc. No. MV-S110852-U0, Rev. B
July 30, 2018

Document Conventions

	Note: Provides related information or information of special importance.
	Caution: Indicates potential damage to hardware or software, or loss of data.
	Warning: Indicates a risk of personal injury.

For more information, visit our website at: www.marvell.com

Disclaimer

THIS DOCUMENT AND THE INFORMATION FURNISHED IN THIS DOCUMENT ARE PROVIDED "AS IS" WITHOUT ANY WARRANTY. MARVELL EXPRESSLY DISCLAIMS AND MAKES NO WARRANTIES OR GUARANTEES, WHETHER EXPRESS, ORAL, IMPLIED, STATUTORY, ARISING BY OPERATION OF LAW, OR AS A RESULT OF USAGE OF TRADE, COURSE OF DEALING, OR COURSE OF PERFORMANCE, INCLUDING THE IMPLIED WARRANTIES OF MERCHANTABILITY AND FITNESS FOR PARTICULAR PURPOSE AND NON-INFRINGEMENT.

This document, including any software or firmware included or referenced in this document is owned by Marvell. The information furnished in this document is provided for reference purposes only for use with Marvell products. It is the user's own responsibility to design or build products with the information. Marvell products are not authorized for use as critical components in medical devices, military systems, life or critical support devices, or related systems. Marvell is not liable, in whole or in part, and the user shall indemnify and hold Marvell harmless for any claim, damage, or other liability related to any such use of Marvell products. Marvell and the Marvell logo are registered trademarks of Marvell. For a more complete listing of Marvell trademarks, visit www.marvell.com.

Copyright © 2018. Marvell International Ltd. All rights reserved.



Marvell. Moving Forward Faster

PRODUCT OVERVIEW

The Marvell® 88X5113 device is a fully integrated single chip Ethernet transceiver that supports 25 GbE full-duplex transmission, over a variety of media including optics, passive copper cables and backplanes.

The device operates as a single port 100 Gbps Ethernet PHY/Quad port 25 Gbps Ethernet PHY. In this mode, the 88X5113 100 GbE and 25 GbE transmission over a variety of media including optics, passive copper cables and backplanes.

The 88X5113 has long reach SERDES, and includes Auto-Negotiation and coefficient training functionality.

In the 100 Gbps and 25 Gbps Ethernet PHY modes, the 88X5113 connects to the MAC/Switch device over a CAUI-4 or 25GAUI interface respectively. On the host interface, the device also supports the IEEE 802.3 Clause 91 100G Reed Solomon Forward Error Correction (RS-FEC) as well as the IEEE 802.3 Clause 108 RS-FEC and IEEE 802.3 Clause 74 KR-FEC for 25 GbE operation. These along with the support for Auto-Negotiation and training protocol enable the device to interface with the MAC over a 100G-KR4/25G-KR backplane link.

The PHY mode, the line interface of the 88X5113, is fully compliant to the IEEE 802.3bj and IEEE 802.3bm standards for 100 GbE and IEEE 802.3by specifications for 25 GbE operation over passive copper cables, optics and backplanes. The device supports the IEEE 802.3 Clause 91 and IEEE 802.3 Clause 108 Reed Solomon Forward Error Correction (RS-FEC) features, IEEE 802.3 Clause 74 KR-FEC, and Auto-Negotiation and coefficient training protocol required by the IEEE 802.3bj and IEEE 802.3by standards.

Internal registers can be accessed via an MDIO/MDC serial management interface which is compliant with IEEE 802.3 specification Clause 45. An MDC frequency of up to 25 MHz supported.

The 88X5113 is manufactured in a 14 mm x 14 mm 169-pin FCBGA package.

Features

- Single port 100 GbE/Quad 25 GbE PHY functionality
- Line equalization capability that meets IEEE 802.3bj and 802.3by specifications
- 100G/40GBASE-KR4/25G-KR compliant Host interface that exceed XLAUI/25GAUI requirements
- Fully autonomous adaptive equalization on line and host receivers
- 3 tap transmit FIR with programmable level and pre-emphasis
- Fully symmetric architecture with 100 GbE and 25 GbE RS-FEC and 10GE/25GE KR-FEC on both line and host interfaces
- Auto-Negotiation for backplanes and cable assemblies as defined by IEEE 802.3 Clause 73 of IEEE 802.3
- Support for transmit coefficient training protocol
- Clause 45 MDIO register access
- Ability to initialize the device from an external EEPROM
- Hardware interrupt pin for hardware interrupt generation capability
- LED pins with fully programmable event mapping and solid/blink modes
- Packet and PRBS pattern generation/checking capability
- Loopback mode for diagnostics
- Non-destructive eye monitors on all high speed interfaces
- IEEE-1149.1 and 1149.6 JTAG support
- Operating temperature range up to 105°C Junction
- 14 mm x 14 mm 169-pin FCBGA package with 1mm ball pitch

Applications

- 25 Gbps Ethernet NICs
- 100 Gbps/25 Gbps Ethernet line cards
- 100 Gbps/25 Gbps Ethernet backplanes

Figure 1: 88X5113 in a 25 GbE/100 GE Line Card Application

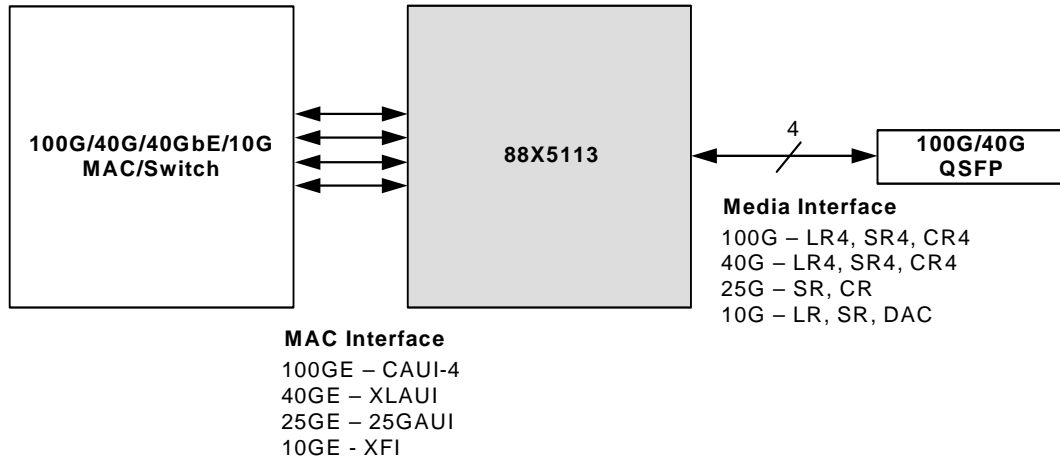

Figure 2: 88X5113 in a 25 GbE/100 GE Blade Switch/Server Application

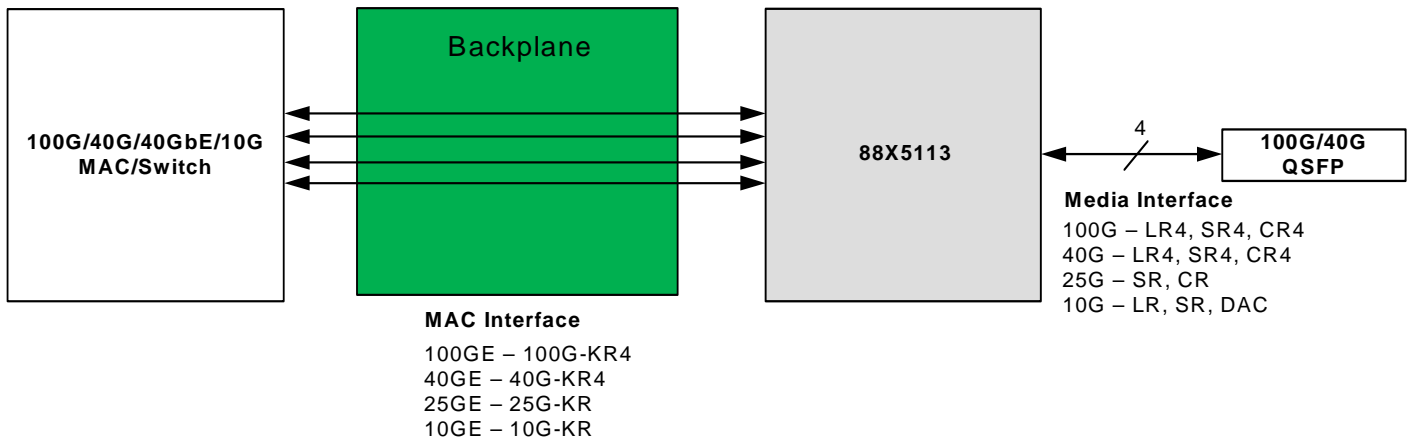

Table of Contents

Product Overview	3
1 General Device Description	13
2 Signal Description	15
2.1 Pin Map	16
2.2 Pin Description	17
2.3 88X5113 Device Pin Assignment List	23
3 Functional Description	26
3.1 Data Path	26
3.1.1 PCS Mode	27
3.2 Reset	28
3.3 Hardware Configuration	30
3.4 Register Access	31
3.4.1 IEEE MDC/MDIO Register Access	31
3.4.2 TWSI Register Access	32
3.4.2.1 Bus Operation	32
3.4.2.2 Clause 45 Encapsulation	33
3.5 TWSI, GPIO, and LED	36
3.5.1 GPIO[3:0] and LED[3:0]	36
3.5.1.1 Controlling and Sensing	36
3.5.1.2 GPIO Interrupts	36
3.5.1.3 LED	38
3.5.2 TWSI, GPIO 4, and GPIO 5	42
3.5.3 Two-wire Serial Interface (TWSI)	46
3.6 Interrupt	46
3.7 Power Management	53
3.8 IEEE 1149.1 and 1149.6 Controller	54
3.8.1 BYPASS Instruction	54
3.8.2 SAMPLE/PRELOAD Instruction	55
3.8.3 EXTEST Instruction	57
3.8.4 CLAMP Instruction	57
3.8.5 HIGH-Z Instruction	58
3.8.6 ID CODE Instruction	58
3.8.7 EXTEST_PULSE Instruction	58
3.8.8 EXTEST_TRAIN Instruction	58
3.9 Temperature Sensor	59
3.10 On-chip Processor	59
3.11 Synchronous Ethernet Mode	59
3.12 Power Supplies	63

4	Line Side Description	64
4.1	Interface Modes of Operation	65
4.2	Electrical Interface	72
4.3	PCS and PMA	72
4.3.1	100GBASE-R4 PCS (Modes P100*)	73
4.3.2	40GBASE-R4, 50GBASE-R4, 50GBASE-R2 PCS (Modes P40*, P50*)	75
4.3.3	5GBASE-R, 10GBASE-R, and 25GBASE-R PCS (Modes P5L, P10*, P25*)	77
4.3.4	SGMII, 1000BASE-X, and 2.5GBASE-X	78
4.3.4.1	PCS	78
4.3.4.2	1000BASE-X Auto-Negotiation	78
4.3.4.3	SGMII Auto-Negotiation	79
4.3.4.4	Auto-Negotiation Bypass Mode	79
4.4	Auto-Negotiation	80
4.5	Loopback	81
4.5.1	Line-side Loopbacks	81
4.5.2	Host-side Loopbacks	82
4.6	Synchronized FIFO	84
4.7	Traffic Generation and Checking	84
4.7.1	Packet Generator	86
4.7.2	Packet Checker	90
4.8	PRBS Generation and Checking	91
4.8.1	General PRBS Generators and Checkers	91
4.8.2	40GBASE-R4-specific Generators and Checkers	93
4.8.3	100GBASE-R4-specific Generators and Checkers	93
4.9	Eye Monitor	93
5	Host Side Description	94
6	Chip Bring Up	99
6.1	Power Sequencing	99
6.2	Reset and Configuration	99
7	Electrical Specifications	100
7.1	Absolute Maximum Ratings	100
7.2	Recommended Operating Conditions	101
7.3	Package Thermal Information	102
7.3.1	Thermal Conditions for 169-pin, FCBGA Package	102
7.4	Current Consumption	103
7.4.1	88X5113 Current Consumption (Commercial)	103
7.4.2	88X5113 Current Consumption (Industrial)	105
7.5	Digital I/O Electrical Specifications	107
7.5.1	DC Operating Conditions	107
7.5.2	AC Operating Conditions	108
7.5.3	Reset Timing	108
7.5.4	MDC/MDIO Management Interface Timing	109
7.5.5	JTAG Timing	110
7.6	SERDES Electrical Specifications	111
7.6.1	Chip-to-Module 100 Gbps/25 Gbps Electrical Characteristics	111
7.6.1.1	Chip-to-Module 100 Gbps/25 Gbps Transmitter and Receiver Characteristics	111

7.6.1.2	Chip-to-Module CAUI-4/XXVAUI-1 Interface Transmitter Output Voltage Limits and Definitions	113
7.6.2	Chip-to-Chip 100 Gbps/25 Gbps (CAUI-4/XXVAUI-1) Electrical Characteristics	115
7.6.2.1	Chip-to-Chip 100 Gbps/25 Gbps (CAUI-4/XXVAUI-1) Transmitter and Receiver Characteristics	115
7.6.2.2	Chip-to-Chip CAUI-4/XXVAUI-1 Interface Transmitter Output Voltage Limits and Definitions	117
7.6.3	100GBASE-CR4/50GBASE-CR2/25GBASE-CR Electrical Characteristics	119
7.6.3.1	100GBASE-CR4/50GBASE-CR2/25GBASE-CR Interface Transmitter and Receiver Characteristics	119
7.6.3.2	100GBASE-CR4/50GBASE-CR2/25GBASE-CR Interface Transmitter Output Voltage Limits and Definitions	122
7.6.4	100GBASE-KR4/50GBASE-KR2/25GBASE-KR Electrical Characteristics	123
7.6.4.1	100GBASE-KR4/50GBASE-KR2/25GBASE-KR Interface Transmitter and Receiver Characteristics	123
7.6.4.2	100GBASE-KR4/50GBASE-KR2/25GBASE-KR Interface Transmitter Output Voltage Limits and Definitions	126
7.6.5	40 Gbps Parallel Physical Interface (XLPPI) Electrical Characteristics	127
7.6.5.1	40 Gbps Parallel Physical Interface (XLPPI) Interface Transmitter and Receiver Characteristics	127
7.6.5.2	XLPPI Interface Transmitter Output Voltage Limits and Definitions	129
7.6.6	40 Gbps Attachment Unit Interface (XLAUI) Electrical Characteristics	131
7.6.6.1	40 Gbps Attachment Unit Interface (XLAUI) Interface Transmitter and Receiver Characteristics	131
7.6.6.2	XLAUI Interface Transmitter Output Voltage Limits and Definitions	134
7.6.7	40GBASE-CR4 Electrical Characteristics	135
7.6.7.1	40GBASE-CR4 Interface Transmitter and Receiver Characteristics	135
7.6.7.2	40GBASE-CR4 Interface Transmitter Output Voltage Limits and Definitions	137
7.6.8	40GBASE-KR4 Electrical Characteristics	138
7.6.8.1	40GBASE-KR4 Interface Transmitter and Receiver Characteristics	138
7.6.8.2	40GBASE-KR4 Interface Transmitter Output Voltage Limits and Definitions	140
7.6.9	SFP+ Interface (SFI) Limiting Module Electrical Characteristics	142
7.6.9.1	SFI Transmitter and Receiver Characteristics	142
7.6.9.2	SFP+ Direct Attach Cable (10GSFP+CU Appendix E) Transmitter and Receiver Characteristics	144
7.6.10	10 Gigabit Small Form Factor Pluggable Interface (XFI) Electrical Characteristics	148
7.6.10.1	XFI Interface Transmitter and Receiver Characteristics	148
7.6.11	10GBASE-KR Electrical Characteristics	150
7.6.11.1	10GBASE-KR Interface Transmitter and Receiver Characteristics	150
7.6.11.2	10GBASE-KR Interface Transmitter Output Voltage Limits and Definitions	152
7.7	Reference Clock	153
7.8	Output 25 MHz Clock	154
7.9	Latency	155
8	Mechanical Drawings	156
8.1	Package Mechanical Drawings	156
9	Order Information	159
9.1	Ordering Part Numbers and Package Markings	159
9.1.1	Marking Example	160
A	Revision History	161

List of Figures

Product Overview	3
Figure 1: 88X5113 in a 25 GbE/100 GE Line Card Application	4
Figure 2: 88X5113 in a 25 GbE/100 GE Blade Switch/Server Application	4
1 General Device Description	13
Figure 3: 88X5113 Device Functional Block Diagram	14
2 Signal Description	15
3 Functional Description	26
Figure 4: 88X5113 Main Operational Modes	26
Figure 5: Typical MDC/MDIO Read Operation	31
Figure 6: Typical MDC/MDIO Write Operation	31
Figure 7: First Two Bytes of All Transactions	33
Figure 8: Write, Full Header, Retain REGAD	34
Figure 9: Write, Full Header, Post-Increment	34
Figure 10: Write, Abbreviated Header, Retain REGAD	35
Figure 11: Write, Abbreviated Header, Post-Increment	35
Figure 12: Read, Full Header, Retain REGAD	35
Figure 13: Read, Full Header, Post-Increment	35
Figure 14: Read, Abbreviated Header, Retain REGAD	35
Figure 15: Read, Abbreviated Header, Post-Increment	35
Figure 16: Dummy Write Command to Set REGAD	35
Figure 17: LED Chain	38
Figure 18: Various LED Hookup Configurations	39
Figure 19: Interrupt Hierarchy and Aggregation from Different Blocks	47
Figure 20: Synchronous Ethernet with 88X5113 in a Non-Ethernet Application such as CPRI	60
Figure 21: Synchronous Ethernet with 88X5113 in an Ethernet Application	61
Figure 22: Multiplexing Scheme for Recovered Clock RCLKA	62
4 Line Side Description	64
Figure 23: 100GBASE-R4 Data Path	74
Figure 24: 40GBASE-R4, 50GBASE-R4, and 50GBASE-R2 Datapath	76
Figure 25: 5GBASE-R, 10GBASE-R, and 25GBASE-R Datapath	78
Figure 26: Line-side Loopback	81
Figure 27: Turn On Deep Host Loopback	82
Figure 28: Packet Format	86
Figure 29: Normal CRC Calculation (in XLGMII/40G and CGMII/100G Format)	87
Figure 30: Extended CRC Calculation (in XLGMII/40G and CGMII/100G Format)	87
Figure 31: Packet without CRC (in XLGMII/40G and CGMII/100G Format)	88

5	Host Side Description	94
6	Chip Bring Up.....	99
7	Electrical Specifications	100
	Figure 32: Reset Timing.....	108
	Figure 33: MDC/MDIO Management Interface	109
	Figure 34: JTAG Timing.....	110
	Figure 35: Chip-to-Module CAUI-4/XXVAUI-1 Interface Transmitter Output Voltage Limits and Definitions... 113	
	Figure 36: Chip-to-Module CAUI-4/XXVAUI-1 Transmitter Output Differential Amplitude and Eye Opening .. 114	
	Figure 37: Chip-to-Chip CAUI-4/XXVAUI-1 Interface Transmitter Output Voltage Limits and Definitions	117
	Figure 38: Chip-to-Chip CAUI-4/XXVAUI-1 Transmitter Output Differential Amplitude and Eye Opening.....	118
	Figure 39: 10GBASE-CR4/50GBASE-CR2/25GBASE-CR Interface Transmitter Output Voltage Limits and Definitions	122
	Figure 40: 10GBASE-KR4/50GBASE-KR2/25GBASE-KR Interface Transmitter Output Voltage Limits and Definitions	126
	Figure 41: XLPPI Interface Transmitter Output Voltage Limits and Definitions	129
	Figure 42: XLPPI Transmitter Output Differential Amplitude and Eye Opening.....	130
	Figure 43: XLAUI Interface Transmitter Output Voltage Limits and Definitions	134
	Figure 44: XLAUI Transmitter Output Differential Amplitude and Eye Opening.....	134
	Figure 45: 40GBASE-CR4Interface Transmitter Output Voltage Limits and Definitions.....	137
	Figure 46: 40GBASE-CR4Transmitter Output Differential Amplitude and Eye Opening	137
	Figure 47: 40GBASE-KR4 Interface Transmitter Output Voltage Limits and Definitions	140
	Figure 48: 40GBASE-KR4 Transmitter Output Differential Amplitude and Eye Opening	141
	Figure 49: SFI Transmitter Output Voltage Limits and Definitions	146
	Figure 50: SFI Transmitter Output Differential Amplitude and Eye Opening	147
	Figure 51: 10GBASE-KR Interface Transmitter Output Voltage Limits and Definitions	152
	Figure 52: 10GBASE-KR Transmitter Output Differential Amplitude and Eye Opening	152
	Figure 53: Reference Clock Input Waveform	153
8	Mechanical Drawings	156
	Figure 54: 169-pin FCBGA 14 × 14 Package Mechanical Drawings — Top and Side View	156
	Figure 55: 169-pin FCBGA 14 × 14 Package Mechanical Drawings — Bottom View	157
9	Order Information	159
	Figure 56: Sample Part Number	159
	Figure 57: 88X5113 169-pin FCBGA Commercial Green Package Marking and Pin 1 Location	160
	Figure 58: 88X5113 169-pin FCBGA Industrial Green Package Marking and Pin 1 Location.....	160
A	Revision History	161

List of Tables

Product Overview	3
1 General Device Description	13
2 Signal Description	15
Table 1: Pin Type Definitions	15
Table 2: Line Side Interface	17
Table 3: Host Side Interface	17
Table 4: Clocking and Reference	18
Table 5: Configuration and Reset	18
Table 6: Management Interface	18
Table 7: EEPROM/GPIO	18
Table 8: JTAG	19
Table 9: GPIO/LED	19
Table 10: TEST	19
Table 11: Power and Ground	20
Table 12: 88X5113 Pin List — Alphabetical by Signal Name	23
3 Functional Description	26
Table 13: Valid PCS Mode Interface Connections	27
Table 14: Reset Bits	28
Table 15: Hardware Configuration	30
Table 16: Extensions for Management Frame Format for Indirect Access	31
Table 17: INS[2:0] Definition	33
Table 18: GPIO, LED Signal Mapping	36
Table 19: GPIO/LED Controls	37
Table 20: LED[3:0] Control and Status Register Bits	39
Table 21: LED Timer Control	40
Table 22: TWSI and GPIO Signal Mapping	42
Table 23: SCL Control	42
Table 24: SDA Control	43
Table 25: I/O Open Drain Control	45
Table 26: Global Interrupt Control	46
Table 27: Global Interrupt Status	47
Table 28: 1G/2.5G Interrupt Enable, Interrupt Status, and Real-Time Status	48
Table 29: 10G/25G Interrupt Enable, Interrupt Status, and Real-Time Status	48
Table 30: 40G/50G Interrupt Enable, Interrupt Status, and Real-Time Status	49
Table 31: 100G Interrupt Enable, Interrupt Status, and Real-Time Status	49
Table 32: Excessive Link Error Interrupt Enable, Interrupt Status, and Real-Time Status	50
Table 33: GPIO1, GPIO2, GPIO3, GPIO4, CLK_OUT_SE1, CLK_OUT_SE2 Pins Interrupt	51

Table 34:	Temp Sensor and GPIOs, Interrupt Enable, Interrupt Status	51
Table 35:	Power Down Control Bits	53
Table 36:	TAP Controller Opcodes	54
Table 37:	Boundary Scan Chain Order	55
Table 38:	ID CODE Instruction	58
4	Line Side Description	64
Table 39:	Mode Definition Reference	65
Table 40:	Interface Modes of Operation	66
Table 41:	Register Control to Select Mode of Operation	69
Table 42:	Base Link Register on PCS Modes	71
Table 43:	PCS Types	72
Table 44:	SGMII Auto-Negotiation Modes	79
Table 45:	Shallow Line Loopback Control Bits	81
Table 46:	Deep Loopback Control Bits	82
Table 47:	Shallow Line Loopback Control Bits	83
Table 48:	Deep Loopback Control Bits	83
Table 49:	Packet Generator and Checker Register Mapping Data	84
Table 50:	Packet Generator and Checker Control and Counters	85
Table 51:	Registers Controlling Packet Generation	87
Table 52:	IPG Configuration	88
Table 53:	Packet Data Generation	89
Table 54:	Registers Controlling Packet Checker	90
Table 55:	PRBS Register Address Offsets	91
Table 56:	Supported Line-side PRBS Patterns	92
Table 57:	IEEE PCS and PMA PRBS Control Register	93
5	Host Side Description	94
Table 58:	Equivalent Registers Between Line and Host Interface	94
Table 59:	Non-Reversible Mode Combinations	98
6	Chip Bring Up	99
7	Electrical Specifications	100
Table 60:	Absolute Maximum Ratings	100
Table 61:	Recommended Operating Conditions (Commercial)	101
Table 62:	Thermal Conditions for 169-pin, FCBGA Package	102
Table 63:	DVDD Current Consumption	103
Table 64:	AVDDL and AVDDH Current Consumption	104
Table 65:	AVDDC and AVDDT Current Consumption	104
Table 66:	DVDD Current Consumption	105
Table 67:	AVDDL and AVDDH Current Consumption	106
Table 68:	AVDDC and AVDDT Current Consumption	107
Table 69:	DC Operating Conditions	107
Table 70:	AC Operating Conditions	108

Table 71:	Reset Timing	108
Table 72:	MDC/MDIO Management Interface Timing	109
Table 73:	JTAG Timing	110
Table 74:	Chip-to-Module CAUI-4/XXVAUI-1 Transmitter and Receiver Characteristics	111
Table 75:	Chip-to-Module CAUI-4/XXVAUI-1 Settings and Configuration	112
Table 76:	Chip-to-Chip Gbps CAUI-4/XXVAUI-1 Interface Transmitter and Receiver Characteristics	115
Table 77:	Chip-to-Chip CAUI-4/XXVAUI-1 Settings and Configuration	116
Table 78:	10GBASE-CR4/50GBASE-CR2/25GBASE-CR Interface Transmitter and Receiver Characteristics	119
Table 79:	10GBASE-CR4/50GBASE-CR2/25GBASE-CR Settings and Configuration	121
Table 80:	10GBASE-KR4/50GBASE-KR2/25GBASE-KR Interface Transmitter and Receiver Characteristics	123
Table 81:	10GBASE-KR4/50GBASE-KR2/25GBASE-KR Settings and Configuration	125
Table 82:	XLPI Interface Transmitter and Receiver Characteristics	127
Table 83:	XLPI Settings and Configuration	129
Table 84:	XLAUI Interface Transmitter and Receiver Characteristics	131
Table 85:	XLAUI Settings and Configuration	133
Table 86:	40GBASE-CR4 Interface Transmitter and Receiver Characteristics	135
Table 87:	40GBASE-CR4 Settings and Configuration	136
Table 88:	40GBASE-KR4 Interface Transmitter and Receiver Characteristics	138
Table 89:	40GBASE-KR4 Settings and Configuration	139
Table 90:	SFI Transmitter and Receiver Characteristics	142
Table 91:	SFI Settings and Configuration	143
Table 92:	10GSFP+CU Transmitter and Receiver Characteristics	144
Table 93:	10GSFP+CU Settings and Configuration	146
Table 94:	XFI Interface Transmitter and Receiver Characteristics	148
Table 95:	10GBASE-KR Interface Transmitter and Receiver Characteristics	150
Table 96:	10GBASE-KR Settings and Configuration	151
Table 97:	Reference Clock	153
Table 98:	Output 25 MHz Clock	154
Table 99:	Chip Pin-to-pin Latency (Rx + Tx)	155
8	Mechanical Drawings	156
Table 100:	169-pin FCBGA (14 mm × 14 mm) Package Dimensions	158
9	Order Information	159
Table 101:	88X5113 Part Order Option	159
A	Revision History	161
Table 102:	Revision History	161

1

General Device Description

The 88X5113 device is an Ethernet SERDES Transceiver that supports one port of 100GBASE-R4, consortium 50GBASE-R2, overclocked 40GBASE-R2, 40GBASE-R4, and four ports of 25GBASE-R, consortium 25GBASE-R, 10GBASE-R, 5GBASE-R, 2.5GBASE-X, 1000BASE-X, and SGMII on both the line and host interfaces. Auto-Negotiation, equalization and KR training are available to support backplane, twin-ax, and optical options in the various modes. Reed Solomon FEC and KR-FEC can be enabled as well. The various CAUI-4, XLPPI, XLAUI, SFI, XFI interfaces are supported.

The device can be used in PCS mode application where data is passed from one PCS to another PCS.

Device registers can be accessed through standard Clause 45 MDC/MDIO. The device operates from a 0.9V/0.95V (I-temp operation) digital core voltage and a 1.0V analog voltage. The digital I/O signals can operate at 3.3V, 2.5V, 1.8V, 1.5V, 1.2V, and 1.05V. The device utilizes a 14 mm x 14 mm 169-ball FCBGA package, and supports an operating junction temperature of up to 105°C.

Figure 3: 88X5113 Device Functional Block Diagram

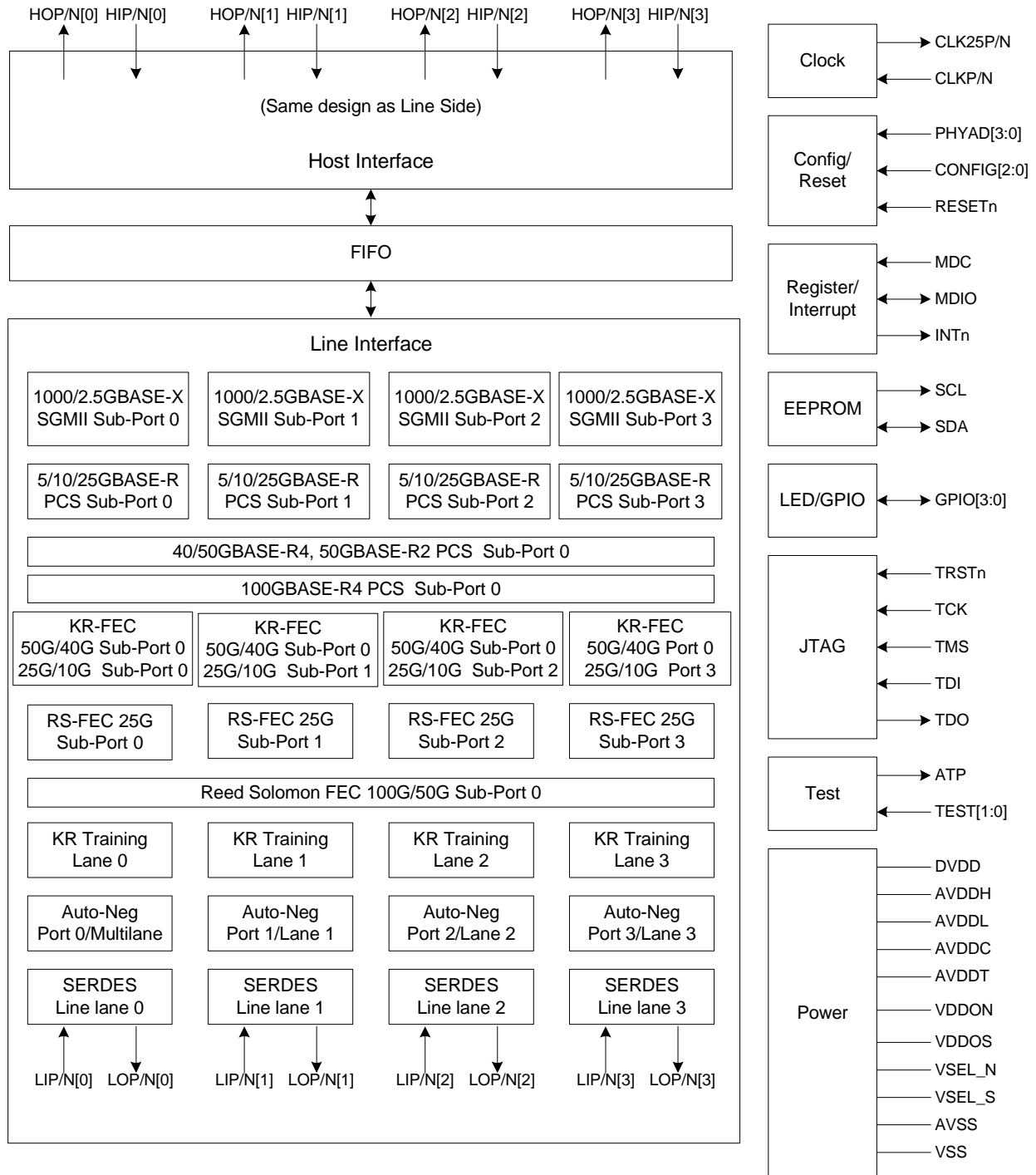

2

Signal Description

Table 1: Pin Type Definitions

Pin Type	Definition
H	Input with hysteresis
I/O	Input and output
I	Input only
O	Output only
PU	Internal pull-up
PD	Internal pull-down
OD	Open drain output
Z	Tri-state output
mA	DC sink capability
AI	Analog input
AO	Analog output
DI	Digital input
DO	Digital output

2.1 Pin Map

	1	2	3	4	5	6	7	8	9	10	11	12	13	
A	AVSS	AVDDH	AVSS	AVDDH	RESETn	GPIO[3]	GPIO[2]	GPIO[1]	DVDD	AVDDL	AVSS	AVDDL	AVSS	A
B	HIN[3]	AVSS	HOP[3]	AVSS	TRSTn	TDO	GPIO[0]	SCL	SDA	AVSS	LOP[3]	AVSS	LIN[3]	B
C	HIP[3]	AVSS	HON[3]	AVSS	TMS	VSEL_N	VDDON	TCK	TDI	AVSS	LON[3]	AVSS	LIP[3]	C
D	AVSS	AVSS	AVSS	AVDDH	VSS	DVDD	VSS	DVDD	VSS	AVDDL	AVSS	AVSS	AVSS	D
E	HIN[2]	AVSS	HOP[2]	AVSS	DVDD	VSS	DVDD	VSS	DVDD	AVSS	LOP[2]	AVSS	LIN[2]	E
F	HIP[2]	AVSS	HON[2]	AVSS	VSS	DVDD	VSS	DVDD	VSS	AVSS	LON[2]	AVSS	LIP[2]	F
G	AVSS	AVDDH	AVSS	AVDDH	DVDD	VSS	DVDD	VSS	DVDD	AVDDL	AVSS	AVDDL	AVSS	G
H	HIN[1]	AVSS	HOP[1]	AVSS	VSS	DVDD	VSS	DVDD	VSS	AVSS	LOP[1]	AVSS	LIN[1]	H
J	HIP[1]	AVSS	HON[1]	AVSS	TEST[1]	CONFIG[2]	VDDOS	CONFIG[1]	CONFIG[0]	AVSS	LON[1]	AVSS	LIP[1]	J
K	AVSS	AVSS	AVSS	AVDDH	PHYAD[0]	VSEL_S	VSS	PHYAD[1]	PHYAD[3]	AVDDL	AVSS	AVSS	AVSS	K
L	HIN[0]	AVSS	HOP[0]	AVSS	TEST[0]	INTn	MDIO	MDC	PHYAD[2]	AVSS	LOP[0]	AVSS	LIN[0]	L
M	HIP[0]	AVSS	HON[0]	AVSS	AVSS	ATP	AVDDT	AVDDC	AVSS	AVSS	LON[0]	AVSS	LIP[0]	M
N	AVSS	AVDDH	AVSS	AVDDH	CLKP	CLKN	AVSS	CLK25P	CLK25N	AVDDL	AVSS	AVDDL	AVSS	N
	1	2	3	4	5	6	7	8	9	10	11	12	13	

(Top View)

2.2 Pin Description

Table 2: Line Side Interface

Pin #	Pin Name	Pin Type	Description
C13 F13 J13 M13	LIP[3] LIP[2] LIP[1] LIP[0]	AI	Line Input Positive
B13 E13 H13 L13	LIN[3] LIN[2] LIN[1] LIN[0]	AI	Line Input Negative
B11 E11 H11 L11	LOP[3] LOP[2] LOP[1] LOP[0]	AO	Line Output Positive
C11 F11 J11 M11	LON[3] LON[2] LON[1] LON[0]	AO	Line Output Negative

Table 3: Host Side Interface

Pin #	Pin Name	Pin Type	Description
C1 F1 J1 M1	HIP[3] HIP[2] HIP[1] HIP[0]	AI	Host Input Positive
B1 E1 H1 L1	HIN[3] HIN[2] HIN[1] HIN[0]	AI	Host Input Negative
B3 E3 H3 L3	HOP[3] HOP[2] HOP[1] HOP[0]	AO	Host Output Positive
C3 F3 J3 M3	HON[3] HON[2] HON[1] HON[0]	AO	Host Output Negative



Note

The SERDES receiver is AC coupled on-chip. There is no off-chip AC-coupling capacitor required as long as the Rx input common mode is between AGND and AVDD (1.0V) and Rx amplitude is less than 1200 mVpp differential.

Table 4: Clocking and Reference

Pin #	Pin Name	Pin Type	Description
N5	CLKP	AI	Reference Clock Positive. Refer to Section 7.7 for further details.
N6	CLKN	AI	Reference Clock Negative. Refer to Section 7.7 for further details.
N8	CLK25P	AO	25 MHz Clock Output Positive. Refer to Section 7.8 for further details.
N9	CLK25N	AO	25 MHz Clock Output Negative. Refer to Section 7.8 for further details.

Table 5: Configuration and Reset

Pin #	Pin Name	Pin Type	Description
K9 L9 K8 K5	PHYAD[3] PHYAD[2] PHYAD[1] PHYAD[0]	DI/ PD	Address In MDIO mode, this sets the PHYAD[3:0] setting. PHYAD[4] is set to 0. In TWSI mode, this sets the A[3:0] setting. A[6:4] is set to 100.
J6 J8 J9	CONFIG[2] CONFIG[1] CONFIG[0]	DI/PD	CONFIG[0] - 0 = MDIO 1 = TWSI CONFIG[1] - 0 = Do not load EEPROM 1 = Load EEPROM CONFIG[2] - Reserved
A5	RESETn	DI	Hardware Reset, 0 = Reset 1 = Normal operation

Table 6: Management Interface

Pin #	Pin Name	Pin Type	Description
L8	MDC/SSCL	DI	Management Interface Clock, or SCL for TWSI slave mode See Section 3.4.1, IEEE MDC/MDIO Register Access for details.
L7	MDIO/SSDA	IO,OD	Management Interface Data, or SDA for TWSI slave mode See Section 3.4.1, IEEE MDC/MDIO Register Access for details. This pin can be open drain.
L6	INTn	OD	Interrupt.

Table 7: EEPROM/GPIO

Pin #	Pin Name	Pin Type	Description
B8	SCL	IO, OD	Multi-function pin for EEPROM Clock, or GPIO[4]. Primary function is Two Wire Serial Interface Clock, EEPROM Clock.
B9	SDA	IO, OD	Multi-function pin for EEPROM Data, or GPIO[5]. Primary function is Two Wire Serial Interface Data, EEPROM Data.

Table 8: JTAG

Pin #	Pin Name	Pin Type	Description
C9	TDI	DI/PU	JTAG Test In
B6	TDO	DO, OD	JTAG Test Out
C5	TMS	DI/PU	JTAG Test Control
C8	TCK	DI/PU	JTAG Test Clock
B5	TRSTn	DI/PU	JTAG Test Reset For normal operation, TRSTn should be pulled low with a 4.7 kohm pull-down resistor.

Table 9: GPIO/LED

Pin #	Pin Name	Pin Type	Description
A6 A7 A8 B7	GPIO[3] GPIO[2] GPIO[1] GPIO[0]	I/O	GPIO

Table 10: TEST

Pin #	Pin Name	Pin Type	Description
J5 L5	TEST[1] TEST[0]	DI	Test pins. Tie to VSS in normal operation.
M6	ATP	AO	Analog DC test point.

Table 11: Power and Ground

Pin #	Pin Name	Pin Type	Description
A9 D6 D8 E5 E7 E9 F6 F8 G5 G7 G9 H6 H8	DVDD	Digital Power	0.9V/0.95V (I-temp) Digital Core Power
A10 A12 D10 G10 G12 K10 N10 N12	AVDDL	Analog Power	1.0V Analog Core Power - Line SERDES Side
A2 A4 D4 G2 G4 K4 N2 N4	AVDDH	Analog Power	1.0V Analog Core Power - Host SERDES Side
M8	AVDDC	Analog Power	1.0V Common Analog Power.
M7	AVDDT	Analog Power	2.5V, or 3.3V Temperature Sensor and 25 MHz PLL power. AVDDT must be AC coupled to VSS when not used.
C7	VDDON	I/O Power	1.05V, 1.2V, 1.5V, 1.8V, 2.5V, or 3.3V I/O Power (North side). See Section 3.12 for more details.
J7	VDDOS	I/O Power	1.05V, 1.2V, 1.5V, 1.8V, 2.5V, or 3.3V I/O Power (South side). See Section 3.12 for more details.
C6	VSEL_N	VDDON Level Select	Tie to VSS for 2.5V or 3.3V operation, otherwise tie to VDDON for 1.05V, 1.2V, 1.5V, 1.8V operation
K6	VSEL_S	VDDOS Level Select	Tie to VSS for 2.5V or 3.3V operation, otherwise tie to VDDOS for 1.05V, 1.2V, 1.5V, 1.8V operation

Table 11: Power and Ground (Continued)

Pin #	Pin Name	Pin Type	Description
A1	AVSS	Ground	Ground
A3			
A11			
A13			
B2			
B4			
B10			
B12			
C2			
C4			
C10			
C12			
D1			
D2			
D3			
D11			
D12			
D13			
E2			
E4			
E10			
E12			
F2			
F4			
F10			
F12			
G1			
G3			
G11			
G13			
H2			
H4			
H10			
H12			
J2			
J4			
J10			
J12			
K1			
K2			
K3			
K11			
K12			
K13			
L2			
L4			
L10			
L12			
M2			

Table 11: Power and Ground (Continued)

Pin #	Pin Name	Pin Type	Description
M4 M5 M9 M10 M12 N1 N3 N7 N11 N13	AVSS (cont.)	Ground	Ground
D5 D7 D9 E6 E8 F5 F7 F9 G6 G8 H5 H7 H9 K7	VSS	Ground	Ground

2.3 88X5113 Device Pin Assignment List

Table 12:88X5113 Pin List — Alphabetical by Signal Name

Pin Number	Pin Name
M6	ATP
M8	AVDDC
A2	AVDDH
A4	AVDDH
D4	AVDDH
G2	AVDDH
G4	AVDDH
N2	AVDDH
N4	AVDDH
K4	AVDDH
A10	AVDDL
A12	AVDDL
D10	AVDDL
G10	AVDDL
G12	AVDDL
K10	AVDDL
N10	AVDDL
N12	AVDDL
M7	AVDDT
A1	AVSS
A3	AVSS
A11	AVSS
A13	AVSS
B2	AVSS
B4	AVSS
B10	AVSS
B12	AVSS

Pin Number	Pin Name
C2	AVSS
C4	AVSS
C10	AVSS
C12	AVSS
D1	AVSS
D2	AVSS
D3	AVSS
D11	AVSS
D12	AVSS
D13	AVSS
E2	AVSS
E4	AVSS
E10	AVSS
E12	AVSS
F2	AVSS
F4	AVSS
F10	AVSS
F12	AVSS
G1	AVSS
G3	AVSS
G11	AVSS
G13	AVSS
H2	AVSS
H4	AVSS
H10	AVSS
H12	AVSS
J2	AVSS

Pin Number	Pin Name
J4	AVSS
J10	AVSS
J12	AVSS
K1	AVSS
K2	AVSS
K3	AVSS
K11	AVSS
K12	AVSS
K13	AVSS
L2	AVSS
L4	AVSS
L10	AVSS
L12	AVSS
M2	AVSS
M4	AVSS
M5	AVSS
M9	AVSS
M10	AVSS
M12	AVSS
N1	AVSS
N3	AVSS
N7	AVSS
N11	AVSS
N13	AVSS
N9	CLK25N
N8	CLK25P
N6	CLKN
N5	CLKP
J9	CONFIG[0]

Pin Number	Pin Name
J8	CONFIG[1]
J6	CONFIG[2]
A9	DVDD
D6	DVDD
D8	DVDD
E5	DVDD
E7	DVDD
E9	DVDD
F6	DVDD
F8	DVDD
G5	DVDD
G7	DVDD
G9	DVDD
H6	DVDD
H8	DVDD
B7	GPIO[0]
A8	GPIO[1]
A7	GPIO[2]
A6	GPIO[3]
L1	HIN[0]
H1	HIN[1]
E1	HIN[2]
B1	HIN[3]
M1	HIP[0]
J1	HIP[1]
F1	HIP[2]
C1	HIP[3]
M3	HON[0]
J3	HON[1]

Signal Description
88X5113 Device Pin Assignment List

Pin Number	Pin Name
F3	HON[2]
C3	HON[3]
L3	HOP[0]
H3	HOP[1]
E3	HOP[2]
B3	HOP[3]
L6	INTn
L13	LIN[0]
H13	LIN[1]
E13	LIN[2]
B13	LIN[3]
M13	LIP[0]
J13	LIP[1]
F13	LIP[2]
C13	LIP[3]
M11	LON[0]
J11	LON[1]
F11	LON[2]
C11	LON[3]
L11	LOP[0]
H11	LOP[1]
E11	LOP[2]
B11	LOP[3]
L8	MDC
L7	MDIO
K5	PHYAD[0]
K8	PHYAD[1]
L9	PHYAD[2]
K9	PHYAD[3]

Pin Number	Pin Name
A5	RESETn
B8	SCL
B9	SDA
C8	TCK
C9	TDI
B6	TDO
L5	TEST[0]
J5	TEST[1]
C5	TMS
B5	TRSTn
C7	VDDON
J7	VDDOS
C6	VSEL_N
K6	VSEL_S
D5	VSS
D7	VSS
D9	VSS
E6	VSS
E8	VSS
F5	VSS
F7	VSS
F9	VSS
G6	VSS
G8	VSS
H5	VSS
H7	VSS
H9	VSS
K7	VSS

3 Functional Description

This section describes the chip-level functionality. Sections 4 and 5 describe the individual units in detail.

3.1 Data Path

Figure 4 shows the chip data path in the main operational mode – PCS mode. The various interface configuration are listed in the Interface Modes of Operation table in Section 4. The register settings to set the various configurations are described in Section 4 and Section 5.

Figure 4: 88X5113 Main Operational Modes

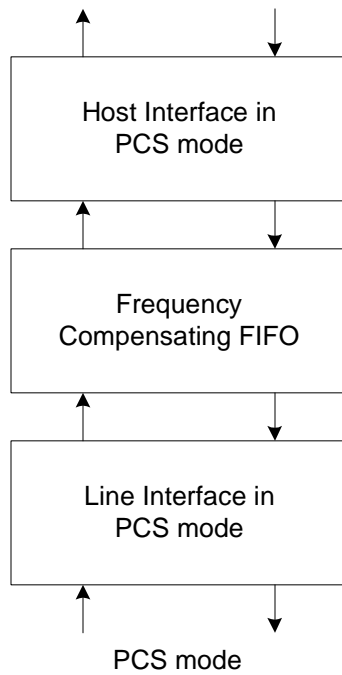

3.1.1 PCS Mode

In the PCS mode, the receive data is terminated by the PCS. The data is retransmitted by a second PCS frequency locked to the local reference clock. The FIFO will insert or delete idles during IPG to compensate for any frequency difference between the received data and the retransmitted data.

While in this mode both the line and host side can enable Auto-Negotiation and perform KR training. The host and line interfaces can mix and match PCS and FEC as long as both sides are running at the same nominal speed. The valid combinations between the host and line configurations are shown in [Table 13](#).

Table 13: Valid PCS Mode Interface Connections

Line	Host
P1X ¹	P1X
P1X	P1P
P1P	P1X
P1S	P1P
P2.5X	P2.5X
P5	P5
P10	P10
P25	P25
P25	P40
P40	P40
P50	P50
P100	P100

1. Refer to the Interface Modes of Operation table in [Section 4](#) for details.

3.2 Reset

A hardware reset (RESETn) will reset the entire chip and initialize all the registers to their hardware reset default.

A software reset has a similar effect on the affected units as a hardware reset except all Retain-type registers will hold their value, and the Update registers will have the previously written values take effect.

All the reset registers described are self-clear with the exception of on-chip processor and on-chip Processor Block reset bits.

Table 14 describes various reset bits available in the device.

Table 14: Reset Bits

Reset Description	Unit Affected	Register – Line	Register – Host
Global Soft-Reset	Whole Chip	31.F404.15	
Global Hard-Reset	Whole Chip	31.F404.14	
On-chip Processor Reset	On-chip Processor only	31.F404.13	
On-chip Processor Block Reset	On-chip Processor whole block	31.F404.12	
Port Soft-Reset This bit soft-reset all the lanes of the respective interface regardless of the interface mode	Port	31.F003.15	31.F003.7
Port Hardware Reset This bit hard-reset all the lanes of the respective interface regardless of the interface mode	Port	31.F003.13	31.F003.5
Per Lane/Interface Mode Soft-Reset In 40G/50G/100G mode, soft-reset to lane 0 will be applied to all lanes (lane 1, 2, and 3 soft-reset bits are ignored).	Lane 0/Aggregated Port Lane 1 Lane 2 Lane 3	3.F000.15 3.F001.15 3.F002.15 3.F003.15	4.F000.15 4.F001.15 4.F002.15 4.F003.15
PMA Soft-Reset In 40G/50G/100G mode, soft-reset to lane 0 will be applied to all lanes (lane 1, 2, and 3 soft-reset bits are ignored).	Lane 0/Aggregated Port Lane 1 Lane 2 Lane 3	1.0000.15 1.2000.15 1.4000.15 1.6000.15	1.1000.15 1.3000.15 1.5000.15 1.7000.15
PCS Soft-Reset – 100G	Lane 0/Aggregated Port	3.0000.15	4.0000.15
PCS Soft-Reset – 40G/50G	Lane 0/Aggregated Port	3.1000.15	4.1000.15
PCS Soft-Reset – 5G/10G/25G	Lane 0/Aggregated Port Lane 1 Lane 2 Lane 3	3.2000.15 3.2200.15 3.2400.15 3.2600.15	4.2000.15 4.2200.15 4.2400.15 4.2600.15
PCS Soft-Reset – 1G/2.5G	Lane 0/Aggregated Port Lane 1 Lane 2 Lane 3	3.3000.15 3.3200.15 3.3400.15 3.3600.15	4.3000.15 4.3200.15 4.3400.15 4.3600.15

Table 14: Reset Bits (Continued)

Reset Description	Unit Affected	Register – Line	Register – Host
802.3AP Auto-negotiation Soft-Reset In 40G/50G/100G mode, soft-reset to lane 0 will be applied to all lanes (lane 1, 2, and 3 soft-reset bits are ignored).	Lane 0/Aggregated Port	7.0000.15	7.1000.15
	Lane 1	7.0200.15	7.1200.15
	Lane 2	7.0400.15	7.1400.15
	Lane 3	7.0600.15	7.1600.15



Note

The Reset table does not include various internal only reset bits.

The Global Hardware Reset register has the same function as the pin reset. It should be issued right after the chip is powered up to make sure the chip starts from a known state. It could be skipped if the pin reset was asserted.

The Port Hardware Reset register resets the line side or host side accordingly. It can be covered by global hardware reset, only apply to one side of the chip, and the same is true for port software reset. This is for debug only.

PMA and PCS software resets are IEEE-compliant registers. They are physically the same but implemented at different register addresses as specified in the IEEE specification. The register will be applied to the corresponding sub-port PCS or the coupled PCS (40G, 100G, or 200G).

During the chip power-on, it is recommended to use global software reset bit or mode software reset bit to apply the configuration (speed, mode) changes. Per lane/interface based mode software reset is often used when changing the operation modes and speeds. They are specifically assigned to the same register as modes setting bits so programming one register can bring up the new mode.

3.3 Hardware Configuration

PHYAD[3:0] and CONFIG[2:0] are sampled at the de-assertion of RESETn. PHYAD[3:0] and CONFIG[2:0] must not change after it is sampled. If PHYAD[3:0] and CONFIG[2:0] change when RESETn is high, then the device will have unpredictable behavior as it enters into an invalid mode. The configuration pins are tied either high or low. The settings are shown in [Table 15](#).

The device will exit reset in a powered down state. Software configuration is then required to get the device into an operational state.

Table 15: Hardware Configuration

Configuration	Setting
PHYAD[3:0]	In MDIO mode, this sets the PHYAD[3:0] setting. PHYAD[4] is set to 0. In TWSI mode, this sets the A[3:0] setting. A[6:4] is set to 100.
CONFIG[0]	Register Access Method 0 = MDIO 1 = TWSI
CONFIG[1]	EEPROM Loading 0 = Do not load EEPROM on startup. 1 = Load EEPROM on startup.
CONFIG[2]	Reserved. Set to 0.

3.4 Register Access

Registers can be accessed either through MDC/MDIO or the TWSI. Only one mode can be enabled at a time and is configured during hardware reset. For either mode, the MDC pins is used for the clock and MDIO is used for data.

3.4.1 IEEE MDC/MDIO Register Access

The management interface provides access to the internal registers via the MDC and MDIO pins and is compliant with IEEE 802.3 Clause 45. MDC is the management data clock input and it can run to a maximum rate of 25 MHz. At high MDIO fanouts, the maximum rate may be decreased depending on the output loading. MDIO is the management data input/output and is a bidirectional signal that runs synchronously to MDC.

PHY address is configured during the hardware reset sequence. Refer to [Section 3.2, Reset, on page 28](#) for detailed information on how to configure PHY addresses.

Typical read and write operations on the management interface are shown in [Figure 5](#) and [Figure 6](#). All the required serial management registers are implemented as well as several optional registers. A description of the registers can be found in the device registers documentation.

Figure 5: Typical MDC/MDIO Read Operation

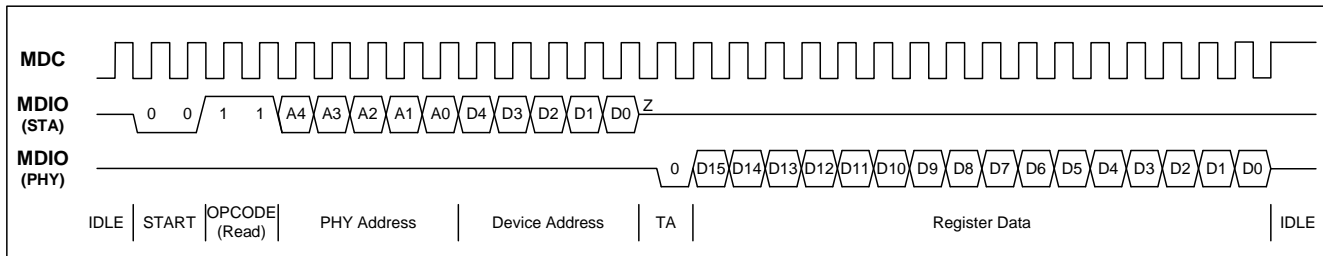
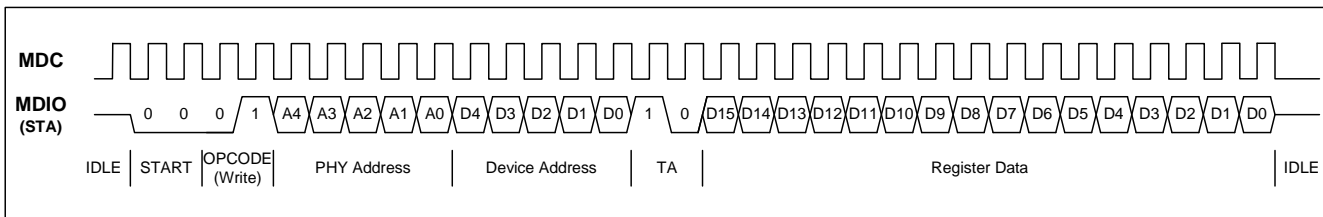

Figure 6: Typical MDC/MDIO Write Operation



The extensions for Clause 45 MDIO indirect register accesses are specified in [Table 16](#).

Table 16: Extensions for Management Frame Format for Indirect Access

Frame	PRE	ST	OP	PHYAD	DEVADR	TA	ADDRESS/DATA	Idle
Address	1...1	00	00	PPPPP	DDDDD	10	AAAAAAAAAAAAAAAA	Z
Write	1...1	00	01	PPPPP	DDDDD	10	DDDDDDDDDDDDDDDD	Z
Read	1...1	00	11	PPPPP	DDDDD	Z0	DDDDDDDDDDDDDDDD	Z
Read Increment	1...1	00	10	PPPPP	DDDDD	Z0	DDDDDDDDDDDDDDDD	Z

The MDIO implements a 16-bit address register that stores the address of the register to be accessed. For an address cycle, it contains the address of the register to be accessed on the next cycle. For read, write, post-read-increment-address cycles, the field contains the data for the register. At power up and reset, the contents of the register are undefined.

Write, read, and post-read-increment-address frames access the address register, though only post-read-increment-address frame modifies the contents of the address register.

3.4.2 TWSI Register Access

Registers can also be accessed over the TWSI. This TWSI interface is a slave interface and should not be confused with the master interface that is used to read the EEPROM. In the following discussion, SSCL represents the clock and SSDA represents the data. This is to avoid confusion with the SCL and SDA pins used to read the EEPROM. When the TWSI mode is enabled, the MDC and MDIO pins correspond to SSCL and SSDA functions.

For the TWSI device address, the address [4:2] bits from pin PHYADR[3:1] are latched during hardware reset and the device address bits ([6:5]) are fixed at 10. The address bits [1:0] is fixed at 00,01,10, and 11 for each 4-lane port.

The TWSI features are as follows:

- 7-bit device address/8-bit data transfers
- 100 Kbps mode (Standard mode, SSCL up to 100 kHz)
- 400 Kbps mode (Fast mode, SSCL up to 400 kHz)

Multiple devices using the TWSI can share and lump up the MDC and MDIO lines and are pulled up with a resistor ranging from 4.5 k Ω to 10 k Ω .

3.4.2.1 Bus Operation

The Master generates one clock pulse for each data bit transferred. The high or low state of the data line can only change when the clock signal on the SSCL line is low. A high to low transition on the SSDA line while SSCL is high defines a Start. A low to high transition on the SSDA line while the SSCL is high defines a Stop. Start (S), Repeated Start (Sr), and Stop (P) conditions are always generated by the Master. Acknowledge (A) and Not Acknowledge (A) can be generated by either the Slave or Master.

The Master continuously monitors for Start and Stop conditions. Whenever a Stop is detected, the device goes into standby mode, and the current operation is canceled. The Slave recovers from this error condition, and waits for the next transfer to begin.

Data transfer with Acknowledge is always obligatory. The receiver must pull down the SSDA line during the Acknowledge clock pulse so that it remains stable low during the high period of this clock pulse.

If the Slave does not Acknowledge the device address, then the Master must abort the transfer. This is indicated by the Slave generating the Not Acknowledge on the first byte to follow. The Slave device then leaves the data line high, and the Master must generate a Stop or a Repeated Start condition. When the Slave is transmitting data on the bus and the Master responds with a Not Acknowledge, the Slave must receive a Stop or a Repeated Start condition. If neither is received, it is an error condition. The Slave recovers from this error condition and waits for the next transfer to begin.

3.4.2.2 Clause 45 Encapsulation

All TWSI transactions will encapsulate PHYAD and DEVAD along with the R/W bit and 3-bit instruction in the first 2 bytes as shown in Figure 7. In all diagrams, the shaded portion is generated by the master and the unshaded portion by the device. The INS[2:0] definition is summarized in Table 17.

Figure 7: First Two Bytes of All Transactions

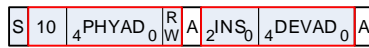

Table 17: INS[2:0] Definition

INS[2:0]	Header	Address
000	Abbreviated Header - Use stored REGAD	Stored REGAD unchanged
001	Abbreviated Header - Use stored REGAD	Post-increment REGAD
010	Full Header - Use specified REGAD	Stored REGAD unchanged
011	Full Header - Use specified REGAD	Post-increment REGAD
100	Dummy Write	
101	Reserved	Reserved
110	Reserved	Reserved
111	Reserved	Reserved

In Clause 45 MDIO access, the REGAD[15:0] is set independently of the data access. There are two methods to specify the REGAD. The first method is to fully specify the REGAD in the transaction as shown in Figure 8, Figure 9, Figure 12, and Figure 13. The second method is to use abbreviated header where the stored REGAD register is used as shown in Figure 10, Figure 11, Figure 14, and Figure 15.

The stored REGAD register is updated on each TWSI transaction. The stored REGAD register can be updated by a dummy write command as shown in Figure 16.

The Clause 45 encapsulation does not differentiate between random versus sequential read/write. All reads and writes can be sustained by the master by not sending a stop bit. So, one or more 16-bit words can be passed with the same encapsulated header. REGAD may or may not be post-incremented after each 16-bit word transfer depending on the INS[2:0].

All 16-bit read/write operations operate atomically. If a write transaction terminates with only 8 bits of the 16-bit word written in, then the 8 bit is discarded and REGAD will not post-increment (if selected). If a read transaction terminates with only 8 bits of the 16-bit word read, then the other 8-bits will be lost forever (that is, in the case of a clear on read register) and REGAD will not post-increment (if selected).

All read transactions must read at least one byte of data. Write transactions can be dummy writes if no data is transferred. If no data is transferred, then no post-incrementing will occur.

The slave will acknowledge the first byte only when PHYAD[4:0] matches and the two most significant bits are 10 (binary).

The slave will acknowledge the second byte only if all the following conditions are met:

- The first byte was acknowledged by the slave.

- The DEVAD[4:0] is among the supported device addresses in the PHY.
 - INS[2] bit is a 0 (that is, it will not respond to reserved instructions).
- The slave will acknowledge the third and subsequent bytes if all the following conditions are met:

- The first and second bytes was acknowledged by the slave.
- The transaction is a write transaction.
- A start bit or stop bit is not detected since the second acknowledge.

The slave will acknowledge the third and fourth bytes if all the following conditions are met:

- The first and second bytes was acknowledged by the slave.
- The instruction indicates a full header is being sent.
- A start bit (not counting the one at the beginning of the current transaction) or stop bit is not detected since the second acknowledge by the slave.

The slave will output 8-bit data if all the following conditions are met:

- The first and second bytes was acknowledged by the slave.
- The third and fourth bytes was acknowledge by the slave if instruction indicates a full header is being sent.
- The transaction is a read transaction.
- A start bit (not counting the one at the beginning of the current transaction), stop bit or no-acknowledge is not detected.

The slave will abort the current 16-bit transfer and will not post-increment the REGAD if a stop bit or no-acknowledge is prematurely detected. All further activities on the bus are ignored by the slave until a start bit is detected.

If the first byte of the REGAD is written and the transaction terminates without the second byte of REGAD being written, then the internal REGAD register will not update.

If a start bit is prematurely detected, then the slave will abort the current 16-bit transfer and will not post-increment the REGAD. This premature start bit will immediately trigger the start of the next I²C transaction.

If post-increment is active and the REGAD is 0xFFFF, then the REGAD will roll over to 0x0000.

Figure 8: Write, Full Header, Retain REGAD

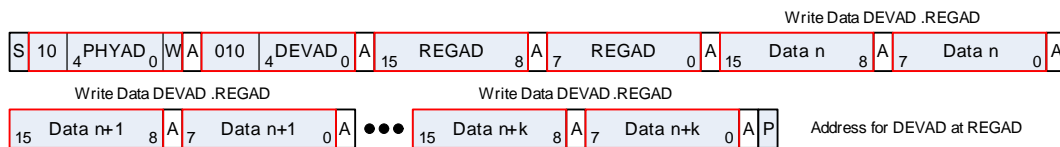

Figure 9: Write, Full Header, Post-Increment

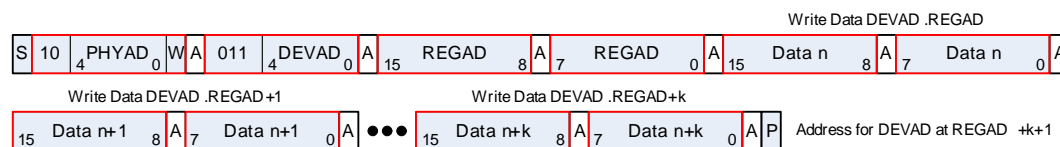

Figure 10: Write, Abbreviated Header, Retain REGAD

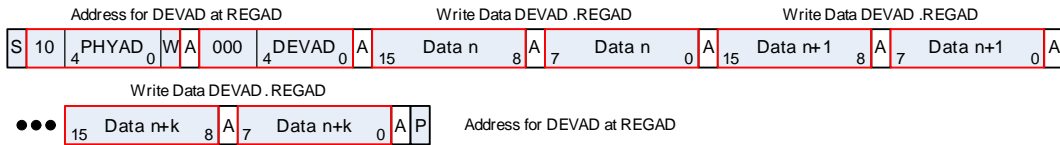

Figure 11: Write, Abbreviated Header, Post-Increment

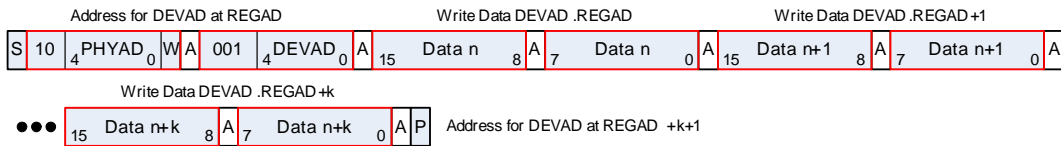

Figure 12: Read, Full Header, Retain REGAD

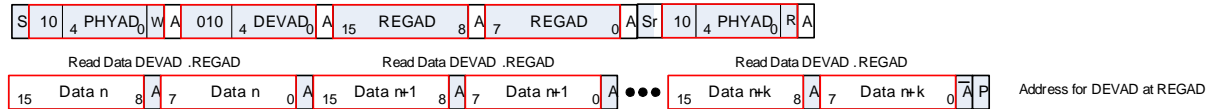

Figure 13: Read, Full Header, Post-Increment

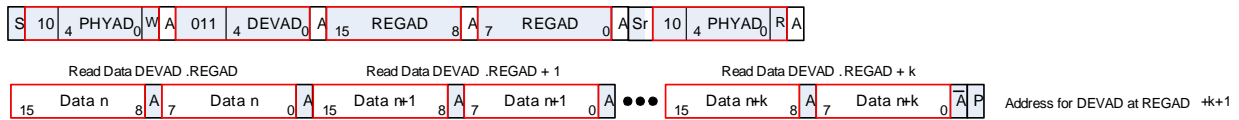

Figure 14: Read, Abbreviated Header, Retain REGAD

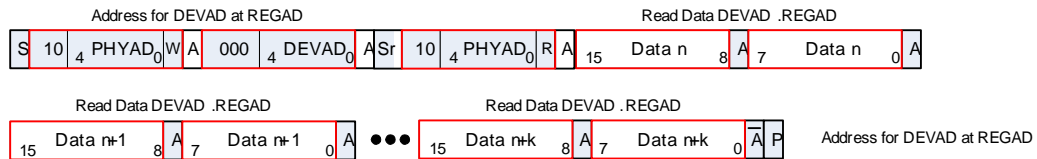

Figure 15: Read, Abbreviated Header, Post-Increment

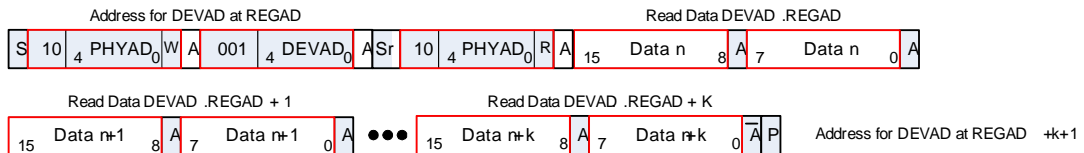
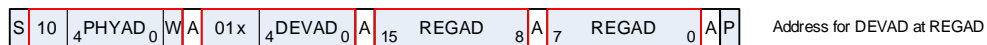

Figure 16: Dummy Write Command to Set REGAD



3.5 TWSI, GPIO, and LED

3.5.1 GPIO[3:0] and LED[3:0]

The GPIO pins are shared between the GPIO and LED functional modes. Each pin can be programmed independently to operate in GPIO or LED modes. The pin mapping is summarized in [Table 18](#).

Table 18: GPIO, LED Signal Mapping

Pin	Special Function	GPIO	LED
GPIO[0]	–	GPIO[0]	LED[0]
GPIO[1]	–	GPIO[1]	LED[1]
GPIO[2]	–	GPIO[2]	LED[2]
GPIO[3]	–	GPIO[3]	LED[3]

GPIO[0] pin is configured to GPIO mode by setting register bits 31.F437.15:14 to 01. This pin can be configured in LED mode by setting register bits 31.F437.15:14 to 10.

The GPIO[3:1] are similar and are configured in GPIO mode by setting register bits 31.F439.15 (for GPIO[1]), 31.F43B.15 (GPIO[2]), and 31.F43D.15 (GPIO[3]) to 0 individually. These pins can be configured in LED mode by setting register bits 31.F439.15 (for GPIO[1]), 31.F43B.15 (GPIO[2]), and 31.F43D.15 (GPIO[3]) to 1 individually.

In GPIO mode, each pin can operate bidirectionally and can be individually configured. In the input mode, these pins can be used as interrupts. The GPIO operations are described in the sections below.

3.5.1.1 Controlling and Sensing

In the GPIO mode, registers 31.F437.13, 31.F439.13, 31.F43B.13, and 31.F43D.13 control whether the GPIO pins are inputs or outputs. Each pin can be individually controlled. Registers 31.F437.7, 31.F439.7, 31.F43B.7, and 31.F43D.7 allow the pins to be controlled and sensed. When configured as input, a read to registers 31.F437.7, 31.F439.7, 31.F43B.7 and 31.F43D.7 will return the real-time sampled state of the pins GPIO[0], GPIO[1], GPIO[2], and GPIO[3], respectively at the time of the read. A write to these register will write to the output register, but have no immediate effect on the pin since the pin is configured to be an input. The input is sampled once every 6.4 ns (equivalent to one reference clock period). When configured as output, a write will write to the output register which will in turn drive the state of the pin. A read to registers 31.F437.7, 31.F439.7, 31.F43B.7, and 31.F43D.7 will return the value in the output registers.

3.5.1.2 GPIO Interrupts

When the GPIO pins are configured as input, several types of interrupt events can be generated as described in [Table 19](#). Register bits 31.F437.10:8, 31.F439.10:8, 31.F43B.10:8, and 31.F43D.10:8 allow each pin to be configured to generate interrupt on one of 5 types of events - Low Level, High Level, High to Low Transition, Low to High Transition, and Transitions on Either Edge. The interrupt generation can also be disabled. When an interrupt event is generated on pin GPIO[0], it is latched

high in the sticky register 31.F437.11. Similarly, when interrupt event is generated on GPIO[1], GPIO[2] or GPIO[3], they are latched in the sticky register 31.F439.11, 31.F43B.11, and 31.F43D.11. The register bits will remain high until read. The GPIO interrupt can be asserted when an event occurs through pins GPIO[3:0]. Registers 31.F437.12, 31.F439.12, 31.F43B.12, and 31.F43D.12 set the interrupt enables.

Registers 31.F437.12 and 31.F437.11 are bitwise AND together to generate a GPIO[0] interrupt. Registers 31.F439.12 and 31.F439.11 are bitwise AND together to generate a GPIO[1] interrupt. Similarly, registers 31.F43B.12 and 31.F43B.11 are bitwise AND together to generate a GPIO[2] interrupt and registers 31.F43D.12 and 31.F43D.11 are bitwise AND together to generate a GPIO[3] interrupt. If the result is non-zero the GPIO interrupt will assert. For interrupt polarity control, refer to [Table 19](#).

Table 19: GPIO/LED Controls

Register	Function	Setting	Mode
31.F437.15:14	GPIO 0 Function	00 = GPIO[0] is used for signaling. 01 = GPIO[0] is used for GPIO 0 function. 10 = GPIO[0] is used for LED 0 function. 11 = Reserved. (LED 0 can only select lane 0 as LED function)	R/W
31.F439.15 31.F43B.15 31.F43D.15	GPIO n Function where n = 1, 2, 3	0 = GPIO [n] pin is used for GPIO 1 function. 1 = GPIO [n] pin is used for LED 1 function. (LED n can only select lane n as LED function)	R/W
31.F437.13 31.F439.13 31.F43B.13 31.F43D.13	LED n Output Enable where n = 0, 1, 2, 3	This bit has no effect unless register 31.F437.15:14 = 01. 0 = Input 1 = Output	R/W
31.F437.12 31.F439.12 31.F43B.12 31.F43D.12	GPIO n Interrupt Enable where n = 0, 1, 2, 3	0 = Disable 1 = Enable	R/W
31.F437.11 31.F439.11 31.F43B.11 31.F43D.11	GPIO n Interrupt Status where n = 0, 1, 2, 3	This bit is not valid unless register 31.F437.15:14 = 01 and 31.F437.13 = 0. 0 = No interrupt has occurred. 1 = An interrupt has occurred.	RO, LH
31.F437.10:8 31.F439.10:8 31.F43B.10:8 31.F43D.10:8	GPIO n Interrupt Select where n = 0, 1, 2, 3	Interrupt is effective only when 31.F437.13 = 0. 000 = No Interrupt 001 = Reserved 010 = Interrupt on Low Level 011 = Interrupt on High Level 100 = Interrupt on High to Low 101 = Interrupt on Low to High 110 = Reserved 111 = Interrupt on Low to High or High to Low	R/W

Table 19: GPIO/LED Controls (Continued)

Register	Function	Setting	Mode
31.F437.7 31.F439.7 31.F43B.7 31.F43D.7	GPIO n Data where n = 0, 1, 2,3	This bit has no effect unless register 31.F437.15:14 = 01. When 31.F437.13 = 0, a read to this register will reflect the state of the GPIO[0], and a write will write the output register but have no effect on the GPIO[n]. When 31.F437.13 = 1 a read to this register will reflect the state of the output register, and a write will write the output register and drive the state of the GPIO[n].	R/W
31.F437.6:0 31.F439.6:0 31.F43B.6:0 31.F43D.6:0	Reserved	Set to 0s.	RO

3.5.1.3 LED

The GPIO[3:0] pins can be used to drive LED pins. Setting register 31.F437.15:14 to 10 and registers 31.F439.15, 31.F43B.15, and 31.F43D.15 to 1 will configure the GPIO[0], GPIO[1], GPIO[2], GPIO[3] pin in the LED mode and named as LED[0], LED[1], LED[2] and LED[3]. Registers 31.F438, 31.F43A, 31.F43C, and 31.F43E control the operation of the LED pins. LED[3:0] will operate per this section unless the pin is used for GPIO purposes. Figure 17 shows the general chaining of function for the LEDs. The various functions are described in the following sections. All LED pins are tri-state outputs.

Figure 17: LED Chain

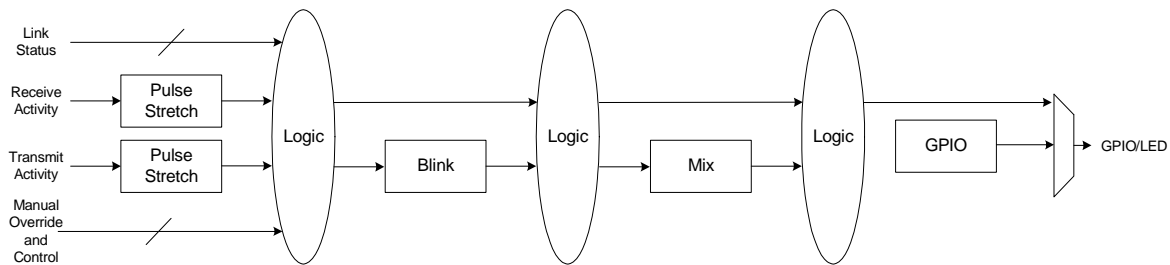

LED Operations

The LED pins relay various statuses of the PHY so that they can be displayed by the LEDs.

The status that the LEDs display is defined by registers 31.F438, 31.F43A, 31.F43C, and 31.F43E as shown in Table 20. For each LED, if the condition selected by bits 11:8 is true, then the LED will blink. If the condition selected by bits 7:4 is true, then the LED will be solid on. If both selected conditions are true, then the blink will take precedence.

LED0 displays the status of lane 0, and LED1 displays the status of lane 1, and so on. Register bit 31.F438.12 is set to 1 to display the status of system (host) side transmit activity, receive activity and link status register on LED 0. Setting 31.F438.12 to 0 will display the status of line side on LED 0. Similarly, register bits 31.F43A.12, 31.F43C.12, and 31.F43E.12 are used to select the status of the host side or the line side for LED1, LED2, and LED3.

LED Polarity

There are a variety of methods to hook up the LEDs. Some examples are shown in [Figure 18](#). Registers 31.F438.1:0, 31.F43A.1:0, 31.F43C.1:0, and 31.F43E.1:0 specify the output polarity for the LED function to accommodate a variety of installation options. The lower bit of each pair specifies the on (active) state of the LED, either high or low. The upper bit of each pair specifies whether the off state of the LED should be driven to the opposite level of the on state or Hi-Z.

Figure 18: Various LED Hookup Configurations

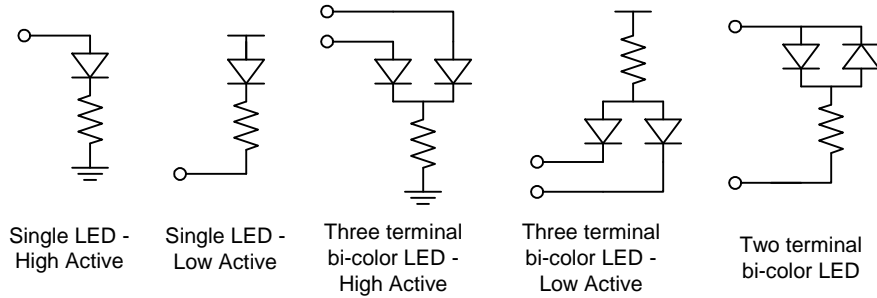

Table 20: LED[3:0] Control and Status Register Bits

Register	Function	Setting	Mode
31.F438.15:13 31.F43A.15:13 31.F43C.15:13 31.F43E.15:13	Reserved	Scratch reserved register	R/W
31.F438.12 31.F43A.12 31.F43C.12 31.F43E.12	LED[n] PHY/System side select Where n = 0, 1, 2, 3	0 = PHY side (line side). 1 = System side (host side).	R/W
31.F438.11:8 31.F43A.11:8 31.F43C.11:8 31.F43E.11:8	LED[n] Blink Behavior Where n = 0, 1, 2, 3	Blink Behavior has higher priority. 0000 = Solid Off 0001 = System or Line Side Transmit or Receive Activity 0010 = System or Line Side Transmit Activity 0011 = System or Line Side Receive Activity 0100 = Reserved 0101 = Reserved 0110 = System or Line Side Side Link 0111 = Solid On 1000 = Reserved 1001 = Reserved 1010 = Blink Mix 1011 = Solid Mix 11xx = Reserved	R/W

Table 20: LED[3:0] Control and Status Register Bits (Continued)

Register	Function	Setting	Mode
31.F438.7:4 31.F43A.7:4 31.F43C.7:4 31.F43E.7:4	LED[n] Solid Behavior Where n = 0, 1, 2, 3	Blink Behavior has higher priority. 0000 = Solid Off 0001 = System or Line Side Transmit or Receive Activity 0010 = System or Line Side Transmit Activity 0011 = System or Line Side Receive Activity 0100 = Reserved 0101 = Reserved 0110 = System or Line Side Link 0111 = Solid On 1xxx = Reserved	R/W
31.F438.3 31.F43A.3 31.F43C.3 31.F43E.3	Reserved	Set to 0.	R/W
31.F438.2 31.F43A.2 31.F43C.2 31.F43E.2	LED[n] Blink Rate Select Where n = 0, 1, 2, 3	0 = Select Blink Rate 1 1 = Select Blink Rate 2	R/W
31.F438.1:0 31.F43A.1:0 31.F43C.1:0 31.F43E.1:0	LED[n] Polarity Where n = 0, 1, 2, 3	00 = On - drive LED[n] low, Off - drive LED[n] high 01 = On - drive LED[n] high, Off - drive LED[n] low 10 = On - drive LED[n] low, Off - tri-state LED[n] 11 = On - drive LED[n] high, Off - tri-state LED[n]	

Pulse Stretching and Blinking

Register 31.F435.14:12 specifies the pulse stretching duration for a particular activity. Only the transmit activity, receive activity, and (transmit or receive) activity are stretched. All other statuses are not stretched since they are static in nature and no stretching is required.

Some status will require blinking instead of a solid on. Registers 31.F435.10:8 and 31.F435.6:4 specify the two blink rates. The pulse stretching is applied first and the blinking will reflect the duration of the stretched pulse. Registers 31.F438.2, 31.F43A.2, 31.F43C.2, and 31.F43E.2 select which of the two blink rates to use for LED0 to LED3, respectively.

- 0 = Select Blink Rate 1.
- 1 = Select Blink Rate 2.

Table 21: LED Timer Control

Register	Function	Setting	Mode
31.F435.15	Reserved	Set to 0.	R/W

Table 21: LED Timer Control (Continued)

Register	Function	Setting	Mode
31.F435.14:12	Pulse Stretch Duration	000 = No pulse stretching 001 = 20 to 40 ms 010 = 40 to 81 ms 011 = 81 to 161 ms 100 = 161 to 322 ms 101 = 322 to 644 ms 110 = 644 ms to 1.3s 111 = 1.3 to 2.6s	R/W
31.F435.11	Reserved	Set to 0.	R/W
31.F435.10:8	Blink Rate 2	000 = 40 ms 001 = 81 ms 010 = 161 ms 011 = 322 ms 100 = 644 ms 101 = 1.3s 110 = 2.6s 111 = 5.2s	R/W
31.F435.7	Reserved	Set to 0.	R/W
31.F435.6:4	Blink Rate 1	000 = 40 ms 001 = 81 ms 010 = 161 ms 011 = 322 ms 100 = 644 ms 101 = 1.3s 110 = 2.6s 111 = 5.2s	R/W
31.F435.3:0	Reserved	Set to 0.	R/W

3.5.2 TWSI, GPIO 4, and GPIO 5

The SCL and SDA pins are for TWSI mode and have the option to be used for GPIO functional mode. In TWSI mode, the SCL and SDA pins are coupled together, where the SCL pin is used as a clock, and SDA is used as a serial bidirectional data. The pin mapping is summarized in [Table 22](#).

Table 22: TWSI and GPIO Signal Mapping

Pin	GPIO	TWSI
SCL	GPIO[4]	TWSI clock (SCL)
SDA	GPIO[5]	TWSI serial data (SDA)

The SCL and SDA pins are configured to TWSI mode by setting 31.F430.14 to 0. TWSI is the default mode for these pins. SCL pin is configured in GPIO mode by setting register bits 31.F430.14 to 1. Similarly, SDA pin is configured in GPIO mode by setting register bits 31.F432.14 to 1.

TWSI is the two-wire serial interface standard. In a special mode, TWSI is used to load the SERDES and chip management firmware from an external EEPROM immediately after the reset is de-asserted. EEPROM is attached to the TWSI interface via the SCL and SDA pins. This interface can also be used to write the external EEPROM from an internal RAM using the embedded processor.

Table 23: SCL Control

Register	Function	Setting	Mode
31.F430.15	Reserved	Reserved	RO
31.F430.14	SCL Function	TWSI mode for SCL and SDA pins are selected by 31.F430.14 only. Register 31.F432.14 has no effect on TWSI mode. GPIO functions are controlled individually for each pin. 0 = SCL/SDA is used for TWSI Function. 1 = SCL is used for GPIO Function, if 31.F427.7 = 0. 1 = SCL is used for divided recovered clock B, when 31.F427.7 = 1.	R/W
31.F430.13	SCL Output Enable	This bit has no effect unless register 31.F430.14 = 1 and 31.F427.7 = 0. 0 = Input 1 = Output	R/W
31.F430.12	SCL Interrupt Enable	0 = Disable 1 = Enable	R/W
31.F430.11	SCL Interrupt Status	This bit is not valid unless register 31.F430.14 = 1 and 31.F430.13 = 0. 0 = No interrupt has occurred. 1 = An interrupt has occurred.	RO, LH

Table 23: SCL Control (Continued)

Register	Function	Setting	Mode
31.F430.10:8	SCL Interrupt Select	Interrupt is effective only when 31.F430.13 = 0. 000 = No Interrupt 001 = Reserved 010 = Interrupt on Low Level 011 = Interrupt on High Level 100 = Interrupt on High to Low 101 = Interrupt on Low to High 110 = Reserved 111 = Interrupt on Low to High or High to Low	R/W
31.F430.7	SCL GPIO Data	This bit has no effect unless register 31.F430.14 = 1. When 31.F430.13 = 0, a read to this register will reflect the state of the SCL pin, and a write will write the output register but have no effect on the SCL pin. When 31.F430.13 = 1, a read to this register will reflect the state of the output register, and a write will write the output register and drive the state of the SCL pin.	R/W
31.F430.6:0	Reserved	Set to 0s.	RO

Table 24: SDA Control

Register	Function	Setting	Mode
31.F432.15	Reserved	Reserved.	RO
31.F432.14	SDA Function	TWSI mode for SCL and SDA pins are selected by 31.F430.14 only. Register 31.F432.14 has no effect on TWSI mode, but can enable the GPIO or Recovered clock output function on this pin. 0 = Reserved 1 = SDA is used for GPIO 5 Function if 31.F427.11 = 0. 1 = SDA is used for divided recovered clock C if 31.F427.11 = 1.	R/W
31.F432.13	SDA Output Enable	This bit has no effect unless register 31.F432.14 = 1 and register 31.LT27.11 = 0. 0 = Input 1 = Output	R/W
31.F432.12	SDA Interrupt Enable	0 = Disable 1 = Enable	R/W
31.F432.11	SDA Interrupt Status	This bit is not valid unless register 31.F432.14 = 1 and register 31.F432.13 = 0. 0 = No interrupt has occurred. 1 = An interrupt has occurred.	RO, LH

Table 24: SDA Control (Continued)

Register	Function	Setting	Mode
31.F432.10:8	SDA Interrupt Select	Interrupt is effective only when 31.F432.13 = 0. 000 = No Interrupt 001 = Reserved 010 = Interrupt on Low Level 011 = Interrupt on High Level 100 = Interrupt on High to Low 101 = Interrupt on Low to High 110 = Reserved 111 = Interrupt on Low to High or High to Low	R/W
31.F432.7	SDA GPIO Data	This bit has no effect unless register 31.F432.14 = 1. When 31.F432.13 = 0, a read to this register will reflect the state of the SDA pin, and a write will write the output register but have no effect on the SDA pin. When 31.F432.13 = 1, a read to this register will reflect the state of the output register, and a write will write the output register and drive the state of the SDA pin.	R/W
31.F432.6:0	Reserved	Set to 0s.	RO

Table 25: I/O Open Drain Control

Register	Function	Setting	Mode
Port0 31.F436.15:3	Reserved	Set to 0.	R/W
Port0 31.F436.2	GPIO1 pin (port0 GPIO[0]) open drain control	0 = Pad can drive high. 1 = Pad cannot drive high (Set to high when open drain pad is used).	R/W
Port0 31.F436.1:0	Reserved	Set to 0.	R/W
Port1 31.F436.15:7	Reserved	Set to 0.	R/W
Port1 31.F436.6	GPIO2 pin (port1 GPIO[4]) open drain control	0 = Pad can drive high. 1 = Pad cannot drive high (Set to high when open drain pad is used).	R/W
Port1 31.F436.5:4	Reserved	Set to 0.	R/W
Port2 31.F436.15:3	Reserved	Set to 0.	R/W
Port2 31.F436.2	GPIO3 pin (port2 GPIO[0]) open drain control	0 = Pad can drive high. 1 = Pad cannot drive high (Set to high when open drain pad is used).	R/W
Port2 31.F436.1:0	Reserved	Set to 0.	R/W
Port3 31.F436.7	CLK_OUT_SE2 pin (port3 GPIO[5]) open drain control	0 = Pad can drive high. 1 = Pad cannot drive high (Set to high when open drain pad is used).	R/W
Port3 31.F436.6	CLK_OUT_SE1 pin (port3 GPIO[4]) open drain control	0 = Pad can drive high. 1 = Pad cannot drive high (Set to high when open drain pad is used).	R/W
Port3 31.F436.5	Reserved	Set to 0.	R/W
Port3 31.F436.4	GPIO4 pin (port3 GPIO[2]) open drain control	0 = Pad can drive high. 1 = Pad cannot drive high (Set to high when open drain pad is used).	R/W
Port3 31.F436.3:0	Reserved	Set to 0.	R/W

3.5.3 Two-wire Serial Interface (TWSI)

TWSI is used to load the SERDES and chip management firmware from an external EEPROM. EEPROM is attached to the TWSI interface via the SCL and SDA pins. This interface can also be used to write the external EEPROM from an internal RAM using the embedded processor. External pull up resistors are required to connect to SCL and SDA pins.

3.6 Interrupt

Various functional units in the device can generate interrupt on the INTn pin. The INTn interrupt pin will be active if any of the events enabled in the interrupt enable register occurs. If an interrupt event corresponding to a disabled interrupt enable bit occurs, then the corresponding interrupt status bit will be set even though the event does not activate the INTn pin.

By default, the INTn is driven low when an enabled interrupt is active. The polarity of the INTn pin can be changed by programming register 31.F421.2:1. The INTn pin can also be forced to be active by setting the register 31.F421.0 to 1.

Table 26: Global Interrupt Control

Register	Function	Setting
31.F421.2:1	Interrupt Polarity	00 = Active - drive INT low, Inactive - drive INT high 01 = Active - drive INT high, Inactive - drive INT low 10 = Active - drive INT low, Inactive - tri-state INT 11 = Active - drive INT high, Inactive - tri-state INT
31.F421.0	Force Interrupt Pin Active	0 = Normal operation 1 = Force interrupt pin active.

The interrupts are cleared after a read to the interrupt status register. F

The Global Interrupt Status register ([Table 27](#)) summarizes which unit is requesting the interrupt. The interrupts are logically ORed along with register 31.F421.0 to form the interrupt output (INTn). The Global Interrupt Status register bits do not have corresponding Interrupt Enable bits. All the interrupt enables/masks are located within each unit.

Figure 19 diagram shows the interrupt hierarchy and aggregation from different blocks.

Figure 19: Interrupt Hierarchy and Aggregation from Different Blocks

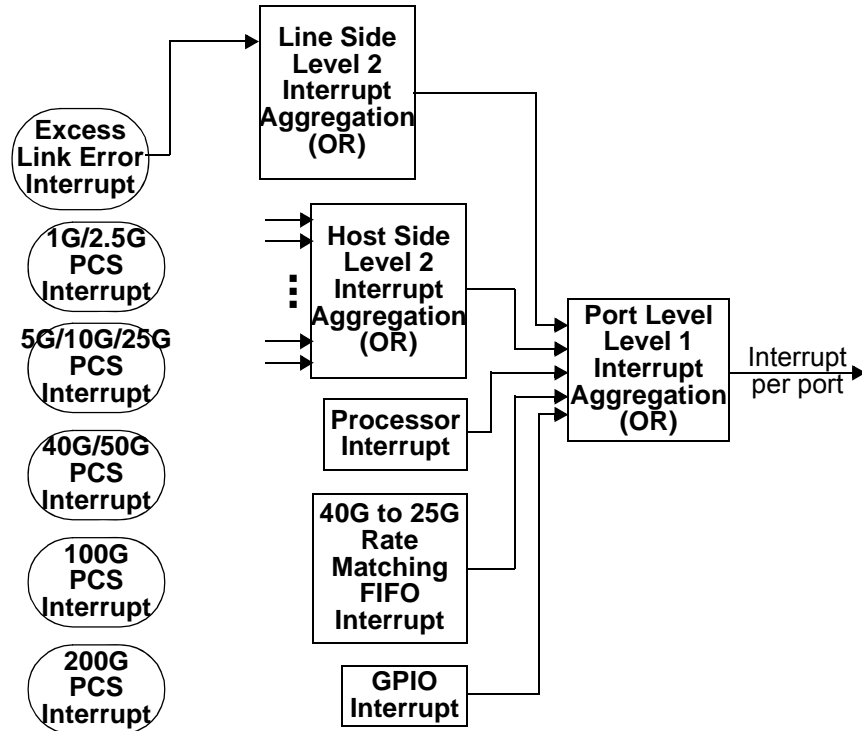

Table 27: Global Interrupt Status

Bit Descriptions	Register
Temp Sensor Interrupt Status	31.F420.11
GPIO Interrupt Status	31.F420.10
RM_FIFO Interrupt Status	31.F420.9
On-chip Processor Interrupt Status	31.F420.8
M0 Interrupt Status	31.F420.4
N0 Interrupt Status	31.F420.0

Table 28, Table 29, Table 30, and Table 31 summarize the Line Side (N Unit) interrupt control and statuses for various interface modes. Excessive link error can be monitored to generate an interrupt event (See Table 32).

The Host Side (M Unit) has the same set of interrupt function with the exception that the device register is 4 (instead of 3).

Each bit of the Interrupt Status register will be masked with the Interrupt Enable register, respectively, and each enabled output is ORed to form the aggregated unit interrupt. The Port Interrupt Statuses (register 31.F004.0 – Line Side Interrupt, register 31.F004.2 – System Side Interrupt) are the result of logical OR of the aggregated unit interrupt.

Table 28: 1G/2.5G Interrupt Enable, Interrupt Status, and Real-Time Status

Bit Descriptions	Interrupt Enable	Interrupt Status	Real-Time Status
Speed Changed	3.Bn01.14	3.Bn02.14	–
Duplex Changed	3.Bn01.13	3.Bn02.13	–
Page Received	3.Bn01.12	3.Bn02.12	–
Auto-Negotiation Completed	3.Bn01.11	3.Bn02.11	–
Link Up to Link Down	3.Bn01.10	3.Bn02.10	–
Link Down to Link Up	3.Bn01.9	3.Bn02.9	–
Symbol Error	3.Bn01.8	3.Bn02.8	–
False Carrier	3.Bn01.7	3.Bn02.7	–

Where n = 0, 2, 4, 6 for Lane 0, 1, 2, and 3, respectively.

Table 29: 10G/25G Interrupt Enable, Interrupt Status, and Real-Time Status

Bit Descriptions	Interrupt Enable	Interrupt Status	Real-Time Status
Local Fault Transmitted	3.An00.11	3.An01.11	3.An02.11
Local Fault Received	3.An00.10	3.An01.10	3.An02.10
Rx FIFO Full	3.An00.6	3.An01.6	3.An02.6
Rx FIFO Empty	3.An00.5	3.An01.5	3.An02.5
Link Status Change	3.An00.2	3.An01.2	3.An02.2
High BER Change	3.An00.1	3.An01.1	3.An02.1
Block Lock Change	3.An00.0	3.An01.0	3.An02.0
CRC	3.An4A.2	3.An4B.2	–
FIFO Overflow	3.An4A.1	3.An4B.1	–
FIFO Underflow	3.An4A.0	3.An4B.0	–

Where n = 0, 2, 4, 6 for Lane 0, 1, 2, and 3, respectively.

Table 30: 40G/50G Interrupt Enable, Interrupt Status, and Real-Time Status

Bit Descriptions	Interrupt Enable	Interrupt Status	Real-Time Status
Local Fault Transmitted	3.9001.11	3.9002.11	3.9003.11
Local Fault Received	3.9001.10	3.9002.10	3.9003.10
Lane Alignment	3.9001.9	3.9002.9	3.9003.9
Tx Lane Count err	3.9001.8	3.9002.8	3.9003.8
JIT 0 Lock Change	3.9001.7	3.9002.7	3.9003.7
JIT Local-Fault Lock Change	3.9001.6	3.9002.6	3.9003.6
Link Status Change	3.9001.5	3.9002.5	3.9003.5
High BER Change	3.9001.4	3.9002.4	3.9003.4
Lane 3:0 Block Lock Change	3.9001.3:0	3.9002.3:0	3.9003.3:0
CRC	3.904A.2	3.904B.2	–
FIFO Overflow	3.904A.1	3.904B.1	–
FIFO Underflow	3.904A.0	3.904B.0	–

Where n = 0, 2, 4, 6 for Lane 0, 1, 2, and 3, respectively.

Table 31: 100G Interrupt Enable, Interrupt Status, and Real-Time Status

Bit Descriptions	Interrupt Enable	Interrupt Status	Real-Time Status
100G PCS Rx FIFO Empty	3.8001.15	3.8003.15	3.8005.15
100G PCS Rx FIFO Full	3.8001.14	3.8003.14	3.8005.14
100G PCS Tx PPM FIFO Overflow	3.8001.13	3.8003.13	3.8005.13
100G PCS Tx PPM FIFO Underflow	3.8001.12	3.8003.12	3.8005.12
Rising Edge of the Local Fault Condition on Tx Path	3.8001.11	3.8003.11	3.8005.11
Rising Edge of the Local Fault Condition on Rx Path	3.8001.10	3.8003.10	3.8005.10
100G Packet Check CRC Error	3.8001.7	3.8003.7	3.8005.7
Link Change	3.8001.5	3.8003.5	3.8005.5
High BER Change	3.8001.4	3.8003.4	3.8005.4
Lane 3:0 Block Lock Change	3.8001.3:0	3.8003.3:0	3.8005.3:0
Lane 19:4 Block Lock Change	3.8002.15:0	3.8004.15:0	3.8006.15:0

Where n = 0, 2 for Lane 0, 2, respectively.

Table 32: Excessive Link Error Interrupt Enable, Interrupt Status, and Real-Time Status

Bit Descriptions	Interrupt Enable	Interrupt Status	Real-Time Status
Excessive Link Error – Lane 0 In 40G/50G/100G mode, only Lane 0 interrupt is used (Lane 1, 2, and 3 interrupts bits are ignored). Register 3.F041.6:0 sets the link error threshold setting. Register 3.F041.7 sets the link down or link up error setting.	3.F041.8	3.F040.15	3.F040.14
Excessive Link Error – Lane 1 Register 3.F043.6:0 sets the link error threshold setting. Register 3.F043.7 sets the link down or link up error setting.	3.F043.8	3.F042.15	3.F042.14
Excessive Link Error – Lane 2 Register 3.F045.6:0 sets the link error threshold setting. Register 3.F045.7 sets the link down or link up error setting.	3.F045.8	3.F044.15	3.F044.14
Excessive Link Error – Lane 3 Register 3.F047.6:0 sets the link error threshold setting. Register 3.F047.7 sets the link down or link up error setting.	3.F047.8	3.F046.15	3.F046.14

The interrupt from the processor block is for debug or patch program: details are not provided here (For further details, refer to [Section 3.10](#)).

All of the GPIO interrupts are only valid when the multi-function pins are configured as GPIO Inputs.

Table 33: GPIO1, GPIO2, GPIO3, GPIO4, CLK_OUT_SE1, CLK_OUT_SE2 Pins Interrupt

Bit Descriptions	Interrupt Enable	Interrupt Status	Real-Time Status
GPIO1 Pin (Port0, GPIO[0]) Valid only when register port0.31.F437.15:14 = 01 and port0.31.F437.13 = 0. Register port0.31.F437.10:8 is used to select the interrupt behavior.	port0. 31.F437.12	port0. 31.F437.11	port0. 31.F437.7
GPIO2 Pin (Port1, GPIO[4]) Valid only when register port1.31.F430.15:14 = 01 and port1.31.F430.13 = 0. Register port1.31.F430.10:8 is used to select the interrupt behavior.	port1. 31.F430.12	port1. 31.F430.11	port1. 31.F430.7
GPIO3 Pin (Port2, GPIO[0]) Valid only when register port2.31.F437.15:14 = 01 and port2.31.F437.13 = 0. Register port2.31.F437.10:8 is used to select the interrupt behavior.	port2. 31.F437.12	port2. 31.F437.11	port2. 31.F437.7
GPIO4 Pin (Port3, GPIO[2]) Valid only when register port3.31.F43B.15:14 = 01 and port3.31.F43B.13 = 0. Register port3.31.F43B.10:8 is used to select the interrupt behavior.	port3. 31.F43B.12	port3. 31.F43B.11	port3. 31.F43B.7
CLK_OUT_SE1 Pin (Port3, GPIO[4]) Valid only when register port3.31.F430.15:14 = 01 and port3.31.F430.13 = 0. Register port3.31.F430.10:8 is used to select the interrupt behavior.	port3. 31.F430.12	port3. 31.F430.11	port3. 31.F430.7
CLK_OUT_SE2 Pin (Port3, GPIO[5]) Valid only when register port3.31.F432.15:14 = 01 and port3.31.F432.13 = 0. Register port3.31.F432.10:8 is used to select the interrupt behavior.	port3. 31.F432.12	port3. 31.F432.11	port3. 31.F432.7

Table 34 summarizes the temperature sensor and GPIOs interrupt.

Table 34: Temp Sensor and GPIOs, Interrupt Enable, Interrupt Status

Bit Descriptions	Interrupt Enable	Interrupt Status	Real-Time Status
Temperature Sensor Register 31.F707.15:8 sets the temperature threshold.	31.F41F.15	31.F705.6	See the Temp Sensor section.

Table 34: Temp Sensor and GPIOs, Interrupt Enable, Interrupt Status (Continued)

Bit Descriptions	Interrupt Enable	Interrupt Status	Real-Time Status
GPIO 0 (LED 0) Valid only when register 31.F437.15:14 = 01 and 31.F437.13 = 0. Register 31.F437.10:8 is used to select the interrupt behavior.	31.F437.12	31.F437.11	31.F437.7
GPIO 1 (LED 1) Valid only when register 31.F439.15=0 and 31.F439.13 = 0. Register 31.F439.10:8 is used to select the interrupt behavior.	31.F439.12	31.F439.11	31.F439.7
GPIO 2 (LED 2) Valid only when register 31.F43B.15=0 and 31.F43B.13 = 0. Register 31.F43B.10:8 is used to select the interrupt behavior.	31.F43B.12	31.F43B.11	31.F43B.7
GPIO 3 (LED 3) Valid only when register 31.F43D.15=0 and 31.F43D.13 = 0. Register 31.F43D.10:8 is used to select the interrupt behavior.	31.F43D.12	31.F43D.11	31.F43D.7
GPIO 4 (SCL) Valid only when register 31.F430.14 = 1, 31.F427.7 = 0, and 31.F430.13 = 0. Register 31.F430.10:8 is used to select the interrupt behavior.	31.F430.12	31.F430.11	31.F430.7
GPIO 5 (SDA) Valid only when register 31.F432.14 = 1, 31.F427.11 = 0, and 31.F432.7 = 0. Register 31.F432.10:8 is used to select the interrupt behavior.	31.F432.12	31.F432.11	31.F432.7

3.7 Power Management

The device will exit reset in a powered down state.

In general, it is not necessary to power down an unused interface. The device will automatically power down any unused circuits. Each of the ports or blocks can be manually powered down by setting the respective power down control bits as described in [Table 35](#).

To prevent fragmentation, the power down control function is designed to wait until the datapath is IDLE with the exception of Per Lane/Interface Mode Power Down control bits that are activated immediately and may cause fragmentation in the datapath.

Table 35: Power Down Control Bits

Power Down Bits Description	Unit Affected	Register – Line	Register – Host
Port Power Down This bit power-down all the lanes of the respective interface regardless of the interface mode.	Port	31.F003.14	31.F003.6
Per Lane/Interface Mode Power Down In 40G/50G/100G mode, power-down to lane 0 will be applied to all lanes (Lane 1, 2, and 3 power-down bits are ignored).	Lane 0/Aggregated Port Lane 1 Lane 2 Lane 3	3.F000.13 3.F001.13 3.F002.13 3.F003.13	4.F000.13 4.F001.13 4.F002.13 4.F003.13
PMA Power Down In 40G/50G/100G mode, power-down to lane 0 will be applied to all lanes (Lane 1, 2, and 3 power-down bits are ignored).	Lane 0/Aggregated Port Lane 1 Lane 2 Lane 3	1.0000.11 1.2000.11 1.4000.11 1.6000.11	1.1000.11 1.3000.11 1.5000.11 1.7000.11
PCS Power-Down – 100G	Lane 0/Aggregated Port (lane 0-3 coupled)	3.0000.11	4.0000.11
PCS Power-Down – 40G/50G	Lane 0/Aggregated Port (lane 0-3 coupled)	3.1000.11	4.1000.11
PCS Power-Down – 5G/10G/25G	Lane 0/Aggregated Port Lane 1 Lane 2 Lane 3	3.2000.11 3.2200.11 3.2400.11 3.2600.11	4.2000.11 4.2200.11 4.2400.11 4.2600.11
PCS Power-Down – 1G/2.5G	Lane 0/Aggregated Port Lane 1 Lane 2 Lane 3	3.3000.11 3.3200.11 3.3400.11 3.3600.11	4.3000.11 4.3200.11 4.3400.11 4.3600.11

Registers 3.F000 through 3.F003 or 4.F000 through 4.F003 define the operation modes for fixed mode. The power down bit 13 of them is only to be used for fixed mode. When Aneg is enabled, these registers are ignored.

3.8 IEEE 1149.1 and 1149.6 Controller

The IEEE 1149.1 standard defines a test access port and boundary-scan architecture for digital integrated circuits and for the digital portions of mixed analog/digital integrated circuits. The IEEE 1149.6 standard defines a test access port and boundary-scan architecture for AC-coupled signals.

This standard provides a solution for testing assembled printed circuit boards and other products based on highly complex digital integrated circuits and high-density surface-mounting assembly techniques.

The device implements the instructions shown in [Table 36](#). Upon reset, ID_CODE instruction is selected. The instruction opcodes are shown in [Table 36](#).

Table 36: TAP Controller Opcodes

Instruction	OpCode
EXTEST	00_0x0
SAMPLE/PRELOAD	00_0000_0001
CLAMP	00_0000_0010
HIGH-Z	00_0000_0011
ID_CODE	00_0000_0100
EXTEST_PULSE	00_0000_0101
EXTEST_TRAIN	00_0000_0110
BYPASS	11_1111_1111

The device reserves five pins called the Test Access Port (TAP) to provide test access:

- Test Mode Select Input (TMS)
- Test Clock Input (TCK)
- Test Data Input (TDI)
- Test Data Output (TDO)
- Test Reset Input (TRSTn)

To ensure race-free operation all input and output data is synchronous with the test clock (TCK). TAP input signals (TMS and TDI) are clocked into the test logic on the rising edge of TCK, while output signal (TDO) is clocked on the falling edge. For additional details refer to the IEEE 1149.1 Boundary Scan Architecture document.

3.8.1 BYPASS Instruction

The BYPASS instruction uses the bypass register. This register contains a single shift-register stage and is used to provide a minimum length serial path between the TDI and TDO pins of the 88X5113 device when test operation is not required. This arrangement allows rapid movement of test data to and from other testable devices in the system.

3.8.2 SAMPLE/PRELOAD Instruction

The SAMPLE/PRELOAD instruction enables scanning of the boundary-scan register without causing interference to the normal operation of the device. Two functions are performed when this instruction is selected: sample and preload.

Sample allows a snapshot to be taken of the data flowing from the system pins to the on-chip test logic or vice versa, without interfering with normal operation. The snapshot is taken on the rising edge of TCK in the Capture-DR controller state, and the data can be viewed by shifting through the component's TDO output.

While sampling and shifting data out through TDO for observation, preload enables an initial data pattern to be shifted in through TDI and to be placed at the latched parallel output of the boundary-scan register cells that are connected to system output pins. This step ensures that known data is driven through the system output pins upon entering the extest instruction. Without preload, indeterminate data would be driven until the first scan sequence is complete. The shifting of data for the sample and preload phases can occur simultaneously. While data capture is being shifted out, the preload data can be shifted in.

The boundary scan register for CONFIG[2] is closest to TDO.

Table 37 lists the boundary scan order where:

TDI → LIN[0] → ... → CONFIG[2] → TDO

Table 37: Boundary Scan Chain Order

Order	Ball	Type
1	CONFIG[2]	Input
2	CONFIG[1]	Input
3	CONFIG[0]	Input
4	PHYAD[2]	Input
5	PHYAD[3]	Input
6	PHYAD[1]	Input
7	PHYAD[0]	Input
8	INTN	Output
9	INTN	Output Enable
10	MDC	Input
11	MDIO	Input
12	MDIO	Output
13	MDIO	Output Enable
14	HOP[3]	AC Output
15	HON[3]	AC Output
16	HIP[3]	AC Input
17	HIN[3]	AC Input

Table 37: Boundary Scan Chain Order (Continued)

Order	Ball	Type
18	HOP[2]	AC Output
19	HON[2]	AC Output
20	HIP[2]	AC Input
21	HIN[2]	AC Input
22	HOP[1]	AC Output
23	HON[1]	AC Output
24	HIP[1]	AC Input
25	HIN[1]	AC Input
26	HOP[0]	AC Output
27	HON[0]	AC Output
28	HIP[0]	AC Input
29	HIN[0]	AC Input
30	SCL	Output Enable
31	SCL	Output
32	SCL	Input
33	SDA	Output Enable
34	SDA	Output
35	SDA	Input
36	RESETN	Input
37	GPIO[0]	Output Enable
38	GPIO[0]	Output
39	GPIO[0]	Input
40	GPIO[1]	Output Enable
41	GPIO[1]	Output
42	GPIO[1]	Input
43	GPIO[2]	Output Enable
44	GPIO[2]	Output
45	GPIO[2]	Input
46	GPIO[3]	Output Enable

Table 37: Boundary Scan Chain Order (Continued)

Order	Ball	Type
47	GPIO[3]	Output
48	GPIO[3]	Input
49	LOP[3]	AC Output
50	LON[3]	AC Output
51	LIP[3]	AC Input
52	LIN[3]	AC Input
53	LOP[2]	AC Output
54	LON[2]	AC Output
55	LIP[2]	AC Input
56	LIN[2]	AC Input
57	LOP[1]	AC Output
58	LON[1]	AC Output
59	LIP[1]	AC Input
60	LIN[1]	AC Input
61	LOP[0]	AC Output
62	LON[0]	AC Output
63	LIP[0]	AC Input
64	LIN[0]	AC Input

3.8.3 EXTEST Instruction

The EXTEST instruction enables circuitry external to the 88X5113 device (typically the board interconnections) to be tested. Prior to executing the EXTEST instruction, the first test stimulus to be applied is shifted into the boundary-scan registers using the sample/preload instruction. So, when the change to the extest instruction occurs, known data is driven immediately from the 88X5113 to its external connections. The SERDES output pins will be driven to static levels. The positive and negative legs of the SERDES output pins are controlled via a single boundary scan cell. The positive leg outputs the level specified by the boundary scan cell while the negative leg outputs the opposite level.

3.8.4 CLAMP Instruction

The CLAMP instruction enables the state of the signals driven from component pins to be determined from the boundary-scan register while the bypass register is selected as the serial path between TDI and TDO. The signals driven from the component pins do not change while the clamp instruction is selected.

3.8.5 HIGH-Z Instruction

The HIGH-Z instruction places all of the digital component system logic outputs in an inactive high-impedance drive state. In this state, an in-circuit test system may drive signals onto the connections normally driven by a component output without incurring the risk of damage to the component.



Note

The SERDES outputs cannot be tri-stated.

3.8.6 ID CODE Instruction

The ID CODE contains the manufacturer identity, part and version.

Table 38: ID CODE Instruction

Version	Part Number	Manufacturer Identity	
Bit 31 to 28	Bit 27 to 12	Bit 11 to 1	Bit 0
0000	0000000001000110	00111101001	1

3.8.7 EXTEST_PULSE Instruction

When the AC/DC select is set to DC the EXTEST_PULSE instruction has the same behavior as the EXTEST instruction.

When the AC/DC select is set to AC, the EXTEST_PULSE instruction has the same behavior as the EXTEST instruction except for the behavior of the SERDES output pins.

As in the EXTEST instruction, the test stimulus must first be shifted into the boundary-scan registers. Upon the execution of the EXTEST_PULSE instruction the SERDES positive output pins output the level specified by the test stimulus and SERDES negative output pins output the opposite level.

However, if the TAP controller enters into the Run-Test/Idle state the SERDES positive output pins output the inverted level specified by the test stimulus and SERDES negative output pins output the opposite level.

When the TAP controller exits the Run-Test/Idle state, the SERDES positive output pins again output the level specified by the test stimulus and SERDES negative output pins output the opposite level.

3.8.8 EXTEST_TRAIN Instruction

When the AC/DC select is set to DC, the EXTEST_TRAIN instruction has the same behavior as the EXTEST instruction.

When the AC/DC select is set to AC, the EXTEST_TRAIN instruction has the same behavior as the EXTEST instruction except for the behavior of the SERDES output pins.

As in the EXTEST instruction, the test stimulus must first be shifted into the boundary-scan registers. Upon the execution of the EXTEST_PULSE instruction the SERDES positive output pins output the level specified by the test stimulus and SERDES negative output pins output the opposite level.

However, if the TAP controller enters into the Run-Test/Idle state the SERDES output pins will toggle between inverted and non-inverted levels on the falling edge of TCK. This toggling will continue for as long as the TAP controller remains in the Run-Test/Idle state.

When the TAP controller exits the Run-Test/Idle state, the SERDES positive output pins again output the level specified by the test stimulus and SERDES negative output pins output the opposite level.
Reference Clock

An external oscillator provides a reference for the on-board transmit Phase Lock Loop (PLL) and clock generation block that provides internal clocks for both the transmit and receive data paths. A 156.25 MHz differential clock should be connected to the CLKP/CLKN pins. AC coupling is required for the pins. The detail requirements for CLKP/CLKN inputs are listed in [Section 7.7](#).

The device can generate a 25 MHz differential output clock on the CLK25P/CLK25N pins that is frequency locked to the 156.25 MHz clock on the CLKP/CLKN pins. If AVDDT is connected to 2.5V or 3.3V supply, then the CLK25P/CLK25N will start oscillating when CLKP/CLKN oscillates at start up. The 25 MHz clock can be disabled by coupling AVDDT to VSS. Additional details on the 25 MHz clock can be found in [Section 6.1](#).

3.9 Temperature Sensor

The device contains an internal temperature sensor.

3.10 On-chip Processor

The chip has a small, efficient microcontroller with supporting hardware designed to offload the system's CPU by automating configuration and workaround tasks.

The processor block can access any register with a PHY and Dev address. It monitors the status of the chip, such as PCS mode, temperature reading, link status, and when it detects an irregularity, it initiates software routines to reconfigure or recover the chip. It supports the boot code loading function through the dedicated TWSI interface from external EEPROM to the internal RAM. There is also a provision to program the external EEPROM from the internal RAM through the common TWSI interface.

3.11 Synchronous Ethernet Mode

The device can output a divide-down version of recovered clock for other chips to synchronize to it. It has two applications as shown in following figures.

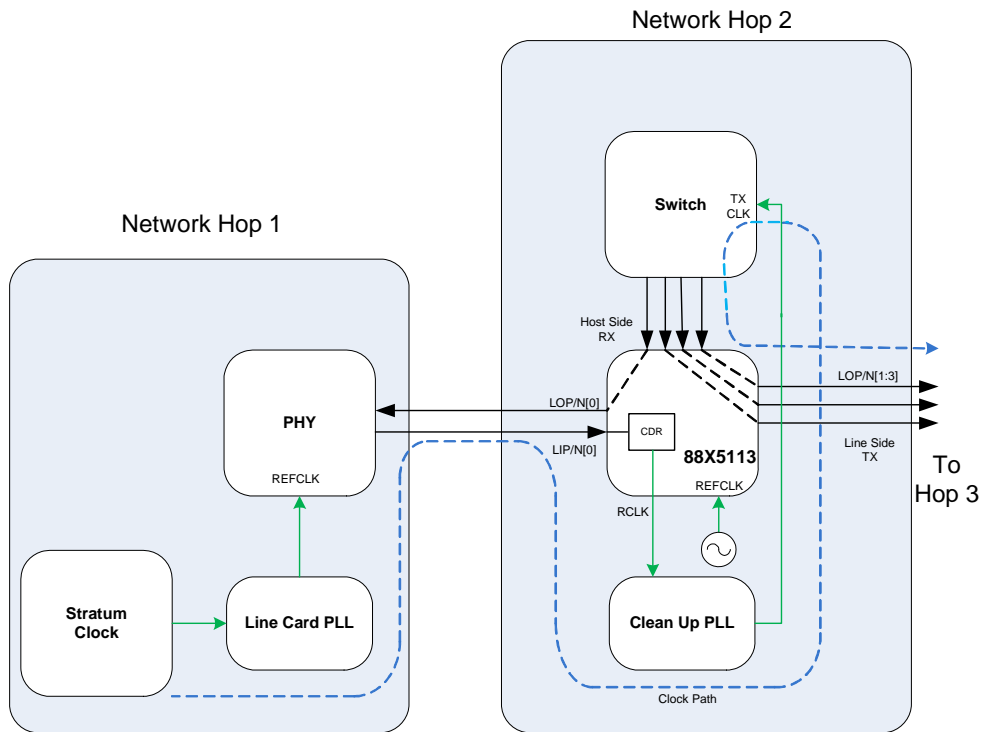
Figure 20: Synchronous Ethernet with 88X5113 in a Non-Ethernet Application such as CPRI

Note: Only relevant signals paths shown in figure for clarity

Figure 21: Synchronous Ethernet with 88X5113 in an Ethernet Application

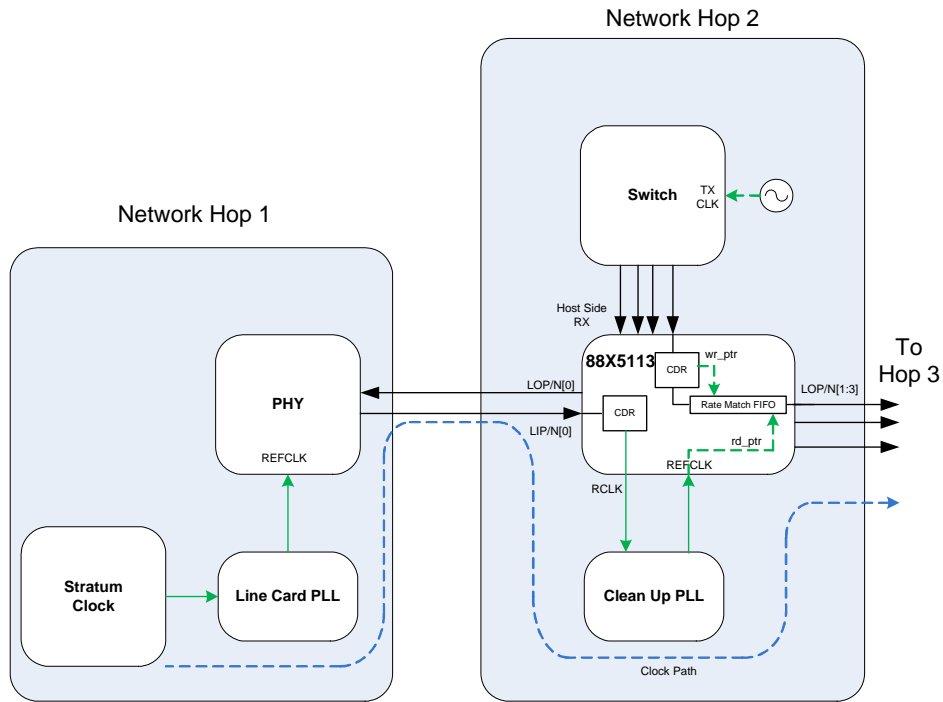

Note: Only relevant signal paths shown in figure for clarity

The recovered clock can be chosen from line side or host side, and from lane 0 to lane 3. The device has three methods to send out recovered clock (called RCLK A,B,C). RCLK A is sent to Interrupt pin (INTn). The RCLK B is sent to SCL pin. RCLK C is sent to SDA pin.

Figure 22 shows the registers to configure final recovered clock RCLK A to INTn pin. Register 31.F422 is controlling Line side clock divider 1. Bit 0 will choose 32T clock when set to 1 and choose 40T clock when set to 0. Bit 2:1 will choose clock from lane 0~3. Bit 4 is set to 1 to enable the clock divider 1. Bit 5 will set whether to enable clock divider after SERDES clock is ready (set 1). Bit 15:8 configures the divider ratio for clock divider 1. The divide ratio is 2 to the power of ([15:8] + 1).

Figure 22: Multiplexing Scheme for Recovered Clock RCLKA

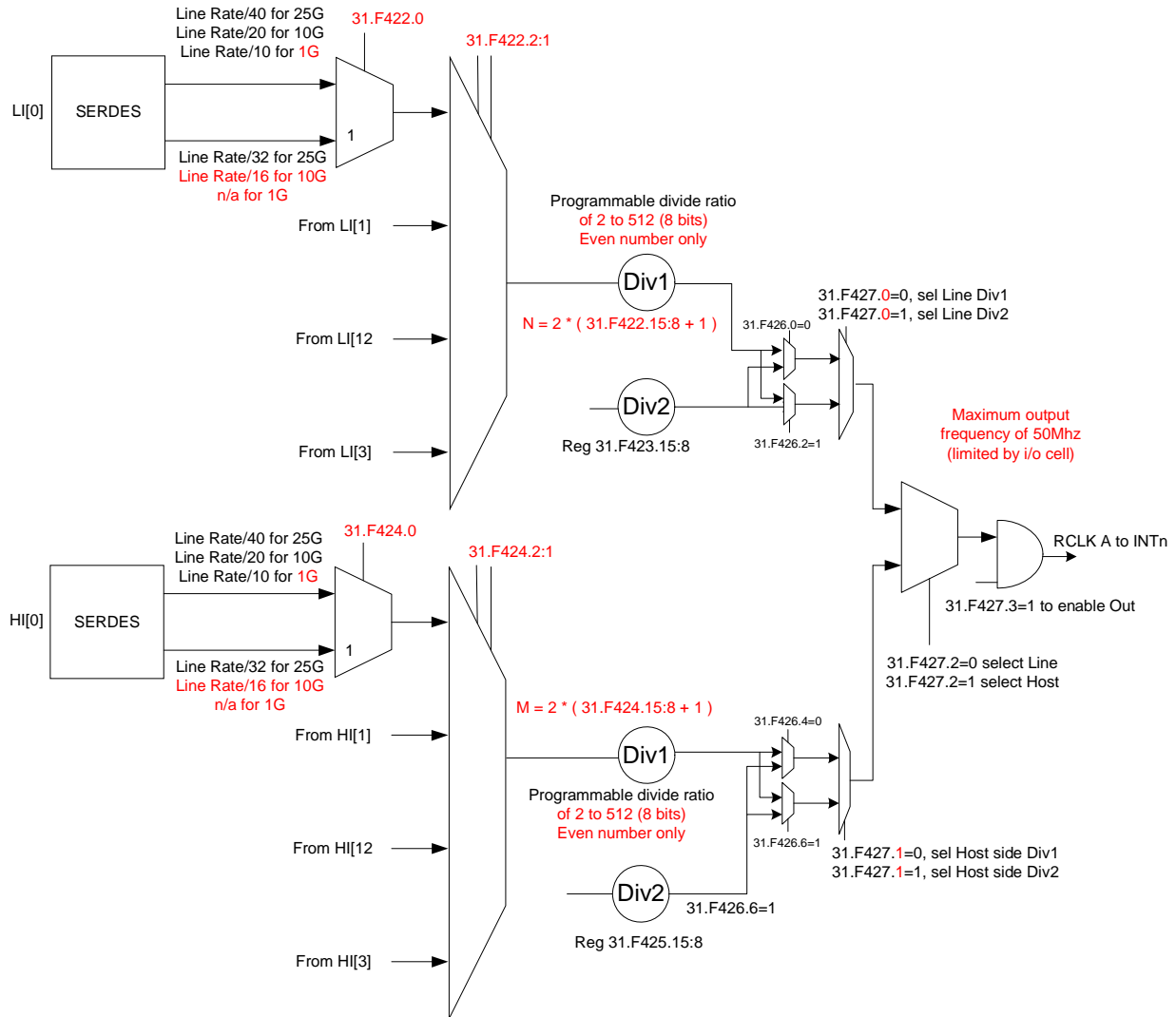

Register 31.F424 controls the host-side clock divider 1. It has same definition as 31.F422.

Register 31.F423 and 31.F425 control Recovered Clock divider 2 of Line Side and Host side correspondingly.

The Line divider 1 clock and divider 2 clock go through MUX 1 and MUX2 to output two clocks (clock1 and clock2) for top-level. It is controlled by 31.F426.0 and 31.F426.2.

The Host divider 1 clock and divider 2 clock go through MUX1 and MUX2 to output two clocks (clock1 and clock2) for top-level. It is controlled by 31.F426.4 and 31.F426.6.

Line clock1, clock2 and Host clock1, clock2 will go through top-level two-level multiplexes to generate final RCLK A, B or C. Each of them can be chosen from either Line or Host side, either from clock1 or clock2 individually.

As shown in [Figure 22](#), 31.F427.3:0 configures the final 4 to 1 selection for RCLK A (to INTn pin). Bit 0 selects Line clock1 or clock2. Bit 1 selects Host clock1 or clock2. Bit 3 choose the clock from Line or Host. Bit 4 is the final clock enable. The controls for RCLK B (to SCL) is 31.F427.7:4. The controls for RCLK C (to SDA) is 31.F427.11:8.

3.12 Power Supplies

The device requires the following supplies to power the core and I/O.

- AVDDL, AVDDH, and AVDDC should be tied together and sourced from the same power supply on the board.
- AVDDL: Line SERDES 1.0V supply
- AVDDH: Host SERDES 1.0V supply
- AVDDC: Common analog 1.0V supply
- AVDDT: For 25 MHz PLL and temperature sensor function. 3.3V or 2.5V is required for operation.
- Couple AVDDT to VSS if the 25 MHz PLL and the temperature sensor functions are not needed. This pin can be tied together with VDDON or VDDOS with filtering to separate it from the digital supply.
- Core 0.9V(Commercial) digital supply
- VDDON: Digital I/O supply. For 2.5V or 3.3V operation, the VSEL_N pin should be tied to VSS. For 1.05V, 1.2V, 1.5V, 1.8V operation, the VSEL_N pin should be tied to VDDON. The pins running on the VDDON supply are RESETn, SCL, SDA, TDI, TDO, TCK, TMS, TRSTn, GPIO[3:0].
- VDDOS: Digital I/O supply. For 2.5V or 3.3V operation, the VSEL_S pin should be tied to VSS. For 1.05V, 1.2V, 1.5V, and 1.8V operation, the VSEL_S pin should be tied to VDDOS. The pins running on the VDDOS supply are MDC, MDIO, INTn, PHYAD[3:0], CONFIG[2:0], TEST[1:0].

4 Line Side Description

The line interface comprises four differential input lanes and four differential output lanes. [Table 40](#) lists out what is active for all the modes. The device can be configured to operate in single-port operation or four sub-port operation depending on how many SERDES lanes are used to form the port. Each sub-port's mode of operation can be configured via Auto-Negotiation or forced mode. Any of the modes shown in [Table 40](#) can be set via forced mode. However, only the modes with the Y in the last column can be configured via Clause 73 Auto-Negotiation. [Table 41](#) shows the register setting required to force a particular mode. Register 3.F00n is used to select the sub-port n. 40 Gbps, 50 Gbps, and 100 Gbps speeds are not supported by sub-ports 1, 2, and 3.

For the purpose of the subsequent discussion, we will refer only to the registers in sub-port 0 unless otherwise noted. The registers in ports 1, 2, and 3 are offset as shown in the Equivalent Registers Between Line and Host Interface table in [Section 5](#) and behave in the same way as sub-port 0. Single-port operation (multi-lane port operation) maps into sub-port 0. That is, sub-port 0 supports all speeds, while sub-port 1, 2, and 3 supports neither 40 Gbps, 50 Gbps, nor 100 Gbps speeds.

The priority for mode selection is listed in decreasing order of priority:

1. If Auto-Negotiation of sub-port 0 is enabled (7.0000.12 = 1) and any capability that requires multiple lanes is advertised (for example, 40 Gbps, 50 Gbps, or 100 Gbps), then operation on sub-ports 1, 2, and 3 are disabled. Registers 3.F000 to 3.F0003 are ignored. Auto-Negotiation will determine the mode to operate. Even if the Auto-Negotiation result in a single-lane operation, sub-ports 1, 2, and 3 will still be disabled.
2. If Auto-Negotiation of sub-port 0 is disabled (7.0000.12 = 0), then register 3.F000 is used to force the mode of operation on sub-port 0. If a capability that requires multiple lanes is selected, then operation on sub-ports 1, 2, and 3 are disabled and registers 3.F001 to 3.F003 are ignored.
3. If neither #1 nor #2 above are in effect, then each sub-port operates independently. If sub-port n Auto-Negotiation is enabled then Auto-Negotiation will determine the mode to operate and register 3.F00n is ignored.
4. If none of the above are in effect, then register 3.F00n will determine the mode of operation.

If Auto-Negotiation is disabled on sub-port n and register 3.F00n selects a mode that requires Clause 72 training, then it is the user's responsibility to properly set the Auto-Negotiation registers to advertise only the capability that is consistent with the mode requested in register 3.F00n even though register 7.0000.12 is set to 0. The Auto-Negotiation in this case is used only to synchronize the two link partners in order to start the Clause 72 training. As part of the Clause 72 training procedure, the device will automatically initiate Auto-Negotiation even though register 7.0000.12 is set to 0. When Auto-Negotiation completes the device will commence Clause 72 training for the mode selected in register 3.F00n. The device only checks that Auto-Negotiation completes, and does not check whether the resolved capability matches the mode selected in register 3.F00n.

4.1 Interface Modes of Operation

Table 39 provides a description of the interface modes of operations detailed in Table 40.

Table 39: Mode Definition Reference

Symbol	Description
Type	P = PCS R = Retimer
Speed	1 = 1 Gbps - single lane 2.5 = 2.5 Gbps - single lane 5 = 5 Gbps - single lane 10 = 10 Gbps - single lane 25 = 25 Gbps - 1 lane x 25 Gbps or 2 lanes x 12.5 Gbps or 4 lanes x 6.25G 40 = 40 Gbps - 4 lanes x 10 Gbps 50 = 50 Gbps - 1 lane x 50 Gbps or 2 lanes x 25 Gbps or 4 lanes x 12.5 Gbps 100 = 100 Gbps - 2 lanes x 50 Gbps or 4 lanes x 25 Gbps 200 = 200 Gbps - 4 lanes x 50 Gbps
Training/AN/Co ding	X = BASE-X S = SGMII System P = SGMII PHY L = NRZ BASE-R/X, no Auto-Negotiation K = NRZ BASE-R/X, Backplane C = NRZ BASE-R, Twinax J = Same as K except consortium B = Same as C except consortium M = same as L Non-Standard 50GBASE-R2 U = PAM4 BASE-R, no Auto-Negotiation Q = PAM4 BASE-R, Twin ax/Backplane Y = Same as L for Non-Standard 25GBASE-R2, no Auto-Negotiation Z = Same as C for Non-Standard 25GBASE-R2, Auto-Negotiation A = Same as L for Non-Standard 25GBASE-R4, no Auto-Negotiation G = Same as C for Non-Standard 25GBASE-R4, Auto-Negotiation H = Same as K for Non-Standard 25GBASE-R4, Auto-Negotiation
FEC	N = No FEC F = KR-FEC (Firecode) R = RS-FEC (528, 514) P = RS-FEC (544, 514)

Table 40: Interface Modes of Operation

Mode	Description	PCS	FEC	PMA	Autoneg	Training	Line I/O	Multi-speed AP Autoneg Resolution
P1X	1000BASE-X	1000BASE-X (CL 36)	None	Clause 36	Clause 37/73	None	N/A	Y
P1S	SGMII (System)	1000BASE-X (SGMII)	None	Clause 36	SGMII	None	N/A	
P1P	SGMII (PHY)	1000BASE-X (SGMII)	None	Clause 36	SGMII	None	N/A	
P2.5X	2.5GBASE-X	2.5GBASE-X (* CL 36)	None	Clause 36 ¹	Clause 73 ²	None	CU4HDD ¹	Y
P5L	5GBASE-R	5GBASE-R (* CL 49)	None	Clause 51 ¹	Clause 73 ²	None	CU4HDD ¹	Y
P10LN	10GBASE-LR/SR	10GBASE-R (CL 49)	None	Clause 51	None	None	SFI/SFP+	
P10KN	10GBASE-KR (No FEC)	10GBASE-R (CL 49)	None	Clause 51	Clause 73	CL 72.6.10	KR (CL 72)	Y
P10KF	10GBASE-KR (FEC)	10GBASE-R (CL 49)	KR (CL 74)	Clause 51	Clause 73	CL 72.6.10	KR (CL 72)	Y
P10LF	10G (Non-standard)	10GBASE-R (CL 49)	KR (CL 74)	Clause 51	None	None	SFI/SFP+	
P25LN	25G (Non-standard) (No FEC)	25GBASE-R (CL 107)	None	Clause 109	None	None	25GAUI (109A, 109B)	
P25LF	25G (Non-standard) (KR-FEC)	25GBASE-R (CL 107)	KR (CL 74)	Clause 109	None	None	25GAUI (109A, 109B)	
P25LR	25GBASE-SR	25GBASE-R (CL 107)	RS (CL 108)	Clause 109	None	None	25GAUI (109A, 109B)	
P25CN	25GBASE-CR (No FEC)	25GBASE-R (CL 107)	None	Clause 109	Clause 73	CL 72.6.10	CR (CL 110)	Y
P25CF	25GBASE-CR (KR-FEC)	25GBASE-R (CL 107)	KR (CL 74)	Clause 109	Clause 73	CL 72.6.10	CR (CL 110)	Y
P25CR	25GBASE-CR (RS-FEC)	25GBASE-R (CL 107)	RS (CL 108)	Clause 109	Clause 73	CL 72.6.10	CR (CL 110)	Y
P25KN	25GBASE-KR (No FEC)	25GBASE-R (CL 107)	None	Clause 109	Clause 73	CL 72.6.10	KR (CL 111)	Y
P25KF	25GBASE-KR (KR-FEC)	25GBASE-R (CL 107)	KR (CL 74)	Clause 109	Clause 73	CL 72.6.10	KR (CL 111)	Y
P25KR	25GBASE-KR (RS-FEC)	25GBASE-R (CL 107)	RS (CL 108)	Clause 109	Clause 73	CL 72.6.10	KR (CL 111)	Y
P25BN	25GBASE-CR (No FEC) (Consortium)	25GBASE-R (CL 107)	None	Clause 109	Con OUI	CL 72.6.10	CR (CL 110)	Y
P25BF	25GBASE-CR (KR-FEC) (Consortium)	25GBASE-R (CL 107)	KR (CL 74)	Clause 109	Con OUI	CL 72.6.10	CR (CL 110)	Y
P25BR	25GBASE-CR (RS-FEC) (Consortium)	25GBASE-R (CL 107)	RS (CL 108)	Clause 109	Con OUI	CL 72.6.10	CR (CL 110)	Y

Table 40: Interface Modes of Operation (Continued)

Mode	Description	PCS	FEC	PMA	Autoneg	Training	Line I/O	Multi-speed AP Autoneg Resolution
P25JN	25GBASE-KR (No FEC) (Consortium)	25GBASE-R (CL 107)	None	Clause 109	Con OUI	CL 72.6.10	KR (CL 111)	Y
P25JF	25GBASE-KR (KR-FEC) (Consortium)	25GBASE-R (CL 107)	KR (CL 74)	Clause 109	Con OUI	CL 72.6.10	KR (CL 111)	Y
P25JR	25GBASE-KR (RS-FEC) (Consortium)	25GBASE-R (CL 107)	RS (CL 108)	Clause 109	Con OUI	CL 72.6.10	KR (CL 111)	Y
P40LN	40GBASE-LR4/SR4	40GBASE-R4 (CL 82)	None	Clause 83	None	None	XLAUI (CL 83A, 83B)	
P40CN	40GBASE-CR4 (No FEC)	40GBASE-R4 (CL 82)	None	Clause 83	Clause 73	CL 72.6.10	CR4 (CL 85)	Y
P40CF	40GBASE-CR4 (FEC)	40GBASE-R4 (CL 82)	KR (CL 74)	Clause 83	Clause 73	CL 72.6.10	CR4 (CL 85)	Y
P40KN	40GBASE-KR4 (No FEC)	40GBASE-R4 (CL 82)	None	Clause 83	Clause 73	CL 72.6.10	KR4 (CL 84)	Y
P40KF	40GBASE-KR4 (FEC)	40GBASE-R4 (CL 82)	KR (CL 74)	Clause 83	Clause 73	CL 72.6.10	KR4 (CL 84)	Y
P40LF	40G (Non-standard)	40GBASE-R4 (CL 82)	KR (CL 74)	Clause 83	None	None	XLAUI (CL 83A, 83B)	
P50LN	50GBASE-LR4/SR4	50GBASE-R4 (CL 82)	None	Clause 83	None	None	XLAUI (CL 83A, 83B)	
P50CN	50GBASE-CR4 (No FEC)	50GBASE-R4 (CL 82)	None	Clause 83	Clause 73 ⁴	CL 72.6.10	CR4 (CL 85)	
P50CF	50GBASE-CR4 (FEC)	50GBASE-R4 (CL 82)	KR (CL 74)	Clause 83	Clause 73 ⁴	CL 72.6.10	CR4 (CL 85)	
P50KN	50GBASE-KR4 (No FEC)	50GBASE-R4 (CL 82)	None	Clause 83	Clause 73 ⁴	CL 72.6.10	KR4 (CL 84)	
P50KF	50GBASE-KR4 (FEC)	50GBASE-R4 (CL 82)	KR (CL 74)	Clause 83	Clause 73 ⁴	CL 72.6.10	KR4 (CL 84)	
P50LF	50G (Non-standard)	50GBASE-R4 (CL 82)	KR (CL 74)	Clause 83	None	None	XLAUI (CL 83A, 83B)	
P50MN	50G (Non-standard) (No FEC)	50GBASE-R2 (CL 82)	None	4:2 (CL 83)	None	None	2 lane (CL 83A, 83B)	
P50MF	50G (Non-standard) (KR-FEC)	50GBASE-R2 (CL 82)	KR (CL 74)	4:2 (CL 83)	None	None	2 lane (CL 83A, 83B)	
P50MR	50G (Non-standard) (RS-FEC)	50GBASE-R2 (CL 82)	RS (Con)	4:2 (CL 83)	None	None	2 lane (CL 83A, 83B)	
P50BN	50GBASE-CR2 (No FEC) (Consortium)	50GBASE-R2 (CL 82)	None	4:2 (CL 83)	Con OUI	CL 72.6.10	2 lane CR (CL 85)	Y
P50BF	50GBASE-CR2 (KR-FEC) (Consortium)	50GBASE-R2 (CL 82)	KR (CL 74)	4:2 (CL 83)	Con OUI	CL 72.6.10	2 lane CR (CL 85)	Y

Table 40: Interface Modes of Operation (Continued)

Mode	Description	PCS	FEC	PMA	Autoneg	Training	Line I/O	Multi-speed AP Autoneg Resolution
P50BR	50GBASE-CR2 (RS-FEC) (Consortium)	50GBASE-R2 (CL 82)	RS (Con)	4:2 (CL 83)	Con OUI	CL 72.6.10	2 lane CR (CL 85)	Y
P50JN	50GBASE-KR2 (No FEC) (Consortium)	50GBASE-R2 (CL 82)	None	4:2 (CL 83)	Con OUI	CL 72.6.10	2 lane KR (CL 84)	Y
P50JF	50GBASE-KR2 (KR-FEC) (Consortium)	50GBASE-R2 (CL 82)	KR (CL 74)	4:2 (CL 83)	Con OUI	CL 72.6.10	2 lane KR (CL 84)	Y
P50JR	50GBASE-KR2 (RS-FEC) (Consortium)	50GBASE-R2 (CL 82)	RS (Con)	4:2 (CL 83)	Con OUI	CL 72.6.10	2 lane KR (CL 84)	Y
P100LN	100GBASE-LR4	100GBASE-R4 (CL 82)	None	Clause 83	None	None	CAUI-4 (CL 83D, 83E)	
P100LR	100GBASE-SR4	100GBASE-R4 (CL 82)	RS (CL 91)	Clause 83	None	None	CAUI-4 (CL 83D, 83E)	
P100CR	100GBASE-CR4	100GBASE-R4 (CL 82)	RS (CL 91)	Clause 83	Clause 73	CL 72.6.10	CR4 (CL 92)	Y
P100KR	100GBASE-KR4	100GBASE-R4 (CL 82)	RS (CL 91)	Clause 83	Clause 73	CL 72.6.10	KR4 (CL 92)	Y
P100KN	100G (Non-standard)	100GBASE-R4 (CL 82)	None	Clause 83	Clause 73 ³	CL 72.6.10	KR4 (CL 92)	
R1	1G - Transparent	1G - Retimer	None	None	None	None	N/A	
R2.5	2.5G - Transparent	2.5G - Retimer	None	None	Clause 73 ²	None	CU4HDD ¹	
R5	5G - Transparent, (No Training)	5G - Retimer	None	None	Clause 73 ²	None	CU4HDD ¹	
R10L	10G - Transparent, (No Training)	10G - Retimer	None	None	None	None	SFI/SFP+	
R10K	10G - Transparent, (KR Training)	10G - Retimer	None	None	Clause 73	CL 72.6.10	KR (CL 72)	
R25L	25G - Transparent, (No Training)	25G - Retimer	None	None	None	None	25GAUI (109A, 109B)	
R25C	25G - Transparent, (CR Training)	25G - Retimer	None	None	Clause 73	CL 72.6.10	CR4 (CL 110)	
R25K	25G - Transparent, (KR Training)	25G - Retimer	None	None	Clause 73	CL 72.6.10	KR4 (CL 111)	
R40L	40G - Transparent, (No Training)	40G - Retimer	None	None	None	None	XLAUI (CL 83A, 83B)	
R40C	40G - Transparent, (CR Training)	40G - Retimer	None	None	Clause 73	CL 72.6.10	CR4 (CL 85)	
R40K	40G - Transparent, (KR Training)	40G - Retimer	None	None	Clause 73	CL 72.6.10	KR4 (CL 84)	
R100L	100G - Transparent, (No Training)	100G - Retimer	None	None	None	None	CAUI-4 (CL 83D, 83E)	
R100C	100G - Transparent, (CR Training)	100G - Retimer	None	None	Clause 73	CL 72.6.10	CR4 (CL 92)	
R100K	100G - Transparent, (KR Training)	100G - Retimer	None	None	Clause 73	CL 72.6.10	KR4 (CL 92)	



Note

- 2.5G and 5G mode currently being defined in IEEE 802.3 CU4HDD study group.
- Clause 73 Auto-Negotiation can be turned on or off. Bits being defined by CU4HDD.
- The P100KN mode is non-standard but requires Auto-Negotiation to be on to start training. The 100GBASE-CR4 bit will be used.
- 50GBASE-R4 uses 40GBASE-R4 Auto-Negotiation ability bits to negotiate. This is a custom mode where both link partners know a-priori to negotiate to 50G
- R400Q uses AN based on Clause 73, with use of allocated next page field for CR-8 and Clause 136 start up protocol for pre-coder/training options.

Table 41: Register Control to Select Mode of Operation

TBD	Reimport	3.F00n.2:0 ¹	3.F00n.4	3.F00n.5	3.F00n.7:6	3.F00n.9:8
P1X	1000BASE-X	000	0	1	00	00
P1S	SGMII (System)	000	0	1	00	11
P1P	SGMII (PHY)	000	0	1	00	10
P2.5X	2.5GBASE-X	001	0	1	00	XX ²
P5L	5GBASE-R	010	0 or 1	1	00	XX
P10LN	10GBASE-LR/SR	011	0	1	00	XX
P10KN	10GBASE-KR (No FEC)	011	1	1	00	XX
P10KF	10GBASE-KR (FEC)	011	1	1	01	XX
P10LF	10G (Non-standard)	011	0	1	01	XX
P25LN	25G (Non-standard) (No FEC)	100	0	1	00	XX
P25LF	25G (Non-standard) (KR-FEC)	100	0	1	01	XX
P25LR	25GBASE-SR	100	0	1	10	XX
P25CN	25GBASE-CR (No FEC)	100	1	1	00	00
P25CF	25GBASE-CR (KR-FEC)	100	1	1	01	00
P25CR	25GBASE-CR (RS-FEC)	100	1	1	10	00
P25KN	25GBASE-KR (No FEC)	100	1	1	00	01
P25KF	25GBASE-KR (KR-FEC)	100	1	1	01	01

Table 41: Register Control to Select Mode of Operation (Continued)

TBD	Reimport	3.F00n.2:0 ¹	3.F00n.4	3.F00n.5	3.F00n.7:6	3.F00n.9:8
P25KR	25GBASE-KR (RS-FEC)	100	1	1	10	01
P25BN	25GBASE-CR (No FEC) (Consortium)	100	1	1	00	10
P25BF	25GBASE-CR (KR-FEC) (Consortium)	100	1	1	01	10
P25BR	25GBASE-CR (RS-FEC) (Consortium)	100	1	1	10	10
P25JN	25GBASE-KR (No FEC) (Consortium)	100	1	1	00	11
P25JF	25GBASE-KR (KR-FEC) (Consortium)	100	1	1	01	11
P25JR	25GBASE-KR (RS-FEC) (Consortium)	100	1	1	10	11
P40LN	40GBASE-LR4/SR4	101	0	1	00	0X
P40CN	40GBASE-CR4 (No FEC)	101	1	1	00	00
P40CF	40GBASE-CR4 (FEC)	101	1	1	01	00
P40KN	40GBASE-KR4 (No FEC)	101	1	1	00	01
P40KF	40GBASE-KR4 (FEC)	101	1	1	01	01
P40LF	40G (Non-standard)	101	0	1	01	0X
P50LN	50GBASE-LR4/SR4	110	0	1	00	0X
P50CN	50GBASE-CR4 (No FEC)	110	1	1	00	00
P50CF	50GBASE-CR4 (FEC)	110	1	1	01	00
P50KN	50GBASE-KR4 (No FEC)	110	1	1	00	01
P50KF	50GBASE-KR4 (FEC)	110	1	1	01	01
P50LF	50G (Non-standard)	110	0	1	01	0X
P50MN	50G (Non-standard) (No FEC)	110	0	1	00	1X
P50MF	50G (Non-standard) KR-FEC	110	0	1	01	1X

Table 41: Register Control to Select Mode of Operation (Continued)

TBD	Reimport	3.F00n.2:0 ¹	3.F00n.4	3.F00n.5	3.F00n.7:6	3.F00n.9:8
P50MR	50G (Non-standard) (RS-FEC)	110	0	1	10	1X
P50BN	50GBASE-CR2 (No FEC) (Consortium)	110	1	1	00	10
P50BF	50GBASE-CR2 (KR-FEC) (Consortium)	110	1	1	01	10
P50BR	50GBASE-CR2 (RS-FEC) (Consortium)	110	1	1	10	10
P50JN	50GBASE-KR2 (No FEC) (Consortium)	110	1	1	00	11
P50JF	50GBASE-KR2 (KR-FEC) (Consortium)	110	1	1	01	11
P50JR	50GBASE-KR2 (RS-FEC) (Consortium)	110	1	1	10	11
P100LN	100GBASE-LR4	111	0	1	00	XX
P100LR	100GBASE-SR4	111	0	1	10	XX
P100CR	100GBASE-CR4	111	1	1	10	00
P100KR	100GBASE-KR4	111	1	1	10	01
P100KN	100G (Non-standard)	111	1	1	00	00

1. 3.F00n where n is sub-port n.
2. Where X means don't care.

Table 42: Base Link Register on PCS Modes

88X5113	Base Link Register (3.x for Line Side, 4.x for Host Side)	Modes
1G	3001	P1*
2.5G	3001	P2p5**
5G	2001	P5*
10G	2001	P10**
25GR1	2001	P25B/C/J/K/L*
25GR2	1001	P25Y/Z*
25GR4	1001	P25A/G/H*
40GR2	1001	P40B/J*
40GR4	1001	P40C/K/L*
50GR1	1001	P50U/Q*
50GR2	1001	P50B/J/M*

Table 42: Base Link Register on PCS Modes (Continued)

88X5113	Base Link Register (3.x for Line Side, 4.x for Host Side)	Modes
50GR4	1001	P50C/K/L*
100GR2	1	P100U/Q*
100GR4	1	P100C/K/L*
200GR4	4001	P200**

NOTE: **The dsp lock for lane 0, 1, 2, and 3 are at registers 0xF201.5, 0xF221.5, 0xF241.5, and 0xF261.

4.2 Electrical Interface

The input of the SERDES (Rx) is AC coupled on die while the output (Tx) is not AC coupled. All SERDES inputs and outputs are internally terminated by 50Ω each (or 100Ω differential).

The SERDES transmitter uses a three-tap (1 pre-tap and 1 post-tap) FIR filter is implemented for the purpose of channel equalization. The FIR tap values are automatically adjusted during Clause 72 training or can be manually adjusted to optimize the transmit eye over a particular channel.

[Table 40](#) Line I/O column lists out the supported electrical interfaces. Refer to the appropriate standards for detailed information.

4.3 PCS and PMA

The device supports many different modes of operation as shown in [Table 40](#), all the PCS modes reduce down to four PCS types as shown in [Table 43](#). There are four copies of each single-lane PCS types forming four sub-ports and one copy of each multi-lane PCS on sub-port 0. The register location of each PCS type are summarized in the Equivalent Registers Between Line and Host Interface table in [Section 5](#).

Table 43: PCS Types

PCS Mode	PCS Type	Sub-Port 0	Sub-Port 1	Sub-Port 2	Sub-Port 3
1000BASE-X	1000BASE-X	X	X	X	X
SGMII PHY					
SGMII System					
2.5GBASE-X					
5GBASE-R	10GBASE-R	X	X	X	X
10GBASE-R					
25GBASE-R					
40GBASE-R4	40GBASE-R4	X			
50GBASE-R4					
50GBASE-R2					
100GBASE-R4	100GBASE-R4	X			

4.3.1 100GBASE-R4 PCS (Modes P100*)

The various 100GBASE-R4 PCS and PMA operate according to IEEE 802.3ba, 802.3bj, and 802.3bm specifications depending on the type selected. In general, a 64B/66B coding and scrambling is used to improve the transmission characteristics of the serial data and ease clock recovery at the receiver. The data stream is distributed across 20 virtual lanes. The alignment markers allows the lanes to be aligned and lanes to be reordered at the receiver. The Reed Solomon FEC reduces the bit error rate of the recovered data.

100GBASE-LR4 up to the CAUI-4 interface takes the path from the CGMII through the 20:4 bit multiplexer to the serializer on the egress direction. It takes the path from the de-serializer through the 4:20 de-multiplexer to the CGMII in the ingress direction. The Reed Solomon FEC is not used and there is no training of the transmitter FIR coefficients.

100GBASE-SR4 up to the CAUI-4 interface takes the path from the CGMII through the transcoder through the Reed Solomon encoder through the symbol distribution to the serializer on the egress direction. The alignment marker is remapped and sent to the Reed Solomon encoder. The receive path starts from the de-serializer through the alignment/de-skew/reorder through the Reed Solomon to the CGMII in the ingress direction. There is no training of the transmitter FIR coefficients. The Reed Solomon uses the RS (528, 514) code.

100GBASE-CR4 (to the CR4 PMD) path is identical to 100GBASE-SR4 except IEEE 802.3 Clause 72.6.10 training occurs to set the transmitter FIR coefficients and the receiver equalization is tuned for shielded balanced copper cabling.

100GBASE-KR4 path is identical to 100GBASE-CR4 except the transmitter FIR and the receiver equalization is tuned for KR4 electrical backplanes.

RS (528, 514). In modes where the Reed Solomon FEC is active, the behavior of the FEC can be modified by setting register 1.00C8.1:0.

- 00 = Full error detection and correction, set 1.00C8 = 16'h0000.
- 01 = Error detection without correction. Blocks with errors will be intentionally corrupted to prevent uncorrectable errors from propagating, set 1.00C8 = 16'h0001.
- 10 = Error detection without correction. Blocks with errors will be passed as received.
- The detected error will be reported in registers 1.00CC and 1.00CD.

Each of the bit settings requires a software reset to take effect.

P100KN is a non-standard mode that operates similarly to 100GBASE-LR4 without FEC, but IEEE 802.3 Clause 72.6.10 training occurs. When in this mode, the 100GBASE-CR4 Auto-Negotiation ability is set to initiate the training.

Figure 23: 100GBASE-R4 Data Path

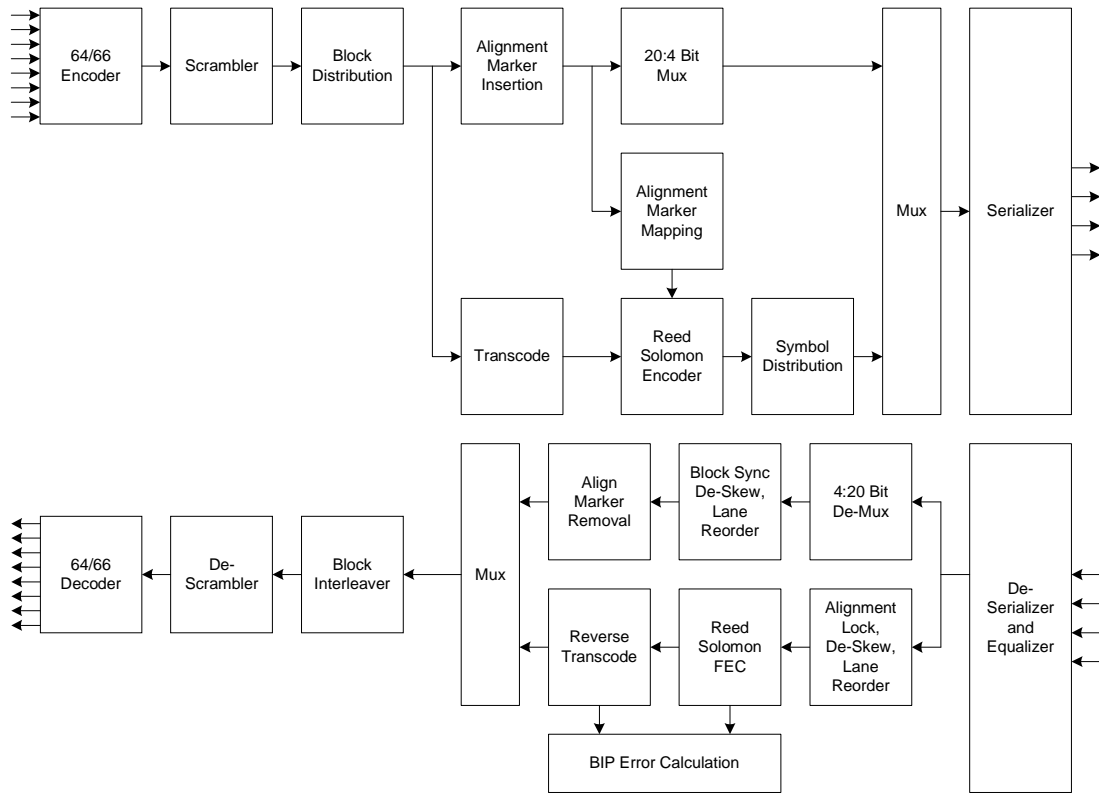

4.3.2 40GBASE-R4, 50GBASE-R4, 50GBASE-R2 PCS (Modes P40*, P50*)

The 40GBASE-R4 PCS operates according to the IEEE 802.3ba specification. The PCS uses a 64B/66B coding and scrambling to improve the transmission characteristics of the serial data and ease clock recovery at the receiver. The data stream is distributed across 4 lanes. The alignment markers allow the lanes to be aligned and lanes to be swapped at the receiver. The synchronization headers for 64B/66B code enable the receiver to achieve block alignment on the receive data.

The 40GBASE-R4 datapath is shown in [Figure 24](#). The Reed-Solomon encoder/FEC path and 4:2 Mux/2:4 De-Mux paths are bypassed in the 40GBASE-R4 and 50GBASE-R4. The differences among the various types are described below.

40GBASE-LR4 up to the XLAUI-4 interface has no training of the transmitter FIR coefficients.

40GBASE-CR4 uses IEEE 802.3 Clause 72.6.10 training to set the transmitter FIR coefficients. The receiver equalization is tuned for shielded balanced copper cabling. The optional Clause 74 KR-FEC can be enabled or disabled.

40GBASE-KR4 path is identical to 40GBASE-CR4 except the transmitter FIR and the receiver equalization is tuned for KR4 electrical backplanes. The optional Clause 74 KR-FEC can be enabled or disabled.

P40LF is a non-standard mode that operates similarly to 40GBASE-LR4 with the KR-FEC enabled. IEEE 802.3 Clause 72.6.10 training does not take place.

P50L*, P50C*, P50K* modes are identical to each corresponding P40* modes except the line rate is 1.25 times faster.

The 50GBASE-R2 datapath is shown in [Figure 24](#). The path either goes through the Reed-Solomon encoder/FEC path or the 4:2 Mux/2:4 De-Mux paths.

50GBASE-CR2 without FEC and with KR-FEC is similar to 40GBASE-CR4 except the data rate is 1.25 times faster and 4 virtual lanes are bit interleaved onto 2 lanes. This mode uses IEEE 802.3 Clause 72.6.10 training to set the transmitter FIR coefficients. The receiver equalization is tuned for shielded balanced copper cabling.

50GBASE-CR2 with RS-FEC is similar to 40GBASE-CR4 except the data rate is 1.25 times faster and 4 virtual lanes are transcoded and put through the Reed-Solomon encoder. The Reed-Solomon symbols are symbol interleaved onto two lanes. This mode uses IEEE 802.3 Clause 72.6.10 training to set the transmitter FIR coefficients. The receiver equalization is tuned for shielded balanced copper cabling.

50GBASE-KR2 path is identical to 50GBASE-CR2 except the transmitter FIR and the receiver equalization is tuned for KR electrical backplanes.

P50M* modes are identical to each corresponding P50B* modes except IEEE 802.3 Clause 72.6.10 training is not used.

Figure 24: 40GBASE-R4, 50GBASE-R4, and 50GBASE-R2 Datapath

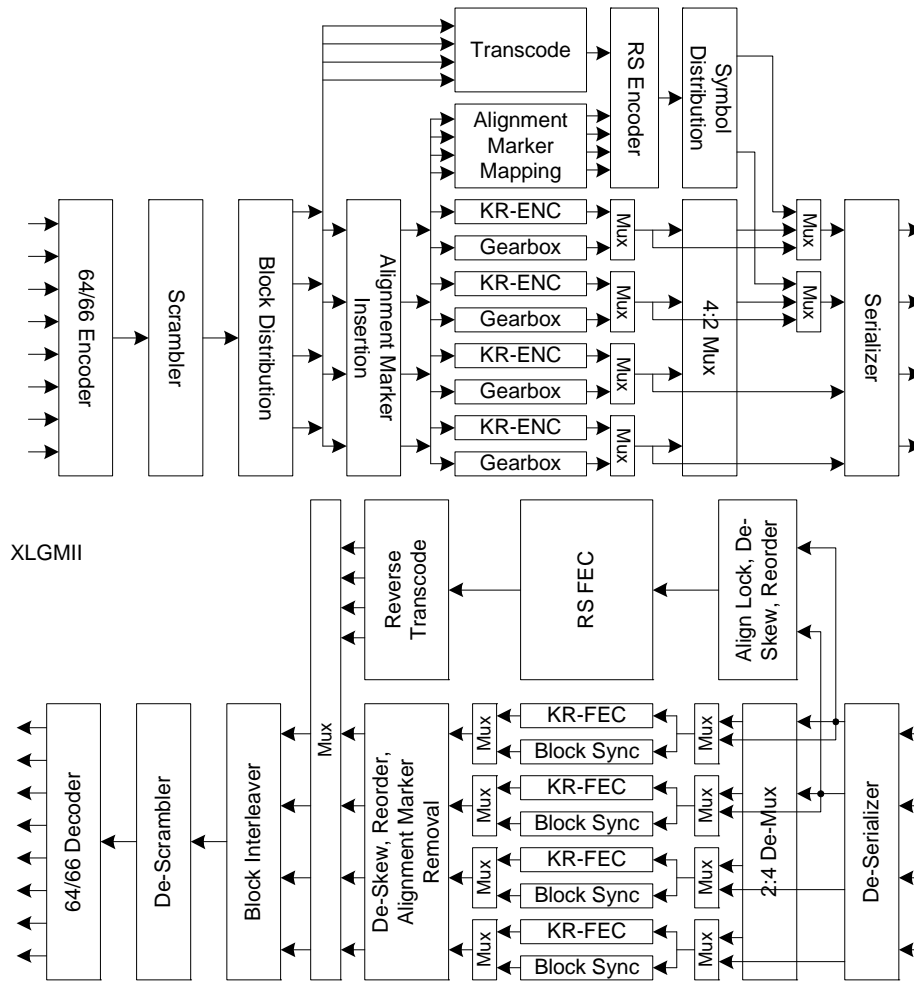

4.3.3 5GBASE-R, 10GBASE-R, and 25GBASE-R PCS (Modes P5L, P10*, P25*)

The 10GBASE-R PCS operates according to the IEEE 802.3 Clause 49 specification. The 25GBASE-R PCS operates according to the IEEE 802.3by specification. The PCS uses a 64B/66B coding and scrambling to improve the transmission characteristics of the serial data and ease clock recovery at the receiver.

The 5GBASE-R, 10GBASE-R, and 25GBASE-R datapath is shown in [Figure 25](#).

10GBASE-SR/LR has no training of the transmitter FIR coefficients.

10GBASE-KR uses IEEE 802.3 Clause 72.6.10 training to set the transmitter FIR coefficients. The receiver equalization is tuned for either shielded balanced copper cabling or KR electrical backplanes. The optional Clause 74 KR-FEC can be enabled or disabled.

P10LF is a non-standard mode that operates similarly to 10GBASE-LR with the KR-FEC enabled. IEEE 802.3 Clause 72.6.10 training does not occur.

5GBASE-R is identical to 10GBASE-SR/LR running at half speed.

25GBASE-SR uses the Clause 108 RS-FEC but has no training of the transmitter FIR coefficients.

25GBASE-CR is similar to 25GBASE-SR except it uses IEEE 802.3 Clause 72.6.10 training to set the transmitter FIR coefficients. The receiver equalization is tuned for shielded balanced copper cabling. The optional Clause 74 KR-FEC can be enabled or disabled. The optional Clause 108 RS-FEC can be enabled or disabled.

25GBASE-KR path is identical to 25GBASE-CR except the transmitter FIR and the receiver equalization is tuned for KR electrical backplanes. The optional Clause 74 KR-FEC can be enabled or disabled. The optional Clause 108 RS-FEC can be enabled or disabled.

P25B* modes are identical to each corresponding P25C* modes except the Auto-Negotiation used is per the Consortium specification.

P25J* modes are identical to each corresponding P25K* modes except the Auto-Negotiation used is per the Consortium specification.

P25LN is identical to 10GBASE-SR/LR except running 2.5 times faster.

P25LF is identical to P10LF except running 2.5 times faster.

Figure 25: 5GBASE-R, 10GBASE-R, and 25GBASE-R Datapath

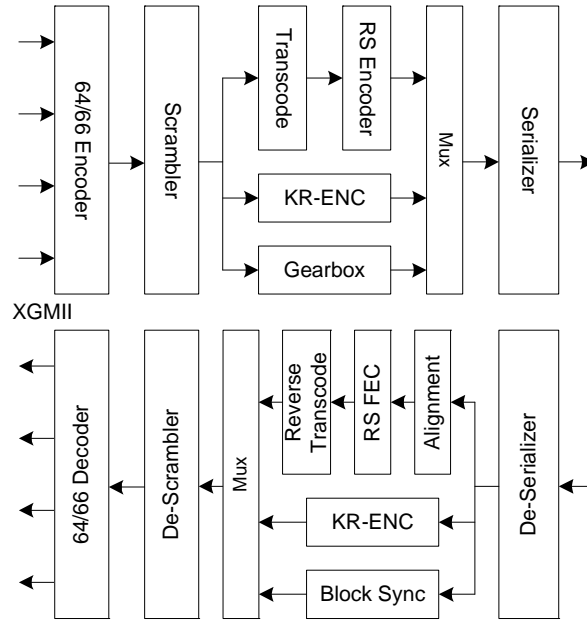

4.3.4 SGMII, 1000BASE-X, and 2.5GBASE-X

4.3.4.1 PCS

The 1000BASE-X PCS operates according to Clause 36 of the IEEE 802.3 specification. The PCS uses a 8/10 bit coding for DC line balancing. For further details, refer to the IEEE 802.3 specification.

The SGMII protocol is also supported over 1000BASE-X. The SGMII allows 10 Mbps, 100 Mbps, and 1000 Mbps throughput over 1000BASE-X line coding.

When SGMII Auto-Negotiation is turned off (3.3n00.12 = 0), the speed setting is programmed via register 3.3n00 bits 13 and 6. (n = 0, 2, 4, 6 for sub-ports 0, 1, 2, and 3, respectively). Link is established when the underlying 1000BASE-X establishes link.

When SGMII Auto-Negotiation is turned on (3.3n00.12 = 1), the SGMII is set to the speed setting is determined by the Auto-Negotiation speed advertised by the link partner if the device is in SGMII (System) mode. Auto-Negotiations have to complete prior to link being established.

2.500BASE-X is identical to 1000GBASE-X operation as described except it runs 2.5 times faster. Clause 37 Auto-Negotiation is not supported in 2.500BASE-X.

4.3.4.2 1000BASE-X Auto-Negotiation

1000BASE-X Auto-Negotiation is defined in Clause 37 of the IEEE 802.3 specification. It is used to auto-negotiate duplex and flow control over fiber cable. Registers 3.3n00, 3.3n04, 3.3n05, 3.3n06, 3.3n07, 3.3n08, and 3.3n0F are used to enable AN, advertise capabilities, determine the link partner's capabilities, show AN status, and show the duplex mode of operation, respectively.

The device supports Next Page option for 1000BASE-X Auto-Negotiation. Register 3.3n07 of the fiber pages is used to transmit Next Pages, and register 3.3n08 of the fiber pages is used to store the received Next Pages. The Next Page exchange occurs with software intervention. The user must set register 3.3n04.15 to enable fiber Next Page exchange. Each Next Page received in the registers should be read before a new Next Page to be transmitted is loaded in register 3.3n07.

If the PHY enables 1000BASE-X Auto-Negotiation and the link partner does not, then the link cannot be established. The device implements an Auto-Negotiation bypass mode. See [Section 4.3.4.4](#) for details.

4.3.4.3 SGMII Auto-Negotiation

SGMII is a de-facto standard designed by Cisco. SGMII uses 1000BASE-X coding to send data as well as Auto-Negotiation information between the PHY and the MAC. However, the contents of the SGMII Auto-Negotiation are different than the 1000BASE-X Auto-Negotiation. See the *Cisco SGMII Specification* and the *MAC Interfaces and Auto-Negotiation Application Note* for further details.

The device supports SGMII interface with and without Auto-Negotiation. Auto-Negotiation can be enabled or disabled by writing to Register 3.3n00.12 followed by a soft reset. If SGMII Auto-Negotiation is disabled, then the MAC interface link, speed, and duplex status (determined by the media side) cannot be conveyed to the MAC from the PHY. The user must program the MAC with this information in some other manner (for example, by reading PHY registers for link, speed, and duplex status).

4.3.4.4 Auto-Negotiation Bypass Mode

If the MAC or the PHY implements the Auto-Negotiation function and the other does not implement the function, then two-way communication is not possible unless Auto-Negotiation is manually disabled and both sides are configured to work in the same operational modes. To solve this problem, the device implements the SGMII Interface Auto-Negotiation Bypass Mode. When entering the state Ability_Detect, a bypass timer begins to count down from an initial value of approximately 200 ms. If the device receives idles during the 200 ms, then the device will interpret that the other side is live, but cannot send configuration codes to perform Auto-Negotiation. After 200 ms, the state machine will move to a new state called Bypass_Link_Up in which the device assumes a link-up status and the operational mode is set to the value listed under the Comments column of [Table 44](#).

Table 44: SGMII Auto-Negotiation Modes

Register 3.3n00.12	Register 3.Bn000.13	Comments
0	X	No Auto-Negotiation. The user is responsible for determining the speed, link, and duplex status by reading PHY registers.
1	0	Normal SGMII Auto-Negotiation. Speed, link, and duplex status are automatically communicated to the MAC during Auto-Negotiation.
1	1	Media Auto-Negotiation is enabled. Normal operation.
		Media Auto-Negotiation is disabled. After 200 ms, the PHY will disable Auto-Negotiation and the link based on idles.

4.4 Auto-Negotiation

The device supports 802.3ap Clause 73 Auto-Negotiation as well as the next pages required for the 25/50G consortium specifications. When the Auto-Negotiation configuration bits are set correctly and Auto-Negotiation is enabled, no further user intervention is required for Auto-Negotiation to complete.

There are four copies of the Auto-Negotiation circuit on the line interface. Sub-port 0 supports all abilities shown in [Table 40](#) with a Y in the last column. Sub-ports 1, 2, and 3 is similar to sub-port 0 except 40G, 50G, and 100G modes are not supported.

The enabling and disabling of the Auto-Negotiation circuit for each sub-port is discussed in [Section 4](#). If Auto-Negotiation is disabled and the device is manually set to a mode that KR training is required, then Auto-Negotiation will still run automatically. It is the user's responsibility to properly set the Auto-Negotiation registers to advertise only the capability that is consistent with the manually set mode.

The registers to control the 802.3ap Auto-Negotiation for sub-port 0 can be found starting at register 7.0000. The registers to control sub-port 0 consortium Auto-Negotiation can be found starting at register 7.8010. The registers for sub-port 1, 2, and 3 can be found in their corresponding offset addresses as mapped in the 88X5113 Registers documentation.

4.5 Loopback

4.5.1 Line-side Loopbacks

Figure 26 shows shallow line loopback (path A), deep loopbacks for line side. The deep loopback can be enabled at PCS to PMA boundary which is called PCS deep loopback (path B). The deep loopback can be at PMA to SERDES boundary so called PMA deep loopback (path C).

Table 45 shows how to turn on shallow line loopback. Table 46 shows how to turn on deep loopbacks for line side.

Figure 26: Line-side Loopback

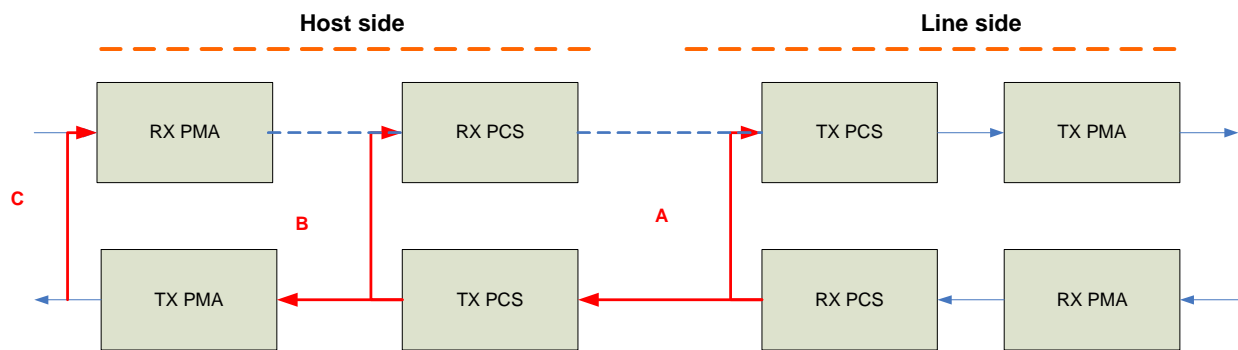

Table 45: Shallow Line Loopback Control Bits

Line Loopback Bits Description	Unit Affected	Register – Line
1G/2.5G, 5G/10G/25G lane 0, 40G/50G, 100G	Lane 0	Set 3.F010.12 = 1 (Loopback A in Figure 26)
1G/2.5G, 5G/10G/25G lane 1	Lane 1	Set 3.F010.13 = 1 (Loopback A in Figure 26)
1G/2.5G, 5G/10G/25G lane 2	Lane 2	Set 3.F010.14 = 1 (Loopback A in Figure 26)
1G/2.5G, 5G/10G/25G lane 3	Lane 3	Set 3.F010.15 = 1 (Loopback A in Figure 26)

The couple modes such as 40G/50G-R4, 50G-R2, and 100G-R4 always use lane 0.

Table 46: Deep Loopback Control Bits

Deep Loopback Bits Description	Unit Affected	Register – Line (PCS Deep Loopback)	Register – Line (PMA Deep Loopback)
Deep loopback – 100G	Lane 0	3.0000.14 (Loopback E in Figure 27)	1.0000.0 (Loopback F in Figure 27)
Deep loopback – 40G/50G	Lane 0	3.1000.14 (Loopback E in Figure 27)	1.2000.0 (Loopback F in Figure 27)
Deep loopback – 5G/10G/25G	Lane 0 Lane 1 Lane 2 Lane 3	3.2000.14 (Loopback E in Figure 27) 3.2200.14 3.2400.14 3.2600.11	1.4000.0 (Loopback F in Figure 27)
Deep loopback – 1G/2.5G	Lane 0 Lane 1 Lane 2 Lane 3	3.3000.14 3.3200.14 3.3400.14 (Loopback F in Figure 27) 3.3600.14	1.6000.0 (Loopback F in Figure 27)

4.5.2 Host-side Loopbacks

Figure 27 shows the paths for shallow host loopback (D), PCS deep loopback (E), and PMA deep loopback (F) for the host side.

Table 47 shows how to turn on a shallow host loopback. Table 48 shows how to turn on deep loopbacks for the host side.

Figure 27: Turn On Deep Host Loopback

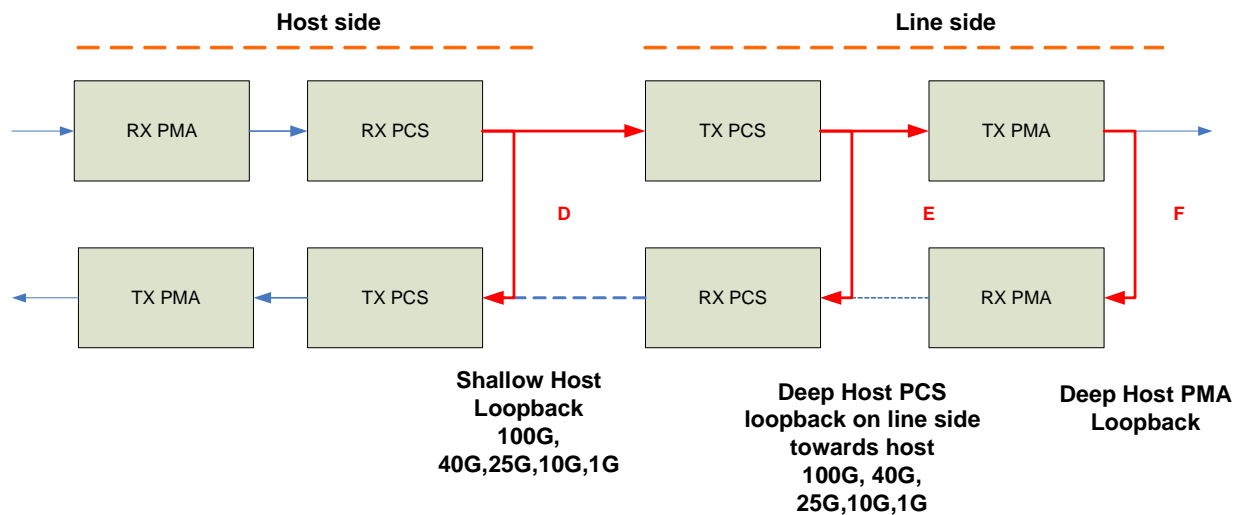

Table 47: Shallow Line Loopback Control Bits

Line Loopback Bits Description	Unit Affected	Register – Line
1G/2.5G, 5G/10G/25G lane 0, 40G/50G, 100G	Lane 0	Set 4.F010.12 = 1 (Loopback D in Figure 27).
1G/2.5G, 5G/10G/25G lane 1	Lane 1	Set 4.F010.13 = 1 (Loopback D in Figure 27).
1G/2.5G, 5G/10G/25G lane 2	Lane 2	Set 4.F010.14 = 1 (Loopback D in Figure 27).
1G/2.5G, 5G/10G/25G lane 3	Lane 3	Set 4.F010.15 = 1 (Loopback D in Figure 27).

The couple modes such as 40G/50G-R4, 50G-R2, and 100G-R4 always use lane 0.

Table 48: Deep Loopback Control Bits

Deep Loopback Bits Description	Unit Affected	Register – Line (PCS Deep Loopback)	Register – Line (PMA Deep Loopback)
Deep loopback – 100G	Lane 0	4.0000.14 (Loopback B in Figure 26)	1.1000.0 (Loopback C in Figure 26)
Deep loopback – 40G/50G	Lane 0	4.1000.14 (Loopback B in Figure 26)	1.3000.0 (Loopback C in Figure 26)
Deep loopback – 5G/10G/25G	Lane 0 Lane 1 Lane 2 Lane 3	4.2000.14 4.2200.14 4.2400.14 (Loopback B in Figure 26) 4.2600.11	1.5000.0 (Loopback C in Figure 26)
Deep loopback – 1G/2.5G	Lane 0 Lane 1 Lane 2 Lane 3	4.3000.14 4.3200.14 4.3400.14 4.3600.14 (Loopback B in Figure 26)	1.7000.0 (Loopback C in Figure 26)

4.6 Synchronized FIFO

There is a transmit synchronizing FIFO in all PCS including 1G, 10G, 25G, 40G/50G, and 100G PCS. Each of the FIFOs reconciles the frequency differences between the internal bus clock and the clock used to transmit data onto the media interface. It also buffers the data when inserting Alignment Maker. Each of the FIFOs can support a maximum frame size of 10 KB with up to ±100 PPM clock jitter.

4.7 Traffic Generation and Checking

There are several packet generator and checkers in the device. There are 22 16-bit registers associated with each generator and checker. This section will refer to these registers as R00 to R21. The register mapping is shown in [Table 49](#).

Table 49: Packet Generator and Checker Register Mapping¹ Data

Register	Description	P100*	P40*, P50*	P5*, P10*, P25*	P1*, P2.5*
R00	Packet Generation Control 1	3.8100	3.9010	3.An10	3.Bn10
R01	Packet Generation Control 2	3.8101	3.9011	3.An11	3.Bn11
R02	Initial Payload 0-1/Packet Generation	3.8102	3.9012	3.An12	3.Bn12
R03	Initial Payload 2-3/Packet Generation	3.8103	3.9013	3.An13	3.Bn13
R04	Packet Generation Length	3.8106	3.9016	3.An16	3.Bn16
R05	Packet Generation Burst Sequence	3.8107	3.9017	3.An17	3.Bn17
R06	Packet Generation IPG	3.8108	3.9018	3.An18	3.Bn18
R07	Transmit Packet Counter [15:0]	3.810B	3.901B	3.An1B	3.Bn1B
R08	Transmit Packet Counter [31:16]	3.810C	3.901C	3.An1C	3.Bn1C
R09	Transmit Packet Counter [47:32]	3.810D	3.901D	3.An1D	3.Bn1D
R10	Transmit Byte Counter [15:0]	3.810E	3.901E	3.An1E	3.Bn1E
R11	Transmit Byte Counter [31:16]	3.810F	3.901F	3.An1F	3.Bn1F
R12	Transmit Byte Counter [47:32]	3.8110	3.9020	3.An20	3.Bn20
R13	Receive Packet Counter [15:0]	3.8111	3.9021	3.An21	3.Bn21
R14	Receive Packet Counter [31:16]	3.8112	3.9022	3.An22	3.Bn22
R15	Receive Packet Counter [47:32]	3.8113	3.9023	3.An23	3.Bn23
R16	Receive Byte Count [15:0]	3.8114	3.9024	3.An24	3.Bn24
R17	Receive Byte Count [31:16]	3.8115	3.9025	3.An25	3.Bn25
R18	Receive Byte Count [47:32]	3.8116	3.9026	3.An26	3.Bn26
R19	Receive Packet Error Count [15:0]	3.8117	3.9027	3.An27	3.Bn27

Table 49: Packet Generator and Checker Register Mapping¹ Data (Continued)

Register	Description	P100*	P40*, P50*	P5*, P10*, P25*	P1*, P2.5*
R20	Receive Packet Error Count [31:16]	3.8118	3.9028	3.An28	3.Bn28
R21	Receive Packet Error Count [47:32]	3.8119	3.9029	3.An29	3.Bn29

1. N = 0, 2, 4, 6 for sub-ports 0, 1, 2, and 3, respectively.

The packet generator and packet checker are enabled by separate control bits – R00.0 controls the packet checker and R00.1 controls the packet generator. (Table 50).

When the packet Generator is enabled, packet stream is generated and a pair of 48-bit counters tracks the packet stream. Transmit Packet Counter (R07, R08, and R09) counts number of packets sent. Transmit Byte Counter (R10, R11, and R12) counts number of bytes sent.

Similarly, when the packet checker is enabled, received packets are examined and a set of three 48-bit counters are updated. Received Packet Counter (R13, R14, and R15) counts number of packets received. Received Byte Counter (R16, R17, and R18) counts number of bytes received, and Received Error Counter (R19, R20, and R21) counts number of received packets with CRC error.

Table 50: Packet Generator and Checker Control and Counters

Register	Function	Description
R00.0	Enable Packet Checker	1: Packet Checker is enabled. 0: Packet Checker is disabled.
R00.1	Enable Packet Generator	1: Packet Generator is enabled. 0: Packet Generator is disabled.
R00.6	Counter reset	1: Clear counters. 0: Normal operation This bit clears itself after counter reset.
R00.15	Counter reset on read	1: Clear the counter as it is read. 0: The counter value is not cleared when it is read.
R07 R08 R09	Transmit Packet Counter	These are the 48-bit Tx packet counters, they are incremented as each packet is sent. A reset of these counters is controlled by the Counter reset bit (R00.6) and the Counter reset on read bit (R00.15) above.
R10 R11 R12	Transmit Byte Counter	These are the 48-bit Tx byte counters, they are incremented as each data byte is sent, including CRC bytes. A reset of these counters is controlled by the Counter reset bit (R00.6) and the Counter reset on read bit (R00.15) above.
R13 R14 R15	Received Packet Counter	These are the 48-bit Rx packet counters, they are incremented as each packet is received. A reset of these counters is controlled by the Counter reset bit (R00.6) and the Counter reset on read bit (R00.15) above.

Table 50: Packet Generator and Checker Control and Counters (Continued)

Register	Function	Description
R16 R17 R18	Received Byte Counter	These are the 48-bit Rx byte counters, they are incremented as each data byte is received, including CRC bytes. A reset of these counters is controlled by the Counter reset bit (R00.6) and the Counter reset on read bit (R00.15) above.
R19 R20 R21	Received Error Counter	These are the 48-bit Rx error counters, they are incremented as each packet is received with a CRC error. A reset of these counters is controlled by the Counter reset bit (R00.6) and the Counter reset on read bit (R00.15) above.

4.7.1 Packet Generator

A packet generator enables the device to generate traffic onto the media without a requirement to receive data from the host.

As a reference, the following depicts the basic structure of Packet Generator output in XLGMII (40G) and CGMII (100G) format.

Figure 28: Packet Format

TXC[7:0]	TXD[63:0]	Bit 0 is first bit shifted out. Packet starts at CGMII boundary of 64 bit.
01	<sfid> 55 55 55 55 55 55 [S]	Lane0 [S] = 0xFB. Lane7 <sfid> = 0xD5
00	(data 7) – (data 0)	n bytes of data specified by Packet Length register
00	••••••••	
00	(data n-2) ••••••••	
E0	[I] [I] [T] (crc[31:0]) (data n-1)	[T] = 0xFD [I] = 0x07

Table 51: Registers Controlling Packet Generation

Register	Function	Description
R00.1	Enable Packet Generator	1: The packet generator is enabled. 0: The packet generator is disabled.
R01.3	CRC Disable	{CRC,SFD}=00: CRC calculation is enabled and CGMII word 0 lane 7 <sfid> = 0xD5. CRC calculation starts after <sfid> byte in packet
R00.2	SFD Enable	{CRC,SFD}=01: CRC calculation is enabled and CGMII word 0 lane 7 <preA> = 0x55. CRC calculation start after 8th byte in packet
		{CRC,SFD}=11: Extended CRC calculation is enabled and CGMII word 0 lane 7 <preA> = 0x55. Extended CRC calculation starts after [S] byte. NOTE: Extended CRC function is only available in 40G and 100G modes.
		{CRC,SFD}=10: CRC calculation is disabled and CGMII word 0 lane 7 <sfid> = 0xD5.
R04	Packet Length	0x0000: Random length between 64 bytes to 1518 bytes 0x0001: Random length between 64 bytes to 0x0FFF bytes 0x0002: Random length between 64 bytes to 0x1FFF bytes 0x0003: Random length between 64 bytes to 0x3FFF bytes 0x0004: Random length between 64 bytes to 0x7FFF bytes 0x0005: Random length between 64 bytes to 0xFFFF bytes 0x0006 – 0x0007: undefined 0x0008 – 0xFFFF = length in number of bytes.
R05	Number of Packets to Generate	0x0000: Stop generation 0x0001 – 0xFFFF: number of packets to send 0xFFFF = Continuous

Figure 29: Normal CRC Calculation (in XLGMII/40G and CGMII/100G Format)

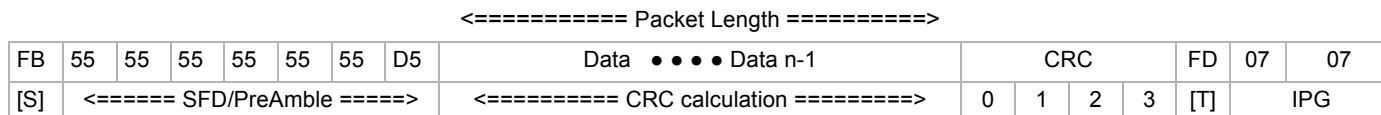

Figure 30: Extended CRC Calculation (in XLGMII/40G and CGMII/100G Format)

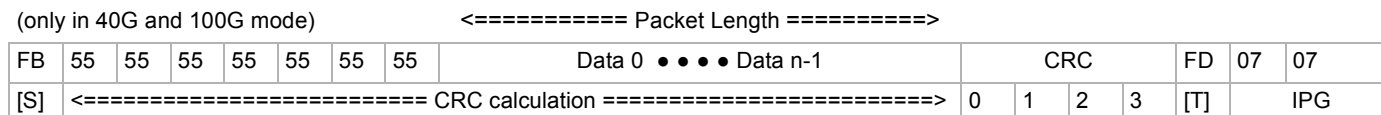

Figure 31: Packet without CRC (in XLGMII/40G and CGMII/100G Format)

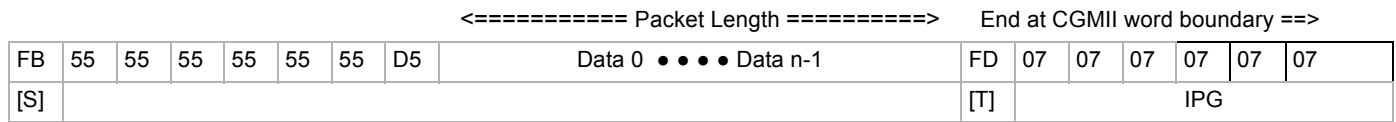

Table 52: IPG Configuration

Register #	Function	Description
R06	Inter Packet Gap (IPG)	<p>IPG.15:14 = 00: Fixed number of idle bytes is specified by IPG.13:0 For P100*, P50* and P40* modes, IPG is in 8-byte resolution (1 CGMII word). For example: IPG.13:0 = 0x0000 – 0x0007: Next packet starts at the following CGMII word (next 8byte boundary) IPG.13:0 = 0x0008 – 0x000F: After the end of current packet 8-byte boundary, insert 1 CGMII (8 byte) idle before start of next packet. IPG.13:0 = 0x0010 – 0x00017: After the end of current packet 8-byte boundary, insert 2 CGMII (16 byte) idle before start of next packet. For 10G, the resolution is 4 bytes.</p> <p>IPG.15:14 = 10: Random number of IPG up to the value specified by IPG.13:0</p> <p>IPG.15:14 = 01: Deficit Idle Count specified by IPG.13:0. Valid IPG.13:0 value is limited to minimum of 8 and maximum of 20. NOTE: Idle Deficit function only available in 40G/50G and 100G modes.</p> <p>IPG.15:14 = 11: Zero IPG. 1 CGMII word (8 byte) of idle is inserted after n bytes of data, n is specified by IPG.13:0 as following: IPG.13:0 = 0x0080: n = 128 bytes IPG.13:0 = 0x0100: n = 256 bytes IPG.13:0 = 0x0200: n = 512 bytes IPG.13:0 = 0x0400: n = 1024 bytes IPG.13:0 = 0x0800: n = 2048 bytes IPG.13:0 = 0x1000: n = 4096 bytes IPG.13:0 = 0x2000: n = 8196 bytes NOTE: Zero IPG function only available in 40G/50G and 100G modes.</p>
R07 R08 R09	Transmit Packet Counter	These are the 48-bit Tx packet counters, they are incremented as each packet is sent.
R10 R11 R12	Transmit Byte Counter	These are the 48-bit Tx byte counters, they are incremented as each data byte is sent, including 4 CRC bytes.

Table 53: Packet Data Generation

Register #	Function	Description
R02 R03	Initial Generation	Initial Payload register specifies the initial value of the payload or the fixed value of the payload. The four bytes in this register corresponds to the first 4 bytes of the frame data.
R01	Data Generation	0x0 or 0x1: No mask Value of Initial Payload registers are used as payload repeatedly.
		0x2: Invert every other word Value of Initial Payload registers are used as payload repeatedly but every other CGMII word should be inverted. For example: A payload of 034EA675 will result in a sequence of 034EA675, FCB1598A, 034EA675, FCB1598A, and so on.
		0x3: Invert every second word Value of Initial Payload registers are used as payload repeatedly but inverted every second CGMII word should be inverted. For example: A payload of 034EA675 will result in a sequence of 034EA675, 034EA675, FCB1598A, FCB1598A, 034EA675, 034EA675, and so on.
		0x4: Left shift byte Value of Initial Payload registers are used as the initial value and each byte subsequently bitwise left shifted. For example: A payload of 034EA675 will result in a sequence of 034EA675, 069C4DEA, 0C399AD5, 187235AB, and so on.
		0x5: Right shift byte Value of Initial Payload registers are used as the initial value and each byte subsequently bitwise right shifted.
		0x6: Left shift word Value of Initial Payload registers are used as the initial value and each 32-bit word subsequently bitwise left shifted. For example: A payload of C34EA675 will result in a sequence of C34EA675, 869D4CEB, 0D3A99D7, 1A7533AE, and so on.
		0x7: Right shift word Value of Initial Payload registers are used as the initial value and each 32-bit word subsequently bitwise right shifted.
		0x8: Increment byte Value of Initial Payload registers are used as the initial value and subsequently bitwise incremented. For example: A payload of FFFE0055 will result in a sequence of FFFE0055, 00FF0156, 01000257, 02010358, and so on.
		0x9: Decrement byte Value of Initial Payload registers are used as the initial value and subsequently bitwise decremented.
		0xA: Pseudo-random byte Initial Payload registers are ignored and a pseudo-random payload is generated. All 4 bytes are the same value for each cycle.
		0xB: Pseudo-random word Initial Payload registers are ignored and a pseudo-random payload is generated. All 4 bytes are randomly generated for each cycle.
		0xC – 0xF: Reserved

4.7.2 Packet Checker

Table 54: Registers Controlling Packet Checker

Register #	Function	Description
R00.0	Enable Packet Checker	1: Packet Checker is enabled. 0: Packet Checker is disabled.
R01.3	CRC disable	{CRC,SFD}=00: CRC calculation is enabled and started after detection of frame delimiter <sfd>
R00.2	SFD enable	{CRC,SFD}=01: CRC calculation is enabled and started after eight byte of the packet. The checker assumes the first 8 bytes of packet is the preamble.
		{CRC,SFD}=11: Extended CRC calculation is enabled and started after second byte of the packet. NOTE: Extended CRC function only available in 40G and 100G modes.
		{CRC,SFD}=10: CRC calculation is disabled and data field starts after detection of frame delimited <sfd>
R13 R14 R15	Received Packet Counter	These are 48-bit Rx packet counters, they are incremented as each packet is received.
R16 R17 R18	Received Byte Counter	These are 48-bit Rx byte counters, they are incremented as each data byte is received, including 4 CRC bytes.
R19 R20 R21	Received Error Counter	These are 48-bit Rx error counters, they are incremented as each packet is received with a CRC error.

4.8 PRBS Generation and Checking

The device supports various IEEE defined and proprietary PRBS generators and checkers, and transmit waveform pattern generators. Only one generator and checker may be enabled at a time per lane. Unpredictable results may occur if multiple generators are enabled simultaneously.

4.8.1 General PRBS Generators and Checkers

Each lane has its own general PRBS generator and checker. The register definitions for all PRBSs are same except for register offsets. [Table 55](#) shows all PRBS register address offsets. Lane 0 PRBS register address will be used to describe the functionality of PRBS generator and checkers.

To maintain consistency, the address offsets for the host side are listed here.

Table 55: PRBS Register Address Offsets

Register	Description	Line Side				Host Side			
		L0	L1	L2	L3	L0	L1	L2	L3
R0	PRBS control	3.F100	3.F110	3.F120	3.F130	4.F100	4.F110	4.F120	4.F130
R1	Transmit bit counter	3.F101	3.F111	3.F121	3.F131	4.F101	4.F111	4.F121	4.F131
R2		3.F102	3.F112	3.F122	3.F132	4.F102	4.F112	4.F122	4.F132
R3		3.F103	3.F113	3.F123	3.F133	4.F103	4.F113	4.F123	4.F133
R4	Receive bit counter	3.F104	3.F114	3.F124	3.F134	4.F104	4.F114	4.F124	4.F134
R5		3.F105	3.F115	3.F125	3.F135	4.F105	4.F115	4.F125	4.F135
R6		3.F106	3.F116	3.F126	3.F136	4.F106	4.F116	4.F126	4.F136
R7	Receive error counter	3.F107	3.F117	3.F127	3.F137	4.F107	4.F117	4.F127	4.F137
R8		3.F108	3.F118	3.F128	3.F138	4.F108	4.F118	4.F128	4.F138
R9		3.F109	3.F119	3.F129	3.F139	4.F109	4.F119	4.F129	4.F139

Register 3.F100 controls the generator and checker. Setting register 3.F100.5 to 1 enables the generator, and setting register 3.F100.4 to 1 enables the checker. If either of these bits is set to 1, then the general PRBS generator and checker overrides the PCS-specific generators and checkers. The port should be set to the selected PCS mode before enabling the PRBS mode to achieve the desired line rate for PRBS testing. When PRBS is enabled, this has higher priority over PCS datapath. Register 3.F100.3:0 controls the pattern that is generated and checked. There is no checker for the high-frequency, low-frequency, mixed-frequency, and square-wave patterns as there are waveforms to check the transmitter performance.

Table 56: Supported Line-side PRBS Patterns

3.F100.3:0	PRBS Pattern Format
0000	IEEE 49.2.8 - PRBS 31
0001	PRBS 7
0010	PRBS 9 IEEE 83.7
0011	PRBS 23
0100	PRBS 31 Inverted
0101	PRBS 7 Inverted
1000	PRBS 15
1001	PRBS 15 Inverted
0110	PRBS 9 Inverted
0111	PRBS 23 Inverted
1010	PRBS 58
1011	PRBS 58 Inverted
1100	PRBS 13
1101	PRBS 13 Inverted
1110	JB03 register address Lane 0 pattern A 3.F10A pattern B 3.F10B Lane 1 pattern A 3.F11A pattern B 3.F11B Lane 2 pattern A 3.F12A pattern B 3.F12B Lane 3 pattern A 3.F13A pattern B 3.F13B
1111	Line-side PRBS square-wave pattern consists of 10 1's followed by 10 0's.

All counters are 48 bits long. If register 3.F100.13 is set to 1, then the counters will clear on read. If register 3.F100.13 is set to 0, then the counters continue counting until register 3.F100.6 is set to 1 to clear the contents. If register 3.F100.7 is set to 0, then the PRBS counters will not start to count until the checker first locks onto the incoming PRBS data. If register 3.F100.7 is set to 1, then the PRBS checker will start counting errors without first locking to the incoming PRBS data. Register 3.F100.8 indicates whether the PRBS checker has locked. All 48-bit counters are formed by three 16-bit registers. The lowest addressed register is the least significant 16 bits and the highest addressed register is the most significant 16 bits of the counter. When the least significant register is read, the two upper registers are updated and frozen so that the three register read is atomic. It is not necessary to read the upper registers. However, on subsequent reads of the least significant register, the values of the upper registers from the previous reads are lost. To get the correct upper register value the least significant register must be read first. Register 3.F101, 3.F102, and 3.F103 is the transmit bit counter. Registers 3.F104, 3.F105, and 3.F106 is the receive bit counter. Registers 3.F107, 3.F108, and 3.F109 is the receive bit error counter.

4.8.2 40GBASE-R4-specific Generators and Checkers

Register 1.05DD.7 when set to 1 selects PRBS31 pattern. Registers 1.05DD.3 when set to 1 enables Tx generator. Register 1.05DD.0 when set to 1 enables Rx checker. The error counters for individual lanes are in register 1.06A4, 1.06A5, 1.06A6, and 1.06A7, which will be cleared on read.

Register 1.05DD.6 when set to 1 selects PRBS9 pattern. Registers 1.05DD.3 when set to 1 enables Tx generator.

Register 1.05E6.3:0 when set to 1 selects SW (square wave) pattern for individual lanes.

The Line Side Lane 0 to Lane 3 Registers are 3.F100, 3.F110, 3.F120, and 3.F130, respectively.

4.8.3 100GBASE-R4-specific Generators and Checkers

Register 1.05DD.7 when set to 1 selects PRBS31 pattern. Registers 1.05DD.3 when set to 1 enables Tx generator. Register 1.05DD.0 when set to 1 enables Rx checker. The error counters for individual lanes are in registers 1.06A4, 1.06A5, 1.06A6, and 1.06A7, which will be cleared on read.

Register 1.05DD.6 when set to 1 selects PRBS9 pattern. Registers 1.05DD.3 when set to 1 enables Tx generator.

Register 1.05E6.3:0 when set to 1 selects SW (square wave) pattern for individual lanes.

[Table 57](#) lists IEEE registers to control PRBS.

Table 57: IEEE PCS and PMA PRBS Control Register

	Line Side	Host Side
PCS 10G/25G lane 0	3.202A, 3.202B	4.202A, 4.202B
PCS 10G/25G lane 1	3.222A, 3.222B	4.222A, 4.222B
PCS 10G/25G lane 2	3.242A, 3.242B	4.242A, 4.242B
PCS 10G/25G lane 3	3.262A, 3.262B	4.262A, 4.262B
PMA lane 0	1.05DD, 1.05E6, 1.06A4-7	1.15DD, 1.15E6, 1.16A4-7
PMA lane 1	1.25DD, 1.25E6, 1.26A4-7	1.35DD, 1.35E6, 1.36A4-7
PMA lane 2	1.45DD, 1.45E6, 1.46A4-7	1.55DD, 1.55E6, 1.56A4-7
PMA lane 3	1.65DD, 1.65E6, 1.66A4-7	1.75DD, 1.75E6, 1.76A4-7

4.9 Eye Monitor

Each lane has its own non-destructive eye monitor to determine the quality of the received signal in traffic mode.

5 Host Side Description

The host interface functionality is identical to the line interface in [Section 4](#) with the following exceptions.

The host interface comprises four differential input lanes and four differential output lanes.

All line side registers have equivalent registers in the host side as shown in [Table 58](#). The address either has a different DEVAD or an offset in the REGAD. All the description of the line interface functionality in [Section 4](#) applies to the host interface except for the register address location.

Table 58: Equivalent Registers Between Line and Host Interface

Line Interface		Host Interface		Description
Start	End	Start	End	--
1.0000	1.00FF	1.1000	1.10FF	PMA (IEEE) Sub-Port 0
1.2000	1.20FF	1.3000	1.30FF	PMA (IEEE) Sub-Port 1
1.4000	1.40FF	1.5000	1.50FF	PMA (IEEE) Sub-Port 2
1.6000	1.60FF	1.7000	1.70FF	PMA (IEEE) Sub-Port 3
1.8000	1.80FF	1.9000	1.90FF	PMA FEC (IEEE) Sub-Port 0
1.0100	1.01FF	1.1100	1.11FF	PMA (IEEE) Sub-Port 0
1.2100	1.21FF	1.3100	1.31FF	PMA (IEEE) Sub-Port 1
1.4100	1.41FF	1.5100	1.51FF	PMA (IEEE) Sub-Port 2
1.6100	1.61FF	1.7100	1.71FF	PMA (IEEE) Sub-Port 3
1.8100	1.80FF	1.9100	1.90FF	PMA FEC (IEEE) Sub-Port 0
1.0200	1.02FF	1.1200	1.12FF	PMA (IEEE) Sub-Port 0
1.2200	1.22FF	1.3200	1.32FF	PMA (IEEE) Sub-Port 1
1.4200	1.42FF	1.5200	1.52FF	PMA (IEEE) Sub-Port 2
1.6200	1.62FF	1.7200	1.72FF	PMA (IEEE) Sub-Port 3
1.0300	1.03FF	1.1300	1.13FF	PMA (IEEE) Sub-Port 0
1.2300	1.23FF	1.3300	1.33FF	PMA (IEEE) Sub-Port 1
1.4300	1.43FF	1.5300	1.53FF	PMA (IEEE) Sub-Port 2
1.6300	1.63FF	1.7300	1.73FF	PMA (IEEE) Sub-Port 3
1.0400	1.04FF	1.1400	1.14FF	PMA (IEEE) Sub-Port 0
1.2400	1.24FF	1.3400	1.34FF	PMA (IEEE) Sub-Port 1

Table 58: Equivalent Registers Between Line and Host Interface (Continued)

Line Interface		Host Interface		Description
Start	End	Start	End	--
1.4400	1.44FF	1.5400	1.54FF	PMA (IEEE) Sub-Port 2
1.6400	1.64FF	1.7400	1.74FF	PMA (IEEE) Sub-Port 3
1.0500	1.05FF	1.1500	1.15FF	PMA (IEEE) Sub-Port 0
1.2500	1.25FF	1.3500	1.35FF	PMA (IEEE) Sub-Port 1
1.4500	1.45FF	1.5500	1.55FF	PMA (IEEE) Sub-Port 2
1.6500	1.65FF	1.7500	1.75FF	PMA (IEEE) Sub-Port 3
1.0600	1.06FF	1.1600	1.16FF	PMA (IEEE) Sub-Port 0
1.2600	1.26FF	1.3600	1.36FF	PMA (IEEE) Sub-Port 1
1.4600	1.46FF	1.5600	1.56FF	PMA (IEEE) Sub-Port 2
1.6600	1.66FF	1.7600	1.76FF	PMA (IEEE) Sub-Port 3
1.C000	1.C0FF	1.D000	1.D0FF	PMA (Marvell) Sub-Port 0
1.C200	1.C2FF	1.D200	1.D2FF	PMA (Marvell) Sub-Port 1
1.C400	1.C4FF	1.D400	1.D4FF	PMA (Marvell) Sub-Port 2
1.C600	1.C6FF	1.D600	1.D6FF	PMA (Marvell) Sub-Port 3
1.C800	1.C8FF	1.D800	1.D8FF	PMA (Marvell) All ports
1.C100	1.C1FF	1.D100	1.D1FF	PMA (Marvell) Sub-Port 0
1.C300	1.C3FF	1.D300	1.D3FF	PMA (Marvell) Sub-Port 1
1.C500	1.C5FF	1.D500	1.D5FF	PMA (Marvell) Sub-Port 2
1.C700	1.C7FF	1.D700	1.D7FF	PMA (Marvell) Sub-Port 3
1.C900	1.C9FF	1.D900	1.D9FF	PMA (Marvell) All ports
1.CB00	1.CBFF	1.DB00	1.DBFF	PMA (Marvell) All ports
1.CD00	1.CDFF	1.DD00	1.DDFF	PMA (Marvell) All ports
1.CF00	1.CFFF	1.DF00	1.DFFF	PMA (Marvell) All ports
3.4000	3.40FF	4.4000	4.40FF	200GBASE-R4 (IEEE)
3.4100	3.41FF	4.4100	4.41FF	200GBASE-R4 (IEEE)
3.3000	3.30FF	4.3000	4.30FF	1/2.5GBASE-R (IEEE) Sub-Port 0
3.3200	3.32FF	4.3200	4.32FF	1/2.5GBASE-R (IEEE) Sub-Port 1
3.3400	3.34FF	4.3400	4.34FF	1/2.5GBASE-R (IEEE) Sub-Port 2

Table 58: Equivalent Registers Between Line and Host Interface (Continued)

Line Interface		Host Interface		Description
Start	End	Start	End	--
3.3600	3.36FF	4.3600	4.36FF	1/2.5GBASE-R (IEEE) Sub-Port 3
3.3100	3.31FF	4.3100	4.31FF	1/2.5GBASE-R (IEEE) Sub-Port 0
3.3300	3.33FF	4.3300	4.33FF	1/2.5GBASE-R (IEEE) Sub-Port 1
3.3500	3.35FF	4.3500	4.35FF	1/2.5GBASE-R (IEEE) Sub-Port 2
3.3700	3.37FF	4.3700	4.37FF	1/2.5GBASE-R (IEEE) Sub-Port 3
3.2000	3.20FF	4.2000	4.20FF	5/10/25GBASE-R (IEEE) Sub-Port 0
3.2200	3.22FF	4.2200	4.22FF	5/10/25GBASE-R (IEEE) Sub-Port 1
3.2400	3.24FF	4.2400	4.24FF	5/10/25GBASE-R (IEEE) Sub-Port 2
3.2600	3.26FF	4.2600	4.26FF	5/10/25GBASE-R (IEEE) Sub-Port 3
3.2100	3.21FF	4.2100	4.21FF	5/10/25GBASE-R (IEEE) Sub-Port 0
3.2310	3.23FF	4.2310	4.23FF	5/10/25GBASE-R (IEEE) Sub-Port 1
3.2500	3.25FF	4.2500	4.25FF	5/10/25GBASE-R (IEEE) Sub-Port 2
3.2700	3.27FF	4.2700	4.27FF	5/10/25GBASE-R (IEEE) Sub-Port 3
3.1000	3.10FF	4.1000	4.10FF	40GBASE-R4 (IEEE) Sub-Port 0
3.1200	3.12FF	4.1200	4.12FF	40GBASE-R4 (IEEE) Sub-Port 1
3.1400	3.14FF	4.1400	4.14FF	40GBASE-R4 (IEEE) Sub-Port 2
3.1600	3.16FF	4.1600	4.16FF	40GBASE-R4 (IEEE) Sub-Port 3
3.1100	3.11FF	4.1100	4.11FF	40GBASE-R4 (IEEE) Sub-Port 0
3.1300	3.13FF	4.1300	4.13FF	40GBASE-R4 (IEEE) Sub-Port 1
3.1500	3.15FF	4.1500	4.15FF	40GBASE-R4 (IEEE) Sub-Port 2
3.1700	3.17FF	4.1700	4.17FF	40GBASE-R4 (IEEE) Sub-Port 3
3.0000	3.00FF	4.0000	4.00FF	100GBASE-R4 (IEEE) sub-port 0
3.0400	3.04FF	4.0400	4.04FF	100GBASE-R4 (IEEE) sub-port 1
3.0500	3.05FF	4.0100	4.01FF	100GBASE-R4 (IEEE) sub-port 0
3.0100	3.05FF	4.0500	4.05FF	100GBASE-R4 (IEEE) sub-port 1
3.0700	3.07FF	4.0700	4.07FF	100GBASE-R4 (IEEE) sub-port 0
3.0B00	3.0BFF	4.0B00	4.0BFF	100GBASE-R4 (IEEE) sub-port 1
3.C000	3.C0FF	4.C000	4.C0FF	200GBASE-R4 (Marvell)

Table 58: Equivalent Registers Between Line and Host Interface (Continued)

Line Interface		Host Interface		Description
Start	End	Start	End	--
3.C100	3.C1FF	4.C100	4.C1FF	200GBASE-R4 (Marvell)
3.B000	3.B0FF	4.B000	4.B0FF	1/2.5GBASE-R (Marvell) Sub-Port 0
3.B200	3.B2FF	4.B200	4.B2FF	1/2.5GBASE-R (Marvell) Sub-Port 1
3.B400	3.B4FF	4.B400	4.B4FF	1/2.5GBASE-R (Marvell) Sub-Port 2
3.B600	3.B6FF	4.B600	4.B6FF	1/2.5GBASE-R (Marvell) Sub-Port 3
3.B100	3.B1FF	4.B100	4.B1FF	1/2.5GBASE-R (Marvell) Sub-Port 0
3.B300	3.B3FF	4.B300	4.B3FF	1/2.5GBASE-R (Marvell) Sub-Port 1
3.B500	3.B5FF	4.B500	4.B5FF	1/2.5GBASE-R (Marvell) Sub-Port 2
3.B700	3.B7FF	4.B700	4.B7FF	1/2.5GBASE-R (Marvell) Sub-Port 3
3.A000	3.A0FF	4.A000	4.A0FF	5/10/25GBASE-R (Marvell) Sub-Port 0
3.A200	3.A2FF	4.A200	4.A2FF	5/10/25GBASE-R (Marvell) Sub-Port 1
3.A400	3.A4FF	4.A400	4.A4FF	5/10/25GBASE-R (Marvell) Sub-Port 2
3.A600	3.A6FF	4.A600	4.A6FF	5/10/25GBASE-R (Marvell) Sub-Port 3
3.A100	3.A1FF	4.A100	4.A1FF	5/10/25GBASE-R (Marvell) Sub-Port 0
3.A300	3.A3FF	4.A300	4.A3FF	5/10/25GBASE-R (Marvell) Sub-Port 1
3.A500	3.A5FF	4.A500	4.A5FF	5/10/25GBASE-R (Marvell) Sub-Port 2
3.A700	3.A7FF	4.A700	4.A7FF	5/10/25GBASE-R (Marvell) Sub-Port 3
3.9000	3.90FF	4.9000	4.90FF	40GBASE-R4 (Marvell) Sub-Port 0
3.9200	3.92FF	4.9200	4.92FF	40GBASE-R4 (Marvell) Sub-Port 1
3.9400	3.94FF	4.9400	4.94FF	40GBASE-R4 (Marvell) Sub-Port 2
3.9600	3.96FF	4.9600	4.96FF	40GBASE-R4 (Marvell) Sub-Port 3
3.9100	3.91FF	4.9100	4.91FF	40GBASE-R4 (Marvell)
3.8000	3.80FF	4.8000	4.80FF	100GBASE-R4 (Marvell)
3.8100	3.81FF	4.8000	4.80FF	100GBASE-R4 (Marvell)
3.F000	3.F0FF	4.F000	4.F0FF	Line or Host Common
3.F100	3.F1FF	4.F100	4.F1FF	Line or Host Common
7.0000	7.00FF	7.1000	7.10FF	AP Auto-Negotiation (IEEE) Sub-Port 0
7.0200	7.02FF	7.1200	7.12FF	AP Auto-Negotiation (IEEE) Sub-Port 1

Table 58: Equivalent Registers Between Line and Host Interface (Continued)

Line Interface		Host Interface		Description
Start	End	Start	End	--
7.0400	7.04FF	7.1400	7.14FF	AP Auto-Negotiation (IEEE) Sub-Port 2
7.0600	7.06FF	7.1600	7.16FF	AP Auto-Negotiation (IEEE) Sub-Port 3
7.0100	7.01FF	7.1100	7.11FF	AP Auto-Negotiation (IEEE) Sub-Port 0
7.0300	7.03FF	7.1300	7.13FF	AP Auto-Negotiation (IEEE) Sub-Port 1
7.0500	7.05FF	7.1500	7.15FF	AP Auto-Negotiation (IEEE) Sub-Port 2
7.0700	7.07FF	7.1700	7.17FF	AP Auto-Negotiation (IEEE) Sub-Port 3
7.8000	7.80FF	7.9000	7.90FF	AP Auto-Negotiation (Marvell) Sub-Port 0
7.8200	7.82FF	7.9200	7.92FF	AP Auto-Negotiation (Marvell) Sub-Port 1
7.8400	7.84FF	7.9400	7.94FF	AP Auto-Negotiation (Marvell) Sub-Port 2
7.8600	7.86FF	7.9600	7.96FF	AP Auto-Negotiation (Marvell) Sub-Port 3
7.8100	7.81FF	7.9100	7.91FF	AP Auto-Negotiation (Marvell) Sub-Port 0
7.8300	7.83FF	7.9300	7.93FF	AP Auto-Negotiation (Marvell) Sub-Port 1
7.8500	7.85FF	7.9500	7.95FF	AP Auto-Negotiation (Marvell) Sub-Port 2
7.8700	7.87FF	7.9700	7.97FF	AP Auto-Negotiation (Marvell) Sub-Port 3
30.0000	30.7FFF	30.8000	30.FFFF	SERDES Access

In most cases, the data flow between the line and host are symmetrical and the mode settings for line and host are interchangeable. The configurations shown in [Table 59](#) are not reversible.

The SGMII (PHY) mode is used on the host interface instead of the SGMII (System) mode. When SGMII Auto-Negotiation is turned on ($4.3n00.12 = 1$, $n = 0, 2, 4, 6$ for sub-ports 0, 1, 2, 3 respectively), the speed advertised is set by the operational speed of the corresponding sub-port on the line interface.

Table 59: Non-Reversible Mode Combinations

Line	Host
P1S	P1P
P25*	P40*

6 Chip Bring Up

The chip bring up process involves applying power and supplying a clock to the device, hardware resetting and configuring the device, load the firmware either through the EEPROM, or through the MDIO/TWSI slave, and finally configuring the registers and engaging the data path. The firmware will be reset by hardware reset. Firmware requires a reload if a hardware reset is issued.

6.1 Power Sequencing

VDDON, VDDOS, AVDDL, AVDDH, AVDDC, and DVDD is applied to the device and the 156.25 MHz differential clock is applied to the CLKP/CLKN pins. This device requires no power up sequencing. However, the recommendation is to power up VDDO and AVDDT first, followed by AVDDH/L/C, followed by DVDD.

If the 25 MHz output clock is to be used on the CLK25P/CLK25N pins, then the AVDDT supply should be tied to 3.3V or 2.5V. Otherwise, it should be AC coupled to ground. AVDDT can be combined with VDDON and VDDOS but with a filtering scheme.

After all the power supplies stabilize, the 25 MHz clock will be stable 7 to 10 ms after the 156.25 MHz clock is stable. The 25 MHz clock is not dependent on the state of the RESETn pin.

6.2 Reset and Configuration

RESETn should be asserted as shown in [Section 7.5.3](#). At the de-assertion of RESETn, hardware configuration values are latched into the device as described in [Section 3.3](#).

7 Electrical Specifications

7.1 Absolute Maximum Ratings

Table 60: Absolute Maximum Ratings

Stresses above those listed in Absolute Maximum Ratings may cause permanent device failure. Functionality at or above these limits is not implied. Exposure to absolute maximum ratings for extended periods may affect device reliability.

Symbol	Parameter	Min	Max	Units
V _{DDAL}	Power Supply Voltage on AVDDL with respect to VSS	-0.5	1.5	V
V _{DDAH}	Power Supply Voltage on AVDDH with respect to VSS	-0.5	1.5	V
V _{DDAC}	Power Supply Voltage on AVDDC with respect to VSS	-0.5	1.5	V
V _{DDAT}	Power Supply Voltage on AVDDT with respect to VSS	-0.5	3.6	V
V _{DDON}	Power Supply Voltage on VDDON with respect to VSS	-0.5	3.6	V
V _{DDOS}	Power Supply Voltage on VDDOS with respect to VSS	-0.5	3.6	V
V _{DD}	Power Supply Voltage on DVDD with respect to VSS	-0.5	1.5	V
T _{STORAGE}	Storage temperature	-40	+125 ¹	°C

1. 125°C is only used as bake temperature for not more than 24 hours. Long-term storage (for example, weeks or longer) should be kept at 85°C or lower.

7.2 Recommended Operating Conditions

Table 61: Recommended Operating Conditions (Commercial)

Symbol	Parameter	Condition	Min	Typ	Max	Units
V _{DDAL} ¹	AVDDL Supply	For AVDDL	0.95	1.0	1.05	V
V _{DDAH}	AVDDH Supply	For AVDDH	0.95	1.0	1.05	V
V _{DDAC}	AVDDC Supply	For AVDDC	0.95	1.0	1.05	V
V _{DDAT}	AVDDT Supply	3.3V	3.135	3.3	3.465	V
		2.5V	2.375	2.5	2.625	
V _{VDDO}	VDDON or VDDOS Supply	3.3V	3.135	3.3	3.465	V
		2.5V	2.375	2.5	2.625	
		1.8V	1.71	1.8	1.89	
		1.2V	1.14	1.2	1.26	
		1.05V	0.998	1.05	1.103	
V _{DD}	DVDD Supply (C Temp)	–	0.855	0.9	0.945	V
V _{DD}	DVDD Supply (I Temp)	–	0.902	0.95	0.997	V
T _J	Maximum junction temperature	–	–	–	105 ²	°C

1. Maximum noise allowed on supplies is 5 mVppd.
2. Refer to the white paper on T_J Thermal Calculations for detailed information.

7.3 Package Thermal Information

7.3.1 Thermal Conditions for 169-pin, FCBGA Package

Table 62: Thermal Conditions for 169-pin, FCBGA Package

Symbol	Parameter	Condition	Min	Typ	Max	Units
θ_{JA}	Thermal resistance ¹ - junction to ambient for the 169-pin FCBGA package $\theta_{JA} = (T_J - T_A)/P$ P = Total power dissipation	JEDEC 3 in. x 4.5 in. 12-layer PCB with no air flow	–	16.28	–	°C/W
		JEDEC 3 in. x 4.5 in. 12-layer PCB with 1 meter/sec air flow	–	14.00	–	°C/W
		JEDEC 3 in. x 4.5 in. 12-layer PCB with 2 meter/sec air flow	–	12.98	–	°C/W
		JEDEC 3 in. x 4.5 in. 12-layer PCB with 3 meter/sec air flow	–	12.36	–	°C/W
Ψ_{JT}	Thermal characteristic parameter ^a - junction to top center of the 169-pin FCBGA package $\Psi_{JT} = (T_J - T_{top})/P$ P = Total power dissipation, T_{top} : Temperature on the top center of the package	JEDEC 3 in. x 4.5 in. 12-layer PCB with no air flow	–	1.30	–	°C/W
		JEDEC 3 in. x 4.5 in. 12-layer PCB with 1 meter/sec air flow	–	1.31	–	°C/W
		JEDEC 3 in. x 4.5 in. 12-layer PCB with 2 meter/sec air flow	–	1.32	–	°C/W
		JEDEC 3 in. x 4.5 in. 12-layer PCB with 3 meter/sec air flow	–	1.33	–	°C/W
θ_{JC}	Thermal resistance ^a - junction to case for the 169-pin FCBGA package $\theta_{JC} = (T_J - T_C)/P_{top}$ P_{top} = Power dissipation from the top of the package	JEDEC with no air flow	–	1.70	–	°C/W
θ_{JB}	Thermal resistance ^a - junction to board for the 169-pin FCBGA package $\theta_{JB} = (T_J - T_B)/P_{bottom}$ P_{bottom} = Power dissipation from the bottom of the package to the PCB surface	JEDEC with no air flow	–	5.81	–	°C/W

1. Refer to the white paper on T_J Thermal Calculations for detailed information.

7.4 Current Consumption

7.4.1 88X5113 Current Consumption (Commercial)

Table 63: DVDD Current Consumption

Pins	Parameter	Condition	Min	Typ	Max	Units
DVDD	Base	Chip Base Power including leakage	–	84	941	mA
	1G PCS (1 lane power)	P1X, P1S, P1P	–	6	8	mA
	2.5G PCS (1 lane power)	P2.5X	–	13	16	mA
	5G PCS (1 lane power)	P5L, P5K	–	13	13	mA
	10G PCS - No FEC (1 lane power)	P10LN, P10KN	–	26	29	mA
	10G PCS - KR FEC (1 lane power)	P10KF, P10LF	–	31	37	mA
	25G PCS - No FEC (1 lane power)	P25LN, P25LR, P25CN, P25KN, P25BN, P25JN	–	54	60	mA
	25G PCS - KR FEC (1 lane power)	P25LF, P25CF, P25KF, P25BF, P25JF	–	67	76	mA
	25G PCS - RS FEC (1 lane power)	P25LR, P25CR, P25KR, P25BR, P25JR	–	99	111	mA
	40G PCS - No FEC (4 lane power)	P40LN, P40CN, P40KN	–	97	109	mA
	40G PCS - KR FEC (4 lane power)	P40CF, P40KL, P40LF	–	119	135	mA
	50G PCS - No FEC (4 lane power)	P50LN, P50CN, P50KN	–	110	124	mA
	50G PCS - KR FEC (4 lane power)	P50CF, P50KF, P50LF	–	139	160	mA
	50G PCS - No FEC (2 lane power)	P50MN, P50BN, P50JN	–	107	122	mA
	50G PCS - KR FEC (2 lane power)	P50MF, P50BF, P50JF	–	120	135	mA
	50G PCS - RS FEC (2 lane power)	P50MR, P50BR, P50JR	–	221	231	mA
	100G PCS - No FEC (4 lane power)	P100LN, P100KN	–	228	263	mA
	100G PCS - RS FEC (4 lane power)	P100LR, P100CR, P100KR	–	430	481	mA

Example: P100LN to P100CR operation

Current consumption on DVDD = DVDD Base + P100LN + P100CR

Table 64: AVDDL and AVDDH Current Consumption

Pins	Parameter	Condition	Min	Typ	Max	Units
AVDDL or AVDDH	Base	Chip Base Power including leakage	–	54	350	mA
	1G Speed (1 lane power)	P1*, R1	–	74	90	mA
	2.5G Spkvban641eed (1 lane power)	P2.5X, R2.5	–	89	111	mA
	5G Speed (1 lane power)	P5*, R5*	–	106	125	mA
	10G Speed (1 lane power)	P10*, R10*	–	144	164	mA
	25G Speed (1 lane power)	P25*, R25*	–	256	292	mA
	40G Speed (4 lane power)	P40*, R40*	–	567	653	mA
	50G Speed (4 lane power)	P50L*, P50C*, P50K*	–	641	739	mA
	50G Speed (2 lane power)	P50M*, P50B*, P50J*	–	509	583	mA
	100G Speed (4 lane power)	P100*, R100*	–	1003	1156	mA

Example: P100LN to P100CR operation

Current consumption on AVDD = AVDDL Base + AVDDH Base + P100* + P100* + AVDDC

Table 65: AVDDC and AVDDT Current Consumption

Pins	Parameter	Condition	Min	Typ	Max	Units
AVDDC	Base	Chip Base Power including leakage	–	–	10	mA
AVDDT	Base	Chip Base Power including leakage	–	–	34	mA

7.4.2 88X5113 Current Consumption (Industrial)

Table 66: DVDD Current Consumption

Pins	Parameter	Condition	Min	Typ	Max	Units
DVDD	Base	Chip Base Power including leakage	–	84	941	mA
	1G PCS (1 lane power)	P1X, P1S, P1P	–	6	8	mA
	2.5G PCS (1 lane power)	P2.5X	–	13	16	mA
	5G PCS (1 lane power)	P5L, P5K	–	13	13	mA
	10G PCS - No FEC (1 lane power)	P10LN, P10KN	–	26	29	mA
	10G PCS - KR FEC (1 lane power)	P10KF, P10LF	–	31	37	mA
	25G PCS - No FEC (1 lane power)	P25LN, P25LR, P25CN, P25KN, P25BN, P25JN	–	54	60	mA
	25G PCS - KR FEC (1 lane power)	P25LF, P25CF, P25KF, P25BF, P25JF	–	67	76	mA
	25G PCS - RS FEC (1 lane power)	P25LR, P25CR, P25KR, P25BR, P25JR	–	99	111	mA
	40G PCS - No FEC (4 lane power)	P40LN, P40CN, P40KN	–	97	109	mA
	40G PCS - KR FEC (4 lane power)	P40CF, P40KL, P40LF	–	119	135	mA
	50G PCS - No FEC (4 lane power)	P50LN, P50CN, P50KN	–	110	124	mA
	50G PCS - KR FEC (4 lane power)	P50CF, P50KF, P50LF	–	139	160	mA
	50G PCS - No FEC (2 lane power)	P50MN, P50BN, P50JN	–	107	122	mA
	50G PCS - KR FEC (2 lane power)	P50MF, P50BF, P50JF	–	120	135	mA
	50G PCS - RS FEC (2 lane power)	P50MR, P50BR, P50JR	–	221	231	mA
	100G PCS - No FEC (4 lane power)	P100LN, P100KN	–	228	263	mA
	100G PCS - RS FEC (4 lane power)	P100LR, P100CR, P100KR	–	430	481	mA

Example: P100LN to P100CR operation

Current consumption on DVDD = DVDD Base + P100LN + P100CR

Table 67: AVDDL and AVDDH Current Consumption

Pins	Parameter	Condition	Min	Typ	Max	Units
AVDDL or AVDDH	Base	Chip Base Power including leakage	–	54	350	mA
	1G Speed (1 lane power)	P1*, R1	–	74	90	mA
	2.5G Spkvban641eed (1 lane power)	P2.5X, R2.5	–	89	111	mA
	5G Speed (1 lane power)	P5*, R5*	–	106	125	mA
	10G Speed (1 lane power)	P10*, R10*	–	144	164	mA
	25G Speed (1 lane power)	P25*, R25*	–	256	292	mA
	40G Speed (4 lane power)	P40*, R40*	–	567	653	mA
	50G Speed (4 lane power)	P50L*, P50C*, P50K*	–	641	739	mA
	50G Speed (2 lane power)	P50M*, P50B*, P50J*	–	509	583	mA
	100G Speed (4 lane power)	P100*, R100*	–	1003	1156	mA

Example: P100LN to P100CR operation

Current consumption on AVDD = AVDDL Base + AVDDH Base + P100* + P100* + AVDDC

7.5 Digital I/O Electrical Specifications

Table 68: AVDDC and AVDDT Current Consumption

Pins	Parameter	Condition	Min	Typ	Max	Units
AVDDC	Base	Chip Base Power including leakage	–	–	10	mA
AVDDT	Base	Chip Base Power including leakage	–	–	34	mA

7.5.1 DC Operating Conditions

Table 69: DC Operating Conditions

(Over full range of values listed in the Recommended Operating Conditions unless otherwise specified)

Symbol	Parameter	Pins	Condition	Min	Typ	Max	Units
VIH	Input High Voltage	All digital inputs	VDDO* = 3.3V	2.0	–	VDDO + 0.3V	V
			VDDO* = 2.5V	1.75	–	VDDO + 0.3V	V
			VDDO* = 1.8V	1.26	–	VDDO + 0.3V	V
			VDDO* = 1.5V	1.05	–	VDDO + 0.3V	V
			VDDO* = 1.2V	0.84	–	VDDO + 0.3V	V
			VDDO* = 1.05V	0.74	–	VDDO + 0.3V	V
VIL	Input Low Voltage	All digital inputs	VDDO* = 3.3V	-0.3	–	0.8	V
			VDDO* = 2.5V	-0.3	–	0.75	V
			VDDO* = 1.8V	-0.3	–	0.54	V
			VDDO* = 1.5V	-0.3	–	0.45	V
			VDDO* = 1.2V	-0.3	–	0.36	V
			VDDO* = 1.05V	-0.3	–	0.31	V
VOH	High-level Output Voltage	All digital outputs	IOH = -4 mA	VDDO - 0.4V	–	–	V
VOL	Low-level Output Voltage	All digital outputs	IOL = 4 mA	–	–	0.4	V

Table 69: DC Operating Conditions

(Over full range of values listed in the Recommended Operating Conditions unless otherwise specified)

Symbol	Parameter	Pins	Condition	Min	Typ	Max	Units
I _{ILK}	Input Leakage Current	With internal pull-up/pull-down resistor	–	10	–	70	μA
		All others without resistor	–	–	–	10	μA
CIN	Input Capacitance	All pins	–	–	–	5	pF

7.5.2 AC Operating Conditions

Table 70: AC Operating Conditions

(Over Full range of values listed in the Recommended Operating Conditions unless otherwise specified)

Symbol	Parameter	Pins	Condition	Min	Typ	Max	Units
T _R	Rise Time	GPIO[0]	20 to 80% of V _{ppd}	–	0.87	–	ns
T _F	Fall Time	GPIO[0]	20 to 80% of V _{ppd}	–	0.68	–	ns

7.5.3 Reset Timing

Table 71: Reset Timing

(Over Full range of values listed in the Recommended Operating Conditions unless otherwise specified)

Symbol	Parameter	Condition	Min	Typ	Max	Units
T _{PU_RESET}	Valid Power to RESET De-asserted	–	10	–	–	ms
T _{SU_CLK}	Number of Valid CLK Cycles Prior to RESET De-asserted	–	50	–	–	clks
T _{RESET}	Minimum Reset Pulse Width During Normal Operation	–	10	–	–	ms

Figure 32: Reset Timing

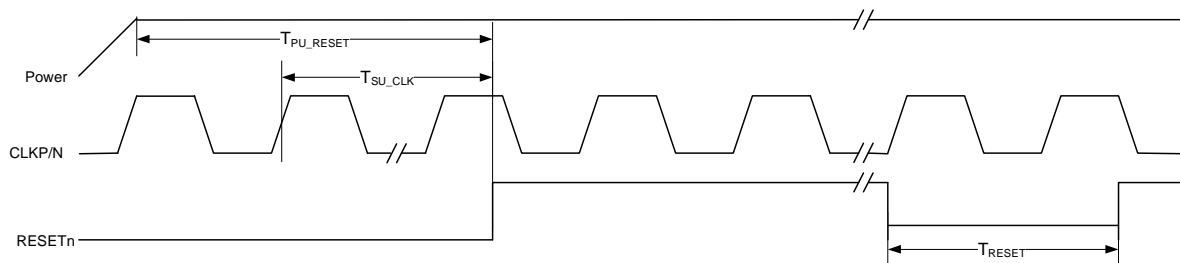

7.5.4 MDC/MDIO Management Interface Timing

Table 72: MDC/MDIO Management Interface Timing

(Over full range of values listed in the Recommended Operating Conditions unless otherwise specified)

Symbol	Parameter	Condition	Min	Typ	Max	Units
T_{DLY_MDIO}	MDC to MDIO (Output) Delay Time	25 pf load on MDIO	3.5	–	19	ns
T_{SU_MDIO}	MDIO (Input) to MDC Setup Time	–	6.5	–	–	ns
T_{HD_MDIO}	MDIO (Input) to MDC Hold Time	–	0.5	–	–	ns
T_{P_MDC}	MDC Period	Subject to T_{READ_DLY}	40 ^{1, 2}	–	–	ns
T_{H_MDC}	MDC High	–	12	–	–	ns
T_{L_MDC}	MDC Low	–	12	–	–	ns
T_{READ_DLY}	Two MDC Period During Read Turnaround	–	80	–	–	ns

- T_{P_MDC} is minimum of 25 ns for 40 MHz MDC clock support with stretched TA, but 40 ns (25 MHz) with standard TA as per IEEE specification. MDC of 40 MHz is supported only with VDDO supply of 1.8V and above. For lower VDDO, MDC frequency of up to 25 MHz is supported.
- The maximum MDC frequency is dependent on the Reference Clock used (CLK1P/N). The T_{P_MDC} listed is based on 156.25 MHz reference clock.

Figure 33: MDC/MDIO Management Interface

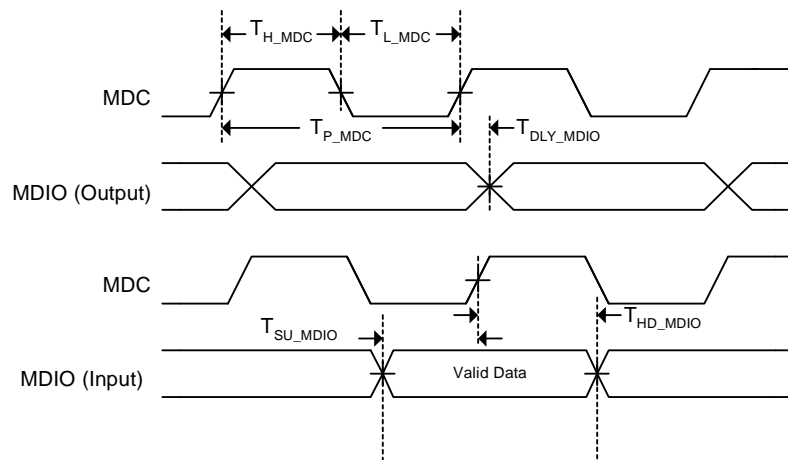

7.5.5 JTAG Timing

Table 73: JTAG Timing

(Over full range of values listed in the Recommended Operating Conditions unless otherwise specified)

Symbol	Parameter	Condition	Min	Typ	Max	Units
T_{P_TCK}	TCK Period	–	60	–	–	ns
T_{H_TCK}	TCK High	–	12	–	–	ns
T_{L_TCK}	TCK Low	–	12	–	–	ns
T_{SU_TDI}	TDI, TMS-to-TCK Setup Time	–	10	–	–	ns
T_{HD_TDI}	TDI, TMS-to-TCK Hold Time	–	10	–	–	ns
T_{DLY_TDO}	TCK-to-TDO Delay	–	0	–	15	ns

Figure 34: JTAG Timing

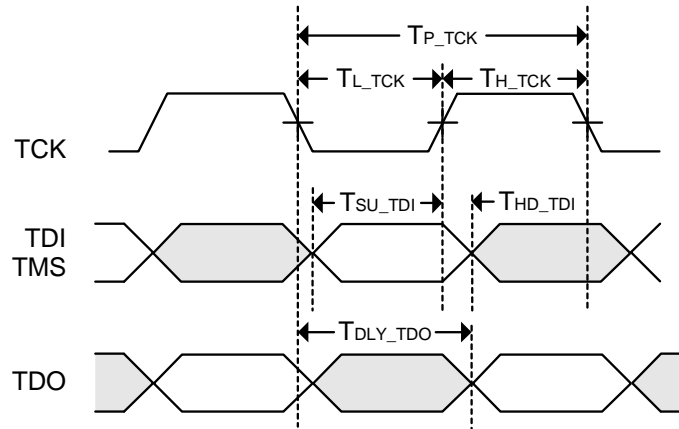

7.6 SERDES Electrical Specifications

7.6.1 Chip-to-Module 100 Gbps/25 Gbps Electrical Characteristics

7.6.1.1 Chip-to-Module 100 Gbps/25 Gbps Transmitter and Receiver Characteristics

Table 74: Chip-to-Module CAUI-4/XXVAUI-1 Transmitter and Receiver Characteristics

Symbol	Description	Min	Max	Units	Notes
BR	Baud rate	25.78125		Gbps	–
Bppm	Baud rate tolerance	-100	100	ppm	1
UI	Unit interval	38.787879		ps	–
Transmitter Parameters					
Vodis	Transmitter disabled output differential noise level	–	35	mV	–
Vodpp	Output differential maximum peak-to-peak	–	900	mV	–
Tr	Output transition time	10	–	ps	8
Vosdc	DC Common-mode voltage limits	-0.3	2.8	V	–
Vosac	AC Common-mode voltage limits (RMS)	–	17.5	mV	–
RLOD	Return loss differential output	–	–	dB	2, 4
RLOCD	Common to differential mode output return loss	See note #3.		dB	3, 4
Ehatx	Differential output eye height A	95	–	mV	10
Ehbtx	Differential output eye height B	80	–	mV	10
Ew tx	Differential output eye width	0.46	–	UI	5, 10
Receiver Parameters					
Vidpp	Input differential voltage	–	900	mV	7, 11
RLID	Return loss differential input	See note #2.		dB	2, 4
RLIDC	Differential to common mode input return loss	See note #3.		dB	3, 4
Ehrx	Receiver stress tolerance -eye height	228	–	mV	5, 6, 11
Ew rx	Receiver stress tolerance -eye width	0.57	–	UI	5, 6, 11



Note

The load is 100Ω differential for these parameters, unless otherwise specified. The Tx table is defined on TP1a and Rx table is defined on TP4a refer to 83E.2 CAUI-4 chip-to-module compliance point definitions in the IEEE 802.3 standard.

- Defines the allowable reference clock difference and Rx baud rate tolerance relative to nominal. Tx baud rate is derived from multiplication of the reference clock(0ppmdelta).
 - RLOD and RLID are defined accordingly: For 10 MHz -8 GHz RLOD/RLID>9.5-0.37*f [dB] (Frequency defined in GHz). For 8 GHz -19 GHz RLOD/RLID>4.75-7.4Log(f/14) [dB] (Frequency defined in GHz).
 - RLOCD and RLID Care defined accordingly: For 10 MHz -12.89 GHz RLOCD/RLIDC>22-(20/25.78)*f [dB] (Frequency defined in GHz). For 12.89 GHz -19 GHz RLOCD/RLIDC>15-(6/25.78)*f [dB] (Frequency defined in GHz).
 - Relative to 100Ω differential and 25Ω common mode.
 - Defined with a Bit Error Rate (BER) of 10⁻¹⁵.
 - Defined according to IEEE 802.3 section 83E.3.3.2 Host stressed input test.
 - Vidpp refers to the peak-to-peak.
 - Defined 20 to 80% of the signal. Refer to section 83E.3.1.5 Transition time in the IEEE 802.3 standard.
 - Refer to section 83E.3.1.4 Differential termination mismatch in IEEE 802.3 standard.
 - Refer to section 83E.3.1.6 Host output eye width and eye height in IEEE 802.3 standard.
- Defined on TP4 as defined in 83E.2 CAUI-4 chip-to-module compliance point definitions in IEEE 802.3 standard.

Table 75: Chip-to-Module CAUI-4/XXVAUI-1 Settings and Configuration

Parameter	Setting/Configuration
Vods	The Vods is the output differential amplitude configurable range. When driving a test load, the minimum value is achieved with AMP=TBD and PRE=TBD, and the maximum value is achieved with AMP=TBD and PRE=TBD. Output amplitude and pre-emphasis are configurable.
Viddp	The Viddp is the input differential voltage. The maximum single-ended voltage (common mode voltage and swing voltage) must not exceed 1.8V.
Vodpp	To achieve the specifications at Tp1a, the use of emphasis may be needed.
Output Equalization	For emphasis control information, refer to the Functional Specifications.
NOTE: For further information, refer to the Functional Specifications.	

7.6.1.2 Chip-to-Module CAUI-4/XXVAUI-1 Interface Transmitter Output Voltage Limits and Definitions

Figure 35: Chip-to-Module CAUI-4/XXVAUI-1 Interface Transmitter Output Voltage Limits and Definitions

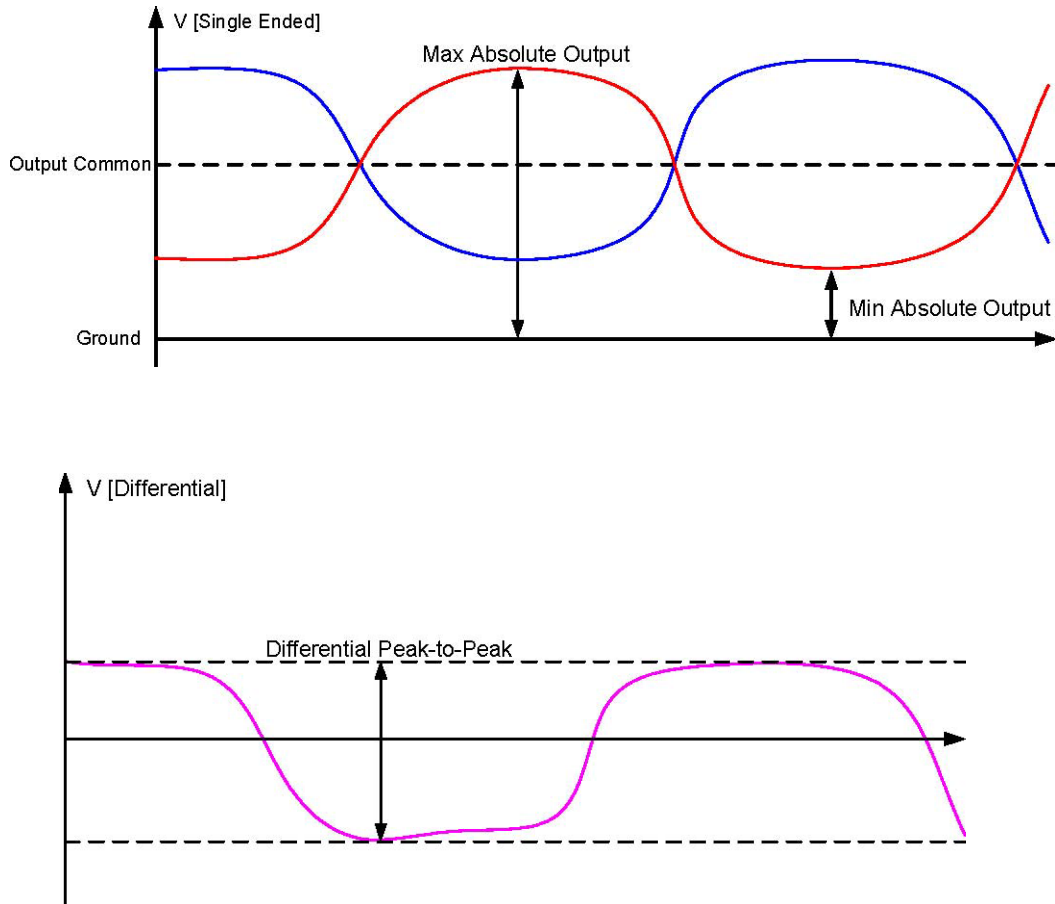
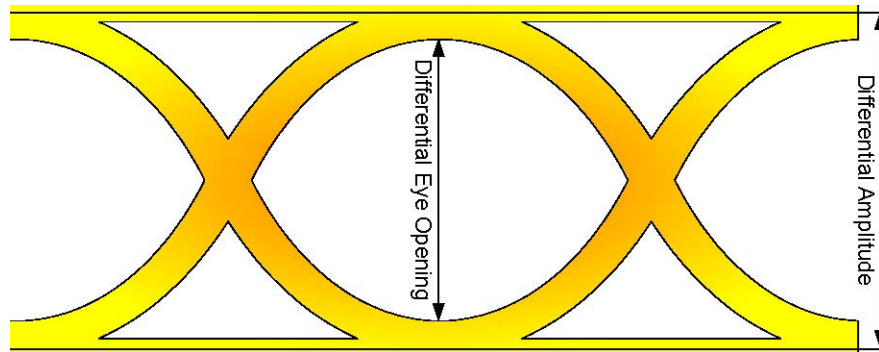

Figure 36: Chip-to-Module CAUI-4/XXVAUI-1 Transmitter Output Differential Amplitude and Eye Opening



7.6.2 Chip-to-Chip 100 Gbps/25 Gbps (CAUI-4/XXVAUI-1) Electrical Characteristics

7.6.2.1 Chip-to-Chip 100 Gbps/25 Gbps (CAUI-4/XXVAUI-1) Transmitter and Receiver Characteristics

Table 76: Chip-to-Chip Gbps CAUI-4/XXVAUI-1 Interface Transmitter and Receiver Characteristics

Symbol	Description	Min	Max	Units	Notes
BR	Baud rate	25.78125		Gbps	–
Bppm	Baud rate tolerance	-100	100	ppm	1
UI	Unit interval	38.787879		ps	–
Transmitter Parameters					
Vodis	Transmitter disabled output differential noise level	–	30	mV	–
Vodpp	Output differential maximum peak-to-peak	–	1200	mV	–
Vf	Output waveform -Steady-state voltage	0.4	0.6	V	12
Vlfpp	Output waveform -Linear fit pulse peak	0.71*Vf	–	V	12
Prec	Output waveform -Pre-cursor full-scale range	See note #13.		–	13
Pstc	Output waveform - Post-cursor full-scale range	See note #13.		–	13
Vsnr	Transmitter signal-to-noise-and-distortion ratio	27	–	dB	14
Vosdc	DC Common-mode voltage limits	0.0	1.9	V	–
Vosac	AC Common-mode voltage limits (RMS)	–	12	mV	–
RLOD	Return loss differential output	See note #2.		dB	2, 5
RLOC	Return loss Common-Mode output	See note #3.		dB	3, 5
Juctx	Output jitter -Effective bounded uncorrelated, peak-to-peak	–	0.1	UI	10
Jeotx	Output Even-Odd jitter	–	0.035	UI	11
Jtpptx	Output jitter -Effective total uncorrelated, peak-to-peak	–	0.26	UI	6, 9, 10
Receiver Parameters					
Vidpp	Input differential voltage	–	1200	mV	8
RLID	Return loss differential input	See note #2.		dB	2, 5
RLIDC	Differential to common mode input return loss	See note #4.		dB	4, 5
Rit	Receiver interference tolerance	See note #7.		UI	7



Note

The load is 100Ω differential for these parameters, unless otherwise specified. General Comment: The Tx table is defined on TP0a as defined in 93.8.1.1 Transmitter test fixture in IEEE 802.3 standard. General Comment: The Rx table is defined on TP5a as defined in 93.8.2.1 Receiver test fixture in 802.3 IEEE standard.

- Defines the allowable reference clock difference and Rx baud rate tolerance relative to nominal. Tx baud rate is derived from multiplication of the reference clock (0 ppm delta).
- RLOD and RLID are defined accordingly: For 50 MHz - 6 GHz RLOD/RLID>12.05-f [dB] (Frequency defined in GHz). For 6 GHz -19 GHz RLOD/RLID>6.5-0.075*f [dB] (Frequency defined in GHz).
- RLOC is defined accordingly: For 50 MHz -6 GHz RLOC>9.05-f [dB] (Frequency defined in GHz). For 6 GHz -19 GHz RLOC>3.5-0.075*f [dB] (Frequency defined in GHz).
- RLIDC is defined accordingly: For 50 MHz -6.95 GHz RLIDC>25-1.44*f [dB] (Frequency defined in GHz). For 6.95 GHz -19 GHz RLIDC>15 [dB].
- Relative to 100Ω differential and 25Ω common mode.
- Defined with a Bit Error Rate (BER) of 10⁻¹⁵.
- Defined according to IEEE 802.3 section 83D.3.3.1 Receiver interference tolerance.
- Vidpp refers to the peak-to-peak.
- The output Tx jitter is defined when applying the effect of a single-pole high-pass filter on the jitter. The high-pass filter 3 dB point is located at 10 MHz.
- The transmitter output waveform follows IEEE requirements as specified in section 92.8.3.8.2 Effective bounded uncorrelated jitter and effective random jitter, (except that the range for fitting CDFLi and CDFRi will be from 10⁻⁶ to 10⁻⁴).
- Defined for a PRBS9 pattern according to section 92.8.3.8.1 Even-odd jitter in 802.3 IEEE standard.
- The transmitter output waveform follows IEEE requirements as specified in section 93.8.1.5.2 Steady-state voltage and linear fit pulse peak, (except that the values of Np and Nw are 5).
- The transmitter output waveform follows IEEE requirements as specified in section 83D.3.1.1 Transmitter equalization settings.
- The transmitter output waveform follows IEEE requirements as specified in section 93.8.1.6 Transmitter output noise and distortion (except that the values of Np and Nw are 5).

Table 77: Chip-to-Chip CAUI-4/XXVAUI-1 Settings and Configuration

Parameter	Setting/Configuration
Vods	The Vods is the output differential amplitude configurable range. When driving a test load, the minimum value is achieved with AMP=TBD and PRE=TBD, and the maximum value is achieved with AMP=TBD and PRE=TBD. Output amplitude and pre-emphasis are configurable.
Viddp	The Viddp is the input differential voltage. The maximum single-ended voltage (common mode voltage and swing voltage) must not exceed 1.8V.
Vodpp	To achieve the specifications at Tp1a, the use of emphasis may be required.

Table 77: Chip-to-Chip CAUI-4/XXVAUI-1 Settings and Configuration (Continued)

Parameter	Setting/Configuration
Output Equalization	For emphasis control information, refer to the Functional Specifications.
NOTE: For further information, refer to the Functional Specifications.	

7.6.2.2 Chip-to-Chip CAUI-4/XXVAUI-1 Interface Transmitter Output Voltage Limits and Definitions

Figure 37: Chip-to-Chip CAUI-4/XXVAUI-1 Interface Transmitter Output Voltage Limits and Definitions

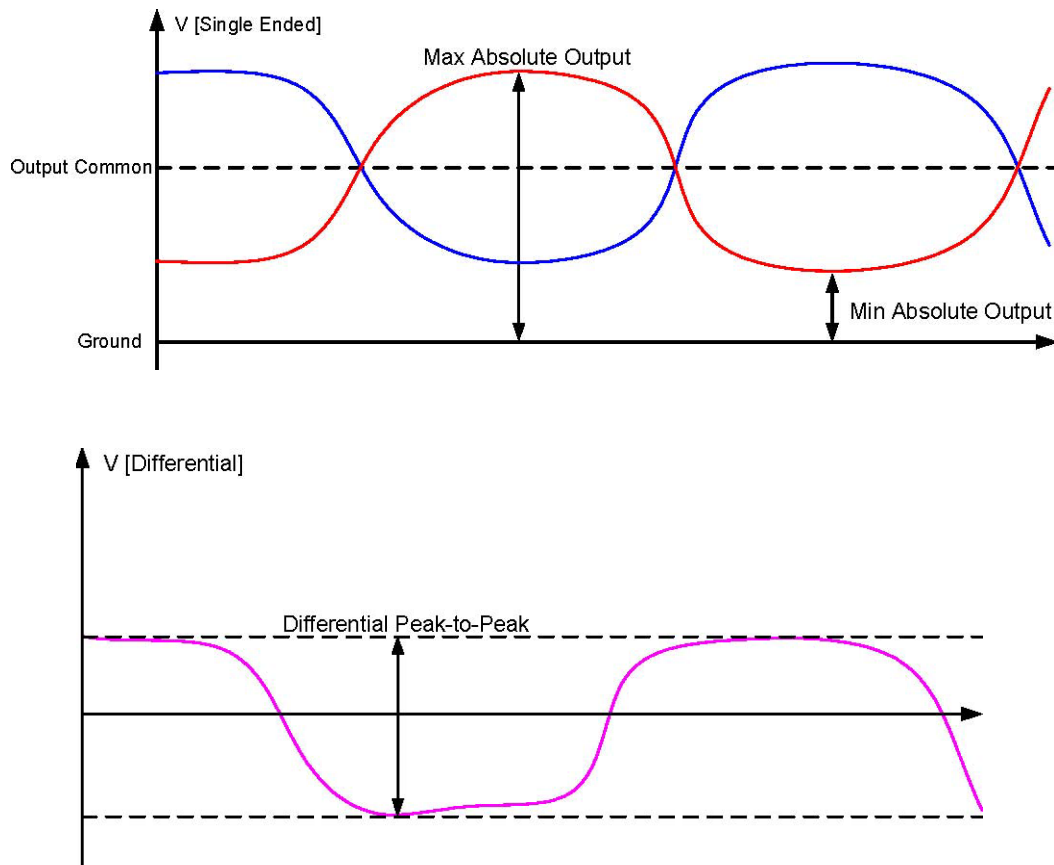
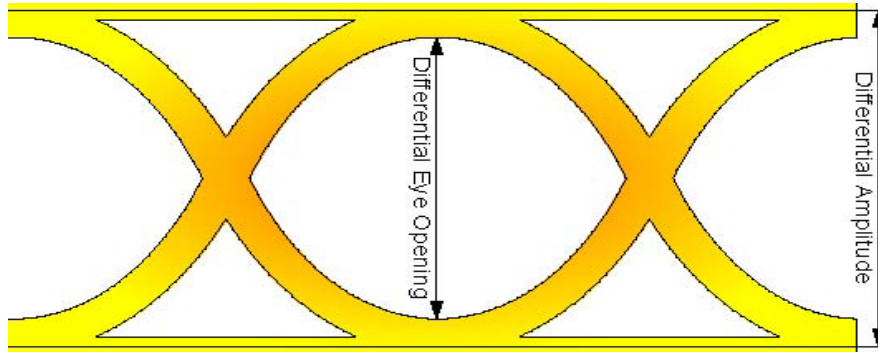

Figure 38: Chip-to-Chip CAUI-4/XXVAUI-1 Transmitter Output Differential Amplitude and Eye Opening



7.6.3 100GBASE-CR4/50GBASE-CR2/25GBASE-CR Electrical Characteristics

7.6.3.1 100GBASE-CR4/50GBASE-CR2/25GBASE-CR Interface Transmitter and Receiver Characteristics

Table 78: 100GBASE-CR4/50GBASE-CR2/25GBASE-CR Interface Transmitter and Receiver Characteristics

Symbol	Parameter	Min	Max	Units	Notes
BR	Baud rate	25.78125		Gbps	–
Bppm	Baud rate tolerance	-100	100	ppm	1
UI	Unit interval	38.787879		ps	–
Transmitter Parameters					
Vodis	Transmitter disabled output differential noise level	–	35	mV	–
Vodpp	Output differential maximum peak-to-peak	–	1200	mV	–
Vf	Output waveform - Steady-state voltage	0.34	0.6	V	12
Vlfpp	Output waveform -Linear fit pulse peak	0.45*Vf	–	V	12
Ncs	Output waveform - Normalized coefficient step size	0.0083	0.05	–	13
Prec	Output waveform - Pre-cursor full-scale range	1.54	–	–	14
Pstc	Output waveform - Post-cursor full-scale range	4	–	–	14
Vsnr	Transmitter signal-to-noise-and-distortion ratio	26	–	dB	15
Vosdc	DC Common-mode voltage limits	0.0	1.9	V	–
Vosac	AC Common-mode voltage limits (RMS)	–	30	mV	–
RLOD	Return loss differential output	See note #2.		dB	2, 5
RLOCD	Return loss Common-Mode to Differential output	See note #3.		dB	3, 5
RLOC	Return loss Common-Mode output	2	–	dB	5, 16
Juctx	Output jitter -Effective bounded uncorrelated, peak-to-peak	–	0.1	UI	17
Jeotx	Output Even-Odd jitter	–	0.035	UI	11
Jtpptx	Output jitter - Effective total uncorrelated, peak-to-peak	–	0.18	UI	6, 9, 17
Receiver Parameters					
Vidpp	Input differential voltage	–	1200	mV	8
RLID	Return loss differential input	See note #2.		dB	2, 5
RLIDC	Differential to common mode input return loss	See note #4.		dB	4, 5

Table 78: 100GBASE-CR4/50GBASE-CR2/25GBASE-CR Interface Transmitter and Receiver Characteristics (Continued)

Symbol	Parameter	Min	Max	Units	Notes
Rit	Receiver interference tolerance	See note #7.		UI	7
Rjt	Receiver jitter tolerance	See note #10.		UI	6, 10



Note

The load is 100Ω differential for these parameters, unless otherwise specified. General Comment: The Tx table is defined on TP2 as defined in 92.11 Test fixtures in 802.3 IEEE standard. General Comment: The Rx table is defined on TP3 as defined in 92.11 Test fixtures in 802.3 IEEE standard.

- Defines the allowable reference clock difference and Rx baud rate tolerance relative to nominal. Tx baud rate is derived from multiplication of the reference clock (0 ppm delta).
- RLOD and RLID are defined accordingly: For 10 MHz -8 GHz RLOD/RLID > 9.5 - 0.37*f [dB] (Frequency defined in GHz). For 8 GHz -19 GHz RLOD/RLID > 4.75 - 7.4*Log(f/14) [dB] (Frequency defined in GHz).
- RLOCD and RLIDC are defined accordingly: For 10 MHz -12.89 GHz RLOCD/RLIDC > 22 - (20/25.78)*f [dB] (Frequency defined in GHz). For 12.89 GHz -19 GHz RLOCD/RLIDC > 15 - (6/25.78)*f [dB] (Frequency defined in GHz).
- Relative to 100Ω differential and 25Ω common mode.
- Defined with a Bit Error Rate (BER) of 10⁻⁵.
- Defined according to IEEE 802.3 section 92.8.4.4 Receiver interference tolerance test.
- Vidpp refers to the peak-to-peak. Defined according to IEEE 802.3 section 92.8.4.1 Receiver input amplitude tolerance.
- The output Tx jitter is defined when applying the effect of a single-pole high-pass filter on the jitter. The high-pass filter 3 dB point is located at 10 MHz.
- Defined according to IEEE 802.3 section 92.8.4.5 Receiver jitter tolerance.
- Defined for a PRBS9 pattern according to section 92.8.3.8.1 Even-odd jitter in 802.3 IEEE standard.
- The transmitter output waveform follows IEEE requirements as specified in section 92.8.3.5.2 Steady-state voltage and linear fit pulse peak.
- The transmitter output waveform follows IEEE requirements as specified in section 92.8.3.5.4 Coefficient step size.
- The transmitter output waveform follows IEEE requirements as specified in section 92.8.3.5.5 Coefficient range.
- The transmitter output waveform follows IEEE requirements as specified in section 92.8.3.7 Transmitter output noise and distortion.
- Defined from 200 MHz to 19 GHz.
- The transmitter jitter follows IEEE requirements as specified in section 92.8.3.8.2 Effective bounded uncorrelated jitter and effective random jitter.

Table 79: 100GBASE-CR4/50GBASE-CR2/25GBASE-CR Settings and Configuration

Parameter	Setting/Configuration
Vods	The Vods is the output differential amplitude configurable range. When driving a test load, the minimum value is achieved with AMP=TBD and PRE=TBD, and the maximum value is achieved with AMP=TBD and PRE=TBD. Output amplitude and pre-emphasis are configurable.
Viddp	The Viddp is the input differential voltage. The maximum single-ended voltage (common mode voltage and swing voltage) must not exceed 1.8V.
Vodpp	To achieve the specifications at Tp1a, the use of emphasis may be needed.
Output Equalization	For emphasis control information, refer to the Functional Specifications.
NOTE: For further information, refer to the Functional Specifications.	

7.6.3.2 100GBASE-CR4/50GBASE-CR2/25GBASE-CR Interface Transmitter Output Voltage Limits and Definitions

Figure 39: 100GBASE-CR4/50GBASE-CR2/25GBASE-CR Interface Transmitter Output Voltage Limits and Definitions

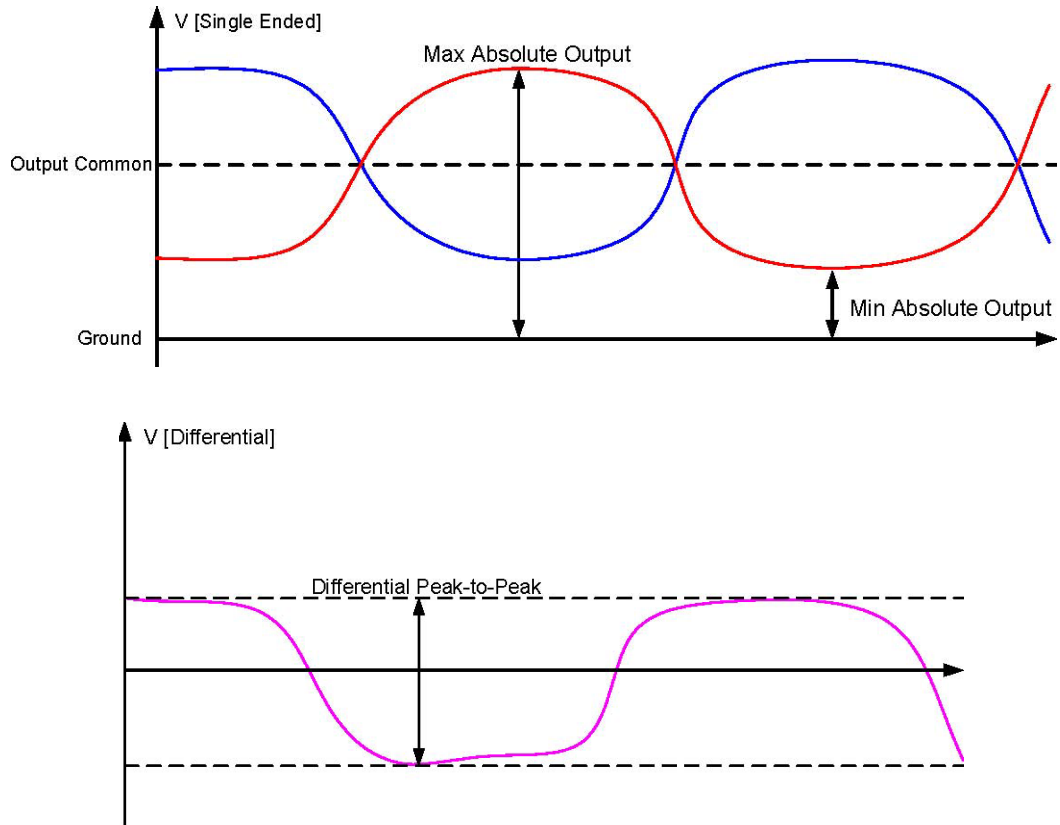

7.6.4 100GBASE-KR4/50GBASE-KR2/25GBASE-KR Electrical Characteristics

7.6.4.1 100GBASE-KR4/50GBASE-KR2/25GBASE-KR Interface Transmitter and Receiver Characteristics

Table 80: 100GBASE-KR4/50GBASE-KR2/25GBASE-KR Interface Transmitter and Receiver Characteristics

Symbol	Parameter	Min	Max	Units	Notes
BR	Baud rate	25.78125		Gbps	–
Bppm	Baud rate tolerance	-100	100	ppm	1
UI	Unit interval	38.787879		ps	–
Transmitter Parameters					
Vodis	Transmitter disabled output differential noise level	–	30	mV	–
Vodpp	Output differential maximum peak-to-peak	–	1200	mV	–
Vf	Output waveform - Steady-state voltage	0.4	0.6	V	12
Vlfp	Output waveform -Linear fit pulse peak	0.71*Vf	–	V	12
Ncs	Output waveform - Normalized coefficient step size	0.0083	0.05	–	13
Prec	Output waveform - Pre-cursor full-scale range	1.54	–	–	14
Pstc	Output waveform - Post-cursor full-scale range	4	–	–	14
Vsnr	Transmitter signal-to-noise-and-distortion ratio	27	–	dB	15
Vosdc	DC Common-mode voltage limits	0.0	1.9	V	–
Vosac	AC Common-mode voltage limits (RMS)	–	12	mV	–
RLOD	Return loss differential output	See note #2.		dB	2, 5
RLOC	Return loss Common-Mode output	See note #3.		dB	5, 16
Juctx	Output jitter - Effective bounded uncorrelated, peak-to-peak	–	0.1	UI	17
Jeotx	Output Even-Odd jitter	–	0.035	UI	11
Jtpptx	Output jitter - Effective total uncorrelated, peak-to-peak	–	0.18	UI	6, 9, 17
Receiver Parameters					
Vidpp	Input differential voltage	–	1200	mV	8
RLID	Return loss differential input	See note #2.		dB	2, 5
RLIDC	Differential to common mode input return loss	See note #4.		dB	4, 5

Table 80: 100GBASE-KR4/50GBASE-KR2/25GBASE-KR Interface Transmitter and Receiver Characteristics (Continued)

Symbol	Parameter	Min	Max	Units	Notes
Rit	Receiver interference tolerance	See note #7.		UI	7
Rjt	Receiver jitter tolerance	See note #10.		UI	6, 10



Note

The load is 100Ω differential for these parameters, unless otherwise specified. General Comment: The Tx table is defined on TP0a as defined in 93.8.1.1 Transmitter test fixture in the IEEE 802.3 standard. General Comment: The Rx table is defined on TP5a as defined in 93.8.2.1 Receiver test Micmac in the IEEE 802.3 standard.

- Defines the allowable reference clock difference and Rx baud rate tolerance relative to nominal. Tx baud rate is derived from multiplication of the reference clock (0 ppm delta).
- RLOD and RLID are defined accordingly: For 50 MHz -6 GHz RLOD/RLID>12.05-f [Frequency] (Frequency defined in GHz). For 6 GHz -19 GHz RLOD/RLID>6.5-0.075*f [dB] (Frequency defined in GHz).
- RLOC is defined accordingly: For 50 MHz -6 GHz RLOC>9.05-f [dB] (Frequency defined in GHz). For 6 GHz -19 GHz RLOC>3.5-0.075*f [dB] (Frequency defined in GHz).
- RLIDC is defined accordingly: For 50 MHz -6.95 GHz RLIDC>25-1.44*f [dB] (Frequency defined in GHz). For 6.95 GHz -19 GHz RLIDC>15 [dB].
- Relative to 100Ω differential and 25Ω common mode.
- Defined with a Bit Error Rate (BER) of 10⁻⁵.
- Defined according to IEEE 802.3 section 93.8.2.3 Receiver interference tolerance.
- Vidpp refers to the peak-to-peak.
- The output Tx jitter is defined when applying the effect of a single-pole high-pass filter on the jitter. The high-pass filter 3 dB point is located at 10 MHz.
- Defined according to IEEE 802.3 section 93.8.2.4 Receiver jitter tolerance
- Defined for a PRBS9 pattern according to section 92.8.3.8.1 Even-odd jitter in the IEEE 802.3 standard.
- The transmitter output waveform follows IEEE requirements as specified in section 93.8.1.5.2 Steady-state voltage and linear fit pulse peak.
- The transmitter output waveform follows IEEE requirements as specified in section 93.8.1.5.4 Coefficient step size.
- The transmitter output waveform follows IEEE requirements as specified in section 93.8.1.5.5 Coefficient range.
- The transmitter output waveform follows IEEE requirements as specified in section 93.8.1.6 Transmitter output noise and distortion.
- The transmitter output jitter follows IEEE requirements as specified.

Table 81: 100GBASE-KR4/50GBASE-KR2/25GBASE-KR Settings and Configuration

Parameter	Setting/Configuration
Vods	The Vods is the output differential amplitude configurable range. When driving a test load, the minimum value is achieved with AMP=TBD and PRE=TBD, and the maximum value is achieved with AMP=TBD and PRE=TBD. Output amplitude and pre-emphasis are configurable.
Viddp	The Viddp is the input differential voltage. The maximum single-ended voltage (common mode voltage and swing voltage) must not exceed 1.8V.
Vodpp	To achieve the specifications at Tp1a, the use of emphasis may be needed.
Output Equalization	For emphasis control information, refer to the Functional Specifications.
NOTE: For further information, refer to the Functional Specifications.	

7.6.4.2 100GBASE-KR4/50GBASE-KR2/25GBASE-KR Interface Transmitter Output Voltage Limits and Definitions

Figure 40: 100GBASE-KR4/50GBASE-KR2/25GBASE-KR Interface Transmitter Output Voltage Limits and Definitions

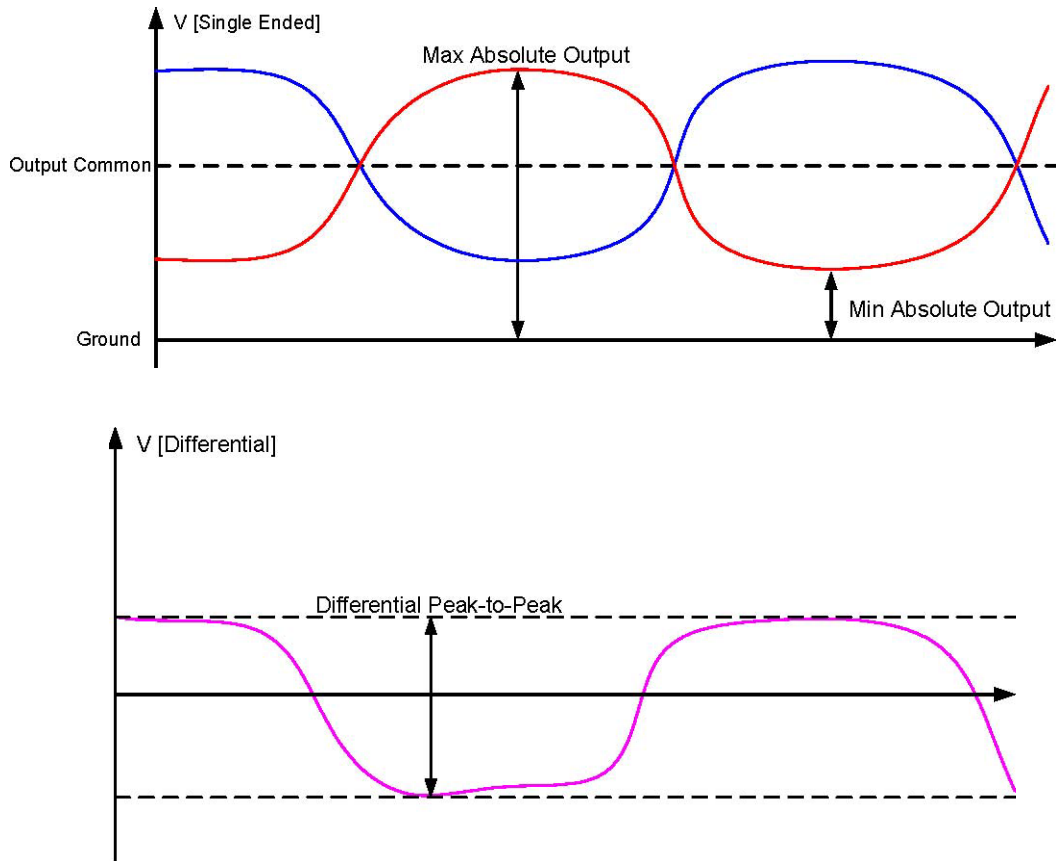

7.6.5 40 Gbps Parallel Physical Interface (XLPPI) Electrical Characteristics

7.6.5.1 40 Gbps Parallel Physical Interface (XLPPI) Interface Transmitter and Receiver Characteristics

Table 82: XLPPI Interface Transmitter and Receiver Characteristics

Symbol	Parameter	Min	Max	Units	Notes
BR	Baud rate	10.3125		Gbps	–
Bppm	Baud rate tolerance	-100	100	ppm	1
UI	Unit interval	96.969697		ps	–
Transmitter Parameters					
Vodpp	Output differential maximum peak-to-peak	190	700	mV	–
Vos	Single-ended output voltage	-0.3	1.9	V	11
Q _{SQ}	Signal-to-noise-ratio	45	–	V/V	14
Tr/Tf	Output differential transition time	28	–	ps	2, 11
RLOD	Return loss differential output	See note #3.			3, 4, 11
RLOC	Return loss common mode output	See note #3.			3, 4, 11
Tiskew	Output lane-to-lane skew	–	29	ns	–
Tiskew v	Output lane-to-lane skew variation	–	200	ps	–
dZM	Termination mismatch	–	5	%	9, 11
Vocmac	Output AC common mode voltage, RMS	–	15	mV	11, 12
Jddpw st	Output jitter - Data dependent pulse width shrinkage	–	0.07	UI	11
J2tx	Output 99% jitter - J2, peak-to-peak	–	0.17	UI	8, 11
J9tx	Output jitter - J9, peak-to-peak	–	0.29	UI	8, 11
Jtpptx	Output jitter - Total, peak-to-peak	–	0.22	UI	5, 8, 11
Receiver Parameters					
Vidpps	Input differential sensitivity	300	–	mV	5,7,11
Vidpp	Input differential voltage - 850 mV 5, 7, 11	–	850	mV	5,7,11
RLID	Return loss differential input	See note # 3.		dB	3, 4, 11
RLICD	Reflected input common mode to differential conversion	10	–	dB	10, 11
Rlskew	Input lane-to-lane skew	–	160	ns	–

Table 82: XLPPi Interface Transmitter and Receiver Characteristics (Continued)

Symbol	Parameter	Min	Max	Units	Notes
Rlskew v	Input lane-to-lane skew variation	–	4	ns	–
J2rx	Input 99% jitter - J2, peak-to-peak	–	0.42	UI	6, 11
J9rx	Input jitter - J9, peak-to-peak	–	0.65	UI	11
Jddpw sr	Input jitter - Data dependent pulse width shrinkage	–	0.34	UI	11, 13
Vicmac	Input AC common mode voltage, RMS	–	7.5	mV	11, 12



Note

The load is 100Ω differential for these parameters, unless otherwise specified. The reference points are according to Figure 86-2 in the IEEE Std 802.3-2010.

- Defines the allowable reference clock difference and Rx baud rate tolerance relative to nominal. Tx baud rate is derived from multiplication of the reference clock (zero ppm delta).
- Defined from 20 to 80% of the signal's voltage levels when driving a pattern consisting of eight consecutive ones followed by an equal run of zeros with no equalization. Maximum transition time is limited by mask as defined in IEEE 802.3 section 86A.5.3.6 Eye mask for TP1a and TP4.
- RLOD/RLID are defined from:
- 10.0 MHz to 4.11 GHz $RLOD/RLID > 12 - 2(\text{Frequency})^{0.5}$ [dB] (Frequency defined in GHz). For 4.11 GHz to 11.1 GHz $RLOD/RLID > 6.3 - 13\log(\text{Frequency}/5.5)$ [dB] (Frequency defined in GHz). RLOC is defined from:
- 10.0 MHz to 2.5 GHz $RLOC > 7 - 1.6 * (\text{Frequency})$ [dB] (Frequency defined in GHz). For 2.5 GHz to 11.1 GHz $RLOC > 3\text{dB}$.
- Relative to 100Ω differential and 25Ω common mode. Return loss includes contributions from on-chip circuitry, chip packaging, and off-chip optimized components related to the transmitter/receiver breakout.
- Defined with a Hit Ratio of $5 * 10^{-5}$.
- Defined with all but 1 percent of occurrences.
- Vidpps refers to the internal eye opening while Vidp prefers to the peak-to-peak.
- The output Tx jitter is defined when applying the effect of a single-pole high-pass filter on the-jitter. The high-pass filter 3 dB point is located at 4 MHz.
- Defined at 1 MHz frequency. Defined according to section 86A.5.3.2 Termination mismatch in the IEEE Std 802.3-2010.
- Defined from 10 MHz to 11.1 GHz.
- Defined at reference points TP1A or TP4A. For maximal allowed interconnect characteristics between points TP0 and TP1A or points TP4A and TP5, refer to Section 86A.5.1.1.1 Reference insertion losses of HC Band MCB in IEEE Std 803.2-2010.
- The parameter at any time is the average of signal(+) and signal(-) at that time. This parameter is calculated by applying the histogram function over 1 UI to the common mode signal.
- Defined in coherence with Section 86A.5.3.4 Data Dependent Pulse Width Shrinkage in IEEE Std 803.2-2010.
- The Qdq ratio is defined under the restrictions of the eye mask as defined in IEEE 802.3 section 86A.5.3.6 Eye mask for TP1a and TP4.

Table 83: XLPPi Settings and Configuration

Parameter	Setting/Configuration
Vods	The Vods is the output differential amplitude configurable range. When driving a test load, the minimum value is achieved with AMP=TBD and PRE=TBD, and the maximum value is achieved with AMP=TBD and PRE=TBD. Output amplitude and pre-emphasis are configurable.
Viddp	The Viddp is the input differential voltage. The maximum single-ended voltage (common mode voltage and swing voltage) must not exceed 1.8V.
Vodpp	To achieve the specifications at P1a, the use of emphasis may be needed.
Output Equalization	Tx emphasis may be configured to achieve the required deterministic jitter at the module connector. For emphasis control information, refer to the Functional Specifications.
NOTE: For further information, refer to the Functional Specifications.	

7.6.5.2 XLPPi Interface Transmitter Output Voltage Limits and Definitions

Figure 41: XLPPi Interface Transmitter Output Voltage Limits and Definitions

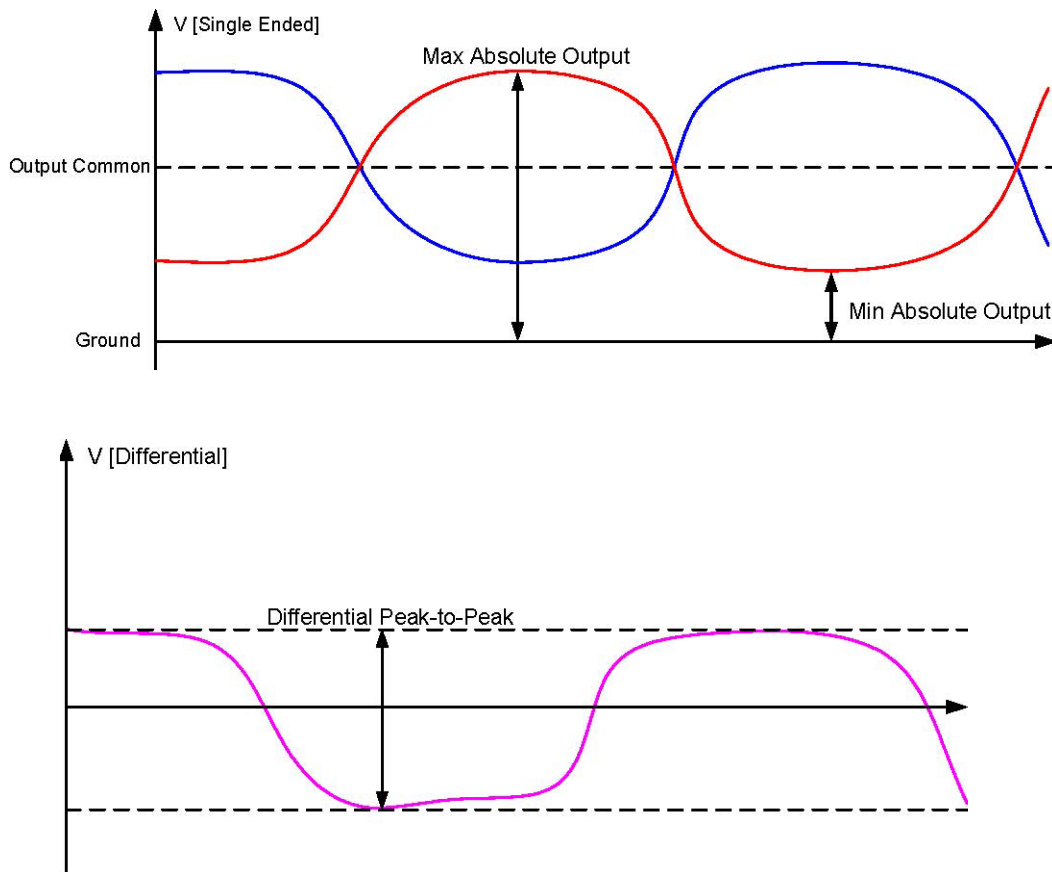
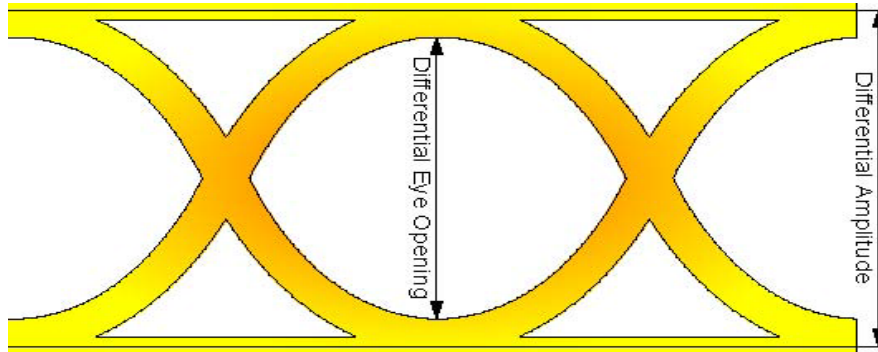

Figure 42: XLPPi Transmitter Output Differential Amplitude and Eye Opening



7.6.6 40 Gbps Attachment Unit Interface (XLAUI) Electrical Characteristics

7.6.6.1 40 Gbps Attachment Unit Interface (XLAUI) Interface Transmitter and Receiver Characteristics

Table 84: XLAUI Interface Transmitter and Receiver Characteristics

Symbol	Parameter	Min	Max	Units	Notes
BR	Baud rate	10.3125		Gbps	–
Bppm	Baud rate tolerance	-100	100	ppm	1
UI	Unit interval	96.969697		ps	–
Transmitter parameters					
Vodpp	Output differential peak-to-peak	400	760	mV	9
Vos	Single-ended output voltage	-0.4	1.9	V	–
DEtx	Output de-emphasis	4.4	7	dB	–
Tr/Tf	Output differential transition time	24	–	ps	2
RLOD	Return loss differential output	12	–	dB	3,4
RLOC	Return loss common mode output	9	–	dB	3,4
Tlskew	Output lane-to-lane skew	–	28	ns	–
Tlskew v	Output lane-to-lane skew variation	–	200	ps	–
dZM	Termination mismatch	–	5	%	10
Vocmac	Output AC common mode voltage	–	15	mVRMS	-
Jdtx	Output jitter - Deterministic, peak-to-peak	–	0.17	UI	-
Jtpptx	Output jitter - Total, peak-to-peak	–	0.32	UI	5, 8
Evodpp	Output eye width at Vodpp (min)	0.24	–	UI	–
Receiver parameters					
Vidpps	Input differential sensitivity	85	–	mV	7
Vidpp	Input differential voltage	–	850	mV	7
RLID	Return loss differential input	12	–	dB	3, 4
RLICD	Return loss common to differential input	15	–	dB	11
Rlskew	Input lane-to-lane skew	–	161	ns	–
Rlskew v	Input lane-to-lane skew variation	–	3.8	ns	–
Jtrlsx	Input jitter - Sinusoidal, low frequency	–	5	UI	12

Table 84: XLAUI Interface Transmitter and Receiver Characteristics (Continued)

Symbol	Parameter	Min	Max	Units	Notes
Jtrsx	Input jitter - Sinusoidal, high frequency	–	0.05	UI	13
Jdrx	Input jitter - Deterministic, peak-to-peak	–	0.42	UI	–
Jtpprx	Input jitter - Total, peak-to-peak	–	0.62	UI	5, 6
Vicmac	Input AC common mode voltage	–	20	mVRMS	–



Note

The load is 100Ω differential for these parameters, unless otherwise specified.

- Defines the allowable reference clock difference and Rx baud rate tolerance relative to nominal. Tx baud rate is derived from multiplication of the reference clock (0 ppm delta).
- Defined from 20 to 80% of the signal's voltage levels when driving a pattern consisting of eight consecutive ones followed by an equal run of zeros with no equalization. Max transition time is limited by mask as defined in IEEE 802.3 section 83A.3.3.5 Transmitter eye mask and transmitter jitter definition.
- Defined from 10 MHz to 2.125 GHz. For 2.125 GHz -11.1 GHz $RLOD/RLID > 6.5 - 13.33 \log(\text{Frequency}/5.5)$ [dB] (Frequency defined in GHz). For 2.125 GHz -7.1 GHz $RLOC > 3.5 - 13.33 \log(\text{Frequency}/5.5)$ [dB] (Frequency defined in GHz). For 7.1 GHz -11.1 GHz $RLOC > 2$ [dB].
- Relative to 100Ω differential and 25Ω common mode. Return loss includes contributions from on-chip circuitry, chip packaging, and off-chip optimized components related to the transmitter/receiver breakout.
- Defined with a Bit Error Rate (BER) of 10^{-12} .
- This parameter does not include sinusoidal components.
- Vidpps refers to the internal eye opening while Vidpp refers to the peak-to-peak.
- The output Tx jitter is defined when applying the effect of a single-pole high-pass filter on the jitter. The high-pass filter 3 dB point is located at 4 MHz.
- Defined with emphasis disabled.
- Defined at 1 MHz frequency. Defined according to section 86A.5.3.2 Termination mismatch in IEEE Std 802.3ba.
- Defined from 10 MHz to 11.1 GHz.
- Defined below 40 kHz.
- Defined from 4 MHz to 20 MHz.

Table 85: XLAUI Settings and Configuration

Parameter	Setting/Configuration
Vods	The Vods is the output differential amplitude configurable range. When driving a test load, the minimum value is achieved with AMP=TBD and PRE=TBD, and the maximum value is achieved with AMP=TBD and PRE=TBD. Output amplitude and pre-emphasis are configurable.
Viddp	The Viddp is the input differential voltage. The maximum single-ended voltage (common mode voltage and swing voltage) must not exceed 1.8V.
Output Equalization	Tx emphasis may be configured to achieve the required deterministic jitter at the module connector. For emphasis control information, refer to the Functional Specifications.
NOTE: For further information, refer to the Functional Specifications.	

7.6.6.2 XLAUI Interface Transmitter Output Voltage Limits and Definitions

Figure 43: XLAUI Interface Transmitter Output Voltage Limits and Definitions

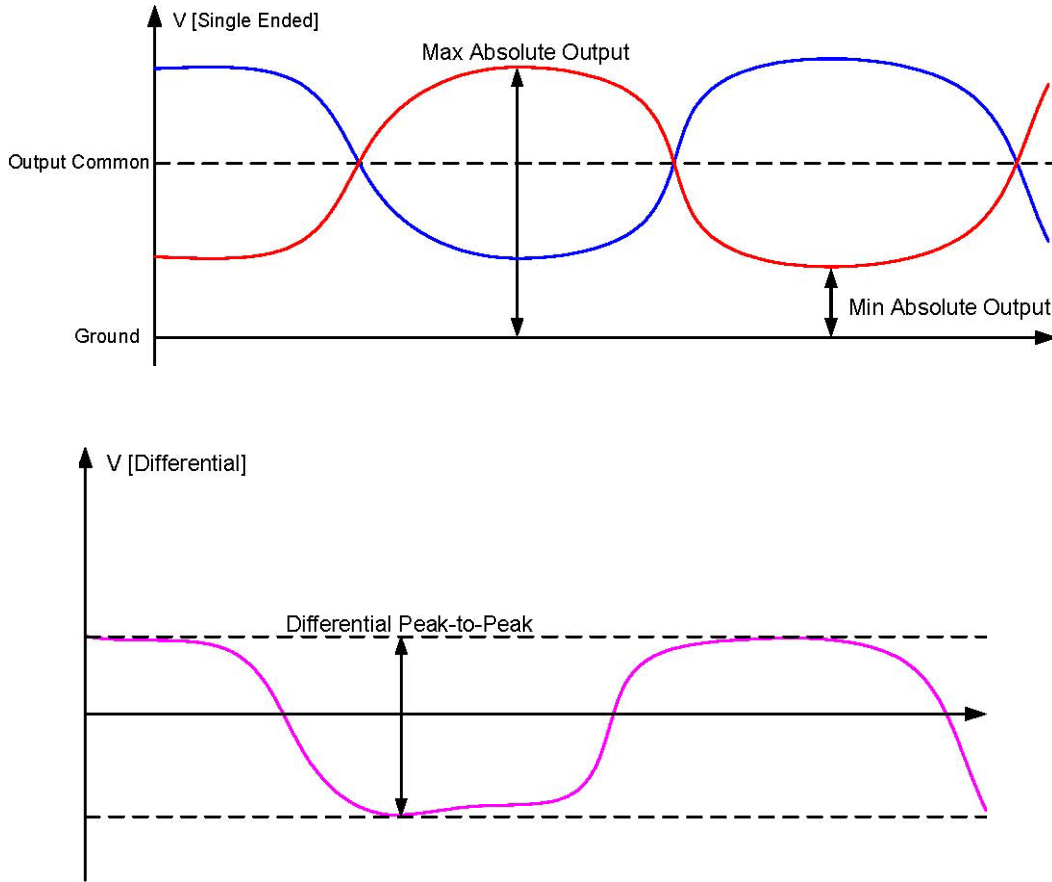
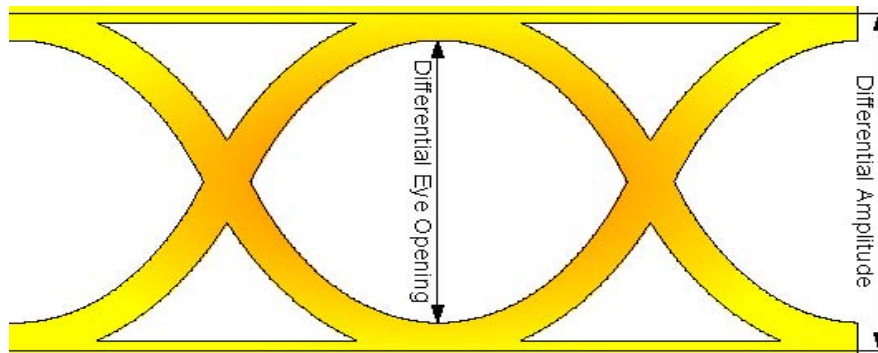

Figure 44: XLAUI Transmitter Output Differential Amplitude and Eye Opening



7.6.7 40GBASE-CR4 Electrical Characteristics

7.6.7.1 40GBASE-CR4 Interface Transmitter and Receiver Characteristics

Table 86: 40GBASE-CR4 Interface Transmitter and Receiver Characteristics

Symbol	Parameter	Min	Max	Units	Notes
BR	Baud rate	10.3125		Gbps	–
Bppm	Baud rate tolerance	-100	100	ppm	1
UI	Unit interval	96.969697		ps	–
Transmitter Parameters					
Vodis	Transmitter disabled output differential noise level	–	30	mV	–
Vodpp	Output differential maximum peak-to-peak	–	1200	mV	–
DEtx	Output de-emphasis	See note 12.		–	12
Vos	Common-mode voltage limits	0.0	1.9	V	–
RLOD	Return loss differential output	10	–	dB	2, 3
Tlskew	Output lane-to-lane skew	–	54	ns	–
Tlskew v	Output lane-to-lane skew variation	–	600	ps	–
Jdtx	Output jitter - Deterministic, peak-to-peak	–	0.15	UI	–
Jdcdtx	Output duty cycle distortion	–	0.035	UI	9, 10
Jrndtx	Output jitter - Random	–	0.15	UI	4
Jtpptx	Output jitter - Total, peak-to-peak	–	0.28	UI	4, 7, 11
Receiver Parameters					
Vidpp	Input differential voltage	–	1200	mV	6
RLID	Return loss differential input	10	–	dB	2, 3
RLIDC	Differential to common mode input return loss	10	–	dB	13
Rlskew	Input lane-to-lane skew	–	134	ns	–
Rlskew v	Input lane-to-lane skew variation	–	3.4	ns	–
Js	Input sinusoidal jitter	–	0.115	UI	5
Jrndrx	Input random jitter	–	0.13	UI	4, 5
Jdcd	Input duty cycle distortion	–	0.035	UI	5
Vinamp	Calibrated far-end crosstalk	–	6.3	mVRMS	5, 8
ICN	Calibrated integrated crosstalk noise	–	3.7	mVRMS	5



Note

The load is 100Ω differential for these parameters, unless otherwise specified.

- Defines the allowable reference clock difference and Rx baud rate tolerance relative to nominal. Tx baud rate is derived from multiplication of the reference clock (zero ppm delta).
- Defined from 50 MHz to 2.5 GHz.
 For 2.5 GHz -7.5 GHz RLOD > 9-12log(Frequency/2.5)[dB] (Frequency defined in GHz).
 For 2.5 GHz -7.5 GHz RLID > 9-12log(Frequency/2.5)[dB] (Frequency defined in GHz).
- Relative to 100Ω differential and 25Ω common mode. Return loss includes contributions from on-chip circuitry, chip packaging, and off-chip optimized components related to the transmitter/receiver breakout.
- Defined with a Bit Error Rate (BER) of 10⁻¹².
- Defined for interference tests according to IEEE 802.3 section 85.8.4.2 Receiver interference tolerance test.
- Vidpp refers to the peak-to-peak.
- The output Tx jitter is defined when applying the effect of a single-pole high-pass filter on the jitter. The high-pass filter 3 dB point is located at 4 MHz.
- The receiver tolerates noise at an amplitude specified under receiver interference tolerance test1.
 The value for test2 is 2.2 mV.
- Jdcctx is included as a part of Jdctx.
- Defined for a 1010 pattern and includes the entire range of emphasis.
- The jitter is defined with emphasis off.
- The transmitter output waveform follows IEEE requirements as specified in section 85.8.3.3 Transmitter output waveform.
- Defined from 10 MHz to 10 GHz.

Table 87: 40GBASE-CR4 Settings and Configuration

Parameter	Setting/Configuration
Viddp	The Viddp is the input differential voltage. The maximum single-ended voltage (common mode voltage and swing voltage) must not exceed 1.8V.
Output Equalization	The default as determined by the IEEE is 3 TAP FIR optimized per interconnect.
NOTE: For further information, refer to the Functional Specifications.	

7.6.7.2 40GBASE-CR4 Interface Transmitter Output Voltage Limits and Definitions

Figure 45: 40GBASE-CR4 Interface Transmitter Output Voltage Limits and Definitions

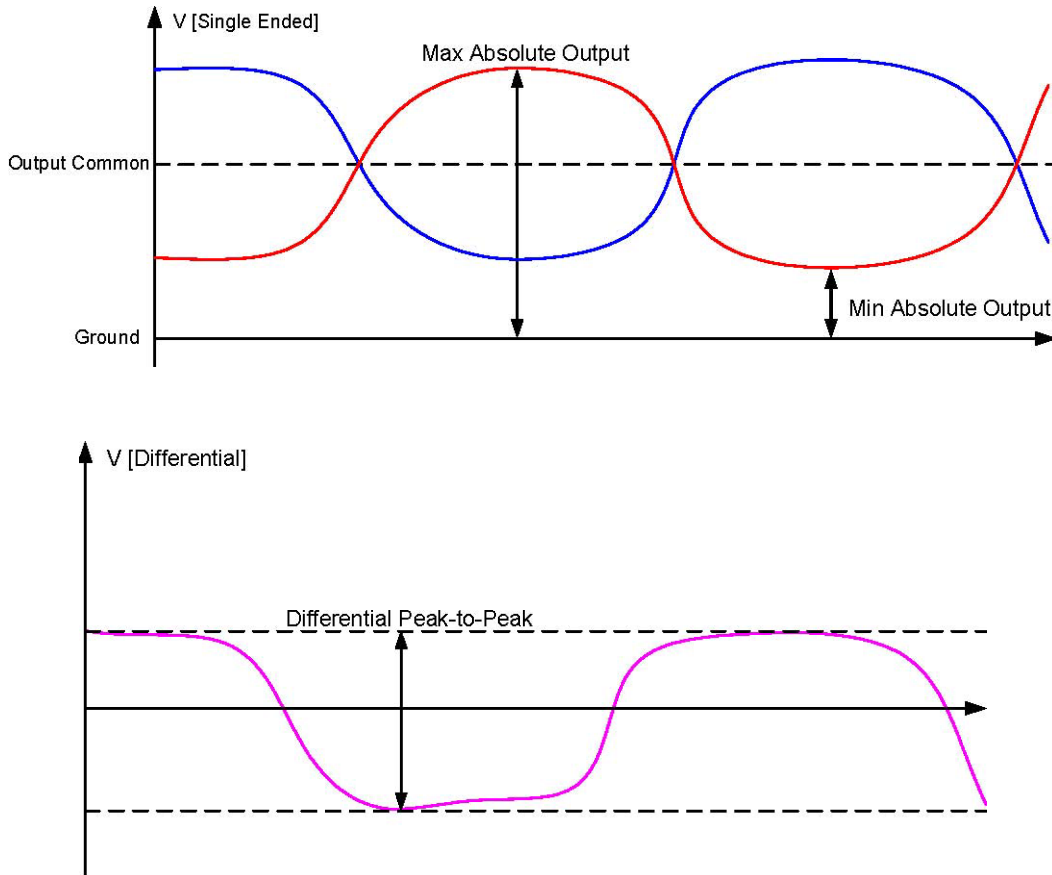
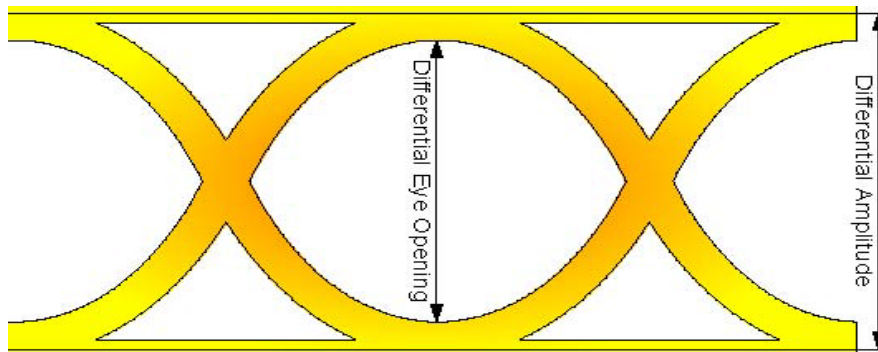

Figure 46: 40GBASE-CR4 Transmitter Output Differential Amplitude and Eye Opening



7.6.8 40GBASE-KR4 Electrical Characteristics

7.6.8.1 40GBASE-KR4 Interface Transmitter and Receiver Characteristics

Table 88: 40GBASE-KR4 Interface Transmitter and Receiver Characteristics

Symbol	Parameter	Min	Max	Units	Notes
BR	Baud rate	10.3125		Gbps	–
Bppm	Baud rate tolerance	-100	100	ppm	1
UI	Unit interval	96.969697		ps	–
Transmitter Parameters					
Vodis	Transmitter disabled output differential noise level	–	30	mV	–
Vodpp	Output differential maximum peak-to-peak	–	1200	mV	–
Vos	Common-mode voltage limits	0	1.9	V	–
Tr/Tf	Output differential transition time	24	47	ps	10
RLOD	Return loss differential output	9	–	dB	2, 3
RLOC	Return loss common mode output	6	–	dB	2, 3
Tlskew	Output lane-to-lane skew	–	557	UI	–
Tlskew v	Output lane-to-lane skew variation	–	6	UI	–
Jdtx	Output jitter - Deterministic, peak-to-peak	–	0.15	UI	–
Jdcctx	Output duty cycle distortion	–	0.035	UI	10, 11
Jrndtx	Output jitter - Random	–	0.15	UI	4
Jtpptx	Output jitter - Total, peak-to-peak	–	0.28	UI	4, 7
Receiver Parameters					
Vidpp	Input differential voltage	–	1200	mV	6
RLID	Return loss differential input	9	–	dB	2, 3
Rlskew	Input lane-to-lane skew	–	1382	UI	–
Rlskew v	Input lane-to-lane skew variation	–	35	UI	–
Js	Input sinusoidal jitter	–	0.115	UI	5
Jrndrx	Input random jitter	–	0.13	UI	4, 5
Jdcd	Input duty cycle distortion	–	0.035	UI	5
Vinamp	Input broadband noise amplitude	–	5.2	mVRMS	5, 9

Table 88: 40GBASE-KR4 Interface Transmitter and Receiver Characteristics (Continued)

Symbol	Parameter	Min	Max	Units	Notes
mTC	Test Channel Magnitude factor		1	–	5, 8



Note

The load is 100Ω differential for these parameters, unless otherwise specified.

- Defines the allowable reference clock difference and Rx baud rate tolerance relative to nominal.
Tx baud rate is derived from multiplication of the reference clock (0 ppm delta).
- Defined from 50 MHz to 2.5 GHz.
For 2.5 GHz -7.5 GHz RLOD > 9-12log(Frequency/2.5)[dB] (Frequency defined in GHz).
For 2.5 GHz -7.5 GHz RLOC > 6-12log(Frequency/2.5)[dB] (Frequency defined in GHz).
For 2.5 GHz -7.5 GHz RLID > 9-12log(Frequency/2.5)[dB] (Frequency defined in GHz).
- Relative to 100Ω differential and 25Ω common mode. Return loss includes contributions from on-chip circuitry, chip packaging, and off-chip optimized components related to the transmitter/receiver breakout.
- Defined with a Bit Error Rate (BER) of 10⁻¹².
- Defined for interference tests according to IEEE 802.3 Annex 69A.
For informative interconnect characteristics, refer to IEEE 802.3 Annex 69B.
- Vidpp refers to the peak-to-peak.
- The output Tx jitter is defined when applying the effect of a single-pole high-pass filter on the jitter.
The high-pass filter 3 dB point is located at 4 MHz.
- mTC describes the insertion loss transmission magnitude relative to the maximal allowed fitted attenuation mask A_{max} over a predefined frequency range.
Defined for test1. The value for test2 is 0.5.
- The receiver tolerates noise at an amplitude specified under receiver interference tolerance test1. The value for test2 is 12 mV.
- Jdcctx is included as a part of Jdctx.
- Defined for a 1010 pattern and includes the entire range of emphasis.
- The transmitter output waveform follows IEEE requirements as specified in section 72.7.1.10 Transmitter output waveform requirements.

Table 89: 40GBASE-KR4 Settings and Configuration

Parameter	Setting/Configuration
Viddp	The Viddp is the input differential voltage. The maximum single-ended voltage (common mode voltage and swing voltage) must not exceed 1.8V.

Table 89: 40GBASE-KR4 Settings and Configuration (Continued)

Parameter	Setting/Configuration
Output Equalization	The default as determined by the IEEE is 3 TAP FIR optimized per interconnect.
NOTE: For further information, refer to the Functional Specifications.	

7.6.8.2 40GBASE-KR4 Interface Transmitter Output Voltage Limits and Definitions

Figure 47: 40GBASE-KR4 Interface Transmitter Output Voltage Limits and Definitions

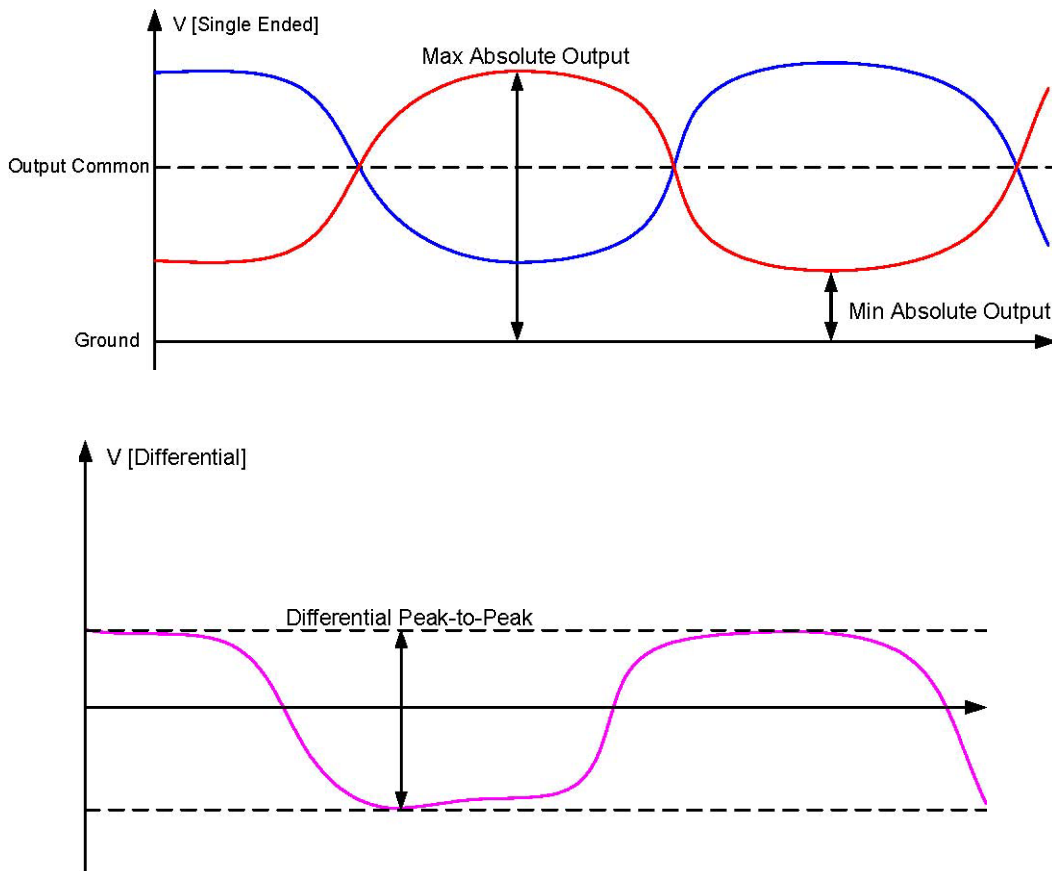
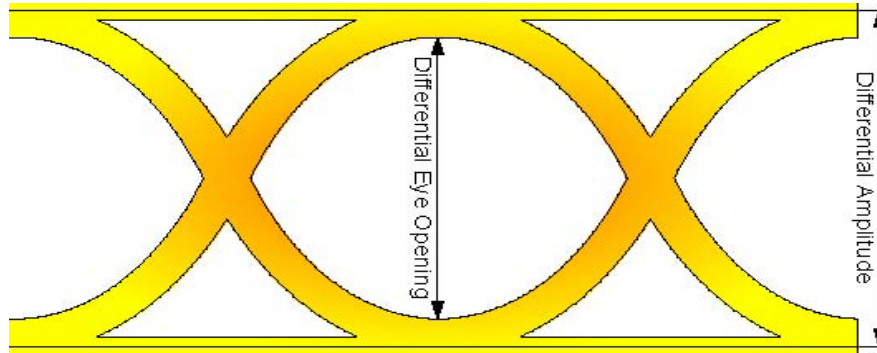

Figure 48: 40GBASE-KR4 Transmitter Output Differential Amplitude and Eye Opening



7.6.9 SFP+ Interface (SFI) Limiting Module Electrical Characteristics

7.6.9.1 SFI Transmitter and Receiver Characteristics

Table 90: SFI Transmitter and Receiver Characteristics

Symbol	Parameter	Min	Max	Units	Notes
BR	Baud rate	10.3125		Gbps	–
Bppm	Baud rate tolerance	-100	100	ppm	1
UI	Unit interval	96.969697		ps	–
Transmitter parameters					
Vodpp	Output differential peak-to-peak	190	700	mV	9,14,7
Vos	Single-ended output voltage	-0.3	1.9	V	13
DEtx	Output de-emphasis	4.4	7	dB	13
Tr/Tf	Output differential transition time	24	–	ps	2, 13
RLOD	Return loss differential output	12	–	dB	3,4,13
RLOC	Return loss common mode output	9	–	dB	3,4,13
dZM	Termination mismatch	–	5	%	10,13
Vocmac	Output AC common mode voltage	–	12	mVRMS	13,15
Jutx	Output jitter - Uncorrelated, RMS	–	0.023	UI	5,14,12
Jddpw st	Output jitter - Data dependent pulse width shrinkage	–	0.055	UI	14
Jddtx	Output jitter - Data dependent, peak-to-peak	–	0.1	UI	14
Jtpptx	Output jitter - Total, peak-to-peak	–	0.28	UI	8,14,17
Receiver parameters					
Vidpps	Input differential sensitivity	300	–	mV	7,14
Vidpp	Input differential voltage	–	850	mV	7,14
RLID	Return loss differential input	12	–	dB	3,4,13
RLICD	Reflected input common mode to differential conversion	15	–	-dB	11,13
J2	Input 99% jitter - peak-to-peak	–	0.42	UI	6,14,16
Jddpw sr	Input jitter - Data dependent pulse width shrinkage	–	0.3	UI	14, 16
Jtpprx	Input jitter - Total, peak-to-peak	–	0.7	UI	5,14,16
Vicmac	Input AC common mode voltage, RMS	–	7.5	mVRMS	14,15,16



Note

The load is 100Ω differential for these parameters, unless otherwise specified.

The reference points are according to Table 10 SFI Reference Points in SFF 8431 Rev. 4.1 standard.

- Defines the allowable reference clock difference and Rx baud rate tolerance relative to nominal. Tx baud rate is derived from multiplication of the reference clock (zero ppm delta).
- Defined from 20 to 80% of the signal's voltage levels when driving a pattern consisting of 8 consecutive ones followed by an equal run of zeros with no equalization. Max transition time is limited by mask as defined in SFF 8431 Rev. 4.1 standard. Figure 19 Transmitter Differential Output Compliance Mask at B and B.
- RLOD/RLID are defined from 10 MHz to 2.8 GHz.
- Relative to 100Ω differential and 25Ω common mode. Return loss includes contributions from on-chip circuitry, chip packaging, and off-chip optimized components related to the transmitter/receiver breakout.
- Defined with a Bit Error Rate (BER) of 10^{-12} .
- Defines with all but 1 percent of occurrences.
- Vidpps refers to the internal eye opening while Vidpp refers to the peak-to-peak.
- The output Tx jitter is defined when applying the effect of a single-pole, high-pass filter on the jitter. The high-pass filter 3 dB point is located at 4 MHz.
- Defined with emphasis disabled.
- Defined at 1 MHz frequency. Defined according to section D.16 Termination Mismatch in SFF 8431 Rev. 4.1 standard.
- Defined from 10 MHz to 11.1 GHz.
- Jutx includes random jitter.
- Defined at reference points A or D.
- Defined at reference points B or C. For maximal allowed interconnect characteristics between points A and B or points C and D, refer to Appendix A SFI Channel Recommendation in SFF 8431 Rev. 4.1 standard.
- The parameter at any time is the average of signal(+) and signal(-) at that time. This parameter is calculated by applying the histogram function over one UI to the common mode signal.
- Defined in coherence with Table 14 Host receiver supporting limiting module input in SFF-8431 Rev. 4.1 standard.
- Defined with a Hit Ratio of 5×10^{-5} .

Table 91: SFI Settings and Configuration

Parameter	Setting/Configuration
Viddp	The Viddp is the input differential voltage. The maximum single-ended voltage (common mode voltage and swing voltage) must not exceed 1.8V.
Output Equalization	De-emphasis to be set to minimize data dependent jitter at compliance point B. For compliance point definition refer to chapter 3.3 SFI Test Points Definition and Measurements in the SFF-8431 standard.
NOTE: For further information, refer to the Functional Specifications.	

7.6.9.2 SFP+ Direct Attach Cable (10GSFP+CU Appendix E) Transmitter and Receiver Characteristics

Table 92: 10GSFP+CU Transmitter and Receiver Characteristics

Symbol	Parameter	Min	Max	Units	Notes
BR	Baud rate	10.3125		Gbps	–
Bppm	Baud rate tolerance	-100	100	ppm	1
UI	Unit interval	96.969697		ps	–
Transmitter Parameters					
Vodpp	Output differential peak-to-peak	190	700	mV	9, 14, 17
VMAT	Output voltage modulation amplitude peak-to-peak	300	–	mV	6, 14
Vos	Single-ended output voltage	-0.3	1.9	V	13
Qsq	Signal to noise ratio quality	63	–	–	14, 18
DEtx	Output de-emphasis	4.4	7	dB	13
Tr/Tf	Output differential transition time	24	–	ps	2, 13
RLOD	Return loss differential output	12	–	dB	3, 4, 13
RLOC	Return loss common mode output	9	–	dB	3, 4, 13
dZM	Termination mismatch	–	5	%	10, 13
Vocmac	Output AC common mode voltage	–	12	mVRMS	13, 15
TWDPc	Copper cable stressor transmitter penalty	–	10.7	dBe	14, 19
Jutx	Output jitter - Uncorrelated, RMS	–	0.023	UI	5, 14, 12
Jddpw st	Output jitter - Data dependent pulse width shrinkage	–	0.055	UI	14
Jddtx	Output jitter - Data dependent, peak-to-peak	–	0.1	UI	14
Jtpptx	Output jitter - Total, peak-to-peak	–	0.28	UI	8, 4, 17
Receiver Parameters					
Vidpp	Input differential voltage	–	850	mV	7, 14
VMAR	Input voltage modulation amplitude peak-to-peak	180	–	mV	6, 14
RLID	Return loss differential input	12	–	dB	3, 4, 13
RLICD	Reflected input common mode to differential conversion	15	–	dB	11, 13
WDPC	Waveform distortion penalty of the ISI generator	–	9.3	dBe	14, 19
Vinamp	Input broadband noise amplitude	–	2.14	mVRMS	14, 20

Table 92: 10GSFP+CU Transmitter and Receiver Characteristics (Continued)

Symbol	Parameter	Min	Max	Units	Notes
Vicmac	Input AC common mode voltage, RMS	–	13.5	mVRMS	14, 15, 16



Note

The load is 100Ω differential for these parameters, unless otherwise specified.

- The reference points are according to Table 10 SFI Reference Points in SFF 8431 Rev. 4.1 standard.
- Defines the allowable reference clock difference and Rx baud rate tolerance relative to nominal. Tx baud rate is derived from multiplication of the reference clock (zero ppm delta).
- Defined from 20 to 80% of the signal's voltage levels when driving a pattern consisting of 8 consecutive ones followed by an equal run of zeros with no equalization. Max transition time is limited by mask as defined in SFF 8431 Rev. 4.1 standard. Figure 19 Transmitter Differential Output Compliance Mask at B and B.
- RLOD/RLID are defined from 10 MHz to 2.8 GHz.
- For 2.8 GHz -11.1 GHz RLOD/RLID > 8.15 - 13.33 log(Frequency/5.5) [dB] (Frequency defined in GHz). RLOC is defined from 10.0 MHz to 4.74 GHz. For 4.74 GHz -7.1 GHz RLOC > 8.1 - 13.33 log(Frequency/5.5) [dB] (Frequency defined in GHz).
- Relative to 100Ω differential and 25Ω common mode. Return loss includes contributions from on-chip circuitry, chip packaging, and off-chip optimized components related to the transmitter/receiver breakout.
- Defined with a Bit Error Rate (BER) of 10⁻¹².
- For test definition refer to section D.7 Voltage Modulation Amplitude (VMA) in SFF 8431 Rev. 4.1 standard.
- Vidpps refers to the internal eye opening while Vidpp refers to the peak-to-peak.
- The output Tx jitter is defined when applying the effect of a single-pole, high-pass filter on the jitter. The high-pass filter 3 dB point is located at 4 MHz.
- Defined with emphasis disabled.
- Defined at 1 MHz frequency. Defined according to section D.16 Termination Mismatch in SFF 8431 Rev. 4.1 standard.
- Defined from 10 MHz to 11.1 GHz.
- Jutx includes random jitter.
- Defined at reference points A or D.
- Defined at reference points B or C. For maximal allowed interconnect characteristics between points A and B or points C and D, refer to Appendix A SFI Channel Recommendation in SFF 8431 Rev. 4.1 standard.
- The parameter at any time is the average of signal(+) and signal(-) at that time. This parameter is calculated by applying the histogram function over one UI to the common mode signal.
- Defined in coherence with Table 14 Host receiver supporting limiting module input in SFF-8431 Rev. 4.1 standard.
- Defined with a Hit Ratio of 5*10⁻⁵.
- Qsq = 1/RN. For test definition of RN refer to section D.8 Relative noise (RN) in SFF 8431 Rev. 4.1 standard.
- For calculation, refer to Appendix G Mat-lab code for TWDP in SFF 8431 Rev. 4.1 standard.
- Defined for interference tests according to D. 11 Test Method For A Host Receiver For A Limiting Module in SFF 8431 Rev. 4.1 standard.

Table 93: 10GSFP+CU Settings and Configuration

Parameter	Setting/Configuration
Viddp	The Viddp is the input differential voltage. The maximum single-ended voltage (common mode voltage and swing voltage) must not exceed 1.8V.
Output Equalization	The default as determined by the IEEE is 3 TAP FIR optimized per interconnect.

NOTE: For further information, refer to the Functional Specifications.

Figure 49: SFI Transmitter Output Voltage Limits and Definitions

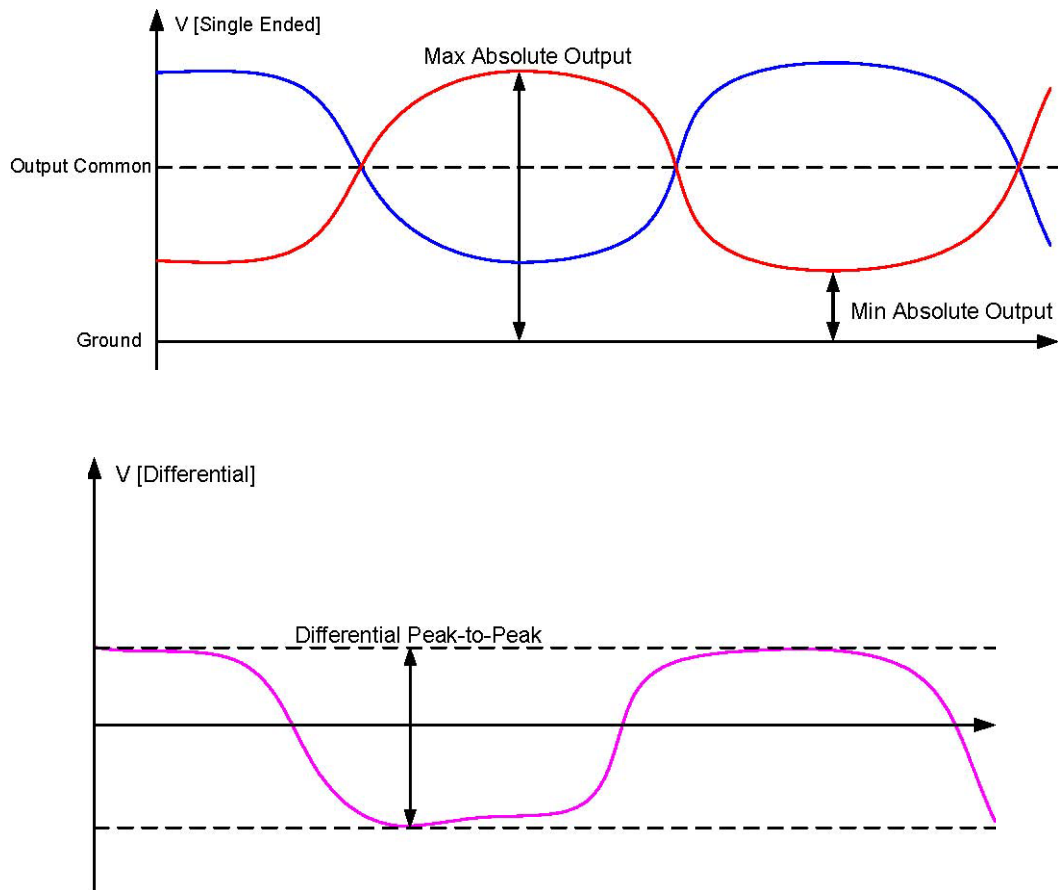
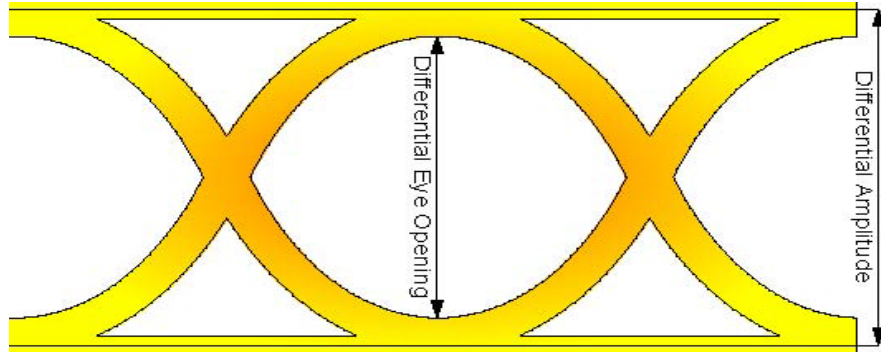

Figure 50: SFI Transmitter Output Differential Amplitude and Eye Opening



7.6.10 10 Gigabit Small Form Factor Pluggable Interface (XFI) Electrical Characteristics

7.6.10.1 XFI Interface Transmitter and Receiver Characteristics

Table 94: XFI Interface Transmitter and Receiver Characteristics

Symbol	Parameter	Min	Max	Units	Notes
BR	Baud rate	10.3125		Gbps	–
Bppm	Baud rate tolerance	-100	100	ppm	1
UI	Unit interval	96.969697		ps	–
Transmitter Parameters					
Zod	Reference output differential impedance	100		Ω	1
dRom	Termination output mismatch	–	5	%	1
Vcm	DC Common Mode Voltage	0	1.9	V	–
tRH/tFH	Output rise and fall time	24	–	ps	2
Vocm	Output AC common mode voltage - 15 mV(RMS) 1, 7	–	15	mVRMS	1, 7
SDD22	Differential output return loss	20	–	dB	3
		10	–	dB	4
		See note #5.		dB	5, 12
SCC22	Common mode output return loss	6	–	dB	6, 12
Txjit	Transmitter output jitter specifications	See note # 7.		–	1, 7
Receiver Parameters					
Zid	Reference input differential impedance	100		Ω	1
dRim	Termination input mismatch	–	5	%	1
Vicm	Input AC common mode voltage	–	25	mVRMS	1
SDD22	Differential output return loss	20	–	dB	3
		10	–	dB	4
		See note #5.		dB	5, 12
SCC11	Common mode input return loss	6	–	dB	9, 10, 12
SCD11	Differential to common mode input conversion	12	–	dB	9
Rxjit	Receiver input jitter specifications	See note # 11.		–	1, 11



Note

The load is 100Ω differential for these parameters, unless otherwise specified.

- Defines the allowable reference clock difference and Rx baud rate tolerance relative to nominal.
 - Tx baud rate is derived from multiplication of the reference clock (0 ppm delta).
 - Defined from 50.0 MHz to 2.5 GHz.
 - For 2.5 GHz -7.5 GHz $RLOD > 9 - 12 \log(\text{Frequency}/2.5)$ [dB] (Frequency defined in GHz).
 - For 2.5 GHz -7.5 GHz $RLID > 9 - 12 \log(\text{Frequency}/2.5)$ [dB] (Frequency defined in GHz).
 - Relative to 100Ω differential and 25Ω common mode. Return loss includes contributions from on-chip circuitry, chip packaging, and off-chip optimized components related to the transmitter/receiver breakout.
 - Defined with a Bit Error Rate (BER) of 10^{-12} .
 - Defined for compliant transmitter and interference tests according to IEEE 802.3 section 85.8.4.2 Receiver interference tolerance test.
 - Defined with a cable interconnect $4.6 < WDPC < 4.8$ that complies with interconnect parameters definition.
 - Vidpp refers to the peak-to-peak.
 - The output Tx jitter is defined when applying the effect of a single-pole, high-pass filter on the jitter. The high-pass filter 3 dB point is located at 4 MHz.
 - As calculated using code in Appendix G Matlab Code For TWDP in SFF-8431 version 4.1 standard.
 - The parameter value includes the module compliance boards.
 - Jdcctx is included as a part of Jdctx.
 - Defined for a 1010 pattern and includes the entire range of emphasis.
 - The jitter is defined with emphasis off.
 - Transmitter output waveform follows IEEE requirements as specified in IEEE Std 802.3-2008 section 72.7.1.11 Transmitter output waveform requirements.
 - Defined from 10 MHz to 10 GHz.
 - As defined in D.7 Voltage Modulation Amplitude in SFF-8431 version 4.1 standard.
 - Defined between host device pins (with host device removed) and Host Compliance Board (HCB) SMAs.
 - Defined from 10.0 MHz to 5 GHz.
For 5 GHz -11.1 GHz $HBRL > 23.25 - 8.75 \log(\text{Frequency}/5)$ [dB] (Frequency defined in GHz).
 - Defined for a 1010 pattern according to IEEE Std 802.3-2008 section 72.6.10.4.2 Training.
 - The interconnect parameters are defined with compliant transmitter as defined in Transmitter Parameters section.
 - This value is applied for Vamp (min).
-

7.6.11 10GBASE-KR Electrical Characteristics

7.6.11.1 10GBASE-KR Interface Transmitter and Receiver Characteristics

Table 95: 10GBASE-KR Interface Transmitter and Receiver Characteristics

Symbol	Parameter	Min	Max	Units	Notes
BR	Baud rate	10.3125		Gbps	–
Bppm	Baud rate tolerance	-100	100	ppm	1
UI	Unit interval	96.969697		ps	–
Transmitter Parameters					
Vodis	Transmitter disabled output differential noise level	–	30	mV	–
Vodpp	Output differential maximum peak-to-peak	–	1200	mV	–
Vos	Common-mode voltage limits	0	1.9	V	–
Tr/Tf	Output differential transition time	24	47	ps	10
RLOD	Return loss differential output	9	–	dB	2, 3
RLOC	Return loss common mode output	6	–	dB	2, 3
Jdtx	Output jitter - Deterministic, peak-to-peak	–	0.15	UI	–
Jdcctx	Output duty cycle distortion	–	0.035	UI	10, 11
Jrndtx	Output jitter - Random	–	0.15	UI	4
Jtpptx	Output jitter - Total, peak-to-peak	–	0.28	UI	4, 7
Receiver Parameters					
Vidpp	Input differential voltage	–	1200	mV	6
RLID	Return loss differential input	9	–	dB	2, 3
Js	Input sinusoidal jitter	–	0.15	UI	5
Jrndrx	Input random jitter	–	0.13	UI	4, 5
Jdcd	Input duty cycle distortion	–	0.035	UI	5
Vinamp	Input broadband noise amplitude	–	5.2	mVRMS	5, 9
mTC	Test channel magnitude factor	1	–	–	5, 8



The load is 100Ω differential for these parameters, unless otherwise specified.

- Defines the allowable reference clock difference and Rx baud rate tolerance relative to nominal. Tx baud rate is derived from multiplication of the reference clock (0 ppm delta).
- Defined from 50 MHz to 2.5 GHz.
For 2.5 GHz -7.5 GHz RLOD > 9 - 12log(Frequency/2.5)[dB] (Frequency defined in GHz).
For 2.5 GHz -7.5 GHz RLOC > 6 - 12log(Frequency/2.5)[dB] (Frequency defined in GHz).
For 2.5 GHz -7.5 GHz RLID > 9 - 12log(Frequency/2.5)[dB] (Frequency defined in GHz).
- Relative to 100Ω differential and 25Ω common mode. Return loss includes contributions from on-chip circuitry, chip packaging, and off-chip optimized components related to the transmitter/receiver breakout.
- Defined with a Bit Error Rate (BER) of 10⁻¹².
- Defined for interference tests according to IEEE 802.3 Annex 69A. For informative interconnect characteristics, refer to IEEE 802.3 Annex 69B.
- Vidpp refers to the peak-to-peak.
- The output Tx jitter is defined when applying the effect of a single-pole high-pass filter on the jitter. The high-pass filter 3 dB point is located at 4 MHz.
- mTC describes the insertion loss transmission magnitude relative to the maximal allowed fitted attenuation mask A_{max} over a predefined frequency range. Defined for test1. The value for test2 is 0.5.
- The receiver tolerates noise at an amplitude specified under receiver interference tolerance test1. The value for test2 is 12 mV.
- Jdcctx is included as a part of Jdctx.
- Defined for a 1010 pattern and includes the entire range of emphasis.
- The transmitter output waveform follows IEEE requirements as specified in section 72.7.1.10 Transmitter output waveform requirements.

Table 96: 10GBASE-KR Settings and Configuration

Parameter	Setting/Configuration
Vidpp	The Vidpp is the input differential voltage. The maximum single-ended voltage (common mode voltage and swing voltage) must not exceed 1.8V.
Output Equalization	The default as determined by the IEEE is 3 TAP FIR optimized per interconnect. 3 TAP FIR capabilities comply with the IEEE 802.3 standard section 72.7.1.10 Transmitter Output Waveform. For FIR control information, refer to the Functional Specifications.
NOTE: For further information, refer to the Functional Specifications.	

7.6.11.2 10GBASE-KR Interface Transmitter Output Voltage Limits and Definitions

Figure 51: 10GBASE-KR Interface Transmitter Output Voltage Limits and Definitions

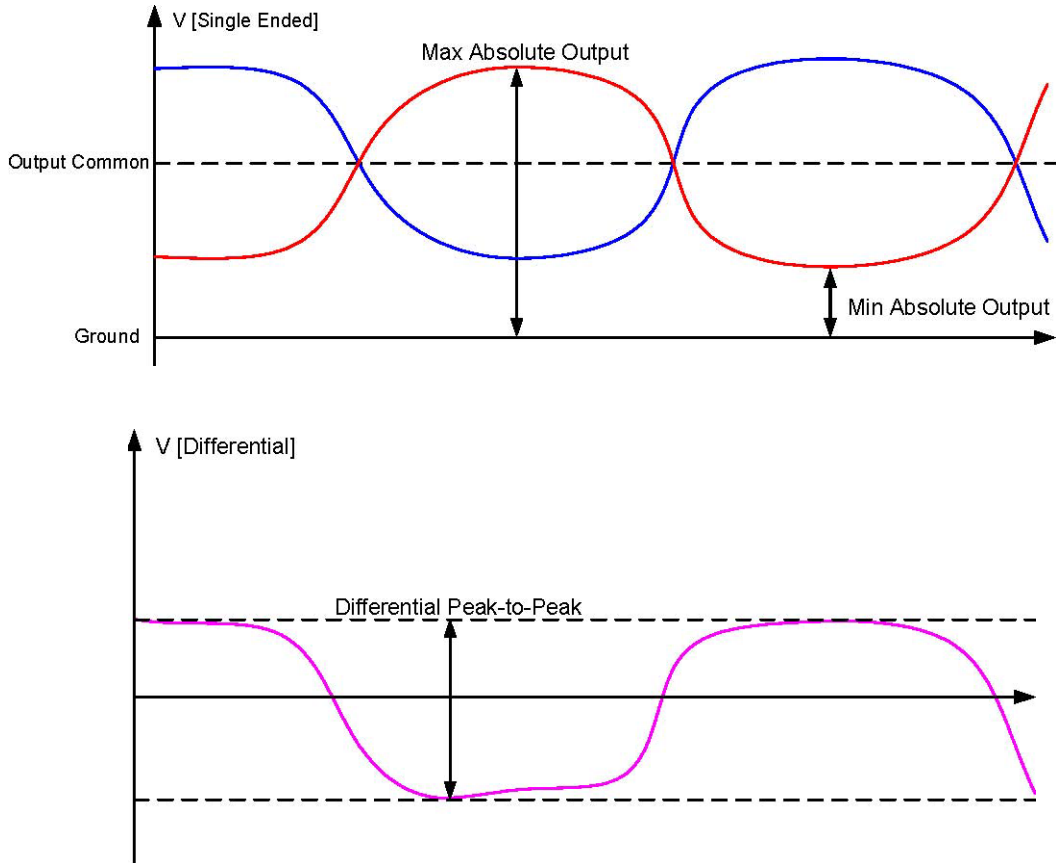
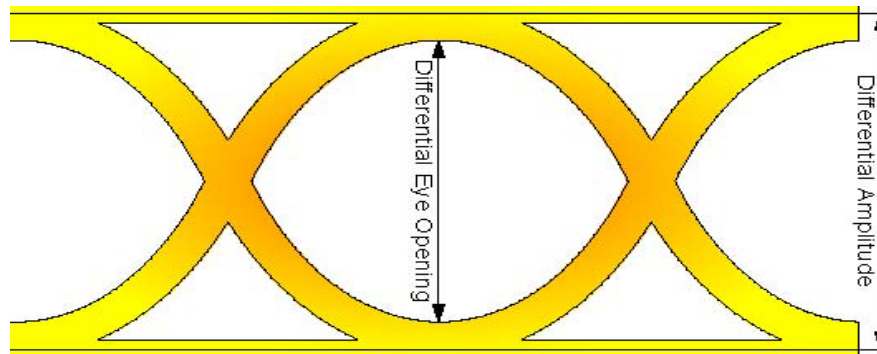

Figure 52: 10GBASE-KR Transmitter Output Differential Amplitude and Eye Opening



7.7 Reference Clock

Table 97: Reference Clock

(Over full range of values listed in the Recommended Operating Conditions unless otherwise specified)

Symbol	Parameter	Condition	Min	Typ	Max	Units
F _{CLK}	Clock Frequency ¹		-100 ppm	156.25	+100 ppm	MHz
T _R , T _F	Rise and Fall Times	20 to 80% of V _{PPD}	–	0.5	0.8	ns
V _{PPD}	Peak-to-Peak Differential Voltage		0.4	0.8	1.2	V
Z _{IND}	Input Impedance	Differential	80	100	120	Ω
Z _{INC}	Input Impedance	Common Mode	–	100K	–	Ω
T _{DUTY}	Duty Cycle		45	50	55	%
J _{RMS}	RMS Jitter	Integrated from 12 KHz to 20 MHz ²	–	0.17	0.5	ps

1. CLKP/N must have an external AC-coupling capacitor.
2. Specification assumes that there are no spurs in the phase noise plot.

Figure 53: Reference Clock Input Waveform

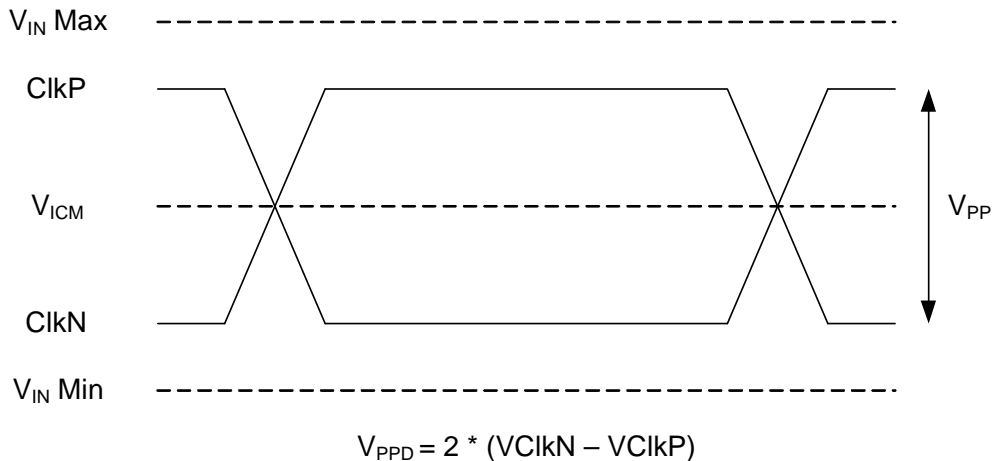

7.8 Output 25 MHz Clock

Table 98: Output 25 MHz Clock

(Over full range of values listed in the Recommended Operating Conditions unless otherwise specified)

Symbol	Parameter	Condition	Min	Typ	Max	Units
F_{CLK}	Clock Frequency	–	–	25	–	MHz
J _{RMS}	RMS Jitter	–	–	500	–	ps, rms
V_{DIFF}	Differential Amplitude Peak-to-Peak	–	760	780	800	mV
T_R/T_F	Rise/Fall Time	2 pF, 50 Ω termination/load	100	115	130	ps

7.9 Latency

The transmit latency is measured from the input of the PPM FIFO to the SERDES transmit pin.

The receive latency is measured from the SERDES receive pin to the input of the PPM FIFO.

The total latency in each direction is the sum of receive and transmit latency in the path.

Table 99: Chip Pin-to-pin Latency (Rx + Tx)

Parameter	Latency Variation	(Dynamic) Latency Jitter	Min	Typ	Max
1G PCS (1 lane)	–	–	–	194.96	–
2.5G PCS (1 lane)	–	–	–	74.95	–
5G PCS (1 lane)	–	–	–	313.36	–
10G PCS - No FEC (1 lane)	–	–	–	144.52	–
10G PCS - KR FEC (1 lane)	–	–	–	434.07	–
25G PCS - No FEC (1 lane)	22	3.8	57	70	79
25G PCS - KR FEC (1 lane)	22	3.8	172	186	194
25G PCS - RS FEC (1 lane)	46	24.3	456	484.6	502
40G PCS - No FEC (4 lane)	33	17.6	167	180	200
40G PCS - KR FEC (4 lane)	32	17.6	455	468	487
50G PCS - No FEC (4 lane)	0	14.08	–	143.6	–
50G PCS - KR FEC (4 lane)	0	14.08	–	374.5	–
50G PCS - No FEC (2 lane)	0	14.08	–	139.89	–
50G PCS - KR FEC (2 lane)	0	14.08	–	372.02	–
50G PCS - RS FEC (2 lane)	0	14.08	–	360.85	–
100G PCS - No FEC (4 lane)	39	4.5	134	151	173
100G PCS - RS FEC (4 lane)	44	4.5	215	246	259

8 Mechanical Drawings

8.1 Package Mechanical Drawings

Figure 54: 169-pin FCBGA 14 x 14 Package Mechanical Drawings — Top and Side View

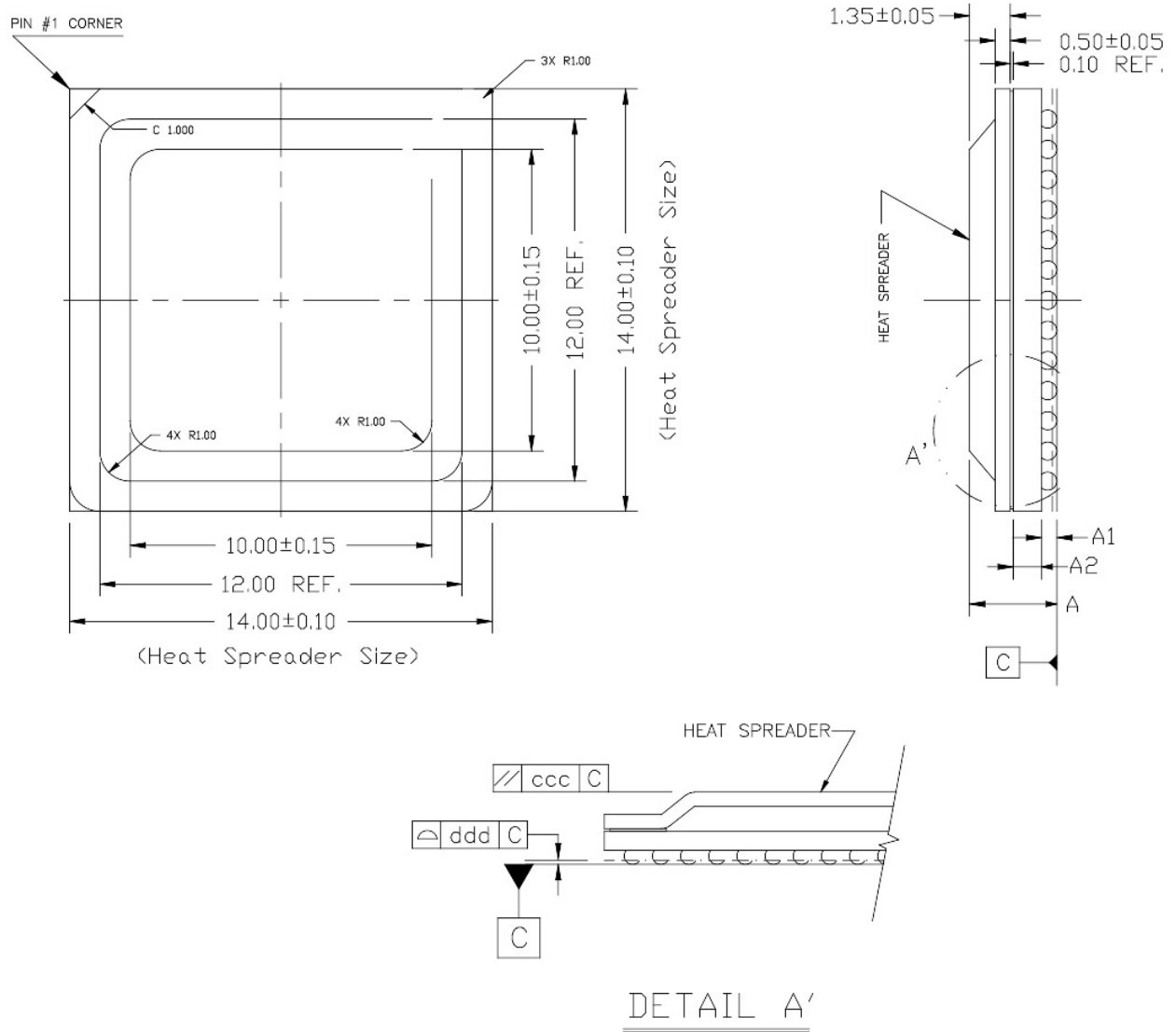
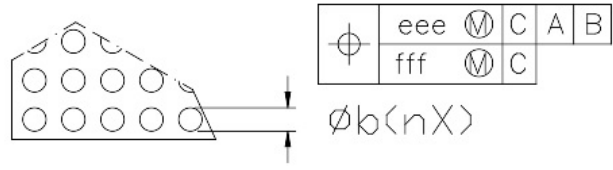
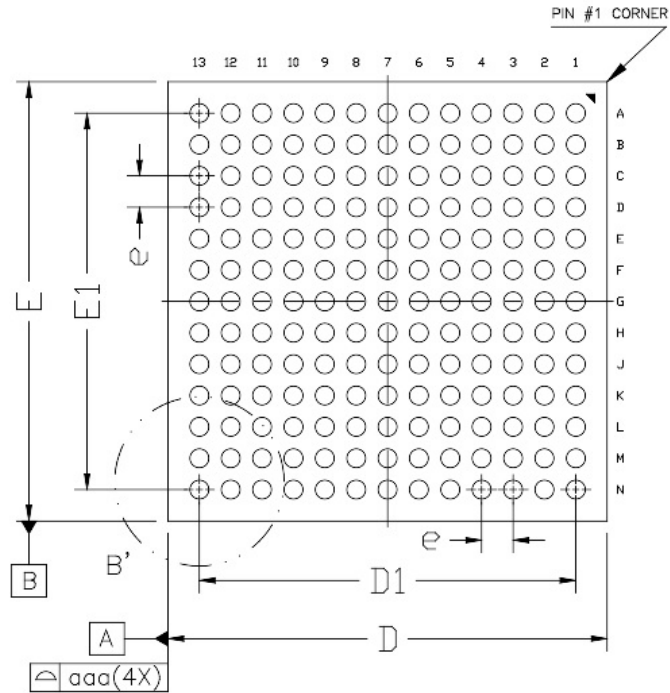

Figure 55: 169-pin FCBGA 14 x 14 Package Mechanical Drawings — Bottom View



DETAIL B'

Table 100: 169-pin FCBGA (14 mm x 14 mm) Package Dimensions

	Symbol	Dimension in mm		
		Min	Nom	Max
Total Thickness	A	2.770	2.890	3.010
Stand Off	A1	0.400	--	0.600
Substrate Thickness	A2	0.940 REF		
Thickness from Substrate Surface to Die Backside	A3	--- REF		
Body Size	D	14.000 BSC		
	E	14.000 BSC		
Ball Diameter		0.600		
Ball Width	b	0.500	---	0.700
Ball Pitch	e	1.000 BSC		
Ball Count	n	169		
Edge Ball Center to Center	D1	12.000 BSC		
	E1	12.000 BSC		
Expose Die Size	D2	---		
	E2	---		
Package Edge Tolerance	aaa	0.100		
Substrate Parallelism	bbb	---		
Top Parallelism	ccc	0.200		
Coplanarity	ddd	0.150		
Ball Offset <Package>	eee	0.250		
Ball Offset <Ball>	fff	0.100		

9 Order Information

9.1 Ordering Part Numbers and Package Markings

Figure 56 shows the ordering part numbering scheme for the 88X5113 device.

Figure 56: Sample Part Number

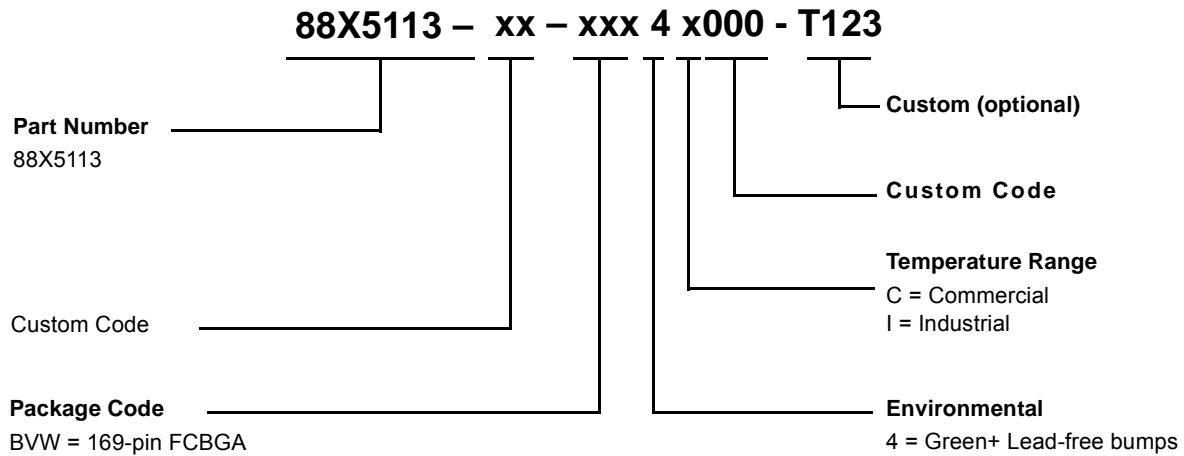

Table 101: 88X5113 Part Order Option

Package Type	Part Order Number
88X5113 169-pin FCBGA 14 × 14 - Commercial	88X5113-XX-BVW4C000
88X5113 169-pin FCBGA 14 × 14 - Industrial	88X5113-XX-BVW4I000

9.1.1 Marking Example

Figure 57 and Figure 58 are examples of the package marking and pin 1 locations for the 88X5113 169-pin FCBGA 14 × 14 commercial and industrial Green package.

Figure 57: 88X5113 169-pin FCBGA Commercial Green Package Marking and Pin 1 Location

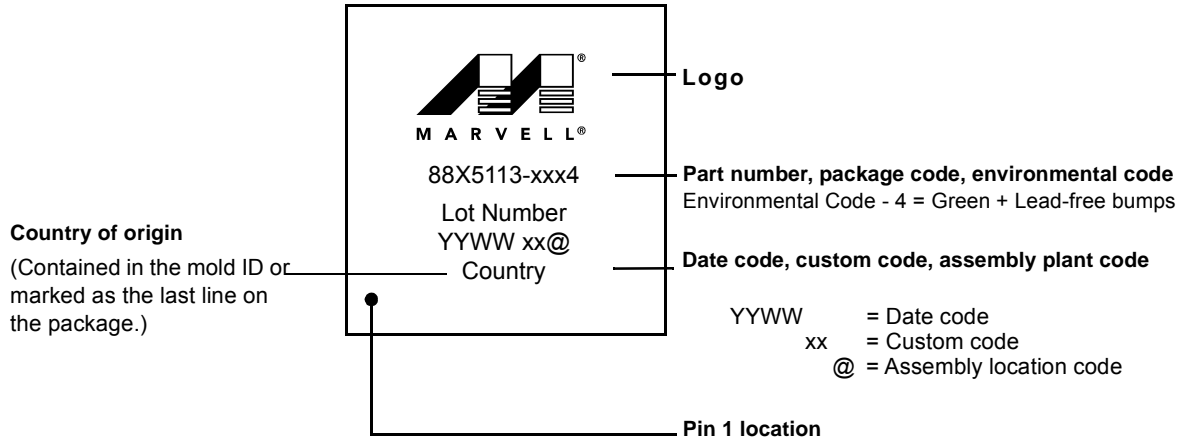

Note: The above example is not drawn to scale. Location of markings is approximate.

Figure 58: 88X5113 169-pin FCBGA Industrial Green Package Marking and Pin 1 Location

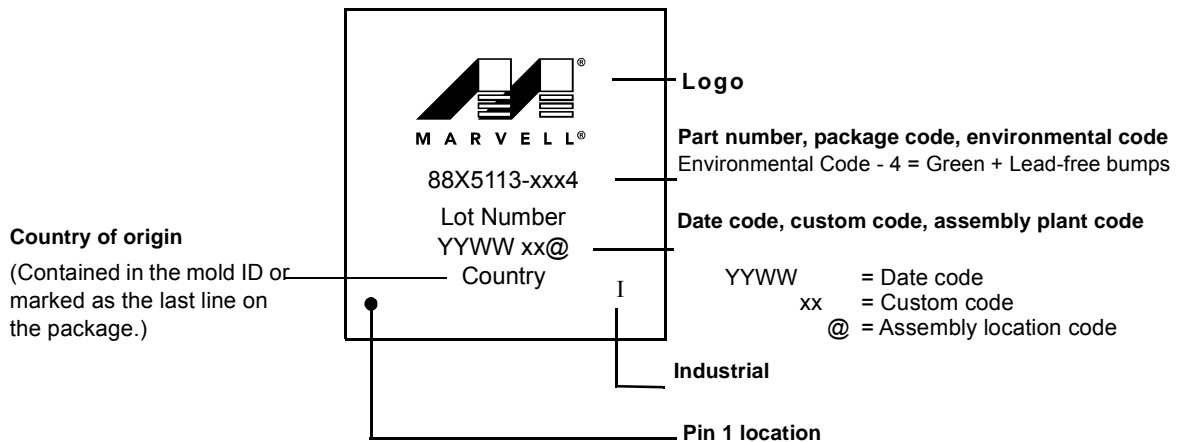

Note: The above example is not drawn to scale. Location of markings is approximate.

A Revision History

Table 102: Revision History

Revision	Date	Section	Detail
Rev. B	July 30, 2018	All applicable	Initial release



Marvell Technology Group
<http://www.marvell.com>

Marvell. Moving Forward Faster

Mouser Electronics

Authorized Distributor

Click to View Pricing, Inventory, Delivery & Lifecycle Information:

[Marvell:](#)

[88X5113-A1-BVW4C000](#)

Компания «Океан Электроники» предлагает заключение долгосрочных отношений при поставках импортных электронных компонентов на взаимовыгодных условиях!

Наши преимущества:

- Поставка оригинальных импортных электронных компонентов напрямую с производств Америки, Европы и Азии, а так же с крупнейших складов мира;
- Широкая линейка поставок активных и пассивных импортных электронных компонентов (более 30 млн. наименований);
- Поставка сложных, дефицитных, либо снятых с производства позиций;
- Оперативные сроки поставки под заказ (от 5 рабочих дней);
- Экспресс доставка в любую точку России;
- Помощь Конструкторского Отдела и консультации квалифицированных инженеров;
- Техническая поддержка проекта, помощь в подборе аналогов, поставка прототипов;
- Поставка электронных компонентов под контролем ВП;
- Система менеджмента качества сертифицирована по Международному стандарту ISO 9001;
- При необходимости вся продукция военного и аэрокосмического назначения проходит испытания и сертификацию в лаборатории (по согласованию с заказчиком);
- Поставка специализированных компонентов военного и аэрокосмического уровня качества (Xilinx, Altera, Analog Devices, Intersil, Interpoint, Microsemi, Actel, Aeroflex, Peregrine, VPT, Syfer, Eurofarad, Texas Instruments, MS Kennedy, Miteq, Cobham, E2V, MA-COM, Hittite, Mini-Circuits, General Dynamics и др.);

Компания «Океан Электроники» является официальным дистрибьютором и эксклюзивным представителем в России одного из крупнейших производителей разъемов военного и аэрокосмического назначения «**JONHON**», а так же официальным дистрибьютором и эксклюзивным представителем в России производителя высокотехнологичных и надежных решений для передачи СВЧ сигналов «**FORSTAR**».



JONHON

«**JONHON**» (основан в 1970 г.)

Разъемы специального, военного и аэрокосмического назначения:

(Применяются в военной, авиационной, аэрокосмической, морской, железнодорожной, горно- и нефтедобывающей отраслях промышленности)

«**FORSTAR**» (основан в 1998 г.)

ВЧ соединители, коаксиальные кабели, кабельные сборки и микроволновые компоненты:

(Применяются в телекоммуникациях гражданского и специального назначения, в средствах связи, РЛС, а так же военной, авиационной и аэрокосмической отраслях промышленности).



Телефон: 8 (812) 309-75-97 (многоканальный)

Факс: 8 (812) 320-03-32

Электронная почта: ocean@oceanchips.ru

Web: <http://oceanchips.ru/>

Адрес: 198099, г. Санкт-Петербург, ул. Калинина, д. 2, корп. 4, лит. А