

White-Rodgers™

50V64-743
Integrated Furnace Control
for Furnaces with Variable Fan Speed
INSTALLATION INSTRUCTIONS

Operator: Save these instructions for future use!

**FAILURE TO READ AND FOLLOW ALL INSTRUCTIONS CAREFULLY BEFORE
INSTALLING OR OPERATING THIS CONTROL COULD CAUSE PERSONAL
INJURY AND/OR PROPERTY DAMAGE.**

DESCRIPTION

The 50V64-743 is a two-stage automatic gas interrupted ignition control employing a microprocessor to continually monitor, analyze, and control the proper operation of the gas burner and inducer, and provide signal for proper operation of variable fan speed timing.

Signals interpreted during continual surveillance of the two-stage thermostat and flame sensing element initiate automatic ignition of the burner, sensing of the flame, and system shutoff during normal operation.

The control incorporates system fault analysis for quick gas flow shutoff, coupled with automatic ignition retry upon sensing a fault correction.

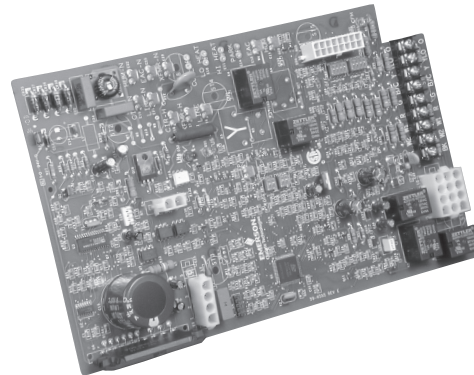

PRECAUTIONS

⚠ GENERAL PRECAUTION

Application of this type of control may cause flame rollout on initial startup and could cause personal injury and/or property damage.

Replace only with exact model number, including dash number. Failure to use exact replacement control could cause personal injury and/or property damage.

If in doubt about whether your wiring is millivolt, line, or low voltage, have it inspected by a qualified heating and air conditioning contractor or licensed electrician.

Do not exceed the specification ratings.

All wiring must conform to local and national electrical codes and ordinances.

This control is a precision instrument, and should be handled carefully. Rough handling or distorting components could cause the control to malfunction.

⚠ CAUTION

To prevent electrical shock and/or equipment damage, disconnect electric power to system at main fuse or circuit breaker box until installation is complete.

This control is not intended for use in locations where it may come in direct contact with water. Suitable protection must be provided to shield the control from exposure to water (dripping, spraying, rain, etc.).

Label all wires prior to disconnection when servicing controls. Wiring errors can cause improper and dangerous operation.

Following installation or replacement, follow appliance manufacturers' recommended installation/service instructions to insure proper operation.

Do not use on circuits exceeding specified voltage. Higher voltage will damage control and could cause shock or fire hazard.

CONTENTS

Description	1
Precautions	1
Specifications	2
Operation.....	2
Installation	5
Mounting & Wiring	

⚠ WARNING

Do not short out terminals on gas valve or primary control to test. Short or incorrect wiring will damage thermostat and could cause personal injury and/or property damage.

SPECIFICATIONS

ELECTRICAL RATINGS [@ 77°F (25°C)]:

Input Voltage: 25 VAC, 60 Hz

Max. Input Current @ 25 VAC: 525mA + MV

Relay Load Ratings:

Gas Valve Relay: 1.5 amp @ 25 VAC, 60 Hz, 0.6 pf

Ignitor: 2.0 amp @ 80VAC, 60 Hz - resistive

Humidifier Relay: 1.0 Amp @ 120 VAC, 60 Hz.

Electronic Air Cleaner Relay: 1.0 Amp, @ 120 VAC, 60 Hz

Flame Current Requirements:

Minimum current to insure flame detection: 1 µA DC*

Maximum current for non-detection: 0.1 µA DC*

Maximum allowable leakage resistance: 100 M ohms

*Measured with a DC microammeter in the flame probe lead

OPERATING TEMPERATURE RANGE:

-40° to 175°F (-40° to 80°C)

HUMIDITY RANGE:

5% to 95% relative humidity (non-condensing)

Timing Specs: (@ 60 Hz**)

maximum

Flame Establishing Time: 0.8 sec

Flame Failure Response Time: 2.0 sec

Gases Approved: Natural, Manufactured, Mixed, Liquid Petroleum, and LP Gas Air Mixtures are all approved for use.

TIMING SPECIFICATIONS

(All times are in seconds, unless noted otherwise)

50V64

PRE-PURGE	0
TRIAL FOR IGNITION PERIOD	5
IGNITION ACTIVATION PERIOD	2
RETRIES	2 times
VALVE SEQUENCE PERIOD	15
INTERPURGE	60
POST-PURGE	5
LOCKOUT TIME	258
HEAT DELAY-TO-FAN ON	45
HEAT DELAY-TO-FAN OFF*	60/100/ 140/180
COOL DELAY-TO-FAN OFF*	N/A
ELECTRONIC AIR CLEANER	YES
HUMIDIFIER	YES

* These times will vary depending on option switch position. See OPERATION section for further information.

OPERATION

OPTION SWITCHES

Switches on the 50V64-743 control are used to control functions of the circulator blower. Switches labeled SW3 and SW4 control the circulator blower speed. Switch labeled SW2 controls the heat delay-to-fan-off period. The following table shows the time periods that will result from the various switch positions.

OPTION SWITCH POSITIONS

HEAT delay-to-fan-off (SW2):	Set switch #	
	1	2
60 sec.	On	Off
100 sec.	On	On
140 sec.	Off	On
180 sec.	Off	Off

The dip switch settings for this control may be different from the control being replaced. Please set the switches for the delay period according to the chart above.

If W1 and W2 are tied together, the time delay of second stage is based on the switch settings of SW1, per the following table.

SW1 SWITCH POSITIONS

TIME	Set switch # SW1-1	Set switch # SW1-2
1/2 Min	On	Off
5 Min	Off	On
10 Min	Off	Off
15 Min	On	On

HEAT MODE

In a typical system, a call for **first stage** heat is initiated by closing the W1 thermostat contacts. The Humidifier output is energized and the inducer blower is enabled at low speed. The control waits for the stage 1 pressure switch to close. When the pressure switch closes the silicon nitride ignitor is powered.

This control has an adaptive algorithm that reduces the ignitor temperature to slightly greater than the minimum temperature required to ignite gas in each particular application. The control measures the line voltage and determines an initial ignitor temperature setting based on the measurement. After each successful ignition, the control lowers the ignitor temperature slightly for the next ignition attempt. The control continues to lower the ignitor temperature until ignition does not occur, and the control goes into retry mode. For the second attempt to ignite gas within the same call for heat, the control increases the ignitor temperature to the value it was on the previous successful ignition. After ignition is successful, the control sets the ignition temperature at this value. The control is constantly making adjustments to the ignitor modulation routine to compensate for changes in the line voltage. The control will relearn after power interruptions.

The Silicon Nitride ignitor manufactured by White-Rodgers must be used. These ignitors are specially designed to operate with the adaptive ignition routine used by the control to ensure the most efficient ignitor temperature.

At the end of the ignitor warm-up time, the first stage of the two-stage manifold gas valve is energized (low fire). Flame must be detected within 5 seconds. If flame is detected, the 45 second delay-to-fan-on period begins. After the delay-to-fan-on period ends, the circulator enable, (pin 15 on the 16-pin connector is the “E” output to the circulator) and air cleaner are energized.

A call for **second stage** heat (W1 and W2) after a call for first stage heat will activate a 30-second 2nd stage delay. Following the 30-second delay, the inducer motor is driven at high speed. The control checks the 2nd stage pressure switch. When the pressure switch closes, the 2nd stage gas valve turns on and the circulator is enabled at high speed (“E” remains energized any time the circulator is on).

When the second stage of the thermostat is satisfied, the inducer motor is reduced to low speed, and the 2nd stage gas valve and high circulator speed are de-energized.

When the first stage of the thermostat is satisfied, the gas valve is de-energized and the heat delay-to-fan-off timing begins. The inducer will postpurge for an additional 5 seconds. When this time is expired, the inducer and humidifier will de-energize. Upon completion of the heat delay-to-fan-off period, the circulator and air cleaner are de-energized.

If flame is not detected during the trial-for-ignition period, the gas valve is de-energized, the ignitor is turned off, and the control goes into the “retry” sequence.

The “retry” sequence starts with a 60-second interpurge, enabling the inducer at low speed for 60 seconds following an unsuccessful ignition attempt (flame not detected). After this wait, the ignition sequence is restarted. If this ignition attempt is unsuccessful, one more retry will be made before the control goes into system lockout.

If flame is detected, then lost, the control will repeat the initial ignition sequence for a total of ten “recycles”. After ten unsuccessful attempts to sustain flame, the control will go into system lockout.

During burner operation, a momentary loss of power of 250 milliseconds or longer will de-energize the main gas valve. When power is restored, the gas valve will remain de-energized and a restart of the ignition sequence will begin immediately.

A momentary loss of gas supply, flame blowout, or a shorted or open condition in the flame probe circuit will be sensed within 2 seconds. The gas valve will de-energize and the control will restart the ignition sequence. Recycles will begin and the burner will operate normally if the gas supply returns, or the fault condition is corrected, before the last ignition attempt. Otherwise, the control will go into system lockout.

If the control has gone into system lockout, it may be possible to reset the control by a momentary power interruption of five seconds or longer. Refer to **PRECAUTIONARY, SYSTEM LOCKOUT, AND DIAGNOSTIC FEATURES**.

COOL MODE

In a typical system, a call for cool is initiated by closing the thermostat contacts. This energizes the compressor, circulator “E” output and air cleaner. After the thermostat is satisfied, the compressor is de-energized and the optional cool mode delay-to-fan-off period begins. After the optional delay-to-fan-off period ends, the circulator “E” output and air cleaner are de-energized.

MANUAL FAN ON MODE

If the thermostat fan switch is moved to the ON position, the circulator “E” output and air cleaner are energized. When the fan switch is returned to the AUTO position, the circulator “E” output and air cleaner are de-energized.

PRECAUTIONARY, SYSTEM LOCKOUT, AND DIAGNOSTIC FEATURES

PRECAUTIONARY FEATURES

The following precautionary features are built into the control.

1. If the high temperature limit or flame rollout sensor open at any time, the gas valve is de-energized.
2. During a call for heat cycle, if flame is sensed at any time when the gas valve is de-energized, the circulation “E” output and inducer fan are energized at low speed in conjunction with system lockout.
3. If the high limit (and/or auxiliary limit) switch(es) open at any time during a call for heat, the circulator blower and inducer fan are energized at low speed.

SYSTEM LOCKOUT FEATURES

When system lockout occurs, the gas valve is de-energized, the circulator “E” output and the inducer blower are energized at low speed. The diagnostic indicator light will flash to indicate system status. **(System lockout will never override the precautionary features described above.)**

To reset the control after system lockout, do one of the following:

1. Interrupt the call for heat at the thermostat for at least one second and less than twenty seconds (if flame is sensed

OPERATION

with the gas valve de-energized, interrupting the call for heat at the thermostat will **not** reset the control).

- Interrupt the 24 VAC power at the control for at least five seconds. You may also need to reset the flame rollout sensor switch.
- After one hour in lockout, the control will automatically reset itself.

DIAGNOSTIC FEATURES

The control continuously monitors its own operation and the operation of the system. If a failure occurs, the red LED on the control will flash a failure code. **If the Red and Green "status" LED's are on solid, the 5 amp replaceable fuse is bad. If the fuse is good or the Red LED is on by itself, the entire control should be replaced, as the control is not field-repairable.**

If the sensed failure is in the system (external to the control), the red LED will flash in the following flash-pause sequences to indicate failure status (each flash will last approximately 0.25 seconds, and each pause will last approximately 2 seconds).

- | | |
|-----------------------|----------------------------------|
| 2 flashes, then pause | Retries or recycles exceeded |
| 3 flashes, then pause | Inducer or pressure switch error |
| 4 flashes, then pause | Open limit or rollout switch |

5 flashes, then pause

Flame sense when no flame should be present

6 flashes, then pause

Line reverse polarity or ignitor circuit error

7 flashes, then pause

Gas valve circuit error

8 flashes, then pause

Weak flame

9 flashes, then pause

Open inducer limit error

The Green and Red LED's will also flash once for 1 second at power-up.

FAULT CODE RETRIEVAL

Two seconds after the power ON, the control shall flash the last four error codes that have occurred over the last 14 days on the red LED. The control will flash the newest error first and the oldest error last with a two-second pause between flash codes. Solid LED error codes will not be displayed. The green STATUS LED shall remain ON while the red LED flashes the error codes.

The last four fault codes can be erased from memory by powering up with **G** energized and then toggling **W1** three times within eight seconds. **W1** must be toggled after the power ON reset for approximately one second each time. The control will acknowledge by turning on the red LED and green STATUS LED for two seconds.

INSTALLATION

MOUNTING AND WIRING

WARNING

Do not use on circuits exceeding specified voltage. Higher voltage will damage control and could cause shock or fire hazard.

CAUTION

To prevent electrical shock and/or equipment damage, disconnect electric power to system at main fuse or circuit breaker box until installation is complete. Failure to earth ground the appliance or reversing the neutral and hot wire connection to the line can cause shock hazard.

Shut off main gas to heating system until installation is complete.

Route and secure all wiring as far from flame as practical to prevent fire and/or equipment damage.

Replace 50V50 control as a unit - no user serviceable parts.

NOTE

All wiring should be installed according to local and national electrical codes and ordinances.

The 50V64 control may be mounted on any convenient surface using the four standoffs provided.

The control must be secured to an area that will experience a minimum of vibration and remain below the maximum ambient temperature rating of 175°F. The control is approved for minimum ambient temperatures of -40°F.

Any orientation is acceptable.

Refer to the wiring diagram and wiring table when connecting the 50V64 control to other components of the system.

UL approved, 105°C rated 18 gauge min., stranded, $\frac{2}{64}$ " thick insulation wire is recommended for all low voltage safety circuit connections. Refer to 50V64 control specification sheet for recommended terminals to mate with those on the control.

UL approved, 105°C rated 16 gauge min., stranded, $\frac{4}{64}$ " thick insulation wire is recommended for all line voltage connections. Refer to 50V64 control specification sheet for recommended terminals to mate with those on the control.

Following installation or replacement, follow appliance manufacturer's recommended installation or service instructions to insure proper operation.

TYPICAL SYSTEM WIRING TABLE

50V64 TERMINAL	TYPE	SYSTEM COMPONENT CONNECTION
W1 W2 G R B/C YLO Y BK O	9-screw terminal block	First stage call for heat Second stage call for heat Input for fan operation 24 VAC transformer (HIGH side) 24 VAC transformer (LOW side) First stage call for cool Second stage call for cool Humidistat enable H/P or cooling mode
MVH (3) MV COM (8) HLI (2) HLO (9) TR (11) MV (4) TH (7) GND (5) PS2 (6) PS0 (1) IL1 (10) PS1 (12)	12-pin connector	Gas valve second stage Gas valve ground High limit input High limit output 24 VAC transformer (low voltage COMMON side) Gas valve first stage 24 VAC transformer (low voltage HIGH side) MUST BE RELIABLY GROUNDED TO CHASSIS 2nd stage pressure switch Pressure switch output Inducer limit input 1st stage pressure switch
E11-1 E11-2 E11-3 E11-4 E11-5 E11-6 E11-7 E11-8 E11-9 E11-10 E11-11 E11-12 E11-13 E11-14 E11-15 E11-16	16-pin connector	24 VAC Common Low heat speed select, output to circulator blower 24 VAC Common Delay tap, output to circulator Cool tap, output to circulator YLO, output to circulator Adjust tap, output to circulator 24 VAC Common O, output to circulator Humidistat, output to circulator Heat tap, output to circulator 24 VAC W2, output to circulator Y, output to circulator G, output to circulator Green CFM indicator
IGN-H IGN-N	2-pin connector	Ignitor output Ignitor common
IND 01 (1) IND 02 (2) IND 03 (3) GRND (4)	4-pin connector	Inducer 01 Inducer 02 Inducer 03 Inducer ground
LINE-N	spade terminal*	Input voltage (120 VAC) neutral side
XFMR-N	spade terminal*	24 VAC transformer line voltage neutral side
CIR-N	spade terminal*	Circulator blower neutral side
XFMR-H	spade terminal*	24 VAC transformer line voltage hot side
CIR-H	spade terminal*	Circulator blower hot side
LINE	spade terminal*	Input voltage (120 VAC) HOT SIDE
HUM	spade terminal*	Humidifier hot side
EAC	spade terminal*	Electronic Air Cleaner hot side
HUM - N	spade terminal*	Humidifier neutral side
EAC - N	spade terminal*	Electronic Air Cleaner neutral side
FP	spade terminal*	Flame probe**

* Spade terminals are 0.25" x 0.032"

** maximum recommended flame probe wire length is 36 inches.

TYPICAL SYSTEM WIRING DIAGRAM

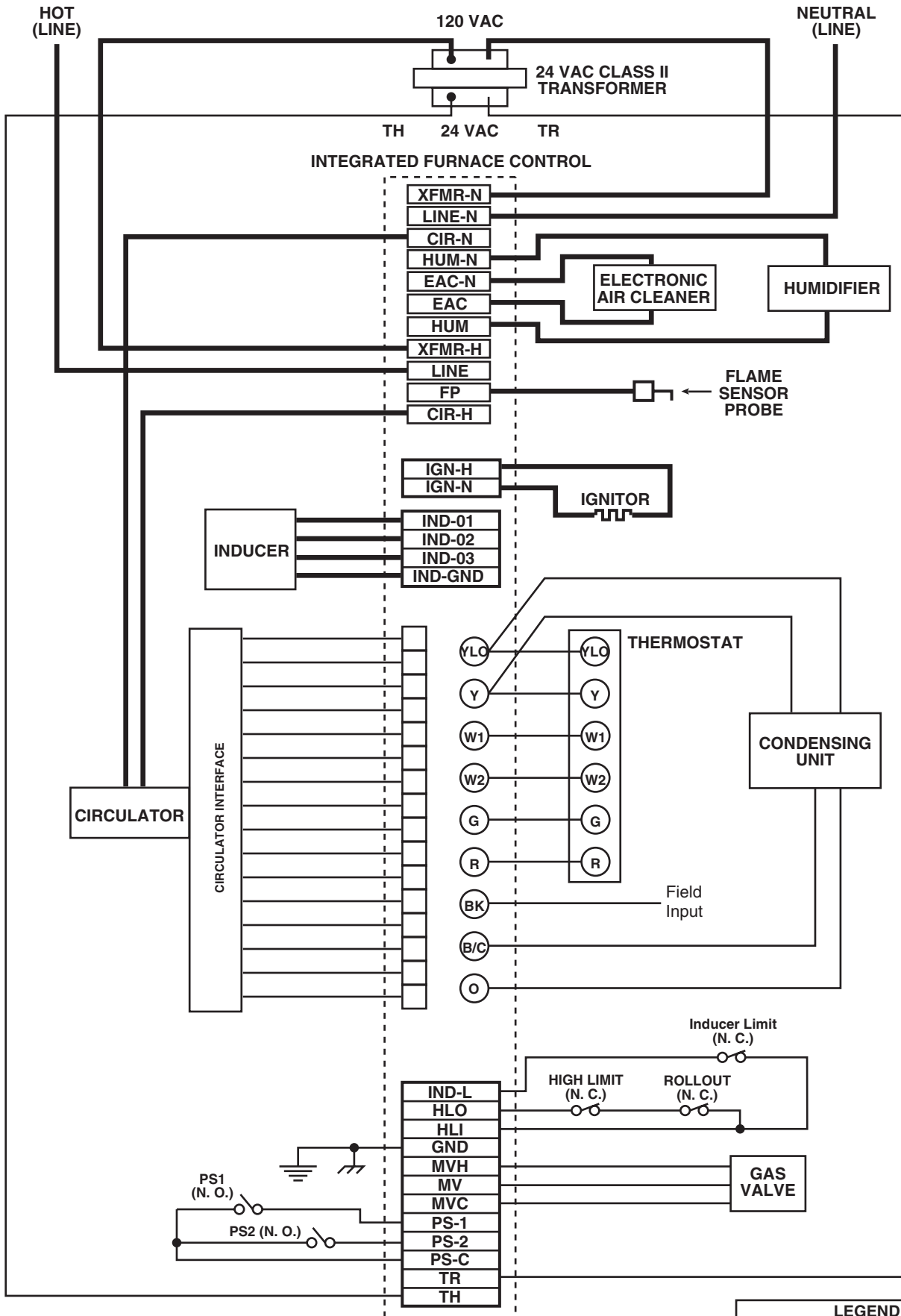

NOTES

White-Rodgers is a business
of Emerson Electric Co.

The Emerson logo is a
trademark and service mark
of Emerson Electric Co.

White-Rodgers™

www.white-rodgers.com
www.emersonclimate.com



Компания «Океан Электроники» предлагает заключение долгосрочных отношений при поставках импортных электронных компонентов на взаимовыгодных условиях!

Наши преимущества:

- Поставка оригинальных импортных электронных компонентов напрямую с производств Америки, Европы и Азии, а так же с крупнейших складов мира;
- Широкая линейка поставок активных и пассивных импортных электронных компонентов (более 30 млн. наименований);
- Поставка сложных, дефицитных, либо снятых с производства позиций;
- Оперативные сроки поставки под заказ (от 5 рабочих дней);
- Экспресс доставка в любую точку России;
- Помощь Конструкторского Отдела и консультации квалифицированных инженеров;
- Техническая поддержка проекта, помощь в подборе аналогов, поставка прототипов;
- Поставка электронных компонентов под контролем ВП;
- Система менеджмента качества сертифицирована по Международному стандарту ISO 9001;
- При необходимости вся продукция военного и аэрокосмического назначения проходит испытания и сертификацию в лаборатории (по согласованию с заказчиком);
- Поставка специализированных компонентов военного и аэрокосмического уровня качества (Xilinx, Altera, Analog Devices, Intersil, Interpoint, Microsemi, Actel, Aeroflex, Peregrine, VPT, Syfer, Eurofarad, Texas Instruments, MS Kennedy, Miteq, Cobham, E2V, MA-COM, Hittite, Mini-Circuits, General Dynamics и др.);

Компания «Океан Электроники» является официальным дистрибьютором и эксклюзивным представителем в России одного из крупнейших производителей разъемов военного и аэрокосмического назначения «JONHON», а так же официальным дистрибьютором и эксклюзивным представителем в России производителя высокотехнологичных и надежных решений для передачи СВЧ сигналов «FORSTAR».



JONHON

«JONHON» (основан в 1970 г.)

Разъемы специального, военного и аэрокосмического назначения:

(Применяются в военной, авиационной, аэрокосмической, морской, железнодорожной, горно- и нефтедобывающей отраслях промышленности)

«FORSTAR» (основан в 1998 г.)

ВЧ соединители, коаксиальные кабели, кабельные сборки и микроволновые компоненты:

(Применяются в телекоммуникациях гражданского и специального назначения, в средствах связи, РЛС, а так же военной, авиационной и аэрокосмической отраслях промышленности).



Телефон: 8 (812) 309-75-97 (многоканальный)

Факс: 8 (812) 320-03-32

Электронная почта: ocean@oceanchips.ru

Web: <http://oceanchips.ru/>

Адрес: 198099, г. Санкт-Петербург, ул. Калинина, д. 2, корп. 4, лит. А