

## RS-232/485/422 Serial Transceiver with Internal Termination and Wide Output Swing

### Description

The **XR34350** is an advanced multiprotocol transceiver supporting RS-232, RS-485, and RS-422 serial standards in a 40-pin QFN package. Integrated cable termination and four configuration modes allow all three protocols to be used interchangeably over a single cable or connector with no additional switching components. Full operation requires only four external charge pump capacitors.

The RS-485/RS-422 modes feature one driver and one receiver (1Tx/1Rx) in both half and full duplex configurations. The RS-232 mode (3Tx/5Rx) provides full support of all eight signals commonly used with the DB9 RS-232 connector. A dedicated diagnostic loopback mode is also provided.

The high speed drivers operate up to 20Mbps in RS-485/RS-422 modes, and up to 1Mbps in RS-232 mode. All drivers can be slew limited to 250kbps in any mode to minimize Electromagnetic Interference (EMI).

All transmitter outputs and receiver inputs feature robust Electrostatic Discharge (ESD) protection to  $\pm 15\text{kV}$  IEC-61000-4-2 air gap,  $\pm 8\text{kV}$  IEC-61000-4-2 contact, and  $\pm 15\text{kV}$  Human Body Model (HBM). Each receiver output has full fail-safe protection to avoid system lockup, oscillation, or indeterminate states by defaulting to logic-high output level when the inputs are open, shorted, or terminated but undriven. No external biasing resistors are required.

The RS-232 receiver inputs include a  $5\text{k}\Omega$  pull-down to ground. The RS-485/RS-422 receiver inputs are high impedance ( $>96\text{k}\Omega$  when termination is disabled), allowing up to 256 devices on a single communication bus (1/8th unit load).

The XR34350 operates from a single power supply, either 3.3V or 5V, with low idle current (2mA typical in all modes). The shutdown mode consumes less than  $10\mu\text{A}$  for low power standby operation.

### Typical Application

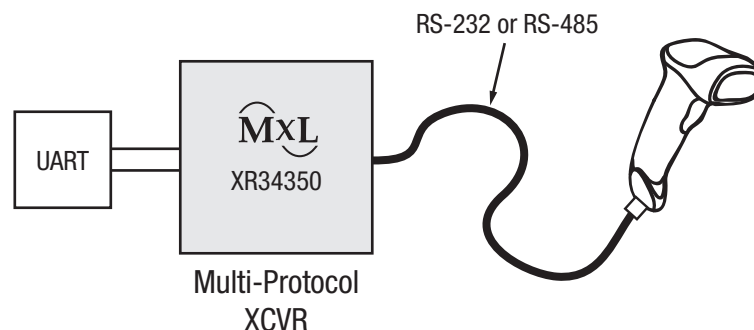

Figure 1: Typical Application

### FEATURES

- Rx enabled during Tx short-circuit condition
- Pin selectable cable termination
- No external resistors required for RS-485/RS-422 termination and biasing
- 3.3V or 5V single supply operation
- Robust ESD protection on bus pins
  - $\pm 15\text{kV}$  IEC 61000-4-2 (air gap)
  - $\pm 8\text{kV}$  IEC 61000-4-2 (contact)
  - $\pm 15\text{kV}$  (HBM)
- Max data rate of 20Mbps in RS-485/RS-422 modes and up to 1Mbps in RS-232 modes
- Pin selectable 250kbps slew limiting
- 3 drivers, 5 receivers RS-232/V.28
- 1 driver, 1 receiver RS-485/RS-422
- High swing RS-232 driver outputs ( $\pm 10.0\text{V}$  no load)
  - Full and half duplex configuration
  - 1/8th unit load, up to 256 receivers on bus
- RS-485/RS-422 enhanced failsafe for open, shorted, or terminated but idle inputs
- Space saving 40-pin 6mm x 6mm QFN package
- Pin compatible with SP339E and SP338E

### APPLICATIONS

- Dual protocol serial ports (RS-232 or RS-485/RS-422)
- Industrial and process control equipment
- Point-of-sale equipment
- HVAC controls equipment
- Building security and automation equipment

Ordering Information - [Back Page](#)

## Absolute Maximum Ratings

Stresses beyond the limits listed below may cause permanent damage to the device. Exposure to any Absolute Maximum Rating condition for extended periods may affect device reliability and lifetime.

Supply voltage $V_{CC}$ .....	-0.3V to 6.0V
Receiver input voltage (from ground) .....	$\pm 18V$
Driver output voltage (from ground).....	$\pm 18V$
Short-circuit duration, Tx out to ground .....	Continuous
Voltage at TTL input pins.....	-0.3V to ( $V_{CC} + 0.5V$ )
Storage temperature range .....	-65°C to 150°C
Lead temperature (soldering 10 seconds).....	300°C
Power dissipation 40-pin QFN (derate 17mW/°C above 70°C) .....	500mW

## Operating Conditions

Supply voltage $V_{CC}$ .....	3.135V to 5.25V
Operating temperature range .....	-40° to 85°C

## ESD Ratings

Human Body Model (HBM), Tx and Rx pins.....	$\pm 15kV$
Human Body Model (HBM), all other pins .....	$\pm 4kV$
IEC 61000-4-2 (contact), Tx and Rx pins .....	$\pm 8kV$
IEC 61000-4-2 (air gap), Tx and Rx pins.....	$\pm 15kV$

## Electrical Characteristics

Unless otherwise noted:  $V_{CC} = 3.3V \pm 5\%$  or  $5.0V \pm 5\%$ ,  $C1$  to  $C4 = 0.1\mu F$ ;  $T_A = T_{MIN}$  to  $T_{MAX}$ . Typical values are at  $V_{CC} = 3.3V$ ,  $T_A = 25^\circ C$ .

Symbol	Parameter	Conditions	Min	Typ	Max	Units
DC Characteristics						
$I_{CC}$	Supply current, RS-232	No load, idle inputs		2	8	mA
	Supply current, RS-485	No load, idle inputs		2	8	mA
	$V_{CC}$ shutdown current	Enable = 0V		1	10	$\mu A$
Transmitter and Logic Input Pins: Pins 3, 4, 6, 11, 12, 14, 15, 17 to 19						
$V_{IH}$	Logic input voltage High	$V_{CC} = 3.3V$	2.0			V
		$V_{CC} = 5.0V$	2.4			V
$V_{IL}$	Logic input voltage Low				0.8	V
$I_{IL}$	Logic input leakage current low	Input low, $V_{IN} = 0V$			1	$\mu A$
$I_{IH}$	Logic input leakage current high	Input high, $V_{IN} = V_{CC}$ , pins 3, 4 and 6			1	$\mu A$
$I_{PD}$	Logic input pull-down current	Input high $V_{IN} = V_{CC}$ , pins 11, 12, 14, 15, 17 to 19			50	$\mu A$
$V_{HYS}$	Logic input hysteresis			200		mV
Receiver Outputs: Pins 1, 2, 5, 7, 8						
$V_{OH}$	Receiver output voltage high	$I_{OUT} = -1.5mA$	$V_{CC} - 0.6$			V
$V_{OL}$	Receiver output voltage low	$I_{OUT} = 2.5mA$			0.4	V
$I_{OSS}$	Receiver output short-circuit current	$0 \leq V_O \leq V_{CC}$		$\pm 20$	$\pm 60$	mA
$I_{OZ}$	Receiver output leakage current	$0 \leq V_O \leq V_{CC}$ , receivers disabled		$\pm 0.1$	$\pm 1$	$\mu A$
Single-Ended Receiver Inputs, RS-232						
$V_{IN}$	Input voltage range		-15		15	V
$V_{IL}$	Input threshold low	$V_{CC} = 3.3V$	0.6	1.2		V
		$V_{CC} = 5.0V$	0.8	1.5		V
$V_{IH}$	Input threshold high	$V_{CC} = 3.3V$		1.5	2.0	V
		$V_{CC} = 5.0V$		1.8	2.4	V
$V_{HYS}$	Input hysteresis			0.3		V
$R_{IN}$	Input resistance	$-15V \leq V_{IN} \leq 15V$	3	5	7	k $\Omega$
Single-Ended Driver Outputs, RS-232						
$V_O$	Output voltage	$V_{CC} = 5.0V$ , output loaded 3k $\Omega$ to GND		$\pm 8.6$		V
		$V_{CC} = 5.0V$ , unloaded output			$\pm 10.0$	V
		$V_{CC} = 3.3V$ , output loaded 3k $\Omega$ to GND	$\pm 5.0$	$\pm 5.5$		V
		$V_{CC} = 3.3V$ , unloaded output			$\pm 7.0$	V
$I_{SC}$	Short-circuit current	$V_O = 0V$			$\pm 60$	mA
$R_{OFF}$	Power off impedance	$V_{CC} = 0V$ , $V_O = \pm 2V$	300	10M		$\Omega$

## Electrical Characteristics (Continued)

Unless otherwise noted:  $V_{CC} = 3.3V \pm 5\%$  or  $5.0V \pm 5\%$ ,  $C1$  to  $C4 = 0.1\mu F$ ;  $T_A = T_{MIN}$  to  $T_{MAX}$ . Typical values are at  $V_{CC} = 3.3V$ ,  $T_A = 25^\circ C$ .

Symbol	Parameter	Conditions	Min	Typ	Max	Units
Differential Receiver Inputs, RS-485/RS-422						
$R_{IN}$	Receiver input resistance	$TERM = 0V$ , $-7V \leq V_{IN} \leq 12V$	96			k $\Omega$
$V_{TH}$	Receiver differential threshold voltage		-200	-125	-50	mV
$\Delta V_{TH}$	Receiver input hysteresis	$V_{CM} = 0V$		25		mV
$I_{IN}$	Receiver input current	$V_{IN} = 12V$			125	$\mu A$
		$V_{IN} = -7V$			-100	$\mu A$
$R_{TERM}$	Termination resistance	$TERM = V_{CC}$ , <a href="#">Figure 6</a> , $-7V \leq V_{CM} \leq 12V$	100	120	155	$\Omega$
		$TERM = V_{CC}$ , <a href="#">Figure 6</a> , $V_{CM} = 0V$	100	120	140	$\Omega$
Differential Driver Outputs, RS-485/RS-422						
$V_{OD}$	Differential driver output	$R_L = 100\Omega$ , RS-422, <a href="#">Figure 7</a>	2		$V_{CC}$	V
		$R_L = 54\Omega$ , RS-485, <a href="#">Figure 7</a>	1.5		$V_{CC}$	V
		$-7V \leq V_{CM} \leq 12V$ , <a href="#">Figure 8</a>	1.5		$V_{CC}$	V
		No load			$V_{CC}$	V
$\Delta V_{OD}$	Change in magnitude of differential output voltage		-0.2		0.2	V
$V_{CM}$	Driver common mode output voltage	$R_L = 54\Omega$ or $100\Omega$ , <a href="#">Figure 7</a>			3	V
$\Delta V_{CM}$	Change in magnitude of common mode output voltage				0.2	V
$I_{OSD}$	Driver output short-circuit current	$-7V \leq V_O \leq 12V$ , <a href="#">Figure 9</a>	-250		250	mA
$I_O$	Driver output leakage current	$DIR1 = 0V$ in Mode 11, or Enable = $0V$ , $V_O = 12V$ , $V_{CC} = 0V$ or $5.25V$			100	$\mu A$
		$DIR1 = 0V$ in Mode 11, or Enable = $0V$ , $V_O = -7V$ , $V_{CC} = 0V$ or $5.25V$	-100			$\mu A$

## Timing Characteristics

Unless otherwise noted:  $V_{CC} = 3.3V \pm 5\%$  or  $5.0V \pm 5\%$ ,  $C_1$  to  $C_4 = 0.1\mu F$ ;  $T_A = T_{MIN}$  to  $T_{MAX}$ . Typical values are at  $V_{CC} = 3.3V$ ,  $T_A = 25^\circ C$ .

Symbol	Parameter	Conditions	Min	Typ	Max	Units
All Modes						
$t_{ENABLE}$	Enable from shutdown			1000		ns
$t_{SHUTDOWN}$	Enable to shutdown			1000		ns
RS-232, Data Rate = 250kbps, SLEW = $V_{CC}$ , One Transmitter Switching						
	Maximum data rate	$R_L = 3k\Omega$ , $C_L = 1000pF$	250			kbps
$t_{RHL}$ , $t_{RLH}$	Receiver propagation delay	$C_L = 150pF$ , <a href="#">Figure 10</a>		100		ns
$ t_{RHL} - t_{RLH} $	Receiver propagation delay skew				100	ns
$t_{DHL}$ , $t_{DLH}$	Driver propagation delay	$R_L = 3k\Omega$ , $C_L = 2500pF$ , <a href="#">Figure 11</a>		1400		ns
$ t_{DHL} - t_{DLH} $	Driver propagation delay skew				600	ns
$t_{SHL}$ , $t_{SLH}$	Transition region slew rate from 3.0V to -3.0V or -3.0V to 3.0V	$V_{CC} = 3.3V$ , $R_L = 3k\Omega$ to $7k\Omega$ , $C_L = 150pF$ to $2500pF$ , <a href="#">Figure 11</a>	4		30	V/ $\mu s$
		$V_{CC} = 3.3V$ , $R_L = 3k\Omega$ to $7k\Omega$ , $C_L = 150pF$ to $2500pF$ , $T_A = 25^\circ C$ , <a href="#">Figure 11</a>	6		30	V/ $\mu s$
RS-232, Data Rate = 1Mbps, SLEW = 0V, One Transmitter Switching						
	Maximum data rate	$R_L = 3k\Omega$ , $C_L = 250pF$	1			Mbps
$t_{RHL}$ , $t_{RLH}$	Receiver propagation delay	$C_L = 150pF$ , <a href="#">Figure 10</a>		100		ns
$ t_{RHL} - t_{RLH} $	Receiver propagation delay skew				100	ns
$t_{DHL}$ , $t_{DLH}$	Driver propagation delay	$R_L = 3k\Omega$ , $C_L = 1000pF$ , <a href="#">Figure 11</a>		300		ns
$ t_{DHL} - t_{DLH} $	Driver propagation delay skew				150	ns
$t_{SHL}$ , $t_{SLH}$	Transition region slew rate from 3.0V to -3.0V or -3.0V to 3.0V	$V_{CC} = 3.3V$ , $R_L = 3k\Omega$ to $7k\Omega$ , $C_L = 150pF$ to $1000pF$ , <a href="#">Figure 11</a>	15		150	V/ $\mu s$
		$V_{CC} = 3.3V$ , $R_L = 3k\Omega$ to $7k\Omega$ , $C_L = 150pF$ to $1000pF$ , $T_A = 25^\circ C$ , <a href="#">Figure 11</a>	24		150	V/ $\mu s$

## Timing Characteristics (Continued)

Unless otherwise noted:  $V_{CC} = 3.3V \pm 5\%$  or  $5.0V \pm 5\%$ ,  $C_1$  to  $C_4 = 0.1\mu F$ ;  $T_A = T_{MIN}$  to  $T_{MAX}$ . Typical values are at  $V_{CC} = 3.3V$ ,  $T_A = 25^\circ C$ .

Symbol	Parameter	Conditions	Min	Typ	Max	Units
RS-485/RS-422, Data Rate = 250kbps, SLEW = $V_{CC}$ , One Transmitter Switching						
	Maximum data rate	$R_L = 54\Omega$ , $C_L = 50pF$	250			kbps
$t_{RPHL}$ , $t_{RPLH}$	Receiver propagation delay	$C_L = 15pF$ , <a href="#">Figure 12</a>		50	150	ns
$ t_{RPHL} - t_{RPLH} $	Receiver propagation delay skew				20	ns
$t_{DPHL}$ , $t_{DPLH}$	Driver propagation delay	$R_L = 54\Omega$ , $C_L = 50pF$ , <a href="#">Figure 13</a>		500	1000	ns
$ t_{DPHL} - t_{DPLH} $	Driver propagation delay skew				100	ns
$t_{DR}$ , $t_{DF}$	Driver rise and fall time		300	650	1200	ns
$t_{RZH}$ , $t_{RZL}$	Receiver output enable Time	$C_L = 15pF$ , <a href="#">Figure 14</a>			200	ns
$t_{RHZ}$ , $t_{RLZ}$	Receiver output disable time				200	ns
$t_{DZH}$ , $t_{DZL}$	Driver output enable time	$R_L = 500\Omega$ , $C_L = 50pF$ , <a href="#">Figure 15</a>			1000	ns
$t_{DZH}$ , $t_{DLZ}$	Driver output disable time				200	ns
RS-485/RS-422, Data Rate = 20Mbps, SLEW = 0V, One Transmitter Switching						
	Maximum data rate	$R_L = 54\Omega$ , $C_L = 50pF$	20			Mbps
$t_{RPHL}$ , $t_{RPLH}$	Receiver propagation delay	$C_L = 15pF$ , <a href="#">Figure 12</a>		50	150	ns
$ t_{RPHL} - t_{RPLH} $	Receiver propagation delay skew				10	ns
$t_{DPHL}$ , $t_{DPLH}$	Driver propagation delay	$R_L = 54\Omega$ , $C_L = 50pF$ , <a href="#">Figure 13</a>		30	100	ns
$ t_{DPHL} - t_{DPLH} $	Driver propagation delay skew				10	ns
$t_{DR}$ , $t_{DF}$	Driver rise and fall time			10	20	ns
$t_{RZH}$ , $t_{RZL}$	Receiver output enable Time	$C_L = 15pF$ , <a href="#">Figure 14</a>			200	ns
$t_{RHZ}$ , $t_{RLZ}$	Receiver output disable time				200	ns
$t_{DZH}$ , $t_{DZL}$	Driver output enable time	$R_L = 500\Omega$ , $C_L = 50pF$ , <a href="#">Figure 15</a>			200	ns
$t_{DZH}$ , $t_{DLZ}$	Driver output disable time				200	ns

## Pin Configuration, Top View

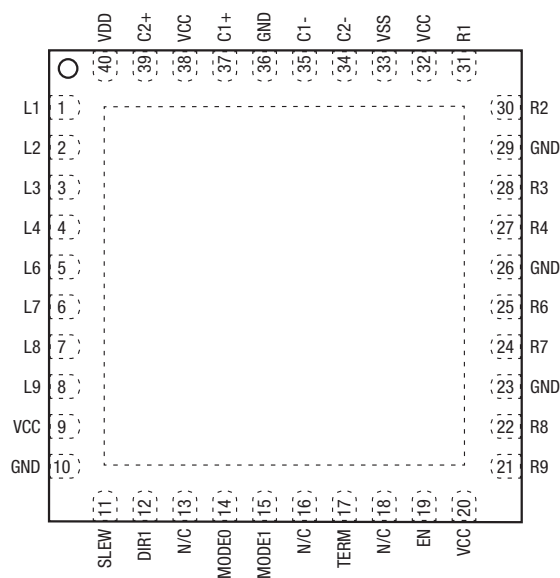

## Pin Functions

Pin Number	Pin Name	Descriptions by Mode (MODE1, MODE0)			
		Mode 00, Figure 2	Mode 01, Figure 3	Mode 10, Figure 4	Mode 11, Figure 5
1	L1	R1 output		1	1
2	L2	R2 output		R1 output	R1 output
3	L3	T1 input		T1 input	T1 input
4	L4	T2 input			
5	L6	R3 output		1	1
6	L7	T3 input			
7	L8	R4 output		1	1
8	L9	R5 output		1	1
9	VCC	V <sub>CC</sub>			
10	GND	Ground			
11	SLEW	SLEW = V <sub>CC</sub> enables 250kbps slew limiting			
12	DIR1			T1 enable, R1 disable	T1 enable
13	N/C	This pin is not used and is not connected internally			
14	MODE0	0	1	0	1
15	MODE1	0	0	1	1
16	N/C	This pin is not used and is not connected internally			
17	TERM			Enables RS-485/RS-422 receiver termination	
18	N/C	This pin is not used and is not connected internally			
19	EN	Enable = V <sub>CC</sub> for operation, Enable = 0V for shutdown			
20	VCC	V <sub>CC</sub>			

## Pin Functions (Continued)

Pin Number	Pin Name	Descriptions by Mode (MODE1, MODE0)			
		Mode 00, Figure 2	Mode 01, Figure 3	Mode 10, Figure 4	Mode 11, Figure 5
21	R9		R5 input		
22	R8		R4 input		
23	GND	Ground			
24	R7		T3 output		
25	R6		R3 input		
26	GND	Ground			
27	R4		T2 output		R1 input B
28	R3		T1 output		R2 input A
29	GND	Ground			
30	R2		R2 input	R1 input A, T1 output A	T1 output A
31	R1		R1 input	R1 input B, T1 output B	T1 output B
32	VCC	Supply voltage, 1.0 $\mu$ F to ground recommended for supply decoupling			
33	VSS	Charge pump negative supply (V-), 0.1 $\mu$ F from ground			
34	C2-	Charge pump cap 2 negative lead			
35	C1-	Charge pump cap 1 negative lead			
36	GND	Ground			
37	C1+	Charge pump cap 1 positive lead, 0.1 $\mu$ F			
38	VCC	V <sub>CC</sub>			
39	C2+	Charge pump cap 2 positive lead, 0.1 $\mu$ F			
40	VDD	Charge pump positive supply (V+), 0.1 $\mu$ F to ground			

## Suggested DB9 Connector Pinout

DB9 Pin	RS-232	RS-485/RS-422 Full Duplex	RS-485 Half Duplex
1	DCD	TX-	Data-
2	RXD	TX+	Data+
3	TXD	RX+	
4	DTR	RX-	
5	Ground		
6	DSR		
7	RTS		
8	CTS		
9	RI		



Functional Block Diagrams by Mode (MODE1, MODE0)

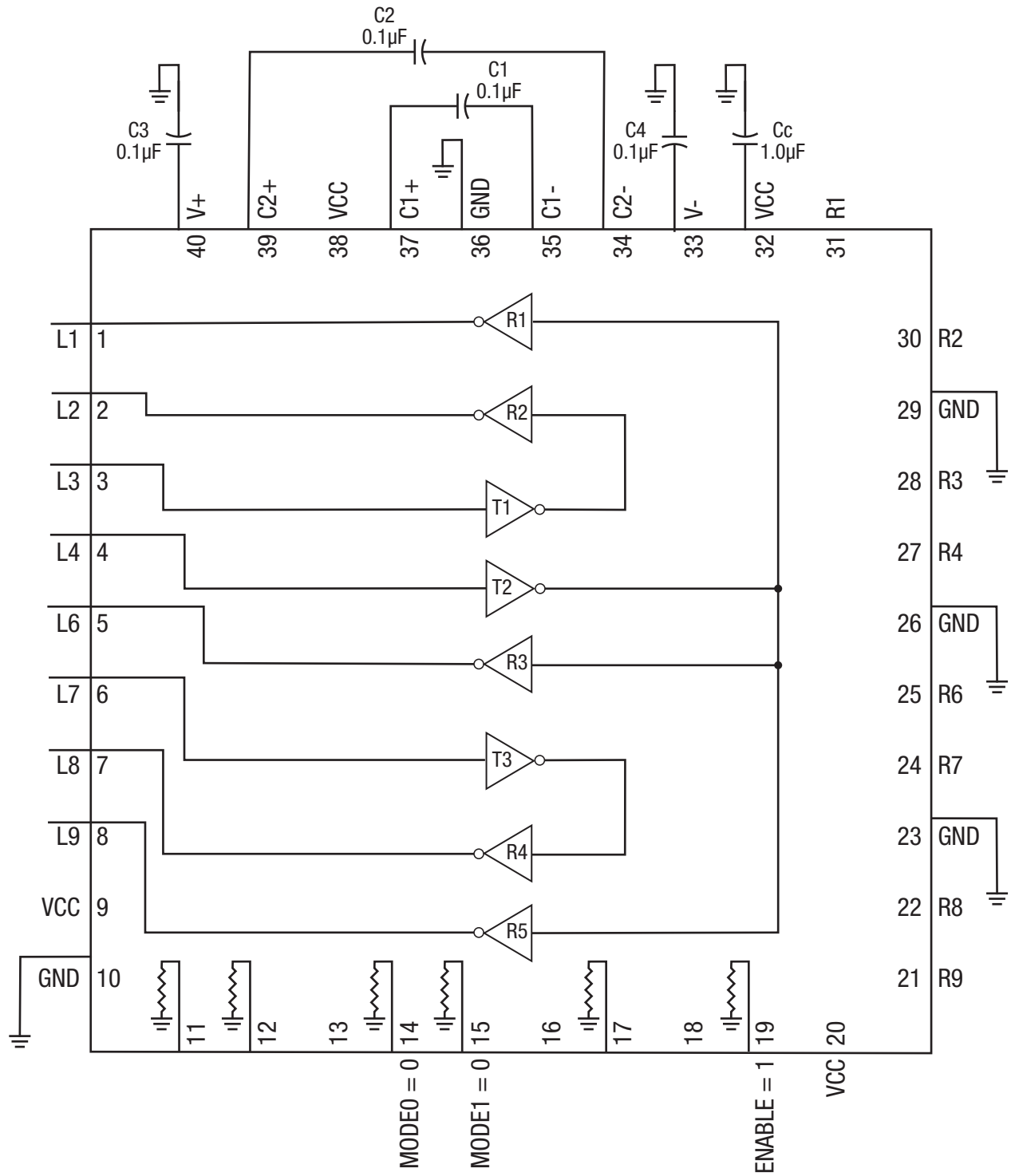

Figure 2: Functional Block Diagram - Mode 00, Loopback

Functional Block Diagrams by Mode (MODE1, MODE0) (Continued)

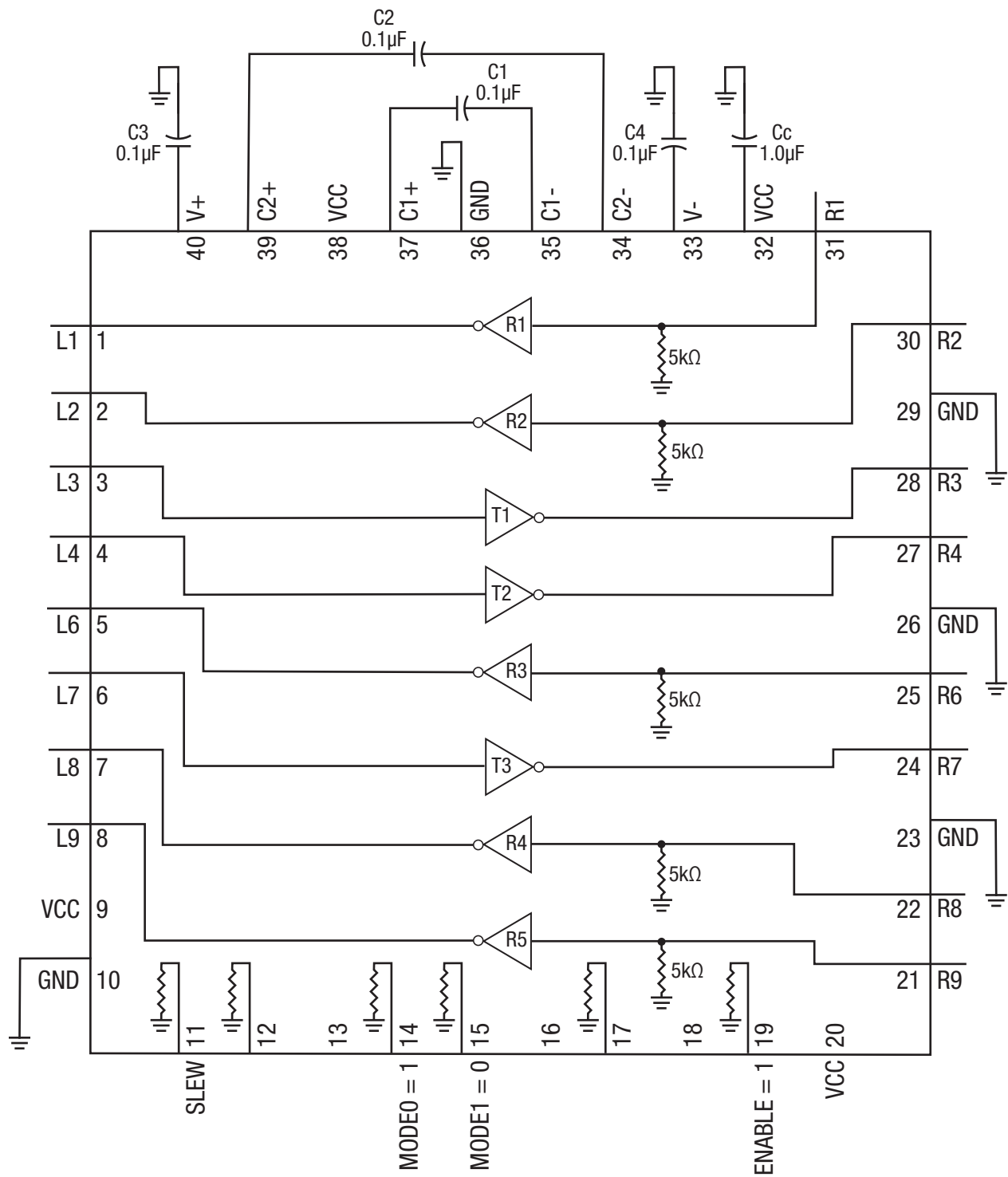

Figure 3: Functional Block Diagram - Mode 01, RS-232

Functional Block Diagrams by Mode (MODE1, MODE0) (Continued)

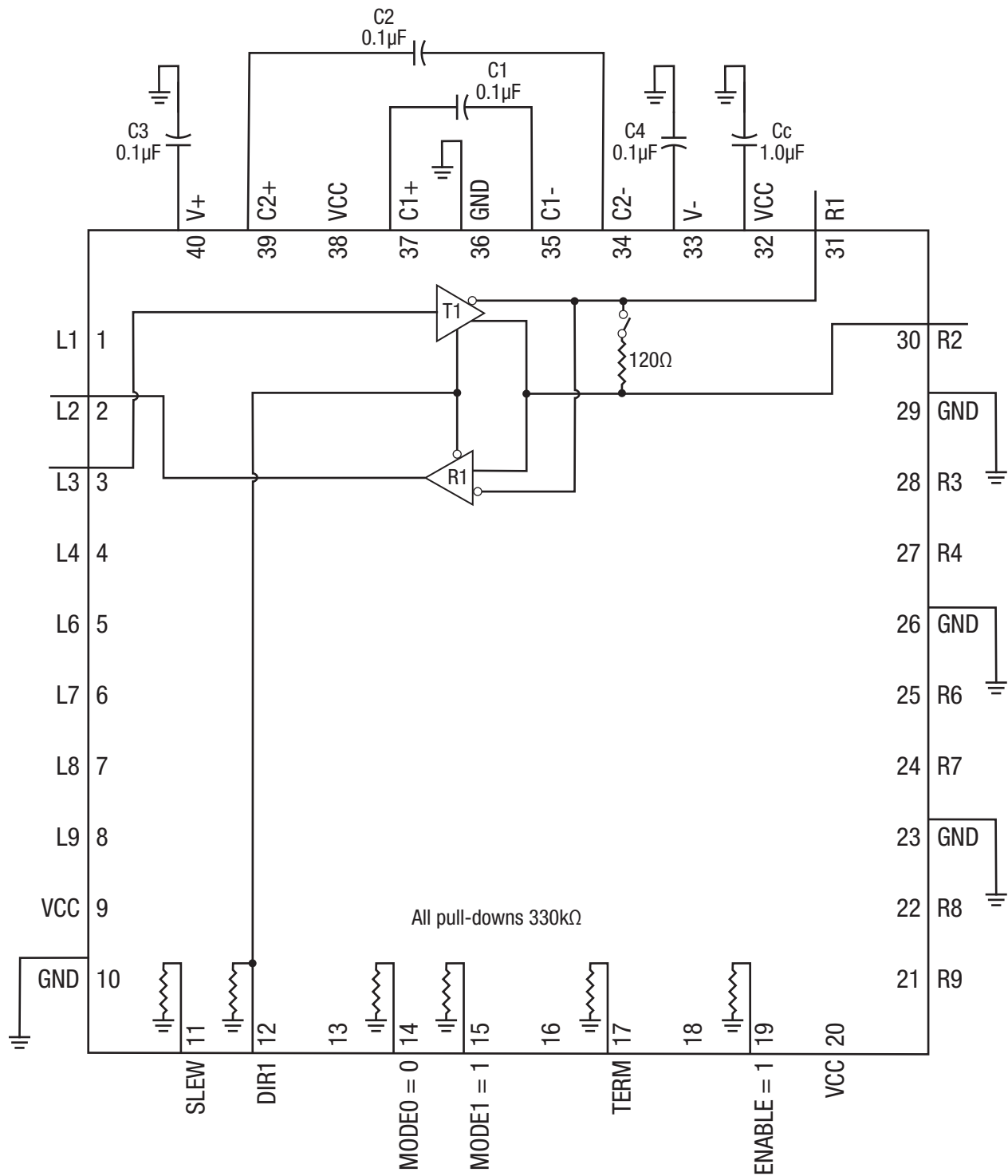

Figure 4: Functional Block Diagram - Mode 10, RS-485 Half Duplex

Functional Block Diagrams by Mode (MODE1, MODE0) (Continued)

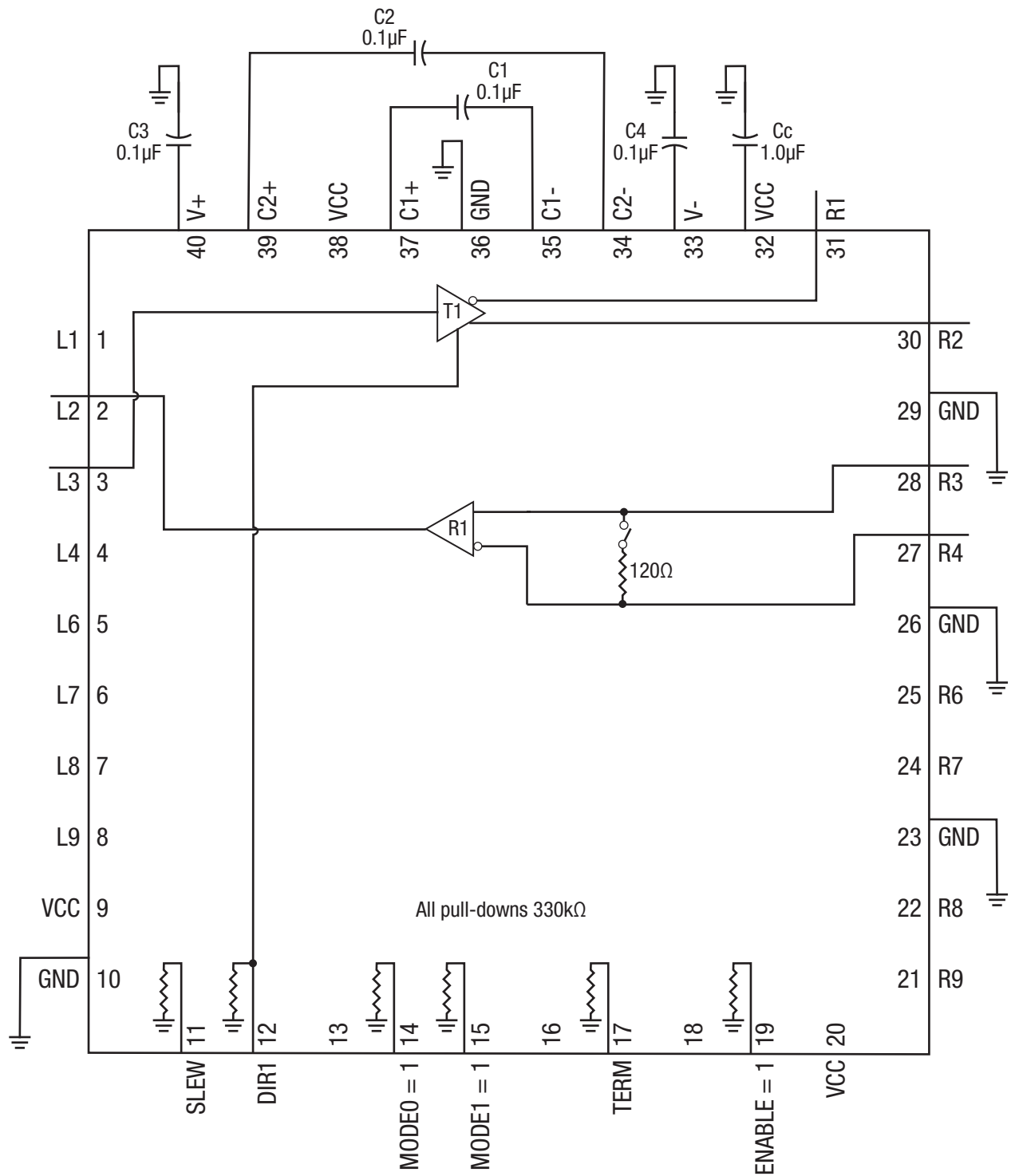
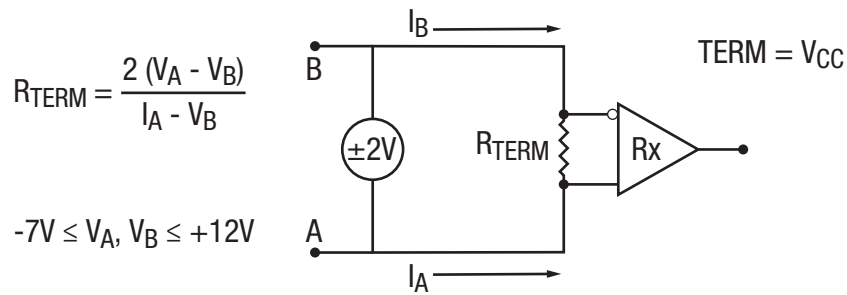

Figure 5: Functional Block Diagram - Mode 11, RS-485/RS-422 Full Duplex

Test Circuits



Termination is enabled in RS-485/RS-422 modes when the TERM pin is held high ( $V_{CC}$ ).

Figure 6: RS-485/RS-422 Receiver Termination Resistance

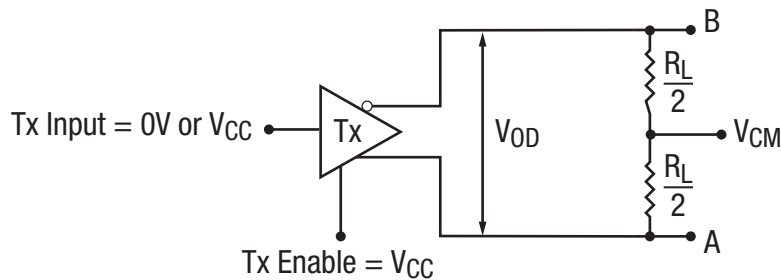

Figure 7: RS-485/RS-422 Differential Driver Output Voltage

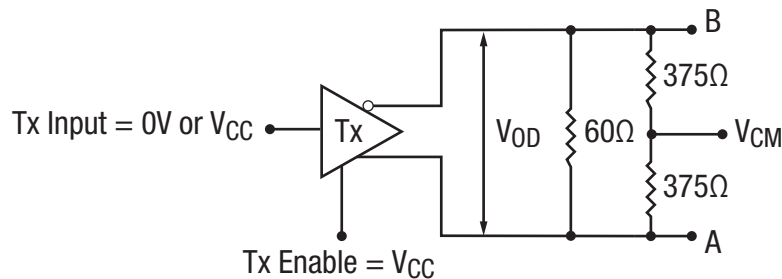

Figure 8: RS-485/RS-422 Differential Driver Output Voltage Over Common Mode

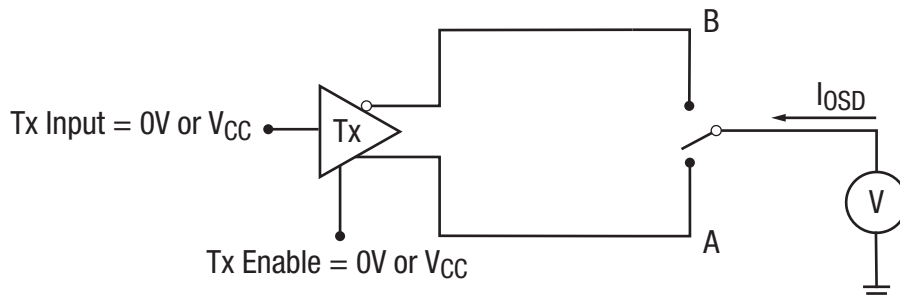

Figure 9: RS-485/RS-422 Driver Output Short-circuit Current

## Test Circuits (Continued)

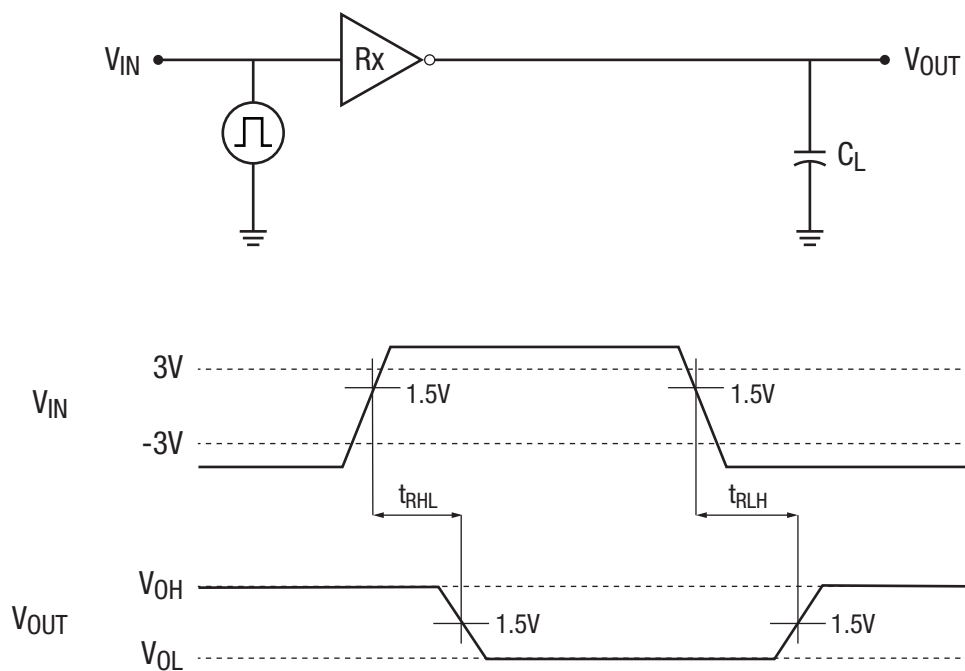

Figure 10: RS-232 Receiver Propagation Delay

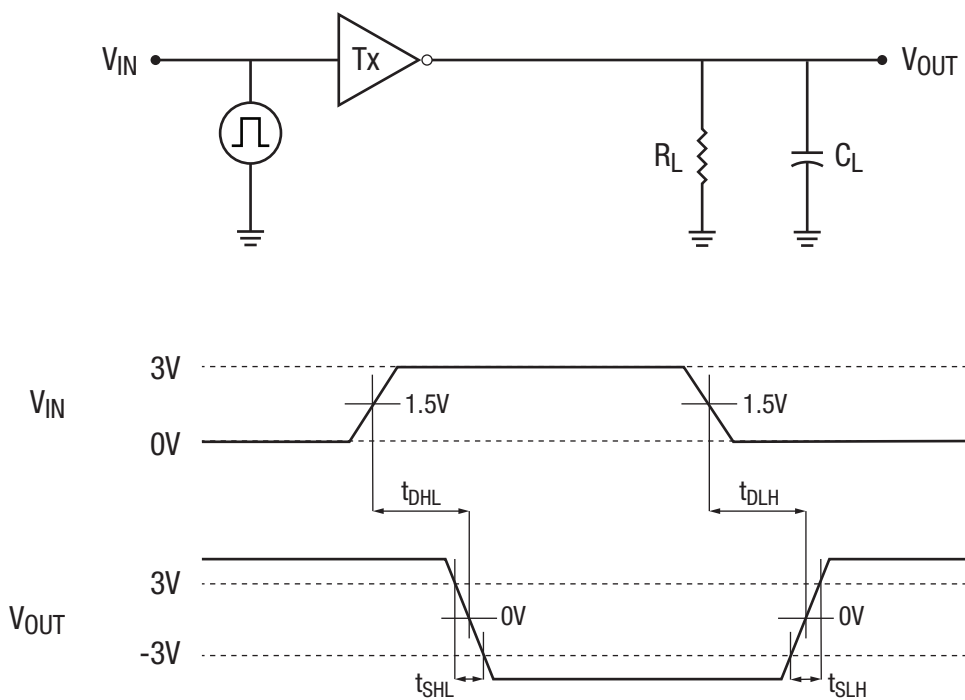

Figure 11: RS-232 Driver Propagation Delay

Test Circuits (Continued)

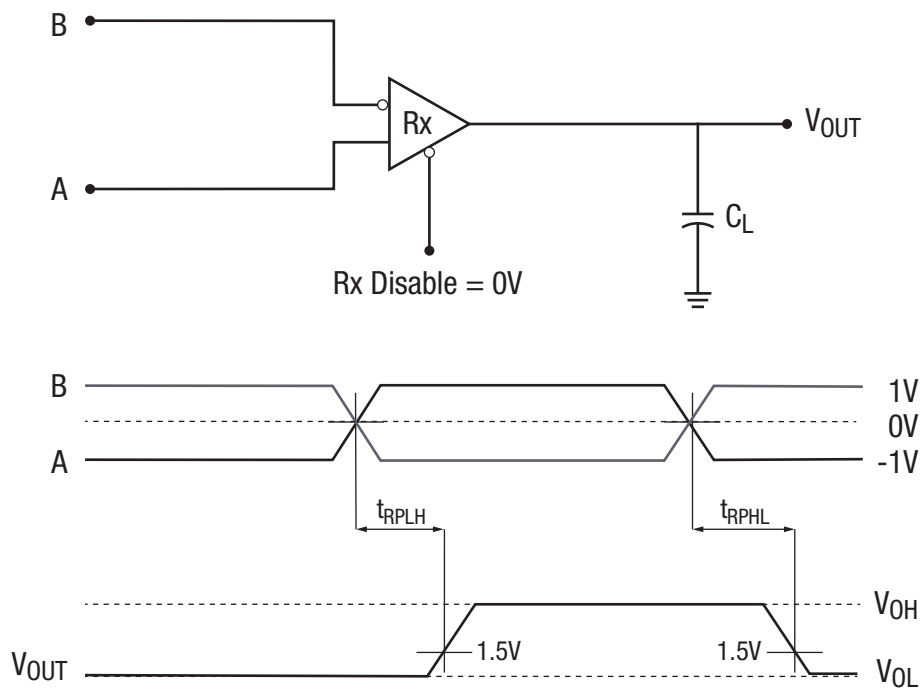

Figure 12: RS-485/RS-422 Receiver Propagation Delay

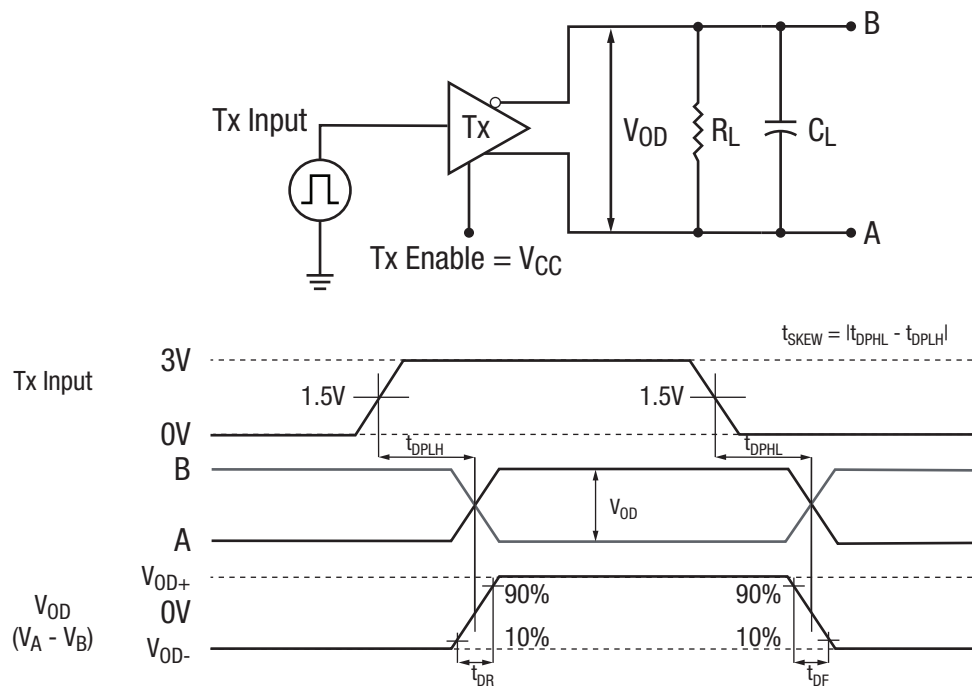

Figure 13: RS-485/RS-422 Driver Propagation Delay and Rise/Fall Times

## Test Circuits (Continued)

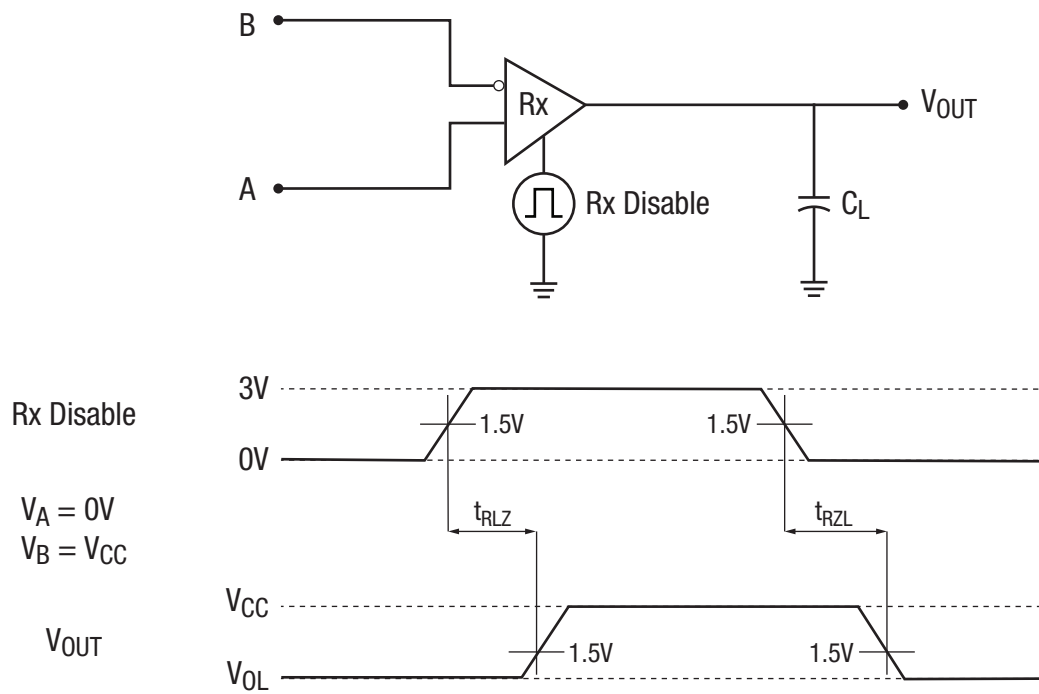

Figure 14: RS-485/RS-422 Receiver Output Enable/Disable Times



Test Circuits (Continued)

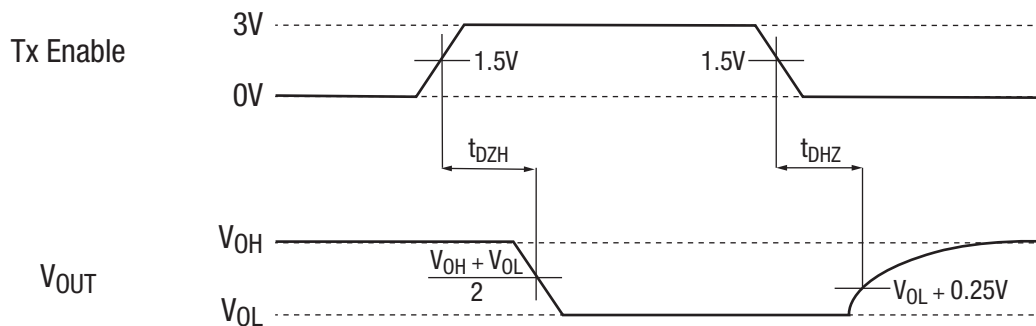
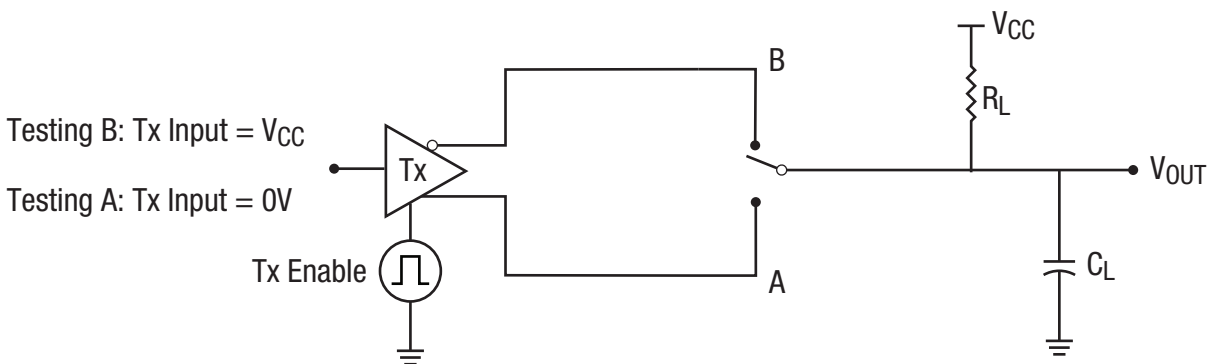
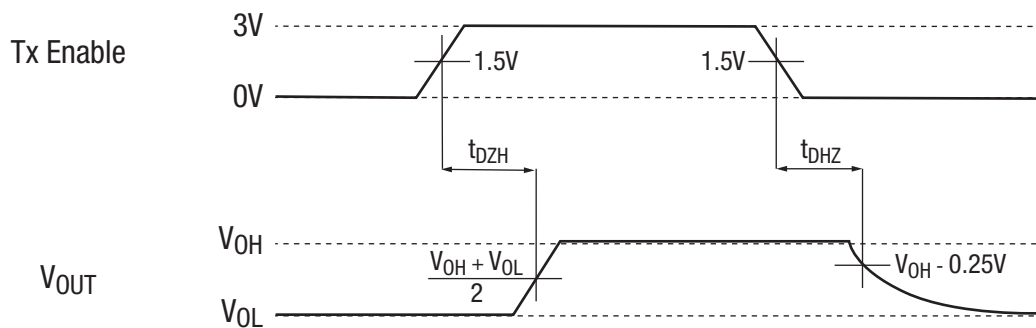
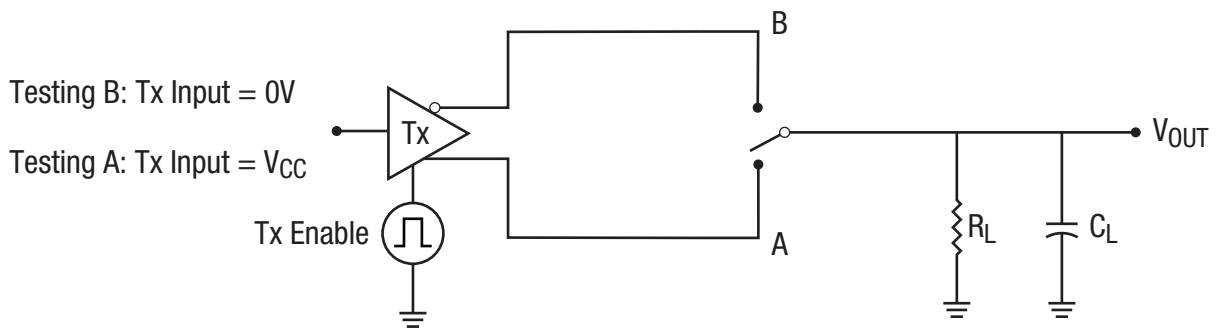

Figure 15: RS-485/RS-422 Driver Output Enable/Disable Times

## Applications Information

### Product Summary

The XR34350 is an advanced multiprotocol transceiver supporting RS-232, RS-485, and RS-422 serial standards in a 40-pin QFN package. Integrated cable termination and four configuration modes allow all three protocols to be used interchangeably over a single cable or connector with no additional switching components. The RS-485/RS-422 modes feature one driver and one receiver (1TX/1RX) in both half and full duplex configurations. The RS-232 mode (3TX/5RX) provides full support of all eight signals commonly used with the DB9 RS-232 connector. A dedicated mode is also available for diagnostic loopback testing.

### Internally Switched Cable Termination

Enabling and disabling the RS-485/RS-422 termination resistor is one of the largest challenges system designers face when sharing a single connector or pair of lines across multiple serial protocols. A termination resistor may be necessary for accurate RS-485/RS-422 communication, but must be removed when the lines are used for RS-232. XR34350 provides an elegant solution to this problem by integrating the termination resistor and switching control, and allowing it to be switched in and out of the circuit with a single pin. No external switching components are required.

### Enhanced Failsafe

Ordinary RS-485 differential receivers will be in an indeterminate state whenever the data bus is not being actively driven. The enhanced failsafe feature of the XR34350 guarantees a logic-high receiver output when the receiver inputs are open, shorted, or terminated but idle/undriven. The enhanced failsafe interprets 0V differential as a logic high with a minimum 50mV noise margin, while maintaining compliance with the EIA/TIA-485 standard of  $\pm 200\text{mV}$ . No external biasing resistors are required, further easing the usage of multiple protocols over a single connector.

### $\pm 15\text{kV}$ ESD Protection

ESD protection structures are incorporated on all pins to protect against electrostatic discharges encountered during handling and assembly. The bus pins (driver outputs and receiver inputs) have extra protection structures, which have been tested up to  $\pm 15\text{kV}$  without damage. These structures withstand high ESD in all states: normal operation, shutdown and powered down.

ESD protection is tested in various ways. MaxLinear uses the following methods to qualify the protection structures designed into XR34350:

- $\pm 15\text{kV}$  using the Human Body Model (HBM)
- $\pm 8\text{kV}$  using IEC 61000-4-2 Contact Discharge
- $\pm 15\text{kV}$  using IEC 61000-4-2 Air Gap Discharge

The IEC 61000-4-2 standard is more rigorous than HBM, resulting in lower voltage levels compared with HBM for the same level of ESD protection. Because IEC 61000-4-2 specifies a lower series resistance, the peak current is higher than HBM. The XR34350 has passed both HBM and IEC 61000-4-2 testing without damage.

### Diagnostic Loopback Mode

The XR34350 includes a diagnostic digital loop back mode for system testing as shown in [Figure 2](#). The loopback mode connects the TTL driver inputs to the TTL receiver outputs, bypassing the analog driver and receiver circuitry. The analog/bus pins are internally disconnected in this mode.

Mechanical Dimensions

QFN-40

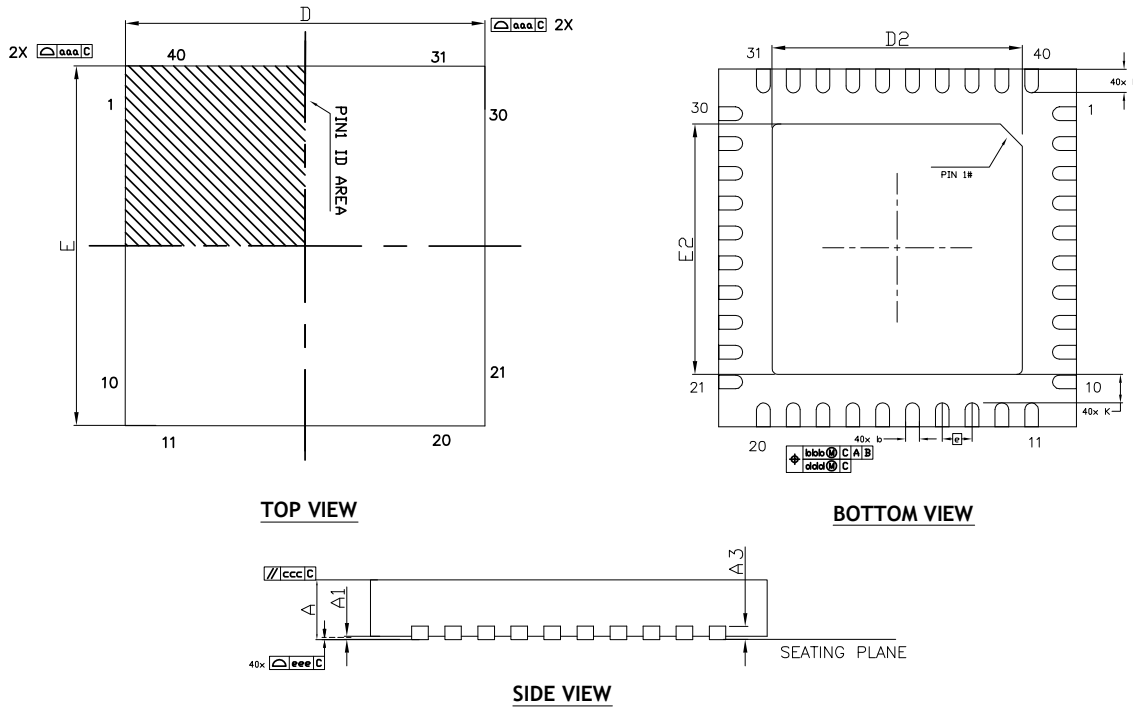

DIMENSION TABLE				
SYMBOL	MIN	NOM	MAX	NOTE
A	0.80	0.90	1.00	
A1	0.00	0.02	0.05	
A3	---	0.20Ref	---	
b	0.20	0.25	0.30	
D	6.00 BSC			
E	6.00 BSC			
e	0.50 BSC			
D2	4.50	4.65	4.80	
E2	4.50	4.65	4.80	
L	0.35	0.40	0.45	
K	0.20	-	-	
aaa		0.15		
bbb		0.10		
ccc		0.10		
ddd		0.05		
eee		0.08		
N		40		

TERMINAL DETAILS

- ALL DIMENSIONS ARE IN MILLIMETERS, ANGLES ARE IN DEGREES.
- DIMENSIONS AND TOLERANCE PER JEDEC MO-220.

Drawing No.: POD-0000041

Revision: B.2

## Recommended Land Pattern and Stencil

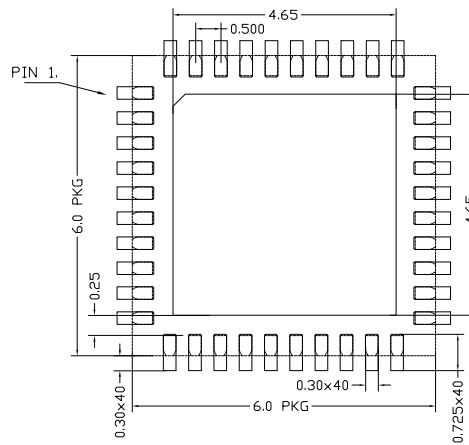

**TYPICAL RECOMMENDED LAND PATTERN**

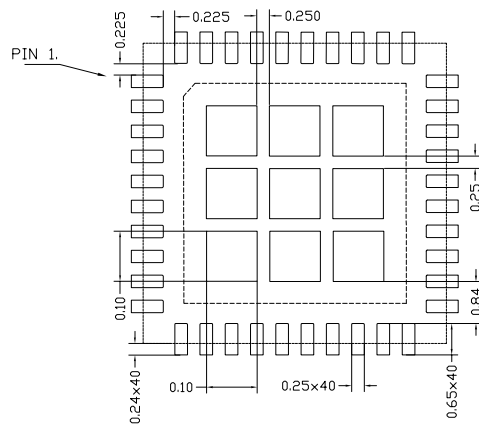

**TYPICAL RECOMMENDED STENCIL**

Drawing No.: POD-0000041

Revision: B.2

## Tape Orientation

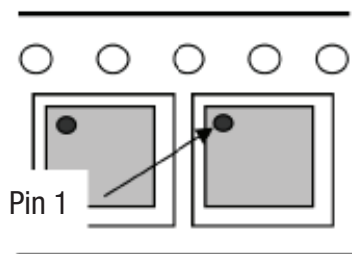

**Pin 1 Orientation in Tape**

Order Information<sup>(1)</sup>

Part Number	Operating Temperature Range	Lead-Free	Package	Packaging Method
XR34350IL	-40°C to 85°C	Yes <sup>(2)</sup>	40-pin QFN	Tray
XR34350ILTR				Tape and Reel
XR34350ILEVB	XR34350 Evaluation Board			

**NOTE:**

1. Refer to [www.exar.com/XR34350](http://www.exar.com/XR34350) for most up-to-date Ordering Information.
2. Visit [www.exar.com](http://www.exar.com) for additional information on Environmental Rating.

## Revision History

Revision	Date	Description
1A	March 2016	Initial Release
1B	June 2016	Updated datasheet format
1C	March 2018	Corrected 120Ω resistor values in Figures 4 and 5; corrected Figure 5 T1 trace. Updated to MaxLinear logo. Updated format and ordering information, added EVB.



**Corporate Headquarters:**  
 5966 La Place Court  
 Suite 100  
 Carlsbad, CA 92008  
 Tel.: +1 (760) 692-0711  
 Fax: +1 (760) 444-8598  
[www.maxlinear.com](http://www.maxlinear.com)

**High Performance Analog:**  
 1060 Rincon Circle  
 San Jose, CA 95131  
 Tel.: +1 (669) 265-6100  
 Fax: +1 (669) 265-6101  
 Email: [serialtechsupport@exar.com](mailto:serialtechsupport@exar.com)  
[www.exar.com](http://www.exar.com)

The content of this document is furnished for informational use only, is subject to change without notice, and should not be construed as a commitment by MaxLinear, Inc.. MaxLinear, Inc. assumes no responsibility or liability for any errors or inaccuracies that may appear in the informational content contained in this guide. Complying with all applicable copyright laws is the responsibility of the user. Without limiting the rights under copyright, no part of this document may be reproduced into, stored in, or introduced into a retrieval system, or transmitted in any form or by any means (electronic, mechanical, photocopying, recording, or otherwise), or for any purpose, without the express written permission of MaxLinear, Inc.

MaxLinear, Inc. does not recommend the use of any of its products in life support applications where the failure or malfunction of the product can reasonably be expected to cause failure of the life support system or to significantly affect its safety or effectiveness. Products are not authorized for use in such applications unless MaxLinear, Inc. receives, in writing, assurances to its satisfaction that: (a) the risk of injury or damage has been minimized; (b) the user assumes all such risks; (c) potential liability of MaxLinear, Inc. is adequately protected under the circumstances.

MaxLinear, Inc. may have patents, patent applications, trademarks, copyrights, or other intellectual property rights covering subject matter in this document. Except as expressly provided in any written license agreement from MaxLinear, Inc., the furnishing of this document does not give you any license to these patents, trademarks, copyrights, or other intellectual property.

Company and product names may be registered trademarks or trademarks of the respective owners with which they are associated.

Компания «Океан Электроники» предлагает заключение долгосрочных отношений при поставках импортных электронных компонентов на взаимовыгодных условиях!

Наши преимущества:

- Поставка оригинальных импортных электронных компонентов напрямую с производств Америки, Европы и Азии, а так же с крупнейших складов мира;
- Широкая линейка поставок активных и пассивных импортных электронных компонентов (более 30 млн. наименований);
- Поставка сложных, дефицитных, либо снятых с производства позиций;
- Оперативные сроки поставки под заказ (от 5 рабочих дней);
- Экспресс доставка в любую точку России;
- Помощь Конструкторского Отдела и консультации квалифицированных инженеров;
- Техническая поддержка проекта, помощь в подборе аналогов, поставка прототипов;
- Поставка электронных компонентов под контролем ВП;
- Система менеджмента качества сертифицирована по Международному стандарту ISO 9001;
- При необходимости вся продукция военного и аэрокосмического назначения проходит испытания и сертификацию в лаборатории (по согласованию с заказчиком);
- Поставка специализированных компонентов военного и аэрокосмического уровня качества (Xilinx, Altera, Analog Devices, Intersil, Interpoint, Microsemi, Actel, Aeroflex, Peregrine, VPT, Syfer, Eurofarad, Texas Instruments, MS Kennedy, Miteq, Cobham, E2V, MA-COM, Hittite, Mini-Circuits, General Dynamics и др.);

Компания «Океан Электроники» является официальным дистрибьютором и эксклюзивным представителем в России одного из крупнейших производителей разъемов военного и аэрокосмического назначения «JONHON», а так же официальным дистрибьютором и эксклюзивным представителем в России производителя высокотехнологичных и надежных решений для передачи СВЧ сигналов «FORSTAR».



## JONHON

«JONHON» (основан в 1970 г.)

Разъемы специального, военного и аэрокосмического назначения:

(Применяются в военной, авиационной, аэрокосмической, морской, железнодорожной, горно- и нефтедобывающей отраслях промышленности)

«FORSTAR» (основан в 1998 г.)

ВЧ соединители, коаксиальные кабели, кабельные сборки и микроволновые компоненты:

(Применяются в телекоммуникациях гражданского и специального назначения, в средствах связи, РЛС, а так же военной, авиационной и аэрокосмической отраслях промышленности).



Телефон: 8 (812) 309-75-97 (многоканальный)

Факс: 8 (812) 320-03-32

Электронная почта: [ocean@oceanchips.ru](mailto:ocean@oceanchips.ru)

Web: <http://oceanchips.ru/>

Адрес: 198099, г. Санкт-Петербург, ул. Калинина, д. 2, корп. 4, лит. А