

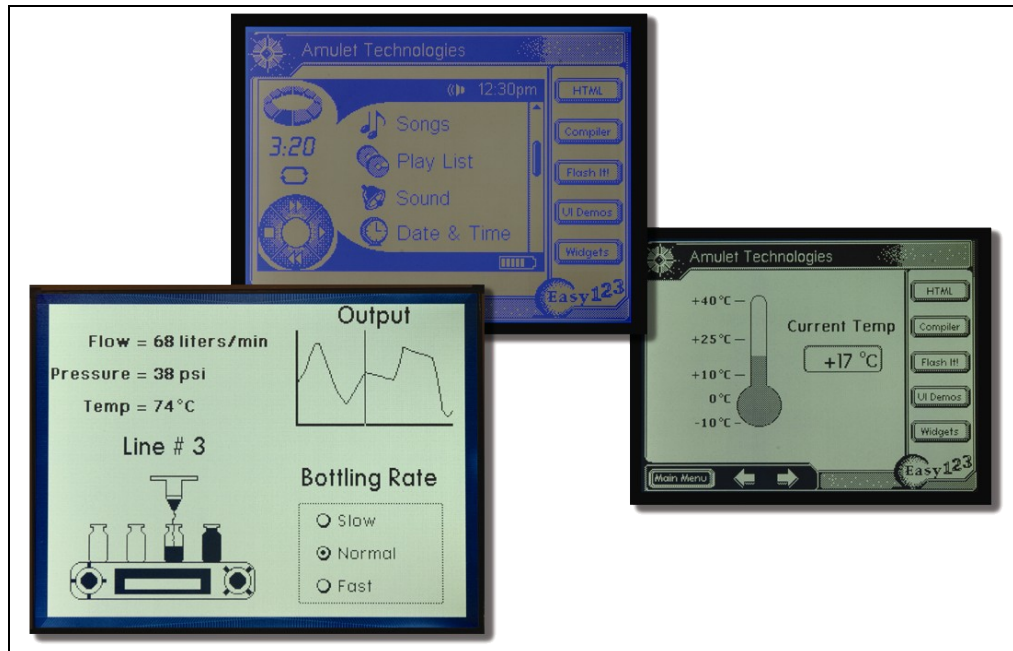

275 Saratoga Ave., Suite 230
Santa Clara, CA 95050

Web: <http://www.amulettechnologies.com>
Phone: (408) 244-0363
Fax (408) 243-5457

Specification: Amulet On-Board 5.7" Module (RoHS)



**Part Number: MK-AOB3202405B
MK-AOB3202405N
MK-AOB3202405T**

Contents

1. Amulet On-Board Module Information
2. Precautions in Use of Amulet On-Board Module
3. General Specification
4. Absolute Maximum Ratings & Electrical Characteristics
5. Optical Characteristics
6. Interface Description
7. Contour Drawing
8. Quality Assurance
9. Reliability
10. Backlight Information
11. Touch Panel Information
12. RoHS Certificate of Compliance

1. Amulet On-Board Module Information

MK-AOB 320240 5 B

1 2 3 4

1 Product Type: Amulet On-Board Module
2 Display Resolution: 320 x 240 Pixels
3 Display Type: 5.7" Graphic LCD
4 Display Modes: **B**= STN Negative, Blue, Transmissive
 N= FSTN Negative, Transmissive
 I= FSTN Positive, Transflective

Backlight Type: Ultrabright White LED (8)
Backlight Control: Digital Potentiometer
Contrast Control: Digital Potentiometer
Viewing Angle: 6 o'clock
Operating Temp: -20°C to 70°C
Temperature Comp: Yes
Power Requirement: 5Vdc (±.25v) @ 250mA

Memory

µHTML Storage Capacity: 8 megabit

Communication Interface

Communication Type: Amulet Protocol via UART
Data Rate (BAUD): 9,600 / 19,200 / 57,600 / 115,200 bps

2. Precautions in Use of Amulet On-Board Module

- Avoid applying excessive shocks to the module or making any alterations or modifications to it.
- Do not make extra holes on the printed circuit board, modify its shape or change any components.
- Do not disassemble the module.
- Do not operate it above the absolute maximum ratings.
- Do not drop, bend or twist module.
- Storage: Store in anti-static electricity container and in a clean environment.

3. General Specification

ITEM	STANDARD VALUE	UNIT
Number of Pixels	320 x 240	dots
Outline Dimension	160.0(W) x 109.0(H) x 11.4max(T)	mm
View Area	122.0(W) x 92.0(H)	mm
Active Area	119.2(W) x 90.3(H)	mm
Dot Size	0.34(W) x 0.34(H)	mm
Dot Pitch	0.36(W) x 0.36(H)	mm
LCD Type	B = STN Negative, Blue, Transmissive N = FSTN Negative, Transmissive T = FSTN Positive, Transflective	
View Direction	6 o'clock	
Backlight	Ultrabright White LED (8)	

4. Absolute Maximum Ratings & Electrical Characteristics

ITEM	SYMBOL	MIN.	TYP.	MAX.	UNIT
Operating Temperature	T _{OP}	-20	-	+70	°C
Storage Temperature	T _{ST}	-30	-	+80	°C
Logic Voltage	V _{DD}	3.0	3.3	3.60	V
Supply Voltage For Module	V _{CC}	4.75	5.00	5.25	V
CMOS Input	(VDD tolerant only)				
Input High Voltage	V _{IH}	2.0	-	-	V
Input Low Voltage	V _{IL}	-	-	0.8	V
Input Leakage Current	I _L	-	-	5	μA
CMOS Output	(VDD tolerant only)				
Output High Voltage	V _{OH}	2.8	-	-	V
Output Low Voltage	V _{OL}	-	-	0.2	V
Pull-up Resistor	R _I	37K	-	202K	Ω
Supply Current		240	250	270	mA

5. Optical Characteristics

ITEM	SYMBOL	CONDITION	MIN	TYP	MAX	UNIT
View Angle MK-AOB3202405B	(V) θ	$CR \geq 2$	20	-	40	deg.
	(H) ϕ	$CR \geq 2$	-30	-	30	deg.
View Angle MK-AOB3202405N	(V) θ	$CR \geq 2$	30	-	60	deg.
	(H) ϕ	$CR \geq 2$	-45	-	45	deg.
View Angle MK-AOB3202405T	(V) θ	$CR \geq 2$	30	-	60	deg.
	(H) ϕ	$CR \geq 2$	-45	-	45	deg.
Contrast Ratio	CR	-	-	5	-	-
Response Time	T rise	-	-	200	300	ms
	T fall	-	-	150	200	ms

5.1 Definitions

■View Angles

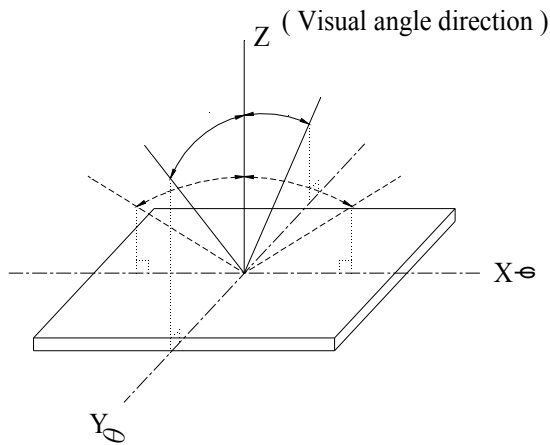

■Contrast Ratio

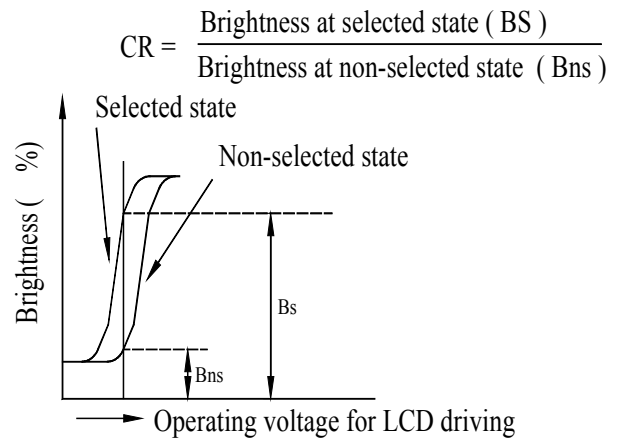

■Response time

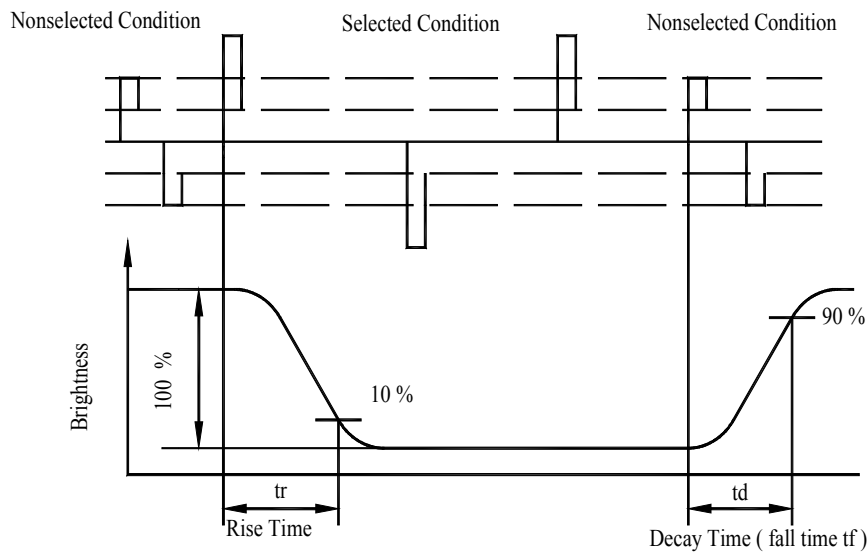

6. Interface Description

Pin Type

I = ¹CMOS Input
 O = ¹CMOS Output
 P = Power Supply

¹The I/O pins are only VDD tolerant and must adhere to the voltage levels depicted in Section 4 (Absolute Maximum Ratings & Electrical Characteristics).

Pin #	Signal	Type	Description
1	GND	P	Ground.
2	GND	P	Ground.
3	/FSS	O	¹ Flash slave select. This pin should be left unconnected.
4	TXD	O	¹ Asynchronous data output.
5	/TSS	O	¹ Touch panel slave select. This pin should be left unconnected.
6	RXD	I	^{1,6} Asynchronous data input.
7	/CSS	O	¹ Contrast slave select. This pin should be left unconnected.
8	GND	P	Ground.
9	/BSS	O	¹ Backlight slave select. This pin should be left unconnected.
10	PROG MODE	I	^{1,2,6} System power up mode. A low level boots Amulet in run mode. A high level boots Amulet in program mode.
11	/SS4	O	¹ SPI slave select 4. This pin is for future use and should be left unconnected.
12	TPC	I	^{1,4,6} Touch panel calibration mode. A low level does not perform a calibration session. A high level performs a calibration session.
13	/SS5	O	¹ SPI slave select 5. This pin is for future use and should be left unconnected.
14	FFBS	I	^{1,3,6} Flash programming baud rate. A low level sets the flash programming rate to 19,200 bps. A high level sets the flash programming rate to 115,200 bps.
15	/SS6	O	¹ SPI slave select 6. This pin is for future use and should be left unconnected.
16	GND	P	Ground.
17	RAMTSTO	O	¹ External SRAM test results. This pin should be left unconnected.
18	/RESET	I	^{1,6,7} System reset. A low level of 10us or longer will generate a system reset.
19	GND	P	Ground.
20	/IRQ	I	^{1,6} System interrupt. This pin should be left unconnected.
21	SCLK	O	¹ SPI clock. This pin should be left unconnected.
22	GND	P	Ground.
23	MISO	I	^{1,6} SPI data in. This pin should be left unconnected.
24	GND	P	Ground.
25	MOSI	O	¹ SPI data out. This pin should be left unconnected.
26	GND	P	Ground.
27	GND	P	Ground.
28	V _{CC}	P	⁵ Supply voltage for module. A regulated voltage between 4.75V and 5.25V should be applied to this pin.
29	GND	P	Ground.
30	V _{CC}	P	⁵ Supply voltage for module. A regulated voltage between 4.75V and 5.25V

should be applied to this pin.

- ¹ The I/O pins are only VDD tolerant and must adhere to the voltage levels depicted in Section 4 (Absolute Maximum Ratings & Electrical Characteristics).
- ² Input pin is read upon power up, a system reset, or when writing to flash.
- ³ Input pin is only read when a flash programming session has been initiated.
- ⁴ Input pin is read upon power up or a system reset.
- ⁵ Supply voltage must provide 5V @ 250mA.
- ⁶ Internally pulled high. If pin is externally connected, interface it to an open collector output.

6.1 Typical Interface

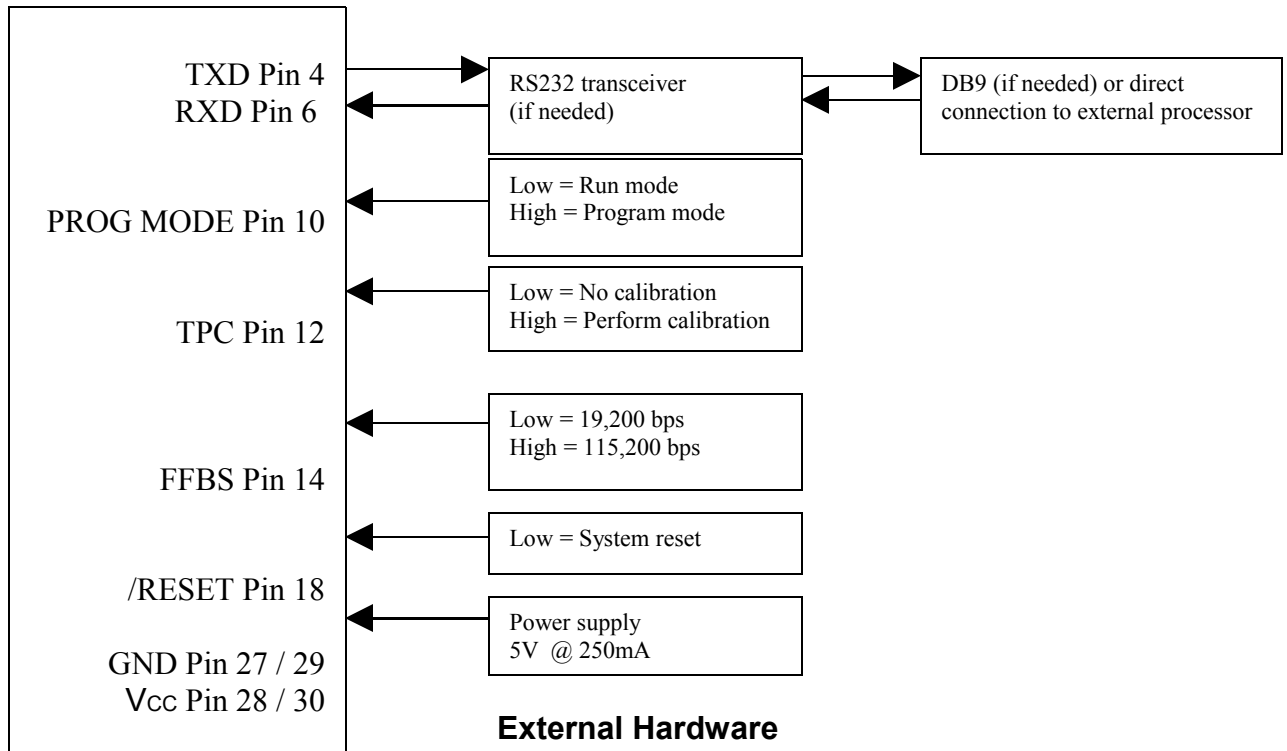

7. Contour Drawing

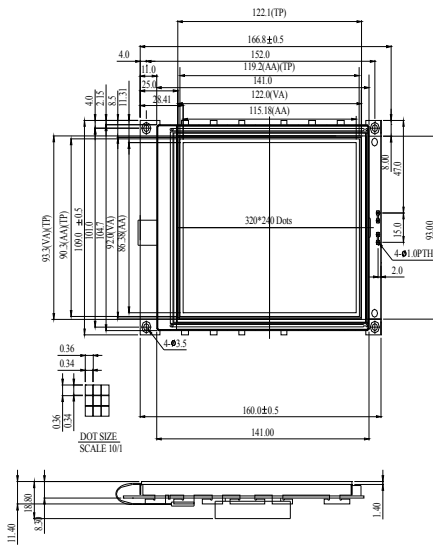

PIN NO.	SYMBOL	PIN NO.	SYMBOL
1	GND	2	GND
3	SS0	4	TXD
5	SS1	6	RXD
7	SS2	8	GND
9	SS3	10	Boot M
11	SS4	12	ICAL
13	SS5	14	BAVD
15	SS6	16	GND
17	SS7	18	RESET
19	GND	20	IRQ
21	SCLK	22	GND
23	MISO	24	GND
25	MISO	26	GND
27	GND	28	VCC
29	GND	30	VCC

Pin No.	Symbol	Pin No.	Symbol
1	GND	2	GND
3	/FSS	4	TXD
5	/TSS	6	RXD
7	/CSS	8	GND
9	/BSS	10	PROG MODE
11	/SS4	12	TPC
13	/SS5	14	FFBS
15	/SS6	16	GND
17	RAMTSTO	18	/RESET
19	GND	20	/IRQ
21	SCLK	22	GND
23	MISO	24	GND
25	MOSI	26	GND
27	GND	28	VCC
29	GND	30	VCC

LCD INTERFACE HEADER J1
(30 PIN CONNECTOR)

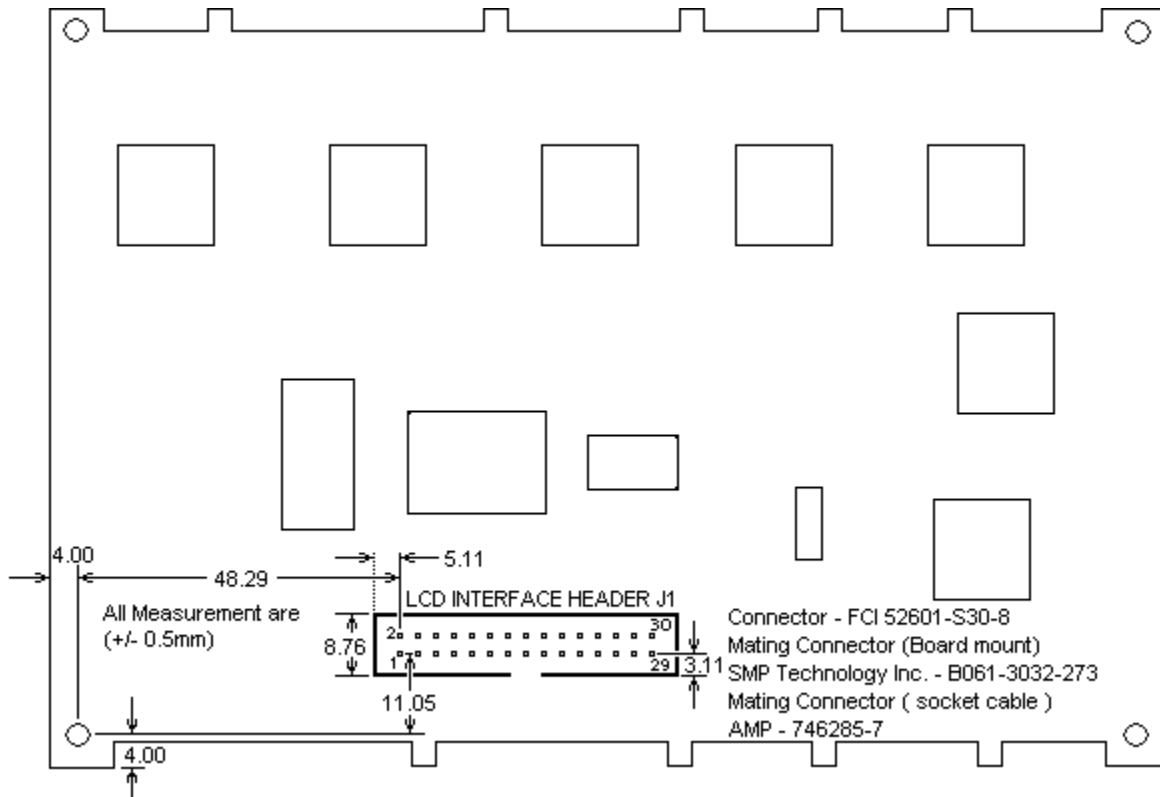

8. Quality Assurance

Screen Cosmetic Criteria

NO.	DEFECT	JUDGMENT CRITERION	PARTITION
1	Spots	<p>A) Clear</p> <p>Size: d mm Acceptable Qty in active area</p> <p>d≤0.1 Disregard</p> <p>0.1<d≤0.2 6</p> <p>0.2<d≤0.3 2</p> <p>0.3<d 0</p> <p>Note: Including pinholes and defective dots, which must be within one pixel size.</p> <p>B) Unclear</p> <p>Size: d mm Acceptable Qty in active area</p> <p>d≤0.2 Disregard</p> <p>0.2<d≤0.5 6</p> <p>0.5<d≤0.7 2</p> <p>0.7<d 0</p>	Minor
2	Bubbles in polarizer	<p>Size: d mm Acceptable Qty in active area</p> <p>d≤0.3 Disregard</p> <p>0.3<d≤1.0 3</p> <p>1.0<d≤1.5 1</p> <p>1.5<d 0</p>	Minor
3	Scratch	In accordance with spots cosmetic criteria. When the light reflects on the panel surface, the scratches are not to be remarkable.	Minor
4	Allowable density	Above defects should be separated by more than 30mm from each other.	Minor
5	Coloration	Not to be noticeable in the viewing area of the LCD panels. Backlight type should be judged with the backlight in the on state only.	Minor

9. Reliability

Content of Reliability Test

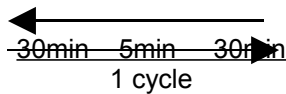
Environmental Test				
NO.	TEST ITEM	CONTENT OF TEST	TEST CONDITION	APPLICABLE STANDARD
1	High temperature storage	Endurance test applying the high storage temperature for a long time.	80°C 200hrs	—
2	Low temperature storage	Endurance test applying the low storage temperature for a long time.	-30°C 200hrs	—
3	High temperature operation	Endurance test applying the electric stress (Voltage & Current) and the thermal stress to the element for a long time.	70°C 200hrs	—
4	Low temperature operation	Endurance test applying the electric stress under low temperature for a long time.	-20°C 200hrs	—
5	High temperature/humidity storage	Endurance test applying the high temperature and high humidity storage for a long time.	80°C,90%RH 96hrs	—
6	High temperature/humidity operation	Endurance test applying the electric stress (Voltage & Current) and temperature / humidity stress to the element for a long time.	70°C,90%RH 96hrs	—
7	Temperature cycle	Endurance test applying the low and high temperature cycle. 	-30°C /80°C 10 cycles	—
Mechanical Test				
8	Vibration test	Endurance test applying the vibration during transportation and use.	10~22Hz→1.5mmp-p 22~500Hz→1.5G Total 0.5hrs	—
9	Shock test	Constructional and mechanical endurance test applying the shock during transportation.	50G Half sign wave 11 msdc 3 times of each direction	—
10	Atmospheric pressure test	Endurance test applying the atmospheric pressure during air transportation.	115mbar 40hrs	—
Others				
11	Static electricity test	Endurance test applying the electrical stress to the terminal.	VS=800V,RS=1.5kΩ CS=100pF 1 time	—

10. Backlight Information

(Ta=25°C)

PARAMETER	SYMBOL	MIN.	TYP.	MAX.	UNIT	TEST CONDITION
Luminous intensity	IV	--	380	--	CD/M ²	ILED=128mA
Life time	--	--	50K	--	Hr.	V _≤ 5Vdc
Color					White	

11. Touch Panel Information

- NOTES:
1. NO GLASS THICKNESS : 1.1mm
 2. NO PET TOP CIRCUIT THICKNESS : 0.2mm
 3. SPACER ADHESIVE : 0.1mm
 4. DIABALL THICKNESS : 1.40mm ±0.07
 5. CONNECTOR AND PINOUT AS INDICATED
 6. FRONT SURFACE ANGLE AS INDICATED
 7. OPTICAL SPECIFICATION : ABOUT
 8. LAYER TO LAYER ASSEMBLY TOLERANCE : ±0.3mm

Pos #	Assignment
1	Right
2	Left
3	Bottom
4	Top

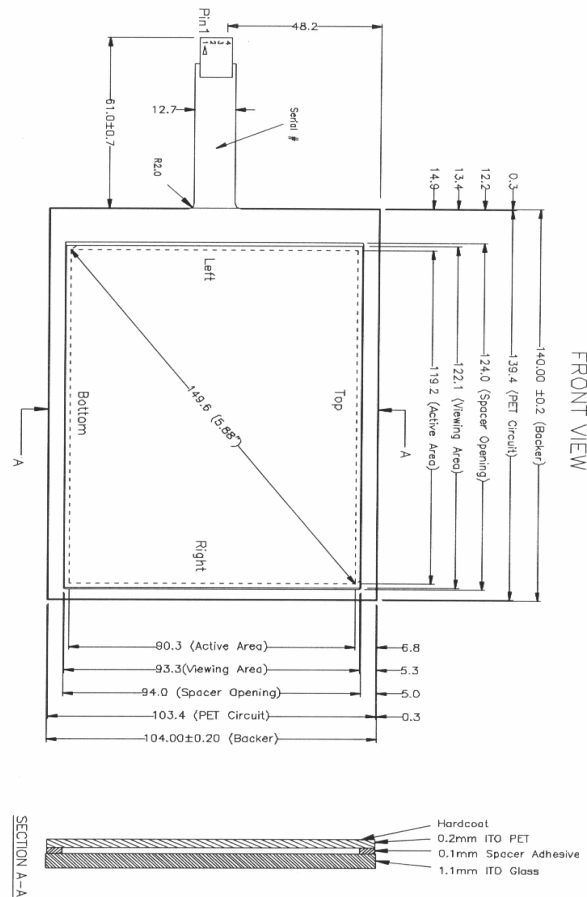

11.1 Machine Specifications

ITEM	SPECIFICATION	CONDITION
Operating force	Less than 80g	R8.0 HS 40 ° Silicon rubber or R0.8 Polyacetal pen
Surface hardness	More than 2H	Pencil test
Light transmission	More than 80%	@550nm Hitachi U3300
Durability for pen selections	More than 1,200,000 times	Force:250g Speed:2cm/sec

12. RoHS Certificate of Compliance



Certificate of Compliance

February 6, 2007

Amulet Technologies hereby certifies that the Amulet OnBoard (AOB) Modules are compliant with the EU Directive 2002/95/EC and for the Restriction of the use of certain Hazardous Substances in Electrical and Electronic Equipment (RoHS).

No Lead (Pb), Mercury (Hg), Cadmium (Cd), Hexavalent Chromium Cr+6), Polybrominated Biphenyl (PBB), or Polybrominated Diphenyl Ether (PBDE) is intentionally added to the part. Any trace impurities of the RoHS substances in the parts are below the RoHS specified levels.

	Toxic or Hazardous Substances and Elements					
	Lead	Mercury	Cadmium	Hexavalent Chromium	Polybrominated Biphenyls	Polybrominated Diphenyl Ethers
	(Pb)	(Hg)	(Cd)	(Cr6)	(PBB)	(PBDE)
Maximum concentration	< .1%	< .1%	< .01%	< .1%	< .1%	< .1%

Fred Power
Operations Manager

Компания «Океан Электроники» предлагает заключение долгосрочных отношений при поставках импортных электронных компонентов на взаимовыгодных условиях!

Наши преимущества:

- Поставка оригинальных импортных электронных компонентов напрямую с производств Америки, Европы и Азии, а так же с крупнейших складов мира;
- Широкая линейка поставок активных и пассивных импортных электронных компонентов (более 30 млн. наименований);
- Поставка сложных, дефицитных, либо снятых с производства позиций;
- Оперативные сроки поставки под заказ (от 5 рабочих дней);
- Экспресс доставка в любую точку России;
- Помощь Конструкторского Отдела и консультации квалифицированных инженеров;
- Техническая поддержка проекта, помощь в подборе аналогов, поставка прототипов;
- Поставка электронных компонентов под контролем ВП;
- Система менеджмента качества сертифицирована по Международному стандарту ISO 9001;
- При необходимости вся продукция военного и аэрокосмического назначения проходит испытания и сертификацию в лаборатории (по согласованию с заказчиком);
- Поставка специализированных компонентов военного и аэрокосмического уровня качества (Xilinx, Altera, Analog Devices, Intersil, Interpoint, Microsemi, Actel, Aeroflex, Peregrine, VPT, Syfer, Eurofarad, Texas Instruments, MS Kennedy, Miteq, Cobham, E2V, MA-COM, Hittite, Mini-Circuits, General Dynamics и др.);

Компания «Океан Электроники» является официальным дистрибьютором и эксклюзивным представителем в России одного из крупнейших производителей разъемов военного и аэрокосмического назначения «JONHON», а так же официальным дистрибьютором и эксклюзивным представителем в России производителя высокотехнологичных и надежных решений для передачи СВЧ сигналов «FORSTAR».



JONHON

«JONHON» (основан в 1970 г.)

Разъемы специального, военного и аэрокосмического назначения:

(Применяются в военной, авиационной, аэрокосмической, морской, железнодорожной, горно- и нефтедобывающей отраслях промышленности)

«FORSTAR» (основан в 1998 г.)

ВЧ соединители, коаксиальные кабели, кабельные сборки и микроволновые компоненты:

(Применяются в телекоммуникациях гражданского и специального назначения, в средствах связи, РЛС, а так же военной, авиационной и аэрокосмической отраслях промышленности).



Телефон: 8 (812) 309-75-97 (многоканальный)

Факс: 8 (812) 320-03-32

Электронная почта: ocean@oceanchips.ru

Web: <http://oceanchips.ru/>

Адрес: 198099, г. Санкт-Петербург, ул. Калинина, д. 2, корп. 4, лит. А