

# MEMS Differential Pressure Sensor

## D6F-PH

### A Compact, High-accuracy Differential Pressure Sensor with Superior Resistance to Environments.

- High accuracy of  $\pm 3\%$  R.D.
- Linearized and temperature compensated
- Digital output (I<sup>2</sup>C communication)
- High flow impedance to reduce the influence of bypass configuration
- RoHS Compliant



## Ordering Information

Measurement Range	Applicable Fluid	Model
0 to 250 Pa (0 to 1 in. H <sub>2</sub> O)	Air	D6F-PH0025AD1
-50 to +50 Pa ( $\pm 0.2$ in. H <sub>2</sub> O)		D6F-PH0505AD3
-500 to +500 Pa ( $\pm 2$ in. H <sub>2</sub> O)		D6F-PH5050AD3

**Note:** The Sensor can be calibrated for different gas types. Consult Omron.

## Characteristics

Model	D6F-PH0025AD1	D6F-PH0505AD3	D6F-PH5050AD3
Measurement Range (See Note 1)	0 to 250 Pa	$\pm 50$ Pa	$\pm 500$ Pa
Calibration Gas (See Note 2)	Air		
Port Type	Barb joint, Maximum outside diameter: 4.9mm		
Power Supply	2.3 to 3.6 VDC		
Current Consumption	6 mA max. with no load and V <sub>CC</sub> of 3.3 V, GND=0 VDC, 25°C		
Resolution	12 bit		
Zero Point Tolerance (See Note 4)	$\pm 0.2$ Pa		
Span Tolerance (See Note 4)	$\pm 3\%$ R.D.		
Temperature Compensation	Yes		
Span shift due to Temperature Variation	$\pm 0.5\%$ R.D. per 10°C		
Response Time	25 ms typical at 12 bit resolution (50 ms max). The processing time is 6 ms typical at 12 bit resolution.		
Gas Flow through Sensor (See Note 3)	$\leq 63$ mL/min	$\leq 23$ mL/min	$\leq 100$ mL/min
Interface	I <sup>2</sup> C		
Case Material	PPS		
Degree of Protection	IEC IP40		
Withstand Pressure	10 kPa		
Operating Temperature	-20 to 80°C (with no condensation or icing)		
Operating Humidity	35 to 85% RH (with no condensation or icing)		
Storage Temperature	-40 to 80°C (with no condensation or icing)		
Storage Humidity	35 to 85% RH (with no condensation or icing)		
Insulation Resistance	Between Sensor outer cover and lead terminals: 20 M $\Omega$ min. (at 500 VDC)		
Dielectric Strength	Between Sensor outer cover and lead terminals: 500 VAC, 50/60 Hz min. for 1 min (leakage current: 1 mA max.)		
Weight	5.2 g		

- Note:**
1. At standard atmospheric pressure (1013.25 hPa).
  2. Dry gas must not contain large particles, e.g., dust, oil or mist.
  3. Type D6F-PH is based on thermal flow principle. Air flow is needed to measure the differential pressure. Typical characteristic of air flow by differential pressure is shown in the "Engineering Data" section.
  4. The zero point tolerance and span tolerance are independent uncertainties and add according to the principles of error propagation.

# Engineering Data

## Output Characteristics

D6F-PH0025AD1

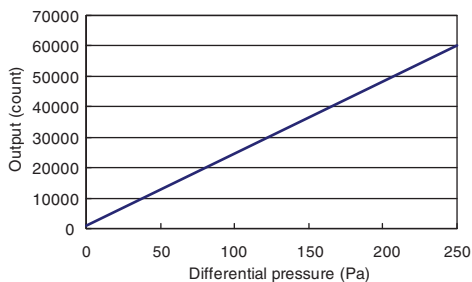

Differential pressure (Pa)	0	50	100	150	200	250
Output (Hex)	1024 (0x0400)	13024 (0x32E0)	25024 (0x61C0)	37024 (0x90A0)	49024 (0xBF80)	61024 (0xEE60)

Differential pressure conversion formula:  
 $DP = (Op - 1024) / 60000 \times 250$   
 DP = Differential pressure, OP = Output

D6F-PH0505AD3

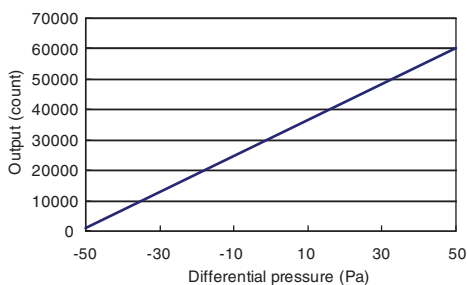

Differential pressure (Pa)	-50	-30	-10	0	10	30	50
Output (Hex)	1024 (0x0400)	13024 (0x32E0)	25024 (0x61C0)	31024 (0x7930)	37024 (0x90A0)	49024 (0xBF80)	61024 (0xEE60)

Differential pressure conversion formula:  
 $DP = (Op - 1024) / 60000 \times 100 - 50$   
 DP = Differential pressure, OP = Output

D6F-PH5050AD3

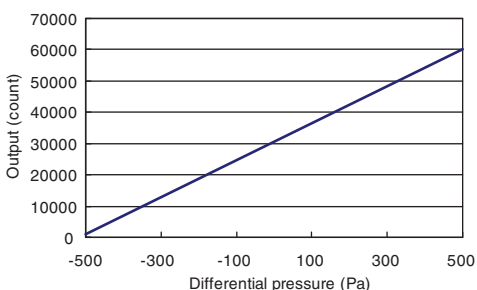

Differential pressure (Pa)	-500	-300	-100	0	100	300	500
Output (Hex)	1024 (0x0400)	11024 (0x2B10)	13024 (0x32E0)	16024 (0x3E98)	21024 (0x5220)	31024 (0x7930)	61024 (0xEE60)

Differential pressure conversion formula:  
 $DP = (Op - 1024) / 60000 \times 1000 - 500$   
 DP = Differential pressure, OP = Output

**Note:** Measurement conditions: Power supply voltage of  $3.3 \pm 0.1$  VDC, ambient temperature of  $25 \pm 5^\circ\text{C}$ , and ambient humidity of 25% to 75%.

## Relation Between Pressure and Flow Rate

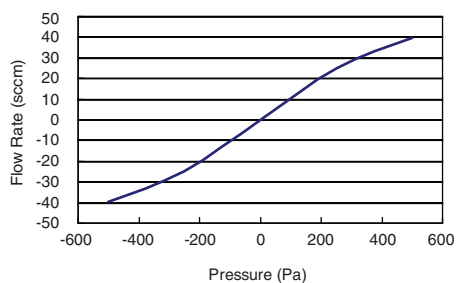

## Electrical Connection

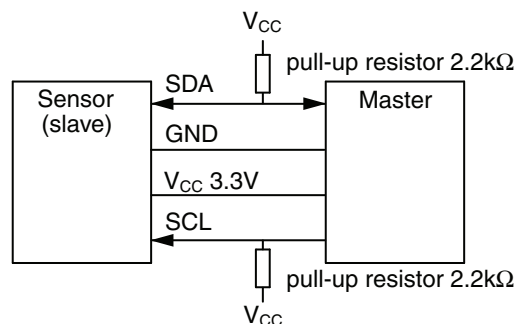

## Communication

Method	I <sup>2</sup> C	
Master/Slave	Slave / Address: HEX: 0x6C BIN: 110_1100 (7bit)	
Speed mode	Fast Mode 400kHz	
Signals		
	SCL	Serial Clock
	SDA	Data Signal

# Dimensions

(unit: mm)

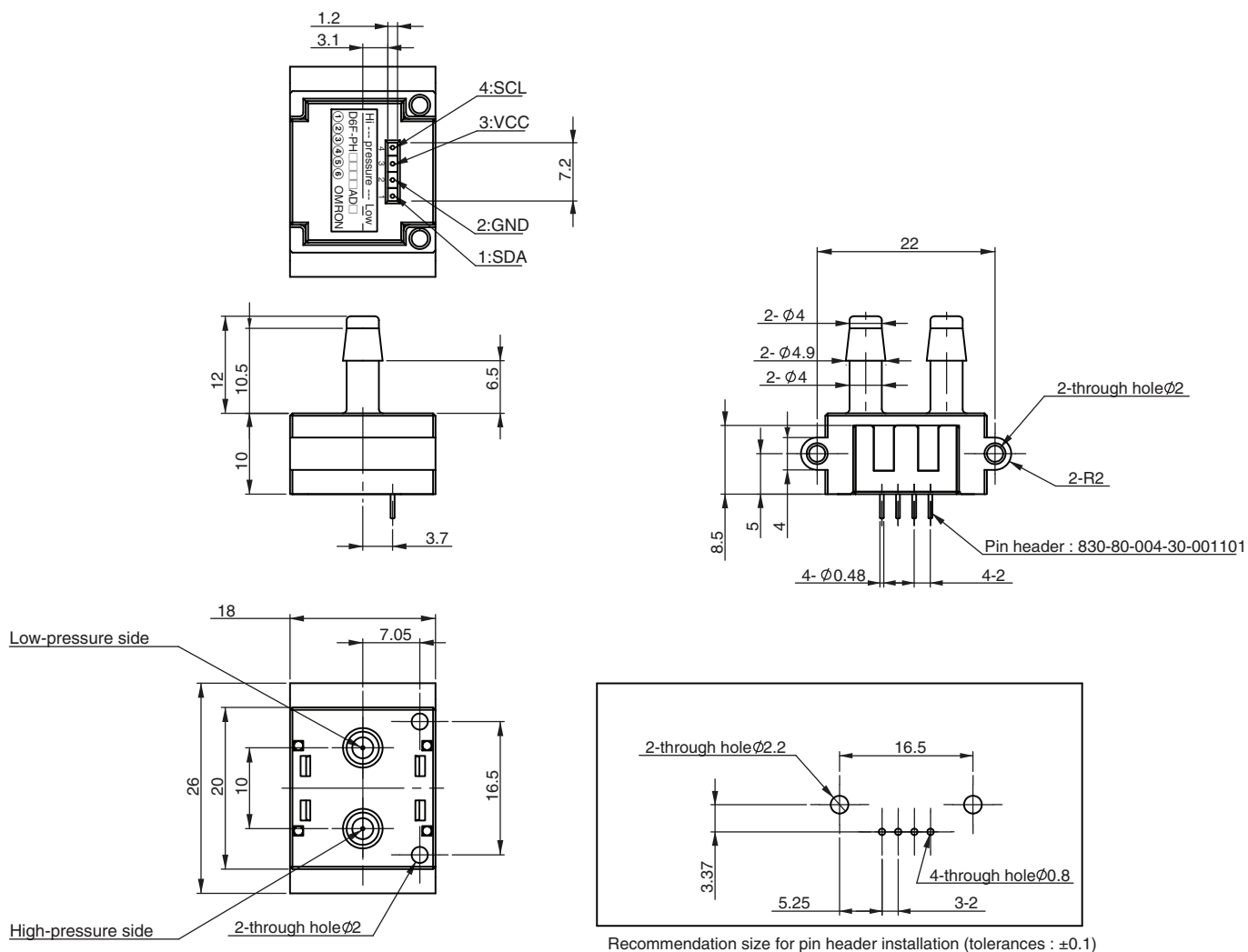

Recommendation size for pin header installation (tolerances :  $\pm 0.1$ )

# Precautions

## ⚠ WARNING

The D6F is built for use with general-purpose devices. In cases such as those described below, where safety is required, implement measures to ensure the safety of the system and all devices, such as fail-safe designs, redundancy designs, and regular maintenance.

- Safety devices for ensuring safety for persons
  - Transportation equipment control and Automotive control (such as applications to stop operation)
  - Aviation and space equipment
  - Nuclear power equipment
- Do not use the D6F for applications in which D6F operation would directly affect human life.

## ⚠ CAUTION

Make sure that the power to all equipment is turned OFF before you install the Sensor. Installing the Sensor while the power supply is ON may result in electrical shock or abnormal operation.

## ■ Correct Use

### Fluids, Tubes, and Sensor Installation

#### All Models

(1) Use clean fluids. Dust and mist can affect the characteristics of the Sensor or damage the Sensor. Install a filter and mist separator on the upstream tube.  
(Not required for the D6F-W□A1, D6F-P and D6F-PH.)

(2) Do not use combustible gases (e.g., hydrogen), corrosive gases (e.g., chlorine, sulfur, acidic, or alkali gas), or other non-approved fluids. They may damage the Sensor.

(3) The performance specifications that are given for the D6F do not apply if any fluids other than the specified applicable fluid are used.

(4) Foreign matter in the tubes that are connected to the Sensor may damage the Sensor. Prevent any foreign matter from entering the tubes after the Sensor is removed from its packaging.

(5) Attach the tubes so that fluid flows only in the direction designated by the "Hi/Low" pressure markings on the Sensor. Correct measurements cannot be obtained if the fluid flows in the wrong direction.

(6) We recommend that you install the tubes horizontally. If the tubes are not installed horizontally, an error of ±1% FS or higher may result. (This does not apply to the D6F-03A3.)

(7) Install the Sensor on a flat surface. Incorrect installation may damage the Sensor and make it impossible to obtain correct measurements.

(8) After the Sensor is installed, check to confirm that it operates correctly.

(9) Do not drop the Sensor, remove the cover, or attempt to disassemble the Sensor in any way.

#### D6F-PH0025AD1, D6F-PH0505AD3, and D6F-PH5050AD3

(1) Depending on the ambient environment and installation location, dust, dirt, and other foreign matter may come inside the Sensor and block a part or all of the flow path or accumulate on internal components. This may result in the Sensor not being able to perform to the specifications given above. Always perform a pre-evaluation on your actual equipment and be aware of the possible problems that may occur before you use the Sensor with the actual equipment.

(2) Attach all tubes so that the fluid flows only in the direction from the positive side (+) to the negative side (-).

(3) For PCB-mounting, perform terminal soldering only after the Sensor is secured into place on the PCB.

(4) Use M1.8 panhead screws or equivalent tapping screws to mount the Sensor, and tighten the screws to a maximum torque of 0.36 N·m.

(5) The sensor output is minimally affected with the length of a tube. The error is less than 1% with a tube (ID:4mm) length up to 800mm.

(6) Soldering

- Please solder properly
- Do not use flow soldering
- Please solder after fixed on the circuit board by screw
- Please use a soldering iron

Soldering condition	Pressure:	Max.100gf
	Temperature:	350 °C
	Time:	Max.5s

(7) About handling

- The sensor is a precision device, and if large shock and load is applied, it may cause a failure or characteristic change. Please do not use the sensor which has experienced excessive shock to the terminals, a damaged cover, or has fallen.
- The sensor shall only be handled in electrostatic discharge protected areas (EPA) under protected and controlled conditions.

### Operating Environment

Do not use the Sensor in the following locations:

- Locations directly subject to heat radiated from heating equipment
- Locations subject to water or oil
- Locations subject to direct sunlight
- Locations subject to intense temperature changes
- Locations subject to icing or condensation
- Locations subject to excessive vibration or shock

### Countermeasures against Noise

Noise may make it impossible to obtain correct measurements.

Consider the following countermeasures.

- Allow as much space as possible between the Sensor and devices that generate high frequencies (such as high-frequency welders and high-frequency sewing machines) or surges.
- Attach surge absorbers or noise filters to noise-generating devices that are near the Sensor (in particular, equipment with inductance, such as motors, transformers, solenoids, and magnetic coils).

(It also helps to separate pipes and ducts, and to use shielded cables.)

### Power Supply

- Do not directly solder power supply leads to the connector terminals. Use only the appropriate connectors.
- Wire with the correct terminal names and polarities. Incorrect wiring will cause failure of internal components.
- When using a commercially available switching regulator, ground the FG (frame ground) and G (ground) terminals.

### RoHS Directive

The RoHS mark is displayed on the packing of products for which the six substances banned by the RoHS Directive have been abolished (both in processing and in the electronic components mounted to the PCBs).

\*RoHS marking may be terminated if it is later determined that parts that were previously treated as RoHS compliant are not compliant due to circumstances at the supplier of the parts.

### RoHS Compliance Criteria

The following standards are used to determine RoHS compliance for the six banned substances. (Items to which the RoHS Directive is not applicable are not given.)

- Lead: 1,000 ppm max.
- Hexavalent chromium: 1,000 ppm max.
- Mercury: 1,000 ppm max.
- PBB: 1,000 ppm max.
- Cadmium: 100 ppm max.
- PBDE: 1,000 ppm max.

### Gas Density and Atmospheric Pressure

Change of gas density affects the sensor output.

Change of atmospheric pressure is compensated by the following formula:

$$D_{peff} = D_p \times (P_{std} / P_{amb})$$

$D_{peff}$ : Effective differential pressure

$D_p$ : Differential pressure of the sensor output

$P_{std}$ : Standard atmospheric pressure (1,013.25 hPa)

$P_{amb}$ : Actual ambient atmospheric pressure (hPa)

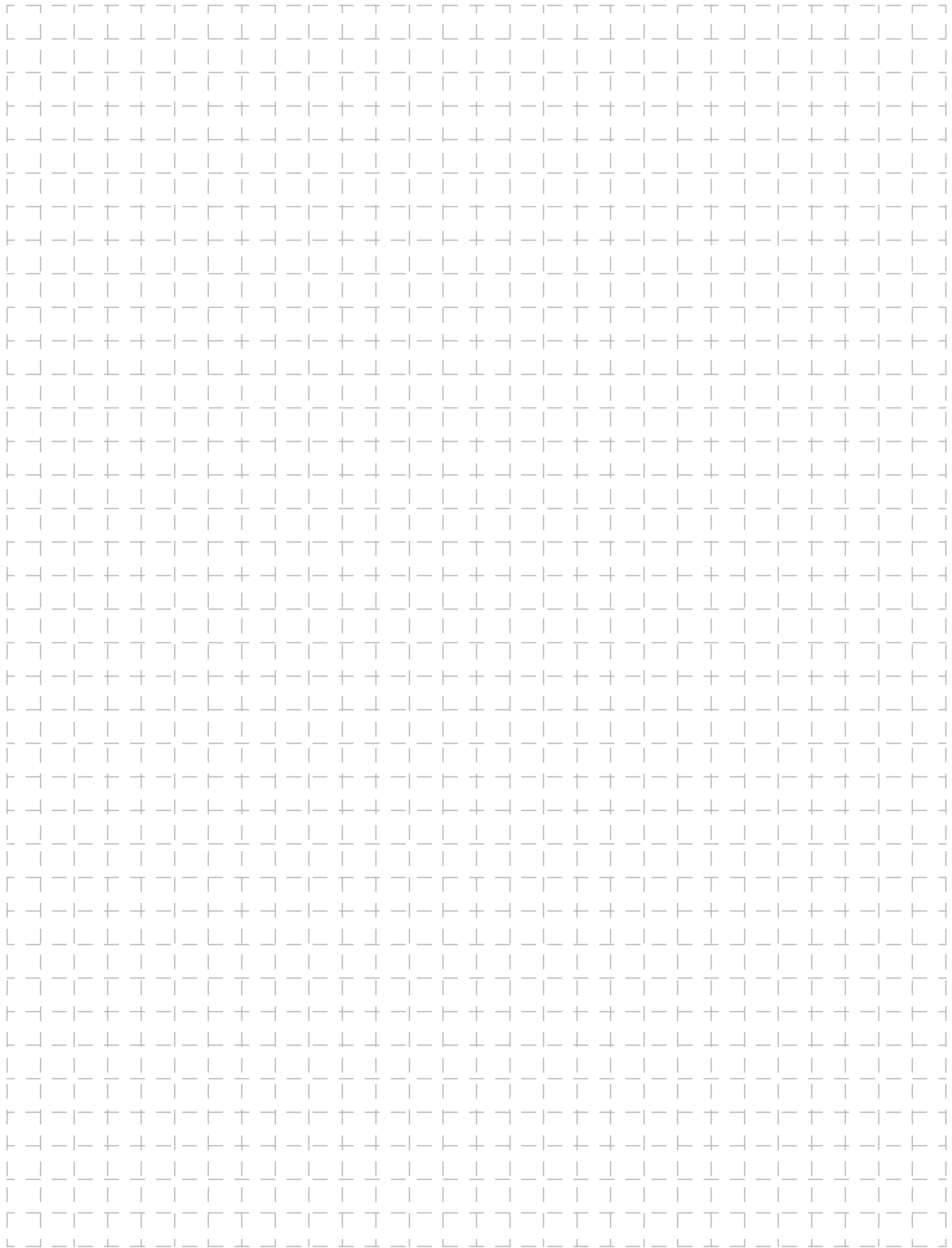

All sales are subject to Omron Electronic Components LLC standard terms and conditions of sale, which can be found at [http://www.components.omron.com/components/web/webfiles.nsf/sales\\_terms.html](http://www.components.omron.com/components/web/webfiles.nsf/sales_terms.html)

**ALL DIMENSIONS SHOWN ARE IN MILLIMETERS.**  
To convert millimeters into inches, multiply by 0.03937. To convert grams into ounces, multiply by 0.03527.

---

**OMRON**<sup>®</sup>

**OMRON ELECTRONIC  
COMPONENTS LLC**

55 E. Commerce Drive, Suite B  
Schaumburg, IL 60173

**847-882-2288**

**OMRON ON-LINE**

Global - <http://www.omron.com>

USA - <http://www.components.omron.com>

Cat. No. D6F-PH\_E\_ver.1

05/13

Specifications subject to change without notice

Printed in USA

Компания «Океан Электроники» предлагает заключение долгосрочных отношений при поставках импортных электронных компонентов на взаимовыгодных условиях!

Наши преимущества:

- Поставка оригинальных импортных электронных компонентов напрямую с производств Америки, Европы и Азии, а так же с крупнейших складов мира;
- Широкая линейка поставок активных и пассивных импортных электронных компонентов (более 30 млн. наименований);
- Поставка сложных, дефицитных, либо снятых с производства позиций;
- Оперативные сроки поставки под заказ (от 5 рабочих дней);
- Экспресс доставка в любую точку России;
- Помощь Конструкторского Отдела и консультации квалифицированных инженеров;
- Техническая поддержка проекта, помощь в подборе аналогов, поставка прототипов;
- Поставка электронных компонентов под контролем ВП;
- Система менеджмента качества сертифицирована по Международному стандарту ISO 9001;
- При необходимости вся продукция военного и аэрокосмического назначения проходит испытания и сертификацию в лаборатории (по согласованию с заказчиком);
- Поставка специализированных компонентов военного и аэрокосмического уровня качества (Xilinx, Altera, Analog Devices, Intersil, Interpoint, Microsemi, Actel, Aeroflex, Peregrine, VPT, Syfer, Eurofarad, Texas Instruments, MS Kennedy, Miteq, Cobham, E2V, MA-COM, Hittite, Mini-Circuits, General Dynamics и др.);

Компания «Океан Электроники» является официальным дистрибьютором и эксклюзивным представителем в России одного из крупнейших производителей разъемов военного и аэрокосмического назначения «JONHON», а так же официальным дистрибьютором и эксклюзивным представителем в России производителя высокотехнологичных и надежных решений для передачи СВЧ сигналов «FORSTAR».



## JONHON

«JONHON» (основан в 1970 г.)

Разъемы специального, военного и аэрокосмического назначения:

(Применяются в военной, авиационной, аэрокосмической, морской, железнодорожной, горно- и нефтедобывающей отраслях промышленности)

«FORSTAR» (основан в 1998 г.)

ВЧ соединители, коаксиальные кабели, кабельные сборки и микроволновые компоненты:

(Применяются в телекоммуникациях гражданского и специального назначения, в средствах связи, РЛС, а так же военной, авиационной и аэрокосмической отраслях промышленности).



Телефон: 8 (812) 309-75-97 (многоканальный)

Факс: 8 (812) 320-03-32

Электронная почта: [ocean@oceanchips.ru](mailto:ocean@oceanchips.ru)

Web: <http://oceanchips.ru/>

Адрес: 198099, г. Санкт-Петербург, ул. Калинина, д. 2, корп. 4, лит. А