

FEATURES

- Up or Downconverting Applications
- Noise Figure: 9.3dB Typical at 900MHz Output
- Conversion Gain: 2.4dB Typical
- IIP3: 9dBm Typical at $I_{CC} = 10\text{mA}$
- Adjustable Supply Current: 4mA to 13.4mA
- Low LO Drive Level: -2dBm
- Single-Ended or Differential LO
- High Port-to-Port Isolation
- Enable Control with Low Off-State Leakage Current
- Single 2.7V to 5V Supply
- Small 3mm × 3mm DFN Package

APPLICATIONS

- Portable Wireless
- CATV/DBS Receivers
- WiMAX Radios
- PHS Basestations
- RF Instrumentation
- Microwave Data Links
- VHF/UHF 2-Way Radios

DESCRIPTION

The LT[®]5560 is a low power, high performance broadband active mixer. This double-balanced mixer can be driven by a single-ended LO source and requires only -2dBm of LO power. The balanced design results in low LO leakage to the output, while the integrated input amplifier provides excellent LO to IN isolation. The signal ports can be impedance matched to a broad range of frequencies, which allows the LT5560 to be used as an up- or down-conversion mixer in a wide variety of applications.

The LT5560 is characterized with a supply current of 10mA; however, the DC current is adjustable, which allows the performance to be optimized for each application with a single resistor. For example, when biased at its maximum supply current (13.4mA), the typical upconverting mixer IIP3 is $+10.8\text{dBm}$ for a 900MHz output.

LT, LT, LTC and LTM are registered trademarks of Linear Technology Corporation. All other trademarks are the property of their respective owners.

TYPICAL APPLICATION

Low Cost 900MHz Downconverting Mixer

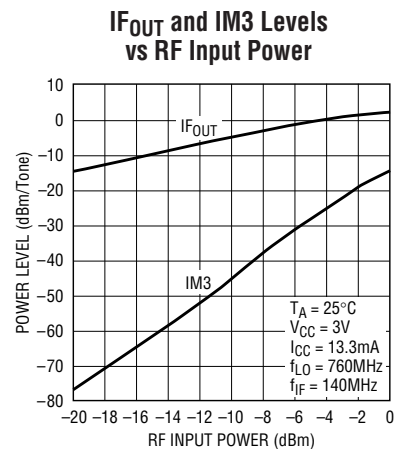
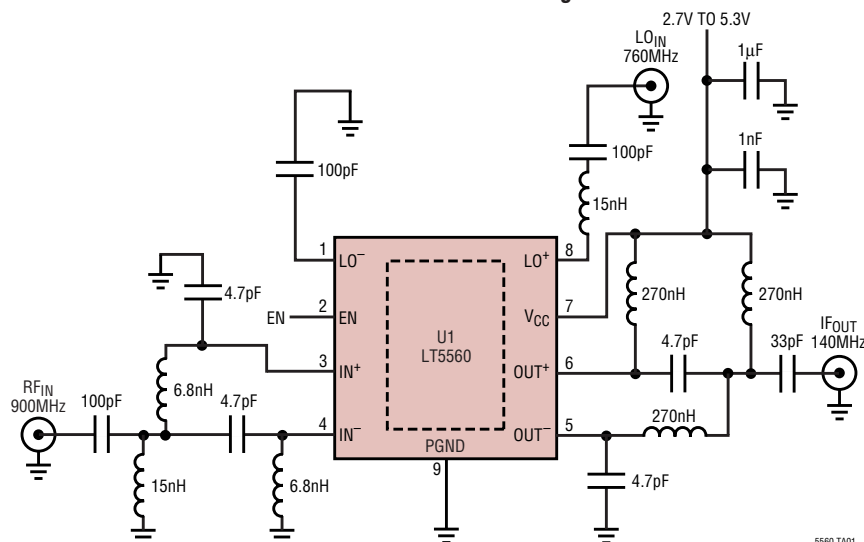

5560 TA02

5560 TA01

ABSOLUTE MAXIMUM RATINGS

(Note 1)

Supply Voltage	5.5V
Enable Voltage	-0.3V to $V_{CC} + 0.3V$
LO Input Power (Differential)	+10dBm
Input Signal Power (Differential)	+10dBm
IN^+ , IN^- DC Currents	10mA
OUT^+ , OUT^- DC Current	10mA
T_{JMAX}	125°C
Operating Temperature Range	-40°C to 85°C
Storage Temperature Range	-65°C to 125°C

PACKAGE/ORDER INFORMATION

TOP VIEW

DD PACKAGE
8-LEAD (3mm × 3mm) PLASTIC DFN

$T_{JMAX} = 125^{\circ}C$, $\theta_{JA} = 43^{\circ}C/W$
EXPOSED PAD (PIN 9) IS GND
MUST BE SOLDERED TO PCB

ORDER PART NUMBER	DD PART MARKING
LT5560EDD	LCBX

Order Options Tape and Reel: Add #TR
Lead Free: Add #PBF Lead Free Tape and Reel: Add #TRPBF
Lead Free Part Marking: <http://www.linear.com/leadfree/>

Consult LTC Marketing for parts specified with wider operating temperature ranges.

DC ELECTRICAL CHARACTERISTICS

$V_{CC} = 3V$, $EN = 3V$, $T_A = 25^{\circ}C$, unless otherwise noted. Test circuit shown in Figure 1. (Note 3)

PARAMETER	CONDITIONS	MIN	TYP	MAX	UNITS
Power Supply Requirements (V_{CC})					
Supply Voltage		2.7	3	5.3	V
Supply Current	$V_{CC} = 3V$, $R1 = 3\Omega$		10	12	mA
Shutdown Current	$EN = 0.3V$, $V_{CC} = 3V$		0.1	10	μA
Enable (EN) Low = Off, High = On					
EN Input High Voltage (On)		2			V
EN Input Low Voltage (Off)				0.3	V
Enable Pin Input Current	$EN = 3V$ $EN = 0.3V$		25 0.1		μA μA
Turn On Time			2		μs
Turn Off Time			5		μs

AC ELECTRICAL CHARACTERISTICS (Notes 2 and 3)

PARAMETER	CONDITIONS	MIN	TYP	MAX	UNITS
Signal Input Frequency Range (Note 4)	Requires External Matching		< 4000		MHz
LO Input Frequency Range (Note 4)	Requires External Matching		< 4000		MHz
Signal Output Frequency Range (Note 4)	Requires External Matching		< 4000		MHz

5560f

AC ELECTRICAL CHARACTERISTICS

$V_{CC} = 3V$, $EN = 3V$, $T_A = 25^\circ C$, $P_{IN} = -20dBm$ ($-20dBm/$ tone for 2-tone IIP3 tests, $\Delta f = 1MHz$), $P_{LO} = -2dBm$, unless otherwise noted. Test circuits are shown in Figures 1, 2 and 3. (Notes 2 and 3)

PARAMETER	CONDITIONS	MIN	TYP	MAX	UNITS
Signal Input Return Loss	$Z = 50\Omega$, External Match		15		dB
LO Input Return Loss	$Z = 50\Omega$, External Match		15		dB
Signal Output Return Loss	$Z = 50\Omega$, External Match		15		dB
LO Input Power			-6 to 1		dBm

Upconverting Mixer Configuration: $V_{CC} = 3V$, $EN = 3V$, $T_A = 25^\circ C$, $P_{IN} = -20dBm$ ($-20dBm/$ tone for 2-tone IIP3 tests, $\Delta f = 1MHz$), $P_{LO} = -2dBm$, unless otherwise noted. High side LO for 450MHz tests, low side LO for 900MHz and 1900MHz tests. Test circuits are shown in Figures 1 and 3. (Notes 2, 3 and 5)

PARAMETER	CONDITIONS	MIN	TYP	MAX	UNITS
Conversion Gain	$f_{IN} = 70MHz$, $f_{OUT} = 450MHz$		2.7		dB
	$f_{IN} = 140MHz$, $f_{OUT} = 900MHz$		2.4		dB
	$f_{IN} = 140MHz$, $f_{OUT} = 1900MHz$		1.2		dB
Conversion Gain vs Temperature	$T_A = -40^\circ C$ to $85^\circ C$, $f_{OUT} = 900MHz$		-0.015		dB/ $^\circ C$
Input 3rd Order Intercept	$f_{IN} = 70MHz$, $f_{OUT} = 450MHz$		9.6		dBm
	$f_{IN} = 140MHz$, $f_{OUT} = 900MHz$		9.0		dBm
	$f_{IN} = 140MHz$, $f_{OUT} = 1900MHz$		8.0		dBm
Input 2nd Order Intercept	$f_{IN} = 70MHz$, $f_{OUT} = 450MHz$		46		dBm
	$f_{IN} = 140MHz$, $f_{OUT} = 900MHz$		47		dBm
	$f_{IN} = 140MHz$, $f_{OUT} = 1900MHz$		30		dBm
Single Sideband Noise Figure	$f_{IN} = 70MHz$, $f_{OUT} = 450MHz$		8.8		dB
	$f_{IN} = 140MHz$, $f_{OUT} = 900MHz$		9.3		dB
	$f_{IN} = 140MHz$, $f_{OUT} = 1900MHz$		10.3		dB
IN to LO Isolation (with LO Applied)	$f_{IN} = 70MHz$, $f_{OUT} = 450MHz$		69		dB
	$f_{IN} = 140MHz$, $f_{OUT} = 900MHz$		64		dB
	$f_{IN} = 140MHz$, $f_{OUT} = 1900MHz$		64		dB
LO to IN Leakage	$f_{IN} = 70MHz$, $f_{OUT} = 450MHz$		-63		dBm
	$f_{IN} = 140MHz$, $f_{OUT} = 900MHz$		-54		dBm
	$f_{IN} = 140MHz$, $f_{OUT} = 1900MHz$		-36		dBm
LO to OUT Leakage	$f_{IN} = 70MHz$, $f_{OUT} = 450MHz$		-44		dBm
	$f_{IN} = 140MHz$, $f_{OUT} = 900MHz$		-41		dBm
	$f_{IN} = 140MHz$, $f_{OUT} = 1900MHz$		-36		dBm
Input 1dB Compression Point	$f_{IN} = 70MHz$, $f_{OUT} = 450MHz$		0.4		dBm
	$f_{IN} = 140MHz$, $f_{OUT} = 900MHz$		-2.8		dBm
	$f_{IN} = 140MHz$, $f_{OUT} = 1900MHz$		-0.8		dBm

Downconverting Mixer Configuration: $V_{CC} = 3V$, $EN = 3V$, $T_A = 25^\circ C$, $P_{IN} = -20dBm$ ($-20dBm/$ tone for 2-tone IIP3 tests, $\Delta f = 1MHz$), $P_{LO} = -2dBm$, unless otherwise noted. High side LO for 450MHz tests, low side LO for 900MHz and 1900MHz tests. Test circuits are shown in Figures 2 and 3. (Notes 2, 3 and 5)

PARAMETER	CONDITIONS	MIN	TYP	MAX	UNITS
Conversion Gain	$f_{IN} = 450MHz$, $f_{OUT} = 70MHz$		2.7		dB
	$f_{IN} = 900MHz$, $f_{OUT} = 140MHz$		2.6		dB
	$f_{IN} = 1900MHz$, $f_{OUT} = 140MHz$		2.3		dB
Conversion Gain vs Temperature	$T_A = -40^\circ C$ to $85^\circ C$, $f_{IN} = 900MHz$		-0.015		dB/ $^\circ C$
Input 3rd Order Intercept	$f_{IN} = 450MHz$, $f_{OUT} = 70MHz$		10.1		dBm
	$f_{IN} = 900MHz$, $f_{OUT} = 140MHz$		9.7		dBm
	$f_{IN} = 1900MHz$, $f_{OUT} = 140MHz$		5.6		dBm
Single Sideband Noise Figure	$f_{IN} = 450MHz$, $f_{OUT} = 70MHz$		10.5		dB
	$f_{IN} = 900MHz$, $f_{OUT} = 140MHz$		10.1		dB
	$f_{IN} = 1900MHz$, $f_{OUT} = 140MHz$		10.8		dB

AC ELECTRICAL CHARACTERISTICS

Downconverting Mixer Configuration: $V_{CC} = 3V$, $EN = 3V$, $T_A = 25^{\circ}C$, $P_{IN} = -20dBm$ (-20dBm/tone for 2-tone IIP3 tests, $\Delta f = 1MHz$), $P_{LO} = -2dBm$, unless otherwise noted. High side LO for 450MHz tests, low side LO for 900MHz and 1900MHz tests. Test circuits are shown in Figures 2 and 3. (Notes 2, 3 and 5)

PARAMETER	CONDITIONS	MIN	TYP	MAX	UNITS
IN to LO Isolation (with LO Applied)	$f_{IN} = 450MHz, f_{OUT} = 70MHz$		52		dB
	$f_{IN} = 900MHz, f_{OUT} = 140MHz$		52		dB
	$f_{IN} = 1900MHz, f_{OUT} = 140MHz$		25		dB
LO to IN Leakage	$f_{IN} = 450MHz, f_{OUT} = 70MHz$		-52		dBm
	$f_{IN} = 900MHz, f_{OUT} = 140MHz$		-57		dBm
	$f_{IN} = 1900MHz, f_{OUT} = 140MHz$		-37		dBm
LO to OUT Leakage	$f_{IN} = 450MHz, f_{OUT} = 70MHz$		-47		dBm
	$f_{IN} = 900MHz, f_{OUT} = 140MHz$		-63		dBm
	$f_{IN} = 1900MHz, f_{OUT} = 140MHz$		-24		dBm
2RF – 2LO Output Spurious (Half IF) Product ($f_{IN} = f_{LO} + f_{OUT}/2$)	450MHz: $f_{IN} = 485MHz, f_{OUT} = 70MHz$		-68		dBc
	900MHz: $f_{IN} = 830MHz, f_{OUT} = 140MHz$		-69		dBc
	1900MHz: $f_{IN} = 1830MHz, f_{OUT} = 140MHz$		-47		dBc
3RF – 3LO Output Spurious (1/3 IF) Product ($f_{IN} = f_{LO} + f_{OUT}/3$)	450MHz: $f_{IN} = 496.7MHz, f_{OUT} = 69.9MHz$		-79		dBc
	900MHz: $f_{IN} = 806.7MHz, f_{OUT} = 140.1MHz$		-76		dBc
	1900MHz: $f_{IN} = 1806.7MHz, f_{OUT} = 140.1MHz$		-62		dBc
Input 1dB Compression Point	$f_{IN} = 450MHz, f_{OUT} = 70MHz$		-0.8		dBm
	$f_{IN} = 900MHz, f_{OUT} = 140MHz$		0		dBm
	$f_{IN} = 1900MHz, f_{OUT} = 140MHz$		-2.2		dBm

Note 1: Stresses beyond those listed under Absolute Maximum Ratings may cause permanent damage to the device. Exposure to any Absolute Maximum Rating condition for extended periods may affect device reliability and lifetime.

Note 2: Each set of frequency conditions requires an appropriate test board.

Note 3: Specifications over the -40°C to +85°C temperature range are assured by design, characterization and correlation with statistical process controls.

Note 4: Operation over a wider frequency range is possible with reduced performance. Consult the factory for information and assistance.

Note 5: SSB Noise Figure measurements are performed with a small-signal noise source and bandpass filter on the RF input (downmixer) or output (upmixer), and no other RF input signal applied.

TYPICAL DC PERFORMANCE CHARACTERISTICS (Test Circuit Shown in Figure 1)

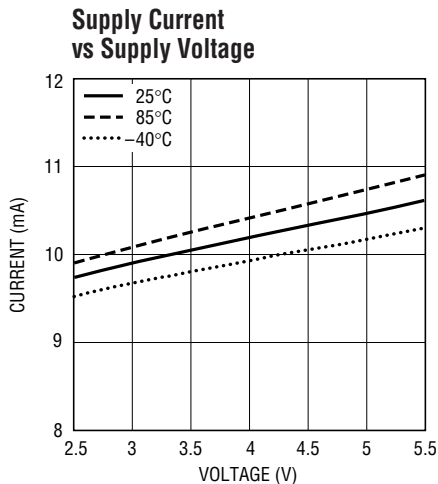

5560 G01

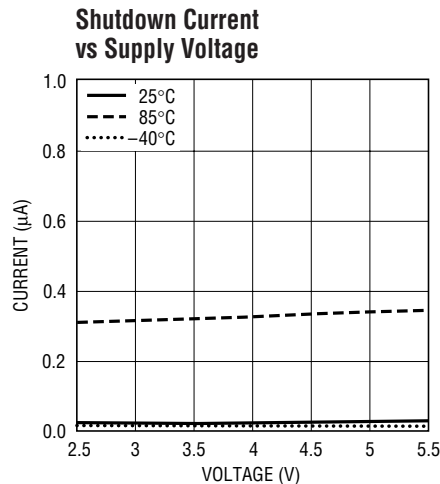

5560 G02

5560f

TYPICAL AC PERFORMANCE CHARACTERISTICS

900MHz Upconverting Mixer Application:

$V_{CC} = 3V$, $I_{CC} = 10mA$, $EN = 3V$, $T_A = 25^\circ C$, $f_{IN} = 140MHz$, $P_{IN} = -20dBm$ ($-20dBm$ /tone for 2-tone IIP3 tests, $\Delta f = 1MHz$), $f_{LO} = 760MHz$, $P_{LO} = -2dBm$, output measured at 900MHz, unless otherwise noted. (Test circuit shown in Figure 1)

Conversion Gain, IIP3 and SSB NF vs RF Output Frequency

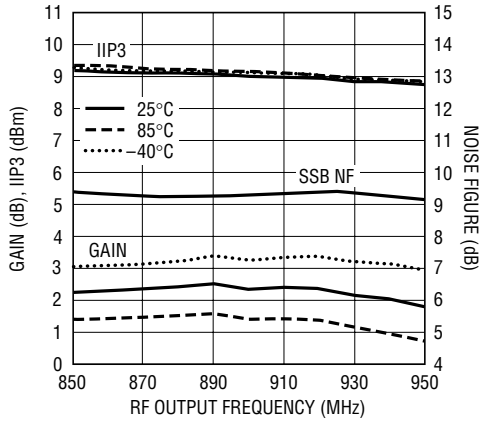

5560 G03

Conversion Gain and IIP3 vs LO Input Power

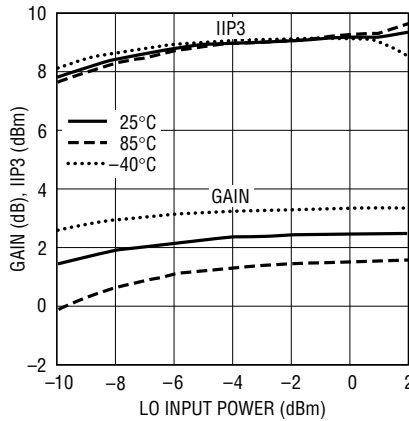

5560 G04

SSB Noise Figure vs LO Input Power

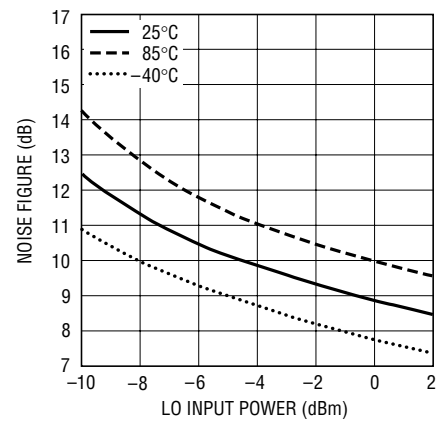

5560 G05

LO-IN and LO-OUT Leakage vs LO Frequency

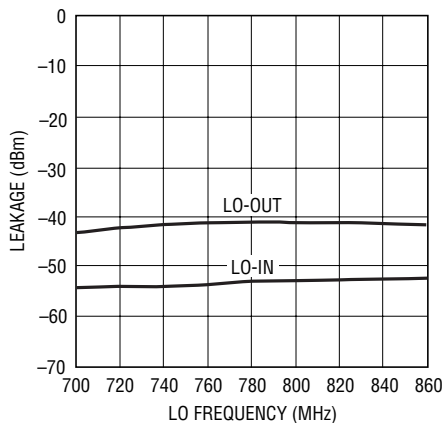

5560 G06

Conversion Gain and IIP3 vs Supply Voltage

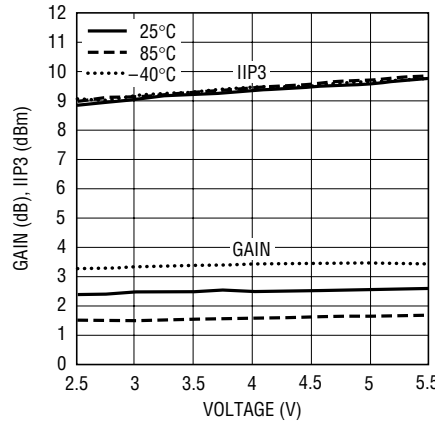

5560 G07

RFOUT, IM3 and IM2 vs IF Input Power (Two Input Tones)

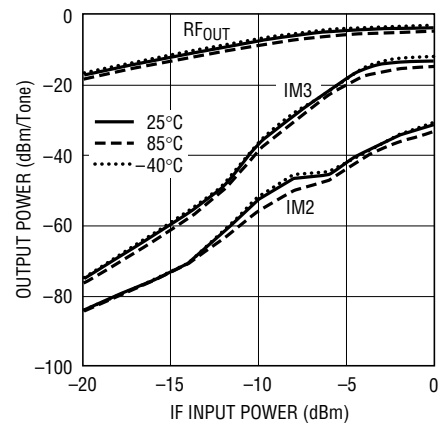

5560 G08

Gain Distribution at 900MHz

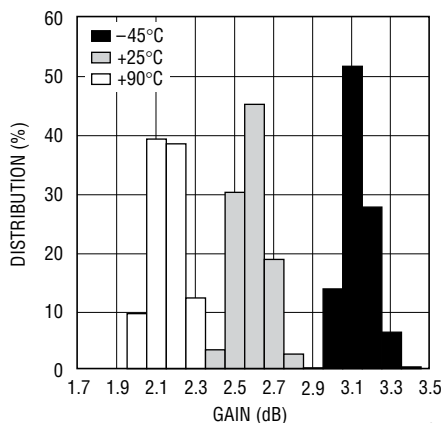

5560 G09

IIP3 Distribution at 900MHz

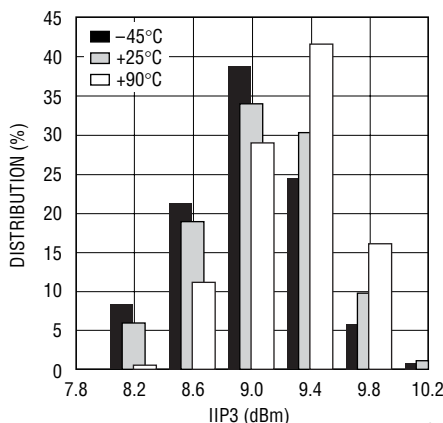

5560 G10

SSB Noise Figure Distribution at 900MHz

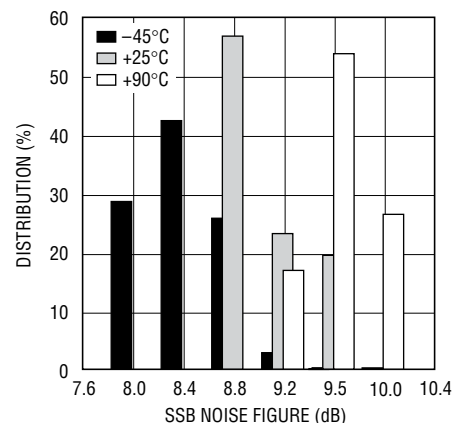

5560 G11

TYPICAL AC PERFORMANCE CHARACTERISTICS

450MHz Upconverting Mixer Application:

$V_{CC} = 3V$, $I_{CC} = 10mA$, $EN = 3V$, $T_A = 25^\circ C$, $f_{IN} = 70MHz$, $P_{IN} = -20dBm$ (-20dBm/tone for 2-tone IIP3 tests, $\Delta f = 1MHz$), $f_{LO} = 520MHz$, $P_{LO} = -2dBm$, output measured at 450MHz, unless otherwise noted. (Test circuit shown in Figure 3)

Conversion Gain and IIP3 vs RF Output Frequency

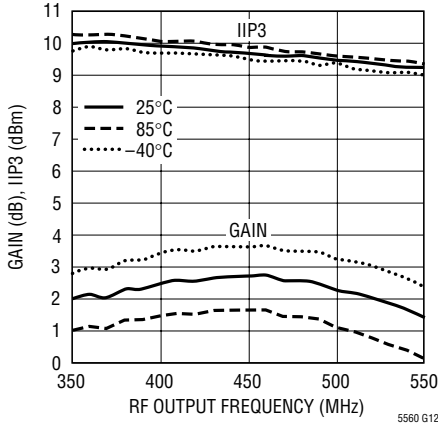

SSB Noise Figure vs RF Output Frequency

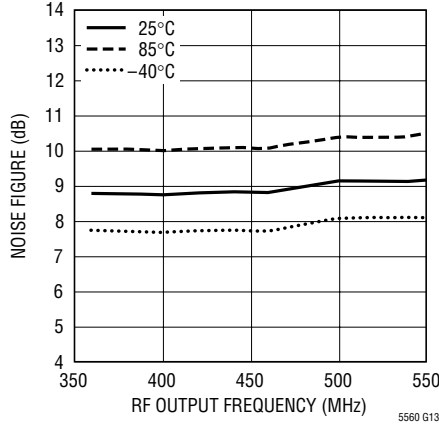

RF_{OUT}, IM3 and IM2 vs IF Input Power (Two Input Tones)

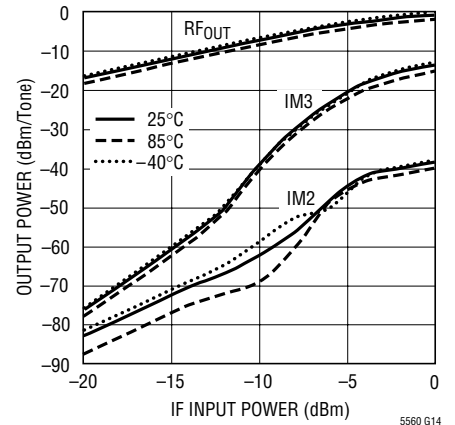

Conversion Gain and IIP3 vs LO Input Power

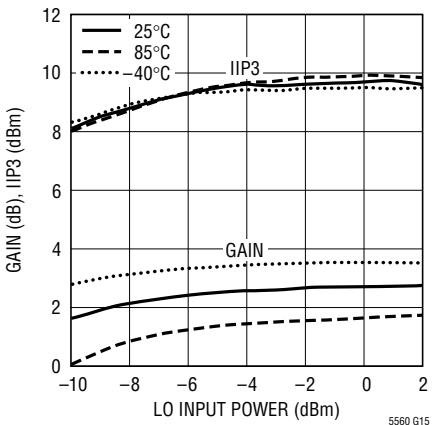

SSB Noise Figure vs LO Input Power

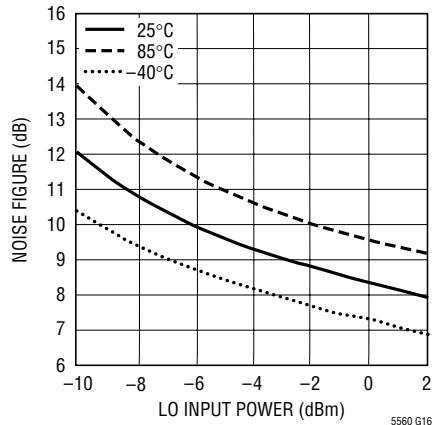

LO-IN and LO-OUT Leakage vs LO Frequency

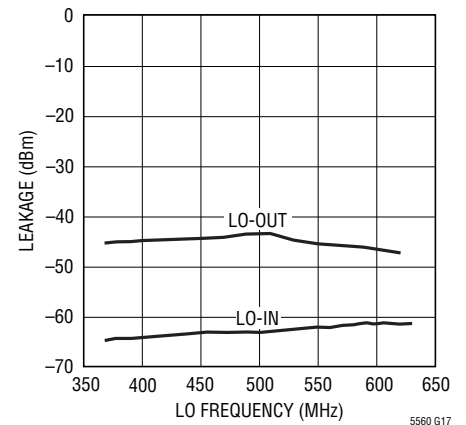

1900MHz Upconverting Mixer Application: $V_{CC} = 3V$, $I_{CC} = 10mA$, $EN = 3V$, $T_A = 25^\circ C$, $f_{IN} = 140MHz$, $P_{IN} = -20dBm$ (-20dBm/tone for 2-tone IIP3 tests, $\Delta f = 1MHz$), $f_{LO} = 1760MHz$, $P_{LO} = -2dBm$, output measured at 1900MHz, unless otherwise noted. (Test circuit shown in Figure 1)

Conversion Gain and IIP3 vs RF Output Frequency

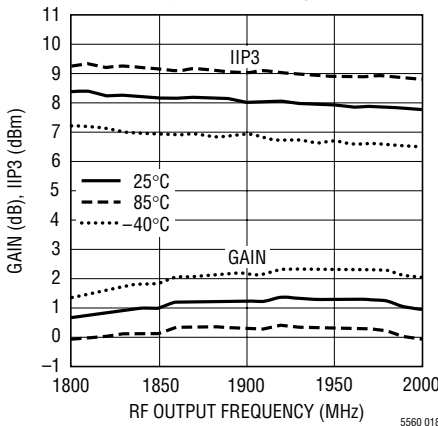

SSB Noise Figure vs RF Output Frequency

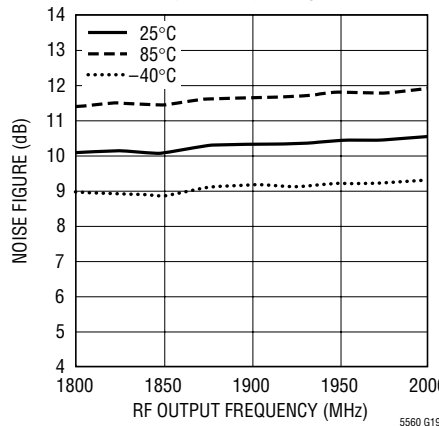

RF_{OUT}, IM3 and IM2 vs IF Input Power (Two Input Tones)

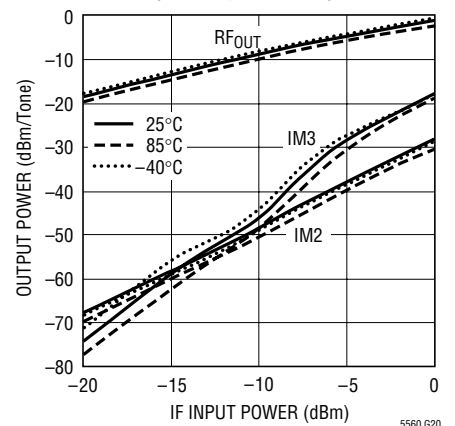

TYPICAL AC PERFORMANCE CHARACTERISTICS

1900MHz Upconverting Mixer Application:
 $V_{CC} = 3V$, $I_{CC} = 10mA$, $V_{EN} = 3V$, $T_A = 25^\circ C$, $f_{IN} = 140MHz$, $P_{IN} = -20dBm$ (-20dBm/tone for 2-tone IIP3 tests, $\Delta f = 1MHz$), $f_{LO} = 1760MHz$, $P_{LO} = -2dBm$, output measured at 1900MHz, unless otherwise noted. (Test circuit shown in Figure 1)

Conversion Gain and IIP3 vs LO Input Power

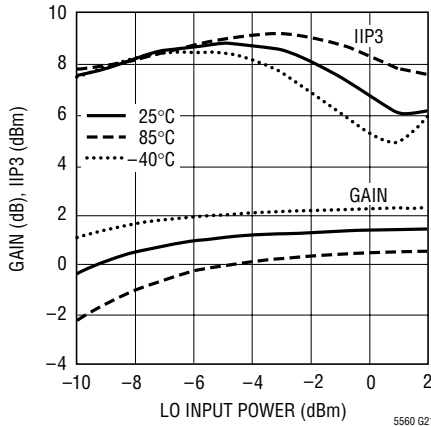

5560 G21

SSB Noise Figure vs LO Input Power

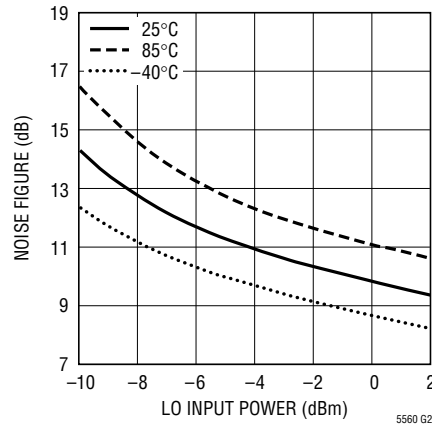

5560 G22

LO-IN and LO-OUT Leakage vs LO Frequency

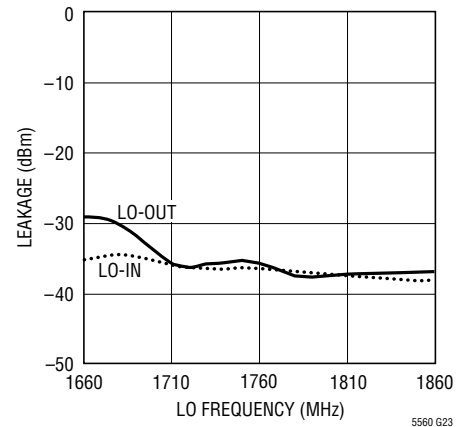

5560 G23

900MHz Downconverting Mixer Application: $V_{CC} = 3V$, $I_{CC} = 10mA$, $V_{EN} = 3V$, $T_A = 25^\circ C$, $f_{IN} = 900MHz$, $P_{IN} = -20dBm$ (-20dBm/tone for 2-tone IIP3 tests, $\Delta f = 1MHz$), $f_{LO} = 760MHz$, $P_{LO} = -2dBm$, output measured at 140MHz, unless otherwise noted. (Test circuit shown in Figure 2)

Conversion Gain, IIP3 and SSB NF vs RF Input Frequency

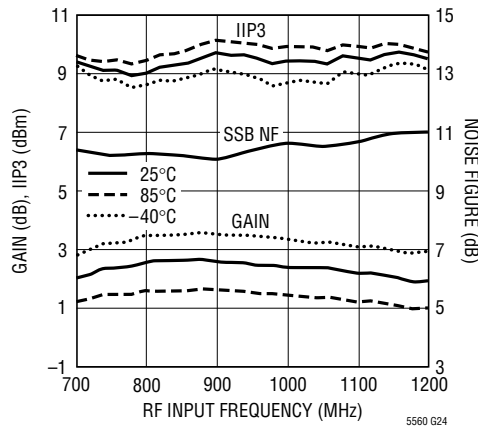

5560 G24

Conversion Gain and IIP3 vs LO Input Power

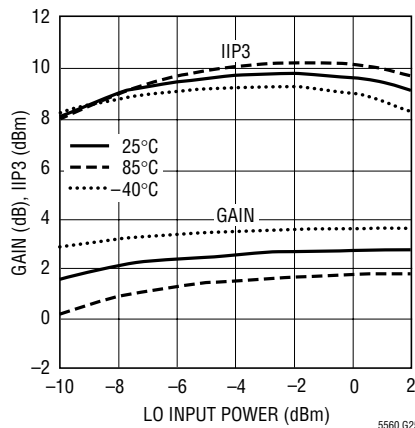

5560 G25

SSB Noise Figure vs LO Input Power

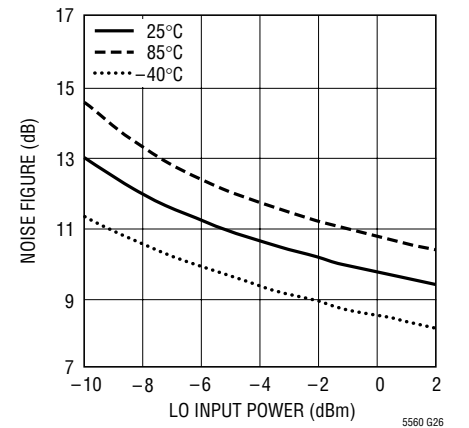

5560 G26

LO-IN and LO-OUT Leakage vs LO Frequency

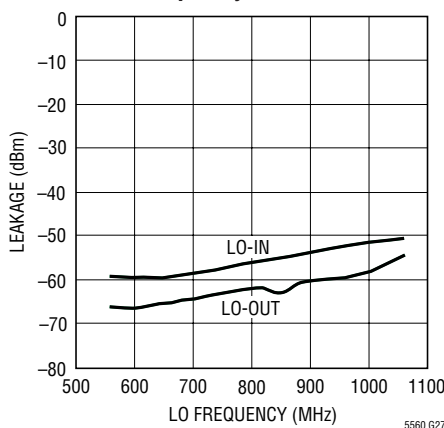

5560 G27

I_{FOUT}, 2 × 2 and 3 × 3 Spurs vs RF Input Power (Single Input Tone)

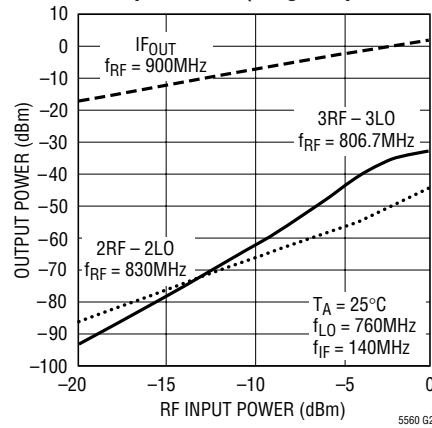

5560 G28

2 × 2 and 3 × 3 Spurs vs LO Input Power (Single Input Tone)

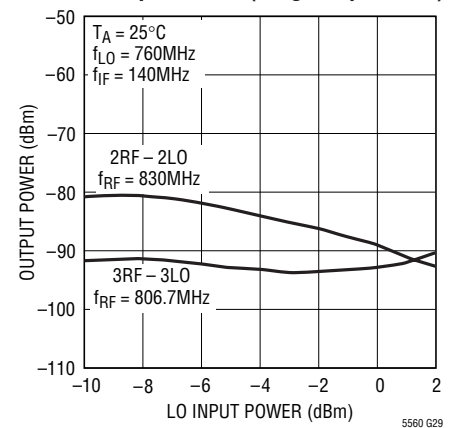

5560 G29

5560F

TYPICAL AC PERFORMANCE CHARACTERISTICS 900MHz Downconverting Mixer Application: $V_{CC} = 3V$, $I_{CC} = 10mA$, $EN = 3V$, $T_A = 25^\circ C$, $f_{IN} = 900MHz$, $P_{IN} = -20dBm$ ($-20dBm/$ tone for 2-tone IIP3 tests, $\Delta f = 1MHz$), $f_{LO} = 760MHz$, $P_{LO} = -2dBm$, output measured at 140MHz, unless otherwise noted. (Test circuit shown in Figure 2)

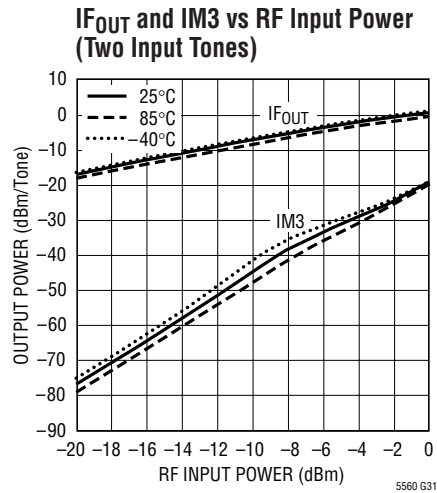
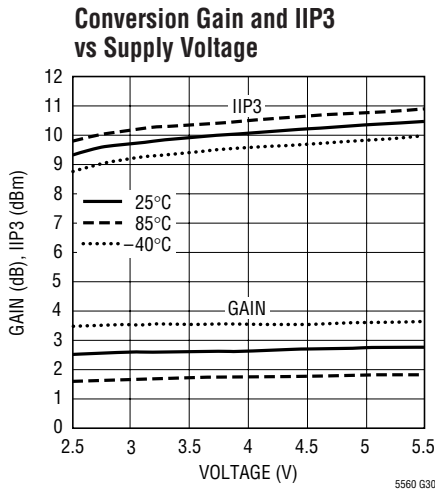

450MHz Downconverting Mixer Application: $V_{CC} = 3V$, $I_{CC} = 10mA$, $EN = 3V$, $T_A = 25^\circ C$, $f_{IN} = 450MHz$, $P_{IN} = -20dBm$ ($-20dBm/$ tone for 2-tone IIP3 tests, $\Delta f = 1MHz$), $f_{LO} = 520MHz$, $P_{LO} = -2dBm$, output measured at 70MHz, unless otherwise noted. (Test circuit shown in Figure 3)

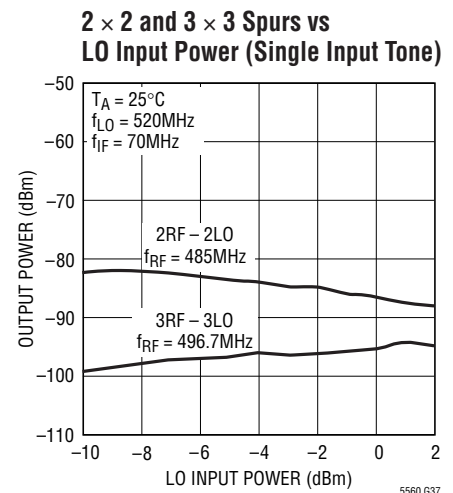
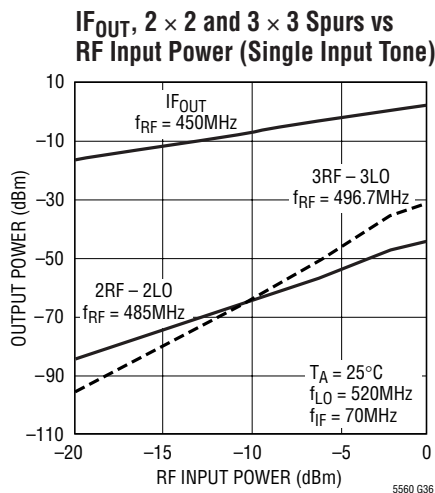
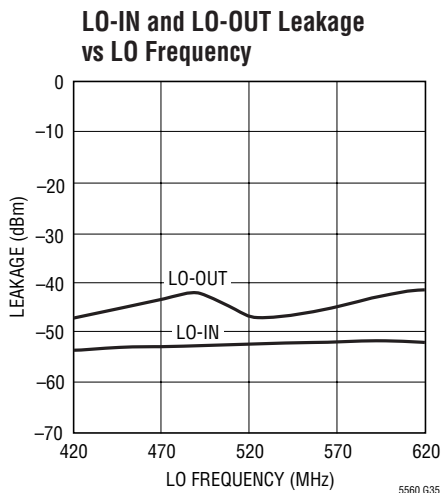
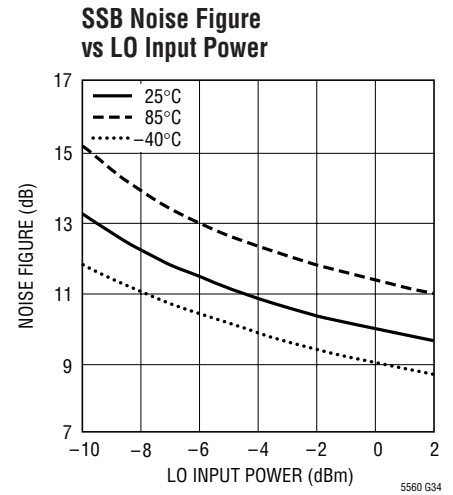
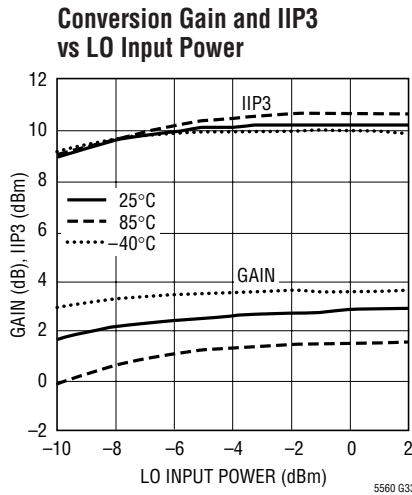
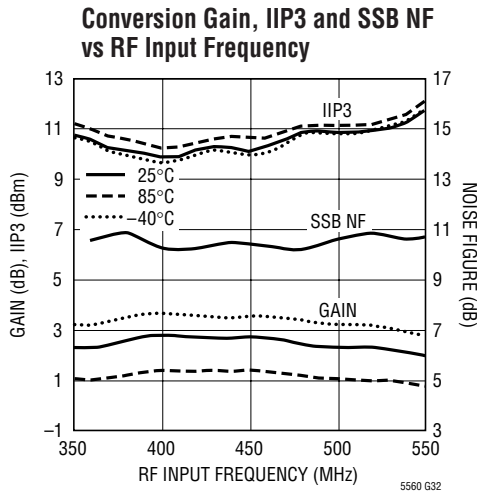

TYPICAL AC PERFORMANCE CHARACTERISTICS 1900MHz Downconverting Mixer Application:
 $V_{CC} = 3V$, $I_{CC} = 10mA$, $EN = 3V$, $T_A = 25^\circ C$, $f_{IN} = 1900MHz$, $P_{IN} = -20dBm$ (-20dBm/tone for 2-tone IIP3 tests, $\Delta f = 1MHz$),
 $f_{LO} = 1760MHz$, $P_{LO} = -2dBm$, output measured at 140MHz, unless otherwise noted. (Test circuit shown in Figure 2)

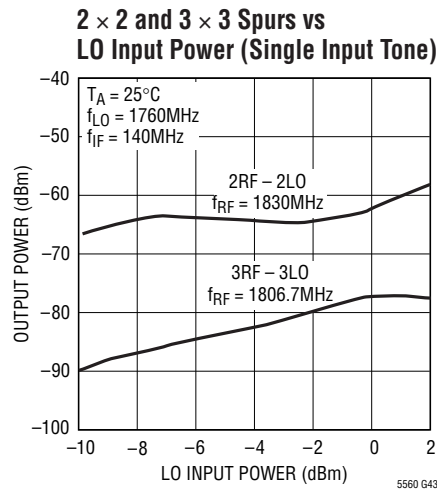
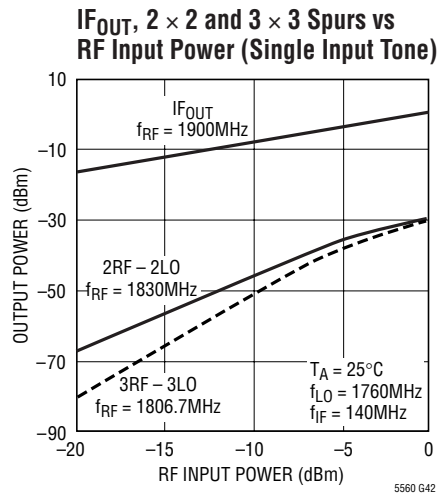
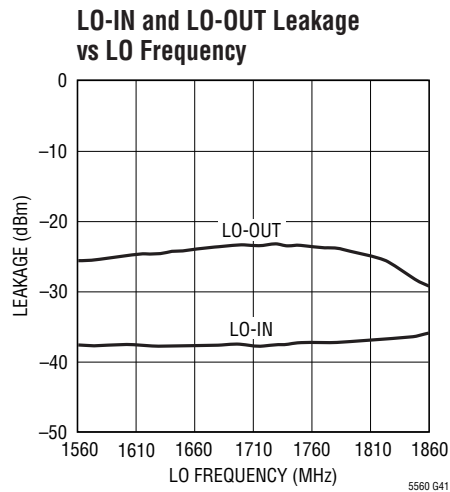
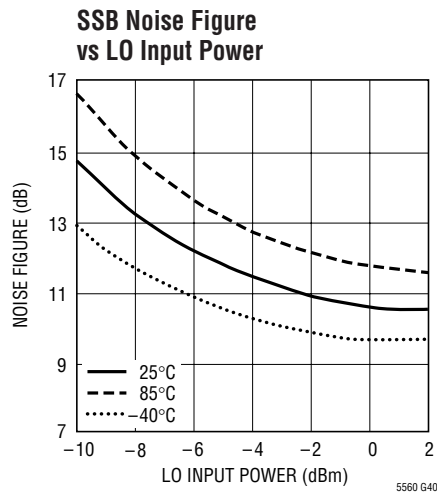
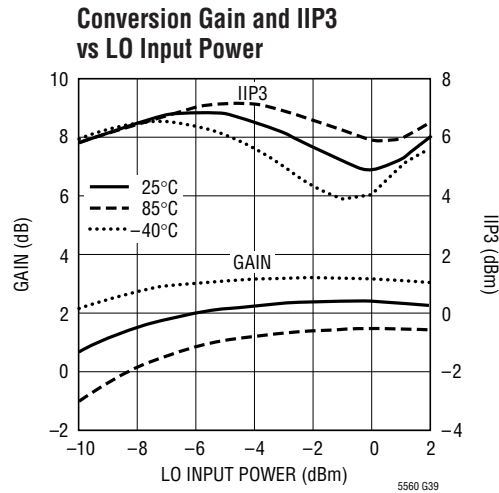
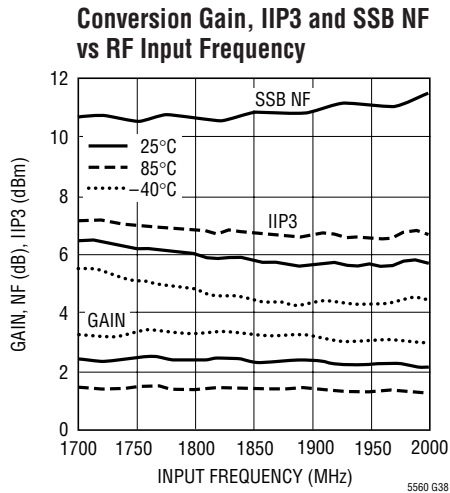

PIN FUNCTIONS

LO⁻, LO⁺ (Pins 1, 8): Differential Inputs for the Local Oscillator Signal. The LO input impedance is approximately 180Ω, thus external impedance matching is required. The LO pins are internally biased to approximately 1V below V_{CC}; therefore, DC blocking capacitors are required. The LT5560 is characterized and production tested with a single-ended LO drive, though a differential LO drive can be used.

EN (Pin 2): Enable Pin. An applied voltage above 2V will activate the IC. For V_{EN} below 0.3V, the IC will be shut down. If the enable function is not required, then this pin should be connected to V_{CC}. The typical enable pin input current is 25μA for EN = 3V. The enable pin should not be allowed to float because the mixer may not turn on reliably. Note that at no time should the EN pin voltage be allowed to exceed V_{CC} by more than 0.3V.

IN⁺, IN⁻ (Pins 3, 4): Differential Inputs. These pins should be driven with a differential signal for optimum performance.

Each pin requires a DC current path to ground. Resistance to ground will cause a decrease in the mixer current. With 0Ω resistance, approximately 6mA of DC current flows out of each pin. For lowest LO leakage to the output, the DC resistance from each pin to ground should be equal. An impedance transformation is required to match the differential input to the desired source impedance.

OUT⁻, OUT⁺ (Pins 5, 6): Differential Outputs. An impedance transformation may be required to match the outputs. These pins require a DC current path to V_{CC}.

V_{CC} (Pin 7): Power Supply Pin for the Bias Circuits. Typical current consumption is 1.5mA. This pin should be externally bypassed with a 1nF chip capacitor.

Exposed Pad (Pin 9): PGND. Circuit Ground Return for the Entire IC. This must be soldered to the printed circuit board ground plane.

BLOCK DIAGRAM

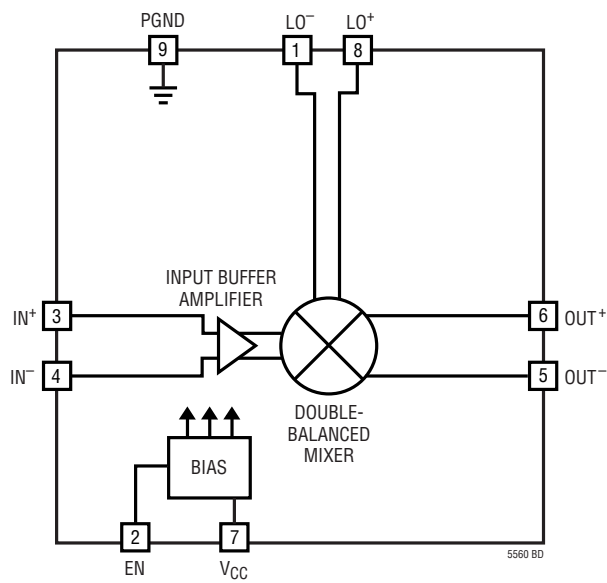

TEST CIRCUITS

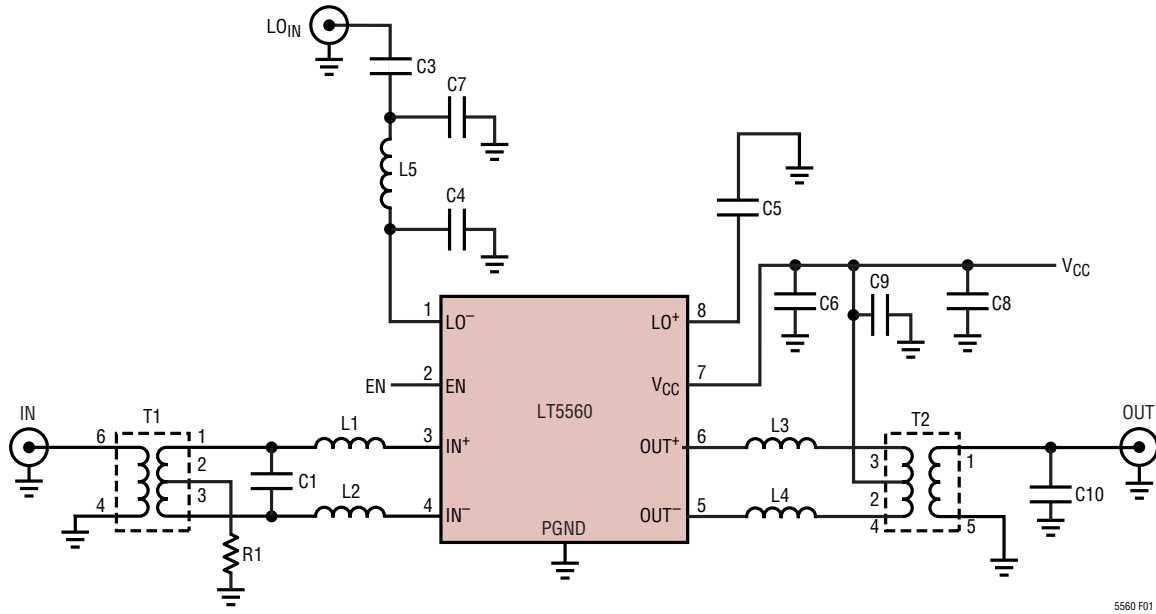

5560 F01

Component Values for $f_{OUT} = 900\text{MHz}$, $f_{IN} = 140\text{MHz}$ and $f_{LO} = 760\text{MHz}$

REF DES	VALUE	SIZE	PART NUMBER	REF DES	VALUE	SIZE	PART NUMBER
C1	22pF	0402	AVX 04025A220JAT	L1, L2	18nH	1005	Toko LL1005-FH18NJ
C3, C5	100pF	0402	AVX 04025A101JAT	L3, L4	27nH	1005	Toko LL1005-FH27NJ
C4	1pF	0402	AVX 04025A1R0BAT	L5	12nH	1005	Toko LL1005-FH12NJ
C6, C9	1nF	0402	AVX 04023C102JAT	R1	3Ω	0402	
C8	1μF	0603	Taiyo Yuden LMK107BJ105MA	T1	1:1		Coilcraft WBC1-1TL
C10	2.2pF	0402	AVX 04025A2R2BAT	T2	4:1		TDK HHM1515B2

Note: C7 not used.

Component Values for $f_{OUT} = 1900\text{MHz}$, $f_{IN} = 140\text{MHz}$ and $f_{LO} = 1760\text{MHz}$

REF DES	VALUE	SIZE	PART NUMBER	REF DES	VALUE	SIZE	PART NUMBER
C1	22pF	0402	AVX 04025A220JAT	L1, L2	18nH	1005	Toko LL1005-FH18NJ
C3	100pF	0402	AVX 04025A101JAT	L3, L4	3.9nH	1005	Toko LL1005-FH3N9S
C7	1.5pF	0402	AVX 04025A1R5BAT	L5	5.6nH	1005	Toko LL1005-FH5N6S
C6, C9	1nF	0402	AVX 04023C102JAT	R1	3Ω	0402	
C8	1μF	0603	Taiyo Yuden LMK107BJ105MA	T1	1:1		Coilcraft WBC1-1TL
C10	1pF	0402	AVX 04025A1R0BAT	T2	1:1		TDK HHM1525

Note: C4 and C5 are not used.

Figure 1. Test Schematic for 900MHz and 1900MHz Upconverting Mixer Applications with 140MHz Input

TEST CIRCUITS

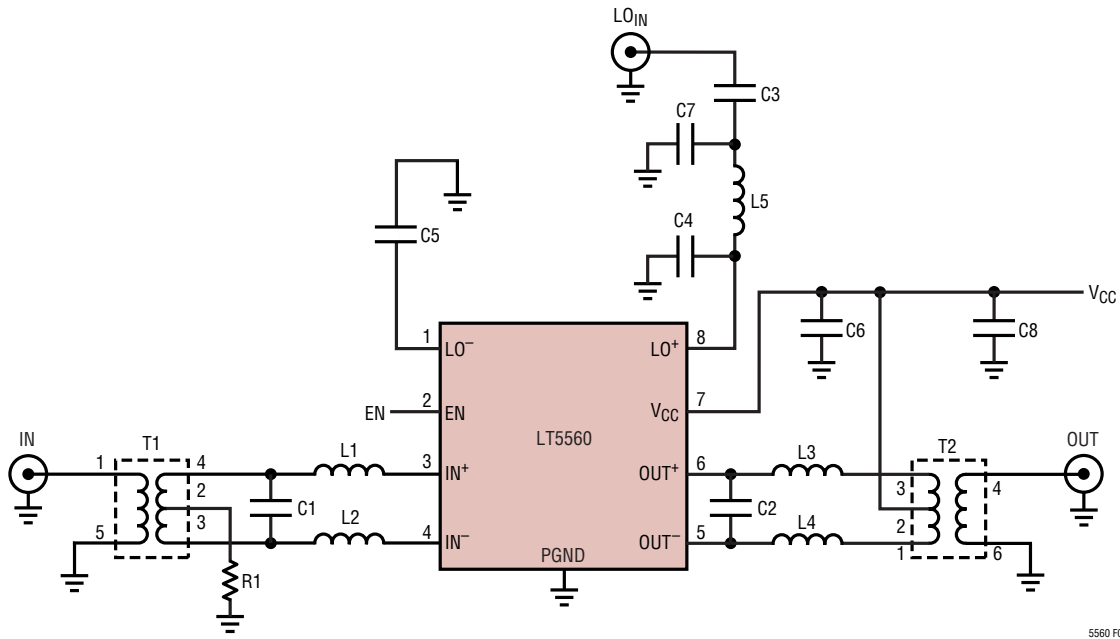

5560 F02

Component Values for $f_{IN} = 900\text{MHz}$, $f_{OUT} = 140\text{MHz}$ and $f_{LO} = 760\text{MHz}$

REF DES	VALUE	SIZE	PART NUMBER	REF DES	VALUE	SIZE	PART NUMBER
C1	2.2pF	0402	AVX 04025A2R2BAT	L1, L2	0Ω	1005	0Ω Resistor
C2	1.2pF	0402	AVX 04025A1R2BAT	L3, L4	220nH	1608	Toko LL1608-FSR22J
C3, C5	100pF	0402	AVX 04025A101JAT	L5	12nH	0402	Toko LL1005-FH12NJ
C4	1pF	0402	AVX 04025A1R0BAT	R1	3Ω	0402	
C6	1nF	0402	AVX 04023C102JAT	T1	1:1		TDK HHM1522B1
C8	1μF	0603	Taiyo Yuden LMK107BJ105MA	T2	4:1		M/A-COM MABAES0061

Note: C7 not used.

Component Values for $f_{IN} = 1900\text{MHz}$, $f_{OUT} = 140\text{MHz}$ and $f_{LO} = 1760\text{MHz}$

REF DES	VALUE	SIZE	PART NUMBER	REF DES	VALUE	SIZE	PART NUMBER
C1	1.0pF	0402	AVX 04025A1R0BAT	L1, L2	0Ω	1005	0Ω Resistor
C2	1.2pF	0402	AVX 04025A1R2BAT	L3, L4	220nH	1608	Toko LL1608-FSR22J
C3	100pF	0402	AVX 04025A101JAT	L5	5.6nH	1005	Toko LL1005-FH5N6S
C7	1.5pF	0402	AVX 04025A1R5BAT	R1	3Ω	0402	
C6	1nF	0402	AVX 04023C102JAT	T1	2:1		TDK HHM1526
C8	1μF	0603	Taiyo Yuden LMK107BJ105MA	T2	4:1		M/A-COM MABAES0061

Note: C4 and C5 are not used.

Figure 2. Test Schematic for 900MHz and 1900MHz Downconverting Mixer Applications with 140MHz Input

TEST CIRCUITS

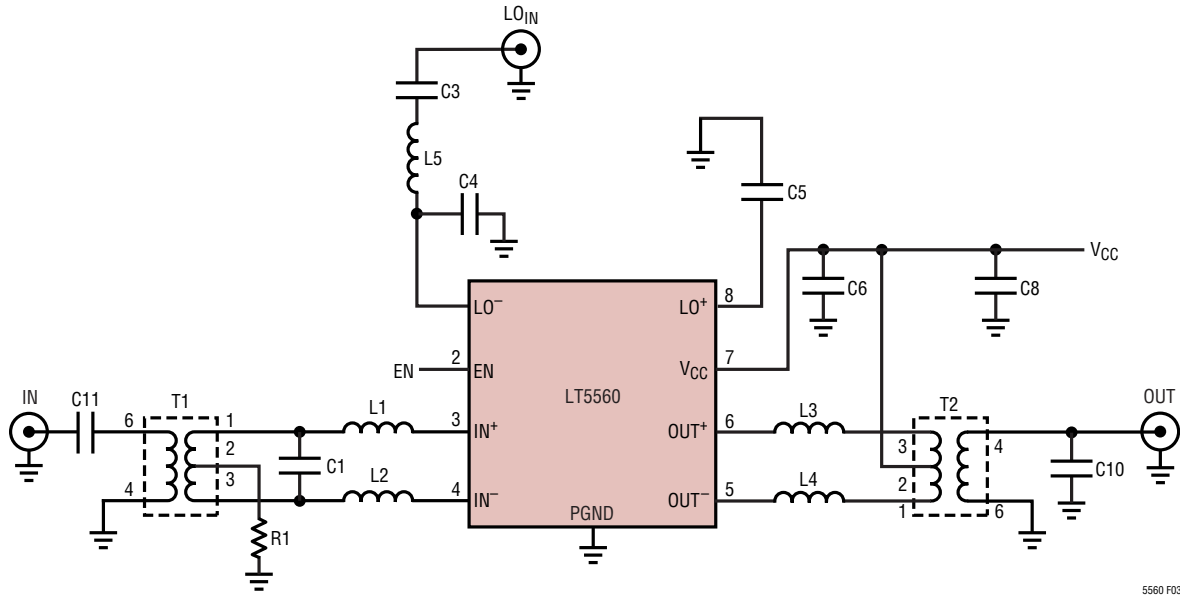

5560 F03

Upconverting Mixer Component Values for $f_{IN} = 70\text{MHz}$, $f_{OUT} = 450\text{MHz}$ and $f_{LO} = 520\text{MHz}$

REF DES	VALUE	SIZE	PART NUMBER	REF DES	VALUE	SIZE	PART NUMBER
C1	39pF	0402	AVX 04025390JAT	L1, L2	33nH	1005	Toko LL1005-FH33NJ
C3, C5, C6	1nF	0402	AVX 04023C102JAT	L3, L4	68nH	1608	Toko LL1608-FS68NJ
C4	1.5pF	0402	AVX 04025A1R5BAT	L5	22nH	1005	Toko LL1005-FH22NJ
C8	1μF	0603	Taiyo Yuden LMK107BJ105MA	R1	3Ω	0402	
C10	1.5pF	0402	AVX 04025A1R5BAT	T1	1:1		Coilcraft WBC1-1TL
				T2	4:1		M/A-COM MABAES0061

Note: C11 is not used.

Downconverting Mixer Component Values for $f_{IN} = 450\text{MHz}$, $f_{OUT} = 70\text{MHz}$ and $f_{LO} = 520\text{MHz}$

REF DES	VALUE	SIZE	PART NUMBER	REF DES	VALUE	SIZE	PART NUMBER
C3, C5, C6	1nF	0402	AVX 04023C102JAT	L3, L4	0Ω	0402	0Ω Resistor
C4	1.5pF	0402	AVX 04025A1R5BAT	L5	22nH	0402	Toko LL1005-FH22NJ
C8	1μF	0603	Taiyo Yuden LMK107BJ105MA	R1	3Ω	0402	
C11	5.6pF	0603	AVX 06035A5R6BAT	T1	1:1		Coilcraft WBC1-1TL
L1, L2	0Ω	0402	0Ω Resistor	T2	16:1		Coilcraft WBC16-1TL

Note: C1 and C10 not used.

Figure 3. Test Schematic for 450MHz Upconverting Mixer and Downconverting Mixer Applications

APPLICATIONS INFORMATION

The LT5560 consists of a double-balanced mixer, a common-base input buffer amplifier, and bias/enable circuits. The IC has been designed for frequency conversion applications up to 4GHz, though operation over a wider frequency range may be possible with reduced performance. For best performance, the input and output should be connected differentially. The LO input can be driven by a single-ended source with either low side or high side LO operation. The LT5560 is characterized and production tested using a single-ended LO drive.

The quiescent DC current of the LT5560 can be adjusted from less than 4mA to approximately 13.5mA through the use of an external resistor. This functionality gives the user the ability to make application dependent trade-offs between IIP3 performance and DC current.

Three demo boards, as described in Table 1, are available depending on the desired application. The listed input and output frequency ranges are based on measured 12dB return loss bandwidths and the LO port frequency ranges are based on 10dB return loss bandwidths. The general circuit topologies are shown in Figures 1, 2 and 3 for DC963B, DC991A and DC1027A, respectively. The board layouts are shown in Figures 23, 24 and 25. The low frequency board, DC1027A, can be reconfigured for upconverting applications.

Table 1. LT5560 Demo Board Descriptions

MIXER DESCRIPTION	DEMO BOARD NUMBER	INPUT FREQ. (MHz)	OUTPUT FREQ. (MHz)	LO FREQ. (MHz)
Upconverting, Cellular Band	DC963B	50-190	850-940	530-930
Downconverting Cellular Band	DC991A	710-1300	110-170	530-930
Downconverting, VHF Band	DC1027A	115-295	3-60	180-310

Note: Consult factory for demo boards for UMTS, WLAN and other bands.

Signal Input Port

Figure 4 shows a simplified schematic of the differential input signal port and an example topology for the external impedance matching circuit. Pins 3 and 4 each source up to 6mA of DC current. This current can be reduced by the addition of resistor R1 (adjustable mixer current is discussed in a later section). The DC ground path can be

provided through the center-tap of an input transformer, as shown, or through matching inductors or chokes connected from pins 3 and 4 to ground.

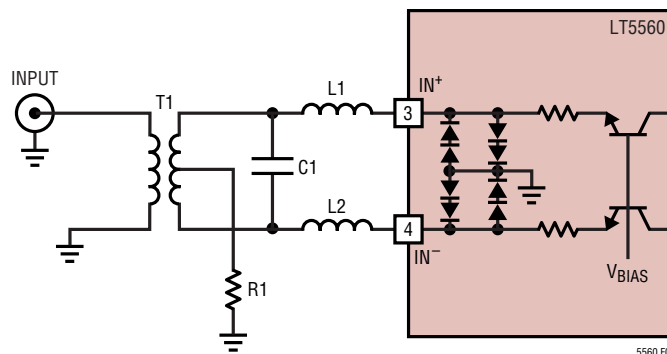

Figure 4. Input Port with Lowpass External Matching Topology

The lowpass impedance matching topology shown may be used to transform the differential input impedance at pins 3 and 4 to match that of the signal source. The differential input impedances for several frequencies are listed in Table 2.

Table 2. Input Signal Port Differential Impedance

FREQUENCY (MHz)	INPUT IMPEDANCE (Ω)	REFLECTION COEFFICIENT ($Z_0 = 50\Omega$)	
		MAG	ANGLE (DEG.)
70	28.5 + j0.8	0.274	177
140	28.5 + j1.6	0.274	174
240	28.6 + j2.7	0.275	171
360	28.6 + j4.0	0.276	167
450	28.6 + j4.9	0.278	163
750	28.8 + j8.2	0.287	153
900	28.8 + j9.8	0.294	148
1500	29.1 + j16.3	0.328	138
1900	29.4 + j20.8	0.357	120
2150	29.6 + j23.6	0.376	114
2450	29.9 + j27.0	0.399	107
3600	31.7 + j42.1	0.499	86.2

APPLICATIONS INFORMATION

The following example demonstrates the design of a lowpass impedance transformation network for a signal input at 900MHz.

The simplified input circuit is shown in Figure 5. For this example, the input transformer has a 1:1 impedance ratio, so $R_S = 50\Omega$. From Table 2, at 900MHz, the differential input impedance is: $R_L + jX_{INT} = 28.8 + j9.8\Omega$. The internal reactance will be used as part of the impedance matching network. The matching circuit consists of additional external series inductance (L1 and L2) and a capacitance (C1) in parallel with the 50Ω source impedance. The external capacitance and inductance are calculated below.

First, calculate the impedance transformation ratio (n) and the network Q:

$$n = \frac{R_S}{R_L} = \frac{50}{28.8} = 1.74$$

$$Q = \sqrt{(n-1)} = 0.858$$

Next, the capacitance and inductance can be calculated as follows:

$$X_C = \frac{R_S}{Q} = 58.3\Omega$$

$$C1 = \frac{1}{\omega \cdot X_C} = 3.03\text{pF}$$

$$X_L = R_L \cdot Q = 24.7\Omega$$

$$X_{EXT} = X_L - X_{INT} = 14.9\Omega$$

$$L1 = L2 = \frac{L_{EXT}}{2} = \frac{X_{EXT}}{2\omega} = 1.32\text{nH}$$

The internal inductance has been accounted for by subtracting the internal reactance (X_{INT}) from the total reactance (X_L). Small inductance values may be realized using high-impedance printed transmission lines instead of lumped inductors. The equations above provide good starting values, though the values may need to be optimized to account for layout and component parasitics.

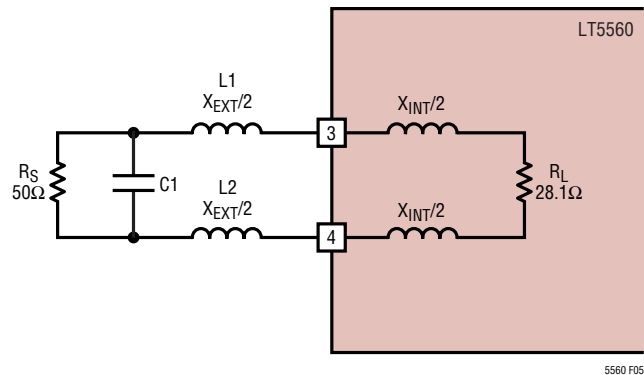

Figure 5. Small Signal Circuit for the Input Port

Table 3 lists actual component values used on the LT5560 evaluation boards for impedance matching at various frequencies. The measured Input Return Loss vs Frequency performance is plotted for several of the cases in Figure 6.

Table 3. Component Values for Input Matching

CASE	FREQ. (MHz)	T1	C1 (pF)	L1, L2 (nH)	MATCH BW (@12dB RL)
1	10	WBC1-1TL 1:1	220	180	6-18
2	70	WBC1-1TL 1:1	39	33	29-102
3	140	WBC1-1TL 1:1	22	18	50-190
4	240	WBC1-1TL 1:1	15	12	115-295
5	450 ¹	WBC1-1TL 1:1	NA	0	390-560
6	900	HHM1522B1 1:1	2.2	0	710-1630
7	1900	HHM1526 2:1	1	0	1660-2500
8	2450	HHM1520A2 2:1	1	0	1640-2580
9	3600	HHM1583B1 2:1	0.5	0	3330-3840

Note 1: Series 5.6pF capacitor is used at the input (see Figure 3).

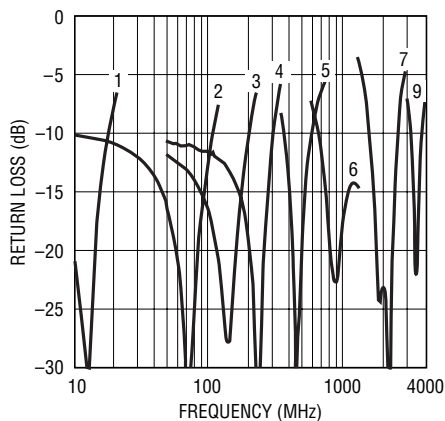

Figure 6. Input Return Loss vs Frequency for Different Matching Values

LO Input Port

Figure 7 shows a simplified schematic of the LO input. The LO input connections drive the bases of the mixer transistors, while a 200Ω resistor across the inputs provides the impedance termination. The internal 1kΩ bias resistors are in parallel with the input resistor resulting in a net input DC resistance of approximately 180Ω. The pins are biased by an internally generated voltage at approximately 1V below V_{CC}; thus external DC blocking capacitors are required. If desired, the LO inputs can be driven differentially. The required LO drive at the IC is 240mV_{RMS} (typ) which can come from a 50Ω source or a higher impedance such as PECL.

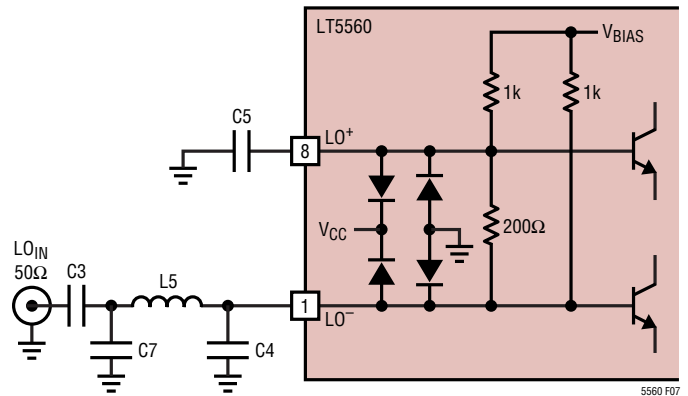

Figure 7. LO Input Schematic

APPLICATIONS INFORMATION

Reactive matching from the LO source to the LO input is recommended to take advantage of the resulting voltage gain. To assist in matching, Table 4 lists the single-ended input impedances of the LO input port. Actual component values, for several LO frequencies, are listed in Table 5. Figure 8 shows the typical return loss response for each case.

Table 4. Single-Ended LO Input Impedance (Parallel Equivalent)

FREQUENCY (MHz)	INPUT IMPEDANCE (Ω)	REFLECTION COEFFICIENT ($Z_0 = 50\Omega$)	
		MAG	ANGLE (DEG.)
150	161 -j679	0.529	-9.3
520	142 -j275	0.494	-23.3
760	130 -j192	0.475	-33.5
1660	74 -j98	0.347	-74.5
1760	69 -j94	0.330	-80.1
2040	60 -j89	0.308	-90.1
2210	51 -j91	0.266	-104
3150	50 -j103	0.235	-104
3340	33 -j41	0.472	-138

Table 5. Component Values for LO Input Matching

CASE	FREQ. (MHz)	C4 (pF)	L5 (nH)	C7 (pF)	C3, C5 (pF)	MATCH BW (@12dB RL)
1	150	8.2	68	-	1000	120-180
2	250	4.7	47	-	1000	195-300
3	520	1.5	22	-	1000	390-605
4	760	1	12	-	100	590-890
5	1200	-	6.8	-	100	850-1430
6	1760	-	4.7	1	100 ¹	1540-1890
7	2900	-	1	1	10	2690-3120
8	3150	-	0	-	10	2990-3480

Note 1: C5 is not used at 1760MHz

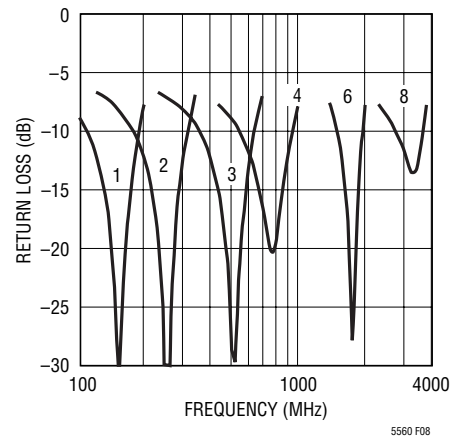

Figure 8. Typical LO Input Return Loss vs Frequency for Different Matching Values

APPLICATIONS INFORMATION

Signal Output Port

A simplified schematic of the output circuit is shown in Figure 9. The output pins, OUT⁺ and OUT⁻, are internally connected to the collectors of the mixer transistors. These pins must be biased at the supply voltage, which can be applied through a transformer center-tap, impedance matching inductors, RF chokes, or pull-up resistors. With external resistor R1 = 3Ω (Figures 1 to 3), each OUT pin draws about 4.5mA of supply current. For optimum performance, these differential outputs should be combined externally through a transformer or balun.

An equivalent small-signal model for the output is shown in Figure 10. The output impedance can be modeled as a 1.2kΩ resistor in parallel with a 0.7pF capacitor. For low frequency applications, the 0.7nH series bond-wire inductances can be ignored.

The external components, C2, L3 and L4, form a lowpass impedance transformation network to match the mixer output impedance to the input impedance of transformer T2. The values for these components can be estimated

using the impedance parameters listed in Table 6 along with similar equations as used for the input matching network. As an example, at an output frequency of 140MHz and R_L = 200Ω (using a 4:1 transformer for T2),

$$n = \frac{R_S}{R_L} = \frac{1082}{200} = 5.41$$

$$Q = \sqrt{(n - 1)} = 2.10$$

$$X_C = \frac{R_S}{Q} = 515\Omega$$

$$C = \frac{1}{\omega \cdot X_C} = 2.21\text{pF}$$

$$C2 = C - C_{INT} = 1.51\text{pF}$$

$$X_L = R_L \cdot Q = 420\Omega$$

$$L3 = L4 = \frac{X_L}{2\omega} = 239\text{nH}$$

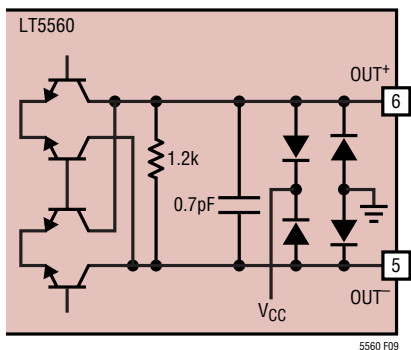

Figure 9. Output Port Schematic

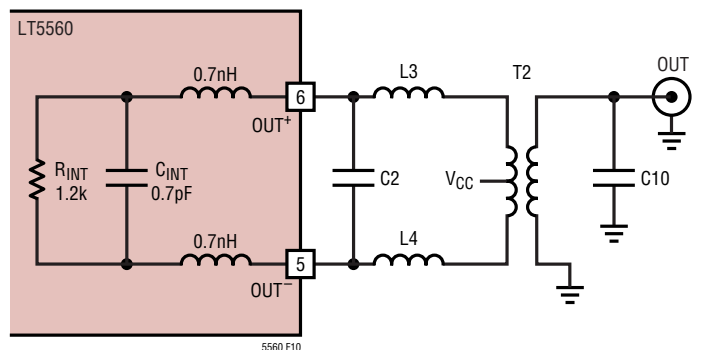

Figure 10. Output Port Small-Signal Model with External Matching

APPLICATIONS INFORMATION

Table 6. Output Port Differential Impedance (Parallel Equivalent)

FREQUENCY (MHz)	OUTPUT IMPEDANCE (Ω)	REFLECTION COEFFICIENT ($Z_0 = 50\Omega$)	
		MAG	ANGLE (DEG.)
70	1098 -j3185	0.913	-1.8
140	1082 -j1600	0.912	-3.6
240	1082 -j974	0.912	-5.9
360	1093 -j646	0.913	-8.9
450	1083 -j522	0.913	-11.0
750	1037 -j320	0.910	-17.8
900	946 -j269	0.903	-21.1
1500	655 -j162	0.870	-34.5
1900	592 -j122	0.865	-44.6
2150	662 -j108	0.883	-50.0
2450	612 -j95.7	0.879	-55.4
3600	188 -j53.1	0.756	-88.7

In cases where the calculated value of C2 is less than the internal output capacitance, capacitor C10 can be used to improve the impedance match.

Table 7 lists actual component values used on the LT5560 evaluation boards for impedance matching at several frequencies. The measured output return loss vs frequency performance is plotted for several of the cases in Figure 11.

Table 7. Component Values for Output Matching

CASE	FREQ. (MHz)	T2	C2 (pF)	L3, L4 (nH)	C10 (pF)	MATCH BW (@12dB RL)
1	10	WBC16-1TL 16:1	-	0	-	3-60
2	70	WBC16-1TL 16:1	-	0	- ¹	3-60
3	140	MABAES0061 4:1	1.5	220	-	110-170
4	240	MABAES0061 4:1	0.5	120	-	175-300
5	380	MABAES0061 4:1	-	68	-	290-490
6	450	MABAES0061 4:1	-	68	1.5	360-540
7	900	HHM1515B2 4:1	-	27	2.2	850-940
8	1900	HHM1525 1:1	-	3.9	1	1820-2000

Note 1: A better 70MHz match can be realized by adding a shunt 180nH inductor at the C10 location.

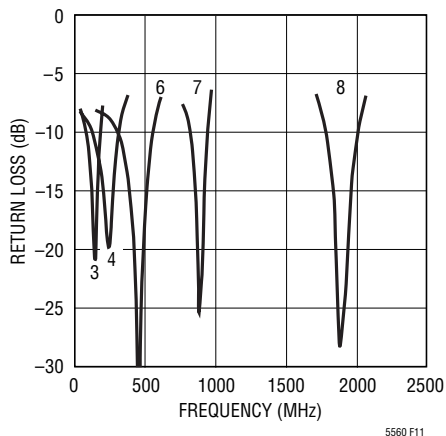

Figure 11. Output Return Loss vs Frequency for Different Matching Values

APPLICATIONS INFORMATION

Enable Interface

Figure 12 shows a simplified schematic of the EN pin interface. The voltage necessary to turn on the LT5560 is 2V. To disable the chip, the enable voltage must be less than 0.3V. If the EN pin is allowed to float, the chip will tend to remain in its last operating state, thus it is not recommended that the enable function be used in this manner. If the shutdown function is not required, then the EN pin should be connected directly to V_{CC} .

The voltage at the EN pin should never exceed the power supply voltage (V_{CC}) by more than 0.3V. If this should occur, the supply current could be sourced through the EN pin ESD diode, potentially damaging the IC.

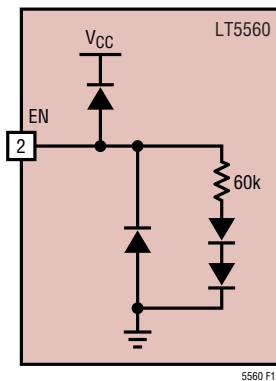

Figure 12. Enable Input Circuit

Adjustable Supply Current

The LT5560 offers a direct trade-off between power supply current and linearity. This capability allows the user to optimize the performance and power dissipation of the mixer for a particular application. The supply current can be adjusted by changing the value of resistor R1 at the center-tap of the input balun. For downconversion applications, a bypass capacitor in parallel with R1 may be desired to minimize noise figure. The bypass capacitor has a greater effect on noise figure at larger values of R1. In upmixer configurations, adding a capacitor across R1 has little effect.

Figure 13 shows the supply current as a function of R1. Note that the current will also be affected by parasitic resistance in the matching components. Figure 14 illustrates the effect of supply current on Gain, IIP3 and NF of a 900MHz upconverting mixer. The performance

vs current of a 900MHz downconverting mixer is plotted in Figure 15. In this example, a 1nF capacitor has been placed in parallel to R1 for best noise figure.

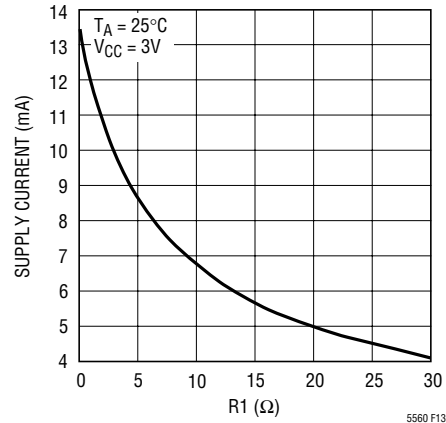

Figure 13. Typical Supply Current vs R1 Value

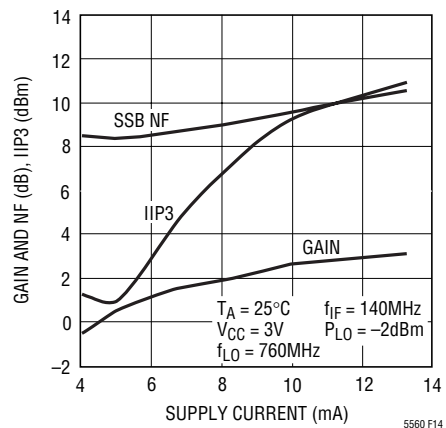

Figure 14. 900MHz Upconverting Mixer Gain, Noise Figure and IIP3 vs Supply Current

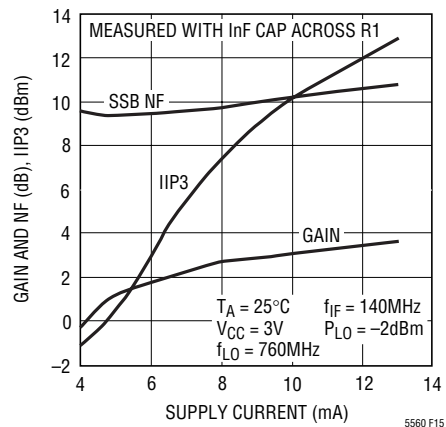

Figure 15. 900MHz Downconverting Mixer Gain, Noise Figure and IIP3 vs Supply Current

APPLICATIONS INFORMATION

Application Examples

The LT5560 may be used as an upconverting or downconverting mixer in a wide variety of applications, in addition to those identified in the datasheet. The following examples illustrate the versatility of the LT5560. (The component values for each case can be found in Tables 3, 5 and 7).

Figure 16 demonstrates gain, IIP3 and IIP2 performance versus RF Output Frequency for the LT5560 when used as a 240MHz upconverting mixer. The input frequency is 10MHz, with an LO frequency of 250MHz. The circuit uses the topology shown in Figure 1.

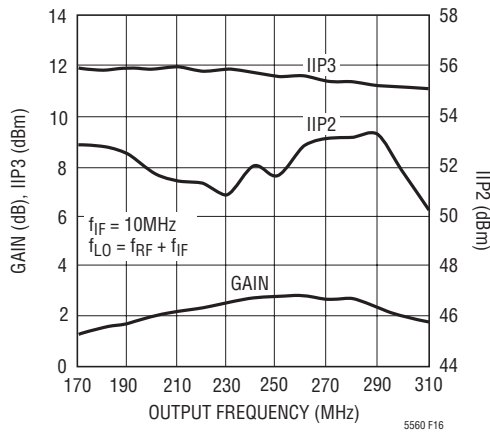

Figure 16. LT5560 Performance in 240MHz Upconverting Mixer Application

The performance in a 140MHz downconverting mixer application is plotted in Figure 17. In this case the gain, IIP3 and NF are shown as a function of LO power with an IF output frequency of 10MHz. The circuit topology for this case is shown in Figure 3.

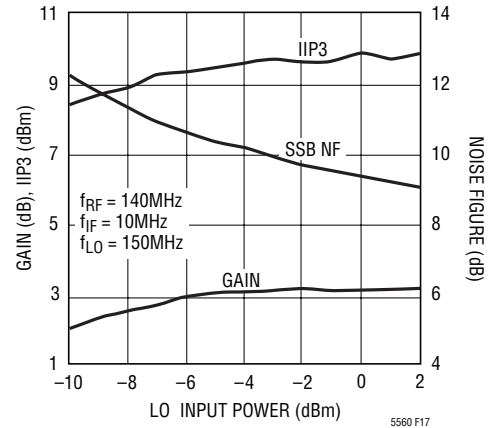

Figure 17. LT5560 Performance in 140MHz Downconverting Mixer Application

The LT5560 operation at higher frequencies is demonstrated in Figure 18, where the performance of a 3600MHz downconverting mixer is shown. The conversion gain, IIP3 and DSB NF are plotted for an RF input frequency range of 3300 to 3800MHz and an IF frequency of 450MHz. The circuit is the same topology as shown in Figure 2.

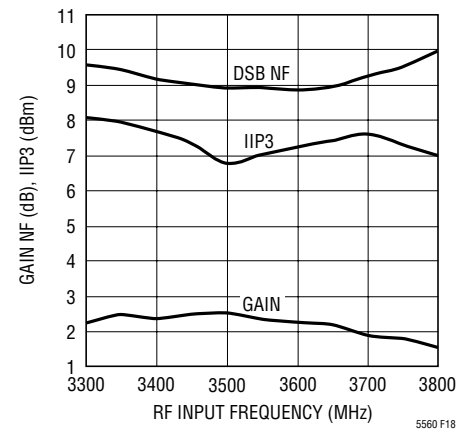

Figure 18. LT5560 Performance as a 3600MHz Downconverting Mixer

APPLICATIONS INFORMATION

Lumped Element Matching

The applications described so far have employed external transformers or hybrid baluns to realize single-ended to differential conversions and, in some cases, impedance transformations. An alternate approach is to use lumped-element baluns to realize the input or output matching networks.

A lumped element balun topology is shown in Figure 19. The desired component values can be estimated using the equations below, where R_A and R_B are the terminating resistances on the unbalanced and balanced ports, respectively. Variable f_C is the desired center frequency. (The resistances of the LT5560 input and output can be found in Tables 2 and 6).

$$L_0 = \frac{\sqrt{R_A \cdot R_B}}{2 \cdot \pi \cdot f_C}$$

$$C_0 = \frac{1}{2 \cdot \pi \cdot f_C \cdot \sqrt{R_A \cdot R_B}}$$

The computed values are approximate, as they don't account for the effects of parasitics of the IC and external components.

Inductor L_{DC} is used to provide a DC path to ground or V_{CC} depending on whether the circuit is used at the input or output of the LT5560. In some cases, it is desirable to make the value of L_{DC} as large as practical to minimize loading on the circuit; however, the value can also be optimized to tune the impedance match. The shunt inductor, L_0 , provides the DC path for the other balanced port.

Capacitor C_{DC} may be required for DC blocking but can often be omitted if DC decoupling is not required.

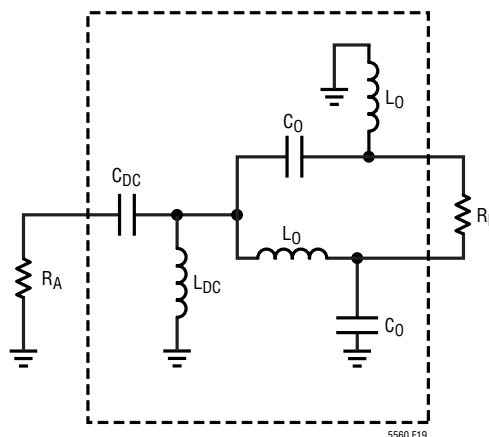

Figure 19. Lumped Element Balun

In some applications, C_{DC} is useful for optimizing the impedance match.

The circuit shown on page 1 illustrates the use of lumped element baluns. In this example, the LT5560 is used to convert a 900MHz input signal down to 140MHz using a 760MHz L_0 signal.

For the 900MHz input, $R_A = 50\Omega$ and $R_B = 28\Omega$ (from Table 2). The actual values used for C_0 and L_0 are 4.7pF and 6.8nH, which agree very closely with the calculated values of 4.7pF and 6.6nH. The 15nH shunt inductor, in this case, has been used to optimize the impedance match, while the 100pF cap provides DC decoupling.

At the 140MHz output, the values used for R_A and R_B are 50 Ω and 1080 Ω (from Table 6), respectively, which result in calculated values of $C_0 = 4.9\text{pF}$ and $L_0 = 265\text{nH}$. These values are very close to the actual values of 4.7pF and 270nH. A shunt inductor (L_{DC}) of 270nH is used here and the 33pF blocking cap has been used to optimize the impedance.

APPLICATIONS INFORMATION

Measured IF_{OUT} and IM3 levels vs RF input power for the mixer with lumped element baluns are shown on page 1. Additional performance parameters vs RF input frequency are plotted in Figure 20.

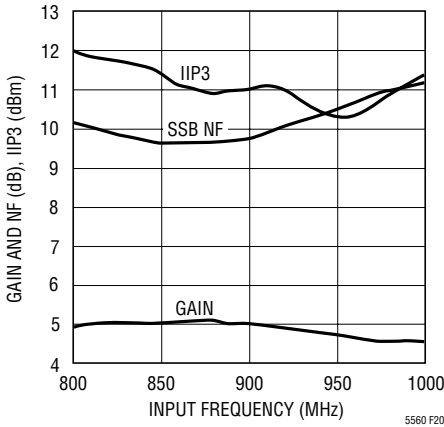

Figure 20. Performance of 900MHz Downconverting Mixer with Lumped Element Baluns

Low Frequency Applications

At low IF frequencies, where transformers can be impractical due to their large size and cost, alternate methods can be used to achieve desired differential to single-ended conversions. The examples in Figures 21 and 22 use an

op-amp to demonstrate performance with an output frequency of 450KHz. Pull-up resistors R3 and R4 are used at the open-collector IF outputs instead of large inductors. The op-amp provides gain and converts the mixer differential outputs to single-ended. At low frequencies, the LO port can be easily matched with a shunt resistor and a DC blocking cap. This IF interface circuit can be used for signals up to 1MHz.

Figure 21 shows an input match that uses a transformer to present a differential signal to the mixer. A possible alternative, shown in Figure 22, is to use a single-ended drive on one input pin, with the other pin grounded. This approach is more cost effective than the transformer, however, some performance is sacrificed. Another option is to use a lumped-element balun, which requires only one more component than the single-ended impedance match, but could provide better performance. Measured data for the examples below are summarized in Table 8.

Table 8. Low-Frequency Performance

f_{IN} (MHz)	f_{OUT} (MHz)	G_C (dB)	IIP3 (dBm)	DSB NF (dB)	I_{CC} (mA)
200	0.45	9	3.8	11.6	14
90	0.45	6.8	3.3	22	18

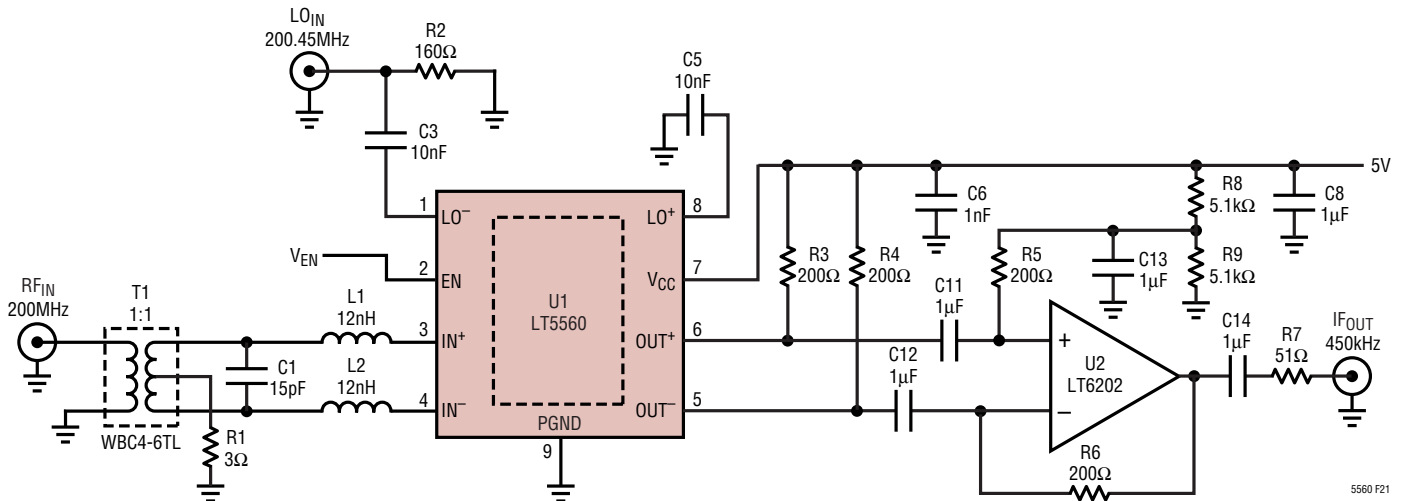

Figure 21. A 200MHz to 450KHz Downconverter with Active IF Interface

APPLICATIONS INFORMATION

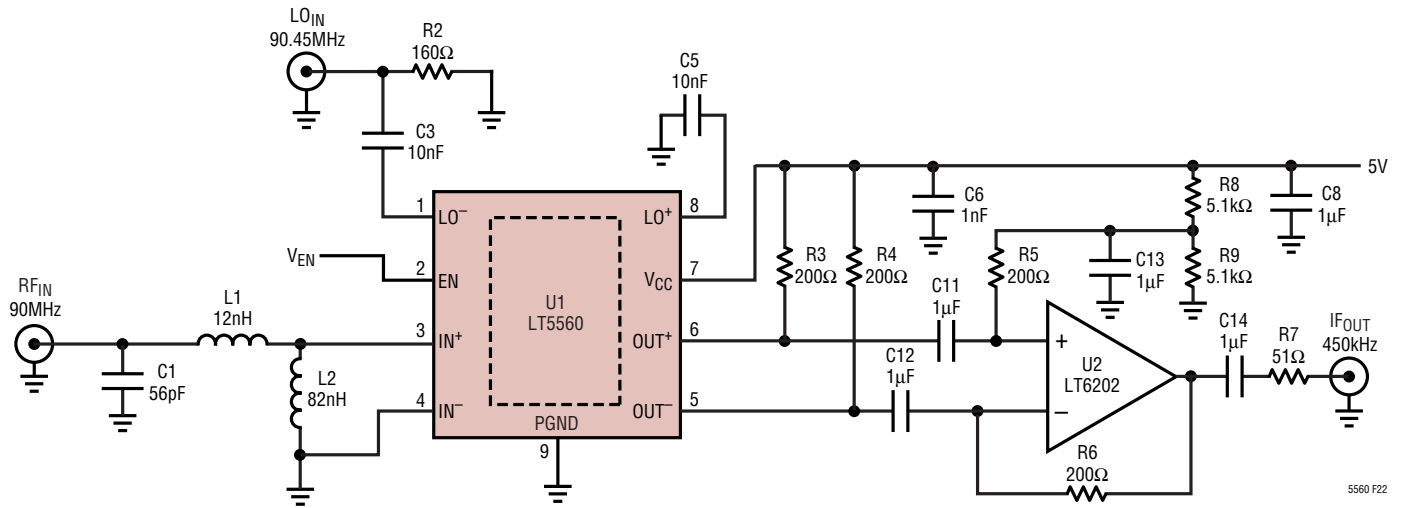

Figure 22. 90MHz Downconverter with a Low Cost Discrete Balun Input and a 450kHz Active IF Interface

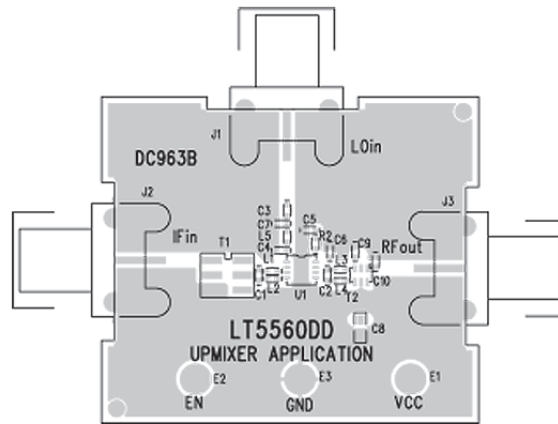

Figure 23. Upconverting Mixer Evaluation Board (DC963B)—See Table 1

TYPICAL APPLICATIONS

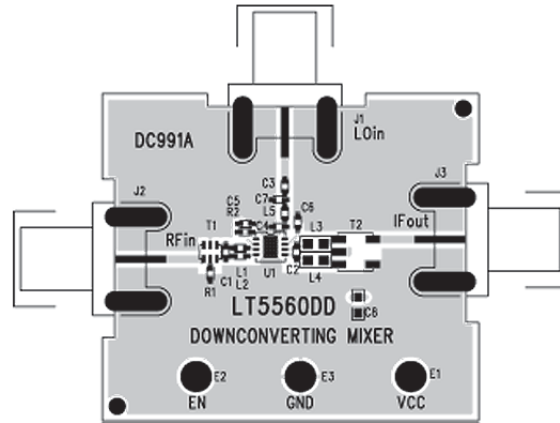

Figure 24. Downconverting Mixer Evaluation Board (DC991A)—See Table 1

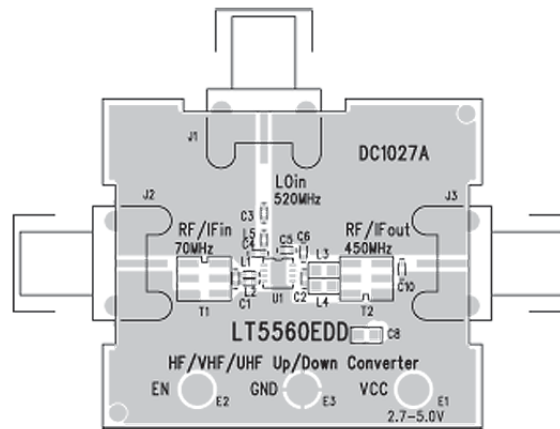
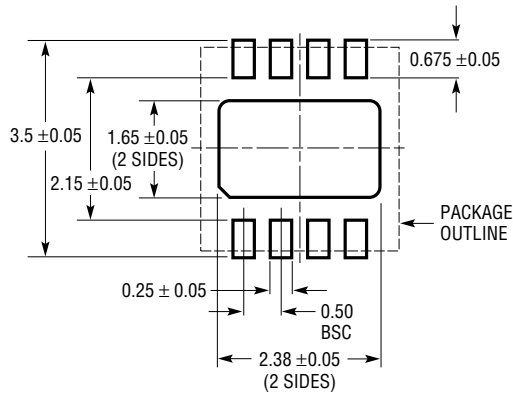

Figure 25. HF/VHF/UHF Upconverting or Downconverting Mixer Evaluation Board (DC1027A)—See Table 1

PACKAGE DESCRIPTION

DD8 Package 8-Lead Plastic DFN (3mm × 3mm) (Reference LTC DWG # 05-08-1698)



RECOMMENDED SOLDER PAD PITCH AND DIMENSIONS

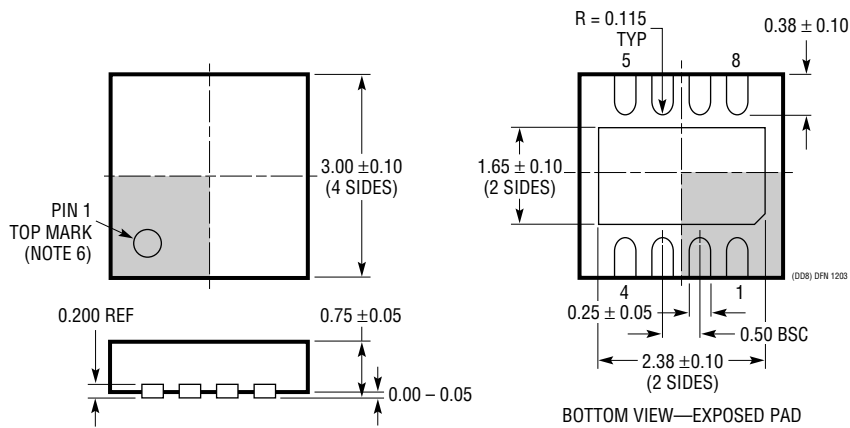

- NOTE:
1. DRAWING TO BE MADE A JEDEC PACKAGE OUTLINE M0-229 VARIATION OF (WEED-1)
 2. DRAWING NOT TO SCALE
 3. ALL DIMENSIONS ARE IN MILLIMETERS
 4. DIMENSIONS OF EXPOSED PAD ON BOTTOM OF PACKAGE DO NOT INCLUDE MOLD FLASH. MOLD FLASH, IF PRESENT, SHALL NOT EXCEED 0.15mm ON ANY SIDE
 5. EXPOSED PAD SHALL BE SOLDER PLATED
 6. SHADED AREA IS ONLY A REFERENCE FOR PIN 1 LOCATION ON TOP AND BOTTOM OF PACKAGE

RELATED PARTS

PART NUMBER	DESCRIPTION	COMMENTS
Infrastructure		
LT5511	High Linearity Upconverting Mixer	RF Output to 3GHz, 17dBm IIP3, Integrated LO Buffer
LT5512	1KHz to 3GHz High Signal Level Downconverting Mixer	20dBm IIP3, Integrated LO Buffer, HF/VHF/UHF Optimized
LT5514	Ultralow Distortion, IF Amplifier/ADC Driver with Digitally Controlled Gain	850MHz Bandwidth, 47dBm OIP3 at 100MHz, 10.5dB to 33dB Gain Control Range
LT5515	1.5GHz to 2.5GHz Direct Conversion Quadrature Demodulator	20dBm IIP3, Integrated LO Quadrature Generator
LT5516	0.8GHz to 1.5GHz Direct Conversion Quadrature Demodulator	21.5dBm IIP3, Integrated LO Quadrature Generator
LT5517	40MHz to 900MHz Quadrature Demodulator	21dBm IIP3, Integrated LO Quadrature Generator
LT5518	1.5GHz to 2.4GHz High Linearity Direct Quadrature Modulator	22.8dBm OIP3 at 2GHz, -158.2dBm/Hz Noise Floor, 50Ω Single-Ended LO and RF Ports, 4-Ch W-CDMA ACPR = -64dBc at 2.14GHz
LT5519	0.7GHz to 1.4GHz High Linearity Upconverting Mixer	17.1dBm IIP3 at 1GHz, Integrated RF Output Transformer with 50Ω Matching, Single-Ended LO and RF Ports Operation
LT5520	1.3GHz to 2.3GHz High Linearity Upconverting Mixer	15.9dBm IIP3 at 1.9GHz, Integrated RF Output Transformer with 50Ω Matching, Single-Ended LO and RF Ports Operation
LT5521	10MHz to 3700MHz High Linearity Upconverting Mixer	24.2dBm IIP3 at 1.95GHz, NF = 12.5dB, 3.15V to 5.25V Supply, Single-Ended LO Port Operation
LT5522	400MHz to 2.7GHz High Signal Level Downconverting Mixer	4.5V to 5.25V Supply, 25dBm IIP3 at 900MHz, NF = 12.5dB, 50Ω Single-Ended RF and LO Ports
LT5524	Low Power, Low Distortion ADC Driver with Digitally Programmable Gain	450MHz Bandwidth, 40dBm OIP3, 4.5dB to 27dB Gain Control
LT5525	High Linearity, Low Power Downconverting Mixer	50Ω Single-Ended LO and RF Ports, 17.6 dBm IIP3 at 1900MHz, I _{CC} = 28mA
LT5526	High Linearity, Low Power Active Mixer	3V to 5.3V Supply, 16.5dBm IIP3, 100kHz to 2GHz RF, NF = 11dB, I _{CC} = 28mA, -65dBm LO-RF Leakage
LT5527	400MHz to 3.7GHz High Signal Level Downconverting Mixer	IIP3 = 23.5dBm and NF = 12.5dB at 1900MHz, 4.5V to 5.25V Supply, I _{CC} = 78mA, Single-Ended LO and RF Ports
LT5528	1.5GHz to 2.4GHz High Linearity Direct Quadrature Modulator	21.8dBm OIP3 at 2GHz, -159.3dBm/Hz Noise Floor, 50Ω, 0.5V _{DC} Baseband Interface, 4-Ch W-CDMA ACPR = -66dBc at 2.14GHz
LT5568	700MHz to 1050MHz High Linearity Direct Quadrature Modulator	22.9dBm OIP3, -160dBm/Hz Noise Floor, -46dBc Image Rejection, -43dBm LO Leakage
RF Power Detectors		
LTC®5505	RF Power Detectors with >40dB Dynamic Range	300MHz to 3GHz, Temperature Compensated, 2.7V to 6V Supply
LTC5507	100kHz to 1000MHz RF Power Detector	100kHz to 1GHz, Temperature Compensated, 2.7V to 6V Supply
LTC5508	300MHz to 7GHz RF Power Detector	44dB Dynamic Range, Temperature Compensated, SC70 Package
LTC5509	300MHz to 3GHz RF Power Detector	36dB Linear Dynamic Range, Low Power Consumption, SC70 Package
LTC5532	300MHz to 7GHz Precision RF Power Detector	Precision V _{OUT} Offset Control, Adjustable Gain and Offset
LT5534	50MHz to 3GHz Log RF Power Detector with 60dB Dynamic Range	±1dB Output Variation over Temperature, 38ns Response Time
LTC5536	Precision 600MHz to 7GHz RF Detector with Fast Comparater	25ns Response Time, Comparator Reference Input, Latch Enable Input, -26dBm to +12dBm Input Range
LT5537	Wide Dynamic Range Log RF/IF Detector	Low Frequency to 800MHz, 83dB Dynamic Range, 2.7V to 5.25V Supply

Компания «Океан Электроники» предлагает заключение долгосрочных отношений при поставках импортных электронных компонентов на взаимовыгодных условиях!

Наши преимущества:

- Поставка оригинальных импортных электронных компонентов напрямую с производств Америки, Европы и Азии, а так же с крупнейших складов мира;
- Широкая линейка поставок активных и пассивных импортных электронных компонентов (более 30 млн. наименований);
- Поставка сложных, дефицитных, либо снятых с производства позиций;
- Оперативные сроки поставки под заказ (от 5 рабочих дней);
- Экспресс доставка в любую точку России;
- Помощь Конструкторского Отдела и консультации квалифицированных инженеров;
- Техническая поддержка проекта, помощь в подборе аналогов, поставка прототипов;
- Поставка электронных компонентов под контролем ВП;
- Система менеджмента качества сертифицирована по Международному стандарту ISO 9001;
- При необходимости вся продукция военного и аэрокосмического назначения проходит испытания и сертификацию в лаборатории (по согласованию с заказчиком);
- Поставка специализированных компонентов военного и аэрокосмического уровня качества (Xilinx, Altera, Analog Devices, Intersil, Interpoint, Microsemi, Actel, Aeroflex, Peregrine, VPT, Syfer, Eurofarad, Texas Instruments, MS Kennedy, Miteq, Cobham, E2V, MA-COM, Hittite, Mini-Circuits, General Dynamics и др.);

Компания «Океан Электроники» является официальным дистрибьютором и эксклюзивным представителем в России одного из крупнейших производителей разъемов военного и аэрокосмического назначения «JONHON», а так же официальным дистрибьютором и эксклюзивным представителем в России производителя высокотехнологичных и надежных решений для передачи СВЧ сигналов «FORSTAR».



JONHON

«JONHON» (основан в 1970 г.)

Разъемы специального, военного и аэрокосмического назначения:

(Применяются в военной, авиационной, аэрокосмической, морской, железнодорожной, горно- и нефтедобывающей отраслях промышленности)

«FORSTAR» (основан в 1998 г.)

ВЧ соединители, коаксиальные кабели, кабельные сборки и микроволновые компоненты:

(Применяются в телекоммуникациях гражданского и специального назначения, в средствах связи, РЛС, а так же военной, авиационной и аэрокосмической отраслях промышленности).



Телефон: 8 (812) 309-75-97 (многоканальный)

Факс: 8 (812) 320-03-32

Электронная почта: ocean@oceanchips.ru

Web: <http://oceanchips.ru/>

Адрес: 198099, г. Санкт-Петербург, ул. Калинина, д. 2, корп. 4, лит. А