

Programmable Timing Control Hub™ for Next Gen P4™ processor

Recommended Application:

VIA VX/CX 700 style chipset for P4 processor

Output Features:

- 3 - 0.7V current-mode differential CPU pairs
- 10 - PCI, 3 free running, 33MHz
- 2 - REF, 14.318MHz
- 3 - 3V66, 66.66MHz
- 1 - 48MHz
- 1 - 24/48MHz
- 2 - 25MHz, 2 free running @2.5V or 3.3V

Functionality

| Bit4 | Bit3 | Bit2 | Bit1 | Bit0 | CPU | AGP | PCI |
|------|------|------|------|------|--------|-------|-------|
| FS4 | FS3 | FS2 | FS1 | FS0 | MHz | MHz | MHz |
| 0 | 0 | 0 | 0 | 0 | 100.00 | 66.67 | 33.33 |
| 0 | 0 | 0 | 0 | 1 | 200.00 | 66.67 | 33.33 |
| 0 | 0 | 0 | 1 | 0 | 133.33 | 66.67 | 33.33 |
| 0 | 0 | 0 | 1 | 1 | 166.67 | 66.67 | 33.33 |
| 0 | 0 | 1 | 0 | 0 | 200.00 | 66.67 | 33.33 |
| 0 | 0 | 1 | 0 | 1 | 400.00 | 66.67 | 33.33 |
| 0 | 0 | 1 | 1 | 0 | 266.67 | 66.67 | 33.33 |
| 0 | 0 | 1 | 1 | 1 | 333.33 | 66.67 | 33.33 |
| 0 | 1 | 0 | 0 | 0 | 100.99 | 67.33 | 33.66 |
| 0 | 1 | 0 | 0 | 1 | 201.98 | 67.33 | 33.66 |
| 0 | 1 | 0 | 1 | 0 | 134.65 | 67.33 | 33.66 |
| 0 | 1 | 0 | 1 | 1 | 168.31 | 67.32 | 33.66 |
| 0 | 1 | 1 | 0 | 0 | 115.00 | 76.67 | 38.33 |
| 0 | 1 | 1 | 0 | 1 | 230.00 | 76.67 | 38.33 |
| 0 | 1 | 1 | 1 | 0 | 153.33 | 76.66 | 38.33 |
| 0 | 1 | 1 | 1 | 1 | 191.67 | 76.67 | 38.33 |
| 1 | 0 | 0 | 0 | 0 | 100.00 | 66.66 | 33.33 |
| 1 | 0 | 0 | 0 | 1 | 200.00 | 66.66 | 33.33 |
| 1 | 0 | 0 | 1 | 0 | 133.33 | 66.66 | 33.33 |
| 1 | 0 | 0 | 1 | 1 | 166.67 | 71.43 | 35.71 |
| 1 | 0 | 1 | 0 | 0 | 200.00 | 66.66 | 33.33 |
| 1 | 0 | 1 | 0 | 1 | 400.00 | 66.66 | 33.33 |
| 1 | 0 | 1 | 1 | 0 | 266.67 | 66.66 | 33.33 |
| 1 | 0 | 1 | 1 | 1 | 333.33 | 66.66 | 33.33 |
| 1 | 1 | 0 | 0 | 0 | 105.00 | 69.99 | 35.00 |
| 1 | 1 | 0 | 0 | 1 | 210.00 | 69.99 | 35.00 |
| 1 | 1 | 0 | 1 | 0 | 140.00 | 69.99 | 35.00 |
| 1 | 1 | 0 | 1 | 1 | 175.00 | 69.99 | 35.00 |
| 1 | 1 | 1 | 0 | 0 | 110.00 | 73.33 | 36.66 |
| 1 | 1 | 1 | 0 | 1 | 220.00 | 73.33 | 36.66 |
| 1 | 1 | 1 | 1 | 0 | 146.66 | 73.33 | 36.66 |
| 1 | 1 | 1 | 1 | 1 | 183.34 | 73.33 | 36.66 |

Key Specifications:

- CPU-CPU +/-250ps
- CPU/SRC outputs cycle-cycle jitter < 125ps
- 3V66 outputs cycle-cycle jitter < 250ps
- PCI outputs cycle-cycle jitter < 250ps
- AGP leads CPU between .75 to -3ns
- CPU-PCI skew between 1.6 to -1.5ns

Features/Benefits:

- Programmable output frequency.
- Programmable asynchronous 3V66&PCI frequency.
- Programmable output divider ratios.
- Programmable output skew.
- Programmable spread percentage for EMI control.
- Watchdog timer technology to reset system if system malfunctions.
- Programmable watch dog safe frequency.
- Support I2C Index read/write and block read/write operations.
- Uses external 14.318MHz reference input.

Pin Configuration

| | | | |
|----------------------|----|----|-------------------------|
| *FS1/REF0 | 1 | 48 | VDDA |
| **FS0/REF1 | 2 | 47 | GND |
| VDDREF | 3 | 46 | IREF |
| X1 | 4 | 45 | CPUCLKT_ITP/(PCI_STOP#) |
| X2 | 5 | 44 | CPUCLKC_ITP/(CPU_STOP#) |
| GND | 6 | 43 | GND |
| **FS2/PCICLK_F0 | 7 | 42 | CPUCLKT1 |
| **FS4/PCICLK_F1 | 8 | 41 | CPUCLKC1 |
| PCICLK_F2 | 9 | 40 | VDDCPU |
| VDDPCI | 10 | 39 | CPUCLKT0 |
| GND | 11 | 38 | CPUCLKC0 |
| **MODE/PCICLK0 | 12 | 37 | GND |
| PCICLK1 | 13 | 36 | 25Mhz_0F |
| PCICLK2 | 14 | 35 | 25Mhz_1F |
| PCICLK3 | 15 | 34 | VDD25M |
| PCICLK4 | 16 | 33 | VttPWR_GD/PD#/WOL_STOP# |
| VDDPCI | 17 | 32 | SDATA |
| GND | 18 | 31 | SCLK |
| PCICLK5 | 19 | 30 | Reset# |
| PCICLK6 | 20 | 29 | 3V66_0 |
| **FS3/48MHz | 21 | 28 | GND |
| **Sel24_48#/24_48MHz | 22 | 27 | VDD3V66 |
| GND | 23 | 26 | 3V66_1 |
| VDD48 | 24 | 25 | 3V66_2 |

* This pin have 120K pull-up to VDD

** This pin have 120K pull-down to GND

48-pin SSOP & TSSOP

Pin Description

| Pin # | PIN NAME | PIN TYPE | DESCRIPTION |
|-------|-------------------------|----------|--|
| 1 | *FS1/REF0 | I/O | Frequency select latch input pin / 14.318 MHz reference clock. |
| 2 | **FS0/REF1 | I/O | Frequency select latch input pin / 14.318 MHz reference clock. |
| 3 | VDDREF | PWR | Ref, XTAL power supply, nominal 3.3V |
| 4 | X1 | IN | Crystal input, Nominally 14.318MHz. |
| 5 | X2 | OUT | Crystal output, Nominally 14.318MHz |
| 6 | GND | PWR | Ground pin. |
| 7 | **FS2/PCICLK_F0 | I/O | Frequency select latch input pin / 3.3V PCI free running clock output. |
| 8 | **FS4/PCICLK_F1 | I/O | Frequency select latch input pin / 3.3V PCI free running clock output. |
| 9 | PCICLK_F2 | OUT | Free running PCI clock not affected by PCI_STOP# . |
| 10 | VDDPCI | PWR | Power supply for PCI clocks, nominal 3.3V |
| 11 | GND | PWR | Ground pin. |
| 12 | **MODE/PCICLK0 | I/O | Function select latch input pin, 0=Desktop Mode (pin 44/45 are outputs), 1=Mobile Mode (pin44/45 are STOP inputs) / PCI clock output. |
| 13 | PCICLK1 | OUT | PCI clock output. |
| 14 | PCICLK2 | OUT | PCI clock output. |
| 15 | PCICLK3 | OUT | PCI clock output. |
| 16 | PCICLK4 | OUT | PCI clock output. |
| 17 | VDDPCI | PWR | Power supply for PCI clocks, nominal 3.3V |
| 18 | GND | PWR | Ground pin. |
| 19 | PCICLK5 | OUT | PCI clock output. |
| 20 | PCICLK6 | OUT | PCI clock output. |
| 21 | **FS3/48MHz | I/O | Frequency select latch input pin / Fixed 48MHz clock output. 3.3V |
| 22 | **Sel24_48#/24_48MHz | I/O | Latched select input for 24/48MHz output / 24/48MHz clock output. 1=24MHz, 0 = 48MHz. |
| 23 | GND | PWR | Ground pin. |
| 24 | VDD48 | PWR | Power pin for the 48MHz output.3.3V |
| 25 | 3V66_2 | OUT | 3.3V 66.66MHz clock output |
| 26 | 3V66_1 | OUT | 3.3V 66.66MHz clock output |
| 27 | VDD3V66 | PWR | Power pin for the 3.3V 66MHz clocks. |
| 28 | GND | PWR | Ground pin. |
| 29 | 3V66_0 | OUT | 3.3V 66.66MHz clock output |
| 30 | Reset# | OUT | Real time system reset signal for frequency gear ratio change or watchdog timer timeout. This signal is active low |
| 31 | SCLK | IN | Clock pin of SMBus circuitry, 5V tolerant. |
| 32 | SDATA | I/O | Data pin for SMBus circuitry, 5V tolerant. |
| 33 | VttPWR_GD/PD#/WOL_STOP# | IN | Active high 3.3V LVTTTL input, level sensitive strobe used to determine when latch inputs are valid to sample /Asynchronous active low input pin used to power down the device into a low power state. / Asynchronous active low input pin that stops all outputs except free running 25Mhz. |
| 34 | VDD25M | PWR | Power supply, nominal 2.5V or 3.3V |
| 35 | 25Mhz_1F | OUT | Free running 25MHz clock output, 2.5V or 3.3V (not affected by WOL_STOP#). Default set to stoppable. |
| 36 | 25Mhz_0F | OUT | Default free running 25MHz clock output, 2.5V or 3.3V (not affected by WOL_STOP#). Default set to Free-running. |
| 37 | GND | PWR | Ground pin. |
| 38 | CPUCLKC0 | OUT | Complementary clock of differential pair CPU outputs. These are current mode outputs. External resistors are required for voltage bias. |
| 39 | CPUCLKT0 | OUT | True clock of differential pair CPU outputs. These are current mode outputs. External resistors are required for voltage bias. |
| 40 | VDDCPU | PWR | Supply for CPU clocks, 3.3V nominal |
| 41 | CPUCLKC1 | OUT | Complementary clock of differential pair CPU outputs. These are current mode outputs. External resistors are required for voltage bias. |
| 42 | CPUCLKT1 | OUT | True clock of differential pair CPU outputs. These are current mode outputs. External resistors are required for voltage bias. |
| 43 | GND | PWR | Ground pin. |
| 44 | CPUCLKC_ITP/(CPU_STOP#) | I/O | Complementary clock of differential pair CPU outputs. These are current mode outputs. External resistors are required for voltage bias. / Stops all CPUCLK besides the free running clocks |
| 45 | CPUCLKT_ITP/(PCI_STOP#) | I/O | True clock of differential pair CPU outputs. These are current mode outputs. External resistors are required for voltage bias. / Stops all PCICLK besides the free running clocks |
| 46 | IREF | OUT | This pin establishes the reference current for the differential current-mode output pairs. This pin requires a fixed precision resistor tied to ground in order to establish the appropriate current. 475 ohms is the standard value |
| 47 | GND | PWR | Ground pin. |
| 48 | VDDA | PWR | 3.3V power for the PLL core. |

General Description

ICS952926 is a 48 pin clock chip for VIA VX/CX 700 style chipsets. When used with a fanout DDR buffer, such as the 93788, it provides all the necessary clock signals for such a system.

The **ICS952926** is part of a whole new line of ICS clock generators and buffers called TCH™ (Timing Control Hub). This part incorporates ICS's newest clock technology which offers more robust features and functionality. Employing the use of a serially programmable I²C interface, this device can adjust the output clocks by configuring the frequency setting, the output divider ratios, selecting the ideal spread percentage, the output skew, the output strength, and enabling/disabling each individual output clock. M/N control can configure output frequency with resolution up to 0.1MHz increment.

Block Diagram

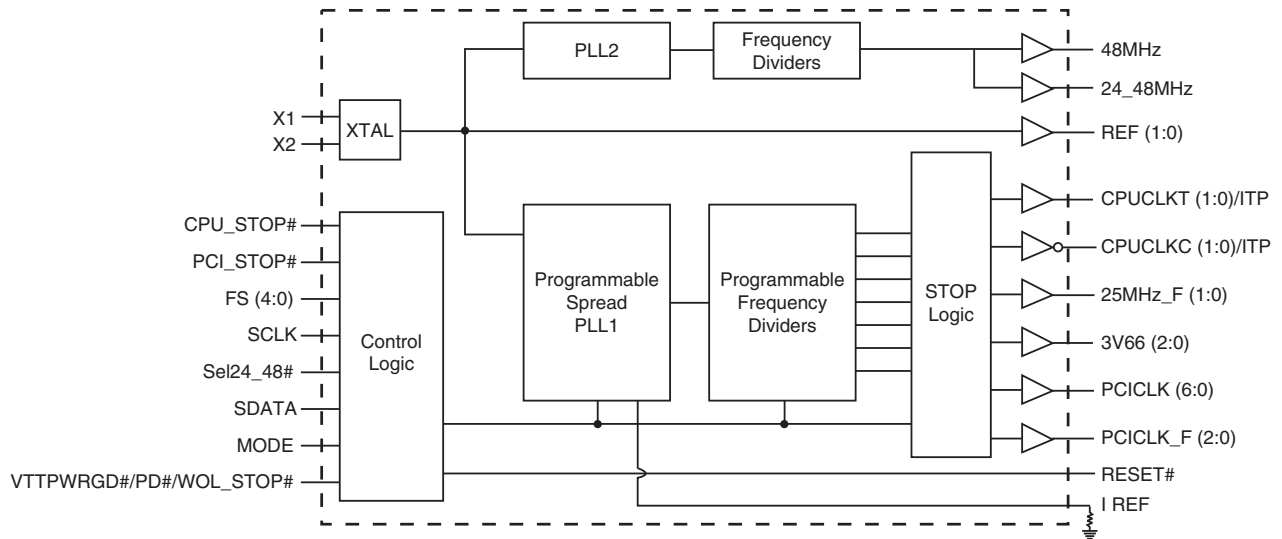

Power Groups

| Pin Number | | Description |
|------------|--------|------------------------------------|
| VDD | GND | |
| 3 | 6 | REF, Xtal |
| 10, 17 | 11, 18 | PCICLK outputs |
| 24 | 23 | 48MHz Fix, Fix Digital, Fix analog |
| 27 | 28 | 3V66 outputs |
| 34 | 37 | 2.5V or 3.3V for 25MHz outputs |
| 40 | 43 | CPU outputs |
| 48 | 47 | CPU Analog, CPU digital |

Table1: QuadRom Frequency Selection Table

| Bit6 | Bit5 | Bit4 | Bit3 | Bit2 | Bit1 | Bit0 | CPU | AGP | PCI | Spread |
|------|------|------|------|------|------|------|--------|-------|-------|-----------------|
| | | FS4 | FS3 | FS2 | FS1 | FS0 | MHz | MHz | MHz | % |
| 0 | 0 | 0 | 0 | 0 | 0 | 0 | 100.00 | 66.67 | 33.33 | 0 to -0.5% Down |
| 0 | 0 | 0 | 0 | 0 | 0 | 1 | 200.00 | 66.67 | 33.33 | 0 to -0.5% Down |
| 0 | 0 | 0 | 0 | 0 | 1 | 0 | 133.33 | 66.67 | 33.33 | 0 to -0.5% Down |
| 0 | 0 | 0 | 0 | 0 | 1 | 1 | 166.67 | 66.67 | 33.33 | 0 to -0.5% Down |
| 0 | 0 | 0 | 0 | 1 | 0 | 0 | 200.00 | 33.33 | 16.67 | 0 to -0.5% Down |
| 0 | 0 | 0 | 0 | 1 | 0 | 1 | 400.00 | 66.67 | 33.33 | 0 to -0.5% Down |
| 0 | 0 | 0 | 0 | 1 | 1 | 0 | 266.67 | 44.58 | 22.29 | 0 to -0.5% Down |
| 0 | 0 | 0 | 0 | 1 | 1 | 1 | 333.33 | 66.67 | 33.33 | 0 to -0.5% Down |
| 0 | 0 | 0 | 1 | 0 | 0 | 0 | 100.99 | 67.33 | 33.66 | 0.25% Center |
| 0 | 0 | 0 | 1 | 0 | 0 | 1 | 201.98 | 67.33 | 33.66 | 0.25% Center |
| 0 | 0 | 0 | 1 | 0 | 1 | 0 | 134.65 | 67.33 | 33.66 | 0.25% Center |
| 0 | 0 | 0 | 1 | 0 | 1 | 1 | 168.31 | 67.32 | 33.66 | No Spread |
| 0 | 0 | 0 | 1 | 1 | 0 | 0 | 115.00 | 76.67 | 38.33 | No Spread |
| 0 | 0 | 0 | 1 | 1 | 0 | 1 | 230.00 | 76.67 | 38.33 | No Spread |
| 0 | 0 | 0 | 1 | 1 | 1 | 0 | 153.33 | 76.66 | 38.33 | No Spread |
| 0 | 0 | 0 | 1 | 1 | 1 | 1 | 191.67 | 76.67 | 38.33 | No Spread |
| 0 | 0 | 1 | 0 | 0 | 0 | 0 | 100.00 | 66.66 | 33.33 | 0.25% Center |
| 0 | 0 | 1 | 0 | 0 | 0 | 1 | 200.00 | 66.66 | 33.33 | 0.25% Center |
| 0 | 0 | 1 | 0 | 0 | 1 | 0 | 133.33 | 66.66 | 33.33 | 0.25% Center |
| 0 | 0 | 1 | 0 | 0 | 1 | 1 | 166.67 | 71.43 | 35.71 | 0.25% Center |
| 0 | 0 | 1 | 0 | 1 | 0 | 0 | 200.00 | 66.66 | 33.33 | 0.25% Center |
| 0 | 0 | 1 | 0 | 1 | 0 | 1 | 400.00 | 66.66 | 33.33 | No Spread |
| 0 | 0 | 1 | 0 | 1 | 1 | 0 | 266.67 | 66.66 | 33.33 | 0.25% Center |
| 0 | 0 | 1 | 0 | 1 | 1 | 1 | 333.33 | 66.66 | 33.33 | 0.25% Center |
| 0 | 0 | 1 | 1 | 0 | 0 | 0 | 105.00 | 69.99 | 35.00 | No Spread |
| 0 | 0 | 1 | 1 | 0 | 0 | 1 | 210.00 | 69.99 | 35.00 | No Spread |
| 0 | 0 | 1 | 1 | 0 | 1 | 0 | 140.00 | 69.99 | 35.00 | No Spread |
| 0 | 0 | 1 | 1 | 0 | 1 | 1 | 175.00 | 69.99 | 35.00 | No Spread |
| 0 | 0 | 1 | 1 | 1 | 0 | 0 | 110.00 | 73.33 | 36.66 | No Spread |
| 0 | 0 | 1 | 1 | 1 | 0 | 1 | 220.00 | 73.33 | 36.66 | No Spread |
| 0 | 0 | 1 | 1 | 1 | 1 | 0 | 146.66 | 73.33 | 36.66 | No Spread |
| 0 | 0 | 1 | 1 | 1 | 1 | 1 | 183.34 | 73.33 | 36.66 | No Spread |

Table1: QuadRom Frequency Selection Table (Continued)

| Bit6 | Bit5 | Bit4 | Bit3 | Bit2 | Bit1 | Bit0 | CPU | AGP | PCI | Spread |
|------|------|------|------|------|------|------|--------|-------|-------|-----------|
| | | FS4 | FS3 | FS2 | FS1 | FS0 | MHz | MHz | MHz | % |
| 0 | 1 | 0 | 0 | 0 | 0 | 0 | 103.00 | 68.66 | 34.33 | No Spread |
| 0 | 1 | 0 | 0 | 0 | 0 | 1 | 206.00 | 68.66 | 34.33 | No Spread |
| 0 | 1 | 0 | 0 | 0 | 1 | 0 | 137.33 | 68.66 | 34.33 | No Spread |
| 0 | 1 | 0 | 0 | 0 | 1 | 1 | 171.67 | 68.66 | 34.33 | No Spread |
| 0 | 1 | 0 | 0 | 1 | 0 | 0 | 228.89 | 68.66 | 34.33 | No Spread |
| 0 | 1 | 0 | 0 | 1 | 0 | 1 | 412.00 | 68.66 | 34.33 | No Spread |
| 0 | 1 | 0 | 0 | 1 | 1 | 0 | 274.67 | 68.66 | 34.33 | No Spread |
| 0 | 1 | 0 | 0 | 1 | 1 | 1 | 343.33 | 68.66 | 34.33 | No Spread |
| 0 | 1 | 0 | 1 | 0 | 0 | 0 | 105.00 | 69.99 | 35.00 | No Spread |
| 0 | 1 | 0 | 1 | 0 | 0 | 1 | 210.00 | 69.99 | 35.00 | No Spread |
| 0 | 1 | 0 | 1 | 0 | 1 | 0 | 140.00 | 69.99 | 35.00 | No Spread |
| 0 | 1 | 0 | 1 | 0 | 1 | 1 | 175.00 | 69.99 | 35.00 | No Spread |
| 0 | 1 | 0 | 1 | 1 | 0 | 0 | 233.33 | 69.99 | 35.00 | No Spread |
| 0 | 1 | 0 | 1 | 1 | 0 | 1 | 420.00 | 69.99 | 35.00 | No Spread |
| 0 | 1 | 0 | 1 | 1 | 1 | 0 | 280.00 | 69.99 | 35.00 | No Spread |
| 0 | 1 | 0 | 1 | 1 | 1 | 1 | 350.00 | 69.99 | 35.00 | No Spread |
| 0 | 1 | 1 | 0 | 0 | 0 | 0 | 107.00 | 71.33 | 35.66 | No Spread |
| 0 | 1 | 1 | 0 | 0 | 0 | 1 | 214.00 | 71.33 | 35.66 | No Spread |
| 0 | 1 | 1 | 0 | 0 | 1 | 0 | 142.66 | 71.33 | 35.66 | No Spread |
| 0 | 1 | 1 | 0 | 0 | 1 | 1 | 178.34 | 71.33 | 35.66 | No Spread |
| 0 | 1 | 1 | 0 | 1 | 0 | 0 | 237.78 | 71.33 | 35.66 | No Spread |
| 0 | 1 | 1 | 0 | 1 | 0 | 1 | 428.00 | 71.33 | 35.66 | No Spread |
| 0 | 1 | 1 | 0 | 1 | 1 | 0 | 285.34 | 71.33 | 35.66 | No Spread |
| 0 | 1 | 1 | 0 | 1 | 1 | 1 | 356.66 | 71.33 | 35.66 | No Spread |
| 0 | 1 | 1 | 1 | 0 | 0 | 0 | 110.00 | 73.33 | 36.66 | No Spread |
| 0 | 1 | 1 | 1 | 0 | 0 | 1 | 220.00 | 73.33 | 36.66 | No Spread |
| 0 | 1 | 1 | 1 | 0 | 1 | 0 | 146.66 | 73.33 | 36.66 | No Spread |
| 0 | 1 | 1 | 1 | 0 | 1 | 1 | 183.34 | 73.33 | 36.66 | No Spread |
| 0 | 1 | 1 | 1 | 1 | 0 | 0 | 244.44 | 73.33 | 36.66 | No Spread |
| 0 | 1 | 1 | 1 | 1 | 0 | 1 | 440.00 | 73.33 | 36.66 | No Spread |
| 0 | 1 | 1 | 1 | 1 | 1 | 0 | 293.34 | 73.33 | 36.66 | No Spread |
| 0 | 1 | 1 | 1 | 1 | 1 | 1 | 366.66 | 73.33 | 36.66 | No Spread |

Table1: QuadRom Frequency Selection Table (Continued)

| Bit6 | Bit5 | Bit4 FS4 | Bit3 FS3 | Bit2 FS2 | Bit1 FS1 | Bit0 FS0 | CPU MHz | AGP MHz | PCI MHz | Spread % |
|------|------|-------------|-------------|-------------|-------------|-------------|------------|------------|------------|-------------|
| 1 | 0 | 0 | 0 | 0 | 0 | 0 | 95.00 | 63.33 | 31.66 | No Spread |
| 1 | 0 | 0 | 0 | 0 | 0 | 1 | 190.00 | 63.33 | 31.66 | No Spread |
| 1 | 0 | 0 | 0 | 0 | 1 | 0 | 126.66 | 63.33 | 31.66 | No Spread |
| 1 | 0 | 0 | 0 | 0 | 1 | 1 | 158.34 | 63.33 | 31.66 | No Spread |
| 1 | 0 | 0 | 0 | 1 | 0 | 0 | 211.11 | 63.33 | 31.66 | No Spread |
| 1 | 0 | 0 | 0 | 1 | 0 | 1 | 380.00 | 63.33 | 31.66 | No Spread |
| 1 | 0 | 0 | 0 | 1 | 1 | 0 | 253.34 | 63.33 | 31.66 | No Spread |
| 1 | 0 | 0 | 0 | 1 | 1 | 1 | 316.66 | 63.33 | 31.66 | No Spread |
| 1 | 0 | 0 | 1 | 0 | 0 | 0 | 90.00 | 59.99 | 30.00 | No Spread |
| 1 | 0 | 0 | 1 | 0 | 0 | 1 | 180.00 | 59.99 | 30.00 | No Spread |
| 1 | 0 | 0 | 1 | 0 | 1 | 0 | 120.00 | 59.99 | 30.00 | No Spread |
| 1 | 0 | 0 | 1 | 0 | 1 | 1 | 150.00 | 59.99 | 30.00 | No Spread |
| 1 | 0 | 0 | 1 | 1 | 0 | 0 | 200.00 | 59.99 | 30.00 | No Spread |
| 1 | 0 | 0 | 1 | 1 | 0 | 1 | 360.00 | 59.99 | 30.00 | No Spread |
| 1 | 0 | 0 | 1 | 1 | 1 | 0 | 240.00 | 59.99 | 30.00 | No Spread |
| 1 | 0 | 0 | 1 | 1 | 1 | 1 | 300.00 | 59.99 | 30.00 | No Spread |
| 1 | 0 | 1 | 0 | 0 | 0 | 0 | 85.00 | 56.66 | 28.33 | No Spread |
| 1 | 0 | 1 | 0 | 0 | 0 | 1 | 170.00 | 56.66 | 28.33 | No Spread |
| 1 | 0 | 1 | 0 | 0 | 1 | 0 | 113.33 | 56.66 | 28.33 | No Spread |
| 1 | 0 | 1 | 0 | 0 | 1 | 1 | 141.67 | 56.66 | 28.33 | No Spread |
| 1 | 0 | 1 | 0 | 1 | 0 | 0 | 188.89 | 56.66 | 28.33 | No Spread |
| 1 | 0 | 1 | 0 | 1 | 0 | 1 | 340.00 | 56.66 | 28.33 | No Spread |
| 1 | 0 | 1 | 0 | 1 | 1 | 0 | 226.67 | 56.66 | 28.33 | No Spread |
| 1 | 0 | 1 | 0 | 1 | 1 | 1 | 283.33 | 56.66 | 28.33 | No Spread |
| 1 | 0 | 1 | 1 | 0 | 0 | 0 | 80.00 | 53.33 | 26.66 | No Spread |
| 1 | 0 | 1 | 1 | 0 | 0 | 1 | 160.00 | 53.33 | 26.66 | No Spread |
| 1 | 0 | 1 | 1 | 0 | 1 | 0 | 106.66 | 53.33 | 26.66 | No Spread |
| 1 | 0 | 1 | 1 | 0 | 1 | 1 | 133.34 | 53.33 | 26.66 | No Spread |
| 1 | 0 | 1 | 1 | 1 | 0 | 0 | 177.78 | 53.33 | 26.66 | No Spread |
| 1 | 0 | 1 | 1 | 1 | 0 | 1 | 320.00 | 53.33 | 26.66 | No Spread |
| 1 | 0 | 1 | 1 | 1 | 1 | 0 | 213.34 | 53.33 | 26.66 | No Spread |
| 1 | 0 | 1 | 1 | 1 | 1 | 1 | 266.66 | 53.33 | 26.66 | No Spread |

Table1: QuadRom Frequency Selection Table (Continued)

| Bit6 | Bit5 | Bit4 FS4 | Bit3 FS3 | Bit2 FS2 | Bit1 FS1 | Bit0 FS0 | CPU MHz | AGP MHz | PCI MHz | Spread % |
|------|------|-------------|-------------|-------------|-------------|-------------|------------|------------|------------|-------------|
| 1 | 1 | 0 | 0 | 0 | 0 | 0 | 115.00 | 76.66 | 38.33 | No Spread |
| 1 | 1 | 0 | 0 | 0 | 0 | 1 | 230.00 | 76.66 | 38.33 | No Spread |
| 1 | 1 | 0 | 0 | 0 | 1 | 0 | 153.33 | 76.66 | 38.33 | No Spread |
| 1 | 1 | 0 | 0 | 0 | 1 | 1 | 191.67 | 76.66 | 38.33 | No Spread |
| 1 | 1 | 0 | 0 | 1 | 0 | 0 | 255.55 | 76.66 | 38.33 | No Spread |
| 1 | 1 | 0 | 0 | 1 | 0 | 1 | 460.00 | 76.66 | 38.33 | No Spread |
| 1 | 1 | 0 | 0 | 1 | 1 | 0 | 306.67 | 76.66 | 38.33 | No Spread |
| 1 | 1 | 0 | 0 | 1 | 1 | 1 | 383.33 | 76.66 | 38.33 | No Spread |
| 1 | 1 | 0 | 1 | 0 | 0 | 0 | 115.00 | 79.99 | 40.00 | No Spread |
| 1 | 1 | 0 | 1 | 0 | 0 | 1 | 230.00 | 79.99 | 40.00 | No Spread |
| 1 | 1 | 0 | 1 | 0 | 1 | 0 | 153.33 | 79.99 | 40.00 | No Spread |
| 1 | 1 | 0 | 1 | 0 | 1 | 1 | 191.67 | 79.99 | 40.00 | No Spread |
| 1 | 1 | 0 | 1 | 1 | 0 | 0 | 255.55 | 79.99 | 40.00 | No Spread |
| 1 | 1 | 0 | 1 | 1 | 0 | 1 | 460.00 | 79.99 | 40.00 | No Spread |
| 1 | 1 | 0 | 1 | 1 | 1 | 0 | 306.67 | 79.99 | 40.00 | No Spread |
| 1 | 1 | 0 | 1 | 1 | 1 | 1 | 383.33 | 79.99 | 40.00 | No Spread |
| 1 | 1 | 1 | 0 | 0 | 0 | 0 | 78.00 | 51.99 | 26.00 | No Spread |
| 1 | 1 | 1 | 0 | 0 | 0 | 1 | 156.00 | 51.99 | 26.00 | No Spread |
| 1 | 1 | 1 | 0 | 0 | 1 | 0 | 104.00 | 51.99 | 26.00 | No Spread |
| 1 | 1 | 1 | 0 | 0 | 1 | 1 | 130.00 | 51.99 | 26.00 | No Spread |
| 1 | 1 | 1 | 0 | 1 | 0 | 0 | 173.33 | 51.99 | 26.00 | No Spread |
| 1 | 1 | 1 | 0 | 1 | 0 | 1 | 312.00 | 51.99 | 26.00 | No Spread |
| 1 | 1 | 1 | 0 | 1 | 1 | 0 | 208.00 | 51.99 | 26.00 | No Spread |
| 1 | 1 | 1 | 0 | 1 | 1 | 1 | 260.00 | 51.99 | 26.00 | No Spread |
| 1 | 1 | 1 | 1 | 0 | 0 | 0 | 75.00 | 50.00 | 25.00 | No Spread |
| 1 | 1 | 1 | 1 | 0 | 0 | 1 | 150.00 | 50.00 | 25.00 | No Spread |
| 1 | 1 | 1 | 1 | 0 | 1 | 0 | 100.00 | 50.00 | 25.00 | No Spread |
| 1 | 1 | 1 | 1 | 0 | 1 | 1 | 125.00 | 50.00 | 25.00 | No Spread |
| 1 | 1 | 1 | 1 | 1 | 0 | 0 | 166.67 | 50.00 | 25.00 | No Spread |
| 1 | 1 | 1 | 1 | 1 | 0 | 1 | 300.00 | 50.00 | 25.00 | No Spread |
| 1 | 1 | 1 | 1 | 1 | 1 | 0 | 200.00 | 50.00 | 25.00 | No Spread |
| 1 | 1 | 1 | 1 | 1 | 1 | 1 | 250.00 | 50.00 | 25.00 | No Spread |

General I²C serial interface information for the ICS952926

How to Write:

- Controller (host) sends a start bit.
- Controller (host) sends the write address D2_(H)
- ICS clock will **acknowledge**
- Controller (host) sends the beginning byte location = N
- ICS clock will **acknowledge**
- Controller (host) sends the data byte count = X
- ICS clock will **acknowledge**
- Controller (host) starts sending **Byte N through Byte N + X - 1**
(see Note 2)
- ICS clock will **acknowledge** each byte **one at a time**
- Controller (host) sends a Stop bit

How to Read:

- Controller (host) will send start bit.
- Controller (host) sends the write address D2_(H)
- ICS clock will **acknowledge**
- Controller (host) sends the beginning byte location = N
- ICS clock will **acknowledge**
- Controller (host) will send a separate start bit.
- Controller (host) sends the read address D3_(H)
- ICS clock will **acknowledge**
- ICS clock will send the data byte count = X
- ICS clock sends **Byte N + X - 1**
- ICS clock sends **Byte 0 through byte X (if X_(H) was written to byte 8).**
- Controller (host) will need to acknowledge each byte
- Controller (host) will send a not acknowledge bit
- Controller (host) will send a stop bit

| Index Block Write Operation | | |
|---------------------------------|-----------|----------------------|
| Controller (Host) | | ICS (Slave/Receiver) |
| T | starT bit | |
| Slave Address D2 _(H) | | |
| WR | WRite | |
| | | ACK |
| Beginning Byte = N | | |
| | | ACK |
| Data Byte Count = X | | |
| | | ACK |
| Beginning Byte N | | |
| | X Byte | ACK |
| ○ | | ○ |
| ○ | | ○ |
| ○ | | ○ |
| Byte N + X - 1 | | |
| | | ACK |
| P | stoP bit | |

| Index Block Read Operation | | | |
|---------------------------------|-----------------|----------------------|------------------|
| Controller (Host) | | ICS (Slave/Receiver) | |
| T | starT bit | | |
| Slave Address D2 _(H) | | | |
| WR | WRite | | |
| | | ACK | |
| Beginning Byte = N | | | |
| | | ACK | |
| RT | Repeat starT | | |
| Slave Address D3 _(H) | | | |
| RD | ReaD | | |
| | | ACK | |
| | | | |
| | | Data Byte Count = X | |
| ACK | | | |
| | | X Byte | |
| ACK | | | Beginning Byte N |
| ○ | | | ○ |
| ○ | | | ○ |
| ○ | | | ○ |
| | | Byte N + X - 1 | |
| N | Not acknowledge | | |
| P | stoP bit | | |

I²C Table: Frequency Select Register

| Byte 0 | Pin # | Name | Control Function | Type | 0 | 1 | PWD |
|--------|-------|-----------|--------------------------|------|--|-----|-----|
| Bit 7 | - | FS Source | Frequency H/W IIC Select | RW | Latch Inputs | IIC | 0 |
| Bit 6 | - | FS6 | Freq Select Bit 6 | RW | See Table 1: QuadRom Frequency Selection Table | | 0 |
| Bit 5 | - | FS5 | Freq Select Bit 5 | RW | | | 0 |
| Bit 4 | - | FS4 | Freq Select Bit 4 | RW | | | 0 |
| Bit 3 | - | FS3 | Freq Select Bit 3 | RW | | | 0 |
| Bit 2 | - | FS2 | Freq Select Bit 2 | RW | | | 0 |
| Bit 1 | - | FS1 | Freq Select Bit 1 | RW | | | 0 |
| Bit 0 | - | FS0 | Freq Select Bit 0 | RW | | | 0 |

I²C Table: Spreading and Device Behavior Control Register

| Byte 1 | Pin # | Name | Control Function | Type | 0 | 1 | PWD |
|--------|--------|------------------------------------|--------------------------|------|------------|------------|-----|
| Bit 7 | - | SS1 | Spread Select 1** | RW | 00 = 0.20% | 10 = 0.35% | 0 |
| Bit 6 | - | SS0 | Spread Select 0** | RW | 01 = 0.25% | Reserved | 1 |
| Bit 5 | - | SS_EN | Spread Enable Control | RW | ON | OFF | 1 |
| Bit 4 | - | WDS_EN | WD Soft Reset Enable | RW | ON | OFF | 0 |
| Bit 3 | 33 | SEL PD/WOL_STOP | Selects PD# or WOL_STOP# | RW | PD# | WOL_STOP# | 1 |
| Bit 2 | 45, 44 | CPUCLKT/C_ITP, CPU1T/C, CPU0T/C | Output Control | RW | Disable | Enable | 1 |
| Bit 1 | 42,41 | CPUCLKT/C_1 | Output Control | RW | Disable | Enable | 1 |
| Bit 0 | 39, 38 | CPUCLKT/C_0 | Output Control | RW | Disable | Enable | 1 |

** Spread programming only applies for ROM table entries 0001000 to 0001011 and 0010000 to 0010111

I²C Table: Output Control Register

| Byte 2 | Pin # | Name | Control Function | Type | 0 | 1 | PWD |
|--------|--------|----------------|--|------|--------------|-----------|-----|
| Bit 7 | 36 | 25MHz_0 | Output Control | RW | Disable | Enable | 1 |
| Bit 6 | 35 | 25MHz_1 | Output Control | RW | Disable | Enable | 1 |
| Bit 5 | - | CPUT Stop Mode | 0: CPUT Driven during PD#; 1: Tri-stated | RW | Driven | Hi-Z | 0 |
| Bit 4 | 36 | 25Mhz0 | Free running control during WOL_STOP | RW | Free-Running | Stoppable | 0 |
| Bit 3 | 26 | 3V66_1 | Output Control | RW | Disable | Enable | 1 |
| Bit 2 | - | Reserved | Reserved | RW | - | - | 1 |
| Bit 1 | 42,41 | CPUCLKT/C_1 | Output Stop Control | RW | Free Run | Stoppable | 1 |
| Bit 0 | 39, 38 | CPUCLKT/C_0 | Output Stop Control | RW | Free Run | Stoppable | 1 |

I²C Table: Output Control Register

| Byte 3 | Pin # | Name | Control Function | Type | 0 | 1 | PWD |
|--------|-------|---------|----------------------|------|---------------------------------------|--------|-----|
| Bit 7 | - | ASEL1 | 3V66/PCI Freq Select | RW | See Table 5: Async AGP/PCI Freq Table | | 0 |
| Bit 6 | 20 | PCICLK6 | Output Control | RW | Disable | Enable | 1 |
| Bit 5 | 19 | PCICLK5 | Output Control | RW | Disable | Enable | 1 |
| Bit 4 | 16 | PCICLK4 | Output Control | RW | Disable | Enable | 1 |
| Bit 3 | 15 | PCICLK3 | Output Control | RW | Disable | Enable | 1 |
| Bit 2 | 14 | PCICLK2 | Output Control | RW | Disable | Enable | 1 |
| Bit 1 | 13 | PCICLK1 | Output Control | RW | Disable | Enable | 1 |
| Bit 0 | 12 | PCICLK0 | Output Control | RW | Disable | Enable | 1 |

Table 5: Asynchronous 3V66/PCI Frequency Table

| Byte6 Bit7 | Byte3 Bit7 | 3V66/PCI Frequency |
|------------|------------|--------------------|
| 0 | 0 | 66.66/33.33 |
| 0 | 1 | 80.00/40.00 |
| 1 | 0 | 72.73/36.36 |

I²C Table: Output Control Register

| Byte 4 | Pin # | Name | Control Function | Type | 0 | 1 | PWD |
|--------|-------|----------------------------|---|------|--------------|--------------|-----|
| Bit 7 | - | 48MHz_0 2x output drive | 0=2x drive | RW | 2x drive | normal | 1 |
| Bit 6 | - | PCI ADIV | PCI Async Divider Cntr | RW | AGP/2 | PLL3 Freq/24 | 0 |
| Bit 5 | 35 | 25Mhz1 | Free running control during WOL_STOP | RW | Free-Running | Stoppable | 1 |
| Bit 4 | 29 | 3V66_0 | Output Control | RW | Disable | Enable | 1 |
| Bit 3 | - | Reserved | Reserved | RW | - | - | 1 |
| Bit 2 | 9 | PCICLK_F2 | Output Control | RW | Disable | Enable | 1 |
| Bit 1 | 8 | PCICLK_F1 | Output Control | RW | Disable | Enable | 1 |
| Bit 0 | 7 | PCICLK_F0 | Output Control | RW | Disable | Enable | 1 |

I²C Table: Reserved Register

| Byte 5 | Pin # | Name | Control Function | Type | 0 | 1 | PWD |
|--------|-------|-------------|--|------|---|--------|-----|
| Bit 7 | - | Reserved | Reserved | RW | - | - | 0 |
| Bit 6 | - | Mode Sel1 | PLL Mode Selection Bits | RW | See Table 4: Mode Selection Table | | 0 |
| Bit 5 | - | Mode Sel0 | | RW | | | 0 |
| Bit 4 | 25 | 3V66_2 | Output Control | RW | Disable | Enable | 1 |
| Bit 3 | - | M PLL2 Div3 | M Divider Programming bits for Async mode 2&3 | RW | The decimal representation of M PLL2 Div (3:0) + 2 is equal to REF divider value for PLL2 | | X |
| Bit 2 | - | M PLL2 Div2 | | RW | | | X |
| Bit 1 | - | M PLL2 Div1 | | RW | | | X |
| Bit 0 | - | M PLL2 Div0 | | RW | | | X |

Table 4: Mode Selection Table

| Mode | Standard Overclock Mode(I) | CPU Overclock Mode(II) | Graphic Overclock Mode(III) |
|----------------|----------------------------------|------------------------------|------------------------------|
| IIC Control | Byte 5 bit(6:5) = 00 | Byte 5 bit(6:5) = 01 | Byte 5 bit(6:5) = 10 |
| 25MHz From? | PLL3 | PLL3 | PLL1 |
| 3V66/PCI From? | PLL1 (Needed to be align w/ CPU) | PLL3 | PLL3 |
| Spreading | CPU/3V66/PCI have spread | Only CPU clocks have spread. | Only CPU clocks have spread. |

I²C Table: Vendor & Revision ID Register

| Byte 6 | Pin # | Name | Control Function | Type | 0 | 1 | PWD |
|--------|-------|-------------|--|------|--|---|-----|
| Bit 7 | - | ASEL0 | 3V66/PCI Freq Select | RW | See Table 5: Async AGP/PCI Freq Table | | 0 |
| Bit 6 | - | N PLL2 Div6 | N Divider Programming bits for Async mode 2&3 | RW | The decimal representation of N PLL2 Div (6:0) + 8 is equal to VCO divider value for PLL2. | | X |
| Bit 5 | - | N PLL2 Div5 | | RW | | | X |
| Bit 4 | - | N PLL2 Div4 | | RW | | | X |
| Bit 3 | - | N PLL2 Div3 | | RW | | | X |
| Bit 2 | - | N PLL2 Div2 | | RW | | | X |
| Bit 1 | - | N PLL2 Div1 | | RW | | | X |
| Bit 0 | - | N PLL2 Div0 | | RW | | | X |

I²C Table: Vendor & Revision ID Register

| Byte 7 | Pin # | Name | Control Function | Type | 0 | 1 | PWD |
|--------|-------|------|------------------|------|---|---|-----|
| Bit 7 | - | RID3 | REVISION ID | R | - | - | 0 |
| Bit 6 | - | RID2 | | R | - | - | 0 |
| Bit 5 | - | RID1 | | R | - | - | 1 |
| Bit 4 | - | RID0 | | R | - | - | 0 |
| Bit 3 | - | VID3 | VENDOR ID | R | - | - | 0 |
| Bit 2 | - | VID2 | | R | - | - | 0 |
| Bit 1 | - | VID1 | | R | - | - | 0 |
| Bit 0 | - | VID0 | | R | - | - | 1 |

I²C Table: Byte Count Register

| Byte 8 | Pin # | Name | Control Function | Type | 0 | 1 | PWD |
|--------|-------|------|----------------------------------|------|---|---|-----|
| Bit 7 | - | BC7 | Byte Count Programming b(7:0) | RW | Writing to this register will configure how many bytes will be read back, default is 0F = 15 bytes. | | 0 |
| Bit 6 | - | BC6 | | RW | | | 0 |
| Bit 5 | - | BC5 | | RW | | | 0 |
| Bit 4 | - | BC4 | | RW | | | 0 |
| Bit 3 | - | BC3 | | RW | | | 1 |
| Bit 2 | - | BC2 | | RW | | | 1 |
| Bit 1 | - | BC1 | | RW | | | 1 |
| Bit 0 | - | BC0 | | RW | | | 1 |

I²C Table: Watchdog Timer Register

| Byte 9 | Pin # | Name | Control Function | Type | 0 | 1 | PWD |
|--------|-------|------|------------------|------|---|---|-----|
| Bit 7 | - | WD7 | WD Timer Bit 7 | RW | These bits represent X*290ms the watchdog timer waits before it goes to alarm mode. Default is 11 x 293ms = 3.2s. | | 0 |
| Bit 6 | - | WD6 | WD Timer Bit 6 | RW | | | 0 |
| Bit 5 | - | WD5 | WD Timer Bit 5 | RW | | | 0 |
| Bit 4 | - | WD4 | WD Timer Bit 4 | RW | | | 0 |
| Bit 3 | - | WD3 | WD Timer Bit 3 | RW | | | 1 |
| Bit 2 | - | WD2 | WD Timer Bit 2 | RW | | | 0 |
| Bit 1 | - | WD1 | WD Timer Bit 1 | RW | | | 1 |
| Bit 0 | - | WD0 | WD Timer Bit 0 | RW | | | 1 |

I²C Table: VCO Control Select Bit & WD Timer Control Register

| Byte 10 | Pin # | Name | Control Function | Type | 0 | 1 | PWD |
|---------|-------|--------|---|------|--|---------------|-----|
| Bit 7 | - | M/NEN | M/N Programming Enable | RW | Disable | Enable | 0 |
| Bit 6 | - | WDEN | Watchdog Enable | R | Disable | Enable | 0 |
| Bit 5 | - | WDFSEN | WD Safe Frequency Mode | RW | Latched FS/Byte0 | WD B10 b(4:0) | 0 |
| Bit 4 | - | WD SF4 | Watch Dog Safe Freq Programming bits | RW | Writing to these bit will configure the safe frequency as Byte0 bit (4:0). | | 0 |
| Bit 3 | - | WD SF3 | | RW | | | 0 |
| Bit 2 | - | WD SF2 | | RW | | | 0 |
| Bit 1 | - | WD SF1 | | RW | | | 0 |
| Bit 0 | - | WD SF0 | | RW | | | 0 |

I²C Table: VCO Frequency Control Register

| Byte 11 | Pin # | Name | Control Function | Type | 0 | 1 | PWD |
|---------|-------|--------|----------------------------|------|--|---|-----|
| Bit 7 | - | N Div8 | N Divider Prog bit 8 | RW | The decimal representation of M and N Divider in Byte 11 and 12 will configure the VCO frequency. Default at power up = latch-in or Byte 0 Rom table. VCO Frequency = 14.318 x [NDiv(8:0)+8] / [MDiv(6:0)+2] | | X |
| Bit 6 | - | M Div6 | M Divider Programming bits | RW | | | X |
| Bit 5 | - | M Div5 | | RW | | | X |
| Bit 4 | - | M Div4 | | RW | | | X |
| Bit 3 | - | M Div3 | | RW | | | X |
| Bit 2 | - | M Div2 | | RW | | | X |
| Bit 1 | - | M Div1 | | RW | | | X |
| Bit 0 | - | M Div0 | | RW | | | X |

I²C Table: VCO Frequency Control Register

| Byte 12 | Pin # | Name | Control Function | Type | 0 | 1 | PWD |
|---------|-------|--------|------------------------------|------|---|---|-----|
| | | | | | | | |
| Bit 7 | - | N Div7 | N Divider Programming b(8:0) | RW | The decimal representation of M and N Divier in Byte 11 and 12 will configure the VCO frequency. Default at power up = latch-in or Byte 0 Rom table. VCO Frequency = 14.318 x [NDiv(8:0)+8] / [MDiv(6:0)+2] | | X |
| Bit 6 | - | N Div6 | | RW | | | X |
| Bit 5 | - | N Div5 | | RW | | | X |
| Bit 4 | - | N Div4 | | RW | | | X |
| Bit 3 | - | N Div3 | | RW | | | X |
| Bit 2 | - | N Div2 | | RW | | | X |
| Bit 1 | - | N Div1 | | RW | | | X |
| Bit 0 | - | N Div0 | | RW | | | X |

I²C Table: Spread Spectrum Control Register

| Byte 13 | Pin # | Name | Control Function | Type | 0 | 1 | PWD |
|---------|-------|------|------------------------------------|------|--|---|-----|
| | | | | | | | |
| Bit 7 | - | SSP7 | Spread Spectrum Programming b(7:0) | RW | These Spread Spectrum bits in Byte 13 and 14 will program the spread percentage. It is recommended to use ICS Spread % table for spread programming. | | X |
| Bit 6 | - | SSP6 | | RW | | | X |
| Bit 5 | - | SSP5 | | RW | | | X |
| Bit 4 | - | SSP4 | | RW | | | X |
| Bit 3 | - | SSP3 | | RW | | | X |
| Bit 2 | - | SSP2 | | RW | | | X |
| Bit 1 | - | SSP1 | | RW | | | X |
| Bit 0 | - | SSP0 | | RW | | | X |

I²C Table: Spread Spectrum Control Register

| Byte 14 | Pin # | Name | Control Function | Type | 0 | 1 | PWD |
|---------|-------|----------|-------------------------------------|------|--|---|-----|
| | | | | | | | |
| Bit 7 | - | Reserved | Reserved | R | - | - | 0 |
| Bit 6 | - | Reserved | Reserved | R | - | - | 0 |
| Bit 5 | - | SSP13 | Spread Spectrum Programming b(13:8) | RW | These Spread Spectrum bits in Byte 13 and 14 will program the spread percentage. It is recommended to use ICS Spread % table for spread programming. | | X |
| Bit 4 | - | SSP12 | | RW | | | X |
| Bit 3 | - | SSP11 | | RW | | | X |
| Bit 2 | - | SSP10 | | RW | | | X |
| Bit 1 | - | SSP9 | | RW | | | X |
| Bit 0 | - | SSP8 | | RW | | | X |

I²C Table: Output Divider Control Register

| Byte 15 | Pin # | Name | Control Function | Type | 0 | | 1 | | PWD |
|---------|-------|------------|--------------------------------------|------|---------|----------|----------|----------|-----|
| | | | | | | | | | |
| Bit 7 | - | 25MHz Div3 | 25MHz Divider Ratio Programming Bits | RW | 0000:/2 | 0100:/4 | 1000:/8 | 1100:/16 | X |
| Bit 6 | - | 25Mhz Div2 | | RW | 0001:/3 | 0101:/6 | 1001:/12 | 1101:/24 | X |
| Bit 5 | - | 25MHz Div1 | | RW | 0010:/5 | 0110:/10 | 1010:/20 | 1110:/40 | X |
| Bit 4 | - | 25MHz Div0 | | RW | 0011:/7 | 0111:/14 | 1011:/28 | 1111:/56 | X |
| Bit 3 | - | CPU Div3 | CPUDivider Ratio Programming Bits | RW | 0000:/2 | 0100:/4 | 1000:/8 | 1100:/16 | X |
| Bit 2 | - | CPU Div2 | | RW | 0001:/3 | 0101:/6 | 1001:/12 | 1101:/24 | X |
| Bit 1 | - | CPU Div1 | | RW | 0010:/5 | 0110:/10 | 1010:/20 | 1110:/40 | X |
| Bit 0 | - | CPU Div0 | | RW | 0011:/7 | 0111:/14 | 1011:/28 | 1111:/56 | X |

I²C Table: Output Divider Control Register

| Byte 16 | Pin # | Name | Control Function | Type | 0 | 1 | PWD | | |
|---------|-------|----------|--|------|---------|----------|----------|----------|---|
| | | | | | | | | | |
| Bit 7 | - | Reserved | Reserved | RW | - | - | X | | |
| Bit 6 | - | Reserved | | RW | - | - | X | | |
| Bit 5 | - | Reserved | | RW | - | - | X | | |
| Bit 4 | - | Reserved | | RW | - | - | X | | |
| Bit 3 | - | 3V66Div3 | 3V66/PCI Divider Ratio Programming Bits for Mode 1 | RW | 0000:/2 | 0100:/4 | 1000:/8 | 1100:/16 | X |
| Bit 2 | - | 3V66Div2 | | RW | 0001:/3 | 0101:/6 | 1001:/12 | 1101:/24 | X |
| Bit 1 | - | 3V66Div1 | | RW | 0010:/5 | 0110:/10 | 1010:/20 | 1110:/40 | X |
| Bit 0 | - | 3V66Div0 | | RW | 0011:/7 | 0111:/14 | 1011:/28 | 1111:/56 | X |

I²C Table: Output Divider Control Register

| Byte 17 | Pin # | Name | Control Function | Type | 0 | | 1 | | PWD |
|---------|-------|----------|------------------|------|---------|---------|---|---|-----|
| | | | | | | | | | |
| Bit 7 | - | Reserved | Reserved | RW | - | - | - | - | X |
| Bit 6 | - | Reserved | Reserved | RW | - | - | - | - | X |
| Bit 5 | - | Reserved | Reserved | RW | - | - | - | - | X |
| Bit 4 | - | CPUINV | CPU Phase Invert | RW | Default | Inverse | - | - | X |
| Bit 3 | - | Reserved | Reserved | RW | - | - | - | - | 1 |
| Bit 2 | - | Reserved | Reserved | RW | - | - | - | - | 1 |
| Bit 1 | - | Reserved | Reserved | RW | - | - | - | - | 1 |
| Bit 0 | - | Reserved | Reserved | RW | - | - | - | - | 1 |

I²C Table: Group Skew Control Register

| Byte 18 | Pin # | Name | Control Function | Type | 0 | | 1 | | PWD |
|---------|-------|----------|------------------|------|---|---|---|---|-----|
| | | | | | | | | | |
| Bit 7 | - | Reserved | Reserved | RW | - | - | - | - | 0 |
| Bit 6 | - | Reserved | Reserved | RW | - | - | - | - | 0 |
| Bit 5 | - | Reserved | Reserved | RW | - | - | - | - | 0 |
| Bit 4 | - | Reserved | Reserved | RW | - | - | - | - | 0 |
| Bit 3 | - | Reserved | Reserved | RW | - | - | - | - | 0 |
| Bit 2 | - | Reserved | Reserved | RW | - | - | - | - | 0 |
| Bit 1 | - | Reserved | Reserved | RW | - | - | - | - | 0 |
| Bit 0 | - | Reserved | Reserved | RW | - | - | - | - | 0 |

I²C Table: Group Skew Control Register

| Byte 19 | Pin # | Name | Control Function | Type | 0 | | 1 | | PWD |
|---------|-------|----------|-----------------------------------|------|----------|----------|----------|----------|-----|
| | | | | | | | | | |
| Bit 7 | - | 3V66Skw3 | CPU-3V66 7 Step Skew Control (ps) | RW | 0000:0 | 0100:150 | 1000:300 | 1100:450 | 1 |
| Bit 6 | - | 3V66Skw2 | | RW | 0001:N/A | 0101:N/A | 1001:N/A | 1101:600 | 1 |
| Bit 5 | - | 3V66Skw1 | | RW | 0010:N/A | 0110:N/A | 1010:N/A | 1110:750 | 0 |
| Bit 4 | - | 3V66Skw0 | | RW | 0011:N/A | 0111:N/A | 1011:N/A | 1111:900 | 0 |
| Bit 3 | - | PCISkw3 | CPU-PCI 7 Step Skew Control (ps) | RW | 0000:0 | 0100:150 | 1000:300 | 1100:450 | 1 |
| Bit 2 | - | PCISkw2 | | RW | 0001:N/A | 0101:N/A | 1001:N/A | 1101:600 | 1 |
| Bit 1 | - | PCISkw1 | | RW | 0010:N/A | 0110:N/A | 1010:N/A | 1110:750 | 0 |
| Bit 0 | - | PCISkw0 | | RW | 0011:N/A | 0111:N/A | 1011:N/A | 1111:900 | 0 |

I²C Table: Group Skew Control Register

| Byte 20 | Pin # | Name | Control Function | Type | 0 | | 1 | | PWD |
|---------|-------|----------|---|------|----------|----------|----------|----------|-----|
| | | | | | | | | | |
| Bit 7 | - | PCISkw3 | CPU-PCI F(2:0) 7 Step Skew Control (ps) | RW | 0000:0 | 0100:150 | 1000:300 | 1100:450 | 1 |
| Bit 6 | - | PCISkw2 | | RW | 0001:N/A | 0101:N/A | 1001:N/A | 1101:600 | 1 |
| Bit 5 | - | PCISkw1 | | RW | 0010:N/A | 0110:N/A | 1010:N/A | 1110:750 | 0 |
| Bit 4 | - | PCISkw0 | | RW | 0011:N/A | 0111:N/A | 1011:N/A | 1111:900 | 0 |
| Bit 3 | - | Reserved | Reserved | RW | - | - | - | - | 0 |
| Bit 2 | - | Reserved | Reserved | RW | - | - | - | - | 0 |
| Bit 1 | - | Reserved | Reserved | RW | - | - | - | - | 0 |
| Bit 0 | - | Reserved | Reserved | RW | - | - | - | - | 0 |

I²C Table: Slew Rate Control Register

| Byte 21 | Pin # | Name | Control Function | Type | 0 | | 1 | | PWD |
|---------|-------|----------|-------------------------------|------|------------|------------|---|---|-----|
| | | | | | | | | | |
| Bit 7 | - | PCIFStr1 | PCICLK (2:0) Strength Control | RW | 00 = 0.63X | 10 = 0.88X | - | - | 1 |
| Bit 6 | - | PCIFStr0 | | | 01 = 0.75X | 11 = 1.00X | - | - | 1 |
| Bit 5 | - | PCIFStr1 | | | - | - | - | - | - |
| Bit 4 | - | PCIFStr0 | PCICLK (6) Strength Control | RW | 00 = 0.63X | 10 = 0.88X | - | - | 1 |
| Bit 3 | - | Reserved | | | 01 = 0.75X | 11 = 1.00X | - | - | 1 |
| Bit 2 | - | Reserved | Reserved | RW | - | - | - | - | 1 |
| Bit 1 | - | AGPStr1 | AGPCLK Strength Control | RW | 00 = 0.70X | 10 = 0.90X | - | - | 1 |
| Bit 0 | - | AGPStr0 | | | 01 = 0.80X | 11 = 1.00X | - | - | 1 |

I²C Table: Slew Rate Control Register

| Byte 22 | Pin # | Name | Control Function | Type | 0 | 1 | PWD |
|---------|-------|----------|-------------------------------|------|-------------|-------------|-----|
| Bit 7 | - | REF_Slw | REF Slew Rate Control | RW | 00 = Medium | 10 = Strong | 1 |
| Bit 6 | - | | | RW | 01 = Weak | 11 = N/A | 0 |
| Bit 5 | - | PCIFStr1 | PCICLK (5) Strength Control | RW | 00 = 0.63X | 10 = 0.88X | 1 |
| Bit 4 | - | PCIFStr0 | | | 01 = 0.75X | 11 = 1.00X | 1 |
| Bit 3 | - | PCIFStr1 | PCICLK (4:2) Strength Control | RW | 00 = 0.63X | 10 = 0.88X | 1 |
| Bit 2 | - | PCIFStr0 | | | 01 = 0.75X | 11 = 1.00X | 1 |
| Bit 1 | - | PCIFStr1 | PCICLK (1:0) Strength Control | RW | 00 = 0.63X | 10 = 0.88X | 1 |
| Bit 0 | - | PCIFStr0 | | | 01 = 0.75X | 11 = 1.00X | 1 |

I²C Table: Output Control Register

| Byte 23 | Pin # | Name | Control Function | Type | 0 | 1 | PWD |
|---------|-------|----------|------------------|------|---------|--------|-----|
| Bit 7 | - | 48MHz_0 | Output Control | RW | Disable | Enable | 1 |
| Bit 6 | - | 24_48MHz | Output Control | RW | Disable | Enable | 1 |
| Bit 5 | - | REF1 | Output Control | RW | Disable | Enable | 1 |
| Bit 4 | - | REF0 | Output Control | RW | Disable | Enable | 1 |
| Bit 3 | - | REF2 | Output Control | RW | Disable | Enable | 1 |
| Bit 2 | - | 48MHz_1 | Output Control | RW | Disable | Enable | 1 |
| Bit 1 | - | Reserved | Reserved | RW | - | - | 0 |
| Bit 0 | - | Reserved | Reserved | RW | - | - | 0 |

I²C Table: Read Back Register

| Byte 24 | Pin # | Name | Control Function | Type | 0 | 1 | PWD |
|---------|-------|----------|--------------------------------|------|---|---|-----|
| Bit 7 | - | WDHRB | WD Hard Alarm Status Read back | R | - | - | X |
| Bit 6 | - | WDSRB | WD Soft Alarm Status Read back | R | - | - | X |
| Bit 5 | - | Reserved | Reserved | R | - | - | 0 |
| Bit 4 | - | FS4RB | FS4 Read back | R | - | - | X |
| Bit 3 | - | FS3RB | FS3 Read back | R | - | - | X |
| Bit 2 | - | FS2RB | FS2 Read back | R | - | - | X |
| Bit 1 | - | FS1RB | FS1 Read back | R | - | - | X |
| Bit 0 | - | FS0RB | FS0 Read back | R | - | - | X |

Absolute Maximum Ratings

| | |
|-------------------------------|---------------------------------------|
| Core Operating Voltage | 4.6 V |
| I/O Operating Voltage | 3.6V |
| Logic Inputs | GND -0.5 V to V _{DD} + 0.5 V |
| Ambient Operating Temperature | 0°C to +70°C |
| Storage Temperature | -65°C to +150°C |
| Case Temperature | 115°C |

Stresses above those listed under *Absolute Maximum Ratings* may cause permanent damage to the device. These ratings are stress specifications only and functional operation of the device at these or any other conditions above those listed in the operational sections of the specifications is not implied. Exposure to absolute maximum rating conditions for extended periods may affect product reliability.

Electrical Characteristics - Input/Supply/Common Output Parameters

T_A = 0 - 70°C; Supply Voltage V_{DD} = 3.3 V +/-5%

| PARAMETER | SYMBOL | CONDITIONS | MIN | TYP | MAX | UNITS | NOTES |
|----------------------------------|----------------------|---|----------------------|----------|-----------------------|-------|-------|
| Input High Voltage | V _{IH} | 3.3V +/-5% | 2 | | V _{DD} + 0.3 | V | |
| Input MID Voltage | V _{MID} | 3.3V +/-5% | 1 | | 1.8 | V | |
| Input Low Voltage | V _{IL} | 3.3V +/-5% | V _{SS} -0.3 | | 0.8 | V | |
| Input High Current | I _{IH} | V _{IN} = V _{DD} | -5 | | 5 | uA | |
| Input Low Current | I _{IL1} | V _{IN} = 0 V; Inputs with no pull-up resistors | -5 | | | uA | |
| | I _{IL2} | V _{IN} = 0 V; Inputs with pull-up resistors | -200 | | | uA | |
| Operating Supply Current | I _{DD3.3OP} | Full Active, C _L = Full load; | | | 350 | mA | |
| Powerdown Current | I _{DD3.3PD} | all diff pairs driven | | | 35 | mA | |
| | | all differential pairs tri-stated | | | 12 | mA | |
| Input Frequency ³ | F _i | V _{DD} = 3.3 V | | 14.31818 | | MHz | 3 |
| Pin Inductance ¹ | L _{pin} | | | | 7 | nH | 1 |
| Input Capacitance ¹ | C _{IN} | Logic Inputs | | | 5 | pF | 1 |
| | C _{OUT} | Output pin capacitance | | | 6 | pF | 1 |
| | C _{INX} | X1 & X2 pins | | | 5 | pF | 1 |
| Clk Stabilization ^{1,2} | T _{STAB} | From VDD Power-Up or de-assertion of PD# to 1st clock. | | | 1.8 | ms | 1,2 |
| Modulation Frequency | | Triangular Modulation | 30 | | 33 | kHz | 1 |

¹Guaranteed by design, not 100% tested in production.

²See timing diagrams for timing requirements.

³Input frequency should be measured at the REF output pin and tuned to ideal 14.31818MHz to meet ppm frequency accuracy on PLL outputs.

Electrical Characteristics - CPU & SRC 0.7V Current Mode Differential Pair

$T_A = 0 - 70^\circ\text{C}$; $V_{DD} = 3.3\text{V} \pm 5\%$; $C_L = 2\text{pF}$

| PARAMETER | SYMBOL | CONDITIONS | MIN | TYP | MAX | UNITS | NOTES |
|---------------------------------|---------------|--|------|-----|------|----------|-------|
| Current Source Output Impedance | Z_o^1 | $V_O = V_x$ | 3000 | | | Ω | 1 |
| Voltage High | VHigh | Statistical measurement on single ended signal using oscilloscope math function. | 660 | | 850 | mV | 1 |
| Voltage Low | VLow | | -150 | | 150 | | 1 |
| Max Voltage | Vovs | Measurement on single ended signal using absolute value. | | | 1150 | mV | 1 |
| Min Voltage | Vuds | | -300 | | | | 1 |
| Crossing Voltage (abs) | Vcross(abs) | | 250 | | 550 | mV | 1 |
| Crossing Voltage (var) | d-Vcross | Variation of crossing over all edges | | | 140 | mV | 1 |
| Long Accuracy | ppm | see Tperiod min-max values | -300 | | 300 | ppm | 1,2 |
| Rise Time | t_r | $V_{OL} = 0.175\text{V}$, $V_{OH} = 0.525\text{V}$ | 175 | | 700 | ps | 1 |
| Fall Time | t_f | $V_{OH} = 0.525\text{V}$, $V_{OL} = 0.175\text{V}$ | 175 | | 700 | ps | 1 |
| Rise Time Variation | d- t_r | | | | 125 | ps | 1 |
| Fall Time Variation | d- t_f | | | | 125 | ps | 1 |
| Duty Cycle | d_{t3} | Measurement from differential waveform | 45 | | 55 | % | 1 |
| Skew | t_{sk3} | $V_T = 50\%$ | | | 100 | ps | 1 |
| Jitter, Cycle to cycle | $t_{jyc-cyc}$ | Measurement from differential waveform | | | 125 | ps | 1 |

¹Guaranteed by design, not 100% tested in production.

²All Long Term Accuracy and Clock Period specifications are guaranteed with the assumption that Ref output is at 14.31818MHz

Electrical Characteristics - 3V66

$T_A = 0 - 70^\circ\text{C}$; $V_{DD} = 3.3\text{V} \pm 5\%$; $C_L = 10\text{-}30\text{ pF}$ (unless otherwise specified)

| PARAMETER | SYMBOL | CONDITIONS | MIN | TYP | MAX | UNITS | Notes |
|---------------------|---------------|---|------|-----|------|-------|-------|
| Long Accuracy | ppm | see Tperiod min-max values | -300 | | 300 | ppm | 1,2 |
| Output High Voltage | V_{OH} | $I_{OH} = -1\text{ mA}$ | 2.4 | | | V | |
| Output Low Voltage | V_{OL} | $I_{OL} = 1\text{ mA}$ | | | 0.55 | V | |
| Output High Current | I_{OH} | $V_{OH@MIN} = 1.0\text{ V}$ | -33 | | | mA | |
| | | $V_{OH@MAX} = 3.135\text{ V}$ | | | -33 | mA | |
| Output Low Current | I_{OL} | $V_{OL@MIN} = 1.95\text{ V}$ | 30 | | | mA | |
| | | $V_{OL@MAX} = 0.4\text{ V}$ | | | 38 | mA | |
| Edge Rate | | Rising edge rate | 1 | | 4 | V/ns | 1 |
| Edge Rate | | Falling edge rate | 1 | | 4 | V/ns | 1 |
| Rise Time | t_{r1} | $V_{OL} = 0.4\text{ V}$, $V_{OH} = 2.4\text{ V}$ | 0.5 | | 2 | ns | 1 |
| Fall Time | t_{f1} | $V_{OH} = 2.4\text{ V}$, $V_{OL} = 0.4\text{ V}$ | 0.5 | | 2 | ns | 1 |
| Duty Cycle | d_{t1} | $V_T = 1.5\text{ V}$ | 45 | | 55 | % | 1 |
| Skew | t_{sk1} | $V_T = 1.5\text{ V}$ | | | 250 | ps | 1 |
| Jitter | $t_{jyc-cyc}$ | $V_T = 1.5\text{ V}$ 3V66 | | | 250 | ps | 1 |

¹Guaranteed by design, not 100% tested in production.

²All Long Term Accuracy and Clock Period specifications are guaranteed with the assumption that Ref output is at 14.31818MHz

Electrical Characteristics - 48MHz DOT Clock (24_48MHz & 48MHz_1)

$T_A = 0 - 70^\circ\text{C}$; $V_{DD} = 3.3\text{V} \pm 5\%$; $C_L = 5-10\text{ pF}$ (unless otherwise specified)

| PARAMETER | SYMBOL | CONDITIONS | MIN | TYP | MAX | UNITS | Notes |
|---------------------|-----------|---|------|-----|------|-------|-------|
| Long Accuracy | ppm | see Tperiod min-max values | -200 | | 200 | ppm | 1,2 |
| Output High Voltage | V_{OH} | $I_{OH} = -1\text{ mA}$ | 2.4 | | | V | |
| Output Low Voltage | V_{OL} | $I_{OL} = 1\text{ mA}$ | | | 0.55 | V | |
| Output High Current | I_{OH} | $V_{OH@MIN} = 1.0\text{ V}$ | -33 | | | mA | |
| | | $V_{OH@MAX} = 3.135\text{ V}$ | | | -33 | mA | |
| Output Low Current | I_{OL} | $V_{OL@MIN} = 1.95\text{ V}$ | 30 | | | mA | |
| | | $V_{OL@MAX} = 0.4\text{ V}$ | | | 38 | mA | |
| Edge Rate | | Rising edge rate | 2 | | 4 | V/ns | 1 |
| Edge Rate | | Falling edge rate | 2 | | 4 | V/ns | 1 |
| Rise Time | t_{r1} | $V_{OL} = 0.4\text{ V}, V_{OH} = 2.4\text{ V}$ | 0.5 | | 1 | ns | 1 |
| Fall Time | t_{f1} | $V_{OH} = 2.4\text{ V}, V_{OL} = 0.4\text{ V}$ | 0.5 | | 1 | ns | 1 |
| Duty Cycle | d_{t1} | $V_T = 1.5\text{ V}$ | 45 | | 55 | % | 1 |
| Skew | t_{sk1} | $V_T = 1.5\text{ V}$ | | | 1 | ns | 1 |
| Long Term Jitter | | 125us period jitter (8kHz frequency modulation amplitude) | | | 2 | ns | 1 |

¹Guaranteed by design, not 100% tested in production.

²All Long Term Accuracy and Clock Period specifications are guaranteed with the assumption that Ref output is at 14.31818MHz

Electrical Characteristics - PCICLK

$T_A = 0 - 70^\circ\text{C}$; $V_{DD} = 3.3\text{V} \pm 5\%$; $C_L = 10-30\text{ pF}$ (unless otherwise specified)

| PARAMETER | SYMBOL | CONDITIONS | MIN | TYP | MAX | UNITS | Notes |
|---------------------|---------------|--|------|-----|------|-------|-------|
| Long Accuracy | ppm | see Tperiod min-max values | -300 | | 300 | ppm | 1,2 |
| Output High Voltage | V_{OH} | $I_{OH} = -1\text{ mA}$ | 2.4 | | | V | |
| Output Low Voltage | V_{OL} | $I_{OL} = 1\text{ mA}$ | | | 0.55 | V | |
| Output High Current | I_{OH} | $V_{OH@MIN} = 1.0\text{ V}$ | -33 | | | mA | |
| | | $V_{OH@MAX} = 3.135\text{ V}$ | | | -33 | mA | |
| Output Low Current | I_{OL} | $V_{OL@MIN} = 1.95\text{ V}$ | 30 | | | mA | |
| | | $V_{OL@MAX} = 0.4\text{ V}$ | | | 38 | mA | |
| Edge Rate | | Rising edge rate | 1 | | 4 | V/ns | 1 |
| Edge Rate | | Falling edge rate | 1 | | 4 | V/ns | 1 |
| Rise Time | t_{r1} | $V_{OL} = 0.4\text{ V}, V_{OH} = 2.4\text{ V}$ | 0.5 | | 2 | ns | 1 |
| Fall Time | t_{f1} | $V_{OH} = 2.4\text{ V}, V_{OL} = 0.4\text{ V}$ | 0.5 | | 2 | ns | 1 |
| Duty Cycle | d_{t1} | $V_T = 1.5\text{ V}$ | 45 | | 55 | % | 1 |
| Skew | t_{sk1} | $V_T = 1.5\text{ V}$ | | | 500 | ps | 1 |
| Jitter | $t_{jyc-cyc}$ | $V_T = 1.5\text{ V}$ 3V66 | | | 250 | ps | 1 |

¹Guaranteed by design, not 100% tested in production.

²All Long Term Accuracy and Clock Period specifications are guaranteed with the assumption that Ref output is at 14.31818MHz

Electrical Characteristics - 48MHz, 24MHz

$T_A = 0 - 70^\circ\text{C}$; $V_{DD} = 3.3\text{V} \pm 5\%$; $C_L = 10\text{-}20\text{ pF}$ (unless otherwise specified)

| PARAMETER | SYMBOL | CONDITIONS | MIN | TYP | MAX | UNITS | Notes |
|---------------------|-----------|---|------|-----|------|-------|-------|
| Long Accuracy | ppm | see Tperiod min-max values | -200 | | 200 | ppm | 1,2 |
| Output High Voltage | V_{OH} | $I_{OH} = -1\text{ mA}$ | 2.4 | | | V | |
| Output Low Voltage | V_{OL} | $I_{OL} = 1\text{ mA}$ | | | 0.55 | V | |
| Output High Current | I_{OH} | $V_{OH@MIN} = 1.0\text{ V}$ | -33 | | | mA | |
| | | $V_{OH@MAX} = 3.135\text{ V}$ | | | -33 | mA | |
| Output Low Current | I_{OL} | $V_{OL@MIN} = 1.95\text{ V}$ | 30 | | | mA | |
| | | $V_{OL@MAX} = 0.4\text{ V}$ | | | 38 | mA | |
| Edge Rate | | Rising edge rate | 1 | | 2 | V/ns | 1 |
| Edge Rate | | Falling edge rate | 1 | | 2 | V/ns | 1 |
| Rise Time | t_{r1} | $V_{OL} = 0.4\text{ V}$, $V_{OH} = 2.4\text{ V}$ | 1 | | 2 | ns | 1 |
| Fall Time | t_{f1} | $V_{OH} = 2.4\text{ V}$, $V_{OL} = 0.4\text{ V}$ | 1 | | 2 | ns | 1 |
| Duty Cycle | d_{t1} | $V_T = 1.5\text{ V}$ | 45 | | 55 | % | 1 |
| Skew | t_{sk1} | $V_T = 1.5\text{ V}$ | | | 1 | ns | 1 |
| Long Term Jitter | | 125us period jitter (8kHz frequency modulation amplitude) | | | 6 | ns | 1 |

¹Guaranteed by design, not 100% tested in production.

²All Long Term Accuracy and Clock Period specifications are guaranteed with the assumption that Ref output is at 14.31818MHz

Electrical Characteristics - REF-14.318MHz

$T_A = 0 - 70^\circ\text{C}$; $V_{DD} = 3.3\text{V} \pm 5\%$; $C_L = 10\text{-}20\text{ pF}$ (unless otherwise specified)

| PARAMETER | SYMBOL | CONDITIONS | MIN | TYP | MAX | UNITS | Notes |
|---------------------|-----------------|---|------|-----|------|-------|-------|
| Long Accuracy | ppm | see Tperiod min-max values | -300 | | 300 | ppm | 1 |
| Output High Voltage | V_{OH}^1 | $I_{OH} = -1\text{ mA}$ | 2.4 | | | V | |
| Output Low Voltage | V_{OL}^1 | $I_{OL} = 1\text{ mA}$ | | | 0.4 | V | |
| Output High Current | I_{OH}^1 | $V_{OH@MIN} = 1.0\text{ V}$, $V_{OH@MAX} = 3.135\text{ V}$ | -29 | | -23 | mA | |
| Output Low Current | I_{OL}^1 | $V_{OL@MIN} = 1.95\text{ V}$, $V_{OL@MAX} = 0.4\text{ V}$ | 29 | | 27 | mA | |
| Rise Time | t_{r1}^1 | $V_{OL} = 0.4\text{ V}$, $V_{OH} = 2.4\text{ V}$ | 1 | | 2 | ns | 1 |
| Fall Time | t_{f1}^1 | $V_{OH} = 2.4\text{ V}$, $V_{OL} = 0.4\text{ V}$ | 1 | | 2 | ns | 1 |
| Skew | t_{sk1}^1 | $V_T = 1.5\text{ V}$ | | | 500 | ps | 1 |
| Duty Cycle | d_{t1}^1 | $V_T = 1.5\text{ V}$ | 45 | | 55 | % | 1 |
| Jitter | $t_{jyc-cyc}^1$ | $V_T = 1.5\text{ V}$ | | | 1000 | ps | 1 |

¹Guaranteed by design, not 100% tested in production.

Shared Pin Operation - Input/Output Pins

The I/O pins designated by (input/output) serve as dual signal functions to the device. During initial power-up, they act as input pins. The logic level (voltage) that is present on these pins at this time is read and stored into a 5-bit internal data latch. At the end of Power-On reset, (see AC characteristics for timing values), the device changes the mode of operations for these pins to an output function. In this mode the pins produce the specified buffered clocks to external loads.

To program (load) the internal configuration register for these pins, a resistor is connected to either the VDD (logic 1) power supply or the GND (logic 0) voltage potential. A 10 Kiloohm (10K) resistor is used to provide both the solid CMOS programming voltage needed during the power-up programming period and to provide an insignificant load on the output clock during the subsequent operating period.

Figure 1 shows a means of implementing this function when a switch or 2 pin header is used. With no jumper is installed the pin will be pulled high. With the jumper in place the pin will be pulled low. If programmability is not necessary, than only a single resistor is necessary. The programming resistors should be located close to the series termination resistor to minimize the current loop area. It is more important to locate the series termination resistor close to the driver than the programming resistor.

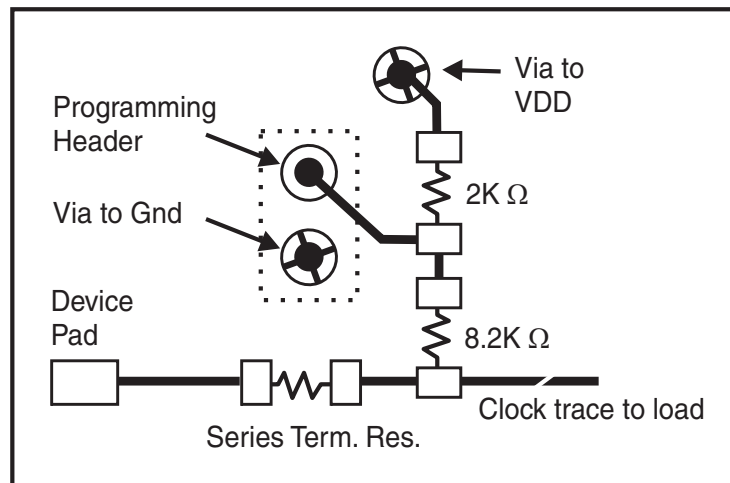
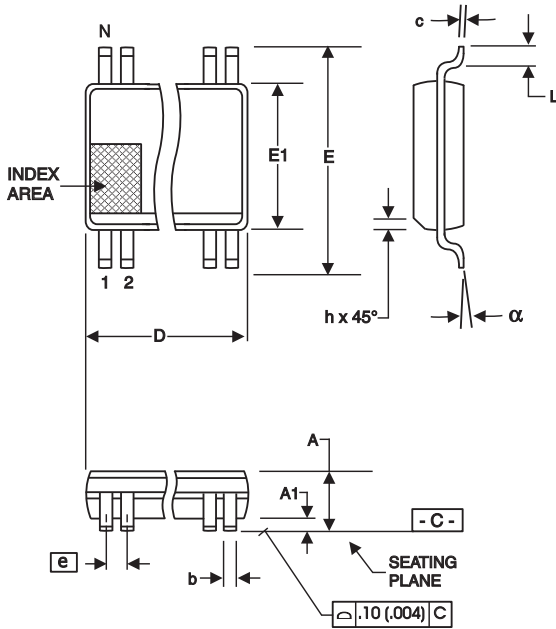

Fig. 1



| SYMBOL | In Millimeters COMMON DIMENSIONS | | In Inches COMMON DIMENSIONS | |
|--------|-------------------------------------|-------|--------------------------------|-------|
| | MIN | MAX | MIN | MAX |
| A | 2.41 | 2.80 | .095 | .110 |
| A1 | 0.20 | 0.40 | .008 | .016 |
| b | 0.20 | 0.34 | .008 | .0135 |
| c | 0.13 | 0.25 | .005 | .010 |
| D | SEE VARIATIONS | | SEE VARIATIONS | |
| E | 10.03 | 10.68 | .395 | .420 |
| E1 | 7.40 | 7.60 | .291 | .299 |
| e | 0.635 BASIC | | 0.025 BASIC | |
| h | 0.38 | 0.64 | .015 | .025 |
| L | 0.50 | 1.02 | .020 | .040 |
| N | SEE VARIATIONS | | SEE VARIATIONS | |
| alpha | 0° | 8° | 0° | 8° |

VARIATIONS

| N | D mm. | | D (inch) | |
|----|-------|-------|----------|------|
| | MIN | MAX | MIN | MAX |
| 48 | 15.75 | 16.00 | .620 | .630 |

Reference Doc.: JEDEC Publication 95, MO-118

10-0034

Ordering Information

952926yFLFT

Example:

XXXX y F LF-T

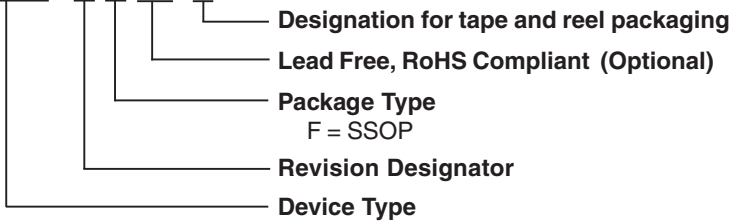

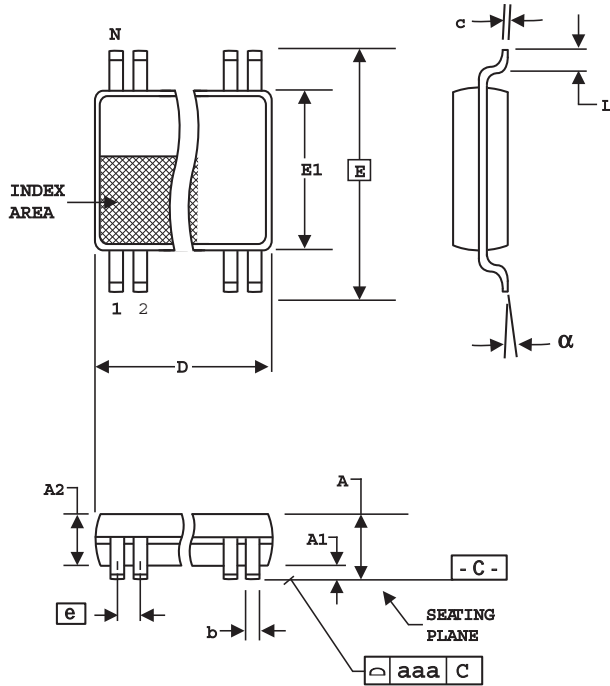

6.10 mm. Body, 0.50 mm. Pitch TSSOP
(240 mil) (20 mil)

| SYMBOL | In Millimeters | | In Inches | |
|--------|-------------------|------|-------------------|------|
| | COMMON DIMENSIONS | | COMMON DIMENSIONS | |
| | MIN | MAX | MIN | MAX |
| A | -- | 1.20 | -- | .047 |
| A1 | 0.05 | 0.15 | .002 | .006 |
| A2 | 0.80 | 1.05 | .032 | .041 |
| b | 0.17 | 0.27 | .007 | .011 |
| c | 0.09 | 0.20 | .0035 | .008 |
| D | SEE VARIATIONS | | SEE VARIATIONS | |
| E | 8.10 BASIC | | 0.319 BASIC | |
| E1 | 6.00 | 6.20 | .236 | .244 |
| e | 0.50 BASIC | | 0.020 BASIC | |
| L | 0.45 | 0.75 | .018 | .030 |
| N | SEE VARIATIONS | | SEE VARIATIONS | |
| α | 0° | 8° | 0° | 8° |
| aaa | -- | 0.10 | -- | .004 |

VARIATIONS

| N | D mm. | | D (inch) | |
|----|-------|-------|----------|------|
| | MIN | MAX | MIN | MAX |
| 48 | 12.40 | 12.60 | .488 | .496 |

Reference Doc.: JEDEC Publication 95, M O-153

10-0039

Ordering Information

952926yGLFT

Example:

XXXX y G LF-T

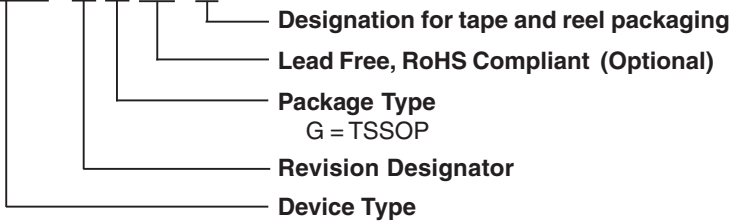

Компания «Океан Электроники» предлагает заключение долгосрочных отношений при поставках импортных электронных компонентов на взаимовыгодных условиях!

Наши преимущества:

- Поставка оригинальных импортных электронных компонентов напрямую с производств Америки, Европы и Азии, а так же с крупнейших складов мира;
- Широкая линейка поставок активных и пассивных импортных электронных компонентов (более 30 млн. наименований);
- Поставка сложных, дефицитных, либо снятых с производства позиций;
- Оперативные сроки поставки под заказ (от 5 рабочих дней);
- Экспресс доставка в любую точку России;
- Помощь Конструкторского Отдела и консультации квалифицированных инженеров;
- Техническая поддержка проекта, помощь в подборе аналогов, поставка прототипов;
- Поставка электронных компонентов под контролем ВП;
- Система менеджмента качества сертифицирована по Международному стандарту ISO 9001;
- При необходимости вся продукция военного и аэрокосмического назначения проходит испытания и сертификацию в лаборатории (по согласованию с заказчиком);
- Поставка специализированных компонентов военного и аэрокосмического уровня качества (Xilinx, Altera, Analog Devices, Intersil, Interpoint, Microsemi, Actel, Aeroflex, Peregrine, VPT, Syfer, Eurofarad, Texas Instruments, MS Kennedy, Miteq, Cobham, E2V, MA-COM, Hittite, Mini-Circuits, General Dynamics и др.);

Компания «Океан Электроники» является официальным дистрибьютором и эксклюзивным представителем в России одного из крупнейших производителей разъемов военного и аэрокосмического назначения «JONHON», а так же официальным дистрибьютором и эксклюзивным представителем в России производителя высокотехнологичных и надежных решений для передачи СВЧ сигналов «FORSTAR».



JONHON

«JONHON» (основан в 1970 г.)

Разъемы специального, военного и аэрокосмического назначения:

(Применяются в военной, авиационной, аэрокосмической, морской, железнодорожной, горно- и нефтедобывающей отраслях промышленности)

«FORSTAR» (основан в 1998 г.)

ВЧ соединители, коаксиальные кабели, кабельные сборки и микроволновые компоненты:

(Применяются в телекоммуникациях гражданского и специального назначения, в средствах связи, РЛС, а так же военной, авиационной и аэрокосмической отраслях промышленности).



Телефон: 8 (812) 309-75-97 (многоканальный)

Факс: 8 (812) 320-03-32

Электронная почта: ocean@oceanchips.ru

Web: <http://oceanchips.ru/>

Адрес: 198099, г. Санкт-Петербург, ул. Калинина, д. 2, корп. 4, лит. А