

Description

The 9DBV0241 is a member of IDT's 1.8V Very-Low-Power (VLP) PCIe family. The device has 2 output enables for clock management.

Recommended Application

1.8V PCIe Gen1/2/3 Zero-Delay/Fan-out Buffer (ZDB/FOB)

Output Features

- 2 - 1-200MHz Low-Power (LP) HCSL DIF pairs w/ $Z_o=100\Omega$

Key Specifications

- DIF cycle-to-cycle jitter <50ps
- DIF output-to-output skew <50ps
- DIF *additive* phase jitter is <100fs rms for PCIe Gen3
- DIF *additive* phase jitter <300fs rms (12k-20MHz)

Features/Benefits

- LP-HCSL outputs with $Z_o=100\Omega$; saves 8 resistors compared to standard HCSL outputs
- 35mW typical power consumption in PLL mode; reduced thermal concerns
- Spread Spectrum (SS) compatible; allows use of SS for EMI reduction
- OE# pins; support DIF power management
- HCSL compatible differential input; can be driven by common clock sources
- SMBus-selectable features; optimize signal integrity to application
 - slew rate for each output
 - differential output amplitude
- Pin/software selectable PLL bandwidth and PLL Bypass; optimize PLL to application
- Outputs blocked until PLL is locked; clean system start-up
- Device contains default configuration; SMBus interface not required for device control
- 3.3V tolerant SMBus interface; works with legacy controllers
- Space saving 24-pin 4x4mm VFQFPN; minimal board space

Block Diagram

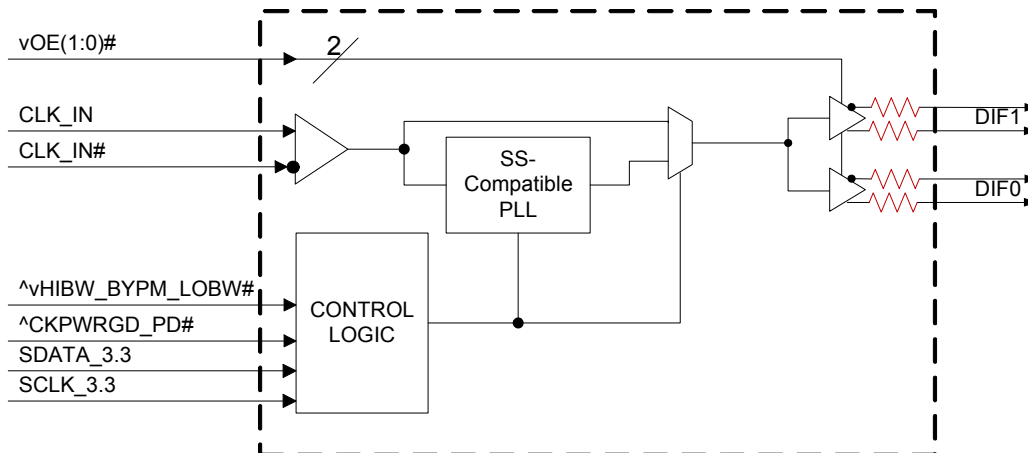

Pin Configuration

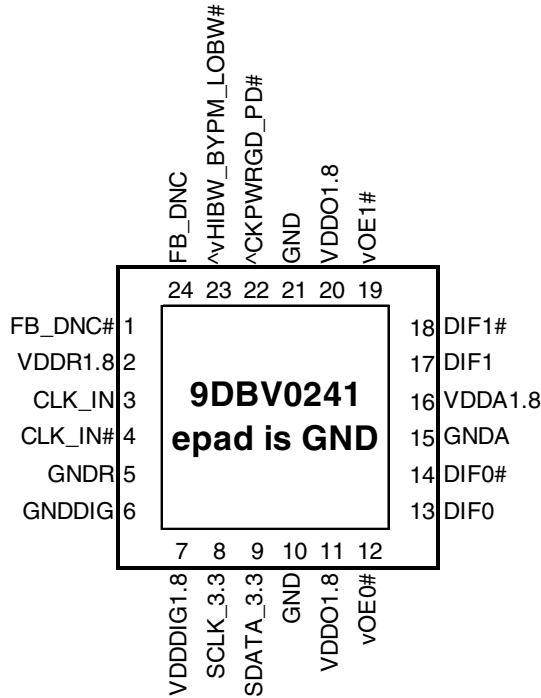

24-pin VFQFPN, 4x4 mm, 0.5mm pitch

- ^ prefix indicates internal 120KOhm pull up resistor
- ^v prefix indicates internal 120KOhm pull up AND pull down resistor (biased to VDD/2)
- v prefix indicates internal 120KOhm pull down resistor

Power Management Table

CKPWRGD_PD#	CLK_IN	SMBus OEx bit	OEx# Pin	DIFx		PLL
				True O/P	Comp. O/P	
0	X	X	X	Low	Low	Off
1	Running	0	X	Low	Low	On ¹
1	Running	1	0	Running	Running	On ¹
1	Running	1	1	Low	Low	On ¹

1. If Bypass mode is selected, the PLL will be off, and outputs will be running.

Power Connections

Pin Number		Description
VDD	GND	
2	5	Input receiver analog
7	6	Digital Power
11,20	10,21	DIF outputs
16	15	PLL Analog

PLL Operating Mode

HiBW_BypM_LoBW#	MODE	Byte1 [7:6] Readback	Byte1 [4:3] Control
0	PLL Lo BW	00	00
M	Bypass	01	01
1	PLL Hi BW	11	11

Frequency Select Table

FSEL Byte3 [4:3]	CLK_IN (MHz)	DIFx (MHz)
00 (Default)	100.00	CLK_IN
01	50.00	CLK_IN
10	125.00	CLK_IN
11	Reserved	Reserved

SMBus Address

Address	+ Read/Write bit
1101101	x

Pin Descriptions

Pin#	Pin Name	Type	Pin Description
1	FB_DNC#	DNC	Complement clock of differential feedback. The feedback output and feedback input are connected internally on this pin. Do not connect anything to this pin.
2	VDDR1.8	PWR	1.8V power for differential input clock (receiver). This VDD should be treated as an Analog power rail and filtered appropriately.
3	CLK_IN	IN	True Input for differential reference clock.
4	CLK_IN#	IN	Complementary Input for differential reference clock.
5	GNDR	GND	Analog Ground pin for the differential input (receiver)
6	GNDDIG	GND	Ground pin for digital circuitry
7	VDDDIG1.8	PWR	1.8V digital power (dirty power)
8	SCLK_3.3	IN	Clock pin of SMBus circuitry, 3.3V tolerant.
9	SDATA_3.3	I/O	Data pin for SMBus circuitry, 3.3V tolerant.
10	GND	GND	Ground pin.
11	VDDO1.8	PWR	Power supply for outputs, nominally 1.8V.
12	vOE0#	IN	Active low input for enabling DIF pair 0. This pin has an internal pull-down. 1 =disable outputs, 0 = enable outputs
13	DIF0	OUT	Differential true clock output
14	DIF0#	OUT	Differential Complementary clock output
15	GNDA	GND	Ground pin for the PLL core.
16	VDDA1.8	PWR	1.8V power for the PLL core.
17	DIF1	OUT	Differential true clock output
18	DIF1#	OUT	Differential Complementary clock output
19	vOE1#	IN	Active low input for enabling DIF pair 1. This pin has an internal pull-down. 1 =disable outputs, 0 = enable outputs
20	VDDO1.8	PWR	Power supply for outputs, nominally 1.8V.
21	GND	GND	Ground pin.
22	^CKPWRGD_PD#	IN	Input notifies device to sample latched inputs and start up on first high assertion. Low enters Power Down Mode, subsequent high assertions exit Power Down Mode. This pin has internal pull-up resistor.
23	^vHIBW_BYPM_LOBW#	LATCHED IN	Trilevel input to select High BW, Bypass or Low BW mode. This pin is biased to VDD/2 (Bypass mode) with internal pull up/pull down resistors. See PLL Operating Mode Table for Details.
24	FB_DNC	DNC	True clock of differential feedback. The feedback output and feedback input are connected internally on this pin. Do not connect anything to this pin.
25	epad	GND	GND

NOTE: DNC indicates Do Not Connect anything to this pin.

Test Loads

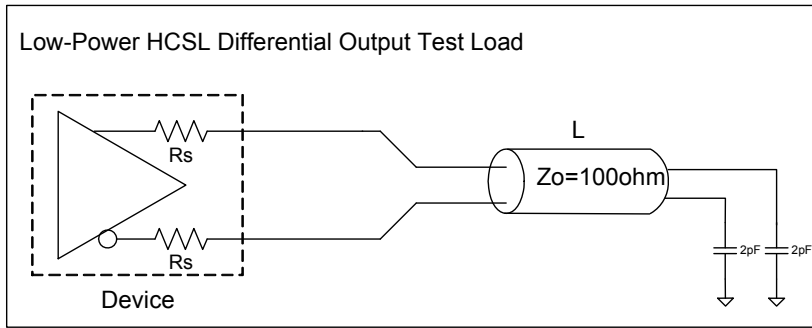

$L = 5$ inches

Alternate Terminations

The 9DBV family can easily drive LVPECL, LVDS, and CML logic. See ["AN-891 Driving LVPECL, LVDS, and CML Logic with IDT's "Universal" Low-Power HCSL Outputs"](#) for details.

Absolute Maximum Ratings

Stresses above the ratings listed below can cause permanent damage to the 9DBV0241. These ratings, which are standard values for IDT commercially rated parts, are stress ratings only. Functional operation of the device at these or any other conditions above those indicated in the operational sections of the specifications is not implied. Exposure to absolute maximum rating conditions for extended periods can affect product reliability. Electrical parameters are guaranteed only over the recommended operating temperature range.

PARAMETER	SYMBOL	CONDITIONS	MIN	TYP	MAX	UNITS	NOTES
1.8V Supply Voltage	VDDxx	Applies to all VDD pins	-0.5		2.5	V	1,2
Input Voltage	V _{IN}		-0.5		V _{DD} +0.5V	V	1, 3
Input High Voltage, SMBus	V _{IHSMB}	SMBus clock and data pins			3.6V	V	1
Storage Temperature	T _s		-65		150	°C	1
Junction Temperature	T _j				125	°C	1
Input ESD protection	ESD prot	Human Body Model	2000			V	1

¹Guaranteed by design and characterization, not 100% tested in production.

²Operation under these conditions is neither implied nor guaranteed.

³Not to exceed 2.5V.

Electrical Characteristics–Clock Input Parameters

T_A = T_{COM} or T_{IND}; Supply Voltage per VDD of normal operation conditions, See Test Loads for Loading Conditions

PARAMETER	SYMBOL	CONDITIONS	MIN	TYP	MAX	UNITS	NOTES
Input Common Mode Voltage - DIF_IN	V _{COM}	Common Mode Input Voltage	150		1000	mV	1
Input Swing - DIF_IN	V _{SWING}	Differential value	300		1450	mV	1
Input Slew Rate - DIF_IN	dv/dt	Measured differentially	0.4		8	V/ns	1,2
Input Leakage Current	I _{IN}	V _{IN} = V _{DD} , V _{IN} = GND	-5		5	uA	
Input Duty Cycle	d _{tin}	Measurement from differential waveform	45		55	%	1
Input Jitter - Cycle to Cycle	J _{DIFIN}	Differential Measurement	0		125	ps	1

¹ Guaranteed by design and characterization, not 100% tested in production.

²Slew rate measured through +/-75mV window centered around differential zero

Electrical Characteristics–Input/Supply/Common Parameters–Normal Operating Conditions

TA = T_{AMB}, Supply Voltages per normal operation conditions, See Test Loads for Loading Conditions

PARAMETER	SYMBOL	CONDITIONS	MIN	TYP	MAX	UNITS	NOTES
Supply Voltage	VDDx	Supply voltage for core and analog	1.7	1.8	1.9	V	
Ambient Operating Temperature	T _{AMB}	Commercial range	0	25	70	°C	
		Industrial range	-40	25	85	°C	
Input High Voltage	V _{IH}	Single-ended inputs, except SMBus	0.75 V _{DD}		V _{DD} + 0.3	V	
Input Mid Voltage	V _{IM}	Single-ended tri-level inputs ('_tri' suffix)	0.4 V _{DD}		0.6 V _{DD}	V	
Input Low Voltage	V _{IL}	Single-ended inputs, except SMBus	-0.3		0.25 V _{DD}	V	
Input Current	I _{IN}	Single-ended inputs, V _{IN} = GND, V _{IN} = VDD	-5		5	uA	
	I _{INP}	Single-ended inputs V _{IN} = 0 V; Inputs with internal pull-up resistors V _{IN} = VDD; Inputs with internal pull-down resistors	-200		200	uA	
Input Frequency	F _{ibyp}	Bypass mode	1		200	MHz	2
	F _{ipll}	100MHz PLL mode	60	100.00	140	MHz	2
	F _{ipll}	125MHz PLL mode	75	125.00	175	MHz	2
	F _{ipll}	50MHz PLL mode	30	50.00	65	MHz	2
Capacitance	C _{IN}	Logic Inputs, except DIF_IN	1.5		5	pF	1
	C _{INDIF_IN}	DIF_IN differential clock inputs	1.5		2.7	pF	1,5
	C _{OUT}	Output pin capacitance			6	pF	1
Clk Stabilization	T _{STAB}	From V _{DD} Power-Up and after input clock stabilization or de-assertion of PD# to 1st clock			1	ms	1,2
Input SS Modulation Frequency PCIe	f _{MODINPCIe}	Allowable Frequency for PCIe Applications (Triangular Modulation)	30		33	kHz	
Input SS Modulation Frequency non-PCIe	f _{MODIN}	Allowable Frequency for non-PCIe Applications (Triangular Modulation)	0		66	kHz	
OE# Latency	t _{LATOE#}	DIF start after OE# assertion DIF stop after OE# deassertion	1		3	clocks	1,3
Tdrive_PD#	t _{DRVPD}	DIF output enable after PD# de-assertion			300	us	1,3
Tfall	t _F	Fall time of single-ended control inputs			5	ns	2
Trise	t _R	Rise time of single-ended control inputs			5	ns	2
SMBus Input Low Voltage	V _{ILSMB}	V _{DDSMB} = 3.3V, see note 4 for V _{DDSMB} < 3.3V			0.6	V	
SMBus Input High Voltage	V _{IHSMB}	V _{DDSMB} = 3.3V, see note 5 for V _{DDSMB} < 3.3V	2.1		3.6	V	4
SMBus Output Low Voltage	V _{OLSMB}	@ I _{PULLUP}			0.4	V	
SMBus Sink Current	I _{PULLUP}	@ V _{OL}	4			mA	
Nominal Bus Voltage	V _{DDSMB}	Bus Voltage	1.7		3.6	V	
SCLK/SDATA Rise Time	t _{RSMB}	(Max V _{IL} - 0.15) to (Min V _{IH} + 0.15)			1000	ns	1
SCLK/SDATA Fall Time	t _{FSMB}	(Min V _{IH} + 0.15) to (Max V _{IL} - 0.15)			300	ns	1
SMBus Operating Frequency	f _{MAXSMB}	Maximum SMBus operating frequency			400	kHz	6

¹Guaranteed by design and characterization, not 100% tested in production.

²Control input must be monotonic from 20% to 80% of input swing.

³Time from deassertion until outputs are >200 mV

⁴ For V_{DDSMB} < 3.3V, V_{IHSMB} ≥ 0.8xV_{DDSMB}

⁵DIF_IN input

⁶The differential input clock must be running for the SMBus to be active

Electrical Characteristics–DIF 0.7V Low Power HCSL Outputs

TA = T_{AMB}, Supply Voltages per normal operation conditions, See Test Loads for Loading Conditions

PARAMETER	SYMBOL	CONDITIONS	MIN	TYP	MAX	UNITS	NOTES
Slew rate	dV/dt	Scope averaging on, fast setting	1.6	2.8	4	V/ns	1,2,3
	dV/dt	Scope averaging on, slow setting	1.1	2.0	3	V/ns	1,2,3
Slew rate matching	8dV/dt	Slew rate matching, Scope averaging on		7	20	%	1,2,4
Voltage High	V _{HIGH}	Statistical measurement on single-ended signal using oscilloscope math function. (Scope averaging on)	660	736	850	mV	7
Voltage Low	V _{LOW}		-150	32	150		7
Max Voltage	V _{max}	Measurement on single ended signal using absolute value. (Scope averaging off)		769	1150	mV	7
Min Voltage	V _{min}		-300	21			7
Crossing Voltage (abs)	V _{cross_abs}	Scope averaging off	250	391	550	mV	1,5
Crossing Voltage (var)	Δ-V _{cross}	Scope averaging off		13	140	mV	1,6

¹Guaranteed by design and characterization, not 100% tested in production.

² Measured from differential waveform

³ Slew rate is measured through the V_{swing} voltage range centered around differential 0V. This results in a +/-150mV window around differential 0V.

⁴ Matching applies to rising edge rate for Clock and falling edge rate for Clock#. It is measured using a +/-75mV window centered on the average cross point where Clock rising meets Clock# falling. The median cross point is used to calculate the voltage thresholds the oscilloscope is to use for the edge rate calculations.

⁵ V_{cross} is defined as voltage where Clock = Clock# measured on a component test board and only applies to the differential rising edge (i.e. Clock rising and Clock# falling).

⁶ The total variation of all V_{cross} measurements in any particular system. Note that this is a subset of V_{cross_min/max} (V_{cross} absolute) allowed. The intent is to limit V_{cross} induced modulation by setting Δ-V_{cross} to be smaller than V_{cross} absolute.

⁷ At default SMBus settings.

Electrical Characteristics–Current Consumption

TA = T_{AMB}, Supply Voltages per normal operation conditions, See Test Loads for Loading Conditions

PARAMETER	SYMBOL	CONDITIONS	MIN	TYP	MAX	UNITS	NOTES
Operating Supply Current	I _{DDA}	VDDA+VDDR, PLL Mode, @100MHz		4.4	6	mA	1
	I _{DD}	VDD, All outputs active @100MHz		14.2	18	mA	1
Powerdown Current	I _{DDAPD}	VDDA+VDDR, PLL Mode, @100MHz		0.01	1	mA	1, 2
	I _{DDPD}	VDD, Outputs Low/Low		0.9	1.4	mA	1, 2

¹ Guaranteed by design and characterization, not 100% tested in production.

² Input clock stopped.

Electrical Characteristics–Output Duty Cycle, Jitter, Skew and PLL Characteristics

TA = T_{AMB}, Supply Voltages per normal operation conditions, See Test Loads for Loading Conditions

PARAMETER	SYMBOL	CONDITIONS	MIN	TYP	MAX	UNITS	NOTES
PLL Bandwidth	BW	-3dB point in High BW Mode	2	2.7	4	MHz	1,5
		-3dB point in Low BW Mode	1	1.4	2	MHz	1,5
PLL Jitter Peaking	t _{JPEAK}	Peak Pass band Gain		1.05	2	dB	1
Duty Cycle	t _{DC}	Measured differentially, PLL Mode	45	50	55	%	1
Duty Cycle Distortion	t _{DCD}	Measured differentially, Bypass Mode @100MHz	-1	-0.1	1	%	1,3
Skew, Input to Output	t _{pdBYP}	Bypass Mode, V _T = 50%	2800	3623	4500	ps	1
	t _{pdPLL}	PLL Mode V _T = 50%	0	112	200	ps	1,4
Skew, Output to Output	t _{sk3}	V _T = 50%		33	50	ps	1,4
Jitter, Cycle to cycle	t _{jcy-cyc}	PLL mode		13	50	ps	1,2
		Additive Jitter in Bypass Mode		0.1	5	ps	1,2

¹ Guaranteed by design and characterization, not 100% tested in production.

² Measured from differential waveform

³ Duty cycle distortion is the difference in duty cycle between the output and the input clock when the device is operated in bypass mode.

⁴ All outputs at default slew rate

⁵ The MIN/TYP/MAX values of each BW setting track each other, i.e., Low BW MAX will never occur with Hi BW MIN.

Electrical Characteristics–Phase Jitter Parameters

TA = T_{AMB}, Supply Voltages per normal operation conditions, See Test Loads for Loading Conditions

PARAMETER	SYMBOL	CONDITIONS	MIN	TYP	MAX	INDUSTRY LIMIT	UNITS	Notes
Phase Jitter, PLL Mode	t _{jphPCleG1}	PCIe Gen 1		32	52	86	ps (p-p)	1,2,3,5
	t _{jphPCleG2}	PCIe Gen 2 Lo Band 10kHz < f < 1.5MHz		0.8	1.4	3	ps (rms)	1,2,3,5
		PCIe Gen 2 High Band 1.5MHz < f < Nyquist (50MHz)		2.4	2.5	3.1	ps (rms)	1,2,3,5
	t _{jphPCleG3}	PCIe Gen 3 (PLL BW of 2-4 or 2-5MHz, CDR = 10MHz)		0.5	0.6	1	ps (rms)	1,2,3,5
	t _{jphSGMII}	125MHz, 1.5MHz to 10MHz, -20dB/decade rollover < 1.5MHz, -40db/decade rolloff > 10MHz		1.9	2	NA	ps (rms)	1,6
Additive Phase Jitter, Bypass Mode	t _{jphPCleG1}	PCIe Gen 1		0.1	5	N/A	ps (p-p)	1,2,3,5
	t _{jphPCleG2}	PCIe Gen 2 Lo Band 10kHz < f < 1.5MHz		0.2	0.3	N/A	ps (rms)	1,2,3,4,5
		PCIe Gen 2 High Band 1.5MHz < f < Nyquist (50MHz)		0.00	0.1	N/A	ps (rms)	1,2,3,4
	t _{jphPCleG3}	PCIe Gen 3 (PLL BW of 2-4 or 2-5MHz, CDR = 10MHz)		0.00	0.1	N/A	ps (rms)	1,2,3,4
	t _{jphSGMII}	125MHz, 1.5MHz to 10MHz, -20dB/decade rollover < 1.5MHz, -40db/decade rolloff > 10MHz		165	200	N/A	ps (rms)	1,6
t _{jphSGMII}	125MHz, 12kHz to 20MHz, -20dB/decade rollover < 1.5MHz, -40db/decade rolloff > 10MHz		251	300	N/A	ps (rms)	1,6	

¹ Guaranteed by design and characterization, not 100% tested in production.

² See <http://www.pcisig.com> for complete specs

³ Sample size of at least 100K cycles. This figures extrapolates to 108ps pk-pk @ 1M cycles for a BER of 1-12.

⁴ For RMS figures, additive jitter is calculated by solving the following equation: Additive jitter = SQRT[(total jitter)² - (input jitter)²]

⁵ Driven by 9FG432 or equivalent

⁶ Rohde&Schartz SMA100

Additive Phase Jitter Plot: 125M (12kHz to 20MHz)

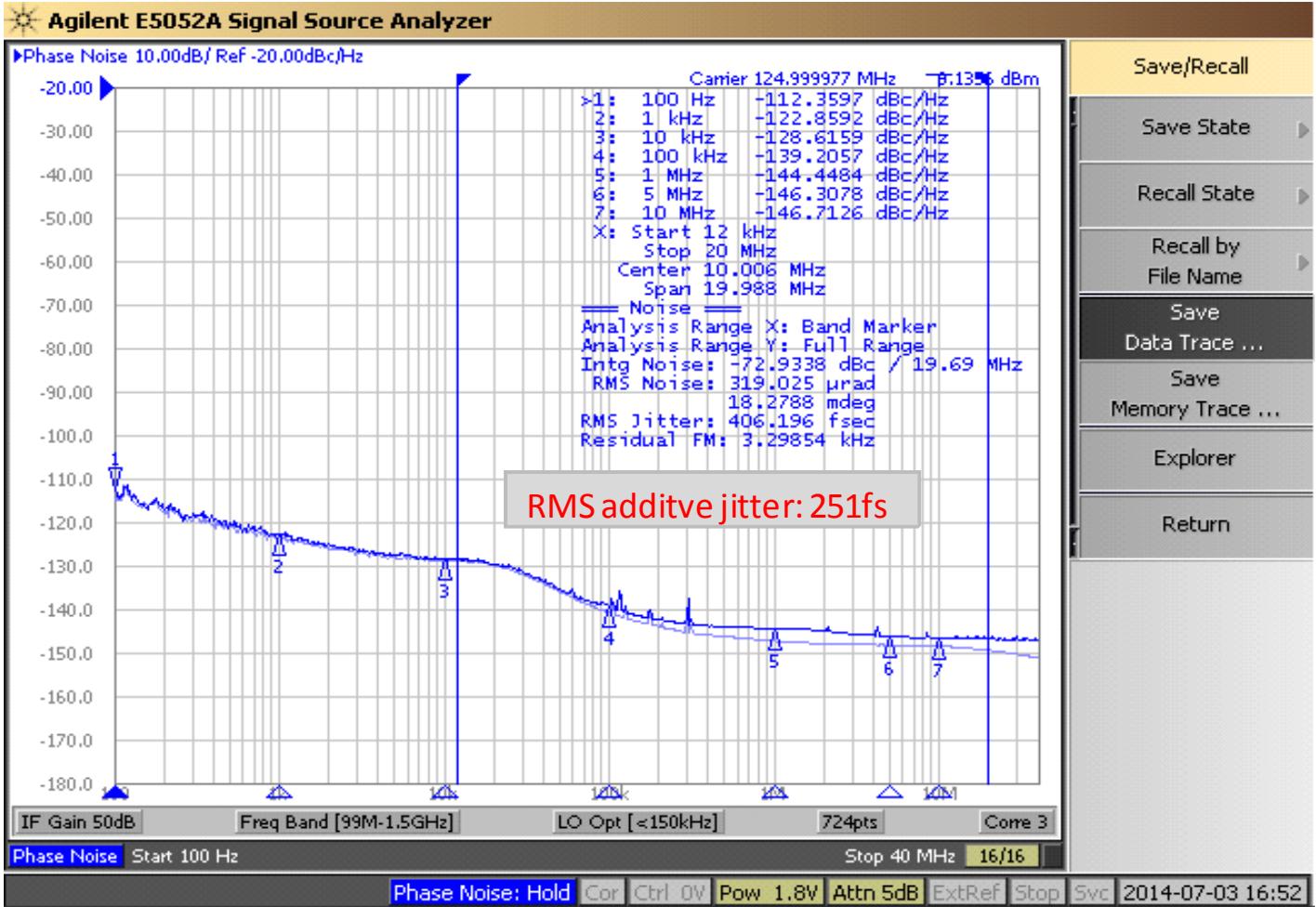

General SMBus Serial Interface Information

How to Write

- Controller (host) sends a start bit
- Controller (host) sends the write address
- IDT clock will **acknowledge**
- Controller (host) sends the beginning byte location = N
- IDT clock will **acknowledge**
- Controller (host) sends the byte count = X
- IDT clock will **acknowledge**
- Controller (host) starts sending Byte N through Byte N+X-1
- IDT clock will **acknowledge** each byte **one at a time**
- Controller (host) sends a Stop bit

Index Block Write Operation		
Controller (Host)		IDT (Slave/Receiver)
T	starT bit	
Slave Address		
WR	WRite	
Beginning Byte = N		ACK
		ACK
Data Byte Count = X		ACK
Beginning Byte N		ACK
		X Byte
O		
O		
O		
Byte N + X - 1		ACK
P	stoP bit	

Note: SMBus Address is 1101101x, where x is the read/write bit.

How to Read

- Controller (host) will send a start bit
- Controller (host) sends the write address
- IDT clock will **acknowledge**
- Controller (host) sends the beginning byte location = N
- IDT clock will **acknowledge**
- Controller (host) will send a separate start bit
- Controller (host) sends the read address
- IDT clock will **acknowledge**
- IDT clock will send the data byte count = X
- IDT clock sends Byte N+X-1
- IDT clock sends **Byte 0 through Byte X (if X_(H) was written to Byte 8)**
- Controller (host) will need to acknowledge each byte
- Controller (host) will send a not acknowledge bit
- Controller (host) will send a stop bit

Index Block Read Operation		
Controller (Host)		IDT (Slave/Receiver)
T	starT bit	
Slave Address		
WR	WRite	
Beginning Byte = N		ACK
		ACK
RT	Repeat starT	
Slave Address		
RD	ReaD	
		ACK
ACK		
ACK		
O		X Byte
O		
O		
O		
ACK		
ACK		
		Beginning Byte N
		O
		O
		O
		Byte N + X - 1
N	Not acknowledge	
P	stoP bit	

SMBus Table: Output Enable Register ¹

Byte 0	Name	Control Function	Type	0	1	Default
Bit 7	Reserved					1
Bit 6	Reserved					1
Bit 5	DIF OE1	Output Enable	RW	Low/Low	Enabled	1
Bit 4	Reserved					1
Bit 3	DIF OE0	Output Enable	RW	Low/Low	Enabled	1
Bit 2	Reserved					1
Bit 1	Reserved					1
Bit 0	Reserved					1

1. A low on these bits will override the OE# pin and force the differential output Low/Low

SMBus Table: PLL Operating Mode and Output Amplitude Control Register

Byte 1	Name	Control Function	Type	0	1	Default
Bit 7	PLLMODERB1	PLL Mode Readback Bit 1	R	See PLL Operating Mode Table		Latch
Bit 6	PLLMODERB0	PLL Mode Readback Bit 0	R			Latch
Bit 5	PLLMODE_SWCNTRL	Enable SW control of PLL Mode	RW	Values in B1[7:6] set PLL Mode	Values in B1[4:3] set PLL Mode	0
Bit 4	PLLMODE1	PLL Mode Control Bit 1	RW ¹	See PLL Operating Mode Table		0
Bit 3	PLLMODE0	PLL Mode Control Bit 0	RW ¹			0
Bit 2	Reserved					1
Bit 1	AMPLITUDE 1	Controls Output Amplitude	RW	00 = 0.6V	01 = 0.7V	1
Bit 0	AMPLITUDE 0		RW	10 = 0.8V	11 = 0.9V	0

1. B1[5] must be set to a 1 for these bits to have any effect on the part.

SMBus Table: DIF Slew Rate Control Register

Byte 2	Name	Control Function	Type	0	1	Default
Bit 7	Reserved					1
Bit 6	Reserved					1
Bit 5	SLEWRATESEL DIF1	Slew Rate Selection	RW	Slow setting	Fast setting	1
Bit 4	Reserved					1
Bit 3	SLEWRATESEL DIF0	Slew Rate Selection	RW	Slow setting	Fast setting	1
Bit 2	Reserved					1
Bit 1	Reserved					1
Bit 0	Reserved					1

SMBus Table: Frequency Select Control Register

Byte 3	Name	Control Function	Type	0	1	Default
Bit 7	Reserved					1
Bit 6	Reserved					1
Bit 5	FREQ_SEL_EN	Enable SW selection of frequency	RW	SW frequency change disabled	SW frequency change enabled	0
Bit 4	FSEL1	Freq. Select Bit 1	RW ¹	See Frequency Select Table		0
Bit 3	FSEL0	Freq. Select Bit 0	RW ¹			0
Bit 2	Reserved					1
Bit 1	Reserved					1
Bit 0	SLEWRATESEL FB	Adjust Slew Rate of FB	RW	Slow setting	Fast setting	1

1. B3[5] must be set to a 1 for these bits to have any effect on the part.

Byte 4 is Reserved and reads back 'hFF'

SMBus Table: Revision and Vendor ID Register

Byte 5	Name	Control Function	Type	0	1	Default
Bit 7	RID3	Revision ID	R	A rev = 0000		0
Bit 6	RID2		R			0
Bit 5	RID1		R			0
Bit 4	RID0		R			0
Bit 3	VID3	VENDOR ID	R	0001 = IDT		0
Bit 2	VID2		R			0
Bit 1	VID1		R			0
Bit 0	VID0		R			1

SMBus Table: Device Type/Device ID

Byte 6	Name	Control Function	Type	0	1	Default
Bit 7	Device Type1	Device Type	R	00 = FGx, 01 = DBx, 10 = DMx, 11= Reserved		0
Bit 6	Device Type0		R			1
Bit 5	Device ID5	Device ID	R	000100 binary or 02 hex		0
Bit 4	Device ID4		R			0
Bit 3	Device ID3		R			0
Bit 2	Device ID2		R			0
Bit 1	Device ID1		R			1
Bit 0	Device ID0		R			0

SMBus Table: Byte Count Register

Byte 7	Name	Control Function	Type	0	1	Default
Bit 7		Reserved				0
Bit 6		Reserved				0
Bit 5		Reserved				0
Bit 4	BC4	Byte Count Programming	RW	Writing to this register will configure how many bytes will be read back, default is = 8 bytes.		0
Bit 3	BC3		RW			1
Bit 2	BC2		RW			0
Bit 1	BC1		RW			0
Bit 0	BC0		RW			0

Marking Diagrams

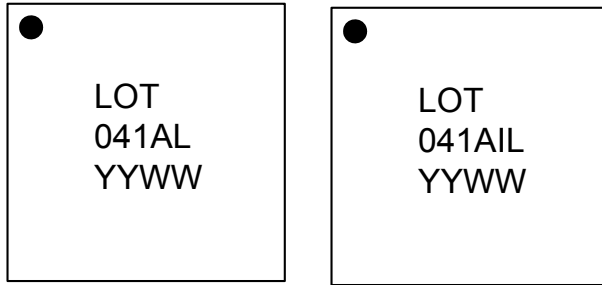

Notes:

1. 'LOT' is the lot number.
2. 'YYWW' is the last two digits of the year and week that the part was assembled.
3. 'L' denotes RoHS compliant package.
4. 'I' denotes industrial temperature grade.

Thermal Characteristics

PARAMETER	SYMBOL	CONDITIONS	PKG	TYP VALUE	UNITS	NOTES
Thermal Resistance	θ_{JC}	Junction to Case	NLG20 NLG24	62	°C/W	1
	θ_{Jb}	Junction to Base		5.4	°C/W	1
	θ_{JA0}	Junction to Air, still air		50	°C/W	1
	θ_{JA1}	Junction to Air, 1 m/s air flow		43	°C/W	1
	θ_{JA3}	Junction to Air, 3 m/s air flow		39	°C/W	1
	θ_{JA5}	Junction to Air, 5 m/s air flow		38	°C/W	1

¹ePad soldered to board

Package Outline and Dimensions (NLG24)

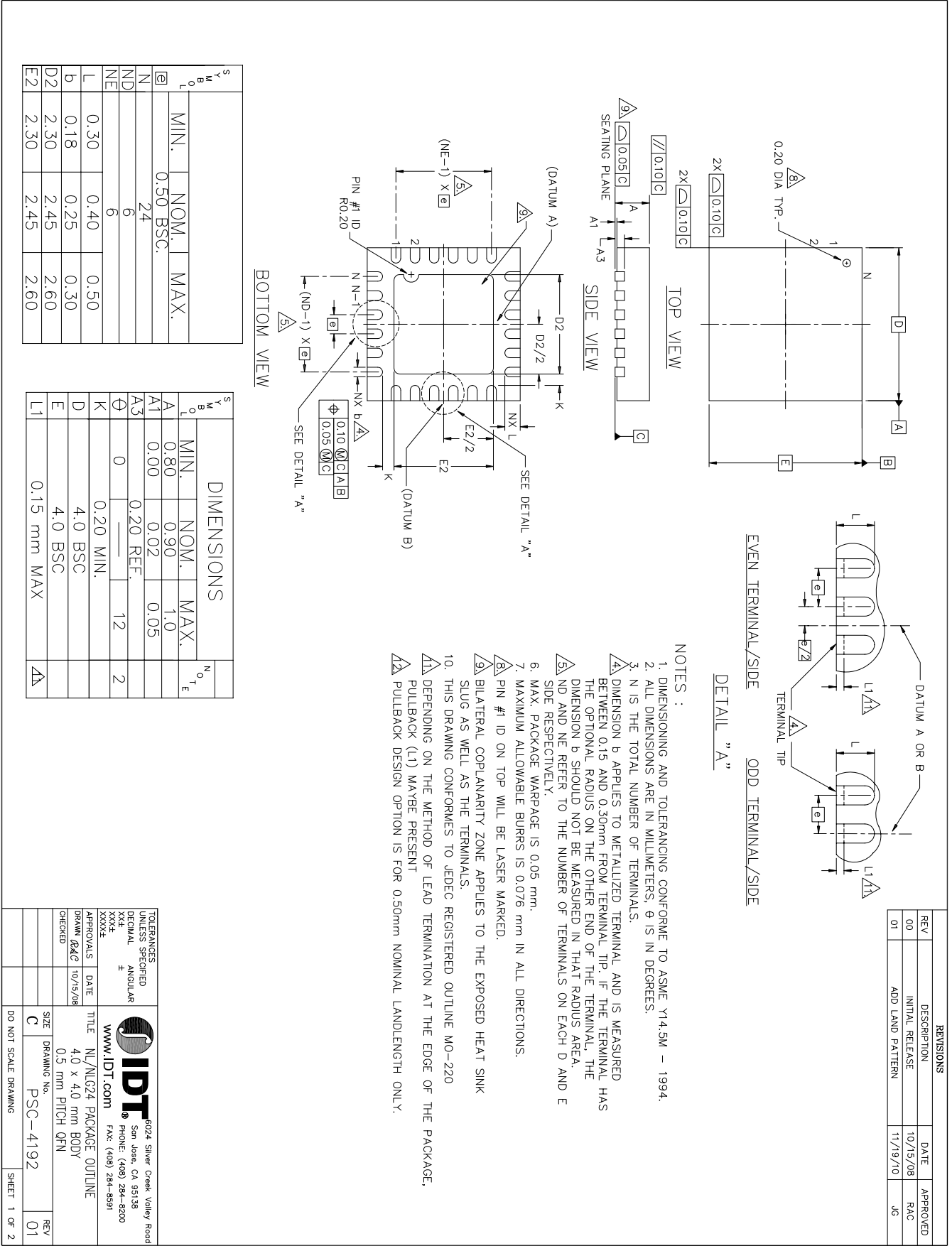

S	Y	M	B	O
MIN.	NOM.	MAX.		
0.50 BSC.	24			
6				
0.40	0.25	0.30		
2.30	2.45	2.60		
2.30	2.45	2.60		

S	Y	M	B	O	N	O	T	E
MIN.	NOM.	MAX.						
0.80	0.90	1.0						
0.00	0.02	0.05						
0.20 REF.								
0								
0.20 MIN.								
4.0 BSC								
4.0 BSC								
0.15 MAX								

- NOTES :
1. DIMENSIONING AND TOLERANCING CONFORM TO ASME Y14.5M - 1994.
 2. ALL DIMENSIONS ARE IN MILLIMETERS, θ IS IN DEGREES.
 3. N IS THE TOTAL NUMBER OF TERMINALS.
 4. DIMENSION b APPLIES TO METALLIZED TERMINAL AND IS MEASURED BETWEEN 0.15 AND 0.30mm FROM TERMINAL TIP. IF THE TERMINAL HAS THE OPTIONAL RADIUS ON THE OTHER END OF THE TERMINAL, THE DIMENSION b SHOULD NOT BE MEASURED IN THAT RADIUS AREA. ND AND NE REFER TO THE NUMBER OF TERMINALS ON EACH D AND E SIDE RESPECTIVELY.
 5. MAX. PACKAGE WARRPAGE IS 0.05 mm.
 6. MAXIMUM ALLOWABLE BURRS IS 0.076 mm IN ALL DIRECTIONS.
 7. PIN #1 ID ON TOP WILL BE LASER MARKED.
 8. BILATERAL COPLANARITY ZONE APPLIES TO THE EXPOSED HEAT SINK SLUG AS WELL AS THE TERMINALS.
 9. THIS DRAWING CONFORMS TO JEDEC REGISTERED OUTLINE MO-220 DEPENDING ON THE METHOD OF LEAD TERMINATION AT THE EDGE OF THE PACKAGE. PULLBACK (L1) MAYBE PRESENT
 10. PULLBACK DESIGN OPTION IS FOR 0.50mm NOMINAL LANDLENGTH ONLY.

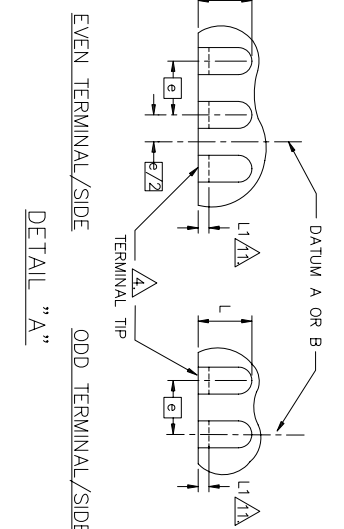

REV	DESCRIPTION	DATE	APPROVED
00	INITIAL RELEASE	10/15/08	FAC
01	ADD LAND PATTERN	11/19/10	JG

TOLERANCES UNLESS SPECIFIED
 DECIMAL ±
 ANGULAR ±

APPROVALS: DATE: 10/19/08
 DRAWN: GAG
 CHECKED:

SIZE: C
 DRAWING NO.: PSC-4192
 DO NOT SCALE DRAWING

SHEET 1 OF 2

6024 Silver Creek Valley Road
 San Jose, CA 95138
 PHONE: (408) 284-8200
 FAX: (408) 284-8991
 www.IDT.com

TITLE: NL/NLG24 PACKAGE OUTLINE
 BODY: 4.0 x 4.0 mm
 PITCH: 0.5 mm

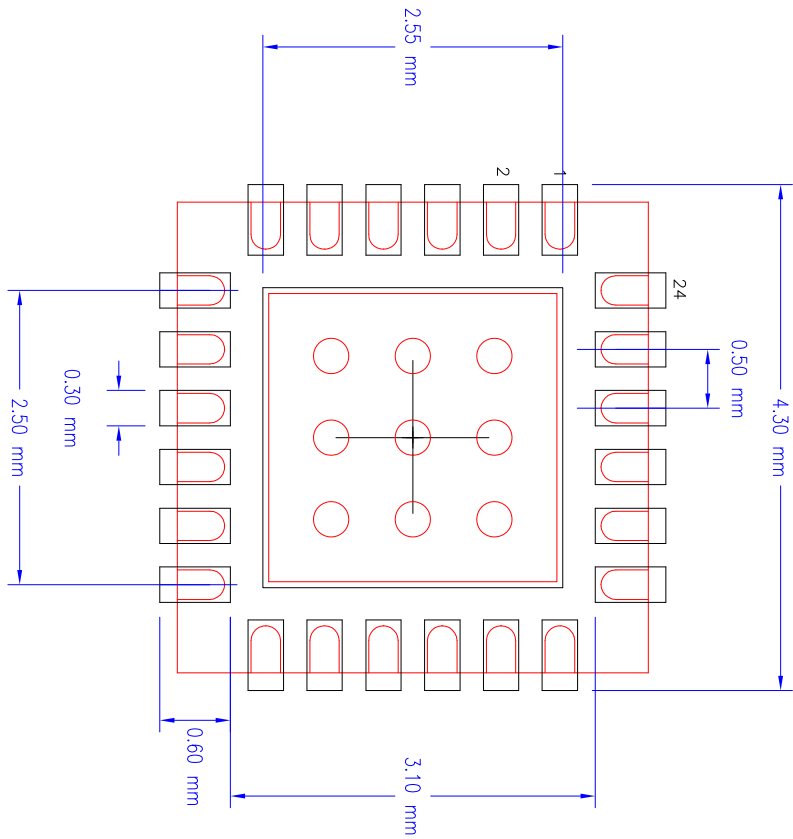
Package Outline and Dimensions (NLG24), cont.

NLG24 RECOMMENDED FOOTPRINT 2.45 mm SQ EPAD

REVISIONS			
REV	DESCRIPTION	DATE	APPROVED
00	INITIAL RELEASE	11/19/10	JG
01	ADD LAND PATTERN	11/19/10	JG

TOLERANCES UNLESS SPECIFIED		6024 Silver Creek Valley Road San Jose, CA 95138 PHONE: (408) 284-8200 FAX: (408) 284-8591
PRECISION	ANGULAR	
XXXX	Z	
XXXX	XXXX	
APPROVALS	DATE	TITLE
DRAWN <i>gk</i>	11/19/10	NL/NLG24 PACKAGE OUTLINE
CHECKED		4.0 x 4.0 mm BODY 0.5 mm PITCH VQFPN
SIZE	DRAWING No.	REV
C	PSC-4192	01
DO NOT SCALE DRAWING		SHEET 2 OF 2

Ordering Information

Part / Order Number	Shipping Packaging	Package	Temperature
9DBV0241AKLF	Tubes	24-pin VFQFPN	0 to +70° C
9DBV0241AKLFT	Tape and Reel	24-pin VFQFPN	0 to +70° C
9DBV0241AKILF	Tubes	24-pin VFQFPN	-40 to +85° C
9DBV0241AKILFT	Tape and Reel	24-pin VFQFPN	-40 to +85° C

"LF" suffix to the part number are the Pb-Free configuration and are RoHS compliant.

"A" is the device revision designator (will not correlate with the datasheet revision).

Revision History

Rev.	Initiator	Issue Date	Description	Page #
A	RDW	8/13/2012	<ol style="list-style-type: none"> Updated electrical characteristics tables. Move to final. 	5-8
B	RDW	9/6/2014	<ol style="list-style-type: none"> Changed VIH min. from 0.65*VDD to 0.75*VDD Changed VIL max. from 0.35*VDD to 0.25*VDD Added missing mid-level input voltage spec (VIM) of 0.4*VDD to 0.6*VDD. Changed Shipping Packaging from "Trays" to Tubes". Reformatted to new template 	Various
C	RDW	8/10/2015	<ol style="list-style-type: none"> Updated front page text for family consistency Updated block diagram for family consistency Updated pin configuration to indicate that paddle is ground Added epad as pin 25 to pin descriptions Replaced "Driving LVDS" with "Alternate Terminations", adding reference to AN-891. Updated "Clock Input Parameters Table" correcting inconsistency with PCIe SIG specifications. Widened allowable input frequency at each PLL mode frequency. Updated phase jitter parameters with 12k-20M additive phase jitter and added additive phase jitter graph. Updated NLG24 package drawing with actual package info instead of generic drawing. 	1,2,4,5,6,7,8, 14
D	RDW	9/11/2015	<ol style="list-style-type: none"> Corrected block diagram from clock generator to ZDB buffer 	1
E	RDW	11/4/2015	<ol style="list-style-type: none"> Minor typographical corrections throughout the data sheet Updated test load diagram to generic diagram. Length of test load listed outside the drawing. Minor updates to electrical tables for formatting. Removed Schmitt trigger info and output high/low voltage specifications for single-ended outputs, since this part does not have any. "Low-Power HCSL Outputs" table: corrected inversion of slew rate setting with specifications. Changed reference from 2 V/ns and 3 V/ns to slow setting and fast setting. Also change references in SMBus Bytes[3:2] "Low-Power HCSL Outputs" table: Removed Vswing parameter since this is an input parameter and is covered in "Clock Input Parameters" Table. Reduced current consumption limits. Minor updates to other electrical tables. 	Various, 4-8,11
F	RDW	4/22/2016	<ol style="list-style-type: none"> Updated max frequency of 100MHz PLL mode to 140MHz Updated max frequency of 125MHz PLL mode to 175MHz Updated max frequency of 50MHz PLL mode to 65MHz 	6



Corporate Headquarters
6024 Silver Creek Valley Road
San Jose, CA 95138 USA

Sales
1-800-345-7015 or 408-284-8200
Fax: 408-284-2775
www.idt.com/go/sales

Tech Support
www.idt.com/go/support

DISCLAIMER Integrated Device Technology, Inc. (IDT) and its subsidiaries reserve the right to modify the products and/or specifications described herein at any time and at IDT's sole discretion. All information in this document, including descriptions of product features and performance, is subject to change without notice. Performance specifications and the operating parameters of the described products are determined in the independent state and are not guaranteed to perform the same way when installed in customer products. The information contained herein is provided without representation or warranty of any kind, whether express or implied, including, but not limited to, the suitability of IDT's products for any particular purpose, an implied warranty of merchantability, or non-infringement of the intellectual property rights of others. This document is presented only as a guide and does not convey any license under intellectual property rights of IDT or any third parties.

IDT's products are not intended for use in applications involving extreme environmental conditions or in life support systems or similar devices where the failure or malfunction of an IDT product can be reasonably expected to significantly affect the health or safety of users. Anyone using an IDT product in such a manner does so at their own risk, absent an express, written agreement by IDT.

Integrated Device Technology, IDT and the IDT logo are registered trademarks of IDT. Product specification subject to change without notice. Other trademarks and service marks used herein, including protected names, logos and designs, are the property of IDT or their respective third party owners.

Copyright ©2016 Integrated Device Technology, Inc.. All rights reserved.

Компания «Океан Электроники» предлагает заключение долгосрочных отношений при поставках импортных электронных компонентов на взаимовыгодных условиях!

Наши преимущества:

- Поставка оригинальных импортных электронных компонентов напрямую с производств Америки, Европы и Азии, а так же с крупнейших складов мира;
- Широкая линейка поставок активных и пассивных импортных электронных компонентов (более 30 млн. наименований);
- Поставка сложных, дефицитных, либо снятых с производства позиций;
- Оперативные сроки поставки под заказ (от 5 рабочих дней);
- Экспресс доставка в любую точку России;
- Помощь Конструкторского Отдела и консультации квалифицированных инженеров;
- Техническая поддержка проекта, помощь в подборе аналогов, поставка прототипов;
- Поставка электронных компонентов под контролем ВП;
- Система менеджмента качества сертифицирована по Международному стандарту ISO 9001;
- При необходимости вся продукция военного и аэрокосмического назначения проходит испытания и сертификацию в лаборатории (по согласованию с заказчиком);
- Поставка специализированных компонентов военного и аэрокосмического уровня качества (Xilinx, Altera, Analog Devices, Intersil, Interpoint, Microsemi, Actel, Aeroflex, Peregrine, VPT, Syfer, Eurofarad, Texas Instruments, MS Kennedy, Miteq, Cobham, E2V, MA-COM, Hittite, Mini-Circuits, General Dynamics и др.);

Компания «Океан Электроники» является официальным дистрибьютором и эксклюзивным представителем в России одного из крупнейших производителей разъемов военного и аэрокосмического назначения «JONHON», а так же официальным дистрибьютором и эксклюзивным представителем в России производителя высокотехнологичных и надежных решений для передачи СВЧ сигналов «FORSTAR».



JONHON

«JONHON» (основан в 1970 г.)

Разъемы специального, военного и аэрокосмического назначения:

(Применяются в военной, авиационной, аэрокосмической, морской, железнодорожной, горно- и нефтедобывающей отраслях промышленности)

«FORSTAR» (основан в 1998 г.)

ВЧ соединители, коаксиальные кабели,
кабельные сборки и микроволновые компоненты:

(Применяются в телекоммуникациях гражданского и специального назначения, в средствах связи, РЛС, а так же военной, авиационной и аэрокосмической отраслях промышленности).



Телефон: 8 (812) 309-75-97 (многоканальный)

Факс: 8 (812) 320-03-32

Электронная почта: ocean@oceanchips.ru

Web: <http://oceanchips.ru/>

Адрес: 198099, г. Санкт-Петербург, ул. Калинина, д. 2, корп. 4, лит. А