

LT3964
36V Synchronous Dual LED
Driver with I²C

DESCRIPTION

The DC2424A is a 36V synchronous dual LED driver with I²C featuring the LT[®]3964. It drives two separate LEDs (or channels of LEDs) at 1A when V_{IN} is between 5V and 36V. DC2424A runs at 2MHz switching frequency. Its two channels can drive separate LED strings which can have different currents, voltages, or dimming ratios. It can be controlled with I²C communications or it can be run in non-I²C mode with proper ADDR pin settings. It is protected against both open and short LED conditions and reports the faults. In I²C mode, faults can be enabled or disabled. Up to 9 different DC2424As can be placed on the same I²C bus with unique addresses. A graphical user interface (GUI) is available through QuikEval™ when connected to a DC2026C Linduino® One demo circuit.

The LT3964 has an input voltage range from 4V to 36V. It has two independent 1.6A, 40V bucks with internal, synchronous 40V switches for high efficiency and small size. It has adjustable switching frequency between 200kHz and 2MHz. It can be synchronized to an external source or programmed with a clock output (CLKOUT) from the serial interface. The PWMTG high side PWM MOSFET drivers assist with short-circuit protection and versatility. Although the demo circuit is optimized for just one LED per channel, it can be altered to be buck regulators with as high as 33V of LEDs if V_{IN} is high enough and circuit components are changed appropriately.

In non-I²C mode, each channel can separately be PWM- and analog-dimmed by placing a PWM signal or CTRL voltage on the provided turrets. In I²C mode, each channel can be dimmed to up to 8192:1 and analog dimmed to a high ratio using serial communications.

Small ceramic input and output capacitors are used to save space and cost. The open LED overvoltage protection uses the IC's constant voltage regulation loop to regulate the output to approximately 4.2V if the LED string is opened. There is a protection diode from each LED+ to GND to prevent negative ringing during a short-circuit condition.

Undervoltage lockout can be adjusted on the circuit with a few simple resistor choices. The output voltage (overvoltage protection) can be adjusted by changing the feedback resistors for higher string voltages. Other components may need to be changed to accommodate higher voltages also.

The LT3964 data sheet gives a complete description of the device, operation and applications information. The data sheet must be read in conjunction with this demo manual for DC2424A. The LT3964EUHE is assembled in a 36-lead plastic 5mm × 6mm QFN package with a thermally enhanced ground pad. Proper board layout is essential for maximum thermal performance. See the data sheet Layout Considerations section.

Design files for this circuit board are available at
<http://www.linear.com/demo/DC2424A>

LT, LT, LTC, LTM, Linear Technology, the Linear logo and Linduino are registered trademarks and QuikEval is a trademark of Analog Devices, Inc. All other trademarks are the property of their respective owners.

DEMO MANUAL

DC2424A

PERFORMANCE SUMMARY Specifications are at $T_A = 25^\circ\text{C}$

PARAMETER	CONDITION	MIN	TYP	MAX
Input Voltage PV_{IN} Range	Operating	5V		36V
Switching Frequency	$R8 = 27.4k$		2.0MHz	
I_{LED1}, I_{LED2}	$R12 = R16 = 0.1\Omega$		1.0A	
Open LED Voltage V_{OUT} (V COUT)	$R10 = R14 = 1M$ $R11 = R15 = 383k$		4.2V	
Efficiency (100% PWM DC)	12.0V PV_{IN} , 2MHz, $I_{LED1} = I_{LED2} = 1.0A$, 1 LED		81%	
V_{LED} Range	$R10 = R14 = 1M$ $R11 = R15 = 383k$	2.5V		3.6V
I ² C PWM Dimming Frequency	$R8 = 27.4k$		244Hz	
PV_{IN} Undervoltage Lockout (Falling)	$R1 = 332k$ $R2 = 102k$		5.0V	
PV_{IN} Turn-On Voltage (Rising)	$R1 = 332k$ $R2 = 102k$		6.0V	

QUICK START PROCEDURE

How to Operate in Non-I²C Mode

The DC2424A is easy to set up to evaluate the performance of the LT3964 in non-I²C mode. Follow the procedure below:

1. With power off, connect a single LED between LED1+ and LED1– terminals and the same for LED2+ and LED2–. Connect the EN/UVLO terminal to GND to keep the circuit shut down. With power off, connect the input power supply to the V_{IN} and GND terminals. Make sure that the input voltage will not exceed 36V.
2. For non-I²C mode operation, set both JP1 and JP2 (ADDR1 and ADDR2) to 0. The 00 address pins setting is for non-I²C mode, but all other settings are for I²C serial communications mode.
3. Turn the input power supply on and make sure the voltage is between 8V and 36V to start operation.
4. Release the EN/UVLO-to-GND connection.
5. Observe the LED string running at the programmed LED current.
6. To change the brightness with analog dimming in non-I²C mode, simply attach a voltage source the CTRL1 and/or CTRL2 terminals and set the voltage between 0V and 1.5V. See data sheet for details.

7. To change brightness with external PWM dimming in non-I²C mode, simply attach a rectangular waveform with varying duty cycle to the PWM1 and/or PWM2 terminals.

How to Operate with Graphical User Interface (GUI) – I²C Serial Communications Mode

1. With power off, connect a single LED between LED1+ and LED1– terminals and the same for LED2+ and LED2–. Connect the EN/UVLO terminal to GND to keep the circuit shut down. With power off, connect the input power supply to the V_{IN} and GND terminals. Make sure that the input voltage will not exceed 36V.
2. For I²C serial communications operation, set JP1 (ADDR1) to 0 and JP2 (ADDR2) to 1. The 01 address setting works seamlessly with the DC2424A GUI in QuikEval. In general, serial communications can be used with the LT3964 as long as ADDR1 and ADDR2 settings are anything other than 00. There are three states to each ADDR pin, 0, 1, or float. There are 9 unique I²C address settings.
3. Connect a ribbon cable between the J1 serial communications connection and a Linduino One (DC2026C) demo circuit.
4. Connect a USB cable between a PC and the DC2026C.
5. Turn on 12V power to the PV_{IN} and GND pins of the DC2424A.

QUICK START PROCEDURE

- Launch QuikEval (find installation instructions on the www.linear.com website) and the LT3964 DC2424A GUI launches.
- Use the DC2424A GUI in QuikEval to test the performance of the LT3964 demo circuit.

NOTE: A DC2424A LT3964 GUI user guide is posted on the landing page for the LT3964 and DC2424A. It contains the GUI pages, commands, and other details. Please contact Linear support for help with the GUI and User Guide.

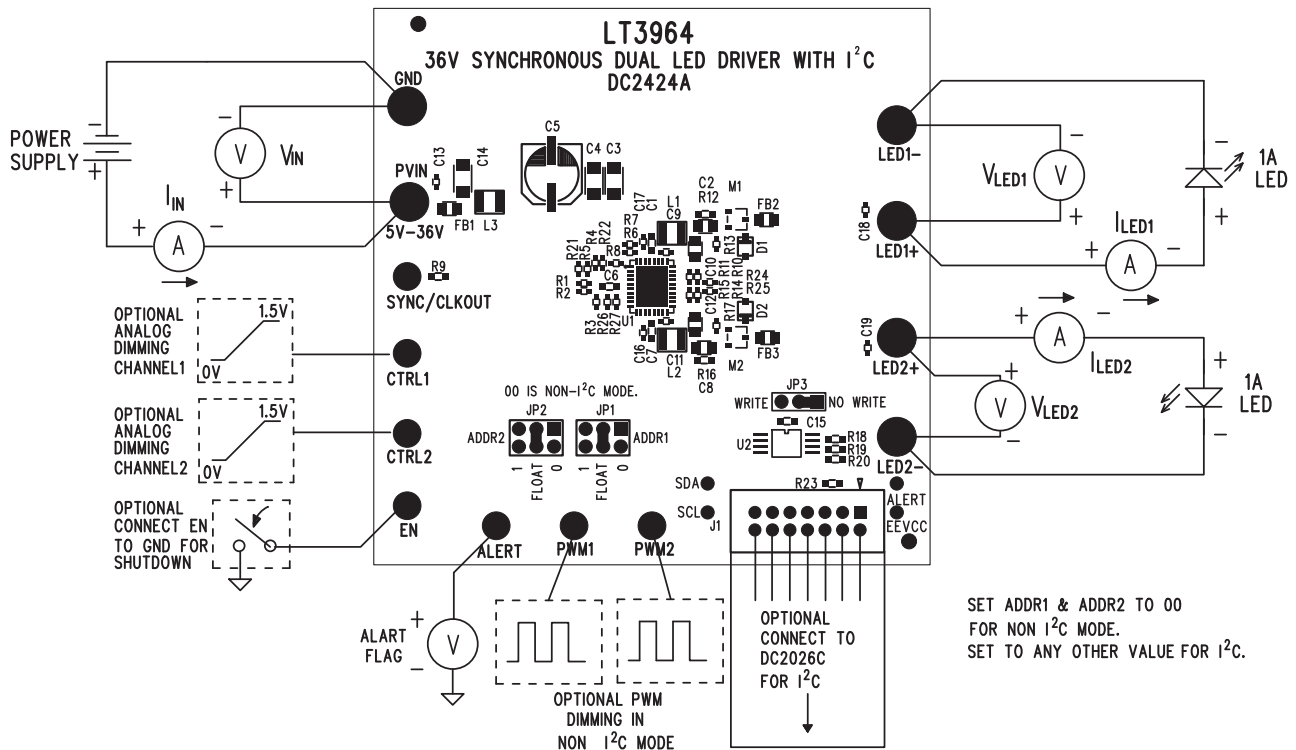

Figure 1. Test Procedure Setup Drawing for DC2424A

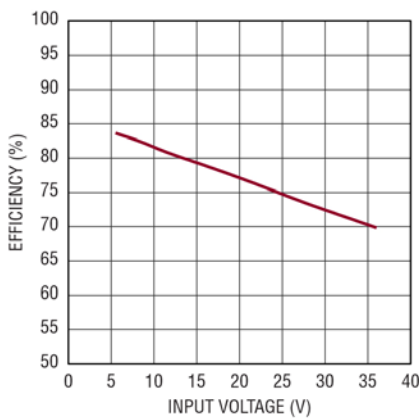

Figure 2. DC2424A Efficiency vs Input Voltage with 2MHz and Single 1A LED on Each Channel

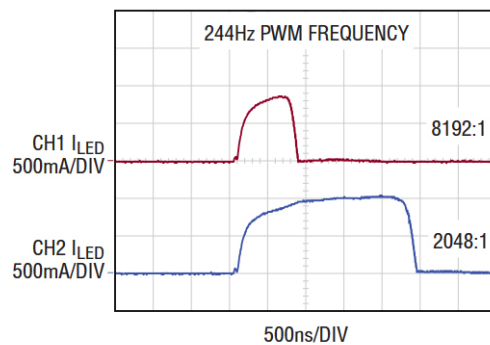

Figure 3. DC2424A PWM Dimming Using I²C Settings for 8192:1 and 2048:1 Dimming Ratios

DEMO MANUAL

DC2424A

PARTS LIST

ITEM	QTY	REFERENCE	PART DESCRIPTION	MANUFACTURER/PART NUMBER
Required Circuit Components				
1	2	C1, C7	CAP., 1 μ F, X5R, 50V, 10%, 0603	MURATA, GRM188R61H105KAALD
2	2	C10, C12	CAP., 4.7 μ F, X7R, 10V, 10%, 0805	MURATA, GRM21BR71A475KA73L
4	2	C3, C4	CAP., 10 μ F, X5R, 50V, 10%, 1206	MURATA, GRM31CR61H106KA12L
6	1	C6	CAP., 2.2 μ F, X5R, 25V, 10%, 0603	MURATA, GRM188R61E225ME84D
7	2	C9, C11	CAP., 0.22 μ F, X5R, 25V, 10%, 0402	MURATA, GRM155R61E224KE01D
19	2	L1, L2	INDUCTOR, 2.2 μ H	WURTH ELEKTRONIK, 74438323022
21	2	M1, M2	MOSFET P-CH, 20V, 5.9A, SOT-23	VISHAY, Si2365EDS-T1-GE3
22	1	R1	RES., 332k, 1/16W, 1%, 0402	VISHAY, CRCW0402332KFKED
24	1	R2	RES., 102k, 1/16W, 1%, 0402	VISHAY, CRCW0402102KFKED
25	1	R3	RES., 100k, 1/16W, 1%, 0402	VISHAY, CRCW0402100KFKED
23	1	R6	RES., 499k, 1/16W, 1%, 0402	VISHAY, CRCW0402499KFKED
26	1	R7	RES., 165K, 1/16W, 1%, 0402	VISHAY, CRCW0402165KFKED
27	1	R8	RES., 27.4k, 1/16W, 1%, 0402	VISHAY, CRCW040227K4FKED
28	2	R11, R15	RES., 383k, 1/16W, 1%, 0402	VISHAY, CRCW0402383KFKED
30	2	R10, R14	RES., 1M, 1/16W, 1%, 0402	VISHAY, CRCW04021M00FKED
31	2	R12, R16	RES., 0.1 Ω , 1/2W, 1%, 0805	SUSUMU, KRL1220E-M-R100-F-T5
34	1	U1	I.C. LED DRIVER QFN-5 \times 6	LINEAR, LT3964EUHE#PBF
Optional Electrical Components				
3	0	C2, C8 (OPT)	CAP., 0603	OPTION
5	1	C5	CAP., ALUM., 33 μ F, 50V, 6.3 \times 7.7	SUNCON, 50CE33FS
8	0	C13, C16, C18, C19 (OPT)	CAP., 0402	OPTION
9	0	C14 (OPT)	CAP., 1206	OPTION
10	1	C15	CAP., 0.1 μ F, X7R, 16V, 10%, 0603	MURATA, GRM188R71C104KA01D
11	2	D1, D2	DIODE SCHOTTKY, 20V, 1A, SOD323F	NXP, PMEG2010EJ, 115
14	0	FB1, FB2, FB3 (OPT)	FERRITE BEAD, CHIP, 0805	
20	0	L3 (OPT)	INDUCTOR, 2.2 μ H	WURTH ELEKTRONIK, 74438323022
25	4	R4, R5, R26, R27	RES., 100k, 1/16W, 1%, 0402	VISHAY, CRCW0402100KFKED
29	0	R9, R23 (OPT)	RES, OPT, 0603	
32	0	R13, R17, R21, R22, R24, R25	RES, 0402	OPTION
33	3	R18, R19, R20	RES., 4.99k, 1/10W, 1%, 0603	VISHAY, CRCW06034K99FKEA
35	1	U2	I.C., EEPROM 2-KBIT 400kHz 8-TSSOP	MICROCHIP, 24LC025-I/ST
Hardware				
1	6	E1-E6	TESTPOINT, TURRET, 0.094" PBF	MILL-MAX, 2501-2-00-80-00-00-07-0
2	7	E7-E13	TESTPOINT, TURRET, 0.061" PBF	MILL-MAX, 2308-2-00-80-00-00-07-0
3	2	JP1, JP2	HEADER, 2 \times 3 PIN, 0.079 DOUBLE ROW	WURTH ELEKTRONIK, 62000621121
4	1	JP3	HEADOR, 3 \times 1 PIN, 0.079", SINGLE ROW	WURTH ELEKTRONIK, 62000311121
5	3	XJP1, XJP2, XJP3	SHUNT, 0.079" CENTER	WURTH ELEKTRONIK, 60800213421
6	1	J1	HEADER, 2 \times 7 DUAL ROW	MOLEX, 87831-1420

SCHEMATIC DIAGRAM

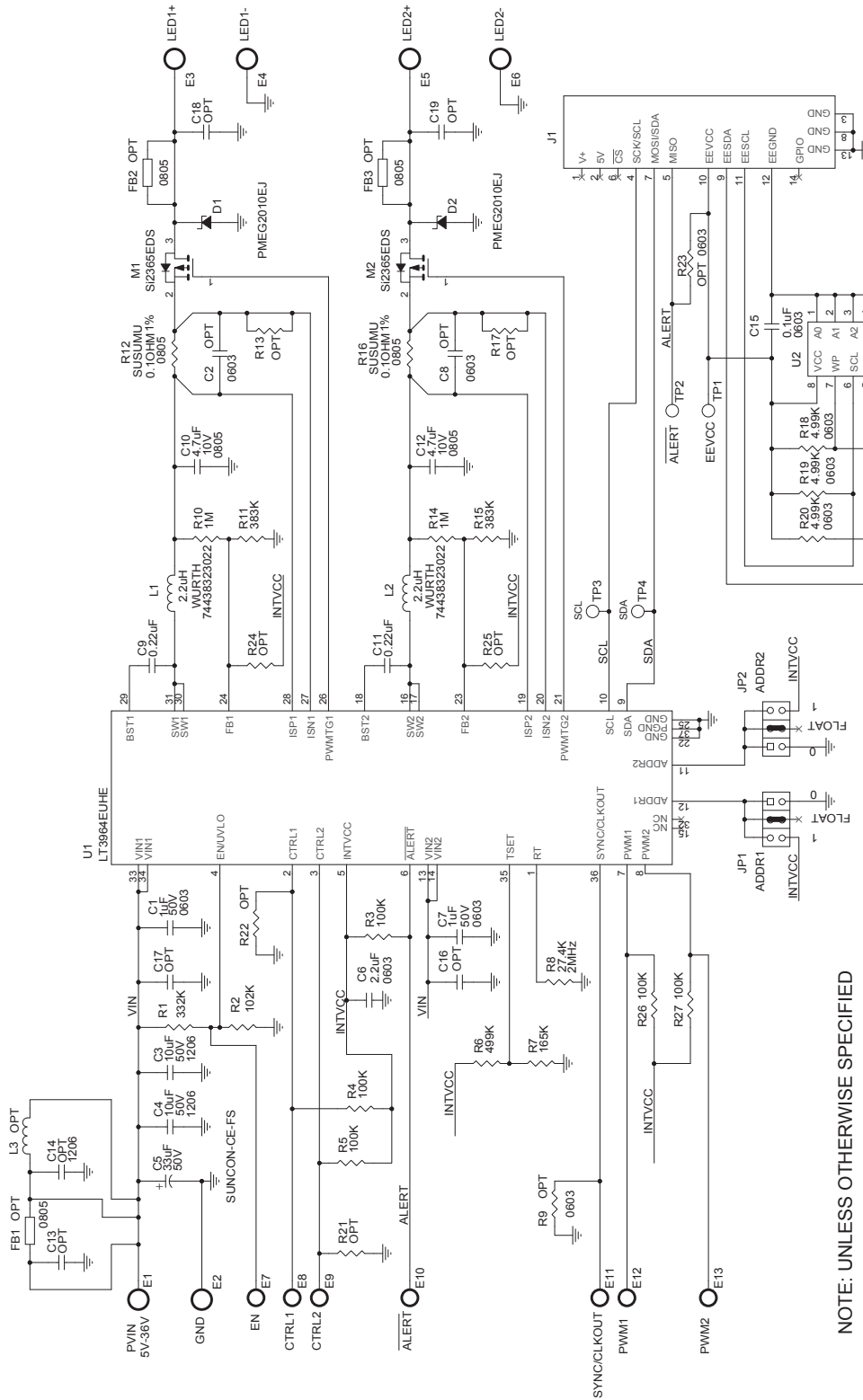

NOTE: UNLESS OTHERWISE SPECIFIED

1. ALL RESISTORS ARE 0402.
- ALL CAPACITORS ARE 0402.

00 IS NON-I²C MODE.

LINEAR TECHNOLOGY

1630 McCarty Blvd.
Milpitas, CA 95035
Tel: 408.253.1800 Fax: 408.253.1807
www.linear.com
LTC Confidential-For Customer Use Only

CUSTOMER NOTICE
LINEAR TECHNOLOGY ASSUMES NO RESPONSIBILITY FOR THE DESIGN OR OPERATION OF ANY CIRCUIT THAT MEETS CUSTOMER-SUPPLIED SPECIFICATIONS. HOWEVER, IT REMAINS THE CUSTOMER'S RESPONSIBILITY TO DESIGN AND TEST ANY CIRCUIT TO MEET ALL APPLICATION, COMPONENT SUBSTITUTION AND PRINTED CIRCUIT BOARD MANUFACTURING REQUIREMENTS. CUSTOMER PERFORMANCE AND RELIABILITY CONTACT LINEAR TECHNOLOGY APPLICATIONS ENGINEERING FOR ASSISTANCE.

THIS CIRCUIT IS PROPRIETARY TO LINEAR TECHNOLOGY AND SUPPLIED FOR USE WITH LINEAR TECHNOLOGY PARTS.

TITLE: SCHEMATIC	SIZE: IC NO.	REV: 3
36V SYNCHRONOUS DUAL LED DRIVER WITH I ² C	LT3964EUHE	
DATE: Thursday, July 13, 2017	DC2424A	SHEET 1 OF 1

DEMO MANUAL

DC2424A

DEMONSTRATION BOARD IMPORTANT NOTICE

Linear Technology Corporation (LTC) provides the enclosed product(s) under the following **AS IS** conditions:

This demonstration board (DEMO BOARD) kit being sold or provided by Linear Technology is intended for use for **ENGINEERING DEVELOPMENT OR EVALUATION PURPOSES ONLY** and is not provided by LTC for commercial use. As such, the DEMO BOARD herein may not be complete in terms of required design-, marketing-, and/or manufacturing-related protective considerations, including but not limited to product safety measures typically found in finished commercial goods. As a prototype, this product does not fall within the scope of the European Union directive on electromagnetic compatibility and therefore may or may not meet the technical requirements of the directive, or other regulations.

If this evaluation kit does not meet the specifications recited in the DEMO BOARD manual the kit may be returned within 30 days from the date of delivery for a full refund. **THE FOREGOING WARRANTY IS THE EXCLUSIVE WARRANTY MADE BY THE SELLER TO BUYER AND IS IN LIEU OF ALL OTHER WARRANTIES, EXPRESSED, IMPLIED, OR STATUTORY, INCLUDING ANY WARRANTY OF MERCHANTABILITY OR FITNESS FOR ANY PARTICULAR PURPOSE. EXCEPT TO THE EXTENT OF THIS INDEMNITY, NEITHER PARTY SHALL BE LIABLE TO THE OTHER FOR ANY INDIRECT, SPECIAL, INCIDENTAL, OR CONSEQUENTIAL DAMAGES.**

The user assumes all responsibility and liability for proper and safe handling of the goods. Further, the user releases LTC from all claims arising from the handling or use of the goods. Due to the open construction of the product, it is the user's responsibility to take any and all appropriate precautions with regard to electrostatic discharge. Also be aware that the products herein may not be regulatory compliant or agency certified (FCC, UL, CE, etc.).

No License is granted under any patent right or other intellectual property whatsoever. **LTC assumes no liability for applications assistance, customer product design, software performance, or infringement of patents or any other intellectual property rights of any kind.**

LTC currently services a variety of customers for products around the world, and therefore this transaction **is not exclusive**.

Please read the DEMO BOARD manual prior to handling the product. Persons handling this product must have electronics training and observe good laboratory practice standards. **Common sense is encouraged.**

This notice contains important safety information about temperatures and voltages. For further safety concerns, please contact a LTC application engineer.

Mailing Address:

Linear Technology
1630 McCarthy Blvd.
Milpitas, CA 95035

Copyright © 2004, Linear Technology Corporation

Компания «Океан Электроники» предлагает заключение долгосрочных отношений при поставках импортных электронных компонентов на взаимовыгодных условиях!

Наши преимущества:

- Поставка оригинальных импортных электронных компонентов напрямую с производств Америки, Европы и Азии, а так же с крупнейших складов мира;
- Широкая линейка поставок активных и пассивных импортных электронных компонентов (более 30 млн. наименований);
- Поставка сложных, дефицитных, либо снятых с производства позиций;
- Оперативные сроки поставки под заказ (от 5 рабочих дней);
- Экспресс доставка в любую точку России;
- Помощь Конструкторского Отдела и консультации квалифицированных инженеров;
- Техническая поддержка проекта, помощь в подборе аналогов, поставка прототипов;
- Поставка электронных компонентов под контролем ВП;
- Система менеджмента качества сертифицирована по Международному стандарту ISO 9001;
- При необходимости вся продукция военного и аэрокосмического назначения проходит испытания и сертификацию в лаборатории (по согласованию с заказчиком);
- Поставка специализированных компонентов военного и аэрокосмического уровня качества (Xilinx, Altera, Analog Devices, Intersil, Interpoint, Microsemi, Actel, Aeroflex, Peregrine, VPT, Syfer, Eurofarad, Texas Instruments, MS Kennedy, Miteq, Cobham, E2V, MA-COM, Hittite, Mini-Circuits, General Dynamics и др.);

Компания «Океан Электроники» является официальным дистрибьютором и эксклюзивным представителем в России одного из крупнейших производителей разъемов военного и аэрокосмического назначения «JONHON», а так же официальным дистрибьютором и эксклюзивным представителем в России производителя высокотехнологичных и надежных решений для передачи СВЧ сигналов «FORSTAR».



JONHON

«JONHON» (основан в 1970 г.)

Разъемы специального, военного и аэрокосмического назначения:

(Применяются в военной, авиационной, аэрокосмической, морской, железнодорожной, горно- и нефтедобывающей отраслях промышленности)

«FORSTAR» (основан в 1998 г.)

ВЧ соединители, коаксиальные кабели, кабельные сборки и микроволновые компоненты:

(Применяются в телекоммуникациях гражданского и специального назначения, в средствах связи, РЛС, а так же военной, авиационной и аэрокосмической отраслях промышленности).



Телефон: 8 (812) 309-75-97 (многоканальный)

Факс: 8 (812) 320-03-32

Электронная почта: ocean@oceanchips.ru

Web: <http://oceanchips.ru/>

Адрес: 198099, г. Санкт-Петербург, ул. Калинина, д. 2, корп. 4, лит. А