



Ultra-Small, Hex Voltage, Microprocessor Supervisor

MAX16055

General Description

The MAX16055 precision hex voltage microprocessor (μ P) supervisory circuit monitors up to six system-supply voltages and asserts a single reset when any one supply voltage drops below its preset threshold. The device significantly reduces system size and component count while improving reliability compared to multiple ICs or discrete components.

A variety of factory-trimmed threshold voltages are available to accommodate different supply voltages and tolerance with minimal external components. The MAX16055 includes internally fixed threshold options for monitoring 3.3V, 3.0V, 2.5V, 1.8V, 1.5V, 1.2V, 1.1V, 1.0V, and 0.9V supplies with -5% or -10% tolerance. The MAX16055 is also available with one to five adjustable threshold inputs to monitor voltages down to 0.5V.

A single active-low, open-drain output asserts when any monitored input falls below its associated threshold. The reset output features a weak internal pullup (typically 70 μ A) to supply input IN1. The reset output remains low for the reset timeout period (140ms, min) after all voltages rise above the selected thresholds. The reset output remains valid as long as either IN1 or IN2 input voltage is above 1V. The MAX16055 is available in a small 10-pin μ MAX[®] (3mm x 3mm) package. The MAX16055 operates over the -40°C to +125°C automotive temperature range.

Applications

Telecommunications	Networking Equipment
High-End Printers	Industrial Equipment
Desktop and Notebook Computers	Set-Top Boxes
	Servers/Workstations
Data Storage Equipment	

μ MAX is a registered trademark of Maxim Integrated Products, Inc.

Pin Configuration

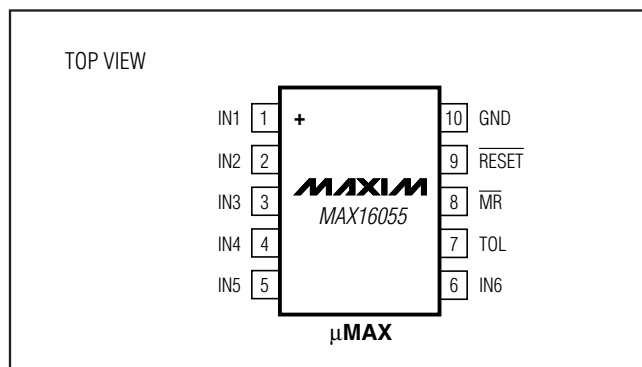

Features

- ◆ Precision Factory-Set Reset Threshold Options 3.3V, 3.0V, 2.5V, 1.8V, 1.5V, 1.2V, 1.1V, 1.0V, and 0.9V
- ◆ Adjustable Voltage Threshold Monitors Down to 0.5V with 1.5% Accuracy
- ◆ Open-Drain $\overline{\text{RESET}}$ Output with 70 μ A Internal Pullup
- ◆ Fixed 140ms (min) Reset Timeout Period
- ◆ Manual Reset Input
- ◆ Reset Valid for IN1 \geq 1V or IN2 \geq 1V
- ◆ Tolerance Select (5%/10%) Input
- ◆ Immune to Short Supply Transients

Ordering Information

PART	TEMP RANGE	PIN-PACKAGE
MAX16055_AUB+*	-40°C to +125°C	10 μ MAX

+ Denotes a lead(Pb)-free/RoHS-compliant package.

* Insert the desired threshold option letter from the Selector Guide into the blank to complete the part number. Contact factory for availability.

Typical Operating Circuit

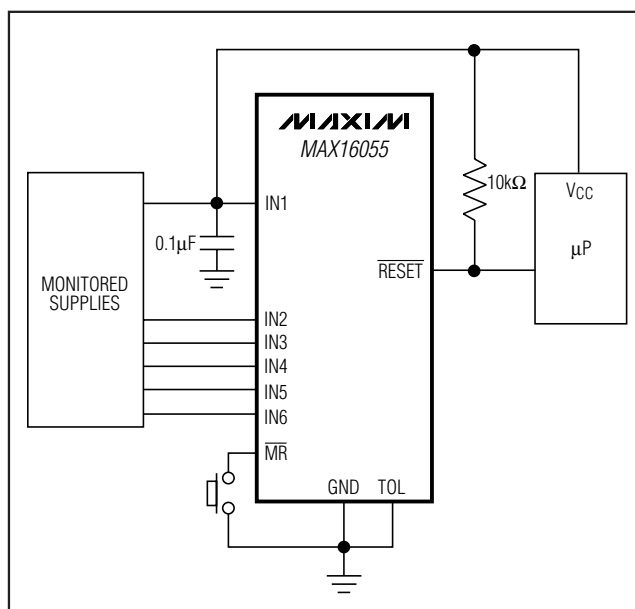

Ultra-Small, Hex Voltage, Microprocessor Supervisor

ABSOLUTE MAXIMUM RATINGS

RESET, TOL, MR, IN ₋ to GND	-0.3V to +6V	Operating Temperature Range	-40°C to +125°C
Input/Output Current (all pins)	20mA	Storage Temperature Range	-65°C to +150°C
Continuous Power Dissipation (T _A = +70°C)		Junction Temperature	+150°C
10-Pin μMAX (derate 5.6mW/°C above +70°C)	444mW	Lead Temperature (soldering, 10s)	+300°C

Stresses beyond those listed under "Absolute Maximum Ratings" may cause permanent damage to the device. These are stress ratings only, and functional operation of the device at these or any other conditions beyond those indicated in the operational sections of the specifications is not implied. Exposure to absolute maximum rating conditions for extended periods may affect device reliability.

ELECTRICAL CHARACTERISTICS

(V_{IN1} = 1V to 5.5V, T_A = -40°C to +125°C, unless otherwise noted. Typical values are at V_{IN1} = 3.3V, T_A = +25°C.) (Note 1)

PARAMETER	SYMBOL	CONDITIONS	MIN	TYP	MAX	UNIT	
Operating Voltage Range	V _{IN1}	(Note 2)	1.0		5.5	V	
Input Current (Note 3)	I _{IN-}	V _{IN-} = nominal input voltage (for IN2–IN6; 3.3V, 3.0V, 2.5V, 1.8V, 1.5V, 1.2V, 1.1V, 1.0V, 0.9V supplies)		25	40	μA	
		V _{IN1} = nominal input voltage (for +3.3V IN1 supply)		55	115		
		V _{IN-} = 0 to 0.5V or V _{ADJ} (for adjustable thresholds)	-0.1		+0.1		
Threshold Voltage	V _{TH}	V _{IN-} decreasing	3.3V, TOL = GND	3.00	3.08	3.15	V
			3.3V, TOL = V _{IN1}	2.85	2.93	3.00	
			3.0V, TOL = GND	2.70	2.78	2.85	
			3.0V, TOL = V _{IN1}	2.55	2.63	2.70	
			2.5V, TOL = GND	2.25	2.32	2.38	
			2.5V, TOL = V _{IN1}	2.13	2.19	2.25	
			1.8V, TOL = GND	1.62	1.67	1.71	
			1.8V, TOL = V _{IN1}	1.53	1.58	1.62	
			1.5V, TOL = GND	1.355	1.389	1.425	
			1.5V, TOL = V _{IN1}	1.283	1.316	1.350	
			1.2V, TOL = GND	1.084	1.112	1.140	
			1.2V, TOL = V _{IN1}	1.027	1.053	1.08	
			1.1V, TOL = GND	0.993	1.019	1.045	
			1.1V, TOL = V _{IN1}	0.941	0.965	0.99	
			1.0V, TOL = GND	0.903	0.926	0.95	
			1.0V, TOL = V _{IN1}	0.856	0.878	0.90	
0.9V, TOL = GND	0.813	0.834	0.855				
0.9V, TOL = V _{IN1}	0.770	0.790	0.810				

Ultra-Small, Hex Voltage, Microprocessor Supervisor

MAX16055

ELECTRICAL CHARACTERISTICS (continued)

($V_{IN1} = 1V$ to $5.5V$, $T_A = -40^{\circ}C$ to $+125^{\circ}C$, unless otherwise noted. Typical values are at $V_{IN1} = 3.3V$, $T_A = +25^{\circ}C$.) (Note 1)

PARAMETER	SYMBOL	CONDITIONS	MIN	TYP	MAX	UNIT	
Adjustable Threshold	V_{TH}	$V_{IN_}$ decreasing	TOL = GND	0.491	0.5	0.506	V
			TOL = V_{IN1}	0.465	0.472	0.479	
Reset Threshold Hysteresis	V_{HYST}	$V_{IN_}$ increasing relative to $V_{IN_}$ decreasing		0.3		% V_{TH}	
Reset Threshold Temperature Coefficient				60		ppm/ $^{\circ}C$	
IN_ to Reset Delay	t_{RD}	$V_{IN_}$ falling at $10mV/\mu s$ from ($V_{TH} + 50mV$) to ($V_{TH} - 50mV$)		20		μs	
Reset Timeout Period	t_{RP}		140	200	280	ms	
\overline{RESET} Output Low (Note 4)	V_{OL}	$V_{IN1} = 5V$, $I_{SINK} = 2mA$			0.3	V	
		$V_{IN1} = 2.5V$, $I_{SINK} = 1.2mA$			0.4		
		$V_{IN1} = 1.0V$, $I_{SINK} = 50\mu A$			0.3		
\overline{RESET} Output High	V_{OH}	$V_{IN1} > 2.55V$, $I_{SOURCE} = 6\mu A$ (min), \overline{RESET} not asserted	$0.8 \times V_{IN1}$			V	
\overline{RESET} Output High Source Current	I_{OH}	$V_{IN1} > 2.55V$, \overline{RESET} not asserted		70		μA	
TOL Input Current		TOL = V_{IN1}			100	nA	
\overline{MR} , TOL Input Voltage Low	V_{IL}				$0.3 \times V_{IN1}$	V	
\overline{MR} , TOL Input Voltage High	V_{IH}		$0.7 \times V_{IN1}$			V	
\overline{MR} Minimum Pulse Width			1			μs	
\overline{MR} Glitch Rejection				100		ns	
\overline{MR} -to- \overline{RESET} Delay				200		ns	
\overline{MR} Pullup Resistance			10	20	33	k Ω	

Note 1: 100% production tested at $T_A = +25^{\circ}C$. Limits over temperature guaranteed by design.

Note 2: The devices are powered from IN1.

Note 3: Monitored IN1 voltage is also the device power supply.

Note 4: RESET output is guaranteed to be in the correct state for IN1 or IN2 falling down to 1V.

Ultra-Small, Hex Voltage, Microprocessor Supervisor

Typical Operating Characteristics

($V_{IN1} = 3.3V$, $T_A = +25^\circ C$, unless otherwise noted.)

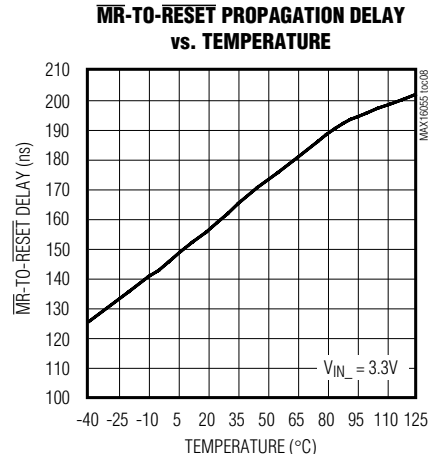
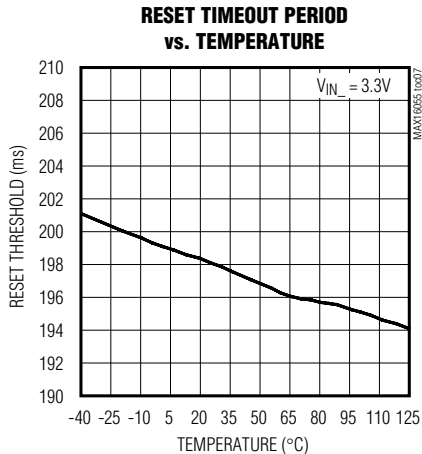
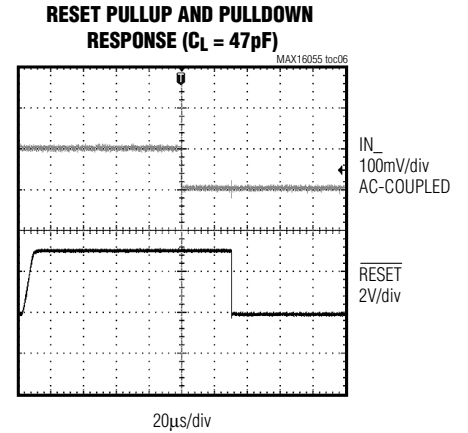
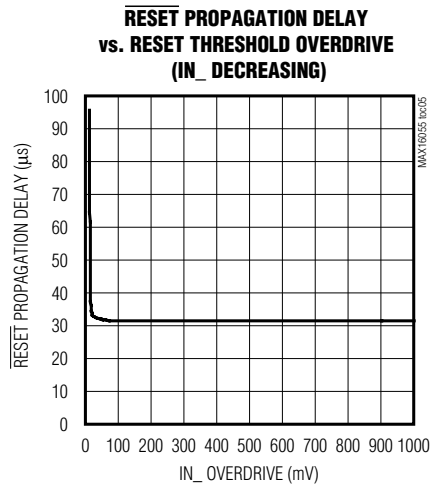
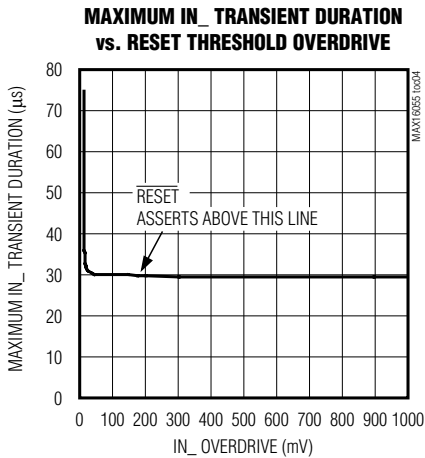
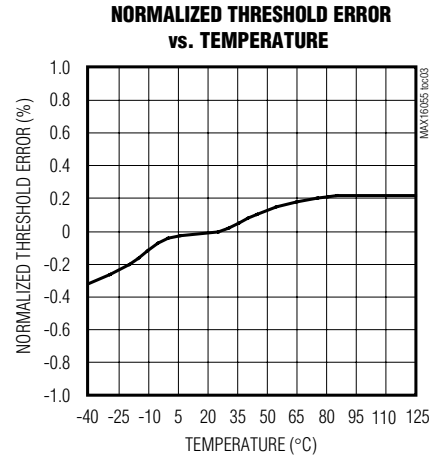
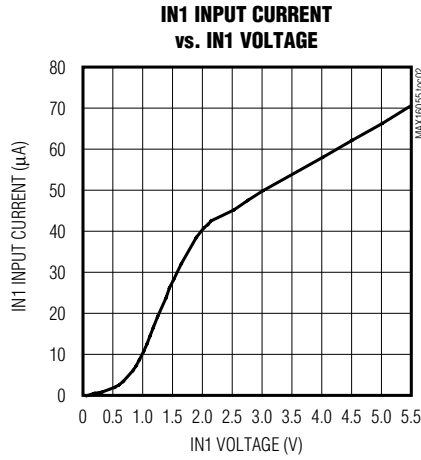
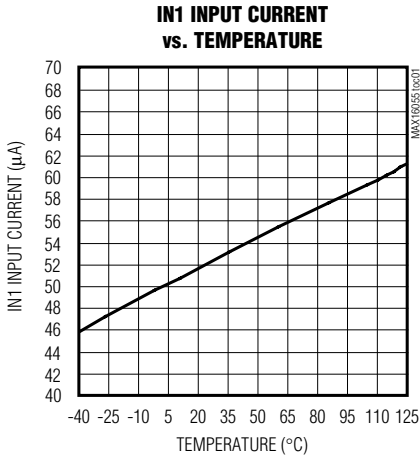

Ultra-Small, Hex Voltage, Microprocessor Supervisor

MAX16055

Typical Operating Characteristics (continued)

($V_{IN1} = 3.3V$, $T_A = +25^\circ C$, unless otherwise noted.)

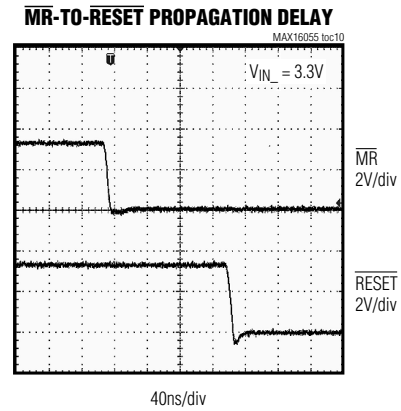
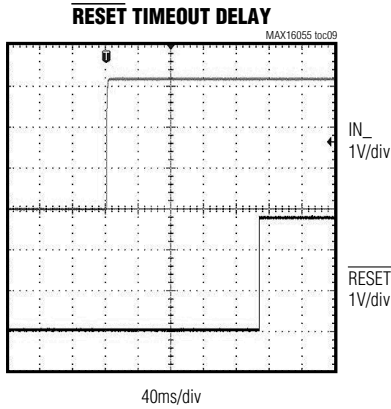

Pin Description

PIN	NAME	FUNCTION
1	IN1	Voltage Input 1. IN1 is the power-supply input and voltage monitoring input for the device. Connect a 0.1 μ F bypass capacitor from IN1 to GND. Keep IN1 or IN2 > 1V to ensure \overline{RESET} is valid.
2	IN2	Voltage Input 2. See the <i>Selector Guide</i> for voltage threshold. Keep IN1 or IN2 > 1V to ensure \overline{RESET} is valid.
3	IN3	Voltage Input 3. See the <i>Selector Guide</i> for voltage threshold.
4	IN4	Voltage Input 4. See the <i>Selector Guide</i> for voltage threshold.
5	IN5	Voltage Input 5. See the <i>Selector Guide</i> for voltage threshold.
6	IN6	Voltage Input 6. See the <i>Selector Guide</i> for voltage threshold.
7	TOL	Threshold Tolerance Input. Connect TOL to GND to select thresholds 5% below nominal. Connect TOL to IN1 to select thresholds 10% below nominal.
8	\overline{MR}	Active-Low Manual-Reset Input. When \overline{MR} is low, \overline{RESET} goes low and remains asserted for the reset timeout period after \overline{MR} is pulled high. \overline{MR} is internally pulled high by a 20k Ω pullup resistor to IN1.
9	\overline{RESET}	Active-Low Reset Output. \overline{RESET} goes low when any input (IN_) goes below the specified threshold. After all inputs rise above the specified threshold voltages, \overline{RESET} remains low for 140ms (min) before going high. The open-drain \overline{RESET} output features a weak (70 μ A) internal pullup to IN1.
10	GND	Ground

Ultra-Small, Hex Voltage, Microprocessor Supervisor

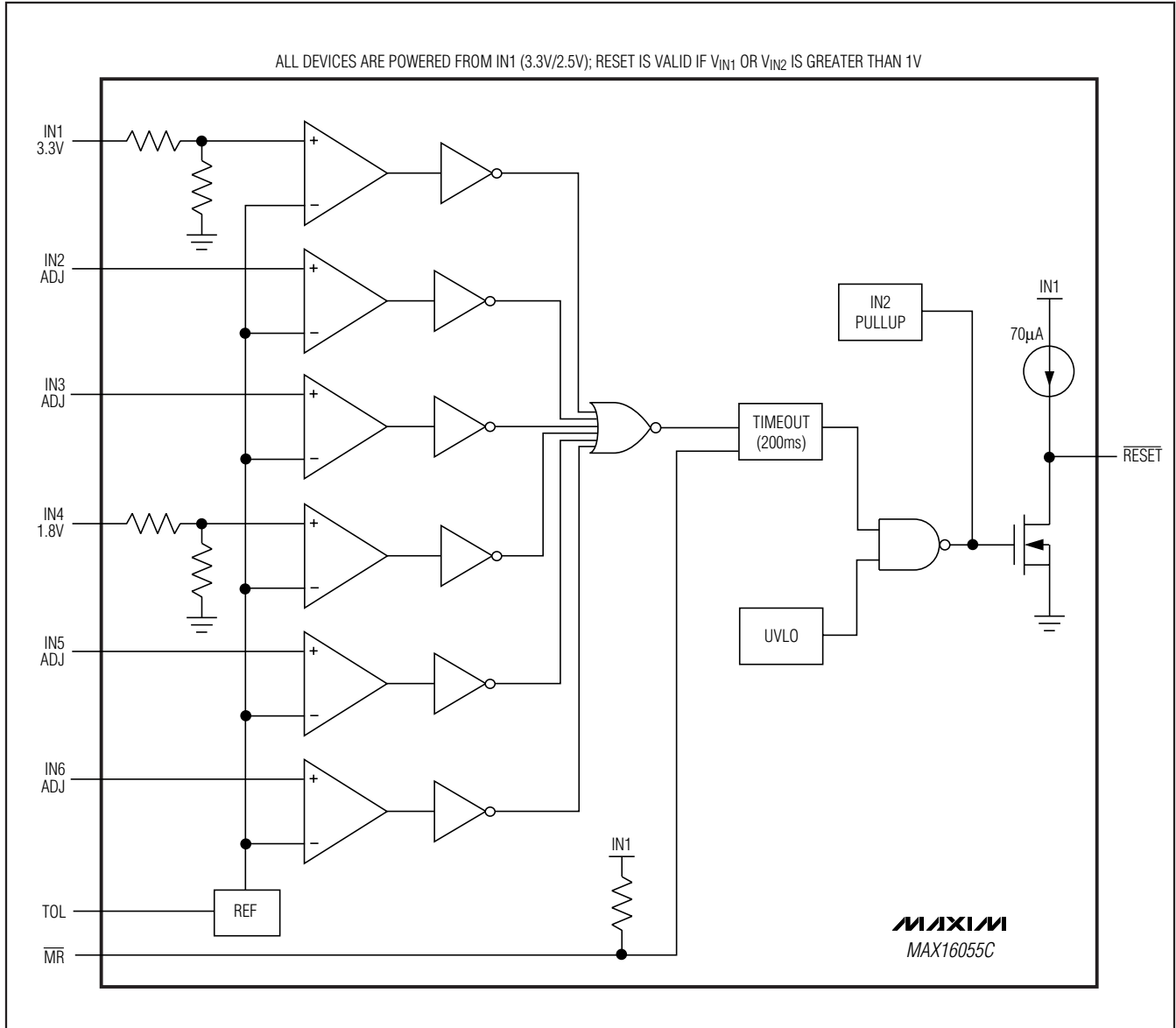

Figure 1. Functional Diagram

Detailed Description

The MAX16055 hex voltage μ P supervisory circuit maintains system integrity in multisupply systems (Figure 1). The MAX16055 offers accurate, factory-fixed undervoltage threshold options for monitoring very low voltages. The MAX16055 also offers one to five adjustable thresholds for monitoring voltages down to 0.5V. See the *Selector Guide* for the available threshold options.

The MAX16055 includes an accurate voltage reference, precision comparators, and a series of accurate internal resistor-divider networks to set the factory-fixed reset threshold options for monitoring 3.3V, 3.0V, 2.5V, 1.8V, 1.5V, 1.2V, 1.1V, 1.0V, or 0.9V supplies. The resistor networks scale the specified IN_ threshold voltages to match the internal reference voltage. Adjustable threshold options allow the monitored voltage to be connected to the input of the internal comparator. Use an external voltage-divider to set the threshold voltage.

Ultra-Small, Hex Voltage, Microprocessor Supervisor

The MAX16055 is immune to short IN_ transients. Each of the internal comparators provides a typical hysteresis of 0.3% with respect to the reset threshold. This built-in hysteresis improves the monitor's immunity to ambient noise without significantly reducing threshold accuracy. See the *Typical Operating Characteristics* for a glitch immunity graph labeled Maximum IN_ Transient Duration vs. Reset Threshold Overdrive.

Reset Output

The MAX16055 $\overline{\text{RESET}}$ output asserts low when any monitored IN_ voltage drops below the specified reset threshold. $\overline{\text{RESET}}$ remains low for the reset timeout period of 140ms (min) after all inputs rise above the respective thresholds (Figure 2). The $\overline{\text{RESET}}$ output is open drain with a weak internal pullup to the monitored IN1 supply (70 μ A typ). For many applications, no external pullup resistor is required to interface with other logic devices. Apply an external pullup resistor to any voltage from 0 to 5.5V when interfacing to different logic-supply voltages (Figure 3). Internal circuitry prevents reverse current flow from the external pullup voltage into the $\overline{\text{RESET}}$ output when $\overline{\text{RESET}}$ is not asserted. $\overline{\text{RESET}}$ asserts low upon power-up. After all IN_ inputs rise above the respective threshold voltages, $\overline{\text{RESET}}$

remains low for the reset timeout period (Figure 4) before going high.

IN1 powers the MAX16055 and is also a monitored voltage. When any monitored supply drops below the threshold voltage, $\overline{\text{RESET}}$ asserts low and remains low while either IN1 or IN2 is above 1.0V.

Adjustable Thresholds

The MAX16055 includes monitor options with adjustable reset thresholds. The threshold voltage at each adjustable IN_ input is typically 0.5V. To monitor a voltage higher than 0.5V, connect a resistor-divider network to the circuit as shown in Figure 5:

$$V_{\text{INTH}} = 0.5V \times (R1 + R2)/R2$$

Therefore:

$$R1 = R2 ((V_{\text{INTH}}/0.5V) - 1)$$

Use high valued resistors (~ 100k Ω) to minimize current through the external resistors. Use lower valued resistors for greater accuracy. The MAX16055 includes an internal voltage clamp (1.5V typ) at each of the adjustable voltage inputs. An input voltage higher than 1.5V induces a higher input current.

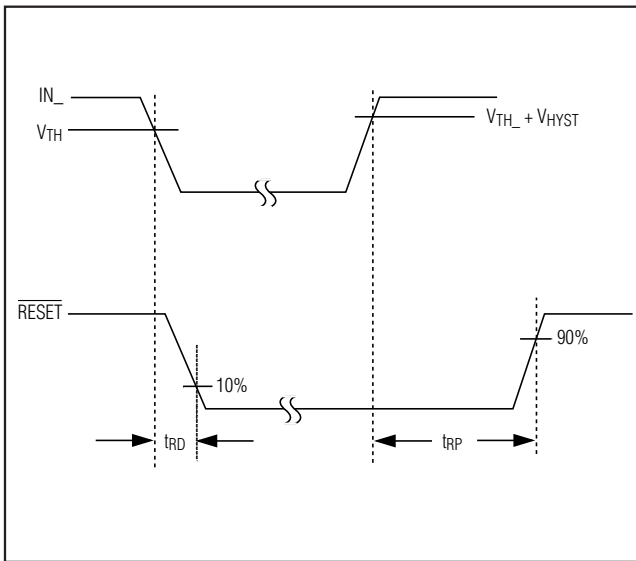

Figure 2. $\overline{\text{RESET}}$ Output Timing Diagram

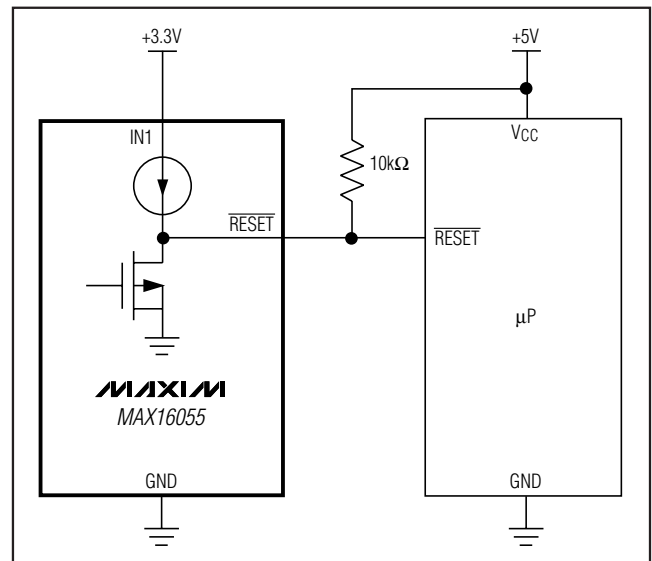

Figure 3. Interfacing with External Logic-Supply Voltage

Ultra-Small, Hex Voltage, Microprocessor Supervisor

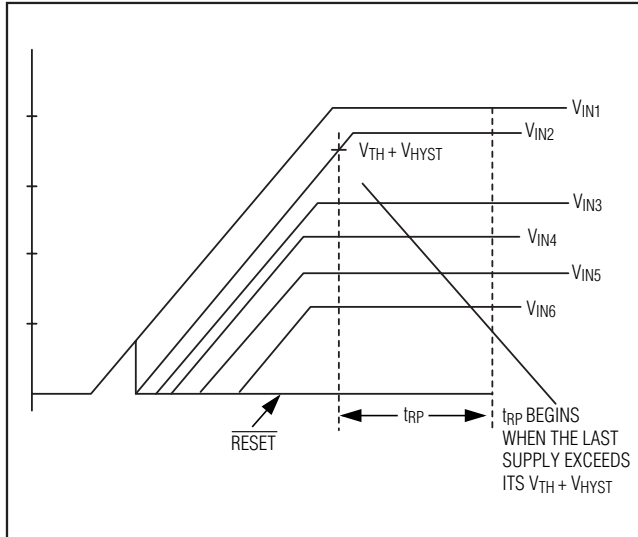

Figure 4. $\overline{\text{RESET}}$ Output with Various Input Voltages

Manual-Reset Input ($\overline{\text{MR}}$)

Many μP -based products require manual-reset capability. A logic-low on $\overline{\text{MR}}$ asserts $\overline{\text{RESET}}$ low. $\overline{\text{RESET}}$ remains asserted while $\overline{\text{MR}}$ is low, and during the reset timeout period (140ms, min) after $\overline{\text{MR}}$ returns high. The $\overline{\text{MR}}$ input has an internal 20k Ω pullup resistor to IN1. Connect a normally open momentary switch from $\overline{\text{MR}}$ to GND to create a manual-reset function. Connect a 0.1 μF capacitor from $\overline{\text{MR}}$ to GND to provide additional noise immunity when driving $\overline{\text{MR}}$ from long cables or when the device is used in a noisy environment.

Tolerance (TOL)

The MAX16055 features an adjustable threshold tolerance. Connect TOL to GND to set the threshold voltages 5% below the nominal value. Connect TOL to IN1 to set the threshold voltages 10% below the nominal value. See the *Electrical Characteristics* table. Do not leave TOL unconnected.

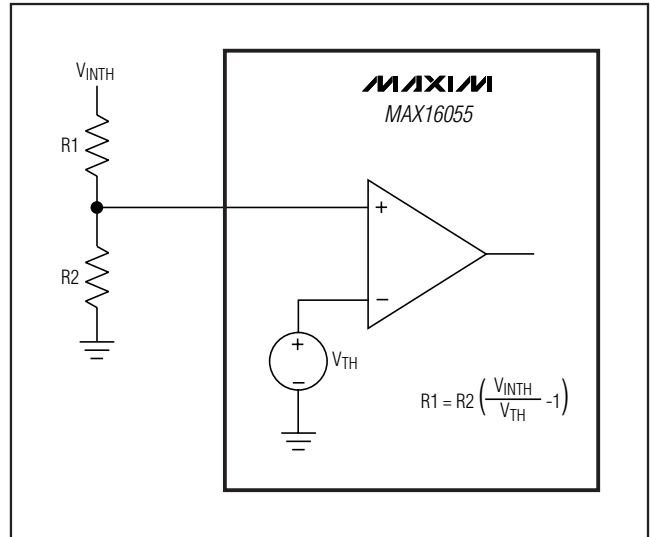

Figure 5. Setting the Adjustable Threshold

Applications Information

Unused Inputs

Connect unused monitor inputs to a supply voltage higher than the specified threshold voltage. Connect a 100k Ω resistor between an unused adjustable input and IN1 to limit the bias current. Use IN1 for normal operation (device power supply). Do not connect unused monitor inputs to ground. Do not leave unused monitor inputs unconnected.

Reset Output Pullup Resistor

When connecting a pullup resistor from $\overline{\text{RESET}}$ to a voltage rail lower than the voltage on IN1, the internal 70 μA pullup current flows through the pullup resistor, causing the voltage at $\overline{\text{RESET}}$ to be higher than the voltage rail when $\overline{\text{RESET}}$ is deasserted. Ensure that the value of the pullup resistor is low enough that the voltage rise does not cause problems.

Power-Supply Bypassing and Grounding

IN1 powers the MAX16055. Connect a 0.1 μF bypass capacitor from IN1 to ground. All monitored inputs are immune to short supply transients. Add bypass capacitors from IN2–IN6 to GND to improve noise immunity.

Ultra-Small, Hex Voltage, Microprocessor Supervisor

Selector Guide

MAX16055

PART* (SUFFIX IN BOLD)	NOMINAL INPUT VOLTAGE (V)					
	IN1	IN2	IN3	IN4	IN5	IN6
MAX16055 A	3.3	2.5	1.5	1.8	1.2	0.9
MAX16055 B	3.3	3.0	1.8	1.5	1.1	1.0
MAX16055 C	3.3	ADJ	ADJ	1.8	ADJ	ADJ
MAX16055 D	3.3	ADJ	1.5	ADJ	ADJ	ADJ
MAX16055 E	3.3	2.5	ADJ	1.8	ADJ	ADJ
MAX16055 F	3.3	2.5	1.5	ADJ	ADJ	ADJ
MAX16055 G	3.3	2.5	ADJ	ADJ	ADJ	ADJ
MAX16055 H	3.3	ADJ	ADJ	ADJ	ADJ	ADJ
MAX16055 I	2.5	ADJ	ADJ	ADJ	ADJ	ADJ
MAX16055 J	3.3	3.3	2.5	1.2	1.5	1.2

*Adjustable voltage is based on the 0.5V internal threshold. External threshold voltage can be set using an external resistor-divider. ($V_{ADJ} = 0.500V$ typ).

Chip Information

PROCESS: BiCMOS

Package Information

For the latest package outline information and land patterns, go to www.maxim-ic.com/packages.

PACKAGE TYPE	PACKAGE CODE	DOCUMENT NO.
10 μ MAX	U10+2	21-0061

Maxim cannot assume responsibility for use of any circuitry other than circuitry entirely embodied in a Maxim product. No circuit patent licenses are implied. Maxim reserves the right to change the circuitry and specifications without notice at any time.

Maxim Integrated Products, 120 San Gabriel Drive, Sunnyvale, CA 94086 408-737-7600 _____ 9

Компания «Океан Электроники» предлагает заключение долгосрочных отношений при поставках импортных электронных компонентов на взаимовыгодных условиях!

Наши преимущества:

- Поставка оригинальных импортных электронных компонентов напрямую с производств Америки, Европы и Азии, а так же с крупнейших складов мира;
- Широкая линейка поставок активных и пассивных импортных электронных компонентов (более 30 млн. наименований);
- Поставка сложных, дефицитных, либо снятых с производства позиций;
- Оперативные сроки поставки под заказ (от 5 рабочих дней);
- Экспресс доставка в любую точку России;
- Помощь Конструкторского Отдела и консультации квалифицированных инженеров;
- Техническая поддержка проекта, помощь в подборе аналогов, поставка прототипов;
- Поставка электронных компонентов под контролем ВП;
- Система менеджмента качества сертифицирована по Международному стандарту ISO 9001;
- При необходимости вся продукция военного и аэрокосмического назначения проходит испытания и сертификацию в лаборатории (по согласованию с заказчиком);
- Поставка специализированных компонентов военного и аэрокосмического уровня качества (Xilinx, Altera, Analog Devices, Intersil, Interpoint, Microsemi, Actel, Aeroflex, Peregrine, VPT, Syfer, Eurofarad, Texas Instruments, MS Kennedy, Miteq, Cobham, E2V, MA-COM, Hittite, Mini-Circuits, General Dynamics и др.);

Компания «Океан Электроники» является официальным дистрибьютором и эксклюзивным представителем в России одного из крупнейших производителей разъемов военного и аэрокосмического назначения «JONHON», а так же официальным дистрибьютором и эксклюзивным представителем в России производителя высокотехнологичных и надежных решений для передачи СВЧ сигналов «FORSTAR».



JONHON

«JONHON» (основан в 1970 г.)

Разъемы специального, военного и аэрокосмического назначения:

(Применяются в военной, авиационной, аэрокосмической, морской, железнодорожной, горно- и нефтедобывающей отраслях промышленности)

«FORSTAR» (основан в 1998 г.)

ВЧ соединители, коаксиальные кабели, кабельные сборки и микроволновые компоненты:

(Применяются в телекоммуникациях гражданского и специального назначения, в средствах связи, РЛС, а так же военной, авиационной и аэрокосмической отраслях промышленности).



Телефон: 8 (812) 309-75-97 (многоканальный)

Факс: 8 (812) 320-03-32

Электронная почта: ocean@oceanchips.ru

Web: <http://oceanchips.ru/>

Адрес: 198099, г. Санкт-Петербург, ул. Калинина, д. 2, корп. 4, лит. А