



Is Now Part of



ON Semiconductor®

To learn more about ON Semiconductor, please visit our website at
www.onsemi.com

Please note: As part of the Fairchild Semiconductor integration, some of the Fairchild orderable part numbers will need to change in order to meet ON Semiconductor's system requirements. Since the ON Semiconductor product management systems do not have the ability to manage part nomenclature that utilizes an underscore (_), the underscore (_) in the Fairchild part numbers will be changed to a dash (-). This document may contain device numbers with an underscore (_). Please check the ON Semiconductor website to verify the updated device numbers. The most current and up-to-date ordering information can be found at www.onsemi.com. Please email any questions regarding the system integration to Fairchild_questions@onsemi.com.

ON Semiconductor and the ON Semiconductor logo are trademarks of Semiconductor Components Industries, LLC dba ON Semiconductor or its subsidiaries in the United States and/or other countries. ON Semiconductor owns the rights to a number of patents, trademarks, copyrights, trade secrets, and other intellectual property. A listing of ON Semiconductor's product/patent coverage may be accessed at www.onsemi.com/site/pdf/Patent-Marking.pdf. ON Semiconductor reserves the right to make changes without further notice to any products herein. ON Semiconductor makes no warranty, representation or guarantee regarding the suitability of its products for any particular purpose, nor does ON Semiconductor assume any liability arising out of the application or use of any product or circuit, and specifically disclaims any and all liability, including without limitation special, consequential or incidental damages. Buyer is responsible for its products and applications using ON Semiconductor products, including compliance with all laws, regulations and safety requirements or standards, regardless of any support or applications information provided by ON Semiconductor. "Typical" parameters which may be provided in ON Semiconductor data sheets and/or specifications can and do vary in different applications and actual performance may vary over time. All operating parameters, including "Typicals" must be validated for each customer application by customer's technical experts. ON Semiconductor does not convey any license under its patent rights nor the rights of others. ON Semiconductor products are not designed, intended, or authorized for use as a critical component in life support systems or any FDA Class 3 medical devices or medical devices with a same or similar classification in a foreign jurisdiction or any devices intended for implantation in the human body. Should Buyer purchase or use ON Semiconductor products for any such unintended or unauthorized application, Buyer shall indemnify and hold ON Semiconductor and its officers, employees, subsidiaries, affiliates, and distributors harmless against all claims, costs, damages, and expenses, and reasonable attorney fees arising out of, directly or indirectly, any claim of personal injury or death associated with such unintended or unauthorized use, even if such claim alleges that ON Semiconductor was negligent regarding the design or manufacture of the part. ON Semiconductor is an Equal Opportunity/Affirmative Action Employer. This literature is subject to all applicable copyright laws and is not for resale in any manner.

FAN604

Offline Quasi-Resonant PWM Controller

The FAN604 is an advanced PWM controller aimed at achieving power density of $\geq 10\text{W}/\text{in}^3$ in universal input range AC/DC flyback isolated power supplies. It incorporates Quasi-Resonant (QR) control with proprietary Valley Switching with a limited frequency variation. QR switching provides high efficiency by reducing switching losses while Valley Switching with a limited frequency variation bounds the frequency band to overcome the inherent limitation of QR switching.

FAN604 features mWSaver® burst mode operation with extremely low operating current (300 μA) and significantly reduces standby power consumption to meet the most stringent efficiency regulations such as Energy Star's 5-Star Level and CoC Tier II specifications.

FAN604 includes several user configurable features aimed at optimizing efficiency, EMI and protections. FAN604 has a wide blanking frequency range that improves light load efficiency and eliminating audio noise for adaptive application. It incorporates user-configurable constant current reference, which allows controlling the maximum output current from primary-side, thereby optimizing transformer design to improve the overall efficiency. It also includes several rich programmable protection features such as over-voltage protection (OVP), precise constant output current regulation (CC).

Features

- Higher Average Efficiency by Quasi-Resonant Switching Operation with Wide Blanking Time Range
- Wide Input and Output Conditions Achieve High Power Density Power Supply
 - Optimization Transformer Design for Adaptive Charger Application
 - User Configurable Constant Current Reference (CCR) to Limit the Maximum Output Current
 - Precise Constant Output Current Regulation with Programmable Line Compensation
- mWSaver® Technology for Ultra Low Standby Power Consumption (<20 mW)
- Forced and Inherent Frequency Modulation of Valley Switching for Low EMI Emissions and Common Mode Noise
- Built-In and User Configurable Over-Voltage Protection (OVP), Under-Voltage Protection (UVP) and Over-Temperature Protection (OTP)
- Programmable Over-Temperature-Protection through External NTC Resistor
- Fully Programmable Brown-In and Brownout Protection
- Built-In High-Voltage Startup to Reduce External Components

Typical Applications

- Battery Charges for Smart Phones, Feature Phones, and Tablet PCs
- AC-DC Adapters for Portable Devices or Battery Chargers that Require CV/CC Control



ON Semiconductor®

www.onsemi.com

MARKING DIAGRAM

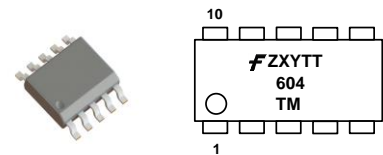

Z: Assembly Plant Code
X: Year Code
Y: Week Code
TT: Die Run Code
T: Package Type (M=SOIC)
M: Manufacture Flow Code

PIN CONNECTIONS

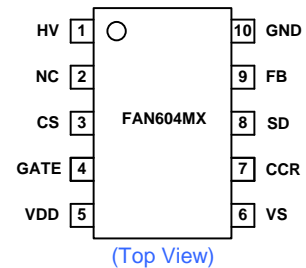

ORDERING INFORMATION

See detailed ordering and shipping information in the package dimensions section on page 20 of this data sheet.

FAN604

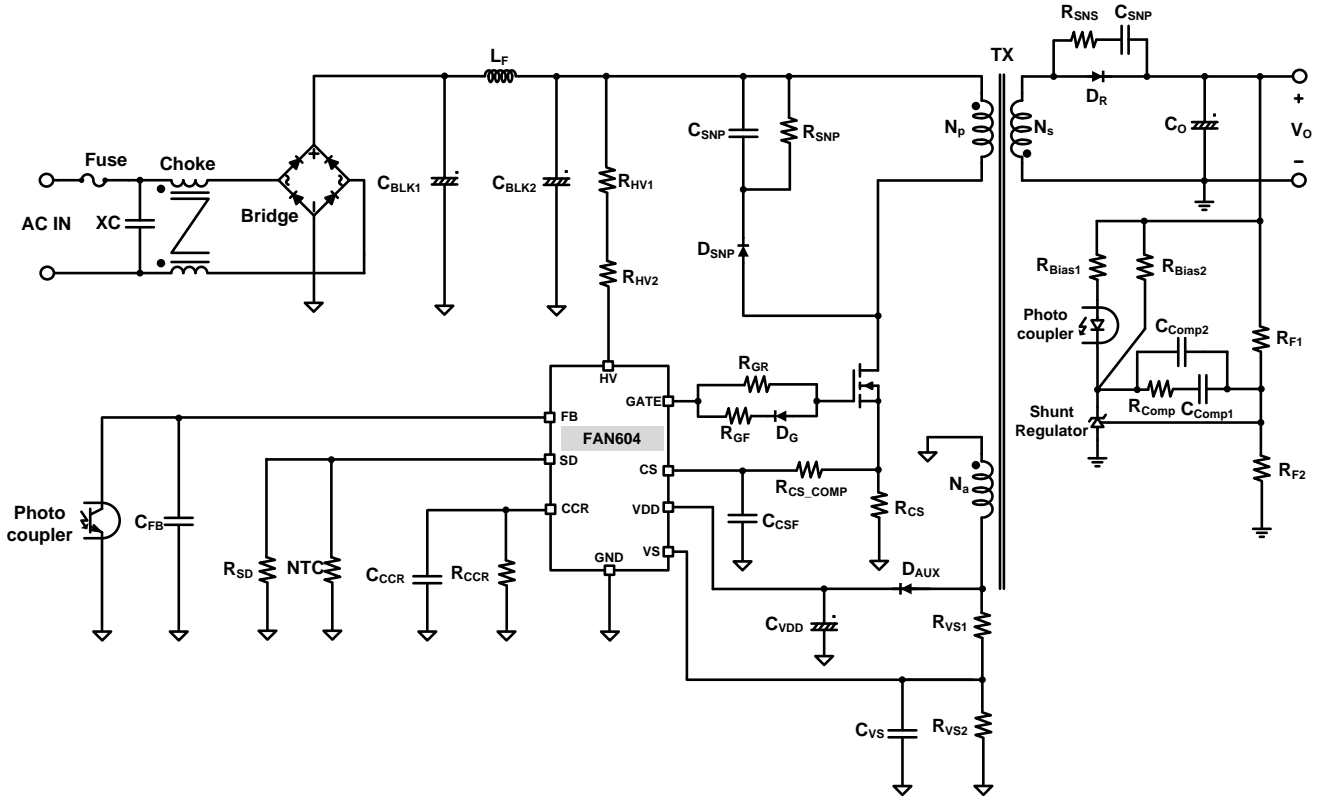

Figure 1 FAN604 Typical Application

FAN604

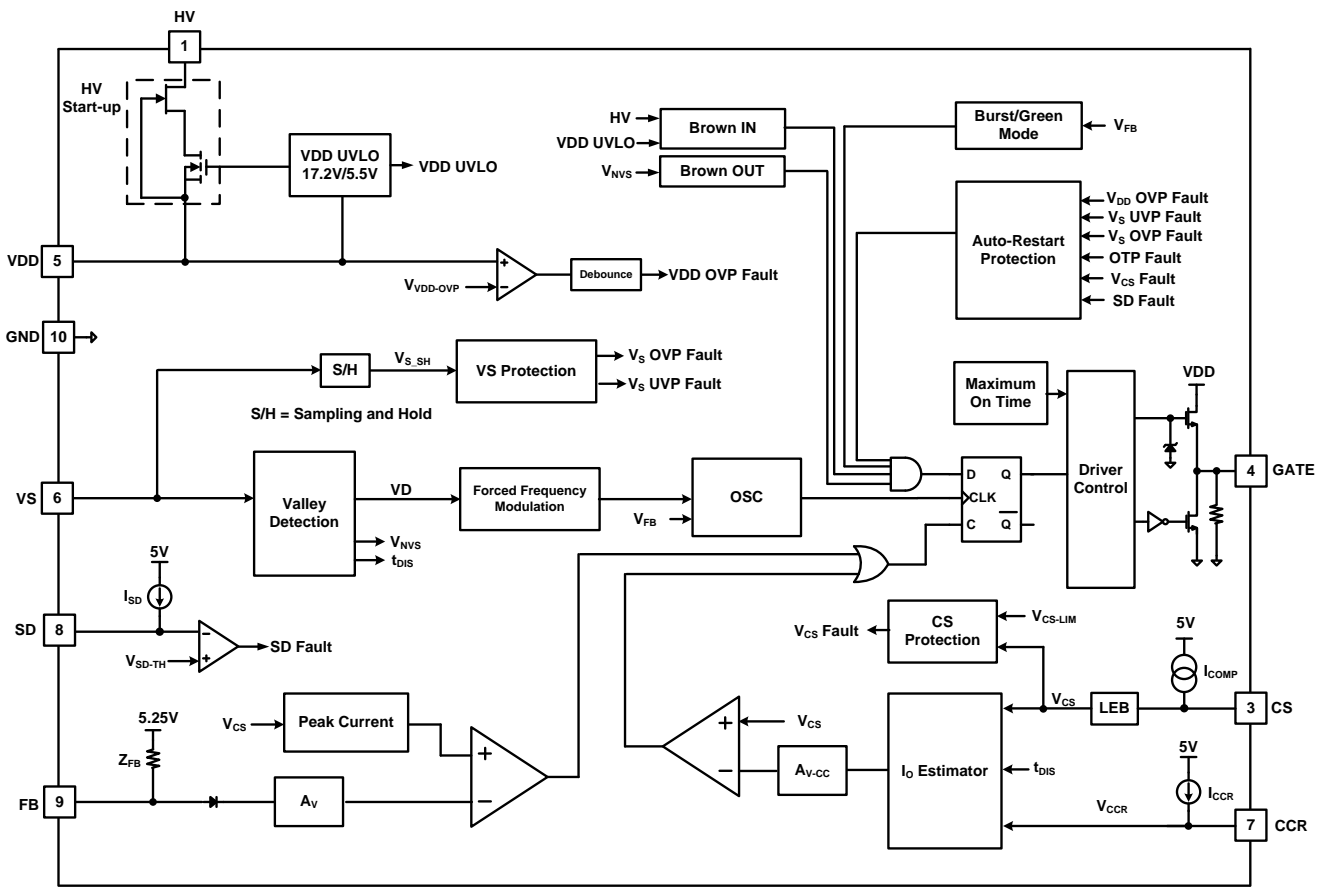

Figure 2 FAN604 Block Diagram

PIN FUNCTION DESCRIPTION

Pin No.	Pin Name	Description
1	HV	High Voltage. This pin connects to DC bus for high-voltage startup.
2	NC	No Connect.
3	CS	Current Sense. This pin connects to a current-sense resistor to sense the MOSFET current for Peak-Current-Mode control for output regulation. The current sense information is also used to estimate the output current for CC regulation.
4	GATE	PWM Signal Output. This pin has an internal totem-pole output driver to drive the power MOSFET. The gate driving voltage is internally clamped at 7.5V.
5	VDD	Power Supply. IC operating current and MOSFET driving current are supplied through this pin. This pin is typically connected to an external VDD capacitor.
6	VS	Voltage Sense. The VS voltage is used to detect resonant valleys for quasi-resonant switching. This pin detects the output voltage information and diode current discharge time based on the auxiliary winding voltage. It also senses input voltage for Brown-out protection.
7	CCR	Constant Current Reference. This pin connects to external resistor to program the reference voltage of constant output current.
8	SD	Shut Down. This pin is implemented for external over-temperature-protect by connecting NTC thermistor.
9	FB	Feedback. Typically Opto-Coupler is connected to this pin to provide feedback information to the internal PWM comparator. This feedback is used to control the duty cycle in CV regulation.
10	GND	Ground.

FAN604

MAXIMUM RATINGS

Rating	Symbol	Value	Unit
Maximum Voltage on HV Pin	V_{HV}	500	V
DC Supply Voltage	V_{VDD}	30	V
Maximum Voltage on GATE Pin	V_{GETE}	-0.3 to 30	V
Maximum Voltage on Low Power Pins (Except Pin 1, Pin 4, Pin 5)	V_{max}	-0.3 to 6	V
Power Dissipation ($T_A=25^{\circ}C$)	P_D	850	mW
Thermal Resistance (Junction-to-Ambient)	θ_{JA}	140	$^{\circ}C/W$
Thermal Resistance (Junction-to-Top)	Ψ_{JT}	13	$^{\circ}C/W$
Operating Junction Temperature	T_J	-40 to +150	$^{\circ}C$
Storage Temperature Range	T_{STG}	-40 to +150	$^{\circ}C$
Human Body Model, JEDEC:JESD22_A114 (Except HV Pin)	ESD	2.0	kV
Charged Device Model, JEDEC:JESD22_C101 (Except HV Pin)		0.75	

1. All voltage values, except differential voltages, are given with respect to GND pin.
2. Stresses beyond those listed under Absolute Maximum Ratings may cause permanent damage to the device.
3. ESD ratings including HV pin: HBM=2.0 kV, CDM=0.75kV.

RECOMMENDED OPERATING RANGES

Rating	Symbol	Min	Max	Unit
HV Pin Supply Voltage	V_{HV}	50	400	V
VDD Pin Supply Voltage	V_{VDD}	6	25	V
VS Pin Supply Voltage	V_{VS}	0.65	2.3	V
CS Pin Supply Voltage	V_{CS}	0	0.9	V
FB Pin Supply Voltage	V_{FB}	0	5.25	V
CCR Pin Supply Voltage	V_{CCR}	0.2	1.7	V
SD Pin Supply Voltage	V_{SD}	0	5	V
Operating Temperature	T_A	-40	+85	$^{\circ}C$

4. The Recommended Operating Conditions table defines the conditions for actual device operation. Recommended operating conditions are specified to ensure optimal performance. ON does not recommend exceeding them or designing to Absolute Maximum Ratings.

FAN604

ELECTRICAL CHARACTERISTICS

For typical values $T_J = 25^\circ\text{C}$, for min/max values $T_J = -40^\circ\text{C}$ to 125°C , $V_{DD} = 15\text{ V}$; unless otherwise noted.

Parameter	Test Conditions	Symbol	Min	Typ	Max	Unit
-----------	-----------------	--------	-----	-----	-----	------

HV Section

Supply Current Drawn from HV Pin	$V_{HV}=120\text{ V}$, $V_{DD}=0\text{ V}$	I_{HV}	1.2	2.0	10	mA
Leakage Current Drawn from HV Pin	$V_{HV}=500\text{ V}$, $V_{DD}=V_{DD-OFF}+1\text{ V}$	I_{HV-LC}	0	0.8	10	μA
Brown-In Threshold Voltage	$R_{HV}=150\text{k}\Omega$, $V_{IN}=80V_{AC}$	$V_{Brown-IN}$	100	110	120	V

V_{DD} Section

Turn-On Threshold Voltage	V_{DD} Rising	V_{DD-ON}	15.3	17.2	18.7	V
Turn-Off Threshold Voltage	V_{DD} Falling	V_{DD-OFF}	5.0	5.5	5.7	V
Threshold Voltage for HV Startup	$T_J = 25^\circ\text{C}$	$V_{DD-HV-ON}$	4.1	4.7	5.4	V
Startup Current	$V_{DD}=V_{DD-ON}-0.16\text{ V}$	I_{DD-ST}	-	300	450	μA
Operating Supply Current	$V_{CS}=5.0\text{ V}$, $V_{VS}=3\text{ V}$, $V_{FB}=3\text{ V}$ $C_{GATE}=1\text{nF}$	I_{DD-OP}	-	2	3	mA
Burst-Mode Operating Supply Current	$V_{CS}=0.3\text{ V}$, $V_{VS}=0\text{ V}$, $V_{FB}=0\text{ V}$; $V_{DD}=V_{DD-ON}\rightarrow V_{DD-OVP}\rightarrow 10\text{ V}$, $C_{GATE}=1\text{nF}$	$I_{DD-Burst}$	-	300	600	μA
V_{DD} Over-Voltage-Protection Level	$T_J = 25^\circ\text{C}$	$V_{VDD-OVP}$	27.5	29.0	29.5	V
V_{DD} Over-Voltage-Protection Debounce Time		$t_{D-VDDOVP}$	-	70	105	μs

Oscillator Section

Maximum Blanking Frequency	$V_{FB} > V_{FB-BNK-H}$	$f_{BNK-MAX}$	125	130	135	kHz
Minimum Blanking Frequency	$V_{FB} < V_{FB-BNK-L}$	$f_{BNK-MIN}$	16.5	18.5	20.5	kHz
Minimum Frequency	$V_{VS} = 1\text{ V}$	$f_{OSC-MIN}$	15	17	19	kHz
Forced Frequency Modulation Range	$V_{FB} > V_{FB-Burst-H}$	$\Delta t_{FM-Range}$	210	265	310	ns
Forced Frequency Modulation Period		$\Delta t_{FM-Period}$	2.1	2.5	2.9	ms

Feedback Input Section

FB Pin Input Impedance		Z_{FB}	39	42	45	k Ω
Internal Voltage Attenuator of FB Pin (Note 5)		A_V	1/3	1/3.5	1/4	V/V
FB Pin Pull-Up Voltage	FB Pin Open	$V_{FB-Open}$	4.55	5.25	5.90	V
Frequency Foldback Starting/Stopping VFB	$T_J = 25^\circ\text{C}$	$V_{FB-BNK-H}$	2.10	2.25	2.40	V
	$T_J = 25^\circ\text{C}$	$V_{FB-BNK-L}$	1.10	1.25	1.40	V
FB Threshold to Enable/Disable Gate Drive in Burst Mode	V_{FB} Rising	$V_{FB-Burst-H}$	0.65	0.75	0.85	V
	V_{FB} Falling	$V_{FB-Burst-L}$	0.60	0.70	0.80	V

FAN604

ELECTRICAL CHARACTERISTICS (CONTINUED)

For typical values $T_J = 25^\circ\text{C}$, for min/max values $T_J = -40^\circ\text{C}$ to 125°C , $V_{DD} = 15\text{V}$; unless otherwise noted.

Parameter	Test Conditions	Symbol	Min	Typ	Max	Unit
-----------	-----------------	--------	-----	-----	-----	------

Voltage-Sense Section

Maximum VS Source Current Capability		I_{VS-MAX}	-	-	3	mA
VS Sampling Blanking Time 1 after GATE Pin Pull-Low	V_{FB} Falling and $V_{FB} < 2.0\text{V}$	$t_{VS-BNK1}$	0.84	1.0	1.23	μs
VS Sampling Blanking Time 2 after GATE Pin Pull-Low	V_{FB} Rising and $V_{FB} > 2.2\text{V}$	$t_{VS-BNK2}$	1.45	1.8	2.15	μs
Delay from VS Voltage Zero Crossing to PWM ON (Note 5)	$V_{VS}=0\text{V}$, $C_{GATE}=1\text{nF}$	$t_{ZCD-to PWM}$		175		ns
VS Source Current Threshold to Enable Brown-out		$I_{VS-Brown-Out}$	360	450	530	μA
Brown-Out Debounce Time		$t_{D-Brown-Out}$	12.5	16.5	21	ms
Output Over-Voltage-Protection with Vs Sampling Voltage		V_{VS-OVP}	2.2	2.3	2.4	V
Output Over-Voltage-Protection Debounce Pulse Counts		N_{VS-OVP}	-	2	-	Pulse
Output Under-Voltage-Protection with Vs Sampling Voltage	$T_J = 25^\circ\text{C}$	V_{VS-UVS}	0.625	0.650	0.675	V
Output Over-Voltage-Protection Debounce Pulse Counts		N_{VS-UVS}	-	2	-	Pulse
Output Under-Voltage Protection Blanking Time at start-up		$t_{VS-UVS-BLANK}$	25	40	55	ms
Auto-Restart Cycle Counts when Extend Auto-Restart Mode is triggered	$V_{VS} < V_{VS-UVS}$	$N_{VDD-Hiccup}$	-	2	-	Cycle

Over-Temperature Protection Section

Threshold Temperature for Over-Temperature-Protection (Note 5)		T_{OTP}	-	140	-	$^\circ\text{C}$
--	--	-----------	---	-----	---	------------------

Current-Sense Section

Current Limit Threshold Voltage	FB Pin Open	V_{CS-LIM}	0.865	0.890	0.915	V
High Threshold Voltage of Current Sense	$V_{FB} > V_{FB-BNK-L}$	$V_{CS-IMIN-H}$	0.39	0.44	0.51	V
Middle Threshold Voltage of Current Sense	$V_{FB} = 1\text{V}$, $T_J = 25^\circ\text{C}$	$V_{CS-IMIN-M}$	0.30	0.35	0.40	V
Low Threshold Voltage of Current Sense	$V_{FB} < V_{FB-Burst-H}$, $T_J = 25^\circ\text{C}$	$V_{CS-IMIN-L}$	0.21	0.25	0.29	V
GATE Output Turn-Off Delay (Note 5)		t_{PD}	-	50	100	ns
Leading-Edge Blanking Time (Note 5)		t_{LEB}	-	150	200	ns

FAN604

ELECTRICAL CHARACTERISTICS (CONTINUED)

For typical values $T_J = 25^\circ\text{C}$, for min/max values $T_J = -40^\circ\text{C}$ to 125°C , $V_{DD} = 15\text{ V}$; unless otherwise noted.

Parameter	Test Conditions	Symbol	Min	Typ	Max	Unit
-----------	-----------------	--------	-----	-----	-----	------

Shut-Down Function Section

SD Pin Source Current		I_{SD}	90	103	110	μA
Threshold Voltage for Shut-Down Function Enable		V_{SD-TH}	0.95	1.00	1.05	V
Debounce Time for Shut-Down Function		t_{D-SD}	200	400	600	μs
Ratio between threshold voltage and source current		Z_{SD-TH}	8.5	10	11	$\text{k}\Omega$
Hysteresis of Threshold Voltage for Shut-Down Function Enable		$V_{SD-TH-ST}$	1.30	1.35	1.40	V
Duration of $V_{SD-TH-ST}$ at startup		t_{SD-ST}	0.4	1.0	1.6	ms

Constant Current Correction Section

High Line Compensation Current	$V_{IN} = 264\text{ V}_{rms}$	I_{COMP-H}	90	100	110	μA
Low Line Compensation Current	$V_{IN} = 90\text{ V}_{rms}$	I_{COMP-L}	32	36	40	μA

Constant Current Estimator Section

CCR Pin Source Current		I_{CCR}	18.2	20	21.8	μA
Constant Current Control Reference Offset Voltage (Note 5)		$V_{REF_CC_Offset}$		0.8		V
Peak Value Amplifying Gain (Note 5)		A_{PK}		3.6		V/V
FB CC Pull-Up Voltage CC (Note 5)		$V_{FB-CC-Open}$		4.0		V
Internal Voltage Attenuator of FB CC (Note 5)		A_{V-CC}		0.444		V/V

GATE Section

Gate Output Voltage Low		V_{GATE-L}	0	-	1.5	V
Internal Gate PMOS Driver ON	V_{DD} Falling	$V_{DD-PMOS-ON}$	7.0	7.5	8.0	V
Internal Gate PMOS Driver OFF	V_{DD} Rising	$V_{DD-PMOS-OFF}$	9.0	9.5	10.0	V
Rising Time	$V_{CS}=0\text{ V}$, $V_S=0\text{ V}$, $C_{GATE}=1\text{ nF}$	t_r	100	135	180	ns
Falling Time	$V_{CS}=0\text{ V}$, $V_S=0\text{ V}$, $C_{GATE}=1\text{ nF}$ $T_J = 25^\circ\text{C}$	t_f	30	50	70	ns
Gate Output Clamping Voltage	$V_{DD}=25\text{ V}$	$V_{GATE-CLAMP}$	6.8	7.5	8.2	V
Maximum On Time	$V_{FB}=3\text{ V}$, $V_{CS}=0.3\text{ V}$	t_{ON-MAX}	20	22	25	μs

5. Design guaranteed.

TYPICAL CHARACTERISTICS

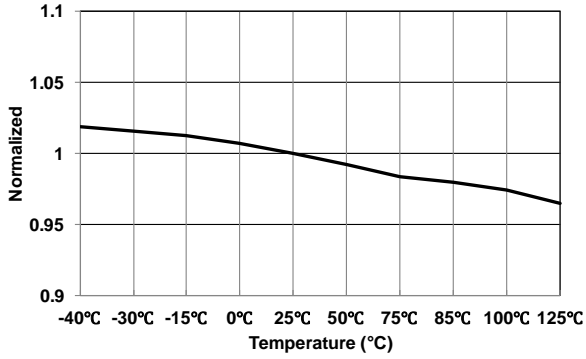

Figure 3 Turn-On Threshold Voltage (V_{DD-ON}) vs. Temperature

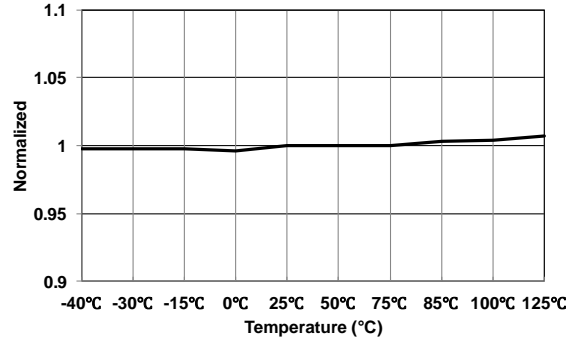

Figure 4 Turn-Off Threshold Voltage (V_{DD-OFF}) vs. Temperature

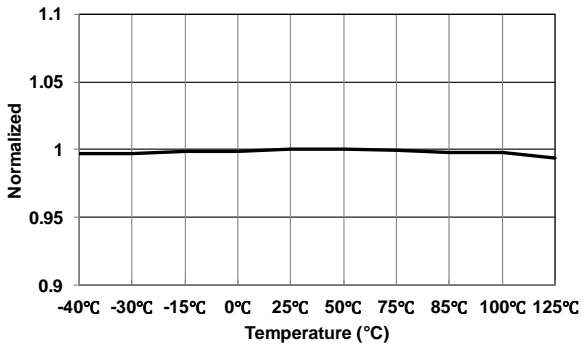

Figure 5 V_{DD} Over Voltage-Protection Level (V_{VDD-OVP}) vs. Temperature

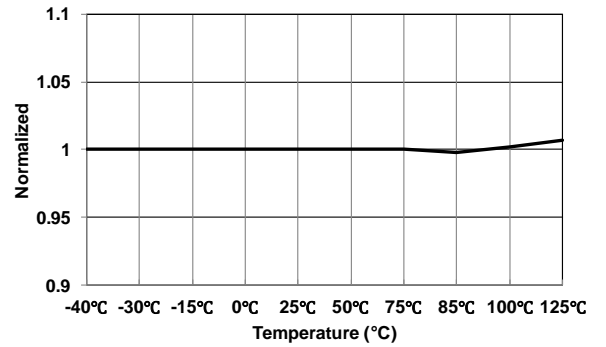

Figure 6 Brown-In Threshold Voltage (V_{Brown-IN}) vs. Temperature

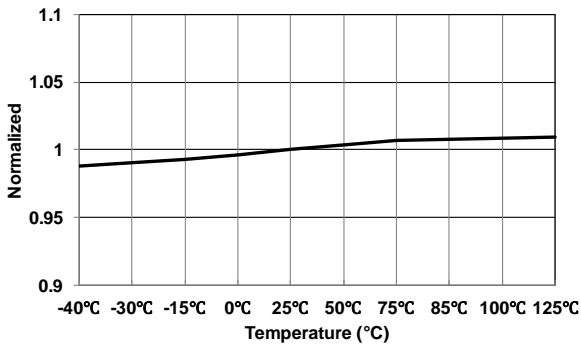

Figure 7 Maximum Blanking Frequency (f_{BNK-MAX}) vs. Temperature

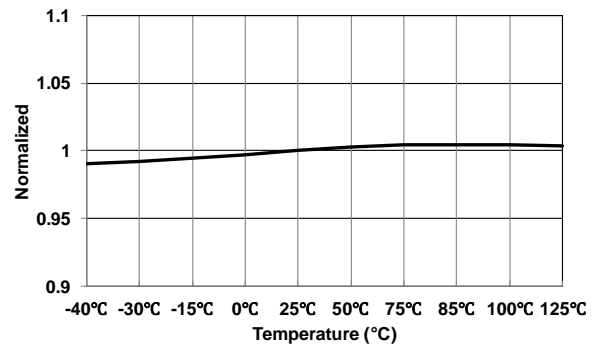
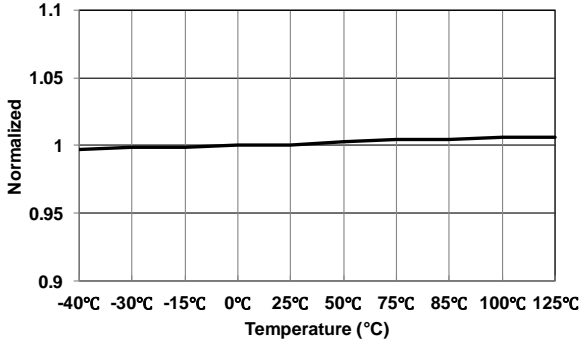
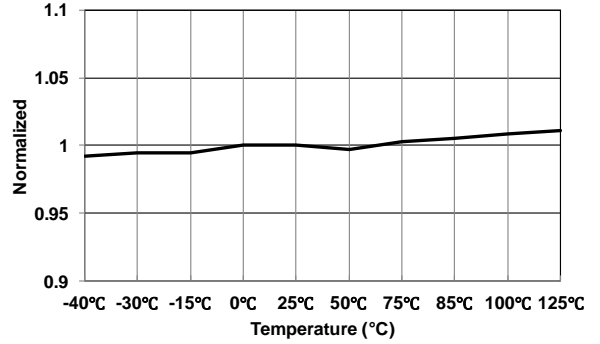

Figure 8 Minimum Blanking Frequency (f_{BNK-MIN}) vs. Temperature



**Figure 9 Frequency Foldback Starting VFB
($V_{FB-BNK-H}$) vs. Temperature**



**Figure 10 Frequency Foldback Stopping VFB
($V_{FB-BNK-L}$) vs. Temperature**

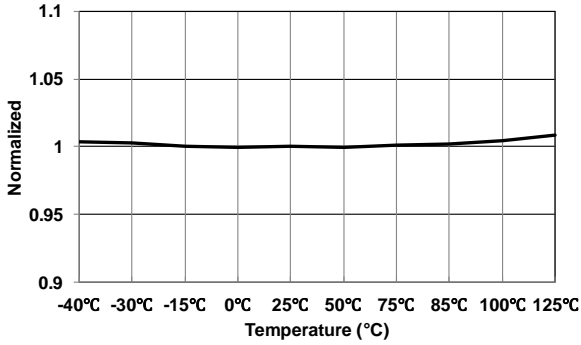

**Figure 11 VS Sampling Blanking Time 1
($t_{VS-BNK1}$) vs. Temperature**

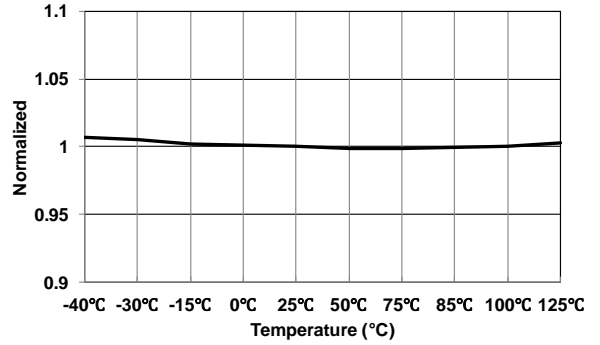

**Figure 12 VS Sampling Blanking Time 2
($t_{VS-BNK2}$) vs. Temperature**

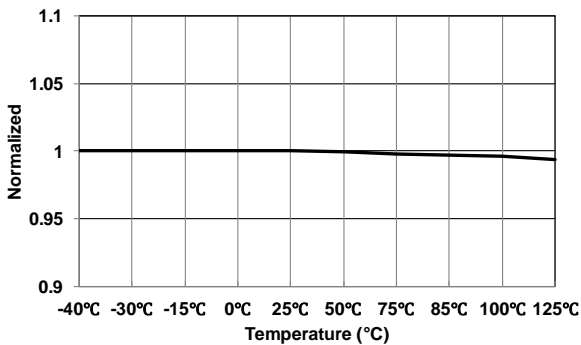

**Figure 13 Output Over-Voltage-Protection
(V_{VS-OVP}) vs. Temperature**

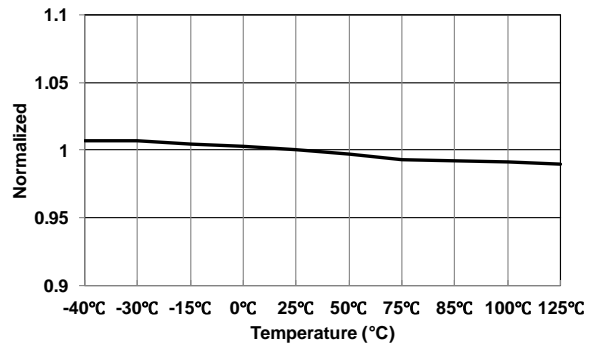

**Figure 14 Output Under-Voltage Protection
(V_{VS-UVP}) vs. Temperature**

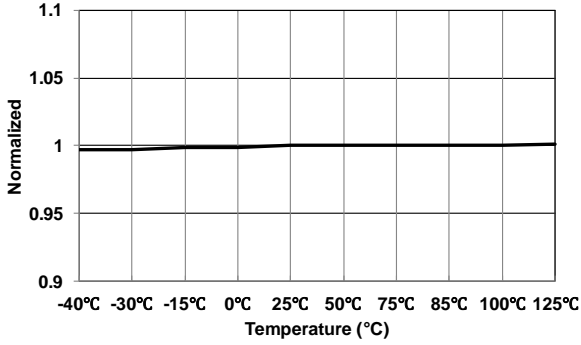

Figure 15 Current Limit Threshold Voltage (V_{CS-LIM}) vs. Temperature

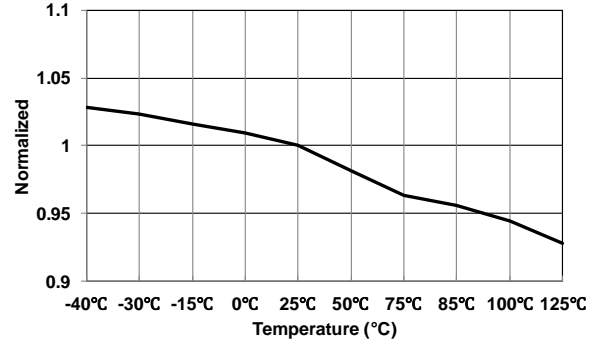

Figure 16 High Threshold Voltage of Current Sense ($V_{CS-IMIN-H}$) vs. Temperature

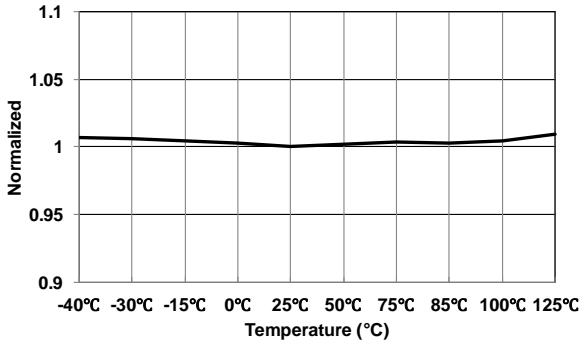

Figure 17 Ratio between Threshold Voltage and Source Current (Z_{SD-TH}) vs. Temperature

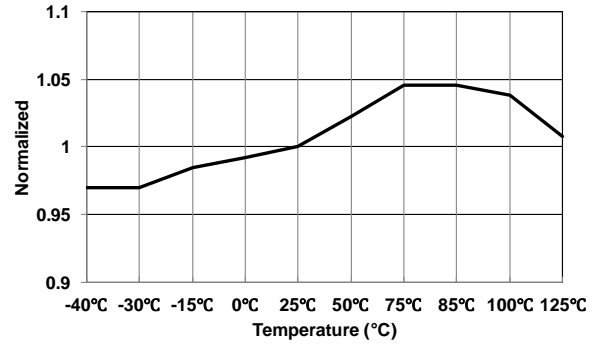

Figure 18 During of $V_{SD-TH-ST}$ at startup (t_{SD-ST}) vs. Temperature

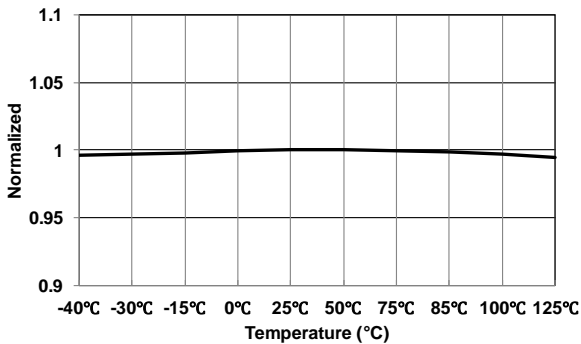

Figure 19 CCR Pin Source Current (I_{CCR}) vs. Temperature

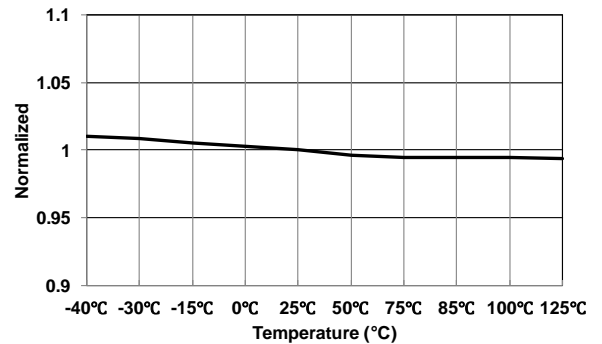

Figure 20 Maximum On Time (t_{ON-MAX}) vs. Temperature

APPLICATIONS INFORMATION

FAN604 is an offline PWM controller which operates in a quasi-resonant (QR) mode and significantly enhances system efficiency and power density. Its control method is based on the load condition (valley switching with fixed blanking time at heavy load and valley switching with variable blanking time at medium load) to maximize the efficiency. It offers constant output voltage (CV) regulation through opto-coupler feedback circuitry.

Line voltage compensation gain can be programmed by using an external resistor to minimize the effect of line voltage variation on output current regulation due to turn-off delay of the gate drive circuit.

FAN604 incorporates HV startup and accurate brown-in through HV pin. The brown-in voltage is programmed by using an external HV pin resistor. The constant current regulation (CCR), which sets the maximum output current level, is programmable via an external resistor connected to the CCR pin.

Protections such as V_{DD} Over-Voltage Protection (V_{DD} OVP), V_S Over-Voltage Protection (V_S OVP), V_S Under-Voltage Protection (V_S UVP), internal Over-Temperature Protection (OTP), Brownout protection and externally triggered shut-down (SD) function improve reliability.

Basic Operation Principle

Quasi-resonant switching is a method to reduce primary MOSFET switching losses low line is more effective. In order to perform QR turn-on of the primary MOSFET, the valley of the resonance occurring between transformer magnetizing inductance (L_m) and MOSFET effective output capacitance (C_{OSS-eff}) must be detected.

$$C_{OSS-eff} = C_{OSS-MOSFET} + C_{trans} + C_{parasitic} \quad (eq. 1)$$

$$t_{resonance} = 2\pi \sqrt{L_m \cdot C_{OSS-eff}} \quad (eq. 2)$$

For heavy load condition (50%~100% of full load), the blanking time for the valley detection is fixed such that the switching time is between 1/f_{BNK-MAX} and 1/f_{BNK-MAX} + t_{resonance} and primary side peak current will be modulated by voltage level of feedback. For the medium load condition (25%~50% of full load), the blanking time is modulated as a function of load current such that the

upper limit of the blanking frequency varies from f_{BNK-MAX} as load decreases where the blanking frequency reduction stop point is f_{BNK-MIN}. For the light load condition (5%~25%), the blanking time for the valley detection is fixed such that the switching time is between f_{BNK-MIN} and f_{BNK-MIN} + t_{resonance} and primary side peak current will be modulated by the function of V_{CS-IMIN} modulation, as shown in Figure 22

Burst Mode Operation

Figure 21 shows when V_{FB} drops below V_{FB-Burst-L}, the PWM output shuts off and the output voltage drops at a rate which is depended on the load current level. This causes the feedback voltage to rise. Once V_{FB} exceeds V_{FB-Burst-H}, FAN604 resumes switching. When the FB voltage drops below the corresponding V_{CS-IMIN-L}, the peak currents in switching cycles are limited by V_{CS-IMIN-L} regardless of FB voltage. Thus, more power is delivered to the load than required and once FB voltage is pulled low below V_{FB-Burst-L}, switching stops again. In this manner, the burst mode operation alternately enables and disables switching of the MOSFET to reduce the switching losses.

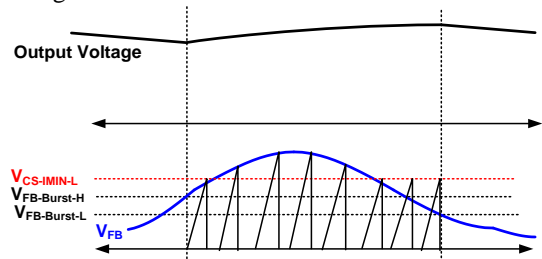

Figure 21 Burst-Mode Operation

Deep Burst Mode

FAN604 enters deep burst mode if FB voltage stays lower than V_{FB-Burst-L} for more than t_{Deep-Burst-Entry} (640 μs). Once FAN604 enters deep burst mode, the operating current is reduced to I_{DD-Burst} (300 μA) to minimize power consumption. Once feedback voltage is more than V_{FB-Burst-H}, power-on-reset occurs within a time period of t_{Deep-Burst-Exit} (25 μs) and IC resumes switching with normal operating current, I_{DD-OP}.

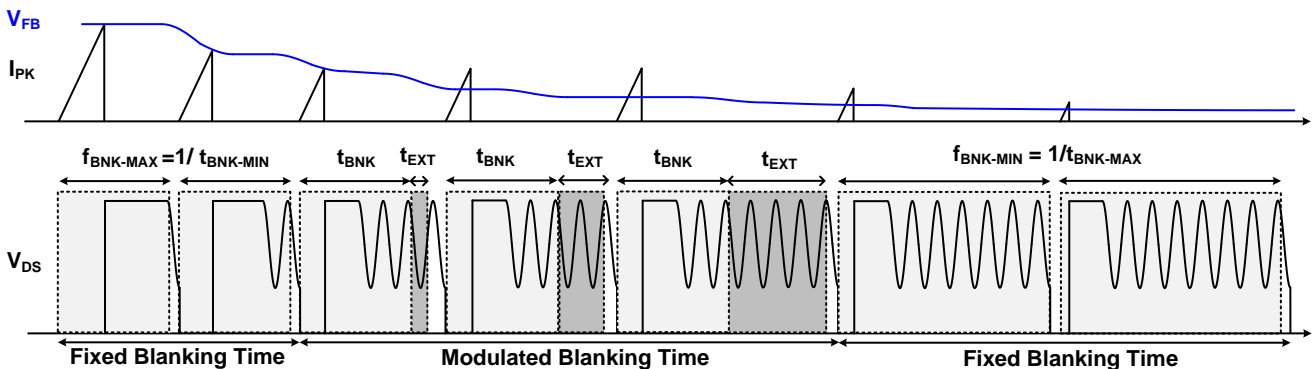

Figure 22 Frequency Fold-back Function

Valley Detection

There will be a logic propagation delay from VS Zero-Crossing Detection (V_{S-ZCD}) to IC GATE turn on and a MOSFET gate drives propagation delay from GATE pin to MOSFET turn on. We can assume the sum of these propagation delays to be $t_{ZCD-to-PWM}$ (175ns), as shown in Figure 23. However, if $1/2 t_F$ is longer than $t_{ZCD-to-PWM}$, the switching occurs away from the valley causing higher losses. The time period of resonant ringing is dependent on L_m and $C_{oss-eff}$. Typically, the time period of resonance ringing is around 1~1.5 μs depending on the system parameters. Hence, the switching may occur at a point different from the valley depending on the system. When PCB layout is poor, it may cause noise on the VS pin. The VS pin needs to be in parallel with the capacitor (C_{VS}) less than 10 pF to filter the noise.

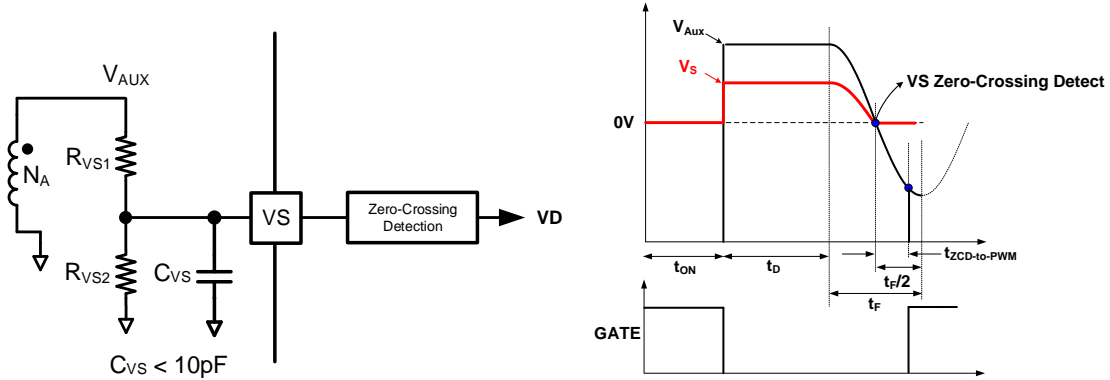

Figure 23 The Valley Detection Circuit and Behavior

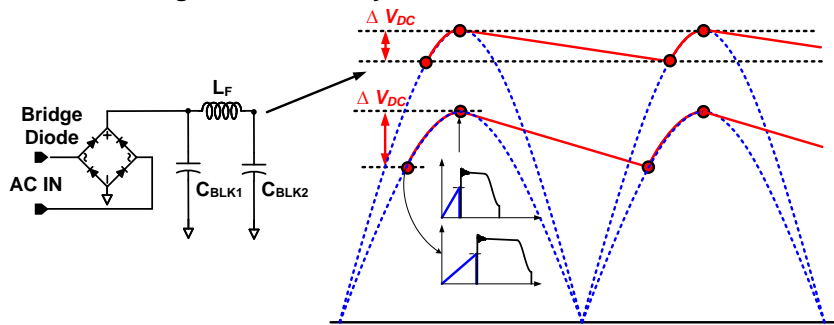

Figure 24 Inherent Frequency Modulation

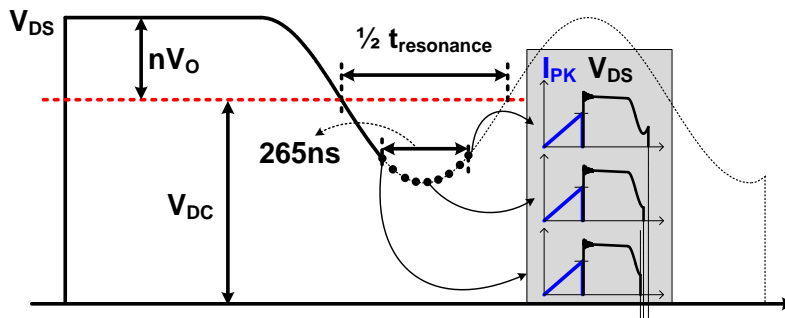

Figure 25 Forced Frequency Modulation

Inherent and Forced Frequency Modulation

Typically, the bulk capacitor of flyback converter has a longer charging time in low line than in high line. Thus, the voltage ripple (ΔV_{DC}) in low line is higher as shown in Figure 24. This large ripple results in 4~6% variation of the switching frequency in low line for a valley switched converter, the switching frequency could vary accordingly. This frequency variation scatters EMI noise nearby frequency band, this is helpful to meet EMI requirement easily. Hence, the EMI performance in low line is satisfied. However, in high line, the ripple is very small and consequently the EMI performance for high line may suffer. In order to maintain good EMI performance for high line, forced frequency modulation is provided. FAN604 varies the valley switching point from 0 to $\Delta t_{FM-Range}$ (265 ns) in every $\Delta t_{FM-Period}$ (2.5 ms) as shown in Figure 25. Since the drain voltage at which the switching occurs does not change much with this variation, there is minimum impact on the efficiency.

Output Voltage Detection

Figure 26 shows the VS voltage is sampled (V_{S-SH}) after t_{VS-BNK} of GATE turn-off so that the ringing does not introduce any error in the sampling. FAN604 dynamically varies t_{VS-BNK} with load. At heavy load, $t_{VS-BNK} = t_{VS-BNK1}$ ($1.8 \mu s$) when $V_{FB} > V_{FB-BNK-H}$. At light-load, $t_{VS-BNK} = t_{VS-BNK2}$ ($1.0 \mu s$) when $V_{FB} < V_{FB-BNK-L}$. This dynamic variation ensures that VS sampling occurs after ringing due to leakage inductance has stopped and before secondary current goes to zero.

$$V_{S-SH} = V_o \frac{N_A}{N_S} \frac{R_{VS2}}{R_{VS1} + R_{VS2}} \quad (\text{eq. 3})$$

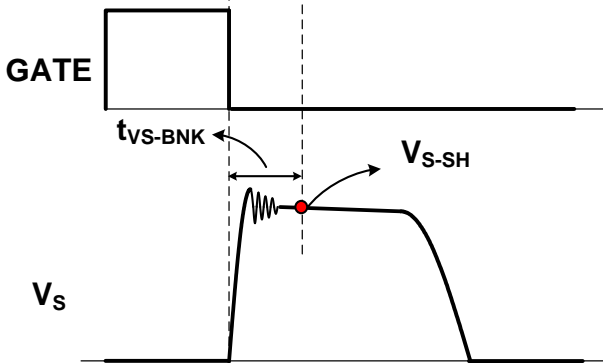

Figure 26 Output Voltage Detection

Line Voltage Detection

The FAN604 indirectly senses the line voltage through the VS pin while the MOSFET is turned on, as illustrated in Figure 27. During MOSFET turn-on period, the auxiliary winding voltage, V_{AUX} , is proportional to the input bulk capacitor voltage, V_{BLK} , due to the transformer coupling between the primary and auxiliary windings. During the MOSFET conduction time, the line voltage detector clamps the VS pin voltage to $V_{S-Clamp}$ ($0 V$), and then the current I_{VS} flowing out of VS pin is expressed as:

$$I_{VS} = \frac{V_{BLK} N_A}{R_{VS1} N_P} \quad (\text{eq. 4})$$

The I_{VS} current, reflecting the line voltage information, is used for brownout protection and CC control correction weighting.

CV / CC PWM Operation Principle

Figure 27 shows a simplified CV / CC PWM control circuit of the FAN604. The Constant Voltage (CV) regulation is implemented in the same manner as the conventional isolated power supply, where the output voltage is sensed using a voltage divider and compared with the internal reference of the shunt regulator to generate a compensation signal. The compensation signal is transferred to the primary side through an opto-coupler and scaled down by attenuator A_V to generate a COMV signal. This COMV signal is applied to the PWM comparator to determine the duty cycle.

The Constant Current (CC) regulation is implemented internally with primary-side control. The output current estimator calculates the output current using the transformer primary-side current and diode current discharge time. By comparing the estimated output current with internal reference signal, a COMI signal is generated to determine the duty cycle.

These two control signals, COMV and COMI, are compared with an internal sawtooth waveform (V_{SAW}) by two PWM comparators to determine the duty cycle. Figure 27 illustrates the outputs of two comparators, combined with an OR gate, to determine the MOSFET turn-off instant. Either of COMV or COMI, the lower signal determines the duty cycle. During CV regulation, COMV determines the duty cycle while COMI is saturated to HIGH level. During CC regulation, COMI determines the duty cycle while COMV is saturated to HIGH level.

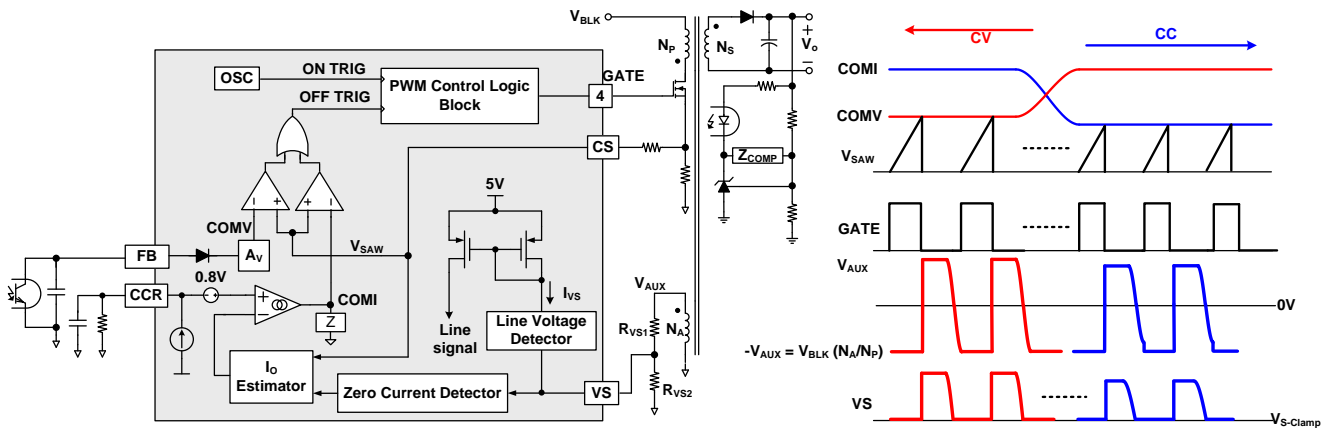

Figure 27 Simplified PWM Control Circuit and PWM Operation for CV/CC Regulation

Primary-Side Constant Current Operation

Figure 28 shows the key waveforms of a flyback converter operation in DCM. The output current is estimated by calculating the average of output diode current in one switching cycle:

$$I_O = \frac{1}{2} \frac{1}{R_{CS}} \frac{V_{CS-PK} \cdot T_{dis}}{T_S} \frac{N_P}{N_S} E_{ff} = \frac{1}{2} \frac{1}{R_{CS}} \frac{V_{REF_CC}}{A_{PK}} \frac{N_P}{N_S} E_{ff} \quad (eq. 5)$$

When the diode current reaches zero, the transformer winding voltage begins to drop sharply and VS pin voltage drops as well. When VS pin voltage drops below the VS-SH by more than 500 mV, zero current detection of diode current is obtained. The output current can be programmed by setting the resistor as of CCR:

$$R_{CCR} = \frac{1}{I_{CCR}} (2 \cdot I_O \cdot R_{CS} \cdot A_{PK} \cdot \frac{N_S}{N_P} \cdot \frac{1}{E_{ff}} - V_{REF_CC_Offset}) \quad (eq. 6)$$

When PCB layout is poor, it may cause noise on the CCR pin. The CCR pin needs to be in parallel with the capacitor (C_{CCR}) less than 4.7nF stabilizing the voltage against noise.

Line Voltage Compensation

The output current estimation is also affected by the turn-off delay of the MOSFET as illustrated in Figure 29. The actual MOSFET's turn-off time is delayed due to the MOSFET gate charge and gate driver's capability, resulting in peak current detection error as

$$\Delta I_{DS}^{PK} = \frac{V_{BLK}}{L_m} t_{OFF_DLY} \quad (eq. 7)$$

Where L_m is the transformer's primary side magnetizing inductance. Since the output current error is proportional to the line voltage, the FAN604 incorporates line voltage compensation to improve output current estimation accuracy. Line information is obtained through the line voltage detector as shown in Figure 27. I_{COMP} is an internal current source, which is proportional to line voltage. The line compensation gain is programmed by using CS pin series resistor, R_{CS_COMP}, depending on the MOSFET turn-off delay, t_{OFF_DLY}. I_{COMP} creates a voltage drop, V_{OFFSET}, across R_{CS_COMP}. This line compensation offset is proportional to the DC link capacitor voltage, V_{BLK}, and turn-off delay, t_{OFF_DLY}. Figure 29 demonstrates the effect of the line compensation.

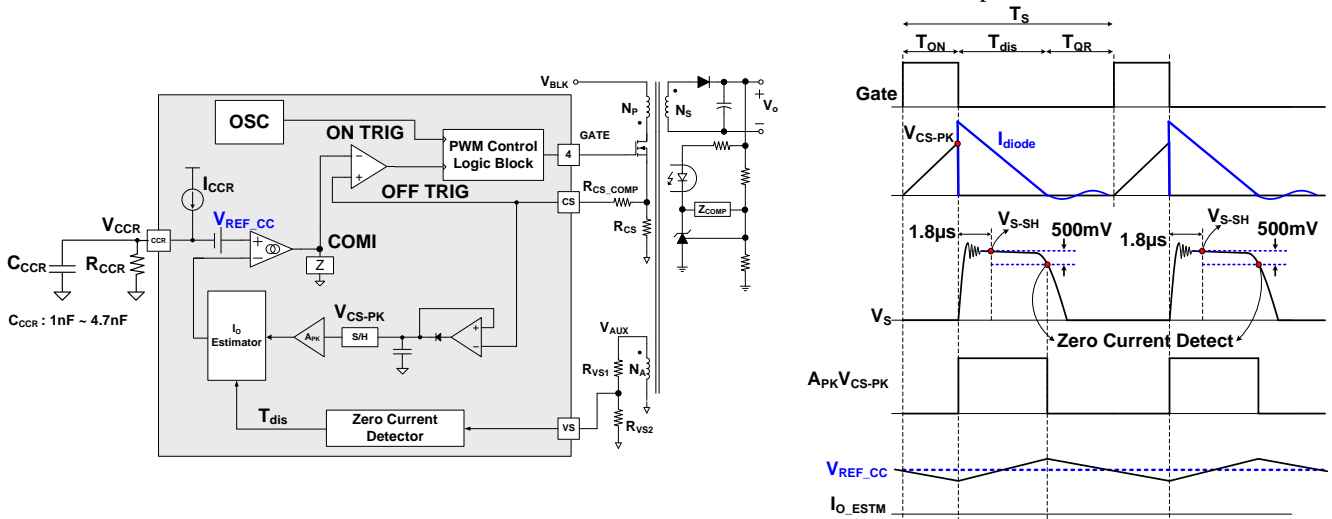

Figure 28 Waveforms for Estimate Output Current

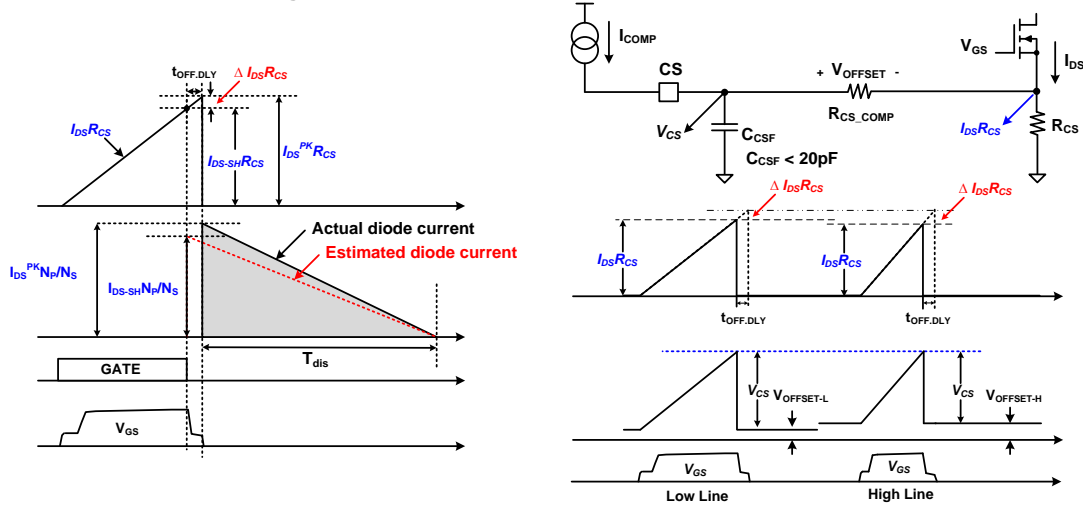

Figure 29 Effect of MOSFET Turn-off Delay and Line Voltage Compensation

CCM Prevention

The constant current calculation logic is based on flyback converter operation in DCM. The output current is estimated by calculating the average of output diode current in one switching cycle. If flyback converter goes into CCM operation, the discharge time of magnetizing current will be fixed. Once this discharge time is fixed, it will increase the average of output diode current. During the CC region, when output voltage becomes lower, the time that the magnetizing current decreases down to zero is longer, as shown in Figure 30. FAN604 provides the lower operation frequency that can be down to 17 kHz ($f_{OSC-MIN}$) to prevent the system goes into CCM operation.

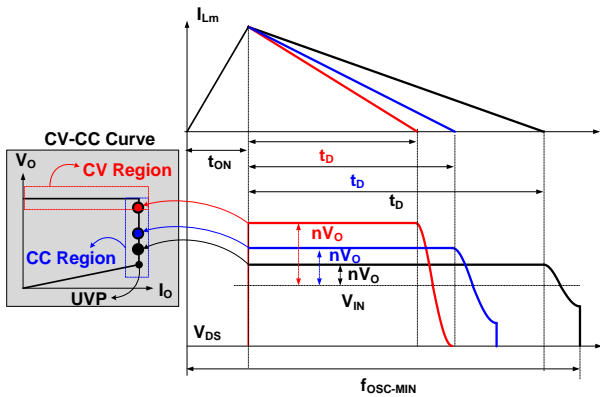

Figure 30 The Minimum Operation Frequency

HV Startup and Brown-In

Figure 31 shows the high-voltage (HV) startup circuit. An Internal JFET provides a high voltage current source, whose characteristics are shown in Figure 32. To improve reliability and surge immunity, it is typical to use a R_{HV} resistor between the HV pin and the bulk capacitor voltage. The actual current flowing into the HV pin at a given bulk capacitor voltage and startup resistor value is determined by the intersection point of characteristics I-V line and the load line as shown in Figure 32.

During startup, the internal startup circuit is enabled and the bulk capacitor voltage supplies the current, I_{HV} , to charge the hold-up capacitor, C_{VDD} , through R_{HV} . When the V_{DD} voltage reaches V_{DD-ON} , the sampling circuit shown in Figure 31 is turned on for t_{HV-det} (100 μ s) to sample the bulk capacitor voltage. Voltage across R_{LS} is compared with reference which generates a signal to start switching. If brown-in condition is not detected within this time, switching does not start. Equation 8 can be used to program the brown-in of the system. If line voltage is lower than the programmed brown-in voltage, FAN604 goes in auto-restart mode.

$$V_{IN} = \frac{R_{LS} + R_{JEFT} + R_{HV}}{R_{LS}} \times V_{REF} \quad (\text{eq. 8})$$

Once switching starts, the internal HV startup circuit is disabled. During normal switching, the line voltage information is obtained from the I_{VS} signal. Once the HV startup circuit is disabled, the energy stored in C_{VDD} supplies the IC operating current until the transformer auxiliary winding voltage reaches the nominal value. Therefore, C_{VDD} should be properly designed to prevent V_{DD} from dropping below V_{DD-OFF} threshold (typically 5.5 V) before the auxiliary winding builds up enough voltage to supply V_{DD} . During startup, the IC current is limited to I_{DD-ST} (300 μ A).

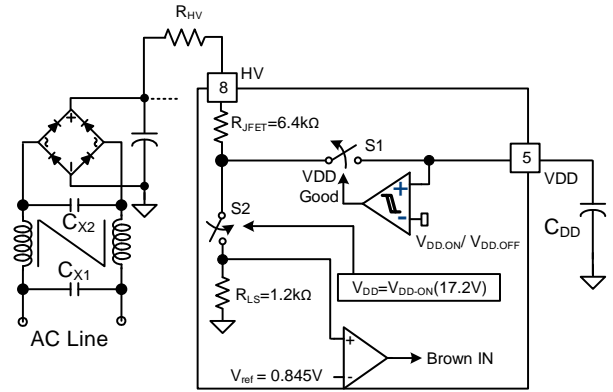

Figure 31 HV Startup Circuit

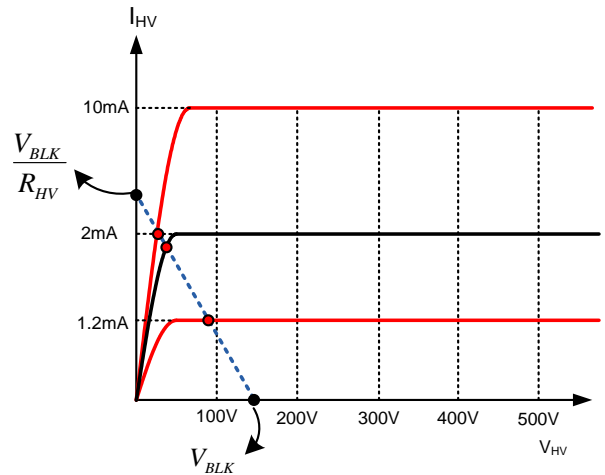

Figure 32 Characteristics of HV pin

Protections

The FAN604 protection functions include VDD Over-Voltage Protection (VDD-OVP), brownout protection, VS Over-Voltage Protection (VS-OVP), VS Under-Voltage Protection (VS-UVP), and IC internal Over-Temperature Protection (OTP). The VDD-OVP, brownout protection, VS-OVP and OTP are implemented with Auto-Restart mode. The VS-UVP is implemented with Extend Auto-Restart mode.

When the Auto-Restart Mode protection is triggered, switching is terminated and the MOSFET remains off, causing VDD to drop because of IC operating current I_{DD-OP} (2 mA). When VDD drops to the VDD turn-off voltage of V_{DD-OFF} (5.5 V), operation current reduces to $I_{DD-Burst}$ (300 μ A). When the VDD voltage drops further to $V_{DD-HV-ON}$, the protection is reset and the supply current drawn from HV pin begins to charge the VDD hold-up capacitor. When VDD reaches the turn-on voltage of V_{DD-ON} (17.2 V), the FAN604 resumes normal operation. In this manner, the Auto-Restart mode alternately enables and disables the switching of the MOSFET until the abnormal condition is eliminated as shown in Figure 33. When the Extend Auto-Restart Mode protection is triggered via VS under-voltage protection (VS-UVP), switching is terminated and the MOSFET remains off, causing VDD to drop. While V_{DD} drops to $V_{DD-HV-ON}$ for HV startup circuit enable, then IC enters Extend Auto-Restart period with two cycles as shown Figure 34. During Extend Auto-Restart period, VDD voltage swings between V_{DD-ON} and $V_{DD-HVON}$ without gate switching, and IC operation current is reduced to $I_{DD-Burst}$ of 300 μ A for slowing down the VDD capacitor discharging slope. As Extend Auto-Restart period ends, normal operation resumes.

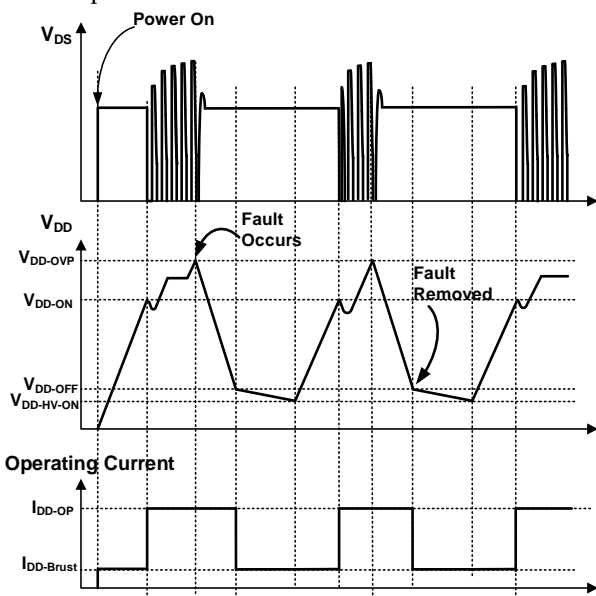

Figure 33 Auto-Restart Mode Operation

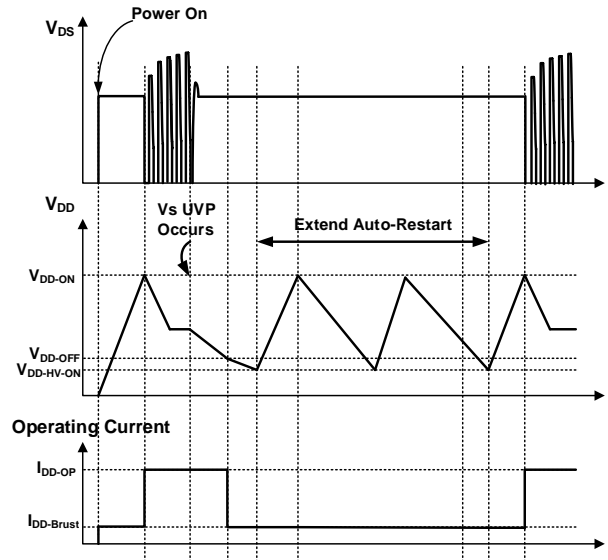

Figure 34 Extend Auto-Restart Mode Operation

VDD Over-Voltage-Protection (VDD-OVP)

VDD over-voltage protection prevents IC damage from over-voltage stress. It is operated in Auto-Restart mode. When the VDD voltage exceeds V_{DD-OVP} (29.0 V) for the de-bounce time, $t_{D-VDDOVP}$ (70 μ s), due to abnormal condition, the protection is triggered. This protection is typically caused by an open circuit of secondary side feedback network.

Brownout Protection

Line voltage information is used for brownout protection. When the I_{VS} current out of the VS pin during the MOSFET conduction time is less than 450 μ A for longer than 16.5 ms, the brownout protection is triggered. The input bulk capacitor voltage to trigger brownout protection is given as

$$V_{BLK.BO} = 1.2 \times 450 \mu A \times \frac{R_{VS1}}{N_A / N_P} \quad (\text{eq. 9})$$

IC Internal Over-Temperature-Protection (OTP)

The internal temperature-sensing circuit disables the PWM output if the junction temperature exceeds 140°C (T_{OTP}) and the FAN604 enters Auto-Restart Mode protection.

VS Over-Voltage-Protection (VS-OVP)

VS over-voltage protection prevents damage caused by output over-voltage condition. It is operated in Auto-Restart mode. Figure 35 shows the internal circuit of VS-OVP protection. When abnormal system conditions occur, which cause VS sampling voltage to exceed V_{VS-OVP} (2.3V) for more than 2 consecutive switching cycles (N_{VS-OVP}), PWM pulses are disabled and FAN604 enters Auto-Restart protection. VS over-voltage conditions are usually caused by open circuit of the secondary side feedback network or a fault condition in the VS pin voltage divider resistors. For VS pin voltage divider design, R_{VS1} is obtained from Equation 9, and R_{VS2} is determined by the desired VS-OVP protection function as

$$R_{VS2} = R_{VS1} \frac{1}{\frac{V_{O-OVP}}{V_{VS-OVP}} \frac{N_A}{N_S} - 1} \quad (\text{eq. 10})$$

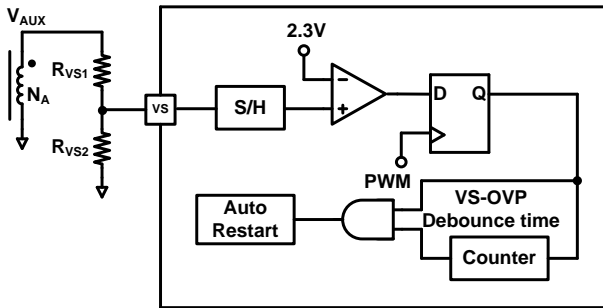

Figure 35 VS-OVP Protection Circuit

VS Under-Voltage-Protection (VS-UVP)

In the event of an output short, output voltage will drop and the primary peak current will increase. To prevent operation for a long time in this condition, FAN604 incorporates under-voltage protection through VS pin. Figure 36 shows the internal circuit for VS-UVP. By sampling the auxiliary winding voltage on the VS pin at the end of diode conduction time, the output voltage is indirectly sensed. When V_S sampling voltage is less than V_{VS-UVP} (0.65 V) and longer than de-bounce cycles N_{VS-UVP} , VS-UVP is triggered and the FAN604 enters Extend Auto-Restart Mode.

To avoid VS-UVP triggering during the startup sequence, a startup blanking time, $t_{VS-UVP-BLANK}$ (40 ms), is included for system power on. For VS pin voltage divider design, R_{VS1} is obtained from Equation 9 and R_{VS2} is determined by Equation 10. V_{O-UVP} can be determined by Equation 11.

$$V_{O-UVP} = \frac{N_S}{N_A} \left(1 + \frac{R_{VS1}}{R_{VS2}}\right) \cdot V_{VS-UVP} \quad (\text{eq. 11})$$

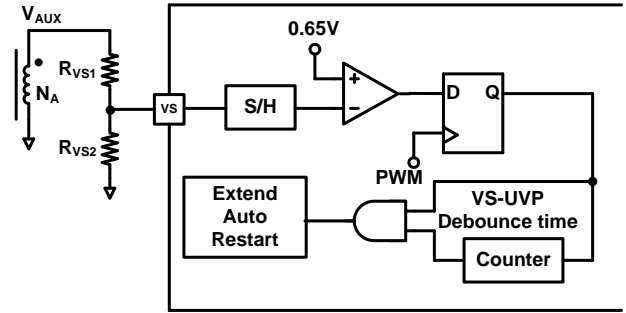

Figure 36 VS-UVP Protection Circuit

Externally Triggered Shutdown (SD)

When V_{DD} is V_{DD-ON} , Shut-Down comparing level is $V_{SD-TH-ST}$ (1.35V), after the startup time t_{SD-ST} (1ms), the comparing level is changed to V_{SD-TH} (1.0 V). By pulling down SD pin voltage below the V_{SD-TH} (1.0 V) shutdown can be externally triggered and the FAN604 will enter Auto-Restart mode protection. It can be also used for external Over-Temperature-Protection by connecting a NTC thermistor between the shutdown (SD) programming pin and ground. An internal constant current source I_{SD} (103 μ A) creates a voltage drop across the thermistor. The resistance of the NTC thermistor becomes smaller as the ambient temperature increases, which reduces the voltage drop across the thermistor. SD pin voltage is sampled every gate cycle when $V_{FB} > V_{FB-BURST-H}$ and sampled continuously when $V_{FB} < V_{FB-BURST-L}$. When the voltage at SD pin is sampled to be below the threshold voltage, V_{SD-TH} (1.0 V), for a de-bounce time of t_{D-SD} (400 μ s), Auto-Restart protection is triggered. A capacitor may also be placed in parallel with the NTC thermistor to further improve the noise immunity. The capacitor should be designed such that SD pin voltage is more than $V_{SD-TH-ST}$ within the time of t_{SD-ST} .

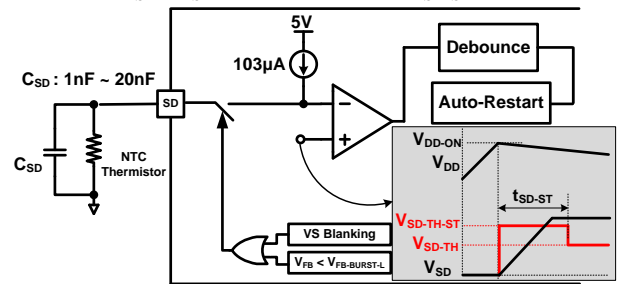

Figure 37 External OTP using SD Pin

FAN604

Pulse-by-Pulse Current Limit

During startup or overload condition, the feedback loop is saturated to high and is unable to control the primary peak current. To limit the current during such conditions, FAN604 has pulse-by-pulse current limit protection which forces the GATE to turn off when the CS pin voltage reaches the current limit threshold, V_{CS-LIM} (0.89 V).

Secondary-Side Diode Shot Protection

When the secondary-side diode is damaged, the slope of the primary-side peak current will be sharp within leading-edge blanking time. To limit the current during such conditions, FAN604 has secondary-side diode short protection which forces the GATE to turn off when the CS pin voltage reaches 1.6 V. After one switching cycle, it will operate in Auto-Restart mode as shown in Figure 38.

Current Sense Short Protection

Current sense short protection prevents damage caused by CS pin open or short to ground. After two switching cycles, it will operate in Auto-Restart mode. Figure 38 shows the internal circuit of current sense short protection. When abnormal system conditions occur, which cause CS pin voltage lower than 0.2 V after de-bounce time ($t_{CS-short}$) for more than 2 consecutive switching cycles, PWM pulses are disabled and FAN604 enters Auto-Restart protection. The $I_{CS-Short}$ is an internal current source, which is proportional to line voltage. The de-bounce time ($t_{CS-short}$) is created by $I_{CS-Short}$, capacitor (2 pF) and threshold voltage (3.0 V). This de-bounce time ($t_{CS-short}$) is inversely proportional to the DC link capacitor voltage, V_{BLK} .

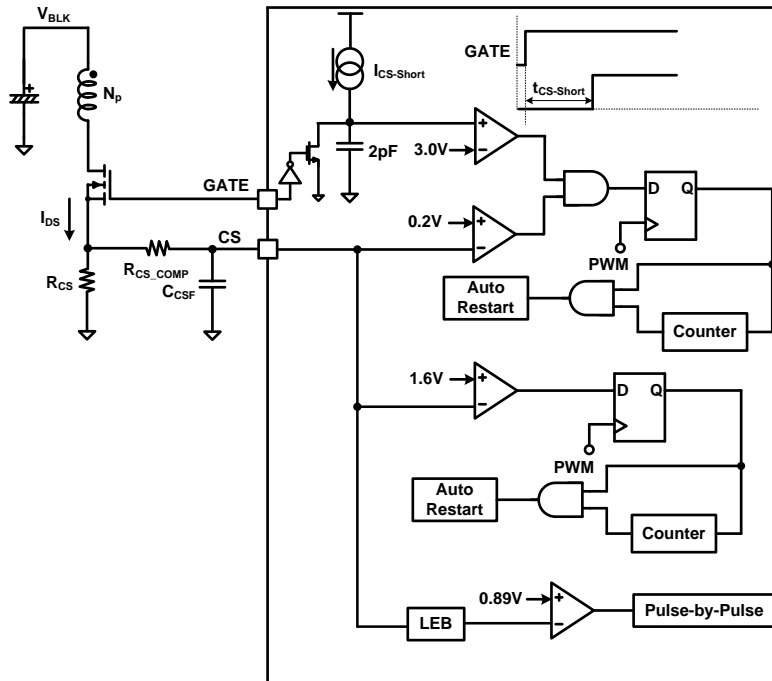

Figure 38 Current Sense Protection Circuit

FAN604

PCB Layout Guideline

Print circuit board (PCB) layout and design are very important for switching power supplies where the voltage and current change with high dv/dt and di/dt . Good PCB layout minimizes excessive EMI and prevents the power supply from being disrupted during surge/ESD tests. The following guidelines are recommended for layout designs.

- To improve EMI performance and reduce line frequency ripples, the output of the bridge rectifier should be connected to capacitors C_{BLK1} and C_{BLK2} first, then to the transformer and MOSFET.
- The primary-side high-voltage current loop is **C_{BLK2} - Transformer - MOSFET - R_{CS} - C_{BLK2}** . The area enclosed by this current loop should be as small as possible. The trace for the control signal (FB, CS, VS and GATE) should not go across this primary high-voltage current loop to avoid interference.
- Place R_{HV} for protection against the inrush spike on the HV pin (150k Ω is recommended).
- R_{CS} should be connected to the ground of C_{BLK2} directly. Keep the trace short and wide (Trace 4 to 1) and place it close to the CS pin to reduce switching noise. High-voltage traces related to the drain of MOSFET and RCD snubber should be away from control circuits to prevent unnecessary interference. If a heat sink is used for the MOSFET, connect this heat sink to ground.

- As indicated by 2, the area enclosed by the transformer auxiliary winding, D_{AUX} and C_{VDD} , should also be small.
- Place C_{VDD} , C_{VS} , R_{VS2} , C_{FB} , R_{CCR} , C_{CCR} , R_{CS_COMP} and C_{CSF} close to the controller for good decoupling and low switching noise.
- As indicated by 3, the ground of the control circuits should be connected as a single point first, then to other circuitry.
- Connect ground by 3 to 2 to 4 to 1 sequence. This helps to avoid common impedance interference for the sense signal.
- Regarding the ESD discharge path, use the shortcut pad between AC line and DC output (most recommended). Another method is to discharge the ESD energy to the AC line through the primary-side main ground 1. Because ESD energy is delivered from the secondary side to the primary side through the transformer stray capacitor or the Y capacitor, the controller circuit should not be placed on the discharge path. 5 shows where the point-discharge route can be placed to effectively bypass the static electricity energy.
- For the surge path, select fusible resistor of wire wound type to reduce inrush current and surge energy and use π input filter (two bulk capacitors and one inductance) to share the surge energy.

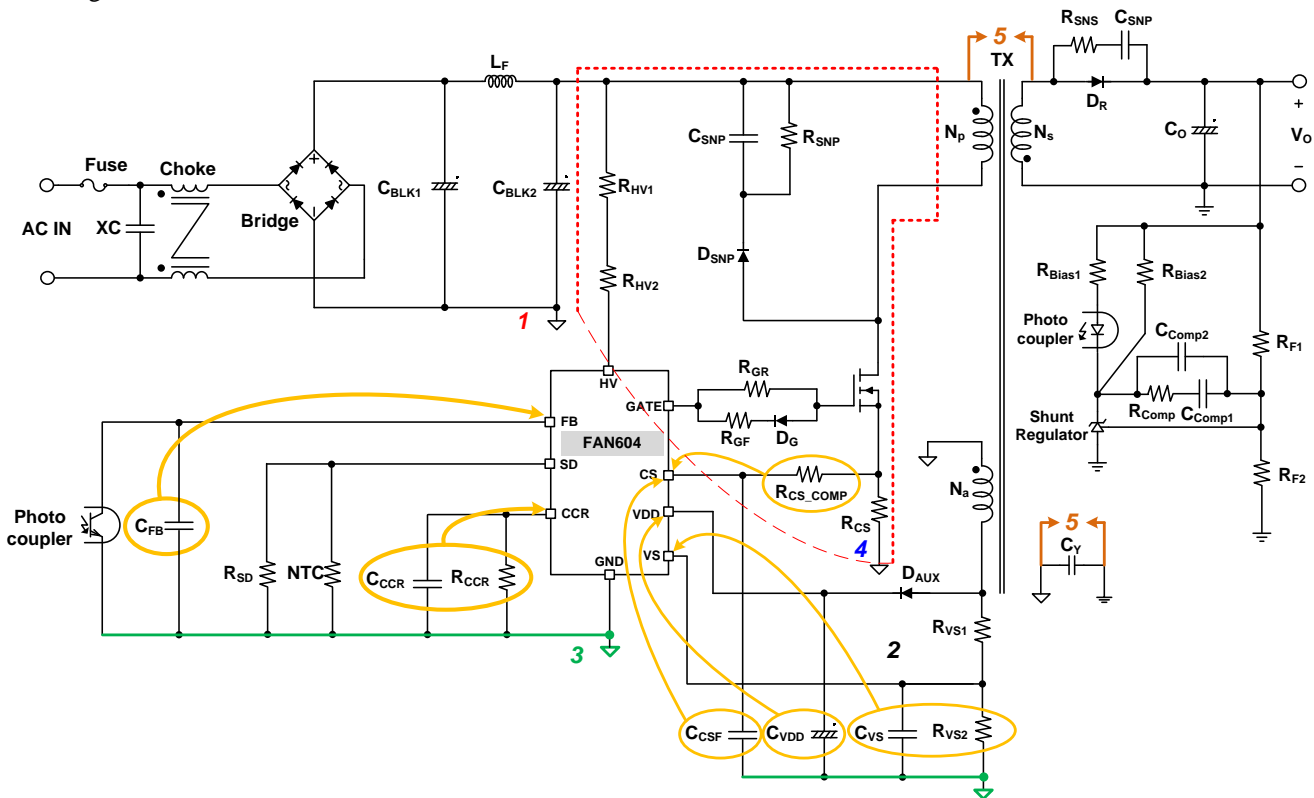

Figure 39 Recommended Layout for FAN604

FAN604

ORDERING INFORMATION

Device	Operating Temperature Range	Package	Shipping †
FAN604MX	-40°C to +125°C	10-Lead, Small Outline Package (SOIC), JEDEC MS-012, .150-Inch Narrow Body	Tape & Reel

†For information on tape and reel specifications, including part orientation and tape sizes, please refer to our Tape and Reel Packaging Specifications Brochure, BRD8011/D

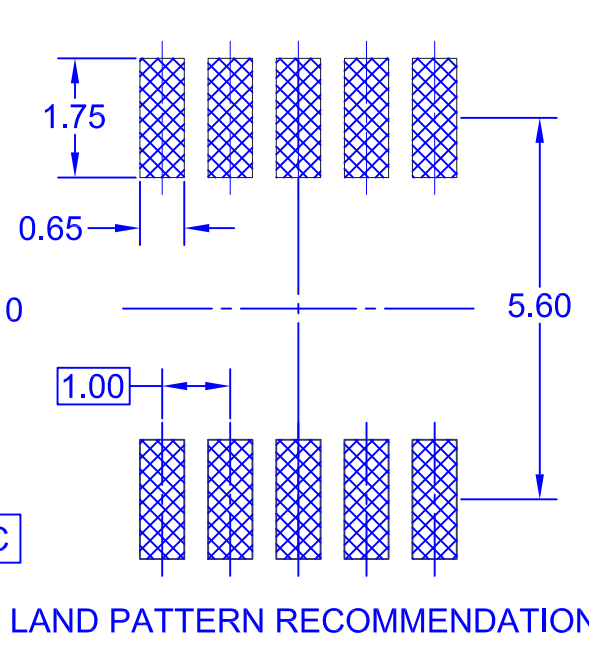
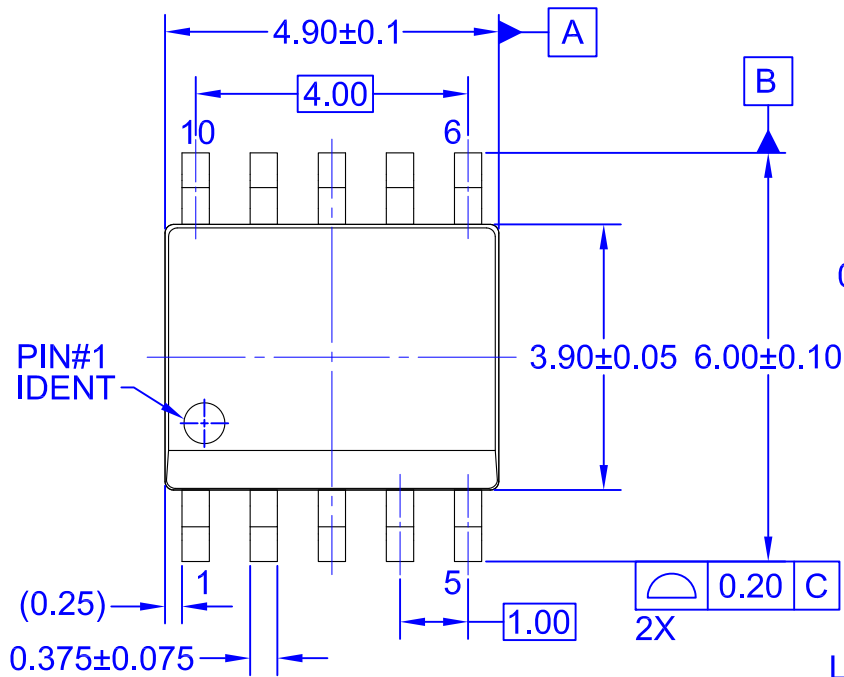

TOP VIEW

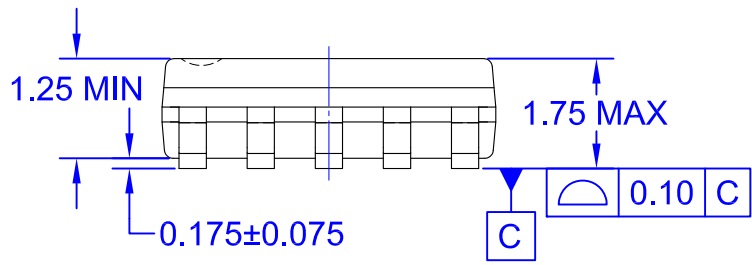

SIDE VIEW

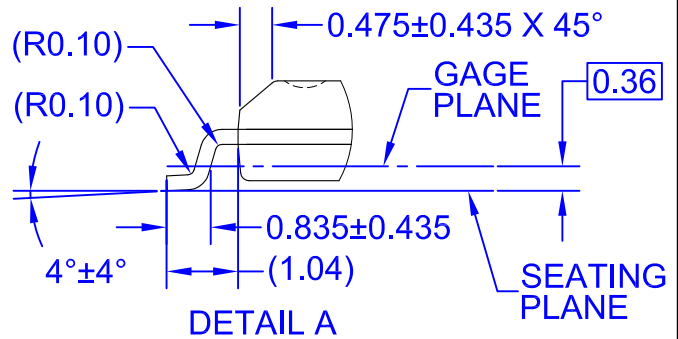

DETAIL A

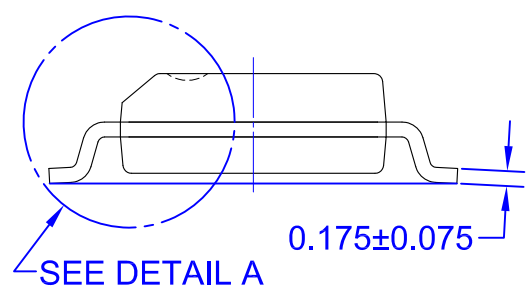

FRONT VIEW

- NOTES:
- A. THIS PACKAGE DOES NOT FULLY CONFORM TO JEDEC REGISTRATION, MS-012.
 - B. ALL DIMENSIONS ARE IN MILLIMETERS.
 - C. DIMENSIONS DO NOT INCLUDE MOLD FLASH OR BURRS.
 - D. LAND PATTERN STANDARD: SOIC127P600X175.10M
 - E. DRAWING FILENAME: MKT-M10ArevB

ON Semiconductor



ON Semiconductor and  are trademarks of Semiconductor Components Industries, LLC dba ON Semiconductor or its subsidiaries in the United States and/or other countries. ON Semiconductor owns the rights to a number of patents, trademarks, copyrights, trade secrets, and other intellectual property. A listing of ON Semiconductor's product/patent coverage may be accessed at www.onsemi.com/site/pdf/Patent-Marking.pdf. ON Semiconductor reserves the right to make changes without further notice to any products herein. ON Semiconductor makes no warranty, representation or guarantee regarding the suitability of its products for any particular purpose, nor does ON Semiconductor assume any liability arising out of the application or use of any product or circuit, and specifically disclaims any and all liability, including without limitation special, consequential or incidental damages. Buyer is responsible for its products and applications using ON Semiconductor products, including compliance with all laws, regulations and safety requirements or standards, regardless of any support or applications information provided by ON Semiconductor. "Typical" parameters which may be provided in ON Semiconductor data sheets and/or specifications can and do vary in different applications and actual performance may vary over time. All operating parameters, including "Typicals" must be validated for each customer application by customer's technical experts. ON Semiconductor does not convey any license under its patent rights nor the rights of others. ON Semiconductor products are not designed, intended, or authorized for use as a critical component in life support systems or any FDA Class 3 medical devices or medical devices with a same or similar classification in a foreign jurisdiction or any devices intended for implantation in the human body. Should Buyer purchase or use ON Semiconductor products for any such unintended or unauthorized application, Buyer shall indemnify and hold ON Semiconductor and its officers, employees, subsidiaries, affiliates, and distributors harmless against all claims, costs, damages, and expenses, and reasonable attorney fees arising out of, directly or indirectly, any claim of personal injury or death associated with such unintended or unauthorized use, even if such claim alleges that ON Semiconductor was negligent regarding the design or manufacture of the part. ON Semiconductor is an Equal Opportunity/Affirmative Action Employer. This literature is subject to all applicable copyright laws and is not for resale in any manner.

PUBLICATION ORDERING INFORMATION

LITERATURE FULFILLMENT:

Literature Distribution Center for ON Semiconductor
19521 E. 32nd Pkwy, Aurora, Colorado 80011 USA
Phone: 303-675-2175 or 800-344-3860 Toll Free USA/Canada
Fax: 303-675-2176 or 800-344-3867 Toll Free USA/Canada
Email: orderlit@onsemi.com

N. American Technical Support: 800-282-9855 Toll Free
USA/Canada
Europe, Middle East and Africa Technical Support:
Phone: 421 33 790 2910
Japan Customer Focus Center
Phone: 81-3-5817-1050

ON Semiconductor Website: www.onsemi.com
Order Literature: <http://www.onsemi.com/orderlit>
For additional information, please contact your local
Sales Representative

Mouser Electronics

Authorized Distributor

Click to View Pricing, Inventory, Delivery & Lifecycle Information:

[ON Semiconductor:](#)

[FAN604MX](#) [FAN604GMX](#)

Компания «Океан Электроники» предлагает заключение долгосрочных отношений при поставках импортных электронных компонентов на взаимовыгодных условиях!

Наши преимущества:

- Поставка оригинальных импортных электронных компонентов напрямую с производств Америки, Европы и Азии, а так же с крупнейших складов мира;
- Широкая линейка поставок активных и пассивных импортных электронных компонентов (более 30 млн. наименований);
- Поставка сложных, дефицитных, либо снятых с производства позиций;
- Оперативные сроки поставки под заказ (от 5 рабочих дней);
- Экспресс доставка в любую точку России;
- Помощь Конструкторского Отдела и консультации квалифицированных инженеров;
- Техническая поддержка проекта, помощь в подборе аналогов, поставка прототипов;
- Поставка электронных компонентов под контролем ВП;
- Система менеджмента качества сертифицирована по Международному стандарту ISO 9001;
- При необходимости вся продукция военного и аэрокосмического назначения проходит испытания и сертификацию в лаборатории (по согласованию с заказчиком);
- Поставка специализированных компонентов военного и аэрокосмического уровня качества (Xilinx, Altera, Analog Devices, Intersil, Interpoint, Microsemi, Actel, Aeroflex, Peregrine, VPT, Syfer, Eurofarad, Texas Instruments, MS Kennedy, Miteq, Cobham, E2V, MA-COM, Hittite, Mini-Circuits, General Dynamics и др.);

Компания «Океан Электроники» является официальным дистрибьютором и эксклюзивным представителем в России одного из крупнейших производителей разъемов военного и аэрокосмического назначения «JONHON», а так же официальным дистрибьютором и эксклюзивным представителем в России производителя высокотехнологичных и надежных решений для передачи СВЧ сигналов «FORSTAR».



JONHON

«JONHON» (основан в 1970 г.)

Разъемы специального, военного и аэрокосмического назначения:

(Применяются в военной, авиационной, аэрокосмической, морской, железнодорожной, горно- и нефтедобывающей отраслях промышленности)

«FORSTAR» (основан в 1998 г.)

ВЧ соединители, коаксиальные кабели, кабельные сборки и микроволновые компоненты:

(Применяются в телекоммуникациях гражданского и специального назначения, в средствах связи, РЛС, а так же военной, авиационной и аэрокосмической отраслях промышленности).



Телефон: 8 (812) 309-75-97 (многоканальный)

Факс: 8 (812) 320-03-32

Электронная почта: ocean@oceanchips.ru

Web: <http://oceanchips.ru/>

Адрес: 198099, г. Санкт-Петербург, ул. Калинина, д. 2, корп. 4, лит. А