

---

## 5.1-5.9 GHz 802.11ac WLAN Power Amplifier

---

### Features

- 50Ω input and output match including DC blocks
- Integrated harmonic filter
- Operating voltage:  $V_{CC} = 5.0V$
- Operating frequency: 5.1 to 5.9 GHz
- High linear output power, typical performance:
  - 802.11a OFDM Spectrum mask compliant up to 24 dBm
  - 802.11n HT40 OFDM Spectrum mask compliant up to 23 dBm
  - 3% EVM up to 20 dBm for 802.11a, 54 Mbps signal
  - 2.5% EVM up to 19 dBm for 802.11n, HT40
  - 1.8% EVM up to 18 dBm for 802.11ac, MCS9, 80 MHz BW (bandwidth) signal
- Gain: Typically 31 dB gain across 5.1–5.9 GHz
- Idle current: Typically ~320 mA  $I_{CQ}$
- High-speed power-up/down
  - Turn on/off time (10%-90%) <100 ns
- Shut-down current (~2  $\mu A$ )
- On-chip power detection
  - >20 dB linear dynamic range
  - VSWR insensitive
- All devices are RoHS compliant

### Applications

- WLAN (IEEE 802.11a/n/ac)
- HyperLAN2
- Multimedia

### Product Description

SST11CP22 is a 50Ω, RF-matched Power Amplifier Module (PAM) with a FCC-compliant, harmonic filter that is based on the highly-reliable InGaP/GaAs HBT technology.

Operating over the 5.1–5.9 GHz frequency band, SST11CP22 meets 802.11a spectrum mask requirements up to 24 dBm and 802.11n HT40 spectrum mask at 23 dBm. With 802.11a modulation, this PA typically provides up to 20.5 dBm with 3% EVM, and provides 18 dBm with less than 1.8% dynamic EVM using 802.11ac modulation, MCS9, 80 MHz bandwidth.

This power amplifier module also features easy board-level operation, with a simple application circuit requiring only four external components. With its high-speed power-up/-down control, SST11CP22 is controllable directly from the base-band chip.

SST11CP22 also features a wide dynamic-range, linear power detector that is temperature-stable and VSWR-insensitive.

SST11CP22 is offered in 20-contact QFN package. See [Figure 2-1](#) for pin assignments and [Table 2-1](#) for pin descriptions.

## TO OUR VALUED CUSTOMERS

It is our intention to provide our valued customers with the best documentation possible to ensure successful use of your Microchip products. To this end, we will continue to improve our publications to better suit your needs. Our publications will be refined and enhanced as new volumes and updates are introduced.

If you have any questions or comments regarding this publication, please contact the Marketing Communications Department via E-mail at [docerrors@microchip.com](mailto:docerrors@microchip.com). We welcome your feedback.

### Most Current Data Sheet

To obtain the most up-to-date version of this data sheet, please register at our Worldwide Web site at:

<http://www.microchip.com>

You can determine the version of a data sheet by examining its literature number found on the bottom outside corner of any page. The last character of the literature number is the version number, (e.g., DS30000000A is version A of document DS30000000).

### Errata

An errata sheet, describing minor operational differences from the data sheet and recommended workarounds, may exist for current devices. As device/documentation issues become known to us, we will publish an errata sheet. The errata will specify the revision of silicon and revision of document to which it applies.

To determine if an errata sheet exists for a particular device, please check with one of the following:

- Microchip's Worldwide Web site; <http://www.microchip.com>
- Your local Microchip sales office (see last page)

When contacting a sales office, please specify which device, revision of silicon and data sheet (include literature number) you are using.

### Customer Notification System

Register on our web site at [www.microchip.com](http://www.microchip.com) to receive the most current information on all of our products.

1.0 FUNCTIONAL BLOCKS

FIGURE 1-1: FUNCTIONAL BLOCK DIAGRAM

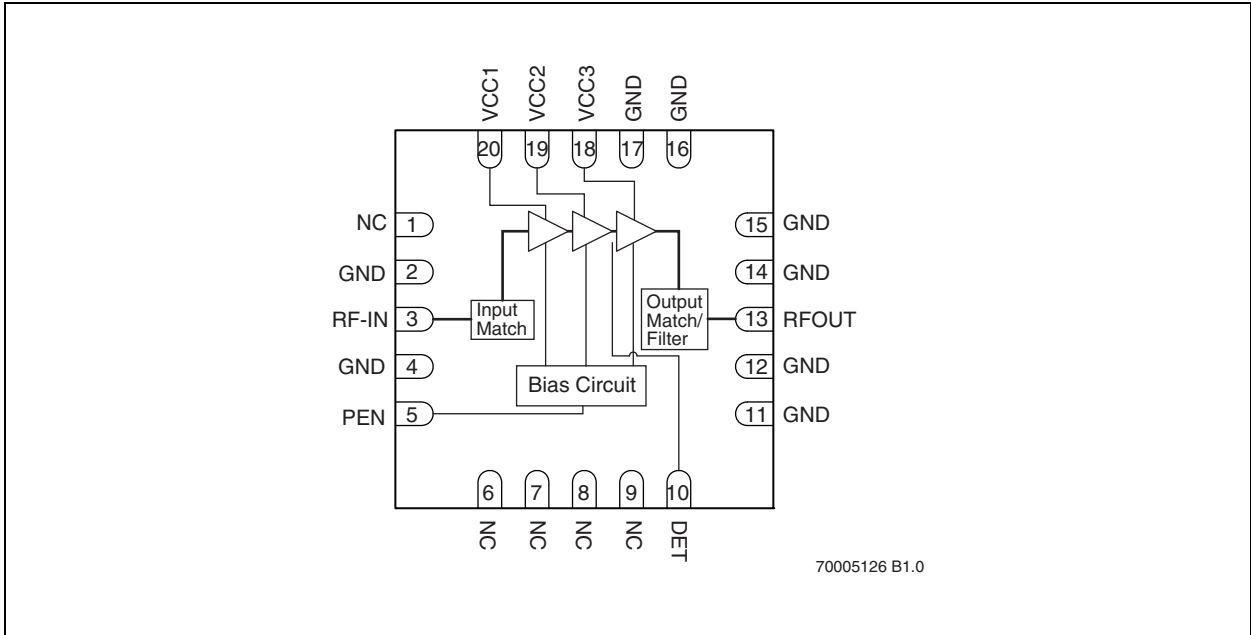

## 2.0 PIN ASSIGNMENTS

**FIGURE 2-1: PIN ASSIGNMENTS FOR 20-CONTACT UQFN**

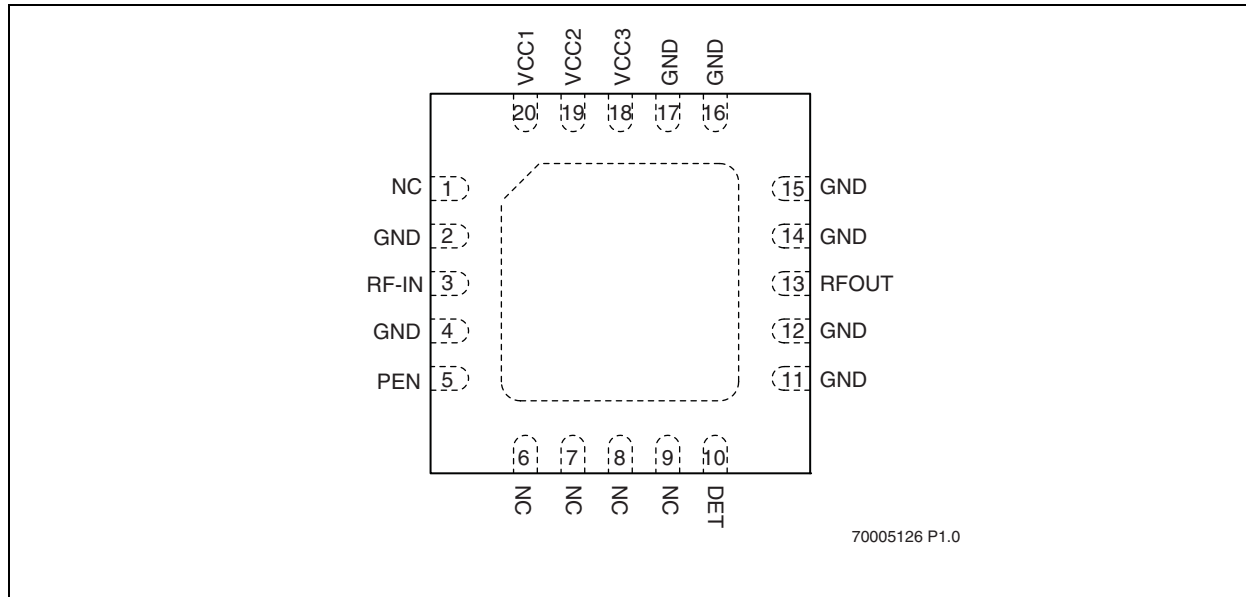

**TABLE 2-1: PIN DESCRIPTION**

Symbol	Pin No.	Pin Name	Function
GND	0	Center ground contact	The center pad should be connected to RF ground with several low inductance, low resistance vias.
NC	1	No Connection	Unconnected, no internal connection
GND	2	Ground	
RFIN	3	RF input	RF input port
GND	4	Ground	
PEN	5	PA enable	PA enable control input
NC	6	No Connection	Unconnected, no internal connection
NC	7	No Connection	Unconnected, no internal connection
NC	8	No Connection	Unconnected, no internal connection
NC	9	No Connection	Unconnected, no internal connection
DET	10	TX detector output	TX detector output
GND	11	Ground	
GND	12	Ground	
RF OUT	13	RF Out	RF Output port
GND	14	Ground	
GND	15	Ground	
GND	16	Ground	
GND	17	Ground	
VCC3	18	PA supply	PA Supply
VCC2	19	PA supply	PA Supply
VCC1	20	PA supply	PA Supply

### 3.0 ELECTRICAL SPECIFICATIONS

The AC and DC specifications for the power amplifier interface signals. Refer to [Table 3-2](#) for the DC voltage and current specifications. Refer to [Figures 4-1 through 4-7](#) for the RF performance.

**Absolute Maximum Stress Ratings** (Applied conditions greater than those listed under “Absolute Maximum Stress Ratings” may cause permanent damage to the device. This is a stress rating only and functional operation of the device at these conditions or conditions greater than those defined in the operational sections of this data sheet is not implied. Exposure to absolute maximum stress rating conditions may affect device reliability.)

Supply Voltage at pins 18, 19, and 20 ( $V_{CC}$ )	-0.3V to +6.5V
Supply voltage to pins 5, 6, and 7 ( $V_{PEN}$ )	-0.3V to +3.6V
DC supply current ( $I_{CC}$ )	600 mA
Operating Temperature ( $T_A$ )	-20°C to +85°C
Storage Temperature ( $T_{STG}$ )	-40°C to +120°C
Maximum Junction Temperature ( $T_J$ )	+150°C
Maximum Output Power	26 dBm
Surface Mount Solder Reflow Temperature	260°C for 10 seconds

**TABLE 3-1: OPERATING RANGE**

Range	Ambient Temp	$V_{CC}$
Industrial	-10°C to +85°C	5.0V-6.0V

**TABLE 3-2: DC ELECTRICAL CHARACTERISTICS**

Symbol	Parameter	Min.	Typ	Max.	Unit
$V_{CC}$	Supply Voltage		5.0	6.0	V
$I_{CC}$	Supply Current @ $P_{OUT} = 20$ dBm		370		mA
$I_{CQ}$	$V_{CC}$ Quiescent Current		320		mA
$I_{OFF}$	Shutdown Current		2		$\mu$ A
$V_{PEN}$	Recommended Enable Voltage		2.85		V
$I_{PEN}$	Total Enable Current		8		mA
$V_{DET}$	RF Power Detector Voltage Output Range, 0 to 23 dBm	0.15		1.0	V
	Voltage at 20 dBm		0.75		V

**TABLE 3-3: AC ELECTRICAL CHARACTERISTICS FOR CONFIGURATION  $V_{CC} = 5.0V$ ,  $V_{PEN}=2.85V$ , 25 °C UNLESS OTHERWISE SPECIFIED**

Symbol	Parameter	Min.	Typ	Max.	Unit
$F_{L-U}$	Frequency range	5.1		5.9	GHz
Linear Power	Output power at 3% EVM at 54 Mbps OFDM signal, 802.11a		20.5		dBm
	Output power at 2.5% dynamic EVM 802.11n HT40		19		dBm
	Output power 1.8% dynamic EVM MCS9 80 MHz BW		18		dBm
	ACPR <sub>A</sub> output power level with 802.11a mask compliance @ 6Mbps OFDM		24		dBm
	ACPR <sub>N40</sub> output power level with 802.11n HT40 mask compliance		23		dBm
G	Power gain from 5.18-5.9 GHz		31		dB
RL	RF input return loss		10		dB
$2f_0$	Second harmonic power density at 24 dBm		-45		dBm/MHz
$3f_0$	Third harmonic power density at 24 dBm		-50		dBm/MHz

### 4.0 TYPICAL PERFORMANCE CHARACTERISTICS

Test Conditions:  $V_{CC} = 5.0V$ ,  $T_A = 25^\circ C$ ,  $V_{PEN} = 2.85V$ , 802.11a 54 Mbps OFDM Modulation, 50% Duty Cycle,  $25^\circ C$  Unless otherwise specified

FIGURE 4-1: S-PARAMETERS

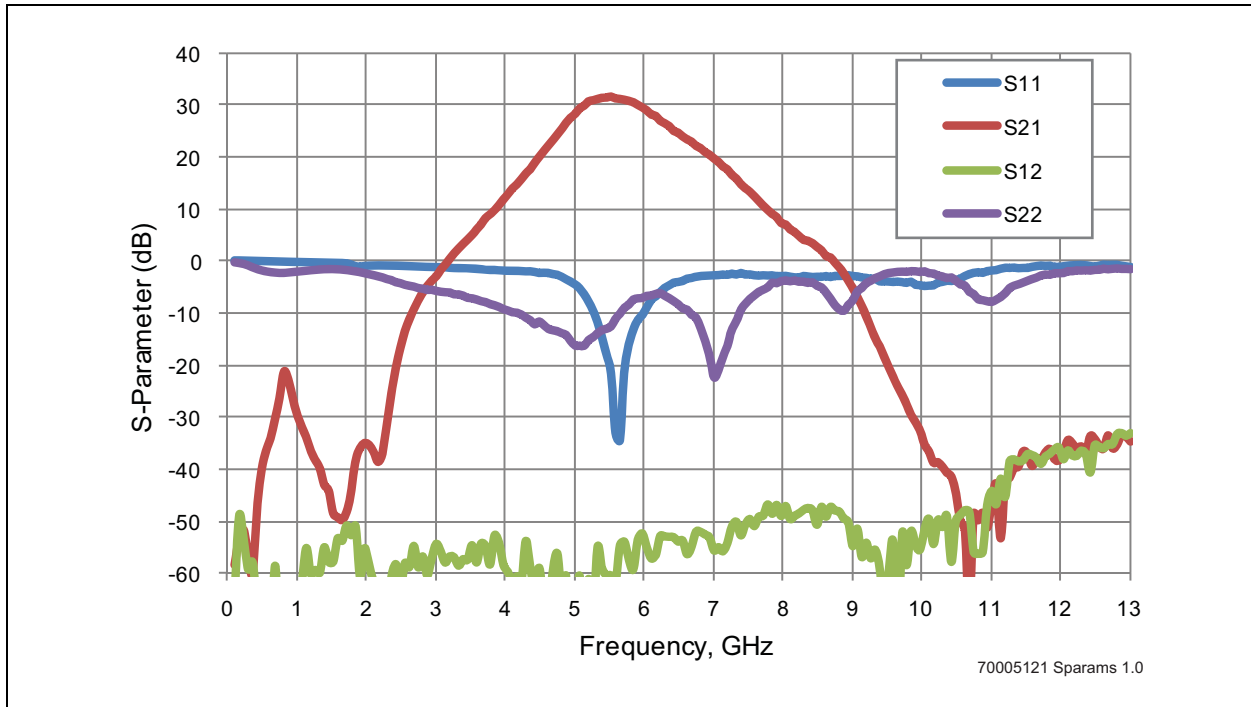

FIGURE 4-2: DYNAMIC EVM VERSUS OUTPUT POWER, 802.11a 54 Mbps, 50% DUTY CYCLE,  $V_{PEN}=2.85V$

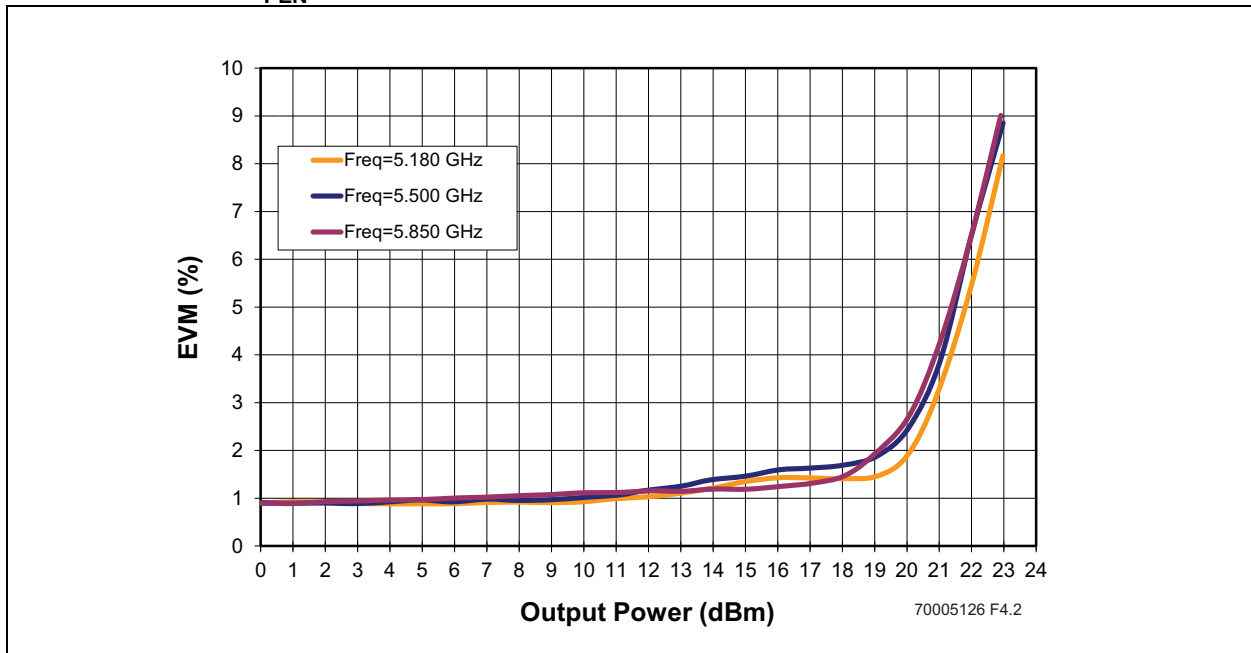

FIGURE 4-3: DYNAMIC EVM VERSUS OUTPUT POWER, 802.11n MCS7-HT40, 40 MHz, 50% DUTY CYCLE,  $V_{PEN}=2.85V$

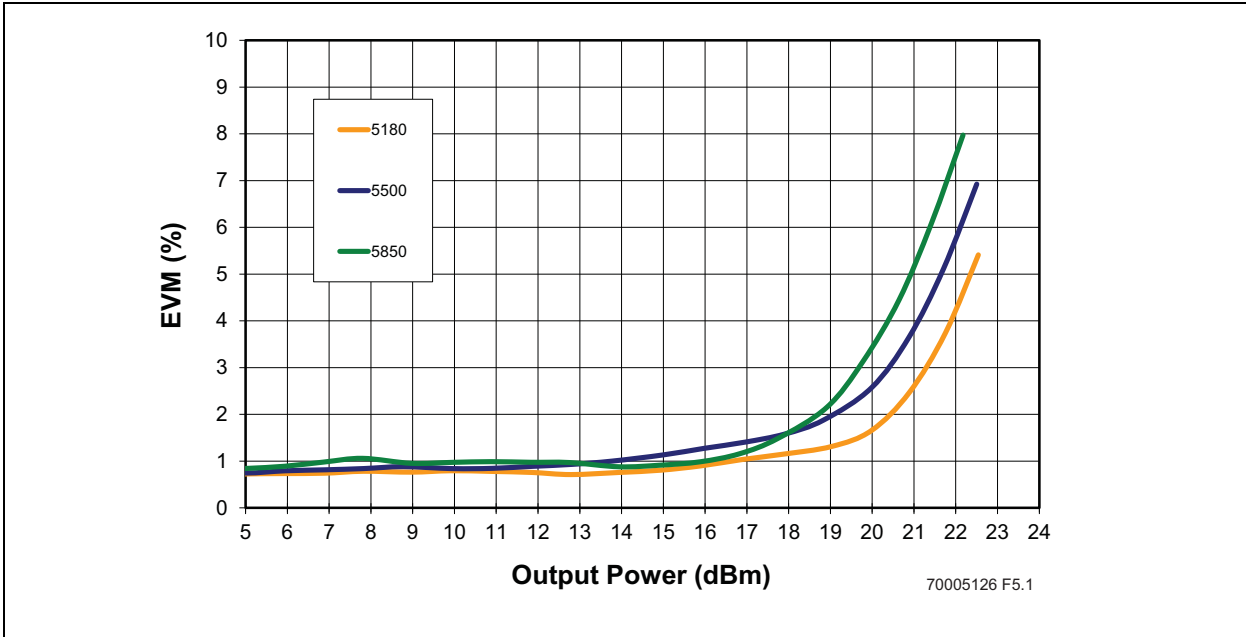
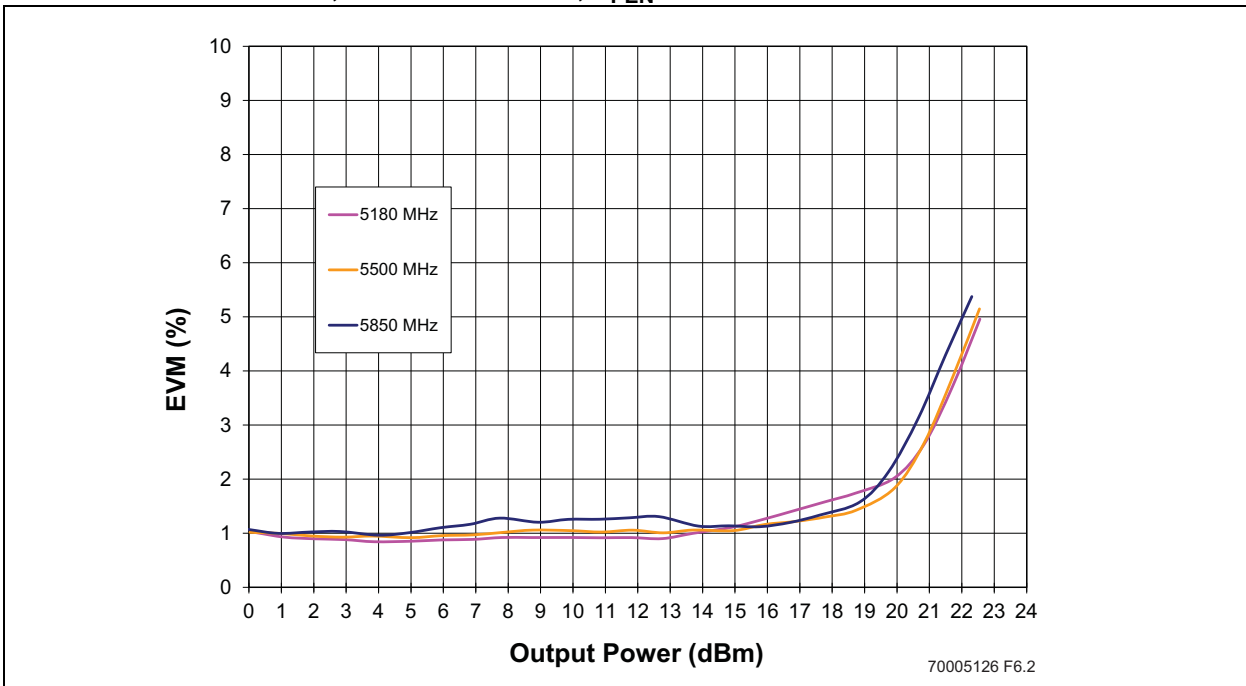
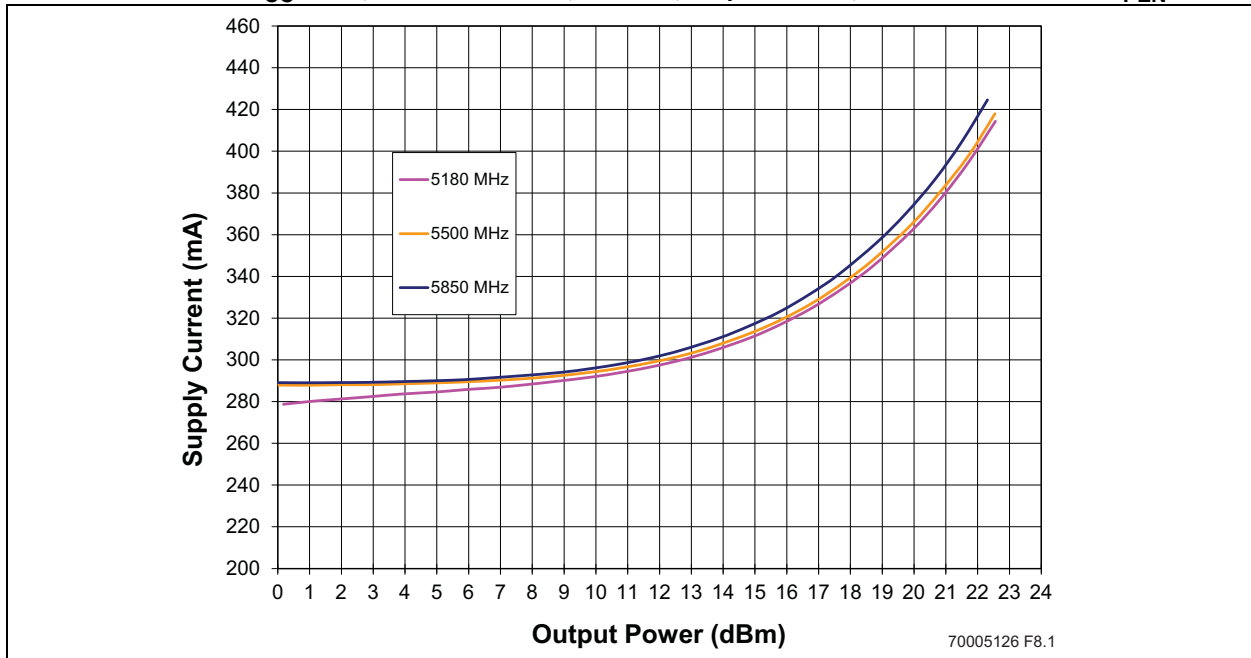

FIGURE 4-4: DYNAMIC EVM VERSUS OUTPUT POWER, 802.11ac MCS9, 80 MHz, 60  $\mu S$  PULSE, 50% DUTY CYCLE,  $V_{PEN}=2.85V$





**FIGURE 4-5: INSTANTANEOUS POWER SUPPLY CURRENT VERSUS OUTPUT POWER,  $V_{CC}=5.0V$ , 802.11ac MCS9, 80 MHz, 60  $\mu s$  PULSE, 50% DUTY CYCLE  $V_{PEN}=2.85V$**



**FIGURE 4-6: POWER GAIN VERSUS OUTPUT POWER**

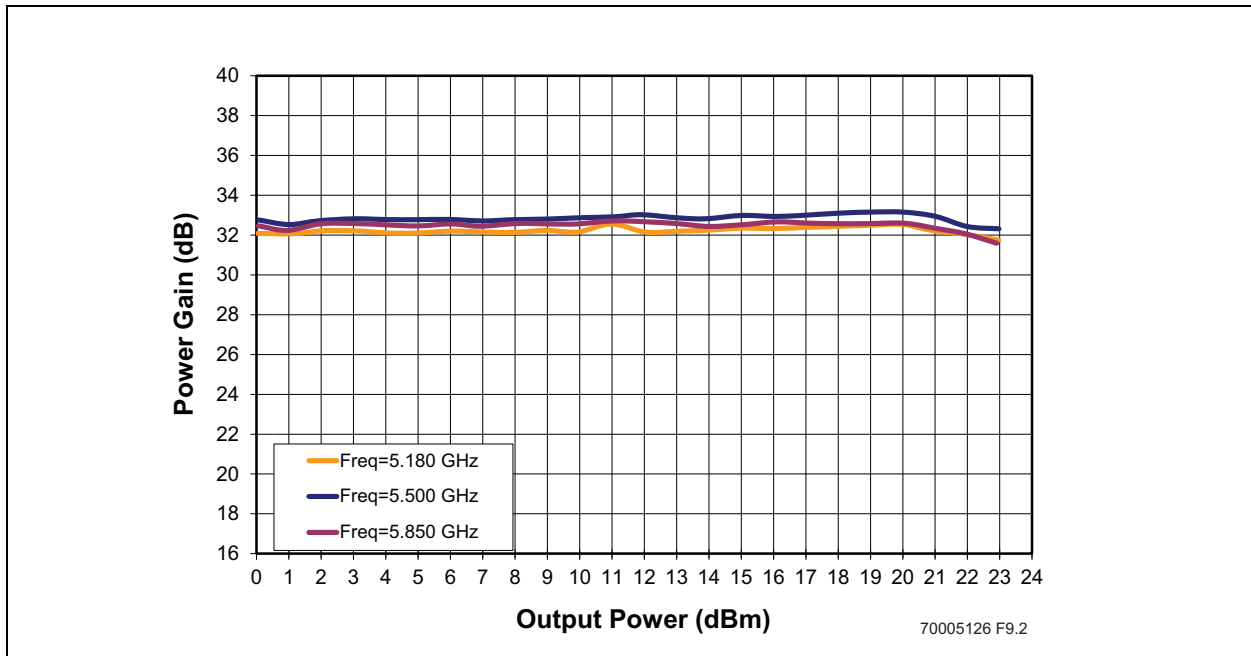

FIGURE 4-7: DETECTOR VOLTAGE VERSUS OUTPUT POWER,  $V_{PEN}=2.85V$

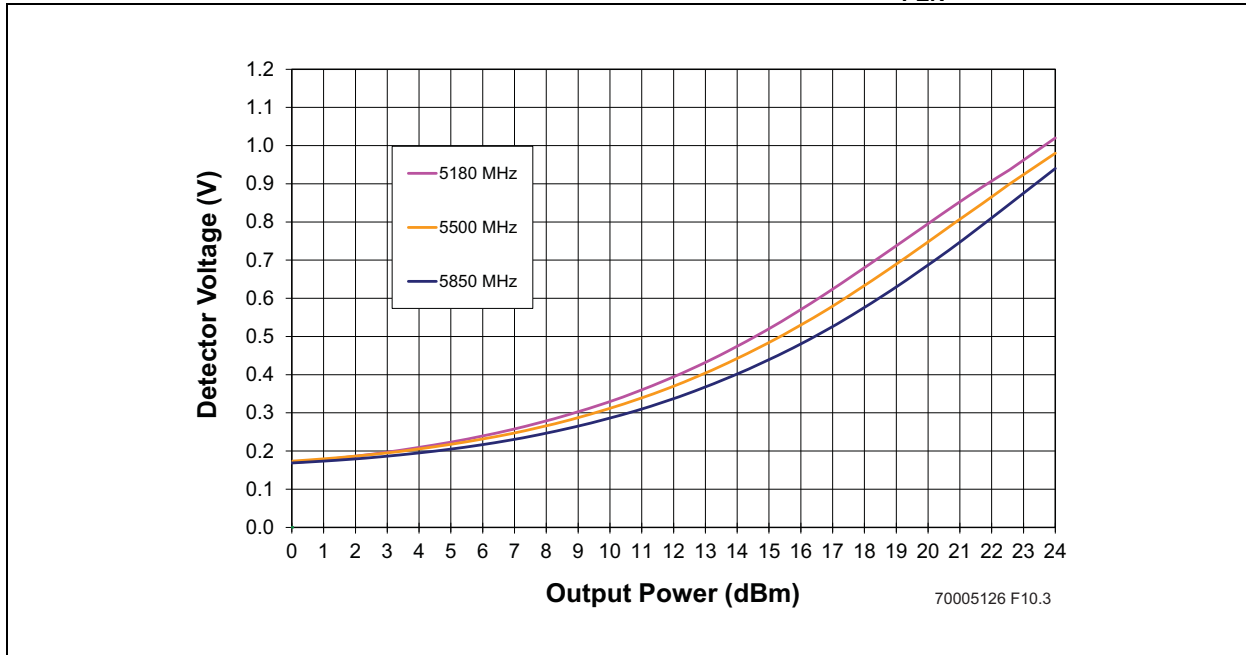
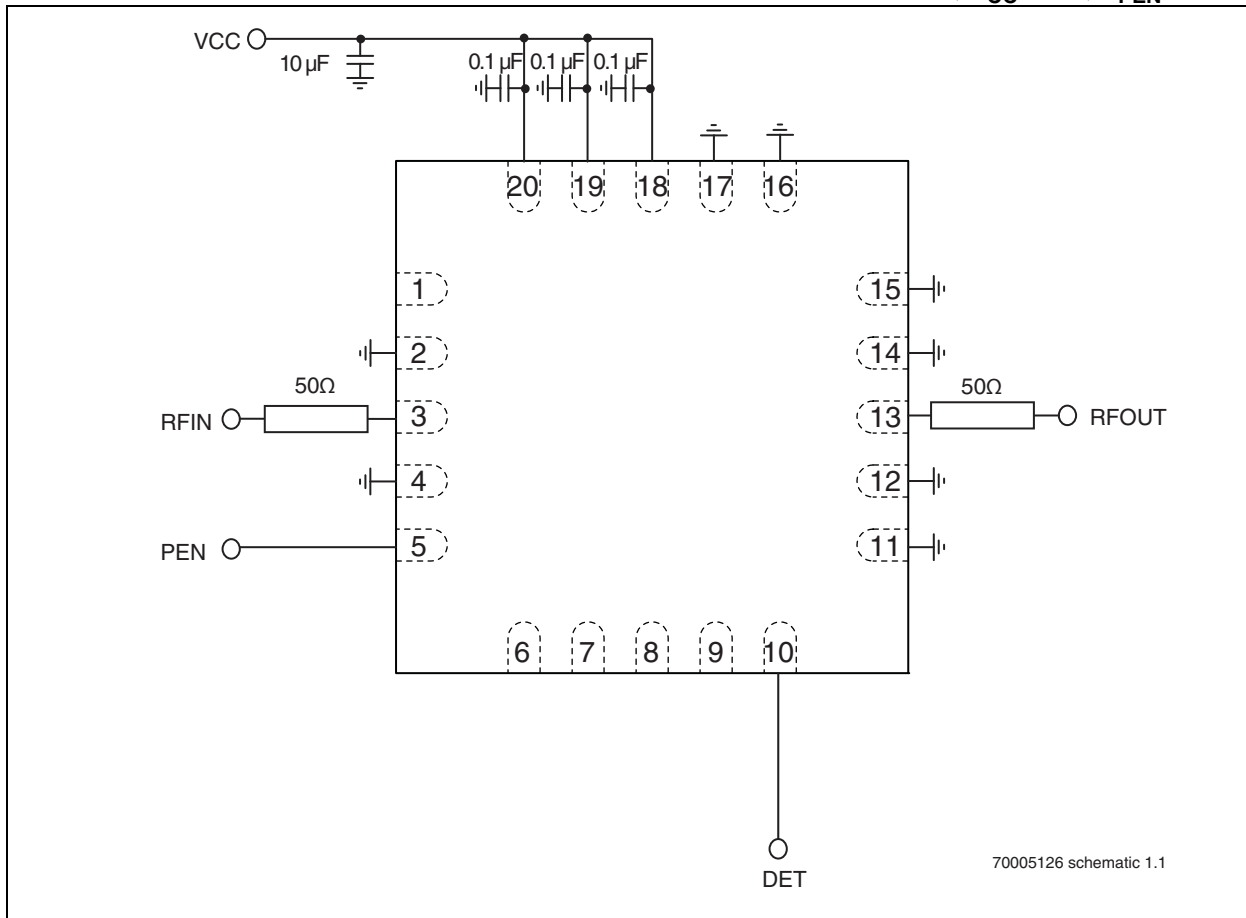

FIGURE 4-8: TYPICAL SCHEMATIC FOR 802.11a/n/ac APPLICATIONS,  $V_{CC}=5.0V$ ,  $V_{PEN}=2.85V$



5.0 PACKAGE INFORMATION

20-Lead Ultra Thin Quad Flat Pack, No Lead (GN) - 4x4x0.55 mm Body (UQFN)

**Note:** For the most current package drawings, please see the Microchip Packaging Specification located at <http://www.microchip.com/packaging>

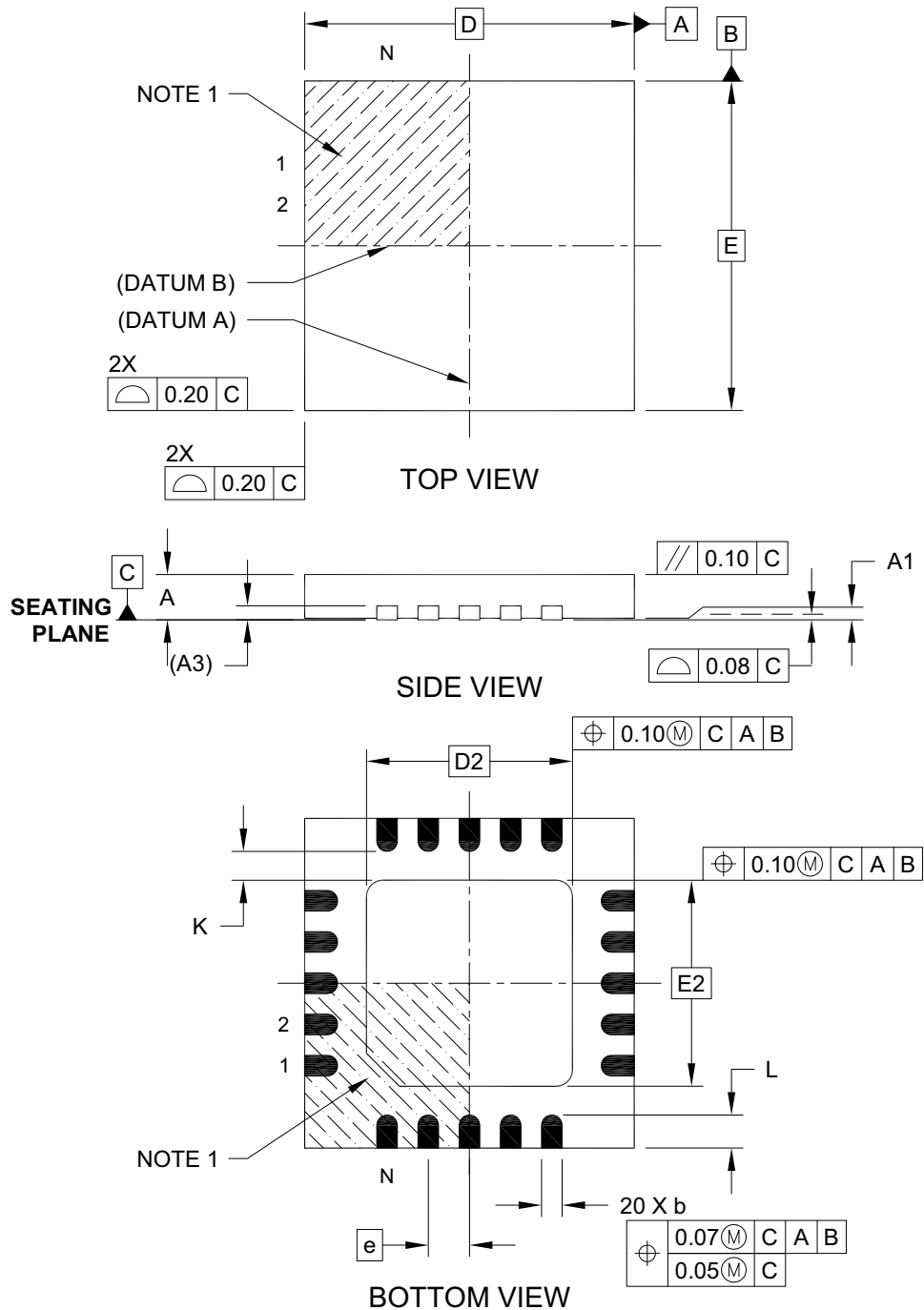

Microchip Technology Drawing C04-252A Sheet 1 of 2

## 20-Lead Ultra Thin Quad Flat Pack, No Lead (GN) - 4x4x0.55 mm Body (UQFN)

**Note:** For the most current package drawings, please see the Microchip Packaging Specification located at <http://www.microchip.com/packaging>

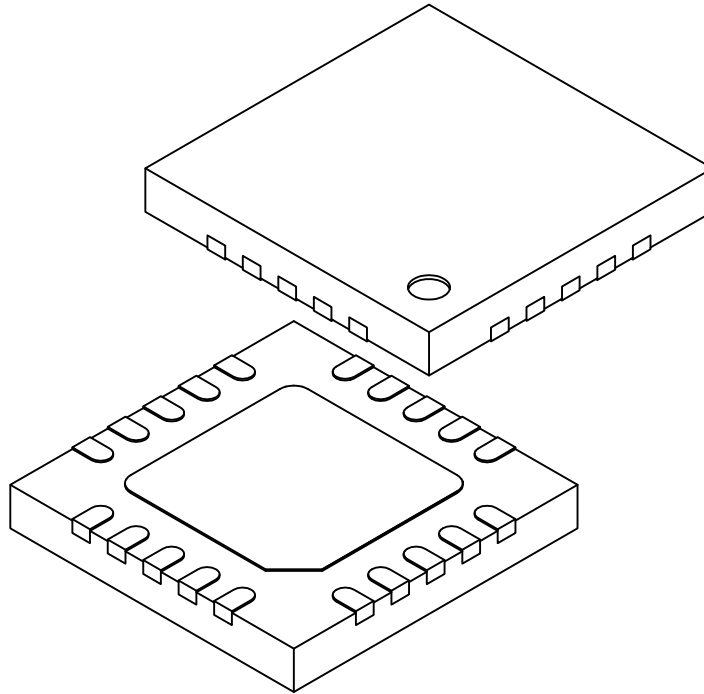

Dimension Limits	Units	MILLIMETERS		
		MIN	NOM	MAX
Number of Pins	N	20		
Pitch	e	0.50 BSC		
Overall Height	A	0.50	0.55	0.60
Standoff	A1	0.00	0.02	0.05
Terminal Thickness	(A3)	0.15 REF		
Overall Width	E	4.00 BSC		
Exposed Pad Width	E2	2.45	2.50	2.55
Overall Length	D	4.00 BSC		
Exposed Pad Length	D2	2.45	2.50	2.55
Terminal Width	b	0.20	0.25	0.30
Terminal Length	L	0.35	0.40	0.45
Terminal-to-Exposed-Pad	K	0.20	-	-

**Notes:**

1. Pin 1 visual index feature may vary, but must be located within the hatched area.
2. Package is saw singulated
3. Dimensioning and tolerancing per ASME Y14.5M
  - BSC: Basic Dimension. Theoretically exact value shown without tolerances.
  - REF: Reference Dimension, usually without tolerance, for information purposes only.

Microchip Technology Drawing C04-252A Sheet 2 of 2

TABLE 5-1: REVISION HISTORY

Revision	Description	Date
A	<ul style="list-style-type: none"><li>Initial release of data sheet</li></ul>	Jul 2013
B	<ul style="list-style-type: none"><li>Revised Product Description on page 1</li><li>Updated Figures 4-2 to 4-8</li><li>Updated Tables 3-2 and 3-3</li></ul>	Mar 2015

## THE MICROCHIP WEB SITE

Microchip provides online support via our WWW site at [www.microchip.com](http://www.microchip.com). This web site is used as a means to make files and information easily available to customers. Accessible by using your favorite Internet browser, the web site contains the following information:

- **Product Support** – Data sheets and errata, application notes and sample programs, design resources, user's guides and hardware support documents, latest software releases and archived software
- **General Technical Support** – Frequently Asked Questions (FAQs), technical support requests, online discussion groups, Microchip consultant program member listing
- **Business of Microchip** – Product selector and ordering guides, latest Microchip press releases, listing of seminars and events, listings of Microchip sales offices, distributors and factory representatives

## CUSTOMER CHANGE NOTIFICATION SERVICE

Microchip's customer notification service helps keep customers current on Microchip products. Subscribers will receive e-mail notification whenever there are changes, updates, revisions or errata related to a specified product family or development tool of interest.

To register, access the Microchip web site at [www.microchip.com](http://www.microchip.com). Under "Support", click on "Customer Change Notification" and follow the registration instructions.

## CUSTOMER SUPPORT

Users of Microchip products can receive assistance through several channels:

- Distributor or Representative
- Local Sales Office
- Field Application Engineer (FAE)
- Technical Support

Customers should contact their distributor, representative or field application engineer (FAE) for support. Local sales offices are also available to help customers. A listing of sales offices and locations is included in the back of this document.

**Technical support is available through the web site at: <http://microchip.com/support>**

## 6.0 PRODUCT IDENTIFICATION SYSTEM

To order or obtain information, e.g., on pricing or delivery, refer to the factory or the listed sales office.

<b>PART NO.</b>		<b>XXX</b>
<b>Device</b>	<b>Package</b>	
Device:	SST11CP22	= 51.-5.9 GHz Power Amplifier
Package:	GN	= UQFN (4mm x 4mm), 0.6 max thickness 20-contact
Evaluation Kit Flag	K	= Evaluation Kit

**Valid Combinations:**  
 SST11CP22-GN  
 SST11CP22-GN-K

---

**Note the following details of the code protection feature on Microchip devices:**

- Microchip products meet the specification contained in their particular Microchip Data Sheet.
- Microchip believes that its family of products is one of the most secure families of its kind on the market today, when used in the intended manner and under normal conditions.
- There are dishonest and possibly illegal methods used to breach the code protection feature. All of these methods, to our knowledge, require using the Microchip products in a manner outside the operating specifications contained in Microchip's Data Sheets. Most likely, the person doing so is engaged in theft of intellectual property.
- Microchip is willing to work with the customer who is concerned about the integrity of their code.
- Neither Microchip nor any other semiconductor manufacturer can guarantee the security of their code. Code protection does not mean that we are guaranteeing the product as “unbreakable.”

Code protection is constantly evolving. We at Microchip are committed to continuously improving the code protection features of our products. Attempts to break Microchip's code protection feature may be a violation of the Digital Millennium Copyright Act. If such acts allow unauthorized access to your software or other copyrighted work, you may have a right to sue for relief under that Act.

---

Information contained in this publication regarding device applications and the like is provided only for your convenience and may be superseded by updates. It is your responsibility to ensure that your application meets with your specifications. MICROCHIP MAKES NO REPRESENTATIONS OR WARRANTIES OF ANY KIND WHETHER EXPRESS OR IMPLIED, WRITTEN OR ORAL, STATUTORY OR OTHERWISE, RELATED TO THE INFORMATION, INCLUDING BUT NOT LIMITED TO ITS CONDITION, QUALITY, PERFORMANCE, MERCHANTABILITY OR FITNESS FOR PURPOSE. Microchip disclaims all liability arising from this information and its use. Use of Microchip devices in life support and/or safety applications is entirely at the buyer's risk, and the buyer agrees to defend, indemnify and hold harmless Microchip from any and all damages, claims, suits, or expenses resulting from such use. No licenses are conveyed, implicitly or otherwise, under any Microchip intellectual property rights.

#### **Trademarks**

The Microchip name and logo, the Microchip logo, dsPIC, FlashFlex, KEELOQ, KEELOQ logo, MPLAB, PIC, PICmicro, PICSTART, PIC<sup>32</sup> logo, rPIC, SST, SST Logo, SuperFlash and UNI/O are registered trademarks of Microchip Technology Incorporated in the U.S.A. and other countries.

FilterLab, Hampshire, HI-TECH C, Linear Active Thermistor, MTP, SEEVAL and The Embedded Control Solutions Company are registered trademarks of Microchip Technology Incorporated in the U.S.A.

Silicon Storage Technology is a registered trademark of Microchip Technology Inc. in other countries.

Analog-for-the-Digital Age, Application Maestro, BodyCom, chipKIT, chipKIT logo, CodeGuard, dsPICDEM, dsPICDEM.net, dsPICworks, dsSPEAK, ECAN, ECONOMONITOR, FanSense, HI-TIDE, In-Circuit Serial Programming, ICSP, Mindi, MiWi, MPASM, MPF, MPLAB Certified logo, MPLIB, MPLINK, mTouch, Omniclient Code Generation, PICC, PICC-18, PICDEM, PICDEM.net, PICkit, PICTail, REAL ICE, rLAB, Select Mode, SQI, Serial Quad I/O, Total Endurance, TSHARC, UniWinDriver, WiperLock, ZENA and Z-Scale are trademarks of Microchip Technology Incorporated in the U.S.A. and other countries.

SQTP is a service mark of Microchip Technology Incorporated in the U.S.A.

GestIC and ULPP are registered trademarks of Microchip Technology Germany II GmbH & Co. & KG, a subsidiary of Microchip Technology Inc., in other countries.

All other trademarks mentioned herein are property of their respective companies.

© 2015, Microchip Technology Incorporated, Printed in the U.S.A., All Rights Reserved.

 Printed on recycled paper.

ISBN: 978-1-63277-179-7

*Microchip received ISO/TS-16949:2009 certification for its worldwide headquarters, design and wafer fabrication facilities in Chandler and Tempe, Arizona; Gresham, Oregon and design centers in California and India. The Company's quality system processes and procedures are for its PIC<sup>®</sup> MCUs and dsPIC<sup>®</sup> DSCs, KEELOQ<sup>®</sup> code hopping devices, Serial EEPROMs, microperipherals, nonvolatile memory and analog products. In addition, Microchip's quality system for the design and manufacture of development systems is ISO 9001:2000 certified.*

---

**QUALITY MANAGEMENT SYSTEM  
CERTIFIED BY DNV  
= ISO/TS 16949 =**





---

## World Wide Sales and Service

---

### AMERICAS

**Corporate Office**  
2355 West Chandler Blvd.  
Chandler, AZ 85224-6199  
Tel: 480-792-7200  
Fax: 480-792-7277  
Technical Support:  
<http://www.microchip.com/support>  
Web Address:  
[www.microchip.com](http://www.microchip.com)

**Atlanta**  
Duluth, GA  
Tel: 678-957-9614  
Fax: 678-957-1455

**Austin, TX**  
Tel: 512-257-3370

**Boston**  
Westborough, MA  
Tel: 774-760-0087  
Fax: 774-760-0088

**Chicago**  
Itasca, IL  
Tel: 630-285-0071  
Fax: 630-285-0075

**Cleveland**  
Independence, OH  
Tel: 216-447-0464  
Fax: 216-447-0643

**Dallas**  
Addison, TX  
Tel: 972-818-7423  
Fax: 972-818-2924

**Detroit**  
Novi, MI  
Tel: 248-848-4000

**Houston, TX**  
Tel: 281-894-5983  
Indianapolis

**Noblesville, IN**  
Tel: 317-773-8323  
Fax: 317-773-5453

**Los Angeles**  
Mission Viejo, CA  
Tel: 949-462-9523  
Fax: 949-462-9608

**New York, NY**  
Tel: 631-435-6000

**San Jose, CA**  
Tel: 408-735-9110

**Canada - Toronto**  
Tel: 905-673-0699  
Fax: 905-673-6509

### ASIA/PACIFIC

**Asia Pacific Office**  
Suites 3707-14, 37th Floor  
Tower 6, The Gateway  
Harbour City, Kowloon

**Hong Kong**  
Tel: 852-2943-5100  
Fax: 852-2401-3431

**Australia - Sydney**  
Tel: 61-2-9868-6733  
Fax: 61-2-9868-6755

**China - Beijing**  
Tel: 86-10-8569-7000  
Fax: 86-10-8528-2104

**China - Chengdu**  
Tel: 86-28-8665-5511  
Fax: 86-28-8665-7889

**China - Chongqing**  
Tel: 86-23-8980-9588  
Fax: 86-23-8980-9500

**China - Dongguan**  
Tel: 86-769-8702-9880

**China - Hangzhou**  
Tel: 86-571-8792-8115  
Fax: 86-571-8792-8116

**China - Hong Kong SAR**  
Tel: 852-2943-5100  
Fax: 852-2401-3431

**China - Nanjing**  
Tel: 86-25-8473-2460  
Fax: 86-25-8473-2470

**China - Qingdao**  
Tel: 86-532-8502-7355  
Fax: 86-532-8502-7205

**China - Shanghai**  
Tel: 86-21-5407-5533  
Fax: 86-21-5407-5066

**China - Shenyang**  
Tel: 86-24-2334-2829  
Fax: 86-24-2334-2393

**China - Shenzhen**  
Tel: 86-755-8864-2200  
Fax: 86-755-8203-1760

**China - Wuhan**  
Tel: 86-27-5980-5300  
Fax: 86-27-5980-5118

**China - Xian**  
Tel: 86-29-8833-7252  
Fax: 86-29-8833-7256

### ASIA/PACIFIC

**China - Xiamen**  
Tel: 86-592-2388138  
Fax: 86-592-2388130

**China - Zhuhai**  
Tel: 86-756-3210040  
Fax: 86-756-3210049

**India - Bangalore**  
Tel: 91-80-3090-4444  
Fax: 91-80-3090-4123

**India - New Delhi**  
Tel: 91-11-4160-8631  
Fax: 91-11-4160-8632

**India - Pune**  
Tel: 91-20-3019-1500

**Japan - Osaka**  
Tel: 81-6-6152-7160  
Fax: 81-6-6152-9310

**Japan - Tokyo**  
Tel: 81-3-6880-3770  
Fax: 81-3-6880-3771

**Korea - Daegu**  
Tel: 82-53-744-4301  
Fax: 82-53-744-4302

**Korea - Seoul**  
Tel: 82-2-554-7200  
Fax: 82-2-558-5932 or  
82-2-558-5934

**Malaysia - Kuala Lumpur**  
Tel: 60-3-6201-9857  
Fax: 60-3-6201-9859

**Malaysia - Penang**  
Tel: 60-4-227-8870  
Fax: 60-4-227-4068

**Philippines - Manila**  
Tel: 63-2-634-9065  
Fax: 63-2-634-9069

**Singapore**  
Tel: 65-6334-8870  
Fax: 65-6334-8850

**Taiwan - Hsin Chu**  
Tel: 886-3-5778-366  
Fax: 886-3-5770-955

**Taiwan - Kaohsiung**  
Tel: 886-7-213-7828

**Taiwan - Taipei**  
Tel: 886-2-2508-8600  
Fax: 886-2-2508-0102

**Thailand - Bangkok**  
Tel: 66-2-694-1351  
Fax: 66-2-694-1350

### EUROPE

**Austria - Wels**  
Tel: 43-7242-2244-39  
Fax: 43-7242-2244-393

**Denmark - Copenhagen**  
Tel: 45-4450-2828  
Fax: 45-4485-2829

**France - Paris**  
Tel: 33-1-69-53-63-20  
Fax: 33-1-69-30-90-79

**Germany - Dusseldorf**  
Tel: 49-2129-3766400

**Germany - Munich**  
Tel: 49-89-627-144-0  
Fax: 49-89-627-144-44

**Germany - Pforzheim**  
Tel: 49-7231-424750

**Italy - Milan**  
Tel: 39-0331-742611  
Fax: 39-0331-466781

**Italy - Venice**  
Tel: 39-049-7625286

**Netherlands - Drunen**  
Tel: 31-416-690399  
Fax: 31-416-690340

**Poland - Warsaw**  
Tel: 48-22-3325737

**Spain - Madrid**  
Tel: 34-91-708-08-90  
Fax: 34-91-708-08-91

**Sweden - Stockholm**  
Tel: 46-8-5090-4654

**UK - Wokingham**  
Tel: 44-118-921-5800  
Fax: 44-118-921-5820

Компания «Океан Электроники» предлагает заключение долгосрочных отношений при поставках импортных электронных компонентов на взаимовыгодных условиях!

Наши преимущества:

- Поставка оригинальных импортных электронных компонентов напрямую с производств Америки, Европы и Азии, а так же с крупнейших складов мира;
- Широкая линейка поставок активных и пассивных импортных электронных компонентов (более 30 млн. наименований);
- Поставка сложных, дефицитных, либо снятых с производства позиций;
- Оперативные сроки поставки под заказ (от 5 рабочих дней);
- Экспресс доставка в любую точку России;
- Помощь Конструкторского Отдела и консультации квалифицированных инженеров;
- Техническая поддержка проекта, помощь в подборе аналогов, поставка прототипов;
- Поставка электронных компонентов под контролем ВП;
- Система менеджмента качества сертифицирована по Международному стандарту ISO 9001;
- При необходимости вся продукция военного и аэрокосмического назначения проходит испытания и сертификацию в лаборатории (по согласованию с заказчиком);
- Поставка специализированных компонентов военного и аэрокосмического уровня качества (Xilinx, Altera, Analog Devices, Intersil, Interpoint, Microsemi, Actel, Aeroflex, Peregrine, VPT, Syfer, Eurofarad, Texas Instruments, MS Kennedy, Miteq, Cobham, E2V, MA-COM, Hittite, Mini-Circuits, General Dynamics и др.);

Компания «Океан Электроники» является официальным дистрибьютором и эксклюзивным представителем в России одного из крупнейших производителей разъемов военного и аэрокосмического назначения «**JONHON**», а так же официальным дистрибьютором и эксклюзивным представителем в России производителя высокотехнологичных и надежных решений для передачи СВЧ сигналов «**FORSTAR**».



## JONHON

«**JONHON**» (основан в 1970 г.)

Разъемы специального, военного и аэрокосмического назначения:

(Применяются в военной, авиационной, аэрокосмической, морской, железнодорожной, горно- и нефтедобывающей отраслях промышленности)

«**FORSTAR**» (основан в 1998 г.)

ВЧ соединители, коаксиальные кабели,  
кабельные сборки и микроволновые компоненты:

(Применяются в телекоммуникациях гражданского и специального назначения, в средствах связи, РЛС, а так же военной, авиационной и аэрокосмической отраслях промышленности).



Телефон: 8 (812) 309-75-97 (многоканальный)

Факс: 8 (812) 320-03-32

Электронная почта: [ocean@oceanchips.ru](mailto:ocean@oceanchips.ru)

Web: <http://oceanchips.ru/>

Адрес: 198099, г. Санкт-Петербург, ул. Калинина, д. 2, корп. 4, лит. А