

*Electronics*

**Product Facts**

- Superior EMC/EMI Shielding Performance
- Simple installation
- Easy reentry
- Simplified maintenance and repair
- Excellent mechanical and environmental resistance
- Efficient strain relief
- Flexibility
- Versatility

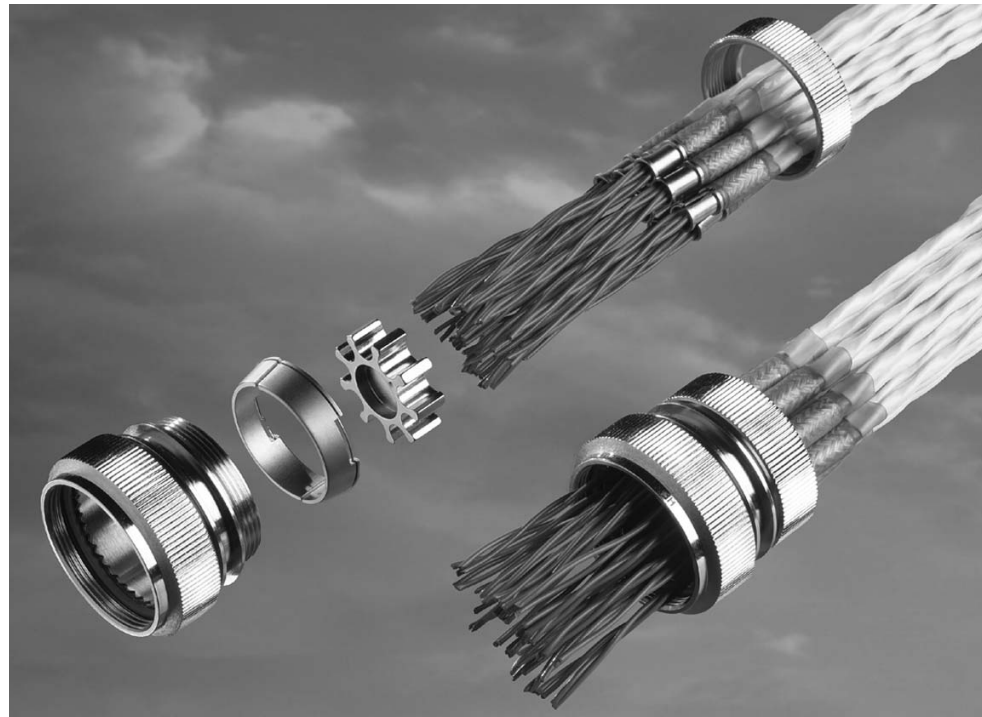

**Applications**

Tyco Electronics, a longtime leader in harnessing technology, has written a new chapter in EMC shielding with the introduction of the Raychem HexaShield EMC adapter.

Designed to provide EMC protection solutions for both commercial and military applications, HexaShield adapters represent a significant improvement over pigtail termination methods. By providing 360-degree EMC shielding on the termination area of each individual cable, HexaShield adapters provide outstanding shielding effectiveness.

HexaShield adapters are simple to install, easy to maintain, and dependably resistant to mechanical and environmental stresses.

**Principal points and features**

- Easy reentry: To insert or remove ferrules from the HexaShield adapter, simply loosen the back nut.
- Superior protection: No degradation of shielding performance.
- Up to four shielded cables accommodated by each ferrule.
- Mechanical and environmental protection equal to backshells complying with MIL-C-85049 Category 3B.
- Strain relief on each individual cable.
- Weight reduction, by possibly eliminating the need for overall shielding.
- Compact size - not exceeding outer diameter of connector.

- Available in straight, 45° and 90° angles, as well as swept and long bodies.

**Simple, one-piece assembly and installation**

1. Solder cable or wire shield to a ferrule with a Raychem heat-shrinkable SolderShield terminator.
2. Clip ferrule into one of the grounding star cavities.
3. Secure the back nut of the HexaShield adapter so that the conic ring assembly automatically compresses the ferrules.

Designed to corresponding connector specifications.

Platings Available*	Raychem Product Specifications
Electroless nickel (MIL-DTL-26074)	RB-110 and RB-114
Olive drab cadmium (QQ-P-416 Type II Class 3)	—
*Contact Tyco Electronics for additional platings	

**Installation Procedures**

Installation procedure for HET-A-02X and HET-A-04X (RPIP-696-00)	Installation procedure for HET-03X (RPIP-696-03)	General procedure for cylindrical connectors, right-angle body (RPIP-696-07)
General procedure for ARINC 600 Size II connectors (RPIP-696-01)	General procedure for cylindrical connectors, straight body (RPIP-696-04)	—
General procedure for ARINC 600 Size III connectors (RPIP-696-02)	—	—

**Hexashield Adapters for Circular Connectors: Straight, 45° and 90° Assemblies**

Item	Description
1	Straight adapter assembly
2	Conic ring assembly
3	Star Plain (Standard) Drilled (Option) Split (Option) _
4	Straight adapter assembly - "L" version - nominally 0.5" [12.7] longer body
5	45° adapter assembly - welded
6	45° adapter assembly - swept
7	90° adapter assembly - welded
8	90° adapter assembly - swept Standard products shown. Variants available on request. Split star assemblies are shown on relevant S.C.D's where applicable.

  

Item	HexaShield Version
-1	Back Nut
-2	Tinel adapter assembly Tinel-Lock ring for single braid
-3	Bandstrap adapter assembly
-C	Conduit adapter

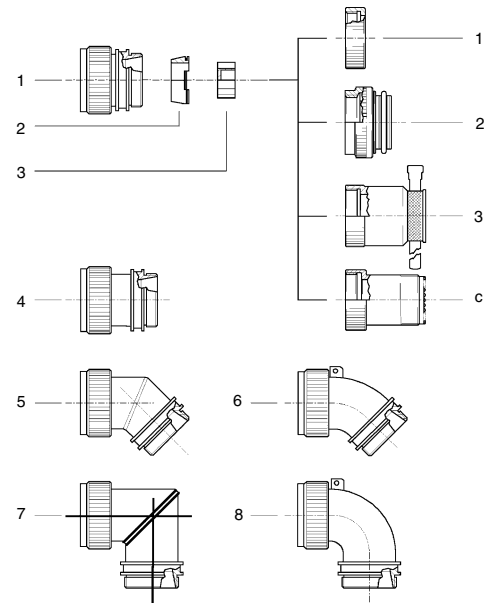

**HexaShield Adapters for ARINC 404/600 Connectors: Sizes 1, 2, 3 and 4 Assemblies**

Item	Description
1	Left side support
2	Right side support
3	Retention bars
4	Body assemblies Body Holding nut Conic ring assembly Star _ Back nut
5	Cavity plug assemblies Plug Holding nut
6	Pan head screws - 4-40 UNC
7	Spring washers

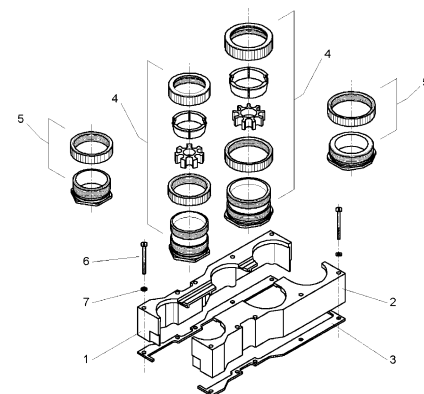

ARINC 600 Size 2 shown  
Stars are available as plain, drilled or split.  
See relevant S.C.D's for further information

Part Numbering for Standard Products

HexaShield Adapter for Circular Connectors

HEXYY L -AY -00 S -YY -AY -Y -DS

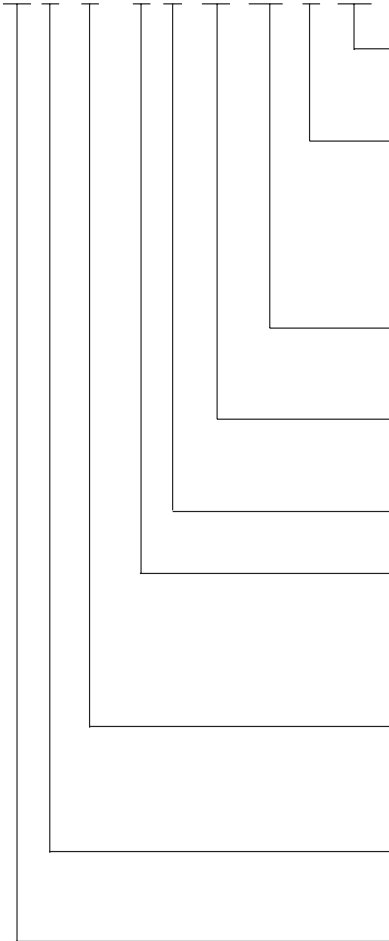

**Drilled Star:**

\*See applicable SCD for star options

**Type of Back Nut:**

- 1 = Standard back nut
- 2 = Clamping nut for tincl ring (for overbraid protection)
- 3 = Clamping nut with bandstrap
- C = Clamping nut for conduit applicator

Max. number of ferrules that can be accommodated

\*See applicable SCD for options

**Hexashield Size Code:**

\*See applicable SCD for order number (shell size)

S = Swept version

**Configuration:**

- 00 = Straight body
- 45 = 45 degree angle body
- 90 = 90 degree angle body

**Type of Plating:**

- B = Cadmium plated
- C = Electroless nickel

L = Long body

\*See applicable SCD for availability

**Connector Code Number:**

- 21 = MIL-C-26482 Series 1
- 40 = MIL-DTL-38999 Series 3 and 4
- 41 = MIL-DTL-38999 Series 1 and 2
- 54 = MIL-DTL-38723 Series 1 and 3
- MIL-C-25482 Series 2

Ordering Information (Continued)

HexaShield Adapter for Collins Connectors

HEXDB-AC-00-A9-1

00 = Straight body  
90 = Right-angle body

HexaShield Adapter for ARINC 600 Connectors

HEXA6-AY-00-YY-AY-Y

**Clamping nut version:**  
1 = Clamping nut alone  
2 = Clamping nut for tinel ring

**Number of ferrules:**  
18 for ARINC 600 size II (A and B cavities)  
25 for ARINC 600 size II (A, B and C cavities)  
18 for ARINC 600 size III (A and B cavities)  
\*See applicable SCD for options

**ARINC Connector Size:**  
02 = ARINC 600 size II  
03 = ARINC 600 size III

**Configuration:**  
00 = Straight body  
90 = Right-angle body

**Plating:**  
B = Cadmium plated  
C = Electroless nickel

Part Numbering of Ferrule Kits

**HET-A-02X** for small-size cable with SolderShield terminator  
**HET-A-03X** for connection of unshielded cables  
ferrules with heat-shrinkable tubing (no shield)  
**HET-A-04X** for large-size cables with SolderShield terminator

**Type of Plating:**  
B = Cadmium plated  
C = Electroless nickel

**HEX07-AX** ferrule - solid blank for use when a HET-A is not needed

**Type of Plating:**  
B = Cadmium plated  
C = Electroless nickel

\*Not all part numbers are standard; your local Tyco Electronics representative will assist you in selecting the appropriate standard product

Trim off for 3-hole punch

**Product Facts**

- Outperforms traditional pigtail termination, especially in HIRF performance
- Withstands 10-kA peak current lightning transients of SAE AE4L-87-3

**Transfer Impedance**

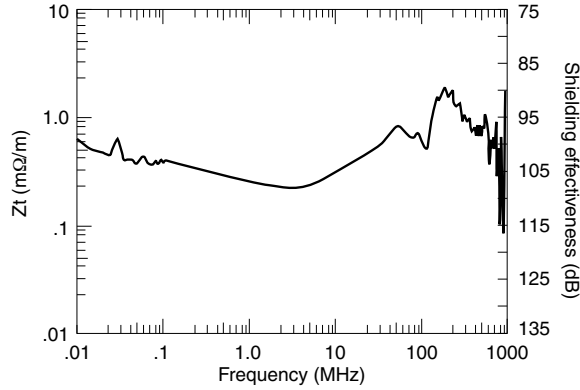

HexaShield size: 23

Cable: Raychem 5024H8424  
(one cable installed)

Test method: CEI 96-1

**Protection Level**

Generalized system performance (Actual system performance in any one test method may differ.)

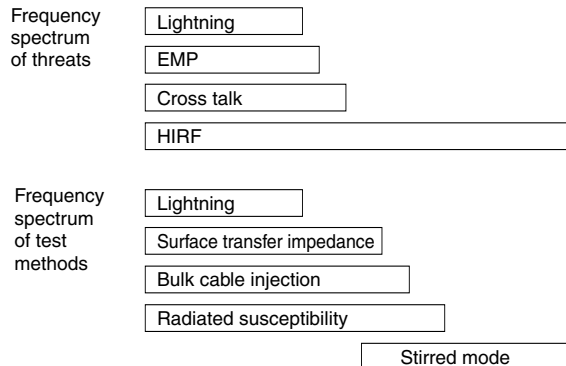
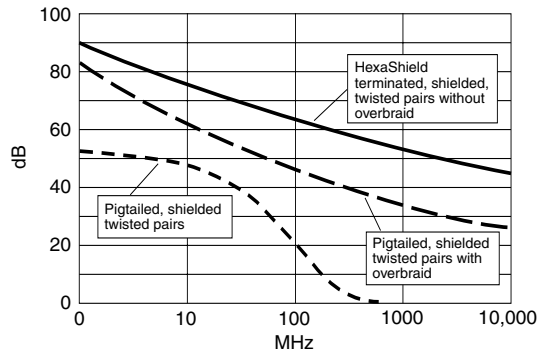

Trim off for 3-hole punch

*Electronics*

**Typical HexaShield Applications**

Civilian and military aircraft
Avionics
Fighter aircraft
Missiles and launch support systems
Armored and military support vehicles
Navy ships (total shipboard hardening)
Military communications
Engines (FADEC harness hardening)

**HexaShield Product Range**

Accommodates the following connector types*:
MIL-C-26482 Series 1
MIL-DTL-38999 Series 1, 2, 3, and 4
MIL-C-26482 Series 2
MIL-DTL-83723 Series 1 and 3
DBAD
ARINC 600
ARINC 404

\*Please contact Tyco Electronics for other connector types and special requests.

**Support Services**

	<b>United States</b>	<b>Canada</b>	<b>Mexico</b>	<b>Central America</b>	<b>South America</b>	<b>Other Latin/South American Countries</b>
<b>Technical Support</b>	1-800-522-6752	1-905-470-4425	01-800-733-8926	52-55-5-729-0425	55-11-3611-1514	57-1-240-9396
<b>Tooling Assistance</b>	1-800-522-6752	1-905-470-4425	01-800-733-8926	52-55-5-366-0224	55-11-4034-6021	57-1-240-9396
<b>Customer Service</b>	1-800-522-6752	1-905-475-6222	01-800-733-8926	52-55-5-729-0431	55-11-3611-1311	57-1-240-9396
<b>Product Information by FAX</b>	1-800-522-6752	1-800-245-4356	01-800-733-8926	52-55-5-729-0431	1-717-986-3500	57-1-240-9396

Компания «Океан Электроники» предлагает заключение долгосрочных отношений при поставках импортных электронных компонентов на взаимовыгодных условиях!

Наши преимущества:

- Поставка оригинальных импортных электронных компонентов напрямую с производств Америки, Европы и Азии, а так же с крупнейших складов мира;
- Широкая линейка поставок активных и пассивных импортных электронных компонентов (более 30 млн. наименований);
- Поставка сложных, дефицитных, либо снятых с производства позиций;
- Оперативные сроки поставки под заказ (от 5 рабочих дней);
- Экспресс доставка в любую точку России;
- Помощь Конструкторского Отдела и консультации квалифицированных инженеров;
- Техническая поддержка проекта, помощь в подборе аналогов, поставка прототипов;
- Поставка электронных компонентов под контролем ВП;
- Система менеджмента качества сертифицирована по Международному стандарту ISO 9001;
- При необходимости вся продукция военного и аэрокосмического назначения проходит испытания и сертификацию в лаборатории (по согласованию с заказчиком);
- Поставка специализированных компонентов военного и аэрокосмического уровня качества (Xilinx, Altera, Analog Devices, Intersil, Interpoint, Microsemi, Actel, Aeroflex, Peregrine, VPT, Syfer, Eurofarad, Texas Instruments, MS Kennedy, Miteq, Cobham, E2V, MA-COM, Hittite, Mini-Circuits, General Dynamics и др.);

Компания «Океан Электроники» является официальным дистрибьютором и эксклюзивным представителем в России одного из крупнейших производителей разъемов военного и аэрокосмического назначения «JONHON», а так же официальным дистрибьютором и эксклюзивным представителем в России производителя высокотехнологичных и надежных решений для передачи СВЧ сигналов «FORSTAR».



## JONHON

«JONHON» (основан в 1970 г.)

Разъемы специального, военного и аэрокосмического назначения:

(Применяются в военной, авиационной, аэрокосмической, морской, железнодорожной, горно- и нефтедобывающей отраслях промышленности)

«FORSTAR» (основан в 1998 г.)

ВЧ соединители, коаксиальные кабели, кабельные сборки и микроволновые компоненты:

(Применяются в телекоммуникациях гражданского и специального назначения, в средствах связи, РЛС, а так же военной, авиационной и аэрокосмической отраслях промышленности).



Телефон: 8 (812) 309-75-97 (многоканальный)

Факс: 8 (812) 320-03-32

Электронная почта: [ocean@oceanchips.ru](mailto:ocean@oceanchips.ru)

Web: <http://oceanchips.ru/>

Адрес: 198099, г. Санкт-Петербург, ул. Калинина, д. 2, корп. 4, лит. А