

### SX1240 - Low Cost Integrated Transmitter IC 434 MHz and 868 MHz Band RF Transmitter

#### GENERAL DESCRIPTION

The SX1240 is an ultra-low-cost, fully integrated FSK or OOK compatible transmitter suitable for operation in the 418, 434 and 868 MHz licence free ISM bands.

For applications where economy is paramount, the SX1240 may be used without the requirement for configuration via an MCU. The transmitter is configured for default operation at a frequency of 433.92 MHz or 868.3 MHz. However, in conjunction with a microcontroller the communication link parameters may be re-configured. Including, output power, modulation format and operating channel.

The SX1240 offers integrated radio performance with cost efficiency and is suited for worldwide operations in particular Europe (ETSI EN 300-220-1), North America (FCC part 15.231).

#### ORDERING INFORMATION

Part Number	Temperature Range	Qty. per Reel	Package
SX1240ISTR1	-40 °C to +85 °C	2500	SOIC8-EP

Pb-Free, Halogen Free, RoHS/WEEE compliant product.

#### APPLICATIONS

- ◆ Low-Cost Consumer Electronic Applications
- ◆ Remote Keyless Entry (RKE)
- ◆ Remote Control / Security Systems
- ◆ Audio Accessories
- ◆ Process and building / home control
- ◆ Active RFID

#### KEY PRODUCT FEATURES

- ◆ +10 dBm or 0 dBm Configurable output power
- ◆ Bit rates up to 100 kbps
- ◆ FSK and OOK modulation
- ◆ 2 Preconfigured Modes for Operation without MCU  
433.92 MHz OOK & 868.3 MHz FSK
- ◆ 1.8 to 3.7 V supply range
- ◆ Low BOM Fully Integrated Tx
- ◆ 8 Selectable Centre Frequencies
- ◆ Programmable Frequency Tuning of low cost XTAL

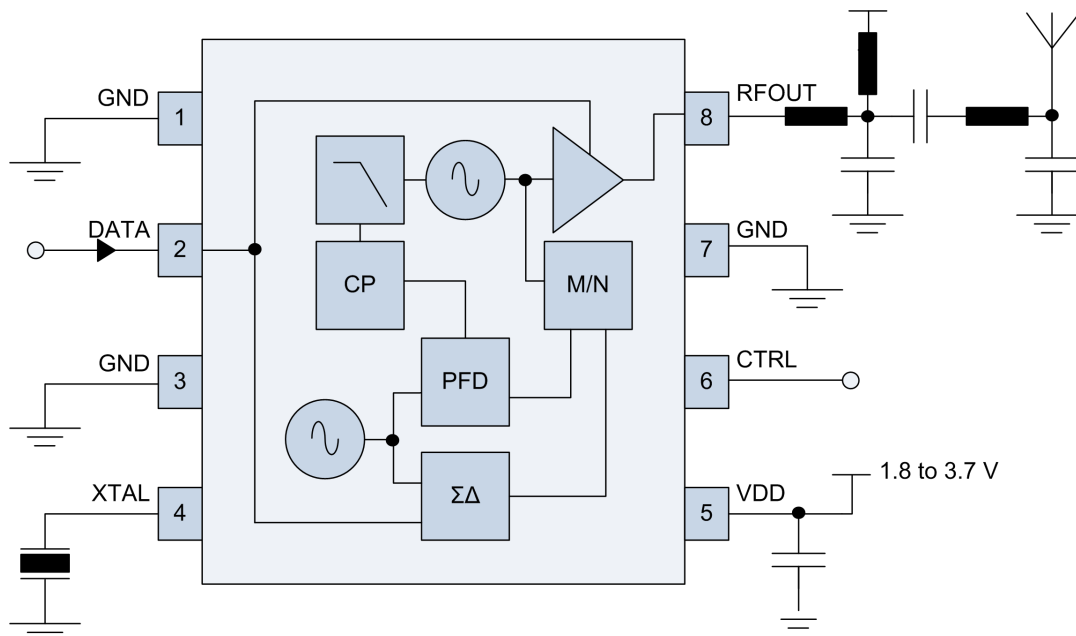

**Table of contents**

<b>Section</b>	<b>Page</b>
1. General Description .....	3
1.1. Pin Diagram .....	3
1.2. Marking Diagram.....	4
1.3. Pin Description.....	4
2. Electrical Characteristics .....	5
2.1. ESD Notice .....	5
2.2. Absolute Maximum Ratings .....	5
2.3. Operating Range.....	5
2.4. Electrical Specifications	6
2.5. Timing Characteristics .....	7
3. Application Modes .....	8
3.1. Application Mode: Power & Go 9	
3.1.1. 'Power & Go' Mode: Configuration.....	9
3.1.2. Transmitter Operation in 'Power & Go' Mode .....	9
3.2. Application Mode: Advanced .....	10
3.2.1. Advanced Mode: Configuration.....	10
3.2.2. Transmitter Operation in Advanced Mode .....	11
4. Configuration Register .....	13
5. Application Information .....	14
5.1. Crystal Specification .....	14
5.2. Reference Design Schematics.....	14
5.3. Reference Design PCB Layout	15
5.4. Reference Design BOM	16
6. Packaging Information .....	17
6.1. Package Outline Drawing .....	17
6.2. Land Pattern .....	17
6.3. Tape & Reel Specification.....	18
7. Revision History.....	19

This product datasheet contains a detailed description of the SX1240 performance and functionality.

## 1. General Description

The SX1240 is a fully-integrated frequency-agile, single chip transmitter IC capable of FSK and OOK modulation of an input data stream. The full application circuit is shown in Figure 9. The SX1240 is configured, by default, to operate without a microcontroller with its pre-configured RF settings (see Section 3 for precise details of the default settings). Selection is made between 434 MHz and 868 MHz band operation by setting the Control pin (6) either high or low at power-up. A full description of this functionality is given in Section 3.1.

Where greater flexibility is required, many of the default communication parameters can be dynamically configured. This includes the operating frequency, frequency deviation and modulation format. Upon the application of a serial clock to the Control pin (6), the Data pin (2) can be used to load a single 13-bit control word. Accessing this functionality is subject to the connection of the control pin at start-up. For full details of this, the configuration bits and the precise timing operations of this functionality please consult Section 3.2.

The SX1240 is designed for use with a variety of low-cost antenna technologies. A reference design with PCB-trace antenna is presented in Section 5.

Another key feature of the SX1240 is its low current consumption in transmit and sleep modes and its wide voltage operating range from 1.8 V to 3.7 V. This makes the SX1240 suitable for low-cost battery chemistries or energy harvesting applications.

The internal architecture of the SX1240 is shown in Figure 1. The SX1240 comprises a low-consumption PLL and power amplifier. For frequency modulation the modulation is performed digitally within the PLL bandwidth. OOK Modulation is performed via ramping of the PA reference DAC.

### 1.1. Pin Diagram

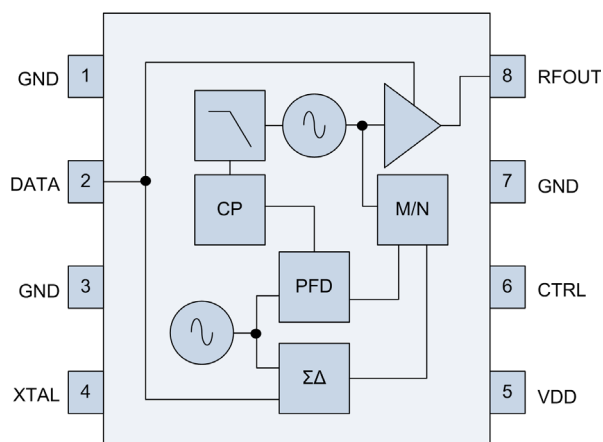

Figure 1. Pinouts, Top View

## 1.2. Marking Diagram

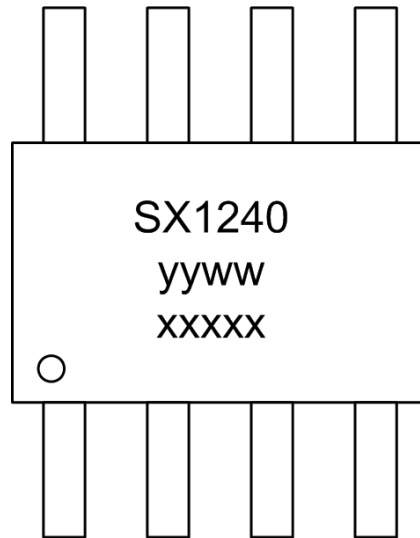

Figure 2. Marking Diagram

Notes yyww refers to the date code  
 xxxxx refers to the lot number

## 1.3. Pin Description

Table 1 Description of the SX1240 Pinouts

Number	Name	Type	Function in 'Power & Go' Mode	Function in 'Advanced' Mode
1	GND	I	Ground	
2	DATA	I/O	Transmit Data	Transmit or Configuration Data
3	GND	I	Ground	
4	XTAL	I/O	Reference Crystal	
5	VDD	I	Power Supply 1.8V to 3.7V	
6	CTRL	I	Config Selection	Configuration Data Clock
7	GND	I	Ground	
8	RFOUT	O	Transmitter RF Output	

## 2. Electrical Characteristics

### 2.1. ESD Notice

The SX1240 is a high performance radio frequency device, and satisfies Class 2 of the JEDEC standard JESD22-A114-B (human body model) on all pins.

It should thus be handled with all necessary ESD precautions to avoid any permanent damage.



### 2.2. Absolute Maximum Ratings

Stresses above the values listed below may cause permanent device failure. Exposure to absolute maximum ratings for extended periods may affect device reliability.

Table 2 Absolute Maximum Ratings

Symbol	Description	Min	Max	Unit
VDDmr	Supply Voltage	-0.5	3.9	V
Tmr	Temperature	-55	+115	° C
Tjunc	Junction Temperature	-55	+125	° C
Tstor	Storage Temperature	-55	150	° C

### 2.3. Operating Range

Operating ranges define the limits for functional operation and the parametric characteristics of the device as described in this section. Functionality outside these limits is not implied.

Table 3 Operating Range

Symbol	Description	Min	Max	Unit
VDDop	Supply voltage	1.8	3.7	V
Top	Operational temperature range	-40	85	° C
Clop	Load capacitance on digital ports	-	25	pF

### 2.4. Electrical Specifications

The table below gives the electrical specifications of the transmitter under the following conditions: Supply voltage = 3.3 V, temperature = 25 °C,  $f_{XOSC}$  = 26 MHz,  $f_{RF}$  = 433.93 MHz, 2-level FSK modulation  $Df$  = 20 kHz, bit rate = 10 kbit/s and output power = +10 dBm terminated in a matched 50 ohm impedance, unless otherwise specified.

Table 4 Transmitter Specifications

Symbol	Description	Conditions	Min	Typ	Max	Unit
<b>Current Consumption</b>						
IDDSL	Supply current in sleep mode		-	0.5	1	µA
IDDT	Supply current in transmit mode with appropriate external matching.	RF Power o/p = +10 dBm RF Power o/p = 0 dBm	- -	16.5 9	- -	mA mA
<b>RF and Baseband Specifications</b>						
FDA_D	Frequency deviation, FSK	Number of programmable values	-	8	-	
FDA	Frequency deviation, FSK*		10	-	100	kHz
BRF	Bit rate, FSK	Permissible Range	0.5	-	100	kbps
BRO	Bit rate, OOK	Permissible Range	0.5	-	10	kbps
OOK_B	OOK Modulation Depth		-	50	-	dB
RFOP	RF output power in 50 ohms	High Power Setting Low Power Setting**	7 -3	10 0	- -	dBm dBm
DRFOPV	Variation in RF output power with supply voltage	2.5 V to 3.3 V 1.8 V to 3.7 V	- -	- -	3 7	dB dB
PHN	Transmitter phase noise at 868.3 MHz	Offset from centre frequency: 100 kHz 350 kHz 550 kHz 1.15 MHz	- - - -	- - - -	-76 -81 -91 -101	dBc/Hz dBc/Hz dBc/Hz dBc/Hz
FR	Number of selectable Frequencies		-	8	-	
FXOSC	Crystal Oscillator Frequency		26	26	26	MHz
STEP	RF Frequency Step	868 MHz 434 MHz	- -	3.174 1.587	- -	kHz kHz
DFXOSC	Frequency Variation of the Oscillator Circuit	No crystal contribution	-	-	+/-25	ppm
<b>Timing Specifications</b>						
TS_TR	Time from Sleep to Tx mode		-	-	2	ms
TOFFT	Timer from Tx data activity to Sleep	Programmable	- -	2 20	- -	ms ms
RAMP	PA Ramp up and down time	****	-	20	-	us

Symbol	Description	Conditions	Min	Typ	Max	Unit
T_START	Time before CTRL pin mode selection.	Time from power on to sampling of CTRL ***	-	200 us + TS_OSC	-	ms

\* Frequency deviation is positive (+FDA) with DATA = '1', negative (-FDA) with DATA = '0'

\*\* With two different matching networks

\*\*\* The oscillator startup time, TS\_OSC, depends on the electrical characteristics of the crystal

\*\*\*\* Ramp-up time of the internal regulator turning the PA on. The typical 10% - 90% power ramp-up time is 10us

## 2.5. Timing Characteristics

The following table gives the operating specifications for the TWI interface of the SX1240.

*Table 5 Serial Interface Timing Specifications*

Symbol	Description	Conditions	Min	Typ	Max	Unit
f_ctrl	CTRL Clock Frequency		-	-	10	MHz
t_ch	CTRL Clock High time		45	-	-	ns
t_cl	CTRL Clock Low time		45	-	-	ns
t_rise	CTRL Clock rise time		-	-	5	ns
t_fall	CTRL Clock Fall time		-	-	5	ns
t_setup	DATA Setup time	From Data transition to CTRL rising edge	45	-	-	ns
t_hold	DATA hold time	From CTRL rising edge to DATA transition	45	-	-	ns

### 3. Application Modes

The SX1240 has two application modes. These are selected depending upon the load presented to the Control pin (6) at power-on of the device, as shown on Figure 3. By connecting the Control pin to logical '0' or '1' the Power & Go mode is selected. A full description of operation in this mode is given in Section 3.1. By presenting a logical zero to the Control input, Advanced Mode can be accessed by subsequent clocking of the control pin, in conjunction with the Data pin (2) permits programming of the SX1240 configuration register and manual control of the transmitter. For more information on Advanced Mode operation please consult Section 3.2. The diagram below summarises the mode selection process.

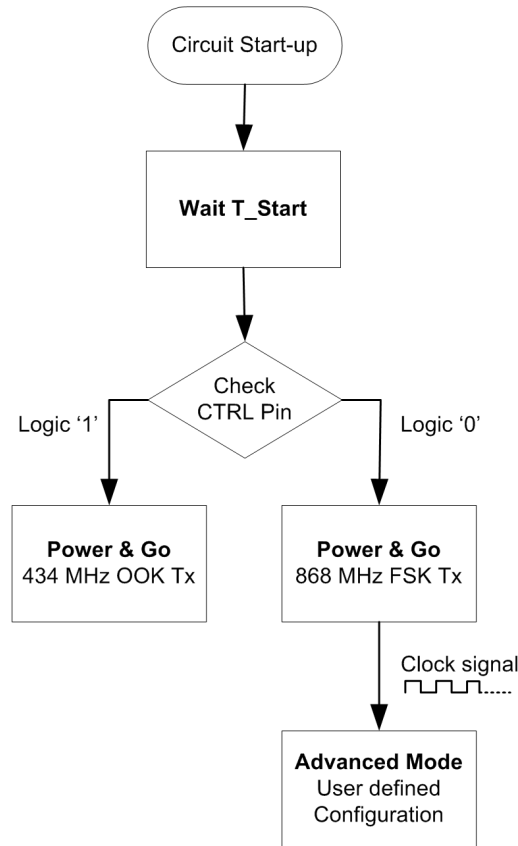

Figure 3. SX1240 Mode Selection

Table 6 Control Pin Selection of the Application Mode

CTRL Pin (6)	Application Mode
Logic '1' or '0'	Power & Go Mode (see Section 3.1)
Logic '0' then Clock on CTRL	Advanced Mode (see Section 3.2)



### 3.1. Application Mode: Power & Go

#### 3.1.1. 'Power & Go' Mode: Configuration

The default Power & Go application mode sees the SX1240 configured as detailed in the following table. By changing the logical state of the control pin (6) at power-up, one of a pair of default configuration modes can be selected. The Power & Go application mode hence permits microcontroller-less operation. By simply powering the transmitter application circuit, the SX1240 is pre-configured as either a 434 MHz OOK transmitter or an 868 MHz FSK transmitter. For appropriate matching circuits please see Section 5.

Table 7 Configuration and Band Selection in Power & Go Application Mode

CTRL (Pin 6)	Configuration
'High'	OOK 433.92 MHz, 10 dBm
'Low'	FSK 868.3 MHz, Fdev = 20 kHz, 10 dBm

#### 3.1.2. Transmitter Operation in 'Power & Go' Mode

The timing of a typical transmit operation in Power & Go mode is shown in Figure 4. Here we see that a rising edge on the DATA pin activates the transmitter start-up process. DATA must then be held high for the start-up time (TS\_TR) of the SX1240. During this time the SX1240 undergoes an optimized, self-calibrating, trajectory from sleep mode to transmit mode. Once this time has elapsed, the SX1240 is ready to transmit. Any logical signal subsequently applied to the DATA pin is then transmitted.

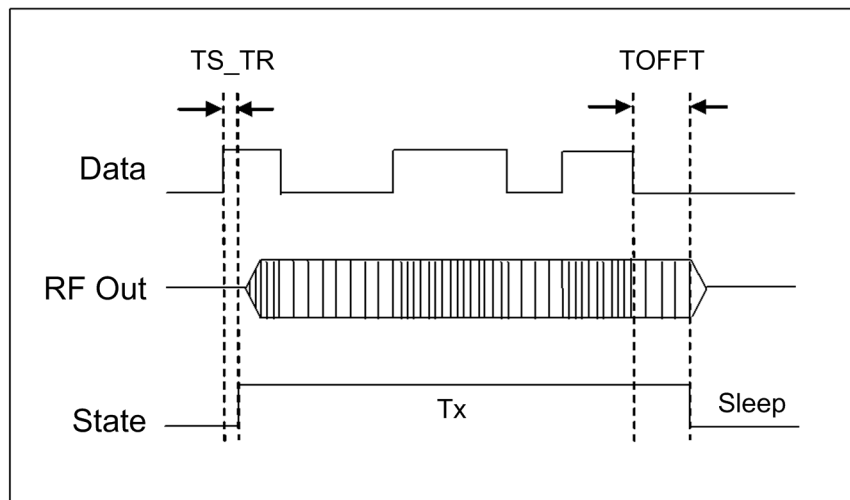

Figure 4. 'Power & Go' Mode: Transmitter Timing Operation

The transition back to sleep mode is managed automatically. In 868 MHz FSK modulation mode, after 2 ms of inactivity on the DATA line, the SX1240 returns to sleep mode. If in 434 MHz, OOK modulation mode, the SX1240 waits for 20 ms of inactivity before returning to sleep mode.

### 3.2. Application Mode: Advanced

#### 3.2.1. Advanced Mode: Configuration

Advanced mode can be accessed as described on Figure 3. Programming is performed via a two wire interface (TWI) formed by CTRL and DATA pins.

Programming of the configuration register is triggered by a rising edge on the CTRL line. Upon detection of this rising edge, the data applied to the DATA pin is accepted as register configuration information, the data bits are clocked on subsequent rising edges of the clocking signal applied to the CTRL pin. The first bit of serial data selects register read or write operation (Read = 'high' and Write = 'low'). The timing for SX1240 configuration register 'write' is shown in Figure 5. Note that, once triggered, all 13 data bits must be written to the SX1240.

The contents of the configuration register and the role of each bit therein is described in Table 8 of Section 4.

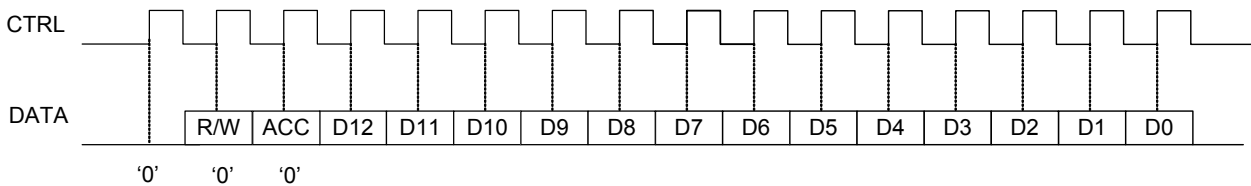

*Figure 5. TWI Configuration Register 'Write'.*

Similarly, the configuration register may be read using the timing of Figure 6.

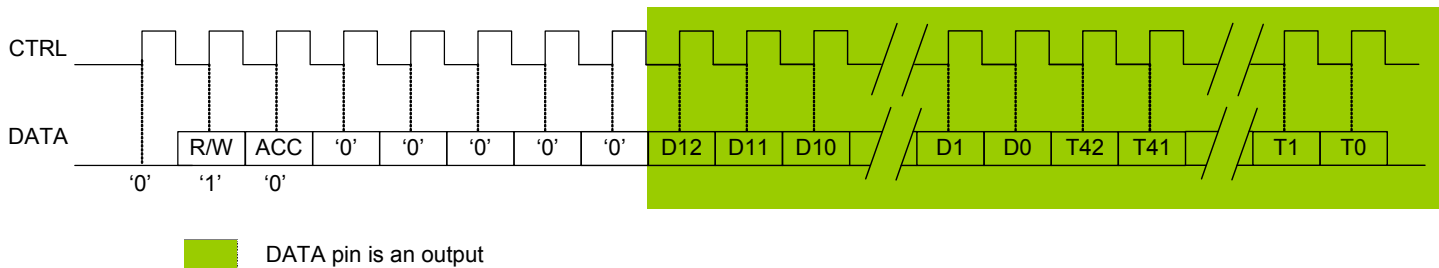

*Figure 6. TWI Configuration Register 'Read'.*

- Notes**
- Logic level '0' on DATA during the first rising edge on CTRL is required to start the TWI access
  - Reading only the 13 configuration bits D0 to D12 is not allowed on the SX1240. In Read access, 64 clock cycles on CTRL pin must be issued, shifting out on pin DATA the 13 configuration bits (D0 to D12), plus 43 internal test bits (T0 to T42). Read access should be used when developing the device firmware, but is not intended for use in the normal operation mode.
  - During the register 'write' or 'read' phases the SX1240 remains in sleep mode.

When powering up the circuit (microcontroller and SX1240), the logic level of the CTRL pin is sampled after  $T\_START$ , as described on Figure 3. During  $T\_START$ , the microcontroller IO driving the CTRL pin must be configured as an output, driving the CTRL pin to the desired state.

*Note* whilst the logic level of CTRL pin during  $T\_START$  (initialization phase of the microcontroller) does not have any effect on the device operation, the pin should not be connected to VDD through an impedance lower than 20 k ohms or higher than 1 M ohms.

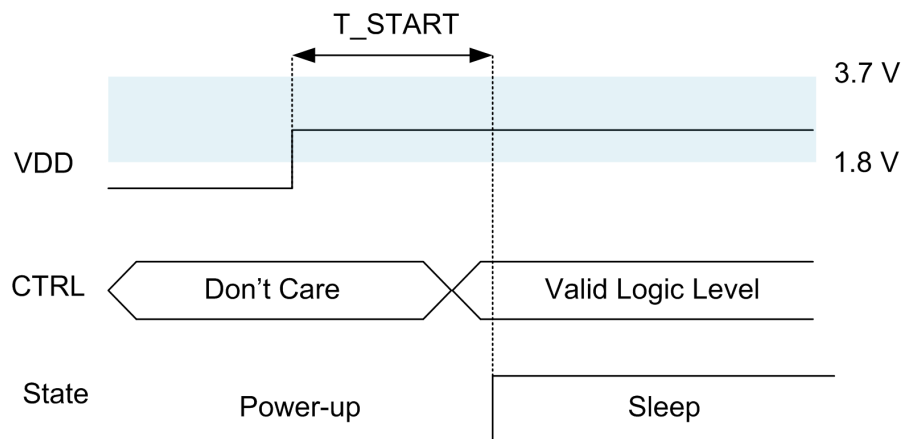

Figure 7. Power-up Timing

### 3.2.2. Transmitter Operation in Advanced Mode

When operating in advanced mode two possibilities exist for operation of the transmitter, these are dependent upon the state of the Tx Mode bit (D12 of the register description in Table 8).

#### Tx Mode = '0'

When set to logical '0' operation is identical to that of the Power & Go mode, following completion of the programming phase, the SX1240 will be placed in transmit mode upon the next rising edge detected on the DATA pin. Transmit operation will then be in accordance with that of Figure 4 with the time  $TOFFT$  corresponding to that programmed.

Note that prior to programming the default, logical '0', configuration is loaded. Note also that subsequent programming iterations can only be performed once the transmit cycle is finished - including the time required for switching off the PA ( $TOFFT$ ).

#### Tx Mode = '1'

With Tx Mode (D12) set to '1' during the register programming cycle detailed in Figure 5, the SX1240 is placed directly in transmit mode. It will then remain in transmit mode until a second TWI register write operation where, if reset to logical '0', the SX1240 returns to sleep mode. An illustration of this operation is shown in the following timing diagram.

Please also note that once in sleep mode, subsequent activity on the DATA pin (without clocking of the CTRL line) will trigger transmission in accordance with Figure 4. Care must hence be taken to avoid inadvertent transmission due to such activity.

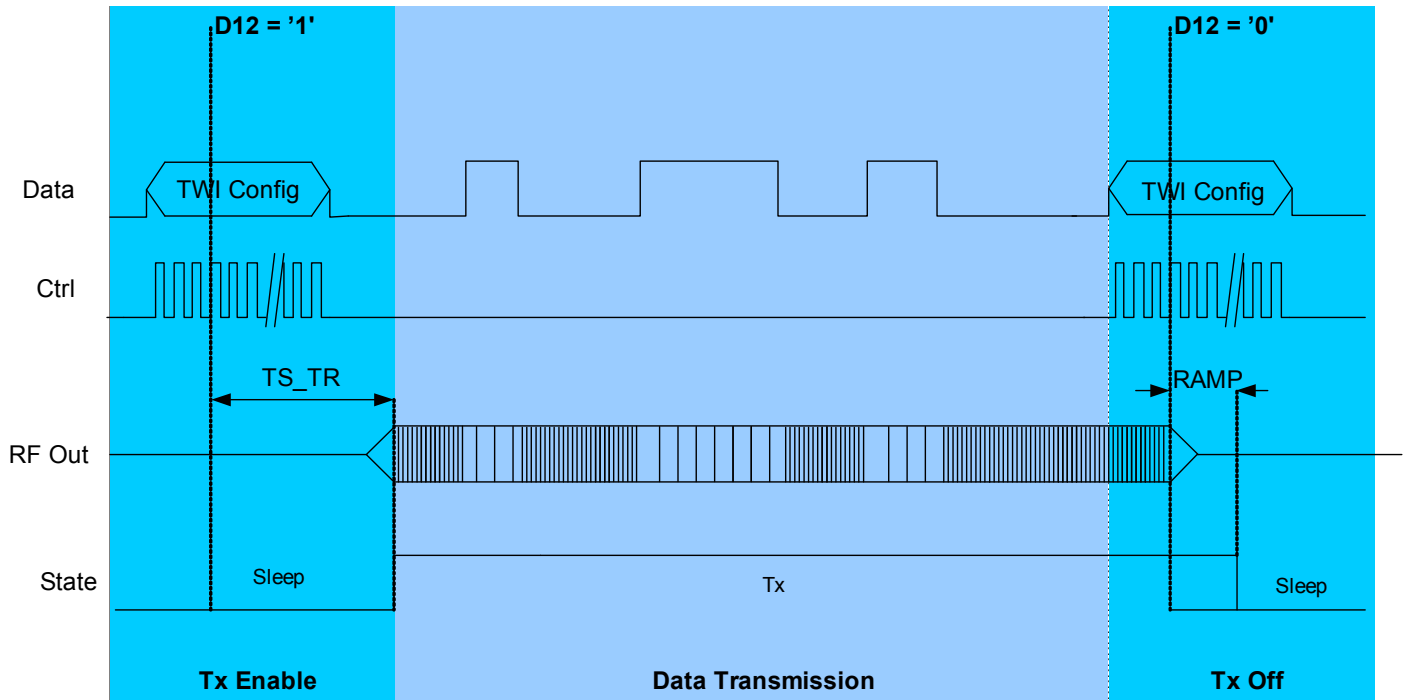

Figure 8. Manual Control of Transmitter Enable via the TWI

## 4. Configuration Register

Table 8 SX1240 TWI Register Description

Bit	Name	Nbits	State	Setting	Default		Notes
					CTRL = '0'	CTRL = '1'	
D12	Tx Mode	1	0 1	Power & Go Forced Transmit	0	0	When set to '1' SX1240 is in continuous Tx until reset to '0'.
D(11:9)	Frequency	3	000 001 010 011 100 101 110 111	418.00 MHz 433.42 MHz 433.92 MHz 864.00 MHz 868.30 MHz 868.65 MHz 868.95 MHz 869.85 MHz	100	010	RF Operating centre frequency
D8	Modulation	1	0 1	FSK OOK	0	1	Modulation format
D(7:5)	Freq. Deviation	3	000 001 010 011 100 101 110 111	10 kHz 12.5 kHz 20 kHz 25 kHz 40 kHz 50 kHz 80 kHz 100 kHz	010	010	FSK Frequency deviation (not used in OOK mode).
D4	RF Power	1	0 1	0 dBm 10 dBm	1	1	Programmed RF output power.
D3	Tx Timer	1	0 1	2 ms 20 ms	0	1	Transmit power-off timer.
D(2:0)	Fine Tuning	3	011 010 001 000 111 110 101 100	fc + 6 * PLL Step fc + 4 * PLL Step fc + 2 * PLL Step fc + 0 * PLL Step fc - 2 * PLL Step fc - 4 * PLL Step fc - 6 * PLL Step fc - 8 * PLL Step	000	000	Fine tuning from programmed centre frequency.
T(42:0)	Test	43	-	-	-	-	Test registers

## 5. Application Information

### 5.1. Crystal Specification

The SX1240 is designed to operate with a low-cost 26 MHz crystal.

*Table 9 SX1240 Quartz Crystal Reference Oscillator Specification*

Symbol	Description	Conditions	Min	Typ	Max	Unit
FXOSC	Crystal Frequency		26	26	26	MHz
LM	Crystal Motional Inductance		-	12.655	-	mH
CM	Crystal Motional Capacitance		-	2.962	-	fF
RS	Crystal Serial Resistance		-	20	100	Ohms
C0	Crystal Shunt Capacitance		-	1.0	7.0	pF
CL	Load Capacitance		-	15	-	pF

### 5.2. Reference Design Schematics

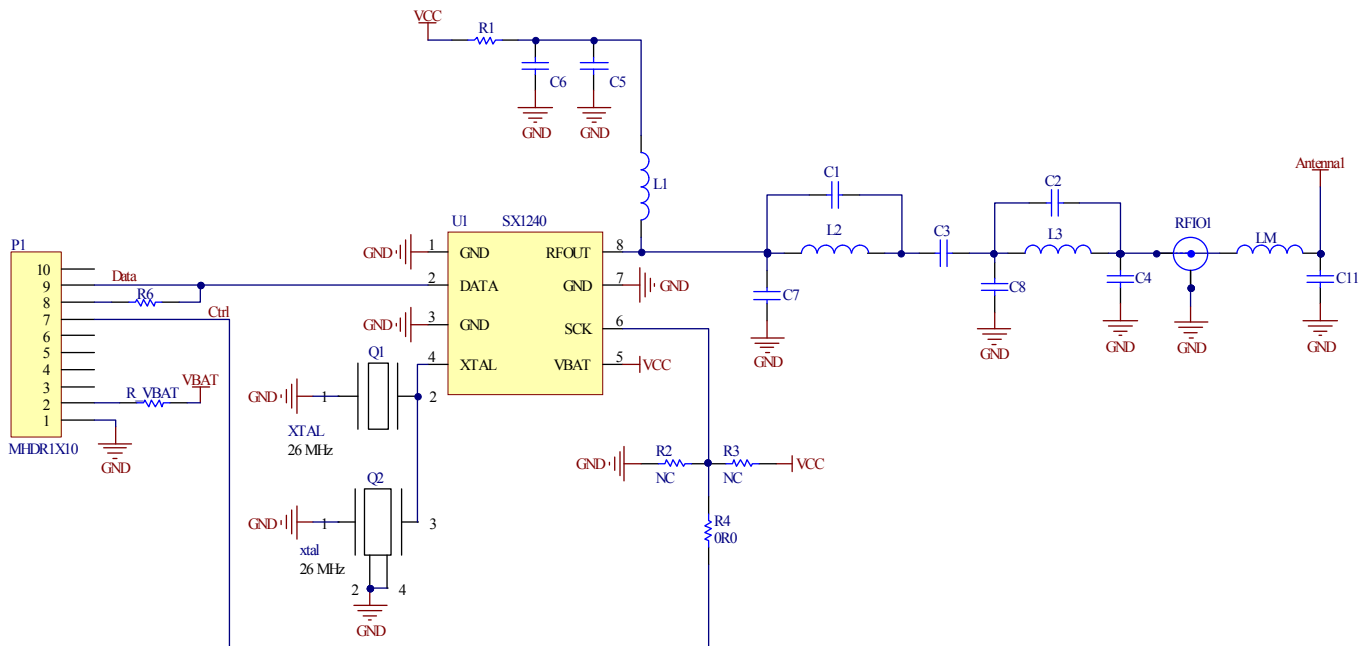

*Figure 9. Application Module Schematics (See BoM for Optional Components)*

### 5.3. Reference Design PCB Layout

With careful RF design practices, the SX1240 can be designed on a single-layer PCB, optimizing the cost of the application. The single layer design below also features a spiral antenna and optional on-board regulation.

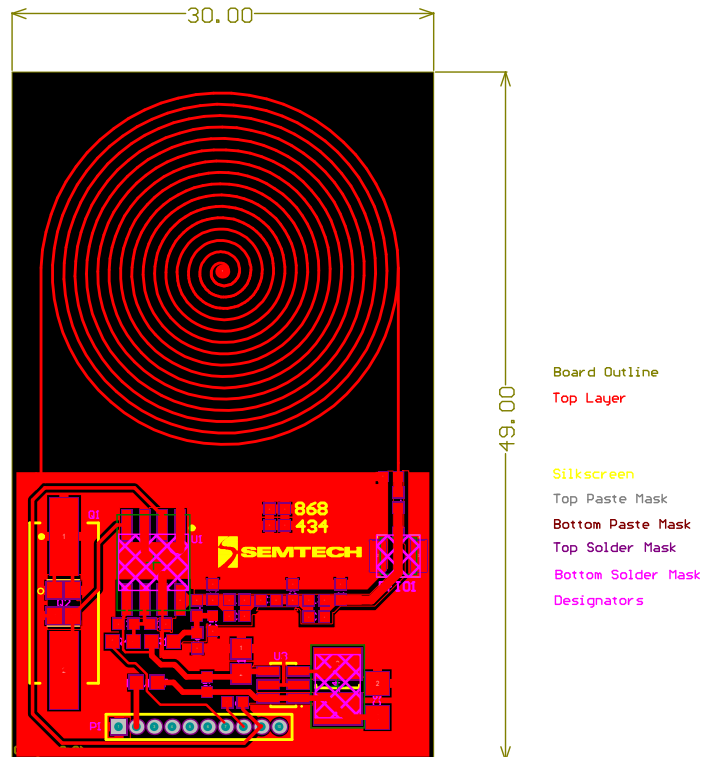

Figure 10. Reference Design PCB Layout

### 5.4. Reference Design BOM

The following tables summarize the module BoM for 434 MHz and 868 MHz band operation.

*Table 10 434 MHz Single Layer Reference Design BoM*

Designator	Part Number	Package	Value	Qty	Description	Manufacturer
U1	SX1240ISRT	SO8	SX1240	1	RF Transmitter IC	Semtech
Q1	-	HC49	26 MHz	1	Crystal 26 MHz CL = 15 pF	-
C1	-	0402	NC	0	Capacitor NPO (+/-5%)	-
C2	-	0402	3.3 pF	1	Capacitor NPO (+/-0.25 pF)	-
C3	-	0402	S/C	0	-	-
C4	-	0402	8.2 pF	1	Capacitor NPO (+/-5%)	-
C5	-	0402	100 pF	1	Capacitor NPO (+/-5%)	-
C6	-	0402	100 nF	1	Capacitor X7R (+/-10%)	-
C7	-	0402	1 pF	1	Capacitor NPO (+/-0.25 pF)	-
C8	-	0402	8.2 pF	1	Capacitor NPO (+/-5%)	-
L1	LQG15	0402	120 nH	1	Multilayer chip inductor	Murata or equivalent
L2	LQG15	0402	22 nH	1	Multilayer chip inductor	Murata or equivalent
L3	LQG15	0402	15 nH	1	Multilayer chip inductor	Murata or equivalent
Q2	-	2.5 x 3.2 mm	26 MHz	-	Optional replacement of Q1	-
C11	-	0402	TBC	-	Antenna Matching Component	-
LM	-	0402	TBC	-	Antenna Matching Component	-
R1	-	0402	0R0	-	Optional PA Supply Isolation	-
R2	-	0402	0R0	-	Optional CTRL 'hi' Connection	-
R3	-	0402	0R0	-	Optional CTRL 'lo' Connection	-
R4	-	0402	0R0	-	Optional CTRL Isolation	-
R VBAT	-	0402	0R0	-	Optional Supply Isolation	-
R6	-	0402	0R0	-	Optional Data Connection to header	-

*Table 11 868 MHz Reference Design BoM*  
**To be Confirmed**



## 6. Packaging Information

### 6.1. Package Outline Drawing

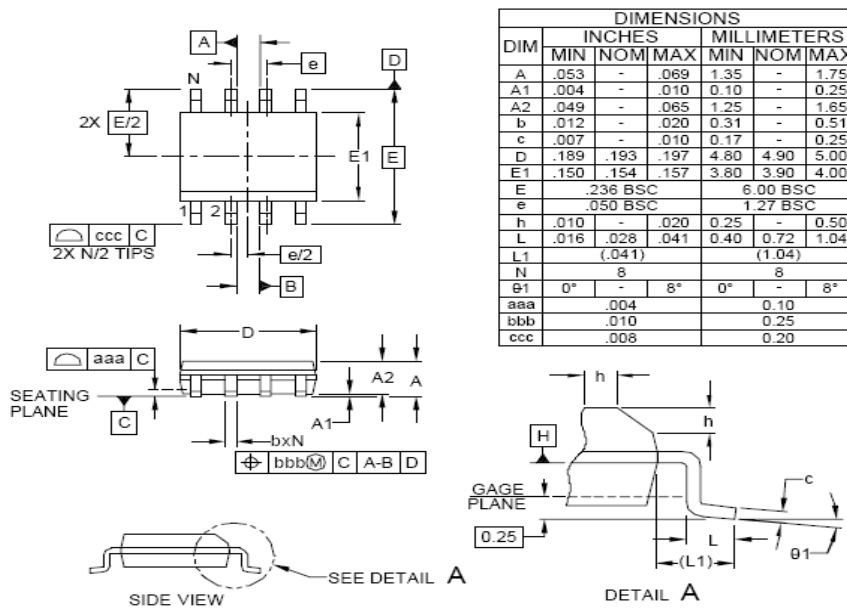

NOTES:

1. CONTROLLING DIMENSIONS ARE IN MILLIMETERS (ANGLES IN DEGREES).
2. DATUMS **-A-** AND **-B-** TO BE DETERMINED AT DATUM PLANE **-H-**.
3. DIMENSIONS "E1" AND "D" DO NOT INCLUDE MOLD FLASH, PROTRUSIONS OR GATE BURRS.
4. REFERENCE JEDEC STD MS-012, VARIATION AA.

Figure 11. Package Outline Drawing

### 6.2. Land Pattern

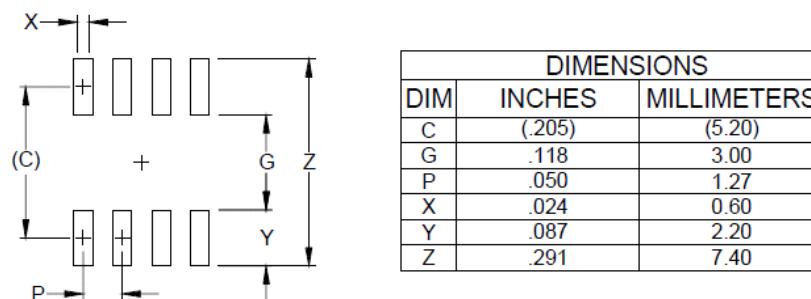

NOTES:

1. THIS LAND PATTERN IS FOR REFERENCE PURPOSES ONLY. CONSULT YOUR MANUFACTURING GROUP TO ENSURE YOUR COMPANY'S MANUFACTURING GUIDELINES ARE MET.
2. REFERENCE IPC-SM-782A, RLP NO. 300A.

Figure 12. Land Pattern

### 6.3. Tape & Reel Specification

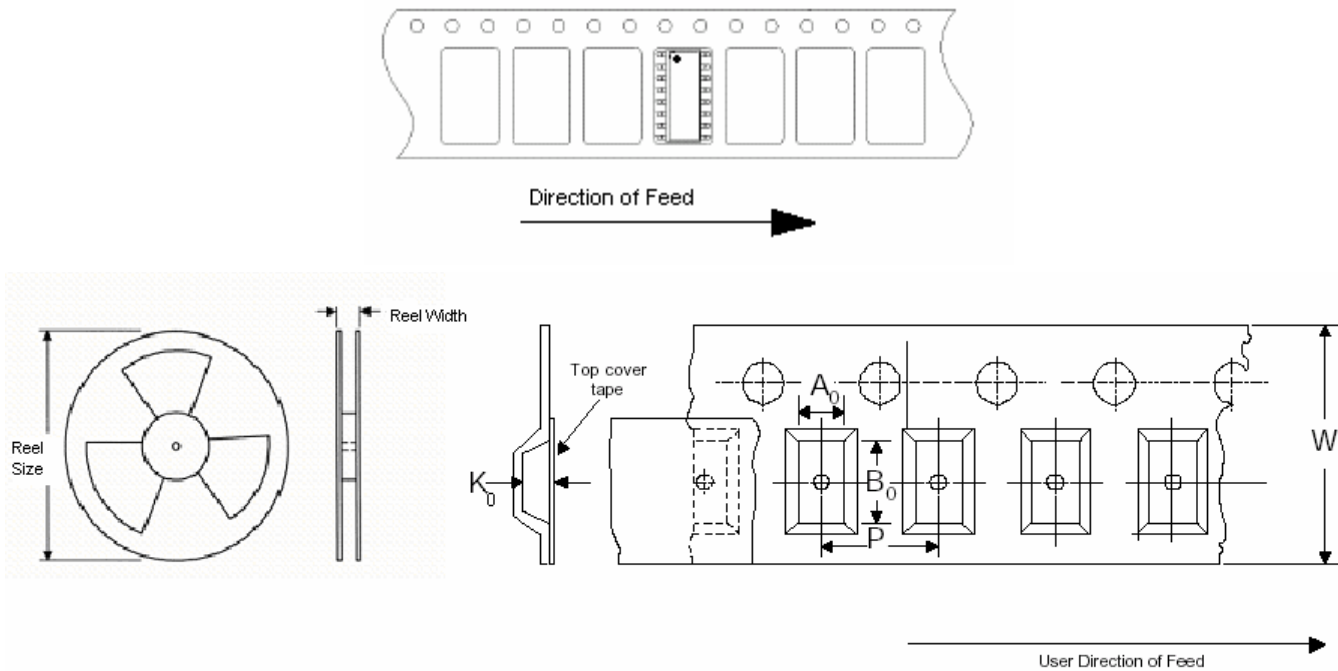

Carrier Tape				Reel					
Tape Width (W)	Pocket Pitch (P)	A <sub>0</sub> / B <sub>0</sub>	K <sub>0</sub>	Reel Size	Reel Width	Min. Trailer Length	Min. Leader Length	QTY per	Unit
12 +/-0.30	8 +/-0.10	6.5 / 5.4 +/-0.30	2.00 +/-0.15	330.2	12.4	400	400	2500	mm

Figure 13. Tape & Reel Specification

Note Single Sprocket Holes

## 7. Revision History

### *Revision History*

Revision	Date	Comment
1	October 2010	First FINAL datasheet version

© Semtech 2010

All rights reserved. Reproduction in whole or in part is prohibited without the prior written consent of the copyright owner. The information presented in this document does not form part of any quotation or contract, is believed to be accurate and reliable and may be changed without notice. No liability will be accepted by the publisher for any consequence of its use. Publication thereof does not convey nor imply any license under patent or other industrial or intellectual property rights. Semtech assumes no responsibility or liability whatsoever for any failure or unexpected operation resulting from misuse, neglect improper installation, repair or improper handling or unusual physical or electrical stress including, but not limited to, exposure to parameters beyond the specified maximum ratings or operation outside the specified range.

SEMTECH PRODUCTS ARE NOT DESIGNED, INTENDED, AUTHORIZED OR WARRANTED TO BE SUITABLE FOR USE IN LIFE-SUPPORT APPLICATIONS, DEVICES OR SYSTEMS OR OTHER CRITICAL APPLICATIONS. INCLUSION OF SEMTECH PRODUCTS IN SUCH APPLICATIONS IS UNDERSTOOD TO BE UNDERTAKEN SOLELY AT THE CUSTOMER'S OWN RISK. Should a customer purchase or use Semtech products for any such unauthorized application, the customer shall indemnify and hold Semtech and its officers, employees, subsidiaries, affiliates, and distributors harmless against all claims, costs damages and attorney fees which could arise.

## Contact information

### Semtech Corporation Advanced Communications & Sensing Products

E-mail: [sales@semtech.com](mailto:sales@semtech.com) [acsupport@semtech.com](mailto:acsupport@semtech.com) Internet: <http://www.semtech.com>

**USA**

200 Flynn Road, Camarillo, CA 93012-8790.  
Tel: +1 805 498 2111 Fax: +1 805 498 3804

**FAR EAST**

12F, No. 89 Sec. 5, Nanking E. Road, Taipei, 105, TWN, R.O.C.  
Tel: +886 2 2748 3380 Fax: +886 2 2748 3390

**EUROPE**

Semtech Ltd., Units 2 & 3, Park Court, Premier Way, Abbey Park Industrial Estate, Romsey, Hampshire, SO51 9DN.  
Tel: +44 (0)1794 527 600 Fax: +44 (0)1794 527 601

Компания «Океан Электроники» предлагает заключение долгосрочных отношений при поставках импортных электронных компонентов на взаимовыгодных условиях!

Наши преимущества:

- Поставка оригинальных импортных электронных компонентов напрямую с производств Америки, Европы и Азии, а так же с крупнейших складов мира;
- Широкая линейка поставок активных и пассивных импортных электронных компонентов (более 30 млн. наименований);
- Поставка сложных, дефицитных, либо снятых с производства позиций;
- Оперативные сроки поставки под заказ (от 5 рабочих дней);
- Экспресс доставка в любую точку России;
- Помощь Конструкторского Отдела и консультации квалифицированных инженеров;
- Техническая поддержка проекта, помощь в подборе аналогов, поставка прототипов;
- Поставка электронных компонентов под контролем ВП;
- Система менеджмента качества сертифицирована по Международному стандарту ISO 9001;
- При необходимости вся продукция военного и аэрокосмического назначения проходит испытания и сертификацию в лаборатории (по согласованию с заказчиком);
- Поставка специализированных компонентов военного и аэрокосмического уровня качества (Xilinx, Altera, Analog Devices, Intersil, Interpoint, Microsemi, Actel, Aeroflex, Peregrine, VPT, Syfer, Eurofarad, Texas Instruments, MS Kennedy, Miteq, Cobham, E2V, MA-COM, Hittite, Mini-Circuits, General Dynamics и др.);

Компания «Океан Электроники» является официальным дистрибьютором и эксклюзивным представителем в России одного из крупнейших производителей разъемов военного и аэрокосмического назначения «JONHON», а так же официальным дистрибьютором и эксклюзивным представителем в России производителя высокотехнологичных и надежных решений для передачи СВЧ сигналов «FORSTAR».



## JONHON

«JONHON» (основан в 1970 г.)

Разъемы специального, военного и аэрокосмического назначения:

(Применяются в военной, авиационной, аэрокосмической, морской, железнодорожной, горно- и нефтедобывающей отраслях промышленности)

«FORSTAR» (основан в 1998 г.)

ВЧ соединители, коаксиальные кабели,  
кабельные сборки и микроволновые компоненты:

(Применяются в телекоммуникациях гражданского и специального назначения, в средствах связи, РЛС, а так же военной, авиационной и аэрокосмической отраслях промышленности).



Телефон: 8 (812) 309-75-97 (многоканальный)

Факс: 8 (812) 320-03-32

Электронная почта: [ocean@oceanchips.ru](mailto:ocean@oceanchips.ru)

Web: <http://oceanchips.ru/>

Адрес: 198099, г. Санкт-Петербург, ул. Калинина, д. 2, корп. 4, лит. А