

GENERAL DESCRIPTION

The DS620 digital thermometer and thermostat provides low-voltage ($1.7\text{V} \leq V_{\text{DD}} \leq 3.5\text{V}$) temperature measurements with $\pm 0.5^{\circ}\text{C}$ accuracy from 0°C to $+70^{\circ}\text{C}$ and an operating temperature range of -55°C to $+125^{\circ}\text{C}$. The DS620 communicates over a 2-wire digital interface. For distributed-sensing applications, it is multidroppable with three address pins that allow up to eight DS620s to operate on a single bus.

The DS620 has thermostat functionality with user-defined thresholds stored in EEPROM registers, and it can be configured for standalone thermostat operation. The programmable output (PO) pin serves as the thermostat output, and this pin can also be configured to function as an active-low control for peripheral devices.

APPLICATIONS

- Portable Applications
- Low-Voltage Temperature-Sensitive Applications
- Computers/Servers
- Test Equipment
- Medical Instruments
- Industrial Applications

FEATURES

- Low-Voltage Operation: 1.7V to 3.5V
- $\pm 0.5^{\circ}\text{C}$ Accuracy from 0°C to $+70^{\circ}\text{C}$
- Operating Temperature Range: -55°C to $+125^{\circ}\text{C}$ (-67°F to $+257^{\circ}\text{F}$)
- Temperature Measurements Require No External Components
- Resolution is User-Selectable to 10-, 11-, 12-, or 13-Bits (0.5°C , 0.25°C , 0.125°C , and 0.0625°C Lsb Weight, Respectively)
- Multidroppable
- Fast (200ms max) Temperature-to-Digital Conversion Time
- Thermostatic Settings are User-Definable and Nonvolatile
- Standalone Thermostat Capability
- Data is Read/Written Through a 2-Wire Serial Interface
- Package: 8-Pin μSOP

ORDERING INFORMATION

PART	TEMP RANGE	PIN-PACKAGE
DS620U	-55°C to $+125^{\circ}\text{C}$	8 μSOP , Exposed Pad
DS620U/T&R	-55°C to $+125^{\circ}\text{C}$	8 μSOP Exposed Pad Tape-and-Reel

TYPICAL OPERATING CIRCUIT

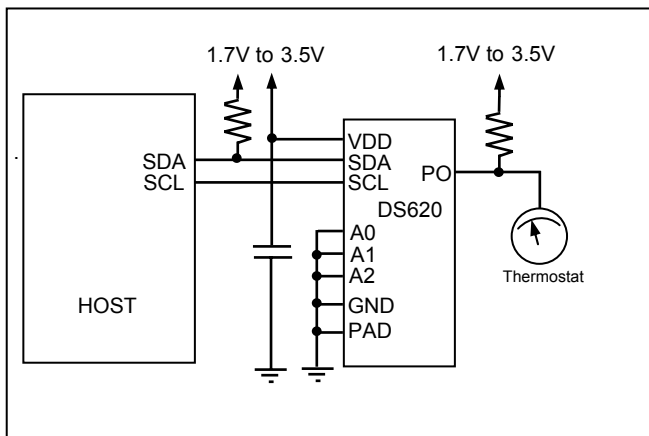

PIN CONFIGURATION

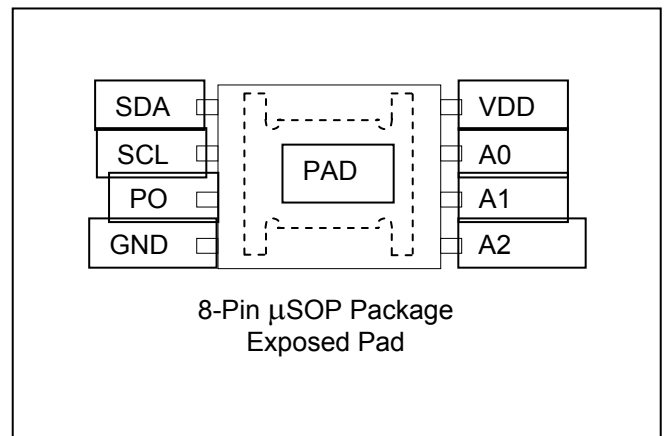

PIN DESCRIPTION

PIN	NAME	FUNCTION
1	SDA	Data Input/Output Pin for serial communication. Open drain. (No diode connection to V_{DD}).
2	SCL	Clock Input Pin for 2-wire serial communication.
3	PO	Programmable Output Pin. Open drain. (No diode connection to V_{DD}).
4	GND	Ground Pin.
5	A2	Address Input Pin.
6	A1	Address Input Pin. Also serves as an input to trigger one-shot conversions during standalone use.
7	A0	Address Input Pin.
8	V_{DD}	Supply Voltage Pin. +1.7V to +3.5V power supply pin.
	PAD	PAD. Connect to GND or float. DO NOT CONNECT TO SUPPLY. The exposed pad is the best way to conduct temperature into the package. Connecting PAD to a ground plane can assist in properly measuring the temperature of the circuit board.

Figure 1. Block Diagram

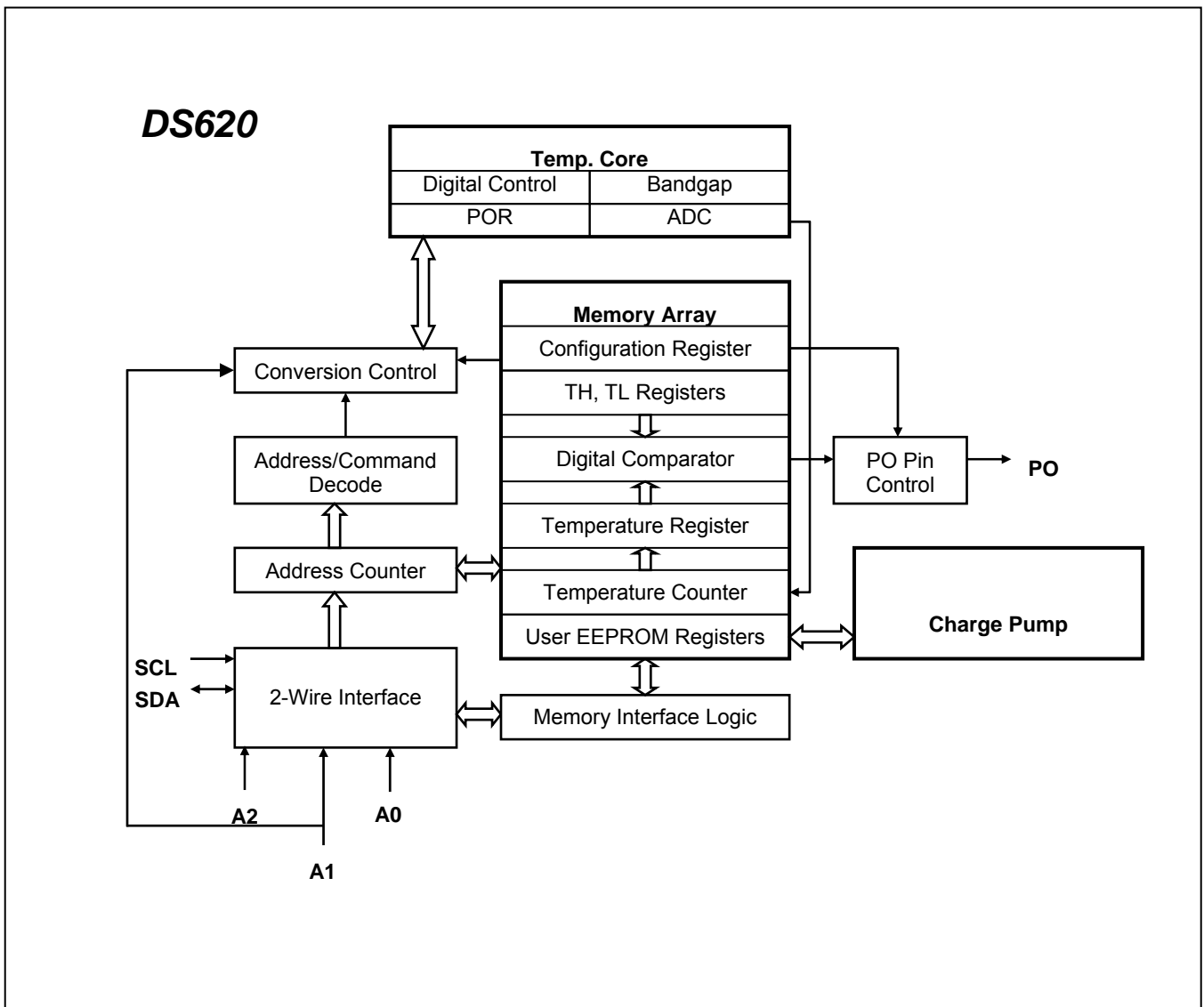

ABSOLUTE MAXIMUM RATINGS

Voltage Range on Any Pin, Relative to Ground
 Operating Temperature Range
 Storage Temperature Range
 Soldering Temperature
 ESD rating on all pins

-0.5V to +4.5V
 -55°C to +125°C
 -55°C to +125°C
 See IPC/JEDEC J-STD-020A Specification
 4KV HBM

Stresses beyond those listed under "Absolute Maximum Ratings" may cause permanent damage to the device. These are stress ratings only, and functional operation of the device at these or any other conditions beyond those indicated in the operational sections of the specifications is not implied. Exposure to the absolute maximum rating conditions for extended periods may affect device.

RECOMMENDED DC OPERATING CONDITIONS

($3.5V \geq V_{DD} \geq 1.7V$, $T_A = -55^\circ\text{C}$ to $+125^\circ\text{C}$.)

PARAMETER	SYMBOL	CONDITIONS	MIN	TYP	MAX	UNITS
Voltage Range on Any Pin, Relative to Ground	V_{DD}	(Note 1)	1.7		3.5	V
Supply Voltage for EEPROM Writes	V_{DD}	(Note 1)	2.0		3.5	V

DC ELECTRICAL CHARACTERISTICS

($3.5V \geq V_{DD} \geq 1.7V$, $T_A = -55^\circ\text{C}$ to $+125^\circ\text{C}$.)

PARAMETER	SYMBOL	CONDITIONS	MIN	TYP	MAX	UNITS
Thermometer Error	T_{ERR}	0°C to +70°C			±0.5	°C
		-55°C to +125°C			±2	
Input Logic High	V_{IH}	(Note 1)	0.7 x V_{DD}		$V_{DD} + 0.5$	V
Input Logic Low	V_{IL}	(Note 1)	-0.5		0.3 x V_{DD}	V
SDA Output Logic Low Voltage	V_{OL1}	3mA sink current (Note 1)	0		0.4	V
	V_{OL2}	6mA sink current (Note 1)	0		0.6	
PO Saturation Voltage	V_{OL}	4mA sink current (Note 1)	0		0.4	V
Input Current for each I/O pin		$0.4 < V_{IO} < 0.9 \times V_{DD}$	-10		+10	µA
I/O Capacitance	$C_{I/O}$				10	pF
Standby Current	I_{STBY}	0°C to +70°C (Note 2)			2	µA
Active Supply Current	I_{DD}	Temperature conversion, -55°C to +85°C (Note 3)			800	µA
		Temperature conversion, +85°C to +125°C (Note 3)			900	
		E ² write (Note 3)			500	µA
Temperature Conversion Time	T_{TC}	10 bit			25	ms
		11 bit			50	
		12 bit			100	
		13 bit			200	

Note 1: All voltages are referenced to GND.

Note 2: Specified with SDA = V_{DD} ; A₀, A₁, A₂ = 0V or V_{DD} .

Note 3: Specified with A₀, A₁, A₂ = 0V or V_{DD} .

AC ELECTRICAL CHARACTERISTICS**EEPROM AC Electrical Characteristics**

PARAMETER	SYMBOL	CONDITIONS	MIN	TYP	MAX	UNITS
EEPROM Write Cycle Time	T_{WR}	-40°C to +85°C			10	ms
EEPROM Writes	N_{EEWR}	-40°C ≤ T_A ≤ +85°C (Note 1)	10k	20k		writes
		T_A = +25°C (Note 1)	40k	80k		
EEPROM Data Retention	t_{EEDR}	-40°C to +125°C (Note 2)	10			years

2-Wire AC Electrical Characteristics

PARAMETER	SYMBOL	CONDITIONS	MIN	TYP	MAX	UNITS
SCL Frequency	f_{SCL}		0		400	KHz
Bus Free Time Between a STOP and START Condition	t_{BUF}		1.3			μs
START and Repeat START Hold Time from Falling SCL	$t_{HD:STA}$	(Note 3, 4)	0.6			μs
Low Period of SCL	t_{LOW}	(Note 3)	1.3			μs
High Period of SCL	t_{HIGH}	(Note 3)	0.6			μs
Repeated START Condition Setup Time to Rising SCL	$t_{SU:STA}$	(Note 3)	0.6			μs
Data-Out Hold Time from Falling SCL	$t_{HD:DAT}$	(Note 3)	0		0.9	μs
Data-In Setup Time to Rising SCL	$t_{SU:DAT}$	(Note 3)	100			ns
Rise Time of SDA and SCL	t_R	(Note 3, 5)	20 + 0.1x C_B		1000	ns
Fall Time of SDA and SCL	t_F	(Note 3, 5)	20 + 0.1x C_B		300	ns
STOP Setup Time to Rising SCL	$T_{SU:STO}$		0.6			μs
Capacitive Load for Each BUS Line	C_B				400	pF
Input Capacitance	C_I			10		pF
Spike Pulse Width that can be Suppressed by Input Filter			0		50	ns

Note 1: V_{DD} must be 2.0V to 3.5V.

Note 2: Write done at 25°C.

Note 3: All values referenced to 0.9 V_{DD} and 0.1 V_{DD} .

Note 4: After this period the first clock pulse is generated.

Note 5: For example, if C_B = 300pF, then $t_R(\text{MIN})$ = $t_F(\text{MIN})$ = 50ns.

Figure 2. Timing Diagram

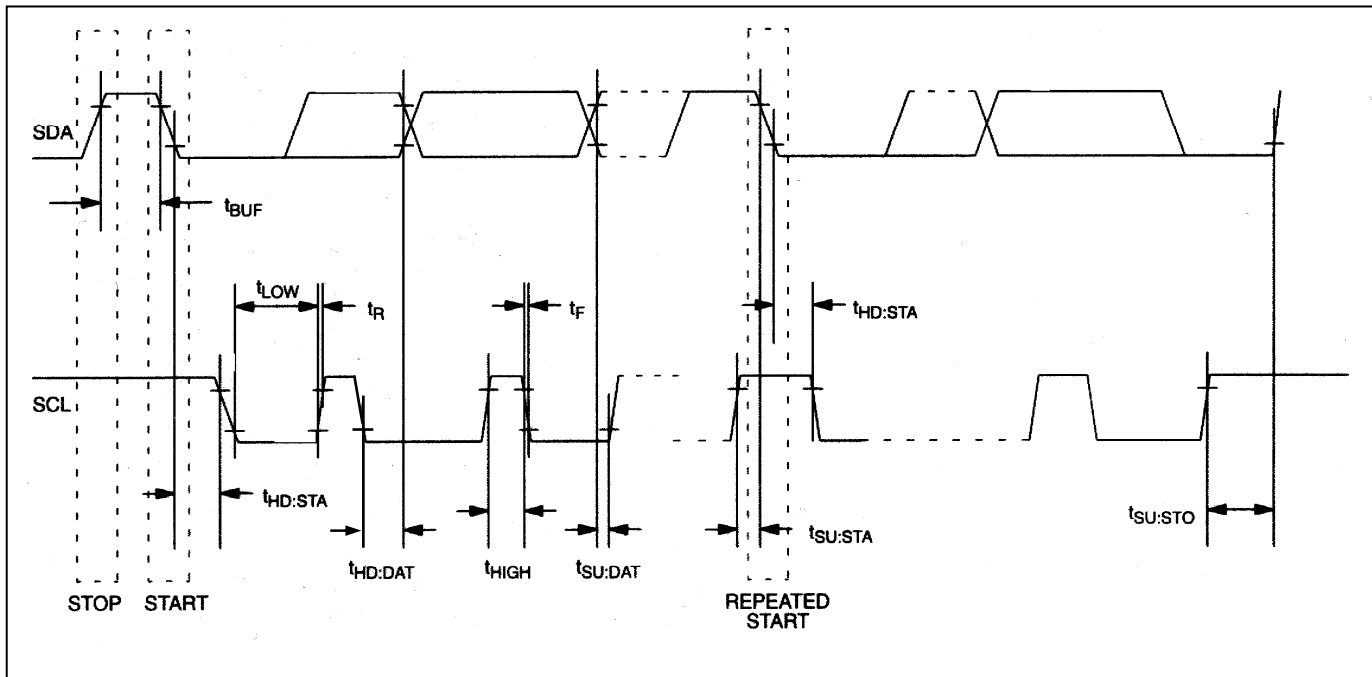

Table 1. Register Summary

Parameter	Information
T_H and T_L Registers Size: 2-Bytes Note that the 3 LSBs are always “don’t cares” for writes (i.e., they are not saved) and always read out as 0s.	EEPROM Factory State: $T_H = 15^\circ\text{C}$ (0000 0111 1000 0000) [0780h] $T_L = 10^\circ\text{C}$ (0000 0101 0000 0000) [0500h]
Configuration Register Size: 2-Bytes	SRAM and EEPROM. See Figure 4 and Table 5 for detailed information and power-up/factory state.
Temperature Register Size: 2-Bytes	SRAM Power-Up State: -60°C (1110 0010 0000 0000) [E200h]

TEMPERATURE MEASUREMENT

The DS620 measures temperature using a bandgap-based temperature sensor. A delta-sigma, analog-to-digital converter (ADC) converts measured temperature to a 10-, 11-, 12-, or 13-bit (user-selectable) digital value that is calibrated in $^\circ\text{C}$; for $^\circ\text{F}$ applications, a lookup table or conversion routine must be used. Throughout this data sheet, the term “conversion” is used to refer to the entire temperature measurement and ADC sequence.

The DS620 can be configured to power up either automatically converting temperature or in a low-power standby state. The preferred power-up mode can be set using the AUTOC bit in the configuration register as explained in the *Configuration Register* section of this data sheet.

The DS620 can be programmed to perform continuous consecutive conversions (continuous conversion mode) or to perform single conversions on command (one-shot mode). The conversion mode is programmed through the 1SHOT bit in the configuration register as explained in the *Configuration Register* section of this data sheet. In continuous conversion mode, conversions are performed after a Start Convert command is issued (or upon power-up if the AUTOC bit in the configuration register is set to 1) until a Stop Convert command is issued, at which time the device goes into a low-power standby state. Continuous conversions can be restarted at any time using the Start Convert command. In one-shot mode, the DS620 performs a single temperature conversion either at power-up (if AUTOC = 1) or when a Start Convert command is issued (if AUTOC = 0). When the conversion is complete,

the device enters a low-power standby state and remains in that state until a temperature conversion is again initiated by a Start Convert command.

The R0 and R1 bits in the configuration register allow the user to set the conversion resolution to be 10, 11, 12, or 13 bits (0.5°C, 0.25°C, 0.125°C, and 0.0625°C Lsb weight, respectively) as shown in Table 6. The default resolution at power-up is 13-bits. Note that the conversion time doubles for each additional bit of resolution.

After each conversion, the digital temperature is stored as a 16-bit two's complement number in the 2-byte temperature register as shown in Figure 3. The temperature register is located in address spaces AAh (MSB) and ABh (LSB) of the DS620 memory. The sign bit (S) indicates if the temperature is positive (S = 0) or negative (S = 1). Bits 2, 1, and 0 of the temperature register are hardwired to 0. When the device is configured for 13-bit resolution, the 13 MSBs (bits 15 through 3) of the temperature register will contain temperature data. For 12-bit resolution, the 12 MSBs (bits 15 through 4) of the temperature register will contain data, and bit 3 will be 0. Likewise, for 11-bit resolution, the 11 MSBs (bits 15 through 5) will contain data, and for 10-bit the 10 MSBs (bits 15 through 6) will contain data, and all unused LSBs will contain 0s. Table 2 gives examples of 13-bit resolution output data and the corresponding temperatures.

Figure 3. Temperature, T_H, And T_L Register Format

	bit 15	bit 14	bit 13	Bit 12	bit 11	bit 10	bit 9	bit 8
MS Byte	S	2 ⁷	2 ⁶	2 ⁵	2 ⁴	2 ³	2 ²	2 ¹
	bit 7	bit 6	bit 5	Bit 4	bit 3	bit 2	bit 1	bit 0
LS Byte	2 ⁰	2 ⁻¹	2 ⁻²	2 ⁻³	2 ⁻⁴	0	0	0

Table 2. 13-Bit Resolution Temperature/Data Relationship

Temperature (°C)	Digital Output (binary)	Digital Output (hex)
+125	0011 1110 1000 0000	3E80h
+25.0625	0000 1100 1000 1000	0C88h
+10.125	0000 0101 0001 0000	0510h
+0.5	0000 0000 0100 0000	0040h
0	0000 0000 0000 0000	0000h
-0.5	1111 1111 1100 0000	FFC0h
-10.125	1111 1010 1111 0000	FAF0h
-25.0625	1111 0011 0111 1000	F378h
-55	1110 0100 1000 0000	E480h

WRITING TO THE TEMPERATURE REGISTER

The user is given access to write to the DS620 temperature register. This feature can be used for system test and debugging by allowing the user to force the temperature reading above or below fault thresholds without having to heat or cool the device.

If data is written to the temperature register while conversions are in progress, the result of the next completed conversion will overwrite any data that was written to the temperature register. Additionally, no update of the flag bits in the configuration register, nor an update of the PO pin occur as a result of the temperature being written if a conversion is taking place. To avoid this from happening, conversions should first be stopped before writing to the temperature register. When writing to the temperature register, both the MSB and the LSB should be written. An update of the flag bits and PO pin will only occur after the LSB has been written. See *Writing to the DS620* for more information.

THERMOSTAT OPERATION

The PO pin on the DS620 operates as the thermostat output when it is configured as PO_{HIGH} or PO_{LOW} through the P01 and P02 bits of the configuration register. In both of these configurations, PO is updated after every temperature conversion or write to the temperature register, and remains at the updated value until the next conversion or write completes. PO_{HIGH} and PO_{LOW} are active-low and are activated and deactivated based on user-defined upper and lower trip-points. PO_{HIGH} is activated when the measured temperature meets or exceeds the value stored in the upper trip-point register (T_H), and stays active until the temperature meets or falls below the value stored in the lower trip-point register (T_L) (see Figure 4a). This allows the user to program any amount of hysteresis into the output response. Similarly, PO_{LOW} is activated when the measured temperature meets or goes below the value stored in the low trip-point register (T_L), and stays active until the temperature meets or exceeds the value stored in the upper trip-point register (T_H) (see Figure 4b). The T_H register is located in address spaces A0h (MSB) and A1h (LSB) and the T_L register is located in address spaces A2h (MSB) and A3h (LSB) of the DS620 memory.

The T_H and T_L registers (see Table 1) contain centigrade temperature values in two's complement format and are stored in EEPROM; therefore, they are nonvolatile (NV) and can be programmed prior to installation of the DS620 for use in standalone applications. All bits in the T_H and T_L registers are used in the comparison to the temperature value in the temperature register for the thermostat operation, regardless of the number of bits used for the temperature conversions as decided by the R0 and R1 bits in the configuration register. Therefore, to ensure proper thermostat operation, any bits not used for the temperature measurement should be set to 0 in the T_H and T_L registers. For example, for 11-bit temperature conversions, bits 3 and 4 in the T_H and T_L register should be set to 0 prior to comparison to the measured temperature. (Bits 0 to 2 are automatically set to 0).

Another thermostat feature is the temperature high and low flags (THF and TLF) in the configuration register. These bits provide a record of whether the temperature has ever been equal to or greater than T_H or equal to or less than T_L at anytime since power up or since the bits were last cleared. If the temperature ever meets or exceeds the T_H register value, the THF bit in the configuration register is set to 1, and if the temperature ever meets or falls below the T_L value, the TLF bit in the configuration register is set to 1. Once THF or TLF has been set, it remains set until the power is cycled or it is overwritten with a 0 by the user.

Figure 4. Thermostat Operation

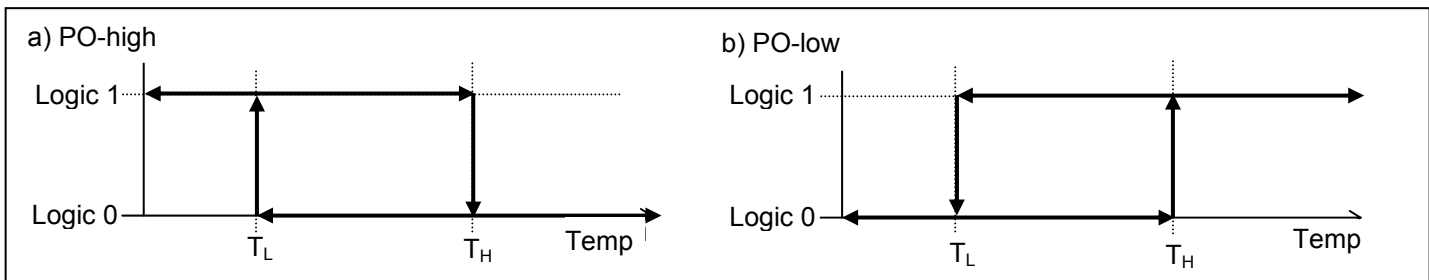

STANDALONE THERMOSTAT OPERATION

The DS620 can function as a standalone thermostat, i.e., it can provide thermostat functionality without requiring communication with a microcontroller. For standalone thermostat operation, the T_H , T_L , and configuration registers must be programmed to the desired values prior to installation. For standalone operation, the AUTOC bit in the configuration register must be set to 1 so that measurements begins automatically at power up. This also configures the A1 pin as an input pin that can trigger a conversion. In addition, PO must be configured as PO_{HIGH} or PO_{LOW}. The 1SHOT bit in the configuration register is used to enable the DS620 to perform continuous conversions at power up (1SHOT = 0) or a single conversion (one-shot) at power up or upon request (1SHOT = 1). In one-shot mode, one conversion is performed at power-up and then the device enters a low-power standby state until A1 is toggled high. The A1 pin must be toggled low and back high again to start another conversion.

PO PIN

The PO pin is a user-programmable open-drain output, which is configured through the PO1 and PO2 bits in the configuration register. PO can operate as a thermostat output (PO_{HIGH} or PO_{LOW}), or it can be forced low for control of peripheral devices. When PO is configured as PO_{HIGH} or PO_{LOW}, this pin operates as described in the *Thermostat Operation* section. This pin can be reconfigured at anytime to switch between functions. Table 3 defines the various configuration options for this pin.

Table 3. PO Configuration

Function	PO2	PO1
Thermostat Output (PO-high)	1	1
Thermostat Output (PO-low)	1	0
Force PO Low	0	X

EEPROM REGISTERS AND MEMORY MAP

The DS620 has a 14-byte linear address space with registers for temperature, thermostat thresholds, and control as well as four bytes of user EEPROM for general use. All address space is shadowed by RAM. The DS620 Memory Map is shown in Table 4.

See the *Writing to the DS620* and the *Reading from the DS620* sections for details in writing to and reading from the DS620 EEPROM registers and memory map.

Table 4. Memory Map

Address (hex)	Description
A0	TH MSB
A1	TH LSB
A2	TL MSB
A3	TL LSB
A4	User
A5	User
A6	User
A7	User
A8	Undefined
A9	Undefined
AA	Temperature MSB
AB	Temperature LSB
AC	Configuration MSB
AD	Configuration LSB

CONFIGURATION REGISTER

The configuration register allows the user to program various DS620 options such as conversion resolution, operating mode, and thermostat capability. It also provides information to the user about conversion status, EEPROM activity, device address, and thermostat activity. The configuration register is arranged as shown in Figure 5 and detailed descriptions of each bit are provided in Table 5. It is located in address spaces ACh (MSB) and ADh (LSB) in the DS620 memory. Note that the R0, R1, AUTOC, 1SHOT, and PO1 bits are stored in EEPROM so they can be programmed prior to installation if desired. All other configuration bits are SRAM and power up in the state shown in Table 5.

Figure 5. Configuration Register

Address ACh							
MS Byte	bit 15	bit 14	bit 13	bit 12	bit 11	bit 10	bit 8
	DONE	NVB	THF	TLF	R1*	R0*	1SHOT*
Address ADh							
LS Byte	bit 7	bit 6	bit 5	bit 4	bit 3	bit 2	bit 0
	PO2	PO1*	A2	A1	A0	M*	M*

* Stored in EEPROM

Table 5. Configuration Register Bit Descriptions

Bit Name	User Access	Functional Description
DONE	Read Only	At power-up, DONE = 1. (Unless AUTOC = 1) DONE = 0—Temperature conversion is in progress. DONE = 1—Temperature conversion is complete.
NVB	Read Only	At power-up, NVB = 0 NVB = 1—Write to an E ² memory cell is in progress NVB = 0—Nonvolatile memory is not busy.
THF	Read/Write	At power-up, THF = 0 THF = 1—The measured temperature has reached or exceeded the value stored in the T _H register at anytime since power-up or since the bit was last cleared. THF remains a 1 until the power is cycled or it is overwritten with a 0 by the user.
TLF	Read/Write	At power-up, TLF = 0 TLF = 1—The measured temperature has met or fallen below the value stored in the T _L register at anytime since power-up or since the bit was last cleared. TLF remains a 1 until the power is cycled or it is overwritten with a 0 by the user.
R1*	Read/Write	Used to set conversion resolution (see Table 6). Factory state = 1
R0*	Read/Write	Used to set conversion resolution (see Table 6). Factory state = 1
AUTOC*	Read/Write	Determines whether the DS620 powers up idle or converting. Factory state = 0 AUTOC = 1—DS620 powers-up converting temperature. AUTOC = 0—DS620 powers-up idle.
1SHOT*	Read/Write	Configures temperature conversion mode. Factory state = 0 1SHOT = 1: One-shot mode <ul style="list-style-type: none"> ▪ For AUTOC = 0, the device powers up idle. The Start Convert command causes a single temperature conversion and then the device returns to a low-power standby state. ▪ If AUTOC = 1, the A1 pin is reconfigured as a conversion trigger for standalone operation and the device powers up and performs 1 conversion. Single conversions can be initiated using the Start Convert command or by toggling A1 high. 1SHOT = 0: Continuous conversion mode <ul style="list-style-type: none"> ▪ For AUTOC = 0, the Start Convert command initiates continuous conversions. ▪ For AUTOC = 1, the device powers up performing continuous conversions. Note: Changing the 1SHOT bit to 1 while continuous conversions are in progress does not stop the conversions. A Stop Convert command must first be issued after which one-shot

		conversions can be performed. See <i>Writing the 1SHOT Bit Command Sequence</i> section for writing more information on writing the 1SHOT bit.
PO2	Read/Write	At power-up, PO2 = 1. PO2 = 0 forces the PO pin low (see Table 3) PO2 = 1 configures PO as the thermostat output (PO _{HIGH} or PO _{LOW} , as determined by PO1).
PO1*	Read/Write	When PO2 = 1, PO1 configures the PO pin as either PO _{HIGH} or PO _{LOW} (see Table 3) When PO2 = 0, PO1 is a “don’t care”. Factory state = 0
A2	Read Only	Shows address bit A ₂ , as determined by pin A2.
A1	Read Only	Shows address bit A ₁ , as determined by pin A1.
A0	Read Only	Shows address bit A ₀ , as determined by pin A0.
M*	Read/Write	User memory for general-purpose data storage.

Stored in EEPROM

Table 6. Resolution Configuration

R1	R0	Resolution	LSb Weight (°C)	Max Conversion Time (ms)
0	0	10-bit	0.5	25
0	1	11-bit	0.25	50
1	0	12-bit	0.125	100
1	1	13-bit	0.0625	200

2-WIRE SERIAL DATA BUS

The DS620 communicates over a standard bidirectional 2-wire serial data bus that consists of a serial clock (SCL) signal and serial data (SDA) signal. The DS620 interfaces to the bus through the SCL input pin and open-drain SDA I/O pin. All communication is MSb first.

The following terminology is used to describe 2-wire communication:

Master Device: Microprocessor/microcontroller that controls the slave devices on the bus. The master device generates the SCL signal and START and STOP conditions.

Slave: All devices on the bus other than the master. The DS620 always functions as a slave.

Bus Idle or Not Busy: Both SDA and SCL remain high. SDA is held high by a pullup resistor when the bus is idle, and SCL must either be forced high by the master (if the SCL output is push-pull) or pulled high by a pullup resistor (if the SCL output is open-drain).

Transmitter: A device (master or slave) that is sending data on the bus.

Receiver: A device (master or slave) that is receiving data from the bus.

START Condition: Signal generated by the master to indicate the beginning of a data transfer on the bus. The master generates a START condition by pulling SDA from high to low while SCL is high (see Figure 6). A “repeated” START is sometimes used at the end of a data transfer (instead of a STOP) to indicate that the master will perform another operation.

STOP Condition: Signal generated by the master to indicate the end of a data transfer on the bus. The master generates a STOP condition by transitioning SDA from low to high while SCL is high (see Figure 6). After the STOP is issued, the master releases the bus to its idle state.

Acknowledge (ACK): When a device (either master or slave) is acting as a receiver, it must generate an acknowledge (ACK) on the SDA line after receiving every byte of data. The receiving device performs an ACK by pulling the SDA line low for an entire SCL period (see Figure 6). During the ACK clock cycle, the transmitting device must release SDA. A variation on the ACK signal is the “not acknowledge” (NACK). When the master device

is acting as a receiver, it uses a NACK instead of an ACK after the last data byte to indicate that it is finished receiving data. The master indicates a NACK by leaving the SDA line high during the ACK clock cycle.

Slave Address: Every slave device on the bus has a unique 7-bit address that allows the master to access that device. The DS620's 7-bit bus address is 1 0 0 1 A₂ A₁ A₀, where A₂, A₁, and A₀ are user-selectable via the corresponding input pins. The three address pins allow up to eight DS620s to be multidropped on the same bus.

Control Byte: The control byte is transmitted by the master and consists of the 7-bit slave address plus a read/write (R/W) bit (see Figure 7). If the master is going to read data from the slave device then R/W = 1, and if the master is going to write data to the slave device then R/W = 0.

Address Byte: The address byte is used by the master to tell the DS620 which address location in the memory map in Table 4 is going to be accessed during communication or which command should be performed. See *Command Set* section.

Figure 6. START, STOP, AND ACK SIGNALS

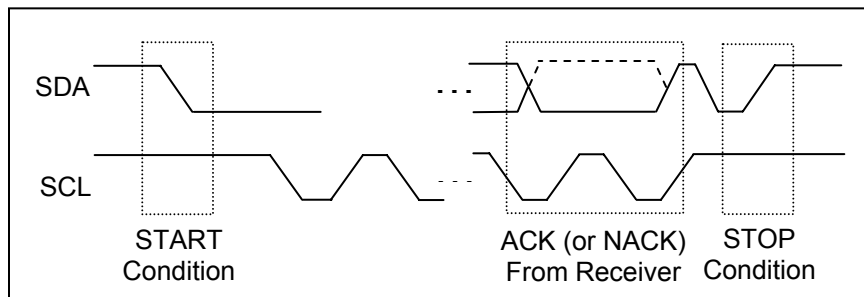

Figure 7. Control Byte

bit 7	bit 6	bit 5	bit 4	bit 3	bit 2	bit 1	bit 0
1	0	0	1	A ₂	A ₁	A ₀	R/W

GENERAL 2-WIRE INFORMATION

- All data is transmitted MSb first over the 2-wire bus.
- One bit of data is transmitted on the 2-wire bus each SCL period.
- A pullup resistor is required on the SDA line and, when the bus is idle, both SDA and SCL must remain in a logic-high state.
- All bus communication must be initiated with a START condition and terminated with a STOP condition. During a START or STOP is the only time SDA is allowed to change states while SCL is high. At all other times, changes on the SDA line can only occur when SCL is low: SDA must remain stable when SCL is high.
- After every 8-bit (1-byte) transfer, the receiving device must answer with an ACK (or NACK), which takes one SCL period. Therefore, nine clocks are required for every one-byte data transfer.

INITIATING 2-WIRE COMMUNICATION

To initiate 2-wire communication, the master generates a START followed by a control byte containing the DS620 slave address. The R/W bit of the control byte must be a 0 (write) since the master next writes a command byte or an address byte. The DS620 responds with an ACK after receiving the control byte. This must be followed by a command byte from the master which indicates what type of command operation is to be performed, or an address byte when the master intends to write to or read from the DS620. The DS620 again responds with an ACK after receiving the command or address byte. The master can then issue a STOP to signal the end of the communication sequence, or continue writing to the address memory. See the *Command Set* section for details on

the DS620 commands. See *Writing to the DS620* or *Reading from the DS620* for more information on reading from and writing to the DS620.

WRITING TO THE DS620

The master can write data to the DS620 by issuing an address byte following the control byte. The $R\bar{W}$ bit in the control byte must be a 0 (write). After receiving an ACK from the DS620 in response to the control byte, the master sends the address of the first register byte to be written, loading the address counter with the desired location. The DS620 responds with another ACK, after which the master sends the data to be written. After receiving each byte of data, the DS620 responds with an ACK. The master continues to write data to successive address locations until it indicates there is no more data to be written by sending a STOP or repeated START condition. The DS620 ignores any data written once the address increments past ADh, the last defined register in the DS620 memory, and indicates this by sending a NACK after each byte. It also ignores data written to undefined addresses A8h and A9h. All writes to the DS620 are made to the shadow RAM. Once data is written to the shadow RAM, it is only stored to EEPROM by issuance of a Copy Data command from the master. At that time all registers are copied to EEPROM, except the Temperature registers, which are SRAM only, and the undefined registers. The DS620 must be set to the continuous conversion mode and be actively converting temperature to enable the Copy Data command to function properly. See *Copying to EEPROM Command Sequence* for more information.

READING FROM THE DS620

The master can read data from the DS620 by issuing an address byte following the control byte. The $R\bar{W}$ bit in the control byte must be a 0 (write). After receiving an ACK from the DS620 in response to the control byte, the master writes the address of the first register byte to be read, loading the address counter with the desired location. The DS620 will respond with another ACK. The master then must issue a repeated START (or a STOP and a START) followed by a control byte with the same slave address as the first control byte. However, this time the $R\bar{W}$ bit must be a 1 which tells the DS620 that a “read” is being performed. After the DS620 sends an ACK in response to this control byte, it begins transmitting the requested data on the next clock cycle. The master responds with an ACK between each byte of data read from the DS620 until no further bytes of data are to be read, at which time the master responds with a NACK followed by a STOP. The DS620 sends all 1's (FFh) once the address increments past ADh, the last defined register in the DS620 memory. There is no guaranteed state of data read from the undefined registers, A8h and A9h. The Recall Data command should be issued before a read to assure that the contents of the EEPROM will be in the Shadow RAM when read.

COMMAND SET

The DS620 command set is detailed below:

Start Convert [51h] 0101 0001

Initiates temperature conversions. If the part is in one-shot mode (1SHOT = 1), only one conversion is performed. In continuous mode (1SHOT = 0), continuous temperature conversions are performed until a Stop Convert command is issued (even if 1SHOT is changed to a 1).

Stop Convert [22h] 0010 0010

Stops temperature conversions when the device is in continuous conversion mode (1SHOT = 0). This command has no function if the device is in one-shot mode (1SHOT = 1)

Recall Data [B8h] 1011 1000

Refreshes SRAM shadow register with EEPROM data.

Copy Data [48h] 0100 1000

Copies data from all SRAM shadow registers to EEPROM.

NOTE: The DS620 must be set to the continuous conversion mode and be actively converting temperature to enable the Copy Data command to function properly. See example command sequence in the *Copying to EEPROM Command Sequence* section for more information.

Software POR [54h] 0101 0100

Initiates a software power-on-reset (POR), which stops temperature conversions and resets all registers and logic to their power-up states. The software POR allows the user to simulate cycling the power without actually powering down the device. This command should not be issued while a Copy Data command is in progress.

COPYING TO EEPROM COMMAND SEQUENCE

Data is written to DS620 and then copied from SRAM to EEPROM

BUS MASTER MODE	DS620 MODE	DATA (MSB FIRST)	COMMENTS	SEQUENCE NUMBER
TX	RX	START	Bus master initiates a START condition.	1
TX	RX	<address, 0>	Bus master sends DS620 address, R/W = 0.	2
RX	TX	ACK	DS620 generates acknowledge bit.	3
TX	RX	A4h	Bus master sends the address location of the first byte of data to be written. (In this case the first byte of user EEPROM).	4
RX	TX	ACK	DS620 generates acknowledge.	5
TX	RX	<data>	Bus master sends one byte of data to the SRAM location for EEPROM address A4h.	6
RX	TX	ACK	DS620 generates acknowledge.	7
TX	RX	<data>	Bus master sends one byte of data to the SRAM location for EEPROM for address A5h.	8
RX	TX	ACK	DS620 generates acknowledge.	9
TX	RX	<data>	Bus master sends one byte of data to the SRAM location for EEPROM for address A6h.	10
RX	TX	ACK	DS620 generates acknowledge.	11
TX	RX	<data>	Bus master sends one byte of data to the SRAM location for EEPROM for address A7h.	12
RX	TX	ACK	DS620 generates acknowledge.	13
TX	RX	START	Bus master generates a repeated start condition.	14
TX	RX	<address, 0>	Bus master sends DS620 address, R/W = 0.	15
RX	TX	ACK	DS620 generates acknowledge.	16
TX	RX	ACh	Bus master sends the address location of the MSb of the configuration register (contains the 1SHOT bit). This writes to the SRAM location corresponding the EEPROM location. NOTE: Sequence numbers 17 through 23 need to be done only if DS620 is in 1SHOT mode: 1SHOT = 1.	17
RX	TX	ACK	DS620 generates acknowledge.	18
TX	RX	xxxxxx0b	Bus master writes to the configuration register putting the DS620 in continuous conversion mode: 1SHOT = 0.	19
RX	TX	ACK	DS620 generates acknowledge.	20
TX	RX	START	Bus master generates a repeated start condition.	21
TX	RX	<address, 0>	Bus master sends DS620 address, R/W = 0.	22
RX	TX	ACK	DS620 generates acknowledge	23
TX	RX	51h	Master sends START CONVERT command to DS620 to start temperature conversions.	24
RX	TX	ACK	DS620 generates acknowledge bit and begins conversions.	25
TX	RX	START	Bus master generates a repeated start condition.	26
TX	RX	<address, 0>	Bus master sends DS620 address, R/W = 0.	27
RX	TX	ACK	DS620 generates acknowledge.	28
TX	RX	ACh	Bus master sends the address location of the MSb of the configuration register (contains the 1SHOT bit). This writes to the SRAM location corresponding the EEPROM location. NOTE: command sequence numbers 29 through 34 need only be done if a return to 1SHOT mode operation is needed.	29

RX	TX	ACK	DS620 generates acknowledge.	30
TX	RX	xxxxxxx1b	Bus master writes to the configuration register putting the DS620 back in 1SHOT mode: 1SHOT = 1.	31
TX	RX	START	Bus master generates a repeated start condition.	32
TX	RX	<address, 0>	Bus master sends DS620 address, R/W = 0.	33
RX	TX	ACK	DS620 generates acknowledge.	34
TX	RX	48h	Master sends COPY DATA command to DS620 to copy data in from SRAM memory to EEPROM memory.	35
RX	TX	ACK	DS620 generates acknowledge.	36
TX	RX	START	Bus master generates a repeated start condition.	37
TX	RX	<address, 0>	Bus master sends DS620 address, R/W = 0.	38
RX	TX	ACK	DS620 generates acknowledge.	39
TX	RX	22h	Bus master sends a STOP CONVERT command to stop the DS620 from continuously converting temperature. NOTE: Bus master should ensure that EEPROM copy operation is complete before executing the STOP CONVERT command by either waiting 10ms from the time of the COPY DATA command or checking the NVB bit in configuration register	40
RX	TX	ACK	DS620 generates acknowledge.	41
TX	RX	STOP	Bus master sends STOP condition to end communication with DS620. (The bus master could send a repeated start condition if additional communication with the DS620 is desired.)	42

WRITING THE 1SHOT BIT COMMAND SEQUENCE

Configuring from continuous mode to 1SHOT mode.

BUS MASTER MODE	DS620 MODE	DATA (MSB FIRST)	COMMENTS	SEQUENCE NUMBER
TX	RX	START	Bus master initiates a START condition.	1
TX	RX	<address, 0>	Bus master sends DS620 address, R/W = 0.	2
RX	TX	ACK	DS620 generates acknowledge bit.	3
TX	RX	51h	Master sends START CONVERT command to DS620 to start temperature conversions.	4
RX	TX	ACK	DS620 generates acknowledge bit and begins conversions.	5
TX	RX	START	Bus master generates a repeated start condition.	6
TX	RX	<address, 0>	Bus master sends DS620 address, R/W = 0.	7
RX	TX	ACK	DS620 generates acknowledge.	8
TX	RX	ACh	Bus master sends the address location of the MSb of the configuration register (contains the 1SHOT bit). This writes to the SRAM location corresponding the EEPROM location.	9
RX	TX	ACK	DS620 generates acknowledge.	10
TX	RX	xxxxxxx1b	Bus master writes to the configuration register putting the DS620 in 1SHOT mode: 1SHOT = 1.	11
RX	TX	ACK	DS620 generates acknowledge.	12
TX	RX	START	Bus master generates a repeated start condition.	13
TX	RX	<address, 0>	Bus master sends DS620 address, R/W = 0.	14
RX	TX	ACK	DS620 generates acknowledge.	15
TX	RX	48h	Master sends COPY DATA command to DS620 to copy data in from SRAM memory to EEPROM memory.	16

RX	TX	ACK	DS620 generates acknowledge.	17
TX	RX	START	Bus master generates a repeated start condition.	18
TX	RX	<address, 0>	Bus master sends DS620 address, R/W = 0.	19
RX	TX	ACK	DS620 generates acknowledge.	20
TX	RX	22h	Bus master sends STOP CONVERT command to stop the DS620 from continuously converting temperature. NOTE: Bus master should ensure that EEPROM copy operation is complete before executing the STOP CONVERT command by either waiting 10ms from the time of the COPY DATA command or checking the NVB bit in configuration register	21
RX	TX	ACK	DS620 generates acknowledge.	22
TX	RX	STOP	Bus master sends STOP condition to end communication with DS620. (The bus master could send a repeated start condition if additional communication with the DS620 is desired.)	23

Configuring from 1SHOT to mode to continuous conversion mode.

BUS MASTER MODE	DS620 MODE	DATA (MSB FIRST)	COMMENTS	SEQUENCE NUMBER
TX	RX	START	Bus master initiates a START condition.	1
TX	RX	<address, 0>	Bus master sends DS620 address, R/W = 0.	2
RX	TX	ACK	DS620 generates acknowledge bit.	3
TX	RX	ACh	Bus master sends the address location of the MSb of the configuration register (contains the 1SHOT bit). This writes to the SRAM location corresponding the EEPROM location.	4
RX	TX	ACK	DS620 generates acknowledge.	5
TX	RX	xxxxxx0b	Bus master writes to the configuration register putting the DS620 in continuous conversion mode: 1SHOT = 0.	6
RX	TX	ACK	DS620 generates acknowledge.	7
TX	RX	START	Bus master generates a repeated start condition.	8
TX	RX	<address, 0>	Bus master sends DS620 address, R/W = 0.	9
RX	TX	ACK	DS620 generates acknowledge.	10
TX	RX	51h	Master sends START CONVERT command to DS620 to start temperature conversions.	11
RX	TX	ACK	DS620 generates acknowledge bit and begins conversions.	12
TX	RX	START	Bus master generates a repeated start condition.	13
TX	RX	<address, 0>	Bus master sends DS620 address, R/W = 0.	14
RX	TX	ACK	DS620 generates acknowledge.	15
TX	RX	48h	Master sends COPY DATA command to DS620 to copy data in from SRAM memory to EEPROM memory.	16
RX	TX	ACK	DS620 generates acknowledge.	17
TX	RX	STOP	Bus master sends STOP condition to end communication with DS620. (The bus master could send a repeated start condition if additional communication with the DS620 is desired.)	18

Компания «Океан Электроники» предлагает заключение долгосрочных отношений при поставках импортных электронных компонентов на взаимовыгодных условиях!

Наши преимущества:

- Поставка оригинальных импортных электронных компонентов напрямую с производств Америки, Европы и Азии, а так же с крупнейших складов мира;
- Широкая линейка поставок активных и пассивных импортных электронных компонентов (более 30 млн. наименований);
- Поставка сложных, дефицитных, либо снятых с производства позиций;
- Оперативные сроки поставки под заказ (от 5 рабочих дней);
- Экспресс доставка в любую точку России;
- Помощь Конструкторского Отдела и консультации квалифицированных инженеров;
- Техническая поддержка проекта, помощь в подборе аналогов, поставка прототипов;
- Поставка электронных компонентов под контролем ВП;
- Система менеджмента качества сертифицирована по Международному стандарту ISO 9001;
- При необходимости вся продукция военного и аэрокосмического назначения проходит испытания и сертификацию в лаборатории (по согласованию с заказчиком);
- Поставка специализированных компонентов военного и аэрокосмического уровня качества (Xilinx, Altera, Analog Devices, Intersil, Interpoint, Microsemi, Actel, Aeroflex, Peregrine, VPT, Syfer, Eurofarad, Texas Instruments, MS Kennedy, Miteq, Cobham, E2V, MA-COM, Hittite, Mini-Circuits, General Dynamics и др.);

Компания «Океан Электроники» является официальным дистрибьютором и эксклюзивным представителем в России одного из крупнейших производителей разъемов военного и аэрокосмического назначения «JONHON», а так же официальным дистрибьютором и эксклюзивным представителем в России производителя высокотехнологичных и надежных решений для передачи СВЧ сигналов «FORSTAR».



JONHON

«JONHON» (основан в 1970 г.)

Разъемы специального, военного и аэрокосмического назначения:

(Применяются в военной, авиационной, аэрокосмической, морской, железнодорожной, горно- и нефтедобывающей отраслях промышленности)

«FORSTAR» (основан в 1998 г.)

ВЧ соединители, коаксиальные кабели,
кабельные сборки и микроволновые компоненты:

(Применяются в телекоммуникациях гражданского и специального назначения, в средствах связи, РЛС, а так же военной, авиационной и аэрокосмической отраслях промышленности).



Телефон: 8 (812) 309-75-97 (многоканальный)

Факс: 8 (812) 320-03-32

Электронная почта: ocean@oceanchips.ru

Web: <http://oceanchips.ru/>

Адрес: 198099, г. Санкт-Петербург, ул. Калинина, д. 2, корп. 4, лит. А