

48 x 48 Max. Counting Speed 40 KHZ Orange backlit LCD display Part number 87621111



- Counter, Tachometer, Chronometer, Multi-totalizer, Batch counter, Preselection totalizer
- Maximum input frequency 40 k Hz
- Simple parameter setting, configuration using text menus
- Easy modification of presets
- Scaling factor
- 5 A changeover relay and solid state output
- Removable connectors
- Backlit LCD display (orange) : 2 lines, 6 digits or multicoloured display (green-red)
- IP 65 sealed panel
- Option of locking the keypad, completely or partially (preset, programming)
- Accessories for 72 x 72 or 55 x 55 cut-out, DIN rail adaptor

Part numbers

| Type | Functions | Preset | Voltages | Output |
|-------------------------------------|--|--------|------------|-----------------------------------|
| 87621111 Orange backlit LCD display | Counter, Tachometer, Chronometer, Preselection multi-totalizer | 1 | 10 →30 VDC | 1 changeover relay, 1 solid state |

Specifications

Physical details and protection

| | |
|-------------------------------------|---|
| Supply | 10 →30 VDC / 24 V AC / 90 →260 VAC |
| Relative humidity (no condensation) | EN 60068-2-30 40/93 % RLF |
| Altitude | 0 < 2000 m |
| Certifications | UL - cULus (pending) - CE |
| Vibration resistance in 3 axes | 10-55 Hz/1 min/XYZ EN 60068-2-6 : 30 min. in each direction |
| Connection by screw terminals | Removable |
| Protection | Conforming to standard EN 60529 IP65 for panel/IP20 for connections |
| Front panel watertight seal | ■ |
| Temperature limits use (°C) | -20 →+65 |
| Temperature limits stored (°C) | -25 →+75 |
| Weight (g) | 150 DC version 250 AC version |

General characteristics

| | |
|--|---|
| Reset to zero or to preset | On panel : if not locked during programming Electrical : automatic, voltage or solid state (NPN or PNP depending on programming) |
| Minimum pulse time | Impulse counter : < 15 ms Chronometer : 500 µs |
| Option to protect against reset from front panel | ■ |
| Scale factor (each input pulse is multiplied by this figure) | 00,0001 →99,9999 |
| Scaling factor (each input impulse is divided by this value) | 01,0000 →99,9999 |
| Decimal point selectable for ease of reading | 0 0,0 0,00 0,000 0,0000 0,00000 |
| Sensor supply version AC | 24 VDC -20/+15 % 50 mA |
| Programming and current value backed up via EEPROM memory | ■ Service life 10 years |

Operating characteristics

| | |
|--------------------|---|
| Functions | Preselection counter, Tachometer, Chronometer, Multi-totalizer, Batch counters, Totalizer |
| Number of presets | 1 or 2 |
| Display | LCD with orange backlighting/Multicoloured LCD (green-red) |
| Height digits (mm) | LCD 9 |
| Display details | - 999 999 →999 999 |

Inputs specifications

| | |
|-------------|---|
| Inputs | 2 counter inputs 1 reset input, 1 gate input |
| Input modes | Dir : Directional AS : up/dn AA : up/up PP : phase PP2 : phase 2 PP4 : phase 4 |
| Input type | Voltage or solid state |
| High level | 8 VDC→30 VDC |
| Low level | 0 →2 VDC |

Solid state output characteristics

| | |
|-----------------|---|
| Maximum current | 30 mA |
| Max. voltage | 10 →30 VDC for the DC version 24 VDC -20/+15 % |

Relay output characteristics

| | |
|-------------------------------------|----------------------|
| Changeover relay | • |
| NO contact | Depending on version |
| Maximum current | 5 A |
| Minimum current | 10 mA |
| Maximum voltage | 30 VDC / 250 VAC |
| Min. voltage | 5 VAC/DC |
| Response time | < 13 ms |
| Mechanical life (operations) | 20 x 10 ⁶ |
| Number of operations to 5 A | 5 x 10 ⁴ |
| Output modes : maintained or pulsed | 0.01 →99.99 s |

Accessories

| Description | Code |
|--------------------------------|----------|
| Adaptor for 72 x 72 mm cut-out | 26546842 |
| Adaptor for 55 x 55 mm cut-out | 26546846 |
| DIN rail adaptor | 26546841 |

Principles

| N° | Legend |
|----|--|
| 1 | Current value |
| 2 | Selected value |
| 3 | Chronometer display |
| 4 | Active output indication |
| 5 | Prog/mode button |
| 6 | Preset control buttons |
| 7 | Button required for programming parameters |
| 8 | Shows which value is displayed |

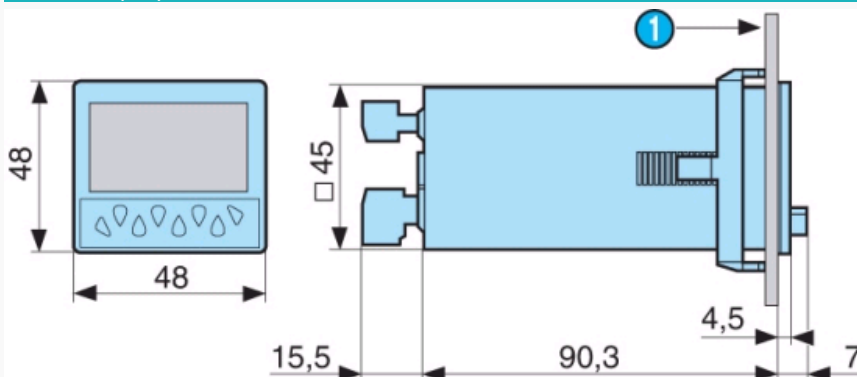
Dimensions (mm)

| N° | Legend |
|----|-----------|
| ① | 10.5 max. |

Dimensions (mm)

26546842 - Adaptor for 72 x 72 mm cut-out

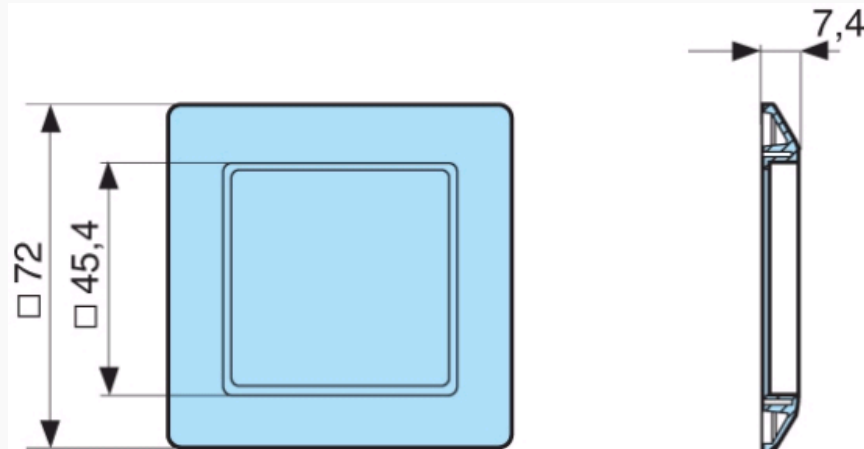

Dimensions (mm)

26546846 - Adaptor for 55 x 55 mm cut-out



Dimensions (mm)

Panel cut-out

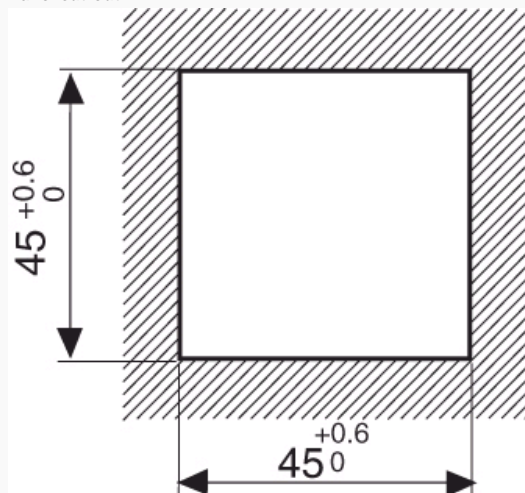

Dimensions (mm)

26546841 - DIN rail adaptor

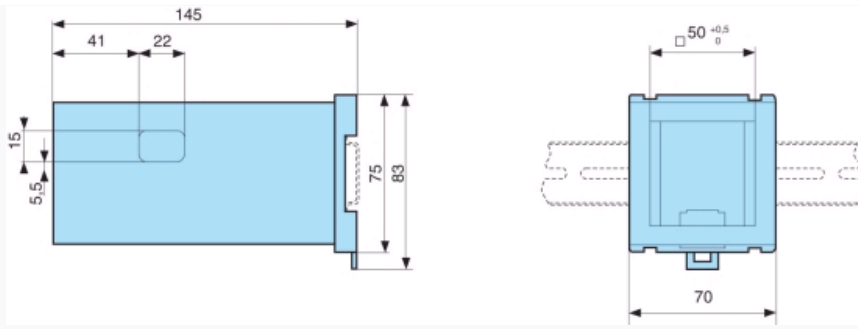

Curves

Counter : dir

dir

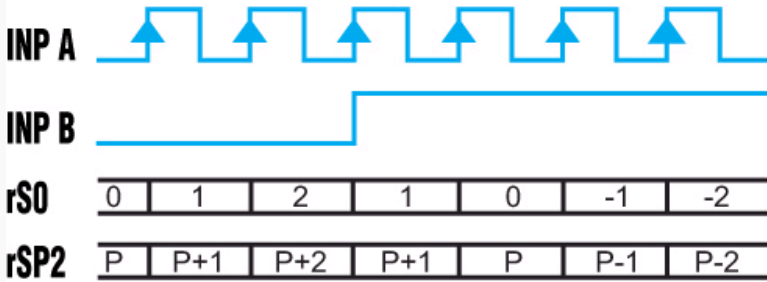

Inp A : counter input Inp B : count direction rS0 : Display 0 →Preset rSP2 : Display Preset →0

Curves

Counter : AS

AS

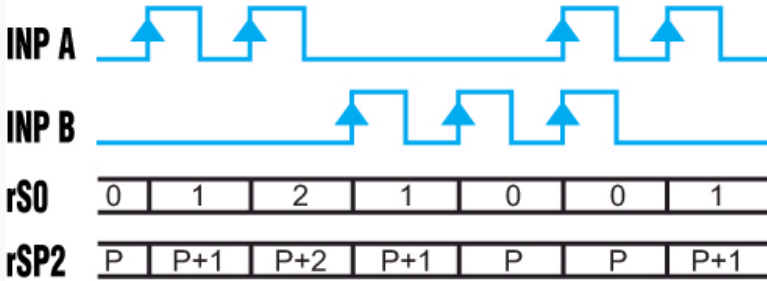

Inp A : Add. counter input 1 Inp B : Sous. counter input 2 rS0 : Display 0 →Preset rSP2 : Display Preset →0

Curves

Counter : AA

AA

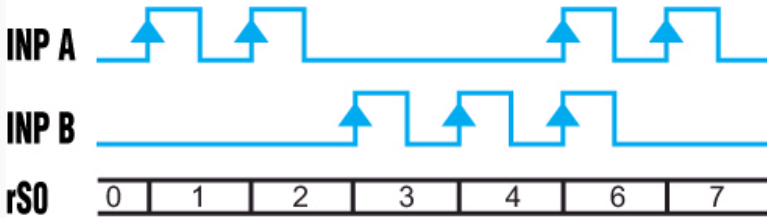

Inp A : Add. counter input 1 Inp B : Sous. counter input 2 rS0 : Display 0 →Preset

Curves

Counter : PP

PP

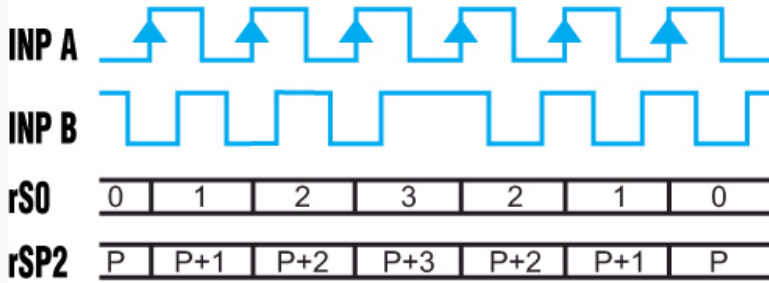

A 90° B Inp A : Counter input Counting on an edge Inp B : Reversal of direction rS0 : Display 0 →Preset rSP2 : Display Preset →0

Curves

Counter : PP2

PP2

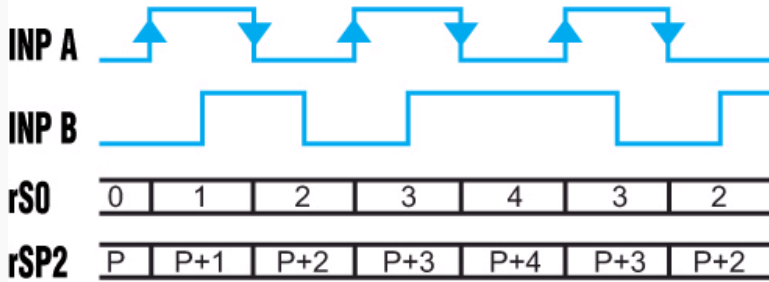

A 90° B Inp A : Counter input Counting on a rising edge and on a falling edge Inp B : Reversal of direction rS0 : Display 0 →Preset rSP2 : Display Preset →0

Curves

Counter : PP4

PP4

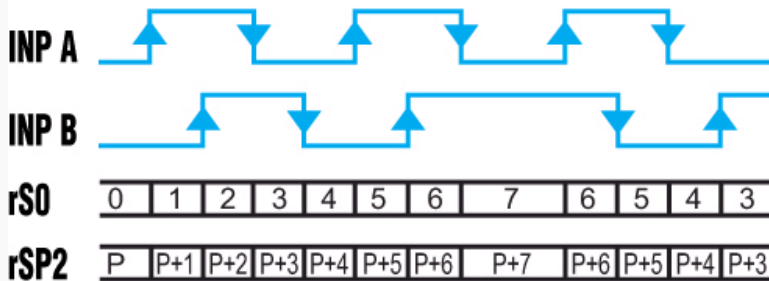

A 90° B Inp A : Counter input Counting on a rising edge and on a falling edge Inp B : Counter input Counting on a rising edge and on a falling edge, reversal of direction rS0 : Display 0 →Preset rSP2 : Display Preset →0

Curves

Chronometer : Start tcCb

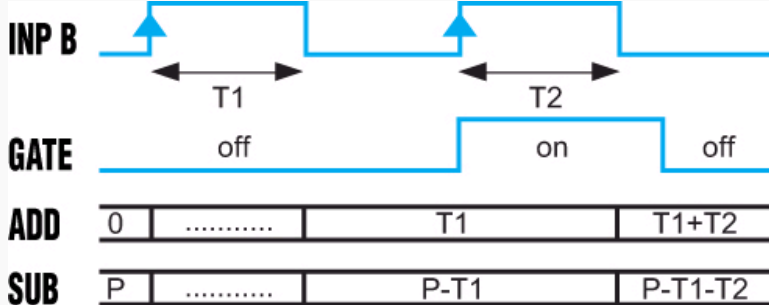

Inp A : No function Inp B : On/Off Cumulative time counting Add : Display 0 →Preset Sub : Display Preset →0

Curves

Chronometer : Start tcCbb

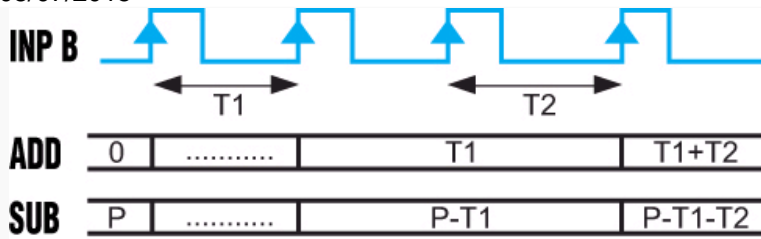

Inp A : No function Inp B : On/Off Cumulative time counting Add : Display 0 →Preset Sub : Display Preset →0

Curves

Chronometer : Start tcCAb

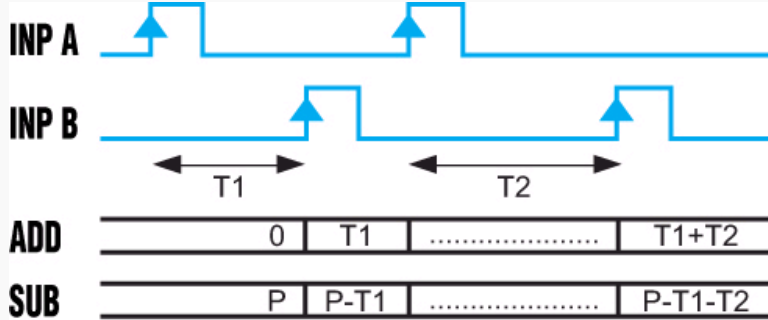

Inp A : On Inp B : Off Cumulative time counting Add : Display 0 →Preset Sub : Display Preset →0

Curves

Chronometer : Start tcSb

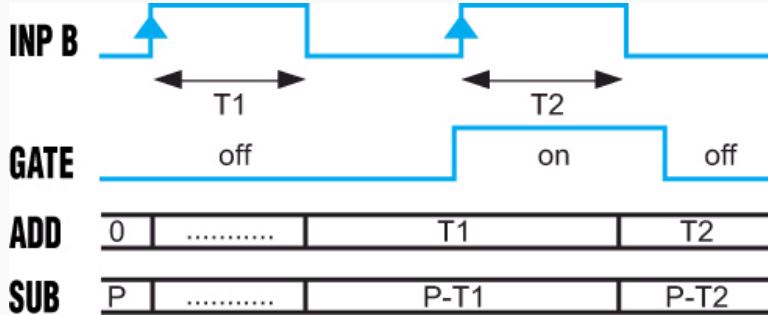

Inp A : No function Inp B : On/Off Individual time counting while B is active, automatic reset before each new count Add : Display 0 →Preset Sub : Display Preset →0

Curves

Chronometer : Start tcSbb

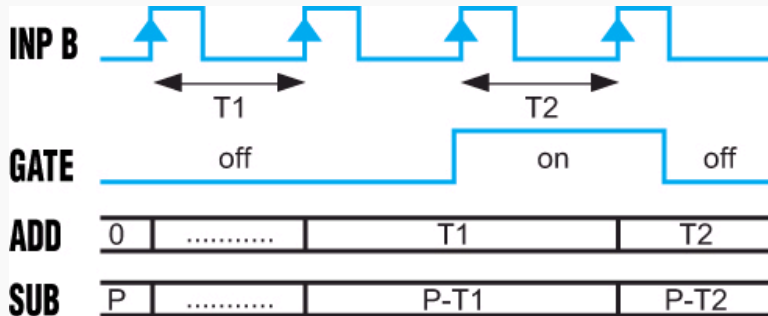

Inp A : No function Inp B : On/Off Individual time counting, automatic reset before each new count Add : Display 0 →Preset Sub : Display Preset →0

Curves

Chronometer : Start tcSAB

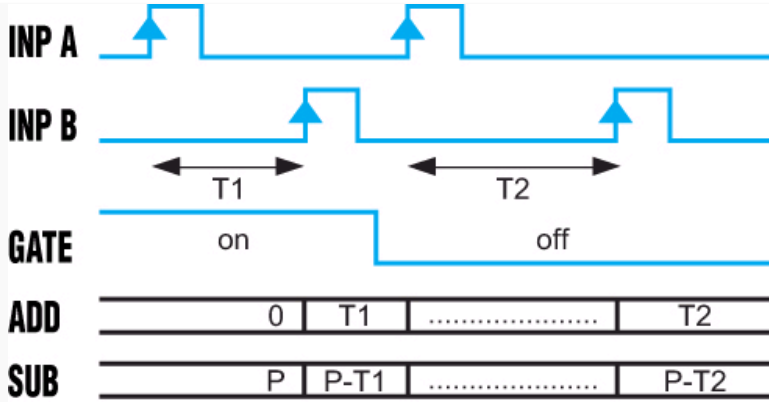

Inp A : On Inp B : Off Individual time counting, automatic reset before each new count Add : Display 0 →Preset Sub : Display Preset →0

Curves

Chronometer : Start tcAuto

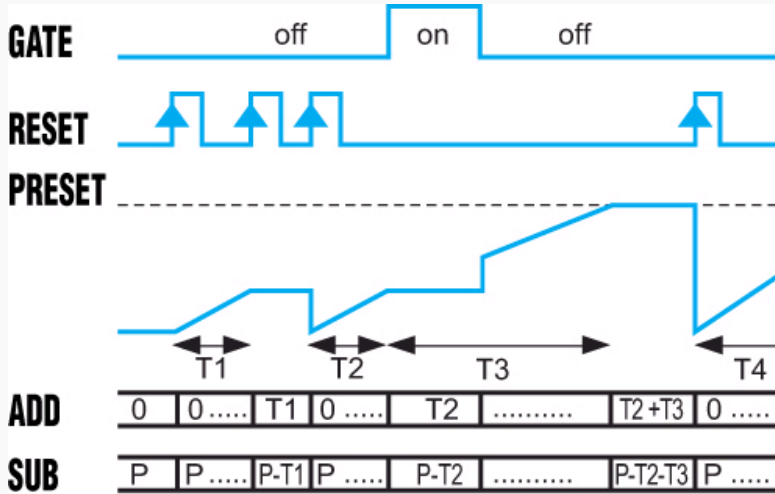

Inp A : No function Inp B : No function Time counting command via Reset (manual or electrical) Add : Display 0 →Preset Sub : Display Preset →0 The Gate input has a display memory function

Curves

Tachometer : Start tA.A

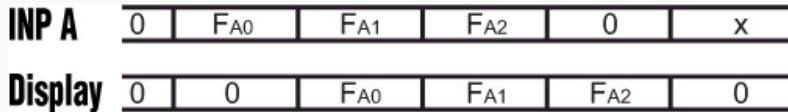

Inp A : Frequency input Inp B : No function

Curves

Tachometer : Start tA.AS



Inp A : Frequency input 1 Inp B : Frequency input 2 Formula : A - B

Curves

Tachometer : Start tA.AA

| | | | | | | |
|----------------|---|-----|-----|-----------|-----------|-----|
| INP A | 0 | FA0 | FA1 | FA2 | 0 | x |
| INP B | 0 | 0 | FB0 | FB1 | FB2 | x |
| Display | 0 | 0 | FA0 | FA0 + FB0 | FA1 + FB1 | FB2 |

Inp A : Frequency input 1 Inp B : Frequency input 2 Formula : A + B

Curves

Tachometer : Start tA.PP

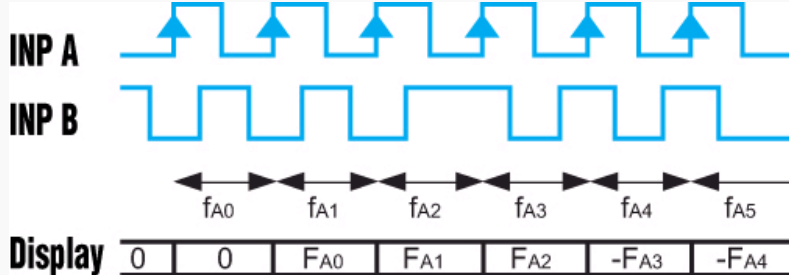

A 90° B Inp A : Frequency input 1 Inp B : Reversal of direction

Curves

Output operation : OutoP rS0

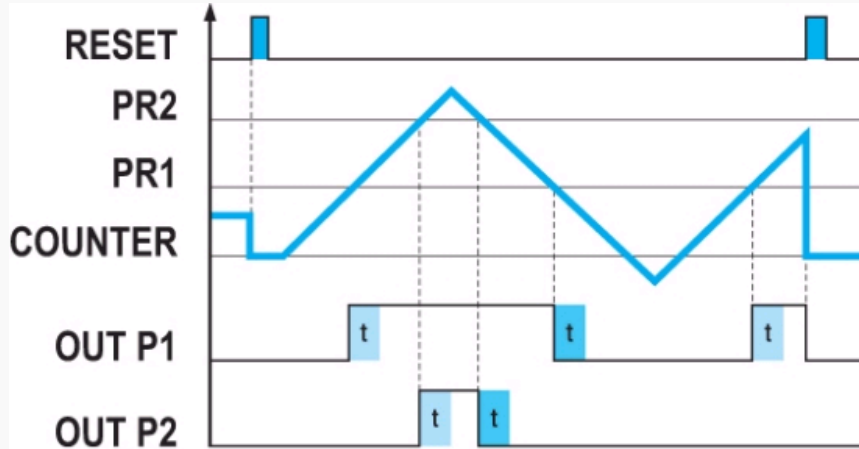

A 90° B Inp A : Frequency input 1 Inp B : Reversal of direction

Curves

Output operation : OutoP rSA0

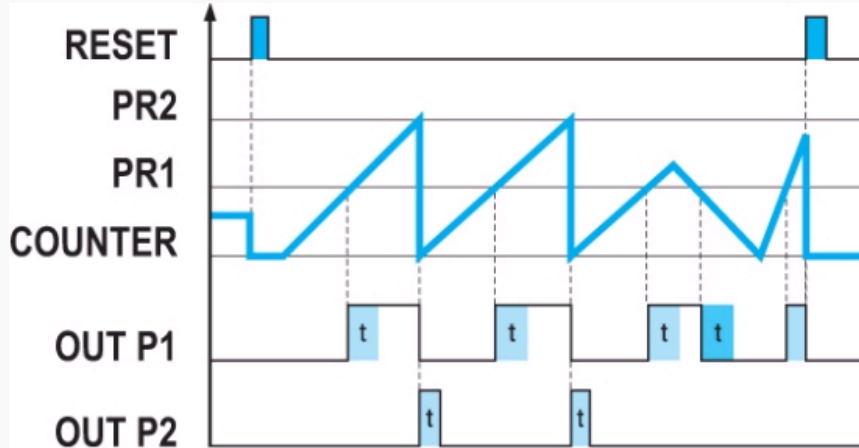

A 90° B Inp A : Frequency input 1 Inp B : Reversal of direction

Curves

Output operation : OutoP bCrSA0

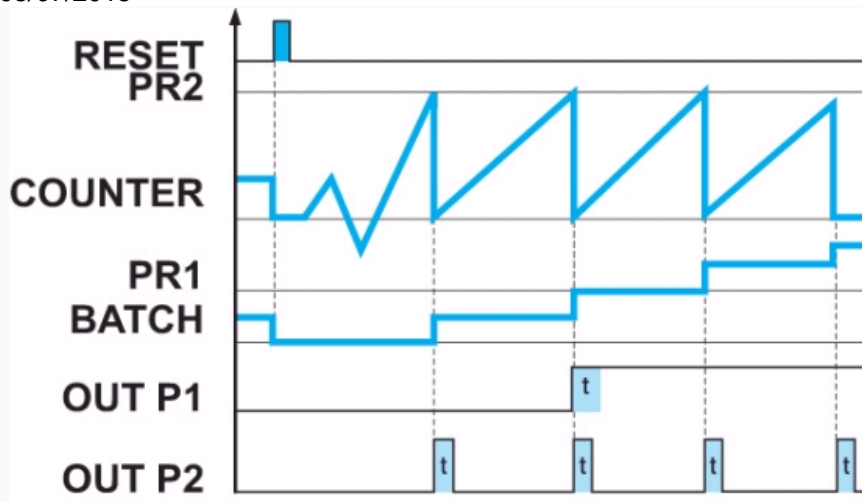

A 90° B Inp A : Frequency input 1 Inp B : Reversal of direction

Curves

Output operation : OutoP tCrSA0

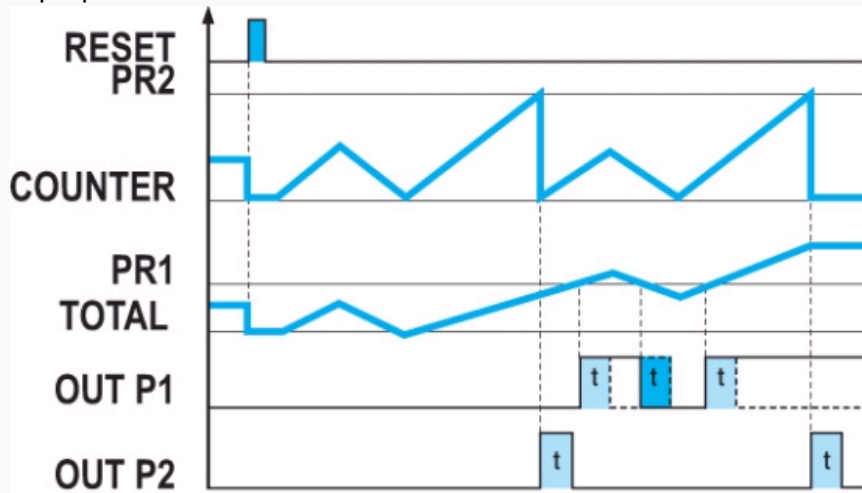

A 90° B Inp A : Frequency input 1 Inp B : Reversal of direction

Curves

Output operation : OutoP rSP2

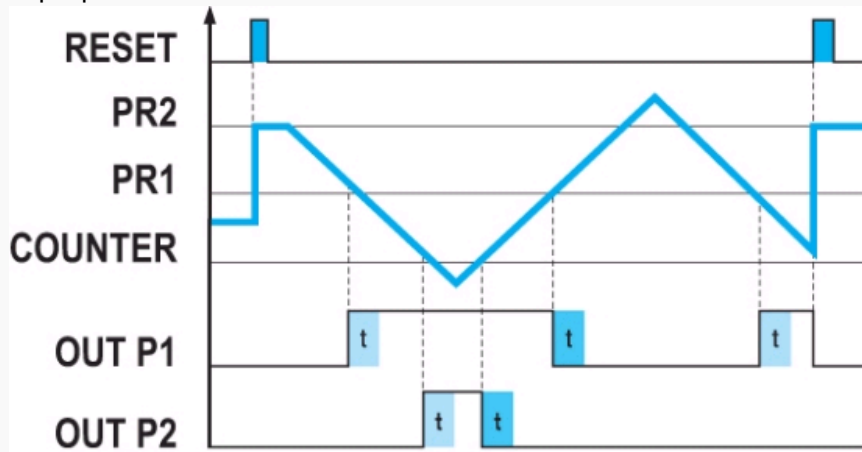

A 90° B Inp A : Frequency input 1 Inp B : Reversal of direction

Curves

Output operation : OutoP rSAP2

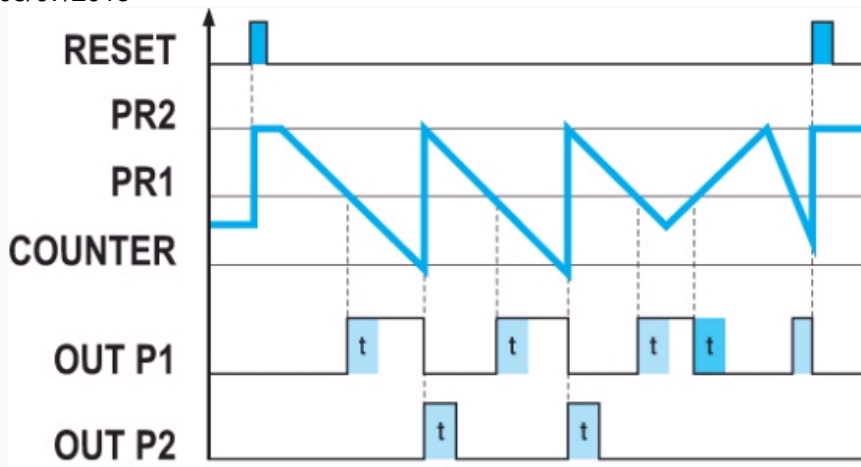

A 90° B Inp A : Frequency input 1 Inp B : Reversal of direction

Curves

Output operation : OutoPbCrSA2



A 90° B Inp A : Frequency input 1 Inp B : Reversal of direction

Curves

Output operation : OutoP tCrSA2

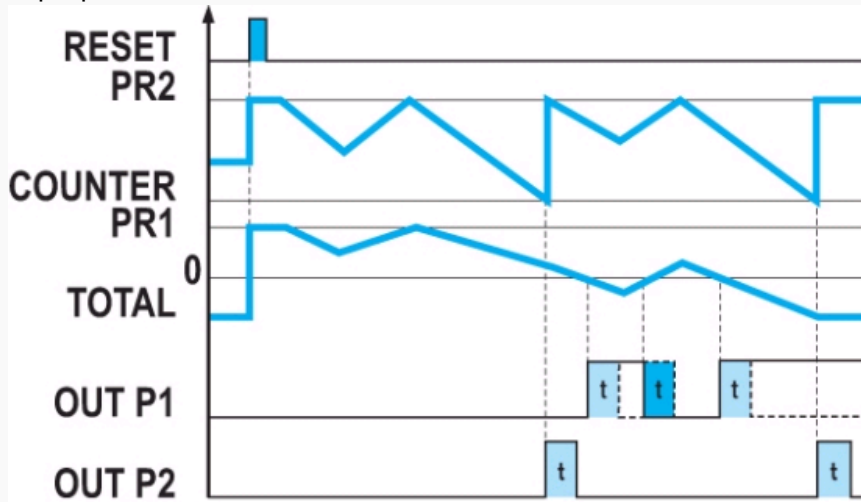

A 90° B Inp A : Frequency input 1 Inp B : Reversal of direction

Curves

Output operation : OutoP bCrS0

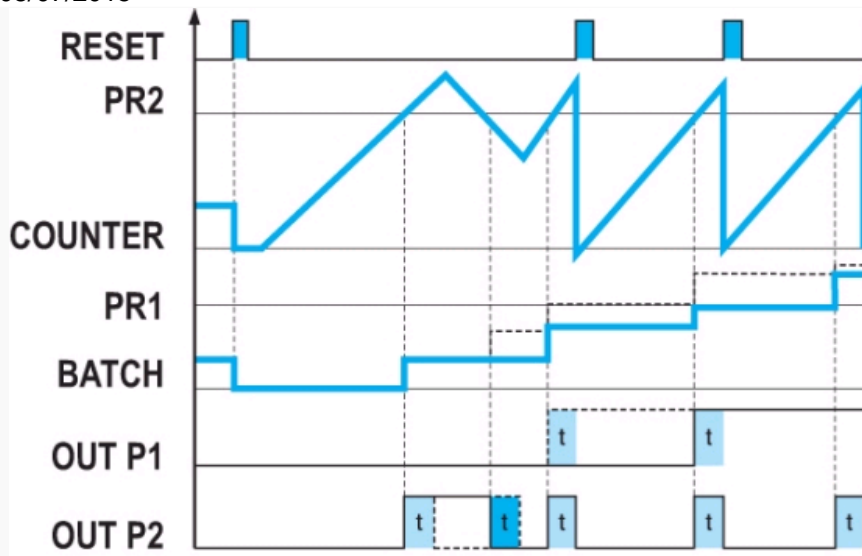

A 90° B Inp A : Frequency input 1 Inp B : Reversal of direction

Curves

Output operation : OutoP tCrS0

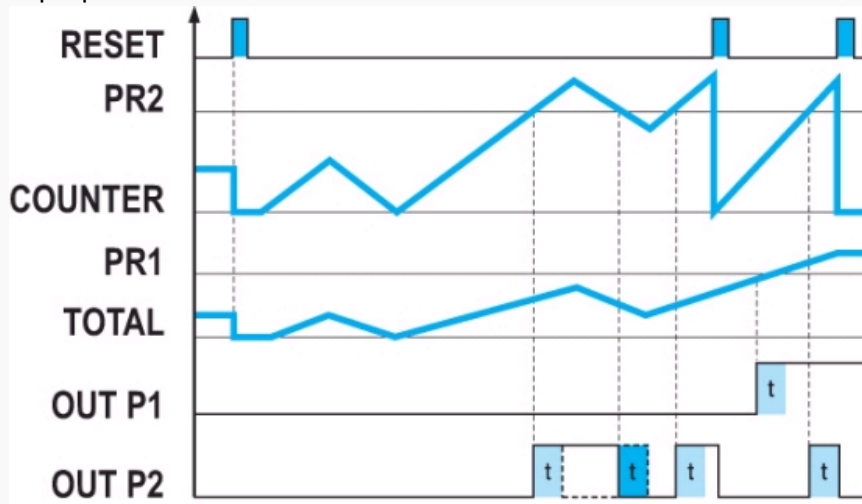

A 90° B Inp A : Frequency input 1 Inp B : Reversal of direction

Curves

Output operation : OutoP MurS0 (AA)



A 90° B Inp A : Frequency input 1 Inp B : Reversal of direction

Curves

Output operation : OutoP bCrSP2



A 90° B Inp A : Frequency input 1 Inp B : Reversal of direction

Curves

Output operation : OutoP tCrSP2



A 90° B Inp A : Frequency input 1 Inp B : Reversal of direction

Curves

Output operation : OutoP MurS0 (AS)

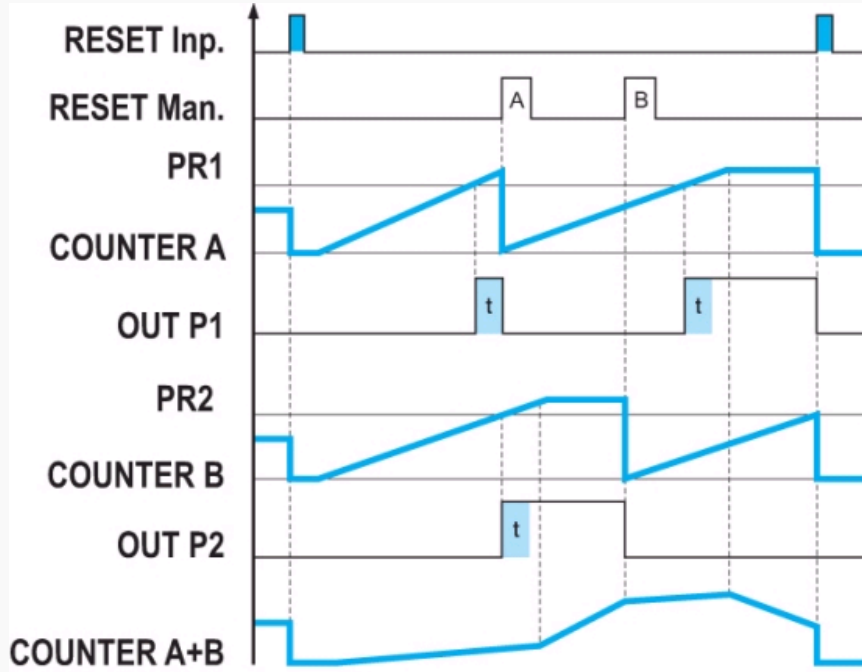

A 90° B Inp A : Frequency input 1 Inp B : Reversal of direction

Connections

87621111 / 211

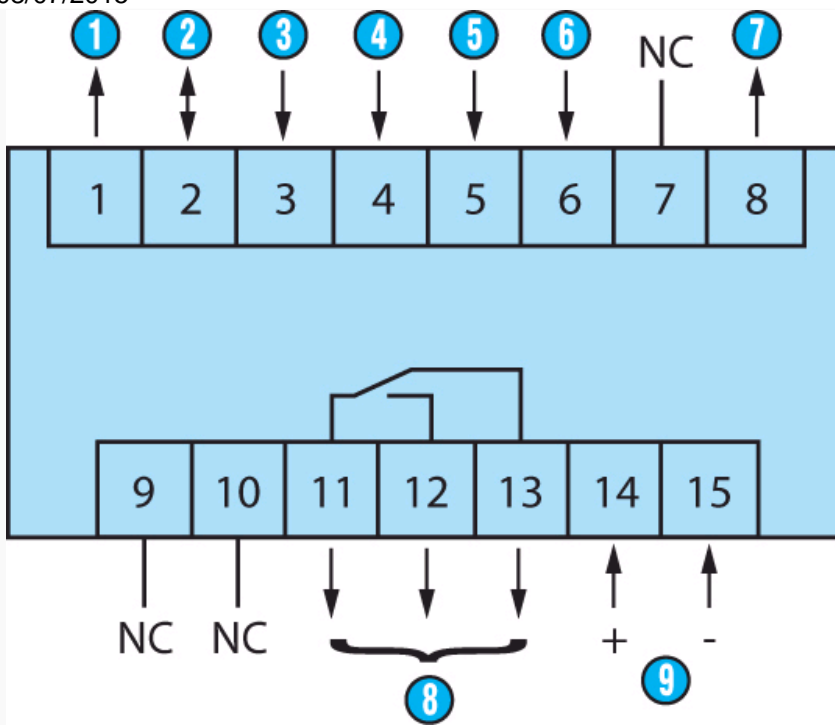

Output : 5 A/250 VAC/AC : 24 VAC

| N° | Legend |
|----|---|
| ① | Sensor voltage supply (* UB interconnected) |
| ② | GND (0 VDC) |
| ③ | INP A (signal A input) |
| ④ | INP B (signal B input) |
| ⑤ | Reset (Reset input) |
| ⑥ | Gate input |
| ⑦ | Output 1 - 10-30 VDC/30 mA |
| ⑧ | 11-12-13 : Output 1 |
| ⑨ | 14-15 : Supply |

Connections

87621112 / 212

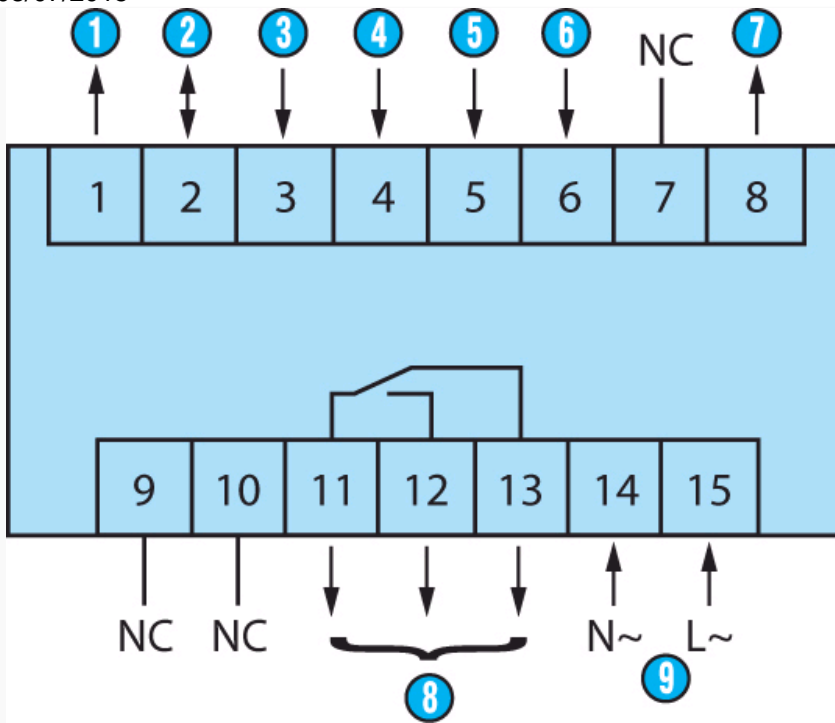

Output : 5 A/250 VAC/AC : 24 VAC

| N° | Legend |
|----|-------------------------|
| ① | Sensor voltage supply |
| ② | GND (0 VDC) |
| ③ | INP A (signal A input) |
| ④ | INP B (signal B input) |
| ⑤ | Reset (Reset input) |
| ⑥ | Gate input |
| ⑦ | Output 1 - 24 VDC/30 mA |
| ⑧ | 11-12-13 : Output 1 |
| ⑨ | 14-15 : Supply |

Connections

87621115 / 215

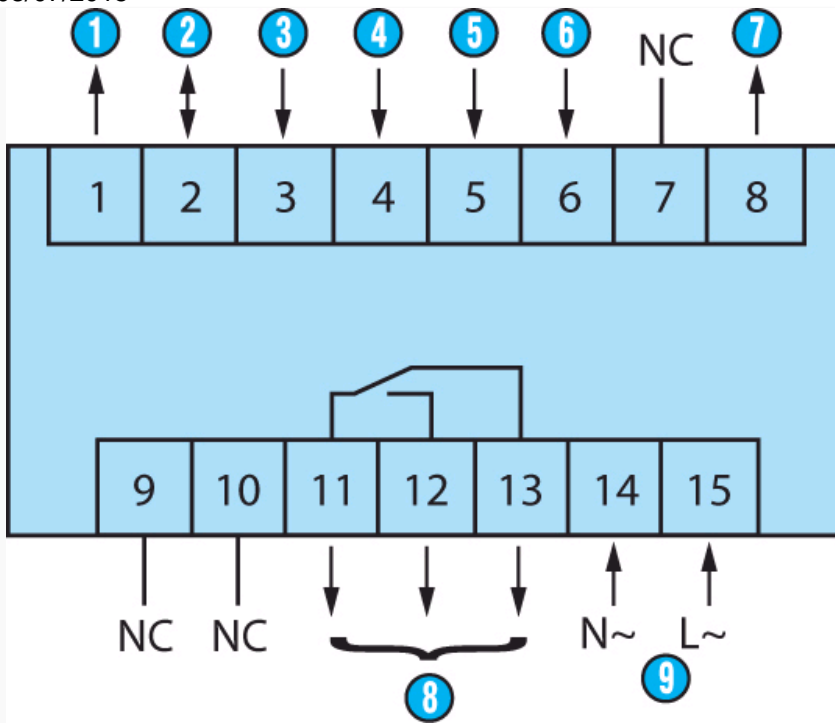

Output : 5 A/250 VAC/DC : 10 30 VDC

| N° | Legend |
|----|-------------------------|
| ① | Sensor voltage supply |
| ② | GND (0 VDC) |
| ③ | INP A (signal A input) |
| ④ | INP B (signal B input) |
| ⑤ | Reset (Reset input) |
| ⑥ | Gate input |
| ⑦ | Output 1 - 24 VDC/30 mA |
| ⑧ | 11-12-13 : Output 1 |
| ⑨ | 14-15 : Supply |

Connections

87621121 / 221

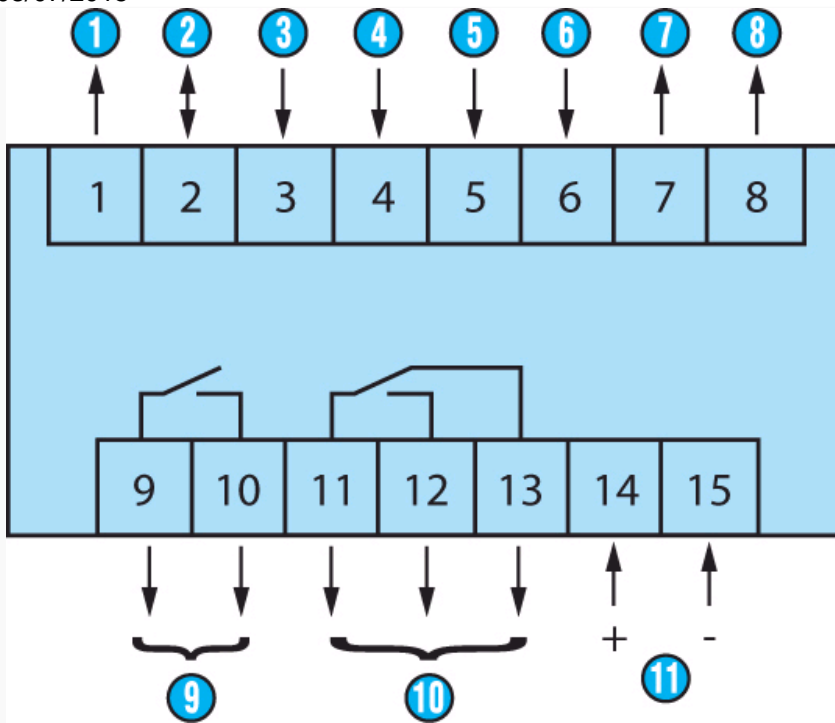

Output : 5 A/250 VAC/AC : 90 260 VDC

| N° | Legend |
|----|---|
| ① | Sensor voltage supply (* UB interconnected) |
| ② | GND (0 VDC) |
| ③ | INP A (signal A input) |
| ④ | INP B (signal B input) |
| ⑤ | Reset (Reset input) |
| ⑥ | Gate input |
| ⑦ | Output 1 : 10-30 VDC/30 mA |
| ⑧ | Output 2 : 10-30 VDC/30 mA |
| ⑨ | 9-10 : Output 1 |
| ⑩ | 11-12-13 : Output 2 |
| ⑪ | 14-15 : Supply |

Connections

87621122 / 222

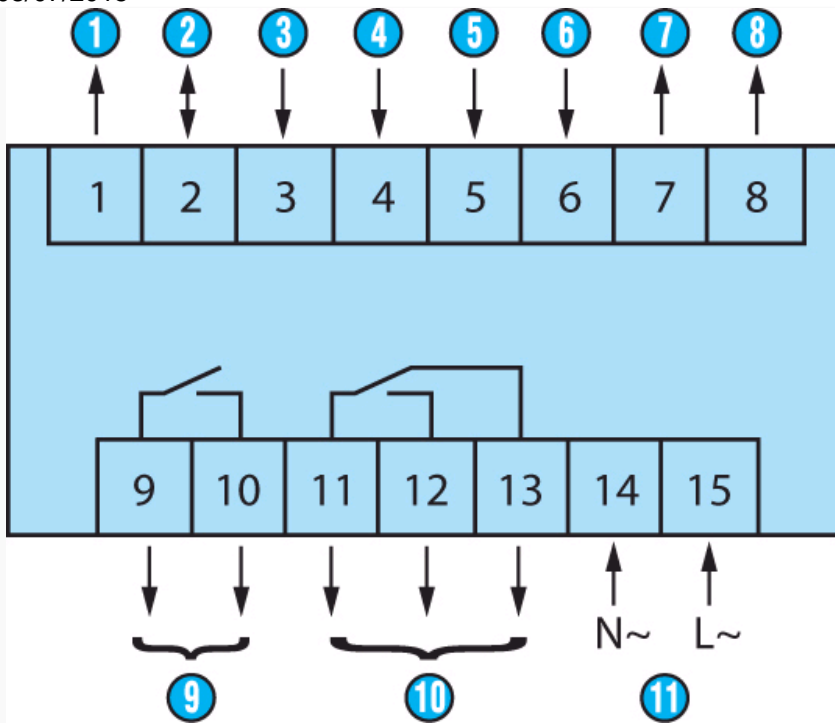

Output : 5 A/250 VAC/AC : 90 260 VDC

| N° | Legend |
|----|-------------------------|
| ① | Sensor voltage supply |
| ② | GND (0 VDC) |
| ③ | INP A (signal A input) |
| ④ | INP B (signal B input) |
| ⑤ | Reset (Reset input) |
| ⑥ | Gate input |
| ⑦ | Output 1 : 24 VDC/30 mA |
| ⑧ | Output 2 : 24 VDC/30 mA |
| ⑨ | 9-10 : Output 1 |
| ⑩ | 11-12-13 : Output 2 |
| ⑪ | 14-15 : Supply |

Connections

87621125 / 225



Output : 5 A/250 VAC/AC : 90 260 VDC

| N° | Legend |
|----|-------------------------|
| ① | Sensor voltage supply |
| ② | GND (0 VDC) |
| ③ | INP A (signal A input) |
| ④ | INP B (signal B input) |
| ⑤ | Reset (Reset input) |
| ⑥ | Gate input |
| ⑦ | Output 1 : 24 VDC/30 mA |
| ⑧ | Output 2 : 24 VDC/30 mA |
| ⑨ | 9-10 : Output 1 |
| ⑩ | 11-12-13 : Output 2 |
| ⑪ | 14-15 : Supply |

Applications

Programming diagram

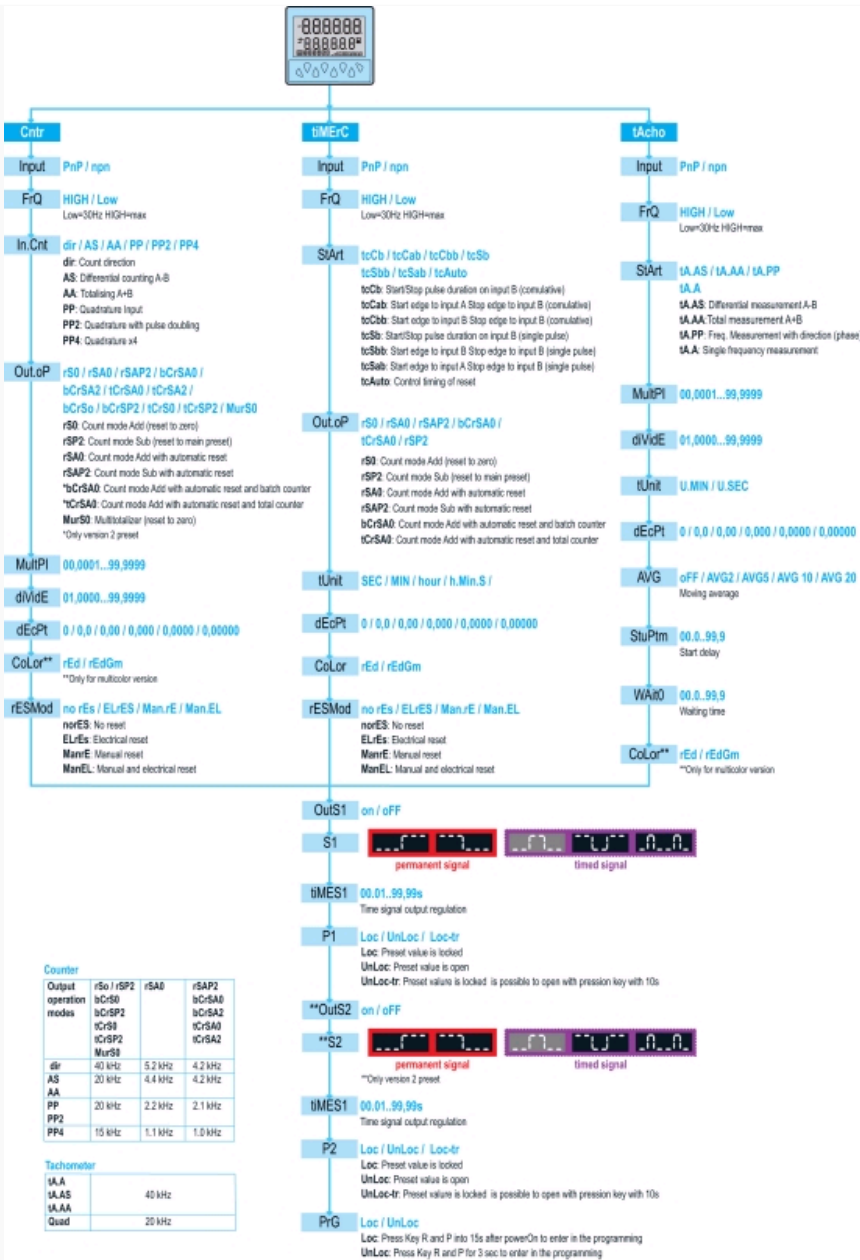

Компания «Океан Электроники» предлагает заключение долгосрочных отношений при поставках импортных электронных компонентов на взаимовыгодных условиях!

Наши преимущества:

- Поставка оригинальных импортных электронных компонентов напрямую с производств Америки, Европы и Азии, а так же с крупнейших складов мира;
- Широкая линейка поставок активных и пассивных импортных электронных компонентов (более 30 млн. наименований);
- Поставка сложных, дефицитных, либо снятых с производства позиций;
- Оперативные сроки поставки под заказ (от 5 рабочих дней);
- Экспресс доставка в любую точку России;
- Помощь Конструкторского Отдела и консультации квалифицированных инженеров;
- Техническая поддержка проекта, помощь в подборе аналогов, поставка прототипов;
- Поставка электронных компонентов под контролем ВП;
- Система менеджмента качества сертифицирована по Международному стандарту ISO 9001;
- При необходимости вся продукция военного и аэрокосмического назначения проходит испытания и сертификацию в лаборатории (по согласованию с заказчиком);
- Поставка специализированных компонентов военного и аэрокосмического уровня качества (Xilinx, Altera, Analog Devices, Intersil, Interpoint, Microsemi, Actel, Aeroflex, Peregrine, VPT, Syfer, Eurofarad, Texas Instruments, MS Kennedy, Miteq, Cobham, E2V, MA-COM, Hittite, Mini-Circuits, General Dynamics и др.);

Компания «Океан Электроники» является официальным дистрибьютором и эксклюзивным представителем в России одного из крупнейших производителей разъемов военного и аэрокосмического назначения «JONHON», а так же официальным дистрибьютором и эксклюзивным представителем в России производителя высокотехнологичных и надежных решений для передачи СВЧ сигналов «FORSTAR».



JONHON

«JONHON» (основан в 1970 г.)

Разъемы специального, военного и аэрокосмического назначения:

(Применяются в военной, авиационной, аэрокосмической, морской, железнодорожной, горно- и нефтедобывающей отраслях промышленности)

«FORSTAR» (основан в 1998 г.)

ВЧ соединители, коаксиальные кабели, кабельные сборки и микроволновые компоненты:

(Применяются в телекоммуникациях гражданского и специального назначения, в средствах связи, РЛС, а так же военной, авиационной и аэрокосмической отраслях промышленности).



Телефон: 8 (812) 309-75-97 (многоканальный)

Факс: 8 (812) 320-03-32

Электронная почта: ocean@oceanchips.ru

Web: <http://oceanchips.ru/>

Адрес: 198099, г. Санкт-Петербург, ул. Калинина, д. 2, корп. 4, лит. А