

## Film Dielectric Trimmers

**TEST VOLTAGE (DC) FOR 1 MINUTE:**

600 V

**MAXIMUM CONTACT RESISTANCE:**5 m $\Omega$ **MINIMUM INSULATION RESISTANCE BETWEEN STATOR AND ROTOR:**10 000 M $\Omega$ **CATEGORY TEMPERATURE RANGE:**

- 40 to + 125 °C

**CLIMATIC CATEGORY (IEC 60068):**

40/125/21

**MINIMUM STORAGE TEMPERATURE:**

- 55 °C

**RELATED SPECIFICATION:**

IEC 60418-1 and 4

**EFFECTIVE ANGLE OF ROTATION:**

180° (rotation in 180° only, see "Life of Trimmer")

**OPERATING TORQUE:****C<sub>max</sub> < 3.5 pF**

1 to 15 mNm

**C<sub>max</sub> ≥ 3.5 pF**

1 to 20 mNm

**MAXIMUM AXIAL THRUST:**

2 N

**FEATURES**

- High temperature type
- Housing dimensions:  
6 mm x 8 mm x 9 mm
- For a basic grid of 2.54 mm
- Top and bottom adjustment
- Round head
- Vertical version

**APPLICATIONS**

- For fine adjustment in professional applications

**DESCRIPTION:**

The trimmers consist of a polysulphone housing, brass rotor and plated brass stator with PTFE film as the dielectric. The stator plate tags are heat sealed to the housing.

The rotor contact surfaces are plated to ensure a long life and a stable contact even under severe climatic conditions. A coloured dot indicates the maximum capacitance.

Cleaning with solvents is not advised.

Versions are available with either a round head or hexagonal head.

Both versions have top adjustment by means of a screwdriver or trimming key and bottom adjustment by means of a key.

**QUALITY LEVEL:**

Sampling and data evaluation for quality level in accordance with "MIL-STD-105D" and "IEC 60410":

- < 0.15 % major defects
- < 0.65 % minor defects

Each capacitor is tested for minimum C<sub>max</sub> and is also subjected to the full test voltage.

**C<sub>min</sub>/C<sub>max</sub>:**

0.5/2 to 2/18 pF

**RATED VOLTAGE (DC):**

300 V

**LIFE OF TRIMMER:**

Maximum 10 cycles: rotation in 180° only (the electrical and mechanical performance is not guaranteed if rotated beyond 10 cycles)

**RoHS**  
COMPLIANT

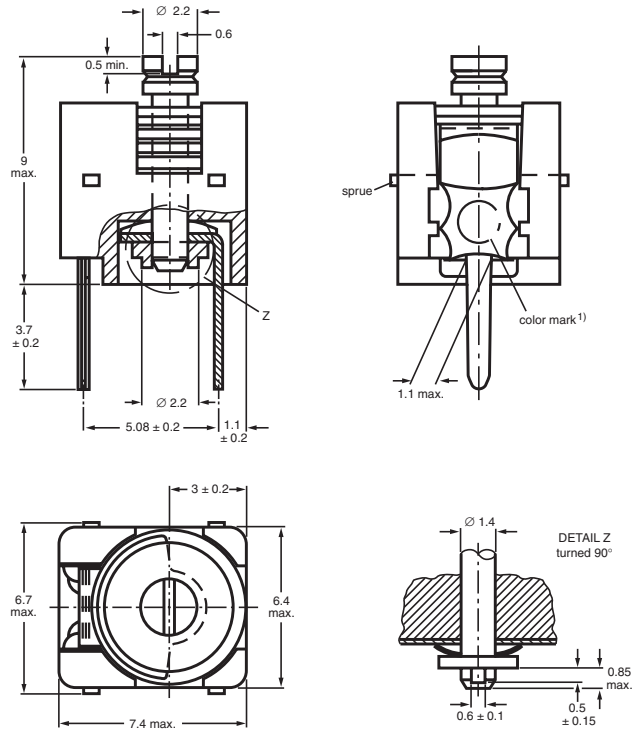

Trimmers BFC2 809 05... series, with round heads

Dimensions in millimeters

**ADJUSTMENT**

For top adjustment a screwdriver or trimming key can be used; for bottom adjustment a key is required as shown below

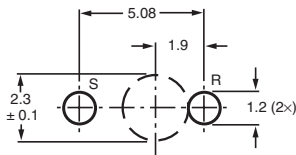

Hole pattern

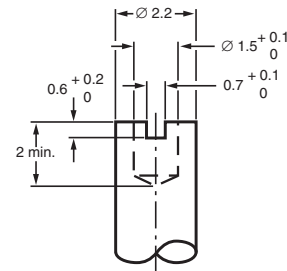

Bottom adjustment key

**ORDERING INFORMATION**

$C_{min}/C_{max}$ (pF)	CATALOG NUMBER BFC2 809 05...	
	TOP AND BOTTOM ADJUSTMENT	
	ROUND HEAD	ROUND HEAD AND FLUX GUARD
0.5/2	011	-
1.2/3.5	215	001
1.8/10	216	002
2/18	217	003

**MOUNTING**

The trimmer can be mounted on printed-circuit boards with a minimum hole diameter of 2.54 mm.

**PACKAGING**

Blister packs of 70 units each. For smallest packaging quantity (SPQ) see Electrical Data Table.

**ELECTRICAL DATA**

GUARANTEED MAX. $C_{min}/$ MIN. $C_{max}$ AT 200 kHz (pF)	SHAPE OF HEAD	FIG.	TAN $\delta$ AT $C_{max} \times 10^{-4}$		TEMP. COEFF. <sup>1)</sup> ( $10^{-6}/K$ )	MIN. $f_{res}$ AT $C_{max}$ (MHz)	COL. OF DOT	SPQ	CATALOG NUMBER BFC2 ... ..
			1 MHz	100 MHz					
0.5/2	round	1	$\leq 10$	$\leq 20$	- 250 $\pm$ 350	1200	none	700	.... 809 05011
1.2/3.5	round	1	$\leq 10$	$\leq 20$	- 250 $\pm$ 350	850	orange	700	.... 809 05001
								700	.... 809 05215
1.8/10	round	1	$\leq 10$	$\leq 20$	- 250 $\pm$ 350	1200	none	700	.... 809 05002
							white	700	.... 809 05216
2/18	round	1	$\leq 10$	$\leq 25$	- 250 $\pm$ 350	360	red	700	.... 809 05217
								700	.... 809 05003

**Note:**

1. C: 60 % to 80 % of  $C_{max}$ ;  $T_{amb}$ : from + 20 °C to + 125 °C

**TEST PROCEDURES AND REQUIREMENTS**

IEC 60418-1 CLAUSE	IEC 60068 TEST METHOD	TEST	PROCEDURE	REQUIREMENTS
4.2		method of mounting	method A	
14		capacitance drift	after TC measurement	$\Delta C/C: \leq 2.5 \%$ ; 4 % for 2 pF
19		thrust	axial thrust of 2 N	$\Delta C/C: \leq 0.3 \%$
21 21.1 21.2	Ua Ub	robustness of terminations: tensile bending	1 N 1 cycle	no damage no damage
22	Na	rapid change of temperature	1 cycle; 0.5 hours at lower and 0.5 hours at upper category temperature	$\Delta C/C: \leq 2.5 \%$

IEC 60418-1 CLAUSE	IEC 60068 TEST METHOD	TEST	PROCEDURE	REQUIREMENTS
23	T Ta Tb	soldering: solderability  resistance to heat	solder bath immersion 3 mm; 235 °C; 2 s  solder bath: 260 °C; 10 s	good wetting no mechanical damage no mechanical damage
24	Eb	impact bump	4000 ± 10 bumps; 40 g; 6 ms	$\Delta C/C \leq 0.6 \%$ ; no mechanical damage
25	Fc	vibration	frequency 10 to 55 Hz; amplitude 0.35 mm; 1.5 hours	$\Delta C/C \leq 0.6 \%$ ; no mechanical damage
26 26.1  26.2 26.3 26.5	B  D Aa	climatic sequence: dry heat  damp heat accelerated, first cycle cold  damp heat accelerated, remaining cycles	16 hours at upper category temperature  1 cycle; 24 hours; + 40 °C; 95 to 100 % RH 16 hours; - 40 °C  1 cycle; 24 hours; + 40 °C; 95 to 100 % RH	$\Delta C/C \leq 2.5$ $\tan \delta \leq 10 \times 10^{-4}$ for $C_{\max} < 18 \text{ pF}$ ; $\tan \delta \leq 40 \times 10^{-4}$ for $C_{\max} \geq 18 \text{ pF}$ $R_{\text{ins}} \geq 10\,000 \text{ M}\Omega$ ; rotor contact R: $\leq 5 \text{ m}\Omega$ voltage proof: 600 V for 1 minute visual examination: no mechanical damage operating torque: 1 to 20 mNm
27	Ca	damp heat steady state	21 days; + 40 °C; 90 to 95 % RH	$\Delta C/C \leq 2.5 \%$ $\tan \delta \leq 10 \times 10^{-4}$ for $C_{\max} < 18 \text{ pF}$ ; $\tan \delta \leq 25 \times 10^{-4}$ for $C_{\max} \geq 18 \text{ pF}$ $R_{\text{ins}} \geq 10\,000 \text{ M}\Omega$ ; rotor contact R: $\leq 5 \text{ m}\Omega$ voltage proof: 600 V for 1 minute visual examination: no mechanical damage operating torque: 1 to 20 mNm
29		mechanical endurance	10 cycles  Maximum 10 cycles: rotation in 180° only (the electrical and mechanical performance is not guaranteed if rotated beyond 10 cycles)	$\Delta C/C \leq 0.3 \%$ ; $\leq 2.5 \%$ for 2 pF $\Delta C/C$ after axial thrust: $\leq 0.3 \%$ ; rotor contact R: $\leq 5 \text{ m}\Omega$ voltage proof: 600 V for 1 minute visual examination: no mechanical damage operating torque: 1 to 20 mNm



## Disclaimer

ALL PRODUCT, PRODUCT SPECIFICATIONS AND DATA ARE SUBJECT TO CHANGE WITHOUT NOTICE TO IMPROVE RELIABILITY, FUNCTION OR DESIGN OR OTHERWISE.

Vishay Intertechnology, Inc., its affiliates, agents, and employees, and all persons acting on its or their behalf (collectively, "Vishay"), disclaim any and all liability for any errors, inaccuracies or incompleteness contained in any datasheet or in any other disclosure relating to any product.

Vishay makes no warranty, representation or guarantee regarding the suitability of the products for any particular purpose or the continuing production of any product. To the maximum extent permitted by applicable law, Vishay disclaims (i) any and all liability arising out of the application or use of any product, (ii) any and all liability, including without limitation special, consequential or incidental damages, and (iii) any and all implied warranties, including warranties of fitness for particular purpose, non-infringement and merchantability.

Statements regarding the suitability of products for certain types of applications are based on Vishay's knowledge of typical requirements that are often placed on Vishay products in generic applications. Such statements are not binding statements about the suitability of products for a particular application. It is the customer's responsibility to validate that a particular product with the properties described in the product specification is suitable for use in a particular application. Parameters provided in datasheets and/or specifications may vary in different applications and performance may vary over time. All operating parameters, including typical parameters, must be validated for each customer application by the customer's technical experts. Product specifications do not expand or otherwise modify Vishay's terms and conditions of purchase, including but not limited to the warranty expressed therein.

Except as expressly indicated in writing, Vishay products are not designed for use in medical, life-saving, or life-sustaining applications or for any other application in which the failure of the Vishay product could result in personal injury or death. Customers using or selling Vishay products not expressly indicated for use in such applications do so at their own risk. Please contact authorized Vishay personnel to obtain written terms and conditions regarding products designed for such applications.

No license, express or implied, by estoppel or otherwise, to any intellectual property rights is granted by this document or by any conduct of Vishay. Product names and markings noted herein may be trademarks of their respective owners.

## Material Category Policy

**Vishay Intertechnology, Inc. hereby certifies that all its products that are identified as RoHS-Compliant fulfill the definitions and restrictions defined under Directive 2011/65/EU of The European Parliament and of the Council of June 8, 2011 on the restriction of the use of certain hazardous substances in electrical and electronic equipment (EEE) - recast, unless otherwise specified as non-compliant.**

**Please note that some Vishay documentation may still make reference to RoHS Directive 2002/95/EC. We confirm that all the products identified as being compliant to Directive 2002/95/EC conform to Directive 2011/65/EU.**

**Vishay Intertechnology, Inc. hereby certifies that all its products that are identified as Halogen-Free follow Halogen-Free requirements as per JEDEC JS709A standards. Please note that some Vishay documentation may still make reference to the IEC 61249-2-21 definition. We confirm that all the products identified as being compliant to IEC 61249-2-21 conform to JEDEC JS709A standards.**

Компания «Океан Электроники» предлагает заключение долгосрочных отношений при поставках импортных электронных компонентов на взаимовыгодных условиях!

Наши преимущества:

- Поставка оригинальных импортных электронных компонентов напрямую с производств Америки, Европы и Азии, а так же с крупнейших складов мира;
- Широкая линейка поставок активных и пассивных импортных электронных компонентов (более 30 млн. наименований);
- Поставка сложных, дефицитных, либо снятых с производства позиций;
- Оперативные сроки поставки под заказ (от 5 рабочих дней);
- Экспресс доставка в любую точку России;
- Помощь Конструкторского Отдела и консультации квалифицированных инженеров;
- Техническая поддержка проекта, помощь в подборе аналогов, поставка прототипов;
- Поставка электронных компонентов под контролем ВП;
- Система менеджмента качества сертифицирована по Международному стандарту ISO 9001;
- При необходимости вся продукция военного и аэрокосмического назначения проходит испытания и сертификацию в лаборатории (по согласованию с заказчиком);
- Поставка специализированных компонентов военного и аэрокосмического уровня качества (Xilinx, Altera, Analog Devices, Intersil, Interpoint, Microsemi, Actel, Aeroflex, Peregrine, VPT, Syfer, Eurofarad, Texas Instruments, MS Kennedy, Miteq, Cobham, E2V, MA-COM, Hittite, Mini-Circuits, General Dynamics и др.);

Компания «Океан Электроники» является официальным дистрибьютором и эксклюзивным представителем в России одного из крупнейших производителей разъемов военного и аэрокосмического назначения «JONHON», а так же официальным дистрибьютором и эксклюзивным представителем в России производителя высокотехнологичных и надежных решений для передачи СВЧ сигналов «FORSTAR».



## JONHON

«JONHON» (основан в 1970 г.)

Разъемы специального, военного и аэрокосмического назначения:

(Применяются в военной, авиационной, аэрокосмической, морской, железнодорожной, горно- и нефтедобывающей отраслях промышленности)

«FORSTAR» (основан в 1998 г.)

ВЧ соединители, коаксиальные кабели,  
кабельные сборки и микроволновые компоненты:

(Применяются в телекоммуникациях гражданского и специального назначения, в средствах связи, РЛС, а так же военной, авиационной и аэрокосмической отраслях промышленности).



Телефон: 8 (812) 309-75-97 (многоканальный)

Факс: 8 (812) 320-03-32

Электронная почта: [ocean@oceanchips.ru](mailto:ocean@oceanchips.ru)

Web: <http://oceanchips.ru/>

Адрес: 198099, г. Санкт-Петербург, ул. Калинина, д. 2, корп. 4, лит. А