

S1JA Microcontroller Group

Datasheet

Renesas Synergy™ Platform

Synergy Microcontrollers

S1 Series

All information contained in these materials, including products and product specifications, represents information on the product at the time of publication and is subject to change by Renesas Electronics Corp. without notice. Please review the latest information published by Renesas Electronics Corp. through various means, including the Renesas Electronics Corp. website (<http://www.renesas.com>).

Ultra-low power 48-MHz Arm® Cortex®-M23 core, up to 256-KB code flash memory, 32-KB SRAM, Capacitive Touch Sensing Unit, 16-bit A/D Converter, 24-bit sigma-delta A/D Converter, 12-bit D/A Converter, 8-bit D/A Converter, Operational Amplifier, security and safety features.

Features

■ Arm Cortex-M23 Core

- Armv8-M architecture
- Maximum operating frequency: 48 MHz
- Arm Memory Protection Unit (Arm MPU) with 8 regions
- Debug and Trace: DWT, FPB, and CoreSight™ MTB-M23
- CoreSight Debug Port: SW-DP

■ Memory

- Up to 256-KB code flash memory
- 8-KB data flash memory (100,000 program/erase (P/E) cycles)
- Up to 32-KB SRAM
- Flash Cache (FCACHE)
- Memory Protection Unit (MPU)
- Memory Mirror Function (MMF)
- 128-bit unique ID

■ Connectivity

- USB 2.0 Full-Speed (USBFS) module
 - On-chip transceiver with voltage regulator
 - Compliant with USB Battery Charging Specification 1.2
- Serial Communications Interface (SCI) × 3
 - UART
 - Simple IIC
 - Simple SPI
- Serial Peripheral Interface (SPI) × 2
- I²C bus interface (IIC) × 2
- Controller Area Network (CAN) module

■ Analog

- 16-bit A/D Converter (ADC16)
 - 1.2 Msps
 - Differential input mode
 - Single-ended input mode
- 24-bit Sigma-Delta A/D Converter (SDADC24)
 - 15.6 ksp/s
 - Differential input mode
 - Single-ended input mode
- 12-bit D/A Converter (DAC12)
- 8-bit D/A Converter (DAC8) × 2
- High-Speed Analog Comparator (ACMPHS)
- Low-Power Analog Comparator (ACMPLP) × 2
- Operational Amplifier (OPAMP) × 3
- Temperature Sensor (TSN)

■ Timers

- General PWM Timer 32-bit (GPT32)
- General PWM Timer 16-bit (GPT16) × 6
- Asynchronous General-Purpose Timer (AGT) × 2
- Watchdog Timer (WDT)

■ Safety

- Error Correction Code (ECC) in SRAM
- SRAM parity error check
- Flash area protection
- ADC self-diagnosis function
- Clock Frequency Accuracy Measurement Circuit (CAC)
- Cyclic Redundancy Check (CRC) calculator
- Data Operation Circuit (DOC)
- Port Output Enable for GPT (POEG)
- Independent Watchdog Timer (IWDT)
- GPIO readback level detection
- Register write protection
- Main oscillator stop detection
- Illegal memory access

■ System and Power Management

- Low power modes
- Realtime Clock (RTC)
- Event Link Controller (ELC)
- Data Transfer Controller (DTC)
- Key Interrupt Function (KINT)
- Power-on reset
- Low Voltage Detection (LVD) with voltage settings

■ Security and Encryption

- AES128/256
- True Random Number Generator (TRNG)

■ Human Machine Interface (HMI)

- Capacitive Touch Sensing Unit (CTSUS)

■ Multiple Clock Sources

- Main clock oscillator (MOSC)
 - (1 to 20 MHz when VCC = 2.4 to 5.5 V)
 - (1 to 8 MHz when VCC = 1.8 to 5.5 V)
 - (1 to 4 MHz when VCC = 1.6 to 5.5 V)
- Sub-clock oscillator (SOSC) (32.768 kHz)
- High-speed on-chip oscillator (HOCO)
 - (24, 32, 48, 64 MHz when VCC = 2.4 to 5.5 V)
 - (24, 32, 48 MHz when VCC = 1.8 to 5.5 V)
 - (24, 32 MHz when VCC = 1.6 to 5.5 V)
- Middle-speed on-chip oscillator (MOCO) (8 MHz)
- Low-speed on-chip oscillator (LOCO) (32.768 kHz)
- IWDT-dedicated on-chip oscillator (15 kHz)
- Clock trim function for HOCO/MOCO/LOCO
- Clock out support

■ General Purpose I/O Ports

- Up to 49 input/output pins
 - Up to 3 CMOS input
 - Up to 46 CMOS input/output
 - Up to 9 input/output 5 V tolerant
 - Up to 3 high current (20 mA)

■ Operating Voltage

- VCC: 1.6 to 5.5 V

■ Operating Temperature and Packages

- Ta = -40°C to +85°C
 - 36-pin BGA (5 mm × 5 mm, 0.8 mm pitch)
- Ta = -40°C to +105°C
 - 64-pin LQFP (10 mm × 10 mm, 0.5 mm pitch)
 - 32-pin LQFP (7 mm × 7 mm, 0.8 mm pitch)
 - 48-pin QFN (7 mm × 7 mm, 0.5 mm pitch)
 - 40-pin QFN (6 mm × 6 mm, 0.5 mm pitch)

1. Overview

The MCU integrates multiple series of software- and pin-compatible Arm[®]-based 32-bit cores that share a common set of Renesas peripherals to facilitate design scalability and efficient platform-based product development.

The MCU in this series incorporates an energy-efficient Arm Cortex[®]-M23 32-bit core that is particularly well suited for cost-sensitive and low-power applications, with the following features:

- Up to 256-KB code flash memory
- 32-KB SRAM
- 16-bit A/D Converter (ADC16)
- 24-bit Sigma-Delta A/D Converter (SDADC24)
- 12-bit D/A Converter (DAC12)
- 8-bit D/A Converter (DAC8)
- Operational Amplifier (OPAMP) with configurable switches
- Security features.

1.1 Function Outline

Table 1.1 Arm core

| Feature | Functional description |
|---------------------|--|
| Arm Cortex-M23 core | <ul style="list-style-type: none"> • Maximum operating frequency: up to 48 MHz • Arm Cortex-M23 core: <ul style="list-style-type: none"> - Revision: r1p0-00rel0 - Armv8-M architecture profile - Single-cycle integer multiplier - 17-cycle integer divider. • Arm Memory Protection Unit (Arm MPU): <ul style="list-style-type: none"> - Armv8 Protected Memory System Architecture - 8 protect regions. • SysTick timer: <ul style="list-style-type: none"> - Driven by SYSTICCLK (LOCO) or ICLK. |

Table 1.2 Memory

| Feature | Functional description |
|------------------------------|--|
| Code flash memory | 256 KB of code flash memory. See section 43, Flash Memory in User's Manual. |
| Data flash memory | 8 KB of data flash memory. See section 43, Flash Memory in User's Manual. |
| Memory Mirror Function (MMF) | The Memory Mirror Function (MMF) can be configured to mirror the desired application image load address in code flash memory to the application image link address in the 23-bit unused memory space (memory mirror space addresses). Your application code is developed and linked to run from this MMF destination address. Your application code does not need to know the load location where it is stored in code flash memory. See section 5, Memory Mirror Function (MMF) in User's Manual. |
| Option-setting memory | The option-setting memory determines the state of the MCU after a reset. See section 7, Option-Setting Memory in User's Manual. |
| SRAM | On-chip high-speed SRAM with either parity bit or Error Correction Code (ECC). See section 42, SRAM in User's Manual. |

Table 1.3 System (1 of 2)

| Feature | Functional description |
|-----------------|---|
| Operating modes | Two operating modes: <ul style="list-style-type: none"> • Single-chip mode • SCI or USB boot mode. See section 3, Operating Modes in User's Manual. |

Table 1.3 System (2 of 2)

| Feature | Functional description |
|--|--|
| Resets | <p>13 resets:</p> <ul style="list-style-type: none"> • RES pin reset • Power-on reset • Independent watchdog timer reset • Watchdog timer reset • Voltage monitor 0 reset • Voltage monitor 1 reset • Voltage monitor 2 reset • SRAM parity error reset • SRAM ECC error reset • Bus master MPU error reset • Bus slave MPU error reset • CPU stack pointer error reset • Software reset. <p>See section 6, Resets in User's Manual.</p> |
| Low Voltage Detection (LVD) | <p>The Low Voltage Detection (LVD) function monitors the voltage level input to the VCC pin and the detection level can be selected using a software program. See section 8, Low Voltage Detection (LVD) in User's Manual.</p> |
| Clocks | <ul style="list-style-type: none"> • Main clock oscillator (MOSC) • Sub-clock oscillator (SOSC) • High-speed on-chip oscillator (HOCO) • Middle-speed on-chip oscillator (MOCO) • Low-speed on-chip oscillator (LOCO) • IWDG-dedicated on-chip oscillator • Clock out support. <p>See section 9, Clock Generation Circuit in User's Manual.</p> |
| Clock Frequency Accuracy Measurement Circuit (CAC) | <p>The Clock Frequency Accuracy Measurement Circuit (CAC) counts pulses of the clock to be measured (measurement target clock) within the time generated by the clock to be used as a measurement reference (measurement reference clock), and determines the accuracy depending on whether the number of pulses is within the allowable range.</p> <p>When measurement is complete or the number of pulses within the time generated by the measurement reference clock is not within the allowable range, an interrupt request is generated. See section 10, Clock Frequency Accuracy Measurement Circuit (CAC) in User's Manual.</p> |
| Interrupt Controller Unit (ICU) | <p>The Interrupt Controller Unit (ICU) controls which event signals are linked to the NVIC/DTC module. The ICU also controls NMI interrupts. See section 13, Interrupt Controller Unit (ICU) in User's Manual.</p> |
| Key Interrupt Function (KINT) | <p>A key interrupt can be generated by setting the Key Return Mode Register (KRM) and inputting a rising or falling edge to the key interrupt input pins. See section 19, Key Interrupt Function (KINT) in User's Manual.</p> |
| Low power modes | <p>Power consumption can be reduced in multiple ways, such as by setting clock dividers, stopping modules, selecting power control mode in normal operation, and transitioning to low power modes. See section 11, Low Power Modes in User's Manual.</p> |
| Register write protection | <p>The register write protection function protects important registers from being overwritten due to software errors. See section 12, Register Write Protection in User's Manual.</p> |
| Memory Protection Unit (MPU) | <p>Four Memory Protection Units (MPUs) and a CPU stack pointer monitor function are provided for memory protection. See section 15, Memory Protection Unit (MPU) in User's Manual.</p> |
| Watchdog Timer (WDT) | <p>The Watchdog Timer (WDT) is a 14-bit down-counter that can be used to reset the MCU when the counter underflows because the system has run out of control and is unable to refresh the WDT. In addition, a non-maskable interrupt or interrupt can be generated by an underflow. A refresh-permitted period can be set to refresh the counter and used as the condition to detect when the system runs out of control. See section 24, Watchdog Timer (WDT) in User's Manual.</p> |
| Independent Watchdog Timer (IWDG) | <p>The Independent Watchdog Timer (IWDG) consists of a 14-bit down-counter that must be serviced periodically to prevent counter underflow. The IWDG provides functionality to reset the MCU or to generate a non-maskable interrupt/interrupt for a timer underflow. Because the timer operates with an independent, dedicated clock source, it is particularly useful in returning the MCU to a known state as a fail-safe mechanism when the system runs out of control. The IWDG can be triggered automatically on a reset, underflow, refresh error, or by a refresh of the count value in the registers. See section 25, Independent Watchdog Timer (IWDG) in User's Manual.</p> |

Table 1.4 Event Link

| Feature | Functional description |
|-----------------------------|--|
| Event Link Controller (ELC) | The Event Link Controller (ELC) uses the interrupt requests generated by various peripheral modules as event signals to connect them to different modules, enabling direct interaction between the modules without CPU intervention. See section 17, Event Link Controller (ELC) in User's Manual. |

Table 1.5 Direct memory access

| Feature | Functional description |
|--------------------------------|--|
| Data Transfer Controller (DTC) | A Data Transfer Controller (DTC) module is provided for transferring data when activated by an interrupt request. See section 16, Data Transfer Controller (DTC) in User's Manual. |

Table 1.6 Timers

| Feature | Functional description |
|--|---|
| General PWM Timer (GPT) | The General PWM Timer (GPT) is a 32-bit timer with one channel and a 16-bit timer with six channels. PWM waveforms can be generated by controlling the up-counter, down-counter, or the up- and down-counter. In addition, PWM waveforms can be generated for controlling brushless DC motors. The GPT can also be used as a general-purpose timer. See section 21, General PWM Timer (GPT) in User's Manual. |
| Port Output Enable for GPT (POEG) | Use the Port Output Enable for GPT (POEG) function to place the General PWM Timer (GPT) output pins in the output disable state. See section 20, Port Output Enable for GPT (POEG) in User's Manual. |
| Asynchronous General Purpose Timer (AGT) | The Asynchronous General Purpose Timer (AGT) is a 16-bit timer that can be used for pulse output, external pulse width or period measurement, and counting external events. This 16-bit timer consists of a reload register and a down-counter. The reload register and the down-counter are allocated to the same address, and they can be accessed with the AGT register. See section 22, Asynchronous General Purpose Timer (AGT) in User's Manual. |
| Realtime Clock (RTC) | The Realtime Clock (RTC) has two counting modes, calendar count mode and binary count mode, that are controlled by the register settings. For calendar count mode, the RTC has a 100-year calendar from 2000 to 2099 and automatically adjusts dates for leap years. For binary count mode, the RTC counts seconds and retains the information as a serial value. Binary count mode can be used for calendars other than the Gregorian (Western) calendar. See section 23, Realtime Clock (RTC) in User's Manual. |

Table 1.7 Communication interfaces (1 of 2)

| Feature | Functional description |
|---------------------------------------|---|
| Serial Communications Interface (SCI) | The Serial Communication Interface (SCI) is configurable to five asynchronous and synchronous serial interfaces: <ul style="list-style-type: none"> Asynchronous interfaces (UART and asynchronous communications interface adapter (ACIA)) 8-bit clock synchronous interface Simple IIC (master-only) Simple SPI Smart card interface. The smart card interface complies with the ISO/IEC 7816-3 standard for electronic signals and transmission protocol. SCI0 has FIFO buffers to enable continuous and full-duplex communication, and the data transfer speed can be configured independently using an on-chip baud rate generator. See section 27, Serial Communications Interface (SCI). |
| I ² C bus interface (IIC) | The 2-channel I ² C bus interface (IIC) conforms with and provides a subset of the NXP I ² C (Inter-Integrated Circuit) bus interface functions. See section 28, I ² C Bus Interface (IIC) in User's Manual. |
| Serial Peripheral Interface (SPI) | Two independent Serial Peripheral Interface (SPI) channels are capable of high-speed, full-duplex synchronous serial communications with multiple processors and peripheral devices. See section 30, Serial Peripheral Interface (SPI). |

Table 1.7 Communication interfaces (2 of 2)

| Feature | Functional description |
|--------------------------------------|--|
| Controller Area Network (CAN) module | The Controller Area Network (CAN) module provides functionality to receive and transmit data using a message-based protocol between multiple slaves and masters in electromagnetically noisy applications. The CAN module complies with the ISO 11898-1 (CAN 2.0A/CAN 2.0B) standard and supports up to 32 mailboxes, which can be configured for transmission or reception in normal mailbox and FIFO modes. Both standard (11-bit) and extended (29-bit) messaging formats are supported. See section 29, Controller Area Network (CAN) Module in User's Manual. |
| USB 2.0 Full-Speed (USBFS) module | The USB 2.0 Full-Speed (USBFS) module can operate as a host controller or device controller. The module supports full-speed and low-speed transfer as defined in the Universal Serial Bus Specification 2.0. The module has an internal USB transceiver and supports all of the transfer types defined in the Universal Serial Bus Specification 2.0. The USB has buffer memory for data transfer, providing a maximum of five pipes. Pipe 0 and pipe 4 to pipe 7 can be assigned any endpoint number based on the peripheral devices used for communication or based on your system. The MCU supports Battery Charging Specification revision 1.2. Because the MCU can be powered at 5 V, the USB LDO regulator provides the internal USB transceiver power supply 3.3 V. See section 26, USB 2.0 Full-Speed Module (USBFS) in User's Manual. |

Table 1.8 Analog (1 of 2)

| Feature | Functional description |
|--|--|
| 16-bit A/D Converter (ADC16) | A successive approximation 16-bit A/D Converter (ADC16) is provided. Up to 17 single-ended/4 differential analog input channels are selectable. Reference voltage of SDADC24, temperature sensor output, and internal reference voltage are selectable for conversion. The calibration function calculates capacitor array DAC and gain/offset correction values under the usage conditions to enable accurate A/D conversion. See section 32, 16-Bit A/D Converter (ADC16) in User's Manual. |
| 24-bit Sigma-Delta A/D Converter (SDADC24) | A 24-bit Sigma-Delta A/D Converter (SDADC24) with a programmable gain instrumentation amplifier is provided. Up to 10 single-ended/5 differential analog input channels are selectable. The 2 single-ended/1 differential analog input channels of these analog input channels are inputs from internal OPAMP. Analog input multiplexer is input to the sigma-delta A/D converter by the programmable gain instrumentation amplifier (PGA). The A/D conversion result is filtered by the SINC3 digital filter, and then stored in an output register. The calibration function calculates gain error and offset error correction values under the usage conditions to enable accurate A/D conversion. See section 33, 24-Bit Sigma-Delta A/D Converter (SDADC24) in User's Manual. |
| 12-bit D/A Converter (DAC12) | A 12-bit D/A Converter (DAC12) is provided. See section 34, 12-Bit D/A Converter (DAC12) in User's Manual. |
| 8-bit D/A Converter (DAC8) | An 8-bit D/A Converter (DAC8) is provided. See section 35, 8-Bit D/A Converter (DAC8) in User's Manual. |
| Temperature Sensor (TSN) | The on-chip Temperature Sensor (TSN) determines and monitors the die temperature for reliable operation of the device. The sensor outputs a voltage directly proportional to the die temperature, and the relationship between the die temperature and the output voltage is linear. The output voltage is provided to the ADC16 for conversion and can be further used by the end application. See section 36, Temperature Sensor (TSN) in User's Manual. |
| High-Speed Analog Comparator (ACMPHS) | The High-Speed Analog Comparator (ACMPHS) compares a reference voltage with an analog input voltage. The comparison result can be read by software and also be output externally. The reference voltage can be selected from either an input to the IVREFi (i = 0 to 2) pin, an output from internal D/A converter, or from the internal reference voltage (Vref) generated internally in the MCU. Such flexibility is useful in applications that require go/no-go comparisons to be performed between analog signals without necessarily requiring A/D conversion. See section 38, High-Speed Analog Comparator (ACMPHS) in User's Manual. |
| Low-Power Analog Comparator (ACMPLP) | The Low-Power Analog Comparator (ACMPLP) compares a reference voltage with an analog input voltage. The comparison result can be read by software and also be output externally. The reference voltage can be selected from either an input to the CMPREFi (i = 0, 1) pin, an internal 8-bit D/A converter output, or the internal reference voltage (Vref) generated internally in the MCU. The ACMPLP response speed can be set before starting an operation. Setting high-speed mode decreases the response delay time, but increases current consumption. Setting low-speed mode increases the response delay time, but decreases current consumption. See section 39, Low-Power Analog Comparator (ACMPLP) in User's Manual. |

Table 1.8 Analog (2 of 2)

| Feature | Functional description |
|-------------------------------|--|
| Operational Amplifier (OPAMP) | The Operational Amplifier (OPAMP) can be used to amplify small analog input voltages and output the amplified voltages. A total of three differential operational amplifier units with two input pins and one output pin are provided. All units have switches that can select input signals. Additionally, operational amplifier 0 has a switch that can select the output pin. See section 37, Operational Amplifier (OPAMP) in User's Manual. |

Table 1.9 Human machine interfaces

| Feature | Functional description |
|---------------------------------------|--|
| Capacitive Touch Sensing Unit (CTSUS) | The Capacitive Touch Sensing Unit (CTSUS) measures the electrostatic capacitance of the touch sensor. Changes in the electrostatic capacitance are determined by software, which enables the CTSUS to detect whether a finger is in contact with the touch sensor. The electrode surface of the touch sensor is usually enclosed with an electrical insulator so that fingers do not come into direct contact with the electrodes. See section 40, Capacitive Touch Sensing Unit (CTSUS) in User's Manual. |

Table 1.10 Data processing

| Feature | Functional description |
|--|---|
| Cyclic Redundancy Check (CRC) calculator | The Cyclic Redundancy Check (CRC) calculator generates CRC codes to detect errors in the data. The bit order of CRC calculation results can be switched for LSB-first or MSB-first communication. Additionally, various CRC-generating polynomials are available. The snoop function allows monitoring reads from and writes to specific addresses. This function is useful in applications that require CRC code to be generated automatically in certain events, such as monitoring writes to the serial transmit buffer and reads from the serial receive buffer. See section 31, Cyclic Redundancy Check (CRC) Calculator in User's Manual. |
| Data Operation Circuit (DOC) | The Data Operation Circuit (DOC) compares, adds, and subtracts 16-bit data. See section 41, Data Operation Circuit (DOC) in User's Manual. |

Table 1.11 Security

| Feature | Functional description |
|-------------------------------------|--|
| AES | See section 44, AES Engine in User's Manual |
| True Random Number Generator (TRNG) | See section 45, True Random Number Generator (TRNG) in User's Manual |

1.2 Block Diagram

Figure 1.1 shows a block diagram of the MCU superset, some individual devices within the group have a subset of the features.

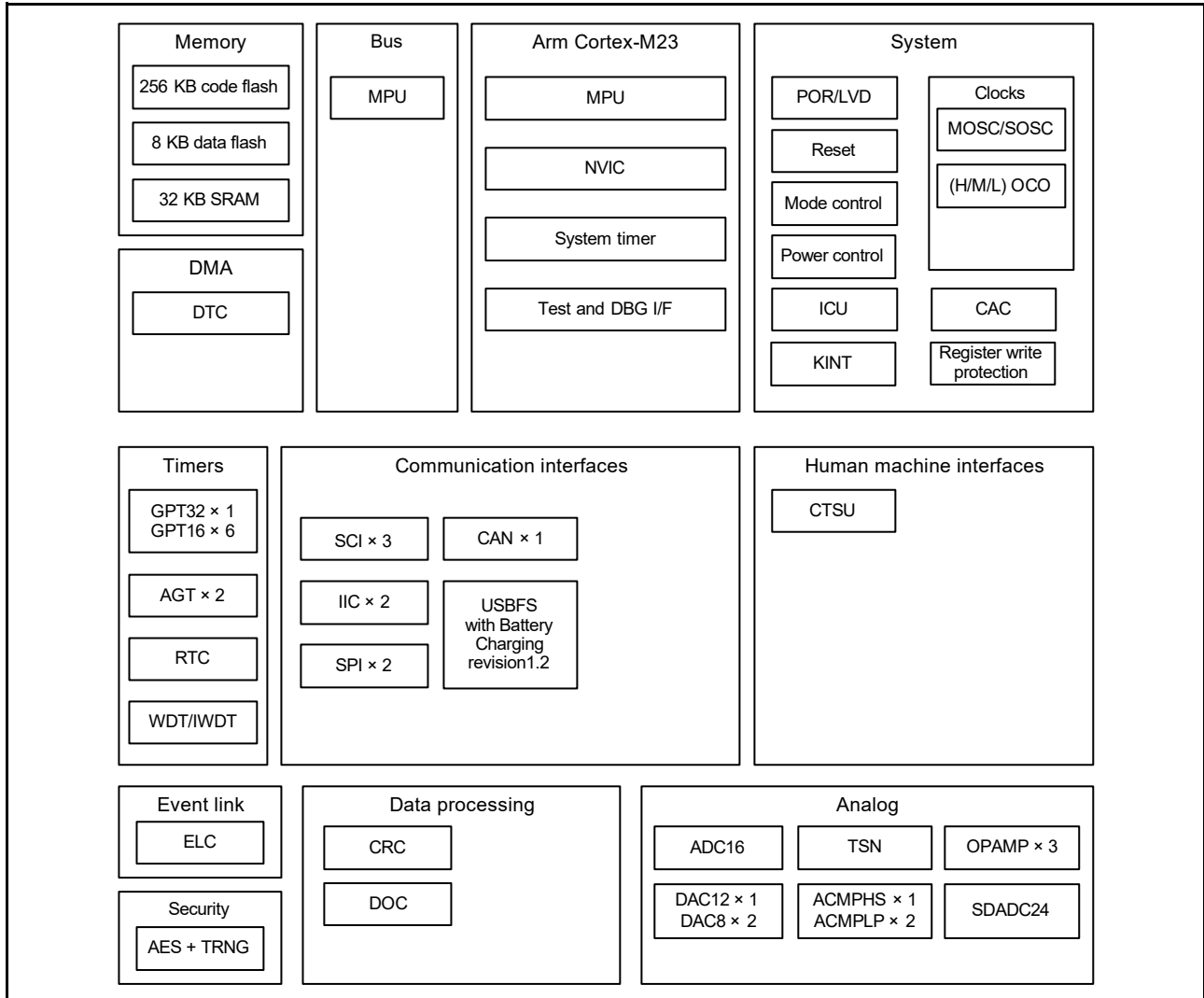

Figure 1.1 Block diagram

1.3 Part Numbering

Figure 1.2 shows the product part number information, including memory capacity and package type. Table 1.12 shows a list of products.

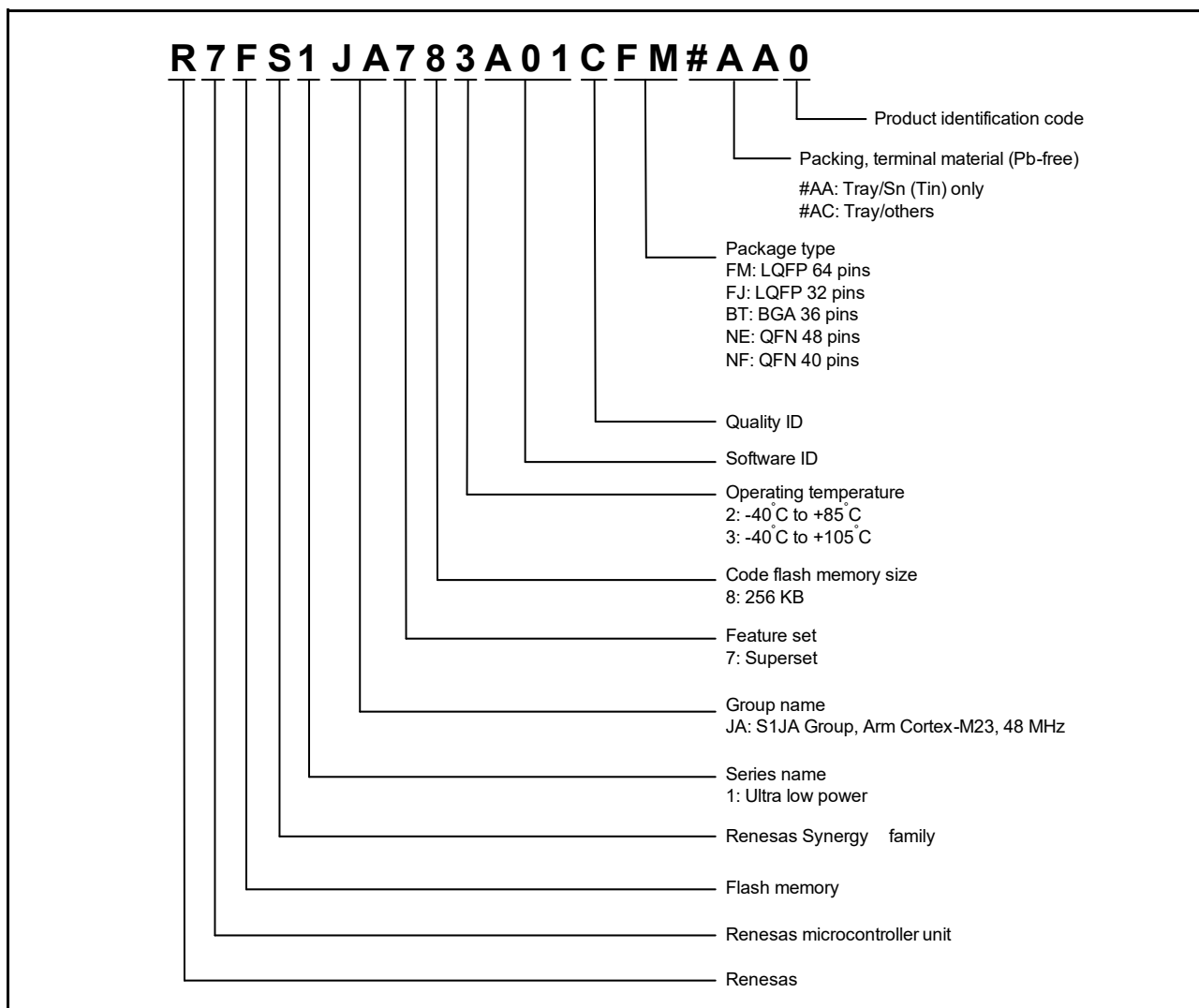

Figure 1.2 Part numbering scheme

Table 1.12 Product list

| Product part number | Orderable part number | Package code | Code flash | Data flash | SRAM | Operating temperature |
|---------------------|-----------------------|--------------|------------|------------|-------|-----------------------|
| R7FS1JA783A01CFM | R7FS1JA783A01CFM#AA0 | PLQP0064KB-C | 256 KB | 8 KB | 32 KB | -40 to +105°C |
| R7FS1JA783A01CNE | R7FS1JA783A01CNE#AC0 | PWQN0048KB-A | | | | -40 to +105°C |
| R7FS1JA783A01CNF | R7FS1JA783A01CNF#AC0 | PWQN0040KC-A | | | | -40 to +105°C |
| R7FS1JA782A01CBT | R7FS1JA782A01CBT#AC0 | PLBG0036GA-A | | | | -40 to +85°C |
| R7FS1JA783A01CFJ | R7FS1JA783A01CFJ#AA0 | PLQP0032GB-A | | | | -40 to +105°C |

1.4 Function Comparison

Table 1.13 Function comparison

| Part numbers | R7FS1JA783A01CFM | R7FS1JA783A01CNE | R7FS1JA783A01CNF | R7FS1JA782A01CBT | R7FS1JA783A01CFJ | |
|-------------------|----------------------|-----------------------|-----------------------|----------------------|----------------------|----------------------|
| Pin count | 64 | 48 | 40 | 36 | 32 | |
| Package | LQFP | QFN | QFN | BGA | LQFP | |
| Code flash memory | 256 KB | | | | | |
| Data flash memory | 8 KB | | | | | |
| SRAM | 32 KB | | | | | |
| | Parity | 16 KB | | | | |
| | ECC | 16 KB | | | | |
| System | CPU clock | 48 MHz | | | | |
| | Sub-clock oscillator | Yes | | | No | |
| | ICU | Yes | | | | |
| | KINT | 8 | 6 | 4 | 4 | 3 |
| Event control | ELC | Yes | | | | |
| DMA | DTC | Yes | | | | |
| Timers | GPT32 | 1 | | | | |
| | GPT16 | 6 | 6 | 4 | 3 | 4 |
| | AGT | 2 | | | | |
| | RTC | Yes | | | | |
| | WDT/IWDT | Yes | | | | |
| Communication | SCI | 3 | | | | |
| | IIC | 2 | | | | |
| | SPI | 2 | | 1 | 2 | |
| | CAN | Yes | | | | |
| | USBFS | Yes | | | No | |
| Analog | ADC16 | 17 (4 ^{*1}) | 12 (3 ^{*1}) | 8 (1 ^{*1}) | 5 (1 ^{*1}) | 5 (1 ^{*1}) |
| | SDADC24 | 8 (4 ^{*1}) | 6 (3 ^{*1}) | 4 (2 ^{*1}) | 2 (1 ^{*1}) | 2 (1 ^{*1}) |
| | DAC12 | 1 | | | | |
| | DAC8 | 2 | 2 ^{*2} | | 2 ^{*3} | |
| | ACMPHS | 1 | | | | |
| | ACMPLP | 2 | | | | |
| | OPAMP | 3 | 2 | 1 | 1 | 1 |
| | TSN | Yes | | | | |
| HMI | CTSU | 26 | 16 | 11 | 9 | 11 |
| Data processing | CRC | Yes | | | | |
| | DOC | Yes | | | | |
| Security | AES and TRNG | | | | | |

Note 1. The number of channels of the differential analog input.

Note 2. Pin output function of DA8_1 cannot be used.

Note 3. Pin output function of DA8_0 and DA8_1 cannot be used.

1.5 Pin Functions

Table 1.14 Pin functions (1 of 4)

| Function | Signal | I/O | Description |
|------------------------|--|--------|---|
| Power supply | VCC | Input | Power supply pin. Connect this pin to the system power supply. Connect it to VSS by a 0.1- μ F capacitor. Place the capacitor close to the pin. |
| | VCL | I/O | Connect this pin to VSS through a smoothing capacitor used to stabilize the internal power supply. Place the capacitor close to the pin. |
| | VSS | Input | Ground pin. Connect to the system power supply (0 V). |
| Clock | XTAL | Output | Pins for a crystal resonator. An external clock signal can be input through the EXTAL pin. |
| | EXTAL | Input | |
| | XCIN | Input | Input/output pins for the sub-clock oscillator. Connect a crystal resonator between XCOUT and XCIN. |
| | XCOUT | Output | |
| | CLKOUT | Output | |
| Operating mode control | MD | Input | Pins for setting the operating mode. The signal level on this pin must not be changed during operation mode transition on release from the reset state. |
| System control | RES | Input | Reset signal input pin. The MCU enters the reset state when this signal goes low. |
| CAC | CACREF | Input | Measurement reference clock input pin |
| On-chip debug | SWDIO | I/O | Serial wire debug data input/output pin |
| | SWCLK | Input | Serial wire clock pin |
| Interrupt | NMI | Input | Non-maskable interrupt request pin |
| | IRQ0 to IRQ7 | Input | Maskable interrupt request pins |
| GPT | GTETRGA, GTETRGB | Input | External trigger input pin |
| | GTIOC0A to GTIOC6A, GTIOC0B to GTIOC6B | I/O | Input capture, output compare, or PWM output pin |
| | GTIU | Input | Hall sensor input pin U |
| | GTIV | Input | Hall sensor input pin V |
| | GTIW | Input | Hall sensor input pin W |
| | GTOUUP | Output | 3-phase PWM output for BLDC motor control (positive U phase) |
| | GTOULO | Output | 3-phase PWM output for BLDC motor control (negative U phase) |
| | GTOVUP | Output | 3-phase PWM output for BLDC motor control (positive V phase) |
| | GTOVLO | Output | 3-phase PWM output for BLDC motor control (negative V phase) |
| | GTOUWP | Output | 3-phase PWM output for BLDC motor control (positive W phase) |
| | GTOWLO | Output | 3-phase PWM output for BLDC motor control (negative W phase) |
| AGT | AGTEE0, AGTEE1 | Input | External event input enable |
| | AGTIO0, AGTIO1 | I/O | External event input and pulse output |
| | AGTO0, AGTO1 | Output | Pulse output |
| | AGTOA0, AGTOA1 | Output | Output compare match A output |
| | AGTOB0, AGTOB1 | Output | Output compare match B output |
| RTC | RTCOUNT | Output | Output pin for 1-Hz/64-Hz clock |

Table 1.14 Pin functions (2 of 4)

| Function | Signal | I/O | Description |
|----------|---------------------------------|--------|---|
| SCI | SCK0, SCK1, SCK9 | I/O | Input/output pins for the clock (clock synchronous mode) |
| | RXD0, RXD1, RXD9 | Input | Input pins for received data (asynchronous mode/clock synchronous mode) |
| | TXD0, TXD1, TXD9 | Output | Output pins for transmitted data (asynchronous mode/clock synchronous mode) |
| | CTS0_RTS0, CTS1_RTS1, CTS9_RTS9 | I/O | Input/output pins for controlling the start of transmission and reception (asynchronous mode/clock synchronous mode), active-low |
| | SCL0, SCL1, SCL9 | I/O | Input/output pins for the IIC clock (simple IIC) |
| | SDA0, SDA1, SDA9 | I/O | Input/output pins for the IIC data (simple IIC) |
| | SCK0, SCK1, SCK9 | I/O | Input/output pins for the clock (simple SPI) |
| | MISO0, MISO1, MISO9 | I/O | Input/output pins for slave transmission of data (simple SPI) |
| | MOSI0, MOSI1, MOSI9 | I/O | Input/output pins for master transmission of data (simple SPI) |
| | SS0, SS1, SS9 | Input | Chip-select input pins (simple SPI), active-low |
| IIC | SCL0, SCL1 | I/O | Input/output pins for clock |
| | SDA0, SDA1 | I/O | Input/output pins for data |
| SPI | RSPCKA, RSPCKB | I/O | Clock input/output pin |
| | MOSIA, MOSIB | I/O | Inputs or outputs data output from the master |
| | MISOA, MISOB | I/O | Inputs or outputs data output from the slave |
| | SSLA0, SSLB0 | I/O | Input or output pin for slave selection |
| | SSLA1 to SSLA3, SSLB1 to SSLB3 | Output | Output pin for slave selection |
| CAN | CRX0 | Input | Receive data |
| | CTX0 | Output | Transmit data |
| USBFS | VSS_USB | Input | Ground pins |
| | VCC_USB_LDO | Input | Power supply pin for USB LDO regulator |
| | VCC_USB | I/O | Input: Power supply pin for USB transceiver. Output: USB LDO regulator output pin. This pin should be connected to an external capacitor. |
| | USB_DP | I/O | D+ I/O pin of the USB on-chip transceiver. This pin should be connected to the D+ pin of the USB bus. |
| | USB_DM | I/O | D- I/O pin of the USB on-chip transceiver. This pin should be connected to the D- pin of the USB bus. |
| | USB_VBUS | Input | USB cable connection monitor pin. This pin should be connected to VBUS of the USB bus. The VBUS pin status (connected or disconnected) can be detected when the USB module is operating as a device controller. |

Table 1.14 Pin functions (3 of 4)

| Function | Signal | I/O | Description |
|---------------------|--------------------------------|--------|--|
| Analog power supply | AVCC0 | Input | Analog voltage supply pin for the ADC16, DAC12, DAC8, ACMPHS, ACMPLP, and OPAMP |
| | AVSS0 | Input | Analog ground pin for the ADC16, DAC12, DAC8, ACMPHS, ACMPLP, and OPAMP |
| | AVCC1 | Input | Analog voltage supply pin for the SDADC24 |
| | AVSS1 | Input | Analog ground pin for the SDADC24 |
| | VREFH0 | Input | Analog reference voltage supply pin for the ADC16. Connect this pin to AVCC0 when not using the ADC16. |
| | VREFL0 | Input | Analog reference ground pin for the ADC16. Connect this pin to AVSS0 when not using the ADC16. |
| | VREFH | Input | Analog reference voltage supply pin for the DAC12 |
| | VREFL | Input | Analog reference ground pin for the DAC12 |
| ADC16 | AN000 to AN008, AN016 to AN023 | Input | Input pins for the analog signals to be processed by the A/D converter |
| | ADTRG0 | Input | Input pins for the external trigger signals that start the A/D conversion, active-low |
| SDADC24 | ANSD0P to ANSD3P | Input | Input pins for the analog signals to be processed by the SDADC24 |
| | ANSD0N to ANSD3N | Input | Input pins for the analog signals to be processed by the SDADC24 |
| | ADREG | Output | Regulator capacitance for the SDADC24 |
| | SBIAS | Output | Sensor power supply |
| | VREFI | Input | External reference voltage supply pin for the SDADC24 |
| DAC12 | DA12_0 | Output | Output pin for the analog signals to be processed by the 12-bit D/A converter |
| DAC8 | DA8_0, DA8_1 | Output | Output pins for the analog signals to be processed by the 8-bit D/A converter |
| Comparator output | VCOUT | Output | Comparator output pin |
| ACMPHS | IVREF0 to IVREF2 | Input | Reference voltage input pin |
| | IVCMP0 to IVCMP2 | Input | Analog voltage input pin |
| ACMPLP | COMPREF0, COMPREF1 | Input | Reference voltage input pins |
| | CMPIN0, CMPIN1 | Input | Analog voltage input pins |
| OPAMP | AMP0+ to AMP2+ | Input | Analog voltage input pins |
| | AMP0- to AMP2- | Input | Analog voltage input pins |
| | AMP0O to AMP2O | Output | Analog voltage output pins |
| CTSU | TS00 to TS25 | Input | Capacitive touch detection pins (touch pins) |
| | TSCAP | - | Secondary power supply pin for the touch driver |
| KINT | KR00 to KR07 | Input | Key interrupt input pins |

Table 1.14 Pin functions (4 of 4)

| Function | Signal | I/O | Description |
|------------|-----------------------------------|-----------------------------------|-----------------------------------|
| I/O ports | P000 to P003, P012 to P015 | I/O | General-purpose input/output pins |
| | P100 to P112 | I/O | General-purpose input/output pins |
| | P200 | Input | General-purpose input pin |
| | P201, P204 to P206, P212, P213 | I/O | General-purpose input/output pins |
| | P214, P215 | Input | General-purpose input pins |
| | P300 to P304 | I/O | General-purpose input/output pins |
| | P400 to P403, P407 to P411 | I/O | General-purpose input/output pins |
| | P500 to P502 | I/O | General-purpose input/output pins |
| P914, P915 | I/O | General-purpose input/output pins | |

1.6 Pin Assignments

Figure 1.3 to Figure 1.7 show the pin assignments.

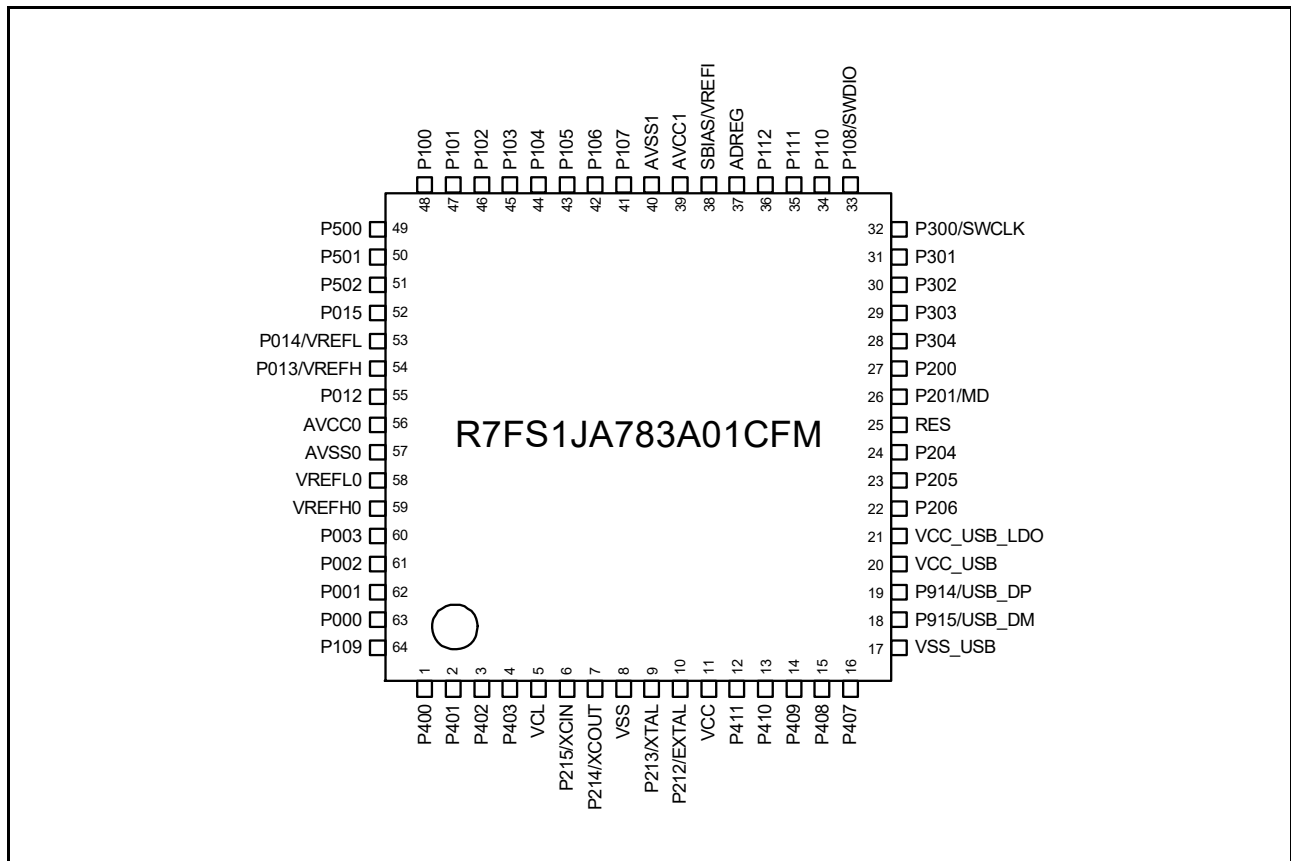

Figure 1.3 Pin assignment for LQFP 64-pin

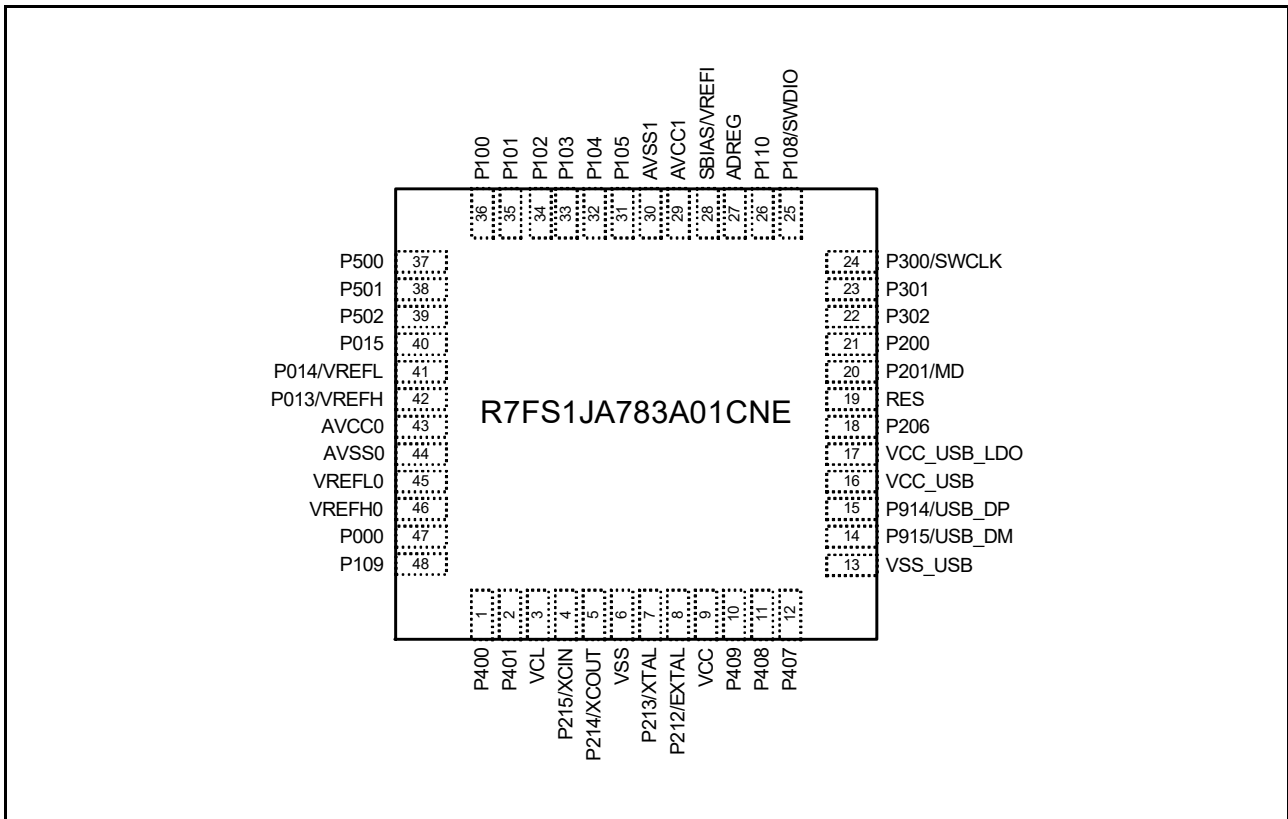

Figure 1.4 Pin assignment for QFN 48-pin

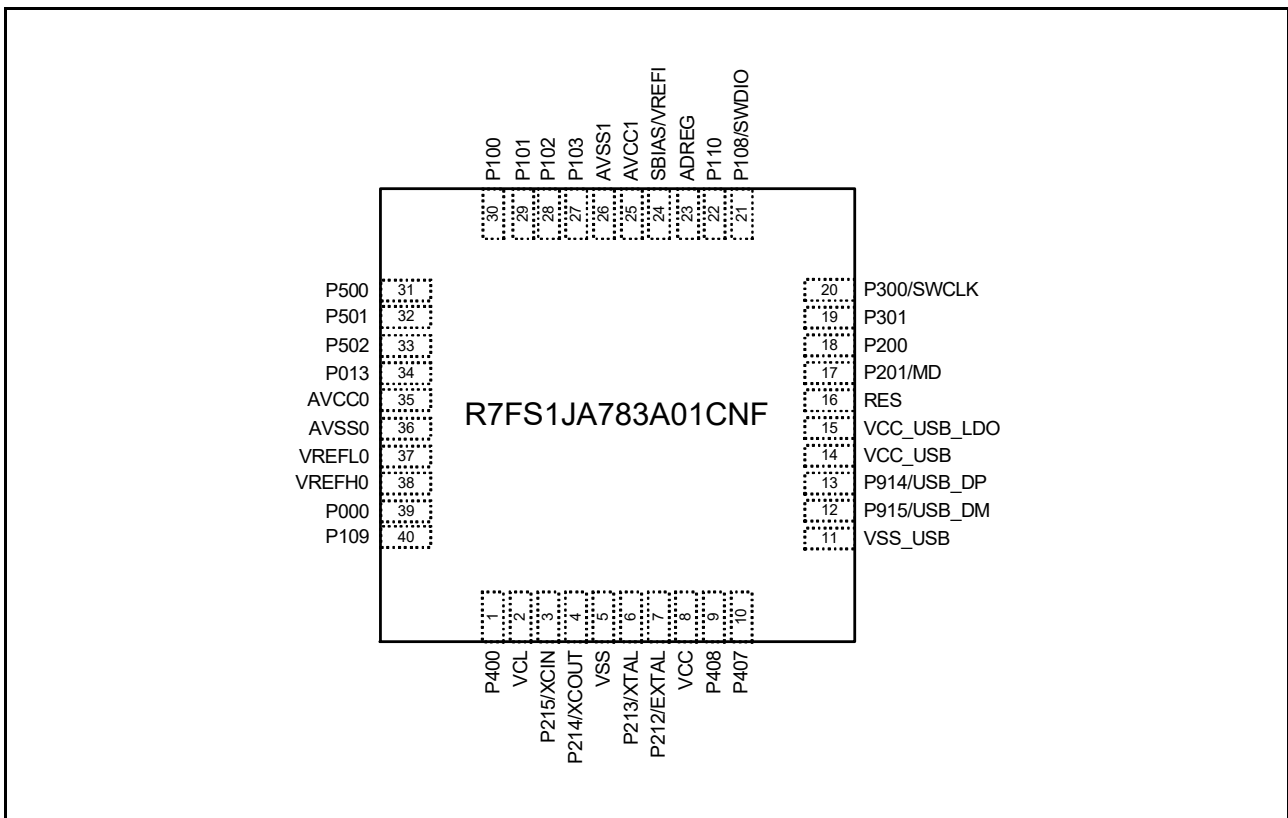

Figure 1.5 Pin assignment for QFN 40-pin

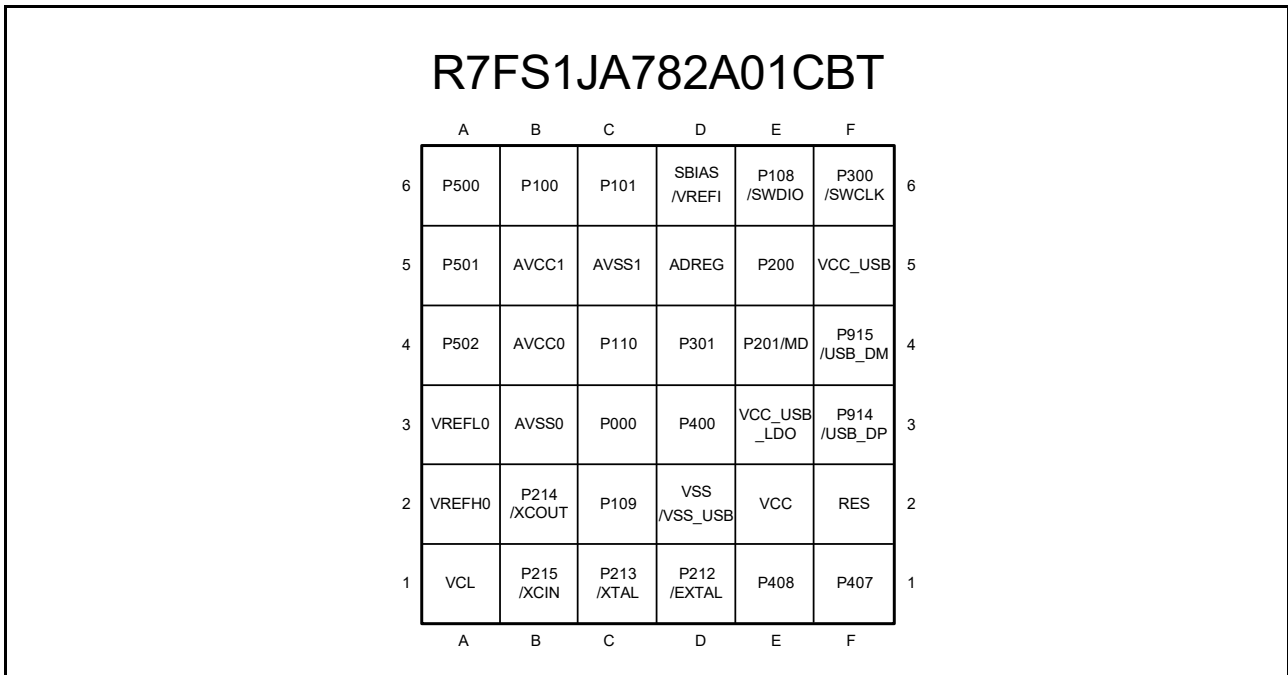

Figure 1.6 Pin assignment for BGA 36-pin (top view, pad side down)

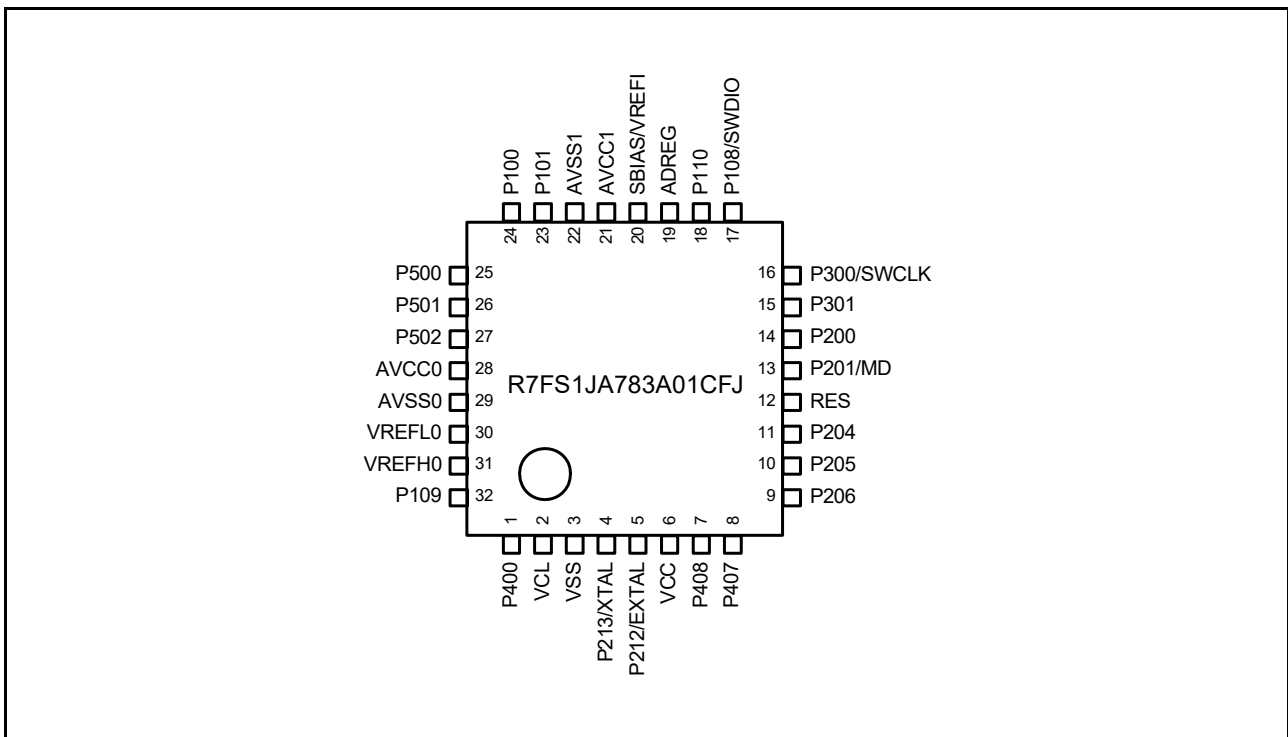

Figure 1.7 Pin assignment for LQFP 32-pin

1.7 Pin Lists

| Pin number | | | | | Power, System, Clock, Debug, CAC | I/O ports | Timers | | | | Communication Interfaces | | | | Analog | | | | HMI | |
|------------|-------|-------|-------|--------|----------------------------------|-----------|----------|---------------|----------|----------|--------------------------|-----|-----|-----|--------|---------|-------------|----------------|-------|-------------|
| LQFP64 | QFN48 | QFN40 | BGA36 | LQFP32 | | | AGT | GPT_OPS, POEG | GPT | RTC | USBFS, CAN | SCI | IIC | SPI | ADC16 | SDADC24 | DAC12, DAC8 | ACMPHS, ACMPLP | OPAMP | CTSU |
| 1 | 1 | 1 | D3 | 1 | | P400 | AGTEE0_A | GTETRA_A | GTIOC4_A | RTCOUT_C | | | | | | | | | TS00 | KR02/IRQ0_A |
| 2 | 2 | - | - | - | | P401 | AGTEE1_A | GTIU_A | GTIOC4_A | | | | | | | | | | TS01 | KR03/IRQ5_B |
| 3 | - | - | - | - | | P402 | | GTIV_A | GTIOC0_A | | | | | | | | | | TS02 | |
| 4 | - | - | - | - | | P403 | | GTIW_A | GTIOC0_B | | | | | | | | | | TS03 | |
| 5 | 3 | 2 | A1 | 2 | VCL | | | | | | | | | | | | | | | |
| 6 | 4 | 3 | B1 | - | XCIN | P215 | | | | | | | | | | | | | | |
| 7 | 5 | 4 | B2 | - | XCOU | P214 | | | | | | | | | | | | | | |
| 8 | 6 | 5 | D2 | 3 | VSS | | | | | | | | | | | | | | | |
| 9 | 7 | 6 | C1 | 4 | XTAL | P213 | AGTEE1_B | GTETRA_B | GTIOC0_A | | | | | | | | | | | IRQ2_B |
| 10 | 8 | 7 | D1 | 5 | EXTAL | P212 | AGTIO0_A | GTETRA_B | GTIOC0_B | | | | | | | | | | | IRQ3_B |
| 11 | 9 | 8 | E2 | 6 | VCC | | | | | | | | | | | | | | | |
| 12 | - | - | - | - | | P411 | | | GTIOC5_A | | | | | | | | | | | TS04 |
| 13 | - | - | - | - | | P410 | | | GTIOC5_B | | | | | | | | | | | TS05 |
| 14 | 10 | - | - | - | | P409 | AGTO1_A | | GTIOC0_A | | CTX0_B | | | | | | | | | TS06 |
| 15 | 11 | 9 | E1 | 7 | | P408 | AGTO0_A | GTOUUA | GTIOC0_A | | CRX0_B | | | | | | | | | TS07 |
| 16 | 12 | 10 | F1 | 8 | CACREF_B | P407 | AGTIO0_C | GTOUL_O | GTIOC0_B | | USB_VBUS/CTX0_D | | | | | | | | | TS08 |
| 17 | 13 | 11 | D2 | - | VSS_USB | | | | | | | | | | | | | | | |
| 18 | 14 | 12 | F4 | - | | P915 | | | | | | | | | | | | | | |
| 19 | 15 | 13 | F3 | - | | P914 | | | | | | | | | | | | | | |
| 20 | 16 | 14 | F5 | - | VCC_USB | | | | | | | | | | | | | | | |
| 21 | 17 | 15 | E3 | - | VCC_USB_LDO | | | | | | | | | | | | | | | |
| 22 | 18 | - | - | 9 | | P206 | AGTIO0_B | GTOVUA | GTIOC3_A | | | | | | | | | | | TS09 |
| 23 | - | - | - | 10 | | P205 | | GTOVL_O | GTIOC3_B | | | | | | | | | | | TS10 |
| 24 | - | - | - | 11 | | P204 | | | | | | | | | | | | | | TS11 |
| 25 | 19 | 16 | F2 | 12 | RES | | | | | | | | | | | | | | | |
| 26 | 20 | 17 | E4 | 13 | MD | P201 | | | | | | | | | | | | | | |
| 27 | 21 | 18 | E5 | 14 | | P200 | | | | | | | | | | | | | | NMI |
| 28 | - | - | - | - | | P304 | | | GTIOC6_A | | CTX0_A | | | | | | | | | TS12 |
| 29 | - | - | - | - | | P303 | | | GTIOC6_B | | CRX0_A | | | | | | | | | TS13 |
| 30 | 22 | - | - | - | CACREF_A | P302 | AGTOA1_A | GTOVL_O | GTIOC3_B | | | | | | | | | | | TS14 |

| Pin number | | | | | Power, System, Clock, Debug, CAC | I/O ports | Timers | | | | Communication Interfaces | | | | Analog | | | | HMI | | |
|------------|-------|-------|-------|--------|----------------------------------|-----------|----------|---------------|------------|----------|--------------------------|-----|--|----------|----------|----------|-------------|------------------|---------|-------------|-------------|
| LQFP64 | QFN48 | QFN40 | BGA36 | LQFP32 | | | AGT | GPT_OPS, POEG | GPT | RTC | USBFS, CAN | SCI | IIC | SPI | ADC16 | SDADC24 | DAC12, DAC8 | ACMPHS, ACMPLP | OPAMP | CTSU | Interrupt |
| 31 | 23 | 19 | D4 | 15 | | P301 | AGTOB1_A | GTOWU_P_A | GTIOC2_A_B | RTCOUT_A | | | SDA0_A | MOSIB_A | | | | | TS13 | KR04/IRQ5_A | |
| 32 | 24 | 20 | F6 | 16 | SWCLK | P300 | | | | | | | | | | | | | | | |
| 33 | 25 | 21 | E6 | 17 | SWDIO | P108 | | | | | | | | | | | | | | | |
| 34 | 26 | 22 | C4 | 18 | CLKOUT_A | P110 | AGTOB0_A | GTOWL_O_A | GTIOC2_B_B | | CTX0_C | | TXD0_D/ MOSI0_D/ SDA0_D/ RXD9_B/ MISO9_B/ SCL9_B | SDA1_D | RSPCKA_A | ADTRG0_A | | CMPREF1 | | TSCAP_A | IRQ2_A |
| 35 | - | - | - | - | | P111 | | | | RTCOUT_B | | | SCL1_C | RSPCKA_B | | | | | TS14 | IRQ6_B | |
| 36 | - | - | - | - | CLKOUT_B | P112 | | | | | | | SDA1_C | SSLA0_B | | | | | TSCAP_B | IRQ7_B | |
| 37 | 27 | 23 | D5 | 19 | ADREG | | | | | | | | | | | | | | | | |
| 38 | 28 | 24 | D6 | 20 | SBIAS/VREFI | | | | | | | | | | | | | | | | |
| 39 | 29 | 25 | B5 | 21 | AVCC1 | | | | | | | | | | | | | | | | |
| 40 | 30 | 26 | C5 | 22 | AVSS1 | | | | | | | | | | | | | | | | |
| 41 | - | - | - | - | | P107 | | | | | | | | | AN023 | ANSD3N | | | | | |
| 42 | - | - | - | - | | P106 | | | | | | | | | AN022 | ANSD3P | | | | | |
| 43 | 31 | - | - | - | | P105 | | | | | | | | MOSIB_C | AN021 | ANSD2N | | | TS18 | IRQ7_C | |
| 44 | 32 | - | - | - | | P104 | | | | | | | | MISOB_C | AN020 | ANSD2P | | | TS19 | IRQ6_C | |
| 45 | 33 | 27 | - | - | | P103 | | | GTIOC6_A_B | | | | | RSPCKB_C | AN019 | ANSD1N | | | TS20 | | |
| 46 | 34 | 28 | - | - | | P102 | | | GTIOC6_B_B | | | | CTS9_RT S9_D/ SS9_D | SSLB0_C | AN018 | ANSD1P | | | TS21 | | |
| 47 | 35 | 29 | C6 | 23 | | P101 | | | GTIOC5_A_B | | | | RXD9_C/ MISO9_C/ SCL9_C | | AN017 | ANSD0N | | IVREF2 | TS22 | IRQ5_C | |
| 48 | 36 | 30 | B6 | 24 | | P100 | | | GTIOC5_B_B | | | | TXD9_D/ MISO9_D/ SDA9_D | | AN016 | ANSD0P | | IVCMP2 | TS23 | IRQ4_C | |
| 49 | 37 | 31 | A6 | 25 | | P500 | | | GTIOC5_A_C | | | | RXD0_D/ MISO0_D/ SCL0_D | | AN000 | | DA12_0 | IVCMP0 | AMP0+ | TS24 | IRQ3_C |
| 50 | 38 | 32 | A5 | 26 | | P501 | | | GTIOC5_B_C | | | | TXD0_E/ MISO0_E/ SDA0_E | | AN001 | | | IVREF0 | AMP0- | TS25 | IRQ2_C |
| 51 | 39 | 33 | A4 | 27 | | P502 | | | | | | | CTS0_RT S0_E/ SS0_E | | AN002 | | | | AMP00 | | IRQ1_C |
| 52 | 40 | - | - | - | | P015 | | | | | | | | | AN003 | | | | AMP10 | | |
| 53 | 41 | - | - | - | VREFL | P014 | | | GTIOC6_A_C | | | | | | AN004 | | | IVREF1 | AMP1- | | |
| 54 | 42 | 34 | - | - | VREFH | P013 | | | GTIOC6_B_C | | | | | | AN005 | | DA8_0 | IVCMP1 | AMP1+ | | |
| 55 | - | - | - | - | | P012 | | | | | | | | | AN008 | | | | AMP20 | | |
| 56 | 43 | 35 | B4 | 28 | AVCC0 | | | | | | | | | | | | | | | | |
| 57 | 44 | 36 | B3 | 29 | AVSS0 | | | | | | | | | | | | | | | | |
| 58 | 45 | 37 | A3 | 30 | VREFL0 | | | | | | | | | | | | | | | | |
| 59 | 46 | 38 | A2 | 31 | VREFH0 | | | | | | | | | | | | | | | | |
| 60 | - | - | - | - | | P003 | | | | | | | | | AN006 | | | | AMP2- | | |
| 61 | - | - | - | - | | P002 | | | | | | | | | AN007 | | DA8_1 | | AMP2+ | | |
| 62 | - | - | - | - | | P001 | | | | RTCOUT_D | | | CTS9_RT S9_A/ SS9_A | | RSPCKB_D | | | | | TS15 | IRQ0_B |
| 63 | 47 | 39 | C3 | - | | P000 | AGTIO1_A | | GTIOC4_B_B | | | | RXD9_A/ MISO9_A/ SCL9_A | SCL0_C | MISOB_A | | | | | TS16 | KR00/IRQ4_A |
| 64 | 48 | 40 | C2 | 32 | | P109 | AGTOA0_A | GTETR_GB_A | GTIOC1_B_B | | | | SCK0_C/ TXD9_B/ MISO9_B/ SDA9_B | SCL1_A | MISOA_A | ADTRG0_B | | CMPREF0/ VCOUT_A | | TS17 | KR01/IRQ3_A |

Note: Several pin names have the added suffix of _A, _B, _C, _D, _E and _F. The suffix can be ignored when assigning functionality.

2. Electrical Characteristics

Unless otherwise specified, the electrical characteristics of the MCU are defined under the following conditions:

- $VCC^{*1} = AVCC0 = AVCC1 = VCC_USB^{*2} = VCC_USB_LDO^{*2} = 1.6$ to 5.5 V
- $VREFH = VREFH0 = 1.6$ to $AVCC0$
- $VSS = AVSS0 = AVSS1 = VREFL = VREFL0 = VSS_USB = 0$ V
- $T_a = T_{opr}$.

Note 1. The typical condition is set to $VCC = 3.3$ V.

Note 2. When USBFS is not used.

Figure 2.1 shows the timing conditions.

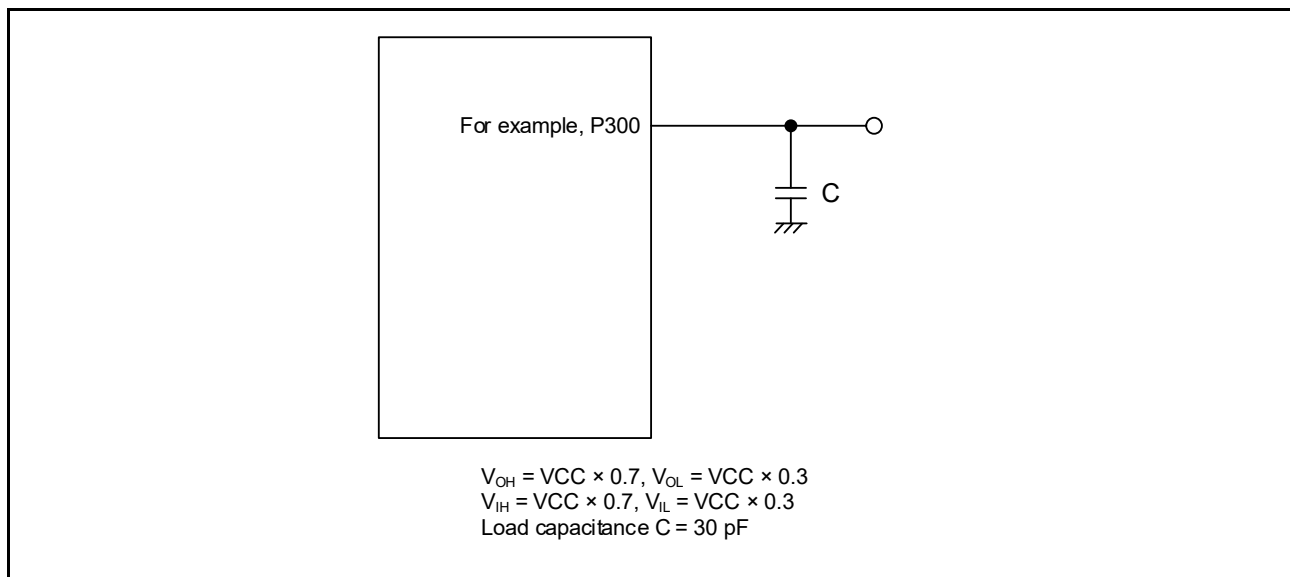

Figure 2.1 Input or output timing measurement conditions

The measurement conditions for the timing specifications of each peripheral are recommended for the best peripheral operation. However, make sure to adjust driving abilities of each pin to meet the conditions of your system.

Each function pin used for the same function must select the same drive ability. If the I/O drive ability of each function pin is mixed, the A/C specification of each function is not guaranteed.

2.1 Absolute Maximum Ratings

Table 2.1 Absolute maximum ratings (1 of 2)

| Parameter | Symbol | Value | Unit | |
|--------------------------------|--|-----------------------|-----------------------|---|
| Power supply voltage | VCC | -0.5 to +6.5 | V | |
| Input voltage | 5 V-tolerant ports*1 | V_{in} | -0.3 to +6.5 | V |
| | P002, P003, P012 to P015, P500 to P502 | V_{in} | -0.3 to $AVCC0 + 0.3$ | V |
| | P100 to P107 | V_{in} | -0.3 to $AVCC1 + 0.3$ | V |
| | Others | V_{in} | -0.3 to $VCC + 0.3$ | V |
| Reference power supply voltage | VREFH0 | -0.3 to +6.5 | V | |
| | VREFH | -0.3 to +6.5 | V | |
| | VREFI | -0.3 to $AVCC1 + 0.3$ | V | |
| Analog power supply voltage | AVCC0, AVCC1*5 | -0.5 to +6.5 | V | |

Table 2.1 Absolute maximum ratings (2 of 2)

| Parameter | Symbol | Value | Unit |
|-------------------------------|------------------|---|---------------------|
| USB power supply voltage | VCC_USB | -0.5 to +6.5 | V |
| | VCC_USB_LDO | -0.5 to +6.5 | V |
| Analog input voltage | V _{AN} | When AN000 to AN008 are used | -0.3 to AVCC0 + 0.3 |
| | | When AN016 to AN023 are used | -0.3 to AVCC1 + 0.3 |
| | | When ANSD0P to ANSD3P and ANSD0N to ANSD3N are used | -0.3 to AVCC1 + 0.3 |
| Operating temperature*2 *3 *4 | T _{opr} | -40 to +85 -40 to +105 | °C |
| Storage temperature | T _{stg} | -55 to +125 | °C |

Note 1. Ports P000, P111, P112, P205, P206, P301, P401, P407, and P409 are 5 V tolerant.

Do not input signals or an I/O pull-up power supply while the device is not powered. The current injection that results from input of such a signal or I/O pull-up might cause malfunction and the abnormal current that passes in the device at this time might cause degradation of internal elements.

Note 2. See [section 2.2.1, T_j/T_a Definition](#).

Note 3. Contact Renesas Electronics sales office for information on derating operation when T_a = +85°C to +105°C. Derating is the systematic reduction of load for improved reliability.

Note 4. The upper limit of the operating temperature is 85°C or 105°C, depending on the product. For details, see [section 1.3, Part Numbering](#).

Note 5. Use AVCC0 and AVCC1 under the same conditions:
AVCC0 = AVCC1

Caution: Permanent damage to the MCU may result if absolute maximum ratings are exceeded.

To preclude any malfunctions due to noise interference, insert capacitors with high frequency characteristics between the VCC and VSS pins, between the AVCC0 and AVSS0 pins, between the AVCC1 and AVSS1 pins, between the VCC_USB and VSS_USB pins, between the VREFH and VREFL pins, and between the VREFH0 and VREFL0 pins when VREFH0 is selected as the high potential reference voltage for the ADC16. Place capacitors of the following value as close as possible to every power supply pin and use the shortest and heaviest possible traces:

- VCC and VSS: about 0.1 μF
- AVCC0 and AVSS0: about 0.1 μF
- AVCC1 and AVSS1: about 0.1 μF
- VREFH and VREFL: about 0.1 μF
- VREFH0 and VREFL0: about 10 μF.

Also, connect capacitors as stabilization capacitance.

Connect the VCL pin to a VSS pin by a 4.7 μF capacitor. Connect the VREFH0 pin to a VREFL0 pin by 1 μF (-25% to +25%) capacitor when VREFADC is selected as the high potential reference voltage of the ADC16. Connect the ADREG pin to a AVSS1 pin by a 0.47 μF (-50% to +20%) capacitor. Connect the SBIAS/VREFI pin to a AVSS1 pin by a 0.22 μF (-20% to +20%) capacitor. Every capacitor must be placed close to the pin.

Table 2.2 Recommended operating conditions (1 of 2)

| Parameter | Symbol | Value | Min | Typ | Max | Unit |
|-----------------------|-----------|--|-------------|-----|-----|------|
| Power supply voltages | VCC*1, *2 | When USBFS is not used | 1.6 | - | 5.5 | V |
| | | When USBFS is used USB Regulator Disable | VCC_USB | - | 3.6 | V |
| | | When USBFS is used USB Regulator Enable | VCC_USB_LDO | - | 5.5 | V |
| | VSS | - | 0 | - | V | |

Table 2.2 Recommended operating conditions (2 of 2)

| Parameter | Symbol | Value | Min | Typ | Max | Unit |
|------------------------------|-------------|---|-----|-------|-------|------|
| USB power supply voltages | VCC_USB | When USBFS is not used | - | VCC | - | V |
| | | When USBFS is used USB Regulator Disable (Input) | 3.0 | 3.3 | 3.6 | V |
| | VCC_USB_LDO | When USBFS is not used | - | VCC | - | V |
| | | When USBFS is used USB Regulator Disable | - | VCC | - | V |
| | | When USBFS is used USB Regulator Enable | 3.8 | - | 5.5 | V |
| | VSS_USB | | - | 0 | - | V |
| Analog power supply voltages | AVCC0*1, *2 | | 1.6 | - | 5.5 | V |
| | AVSS0 | | - | 0 | - | V |
| | AVCC1*1, *2 | | - | AVCC0 | - | V |
| | AVSS1 | | - | 0 | - | V |
| | VREFH0 | When used as ADC16 Reference | 1.7 | - | AVCC0 | V |
| | VREFL0 | | - | 0 | - | V |
| | VREFH | When used as DAC12 Reference | 1.7 | - | AVCC0 | V |
| | VREFL | | - | 0 | - | V |
| | VREFI | When used as SDADC24 Reference*3 | 0.8 | - | 2.4 | V |

Note 1. Use AVCC0, AVCC1, and VCC under the following conditions:

AVCC0, AVCC1, and VCC can be set individually within the operating range when $VCC \geq 2.2\text{ V}$ and $AVCC0 = AVCC1 \geq 2.2\text{ V}$.
 $AVCC0 = AVCC1 = VCC$ when $VCC < 2.2\text{ V}$ or $AVCC0 = AVCC1 < 2.2\text{ V}$.

Note 2. When powering on the VCC and AVCC0 and AVCC1 pins, power them on at the same time or the VCC pin first and then the AVCC0 and AVCC1 pins.

Note 3. The condition when using external input for the reference voltage of SDADC24.

2.2 DC Characteristics

2.2.1 Tj/Ta Definition

Table 2.3 DC characteristics

Conditions: Products with operating temperature (T_a) -40 to +105°C

| Parameter | Symbol | Typ | Max | Unit | Test conditions |
|----------------------------------|--------|-----|-------|------|---|
| Permissible junction temperature | Tj | - | 125 | °C | High-speed mode Middle-speed mode Low-voltage mode Low-speed mode SubOSC-speed mode |
| | | | 105*1 | | |

Note: Make sure that $T_j = T_a + \theta_{ja} \times \text{total power consumption (W)}$, where total power consumption = $(VCC - V_{OH}) \times \Sigma I_{OH} + V_{OL} \times \Sigma I_{OL} + I_{CCmax} \times VCC$.

Note 1. The upper limit of operating temperature is 85°C or 105°C, depending on the product. For details, see [section 1.3, Part Numbering](#). If the part number shows the operation temperature at 85°C, then the maximum value of Tj is 105°C, otherwise it is 125°C.

2.2.2 I/O V_{IH} , V_{IL} **Table 2.4** I/O V_{IH} , V_{IL} Conditions: $V_{CC} = AV_{CC0} = AV_{CC1} = V_{CC_USB} = V_{CC_USB_LDO} = 1.6$ to 5.5 V

| Parameter | | Symbol | Min | Typ | Max | Unit | Test Conditions |
|---|--|--------------|--------------------------|-----|--------------------------|------|-----------------------|
| Schmitt trigger input voltage | IIC (except for SMBus)*1 | V_{IH} | $V_{CC} \times 0.7$ | - | 5.8 | V | - |
| | | V_{IL} | - | - | $V_{CC} \times 0.3$ | | |
| | | ΔV_T | $V_{CC} \times 0.05$ | - | - | | |
| | RES, NMI Other peripheral input pins excluding IIC | V_{IH} | $V_{CC} \times 0.8$ | - | - | | |
| | | V_{IL} | - | - | $V_{CC} \times 0.2$ | | |
| | | ΔV_T | $V_{CC} \times 0.1$ | - | - | | |
| Input voltage (except for Schmitt trigger input pin) | IIC (SMBus)*2 | V_{IH} | 2.2 | - | - | V | VCC = 3.6 to 5.5 V |
| | | V_{IH} | 2.0 | - | - | | VCC = 2.7 to 3.6 V |
| | | V_{IL} | - | - | 0.8 | | VCC = 2.7 to 5.5 V |
| | 5 V-tolerant ports*3 | V_{IH} | $V_{CC} \times 0.8$ | - | 5.8 | | - |
| | | V_{IL} | - | - | $V_{CC} \times 0.2$ | | |
| | P002, P003, P012 to P015, P500 to P502 | V_{IH} | $AV_{CC0} \times 0.8$ | - | - | | |
| | | V_{IL} | - | - | $AV_{CC0} \times 0.2$ | | |
| | P100 to P107 | V_{IH} | $AV_{CC1} \times 0.8$ | - | - | | |
| | | V_{IL} | - | - | $AV_{CC1} \times 0.2$ | | |
| | P914, P915 | V_{IH} | $V_{CC_USB} \times 0.8$ | - | $V_{CC_USB} + 0.3$ | | |
| | | V_{IL} | - | - | $V_{CC_USB} \times 0.2$ | | |
| | EXTAL Input ports pins except for P002, P003, P012 to P015, P100 to P107, P500 to P502, P914, P915 | V_{IH} | $V_{CC} \times 0.8$ | - | - | | |
| | | V_{IL} | - | - | $V_{CC} \times 0.2$ | | |

Note 1. SCL0_A, SCL0_B, SCL0_C, SDA0_A, SDA0_C, SCL1_B, SCL1_C, SDA1_B, SDA1_C (total 9 pins)

Note 2. SCL0_A, SCL0_B, SCL0_C, SDA0_A, SDA0_B, SDA0_C, SCL1_A, SCL1_B, SCL1_C, SDA1_A, SDA1_B, SDA1_C, SDA1_D (total 13 pins)

Note 3. P000, P111, P112, P205, P206, P301, P401, P407, P409 (total 9 pins)

2.2.3 I/O I_{OH} , I_{OL} **Table 2.5** I/O I_{OH} , I_{OL}

Conditions: VCC = AVCC0 = AVCC1 = VCC_USB = VCC_USB_LDO = 1.6 to 5.5 V

| Parameter | | Symbol | Min | Typ | Max | Unit | |
|---|---|--|----------|-----|------|-------|----|
| Permissible output current (average value per pin) | Ports P212, P213 | - | I_{OH} | - | - | -4.0 | mA |
| | | | I_{OL} | - | - | 4.0 | mA |
| | Ports P407, P408, P409 | Low drive*1 | I_{OH} | - | - | -4.0 | mA |
| | | | I_{OL} | - | - | 4.0 | mA |
| | | Middle drive for IIC Fast mode and SPI*4 | I_{OH} | - | - | -8.0 | mA |
| | | | I_{OL} | - | - | 8.0 | mA |
| | | Middle drive*2 VCC = 3.0 to 5.5 V | I_{OH} | - | - | -20.0 | mA |
| | | | I_{OL} | - | - | 20.0 | mA |
| | Ports P914, P915 | I_{OH} | - | - | -4.0 | mA | |
| | | I_{OL} | - | - | 4.0 | mA | |
| | Other output pins*3 | Low drive*1 | I_{OH} | - | - | -4.0 | mA |
| | | | I_{OL} | - | - | 4.0 | mA |
| | | Middle drive*2 | I_{OH} | - | - | -8.0 | mA |
| | | | I_{OL} | - | - | 8.0 | mA |
| Permissible output current (max value per pin) | Ports P212, P213 | - | I_{OH} | - | - | -4.0 | mA |
| | | | I_{OL} | - | - | 4.0 | mA |
| | Ports P407, P408, P409 | Low drive*1 | I_{OH} | - | - | -4.0 | mA |
| | | | I_{OL} | - | - | 4.0 | mA |
| | | Middle drive for IIC Fast mode and SPI*4 | I_{OH} | - | - | -8.0 | mA |
| | | | I_{OL} | - | - | 8.0 | mA |
| | | Middle drive*2 VCC = 3.0 to 5.5 V | I_{OH} | - | - | -20.0 | mA |
| | | | I_{OL} | - | - | 20.0 | mA |
| | Ports P914, P915 | I_{OH} | - | - | -4.0 | mA | |
| | | I_{OL} | - | - | 4.0 | mA | |
| | Other output pins*3 | Low drive*1 | I_{OH} | - | - | -4.0 | mA |
| | | | I_{OL} | - | - | 4.0 | mA |
| | | Middle drive*2 | I_{OH} | - | - | -8.0 | mA |
| | | | I_{OL} | - | - | 8.0 | mA |
| Permissible output current (max value total pins) | Total of ports P002, P003, P012 to P015, P500 to P502 | $\Sigma I_{OH}(\max)$ | - | - | -30 | mA | |
| | | $\Sigma I_{OL}(\max)$ | - | - | 30 | mA | |
| | Total of ports P100 to P107 | $\Sigma I_{OH}(\max)$ | - | - | -30 | mA | |
| | | $\Sigma I_{OL}(\max)$ | - | - | 30 | mA | |
| | Total of ports P914, P915 | ΣI_{OH} | - | - | -4.0 | mA | |
| | | ΣI_{OL} | - | - | 4.0 | mA | |
| | Total of all output pin*5 | $\Sigma I_{OH}(\max)$ | - | - | -60 | mA | |
| | | $\Sigma I_{OL}(\max)$ | - | - | 60 | mA | |

Note 1. This is the value when low driving ability is selected with the Port Drive Capability bit in the PmnPFS register.

Note 2. This is the value when middle driving ability is selected with the Port Drive Capability bit in the PmnPFS register.

Note 3. Except for Ports P200, P214, P215, which are input ports.

Note 4. This is the value when middle driving ability for IIC Fast mode and SPI is selected with the Port Drive Capability bit in PmnPFS register.

Note 5. For details on the permissible output current used with CTSU, see [section 2.12, CTSU Characteristics](#).

Caution: To protect the reliability of the MCU, the output current values should not exceed the values in [Table 2.5](#). The average output current indicates the average current value measured during 100 μ s.

2.2.4 I/O V_{OH} , V_{OL} , and Other Characteristics**Table 2.6** I/O V_{OH} , V_{OL} (1)Conditions: $V_{CC} = AV_{CC0} = AV_{CC1} = V_{CC_USB} = V_{CC_USB_LDO} = 4.0$ to 5.5 V

| Parameter | | Symbol | Min | Typ | Max | Unit | Test conditions | |
|----------------|--|--|---------------------|------------------|-----|--------------------|--------------------|--------------------|
| Output voltage | IIC*1 | V_{OL} | - | - | 0.4 | V | $I_{OL} = 3.0$ mA | |
| | | $V_{OL}^{*2,*5}$ | - | - | 0.6 | | $I_{OL} = 6.0$ mA | |
| | Ports P407, P408, P409 | Low drive | V_{OH} | $V_{CC} - 0.8$ | - | | - | $I_{OH} = -2.0$ mA |
| | | | V_{OL} | - | - | | 0.8 | $I_{OL} = 2.0$ mA |
| | | Middle drive for IIC Fast mode and SPI*5 | V_{OH} | $V_{CC} - 0.8$ | - | | - | $I_{OH} = -4.0$ mA |
| | | | V_{OL} | - | - | | 0.8 | $I_{OL} = 4.0$ mA |
| | | Middle drive*2,*3 | V_{OH} | $V_{CC} - 1.0$ | - | | - | $I_{OH} = -20$ mA |
| | | | V_{OL} | - | - | | 1.0 | $I_{OL} = 20$ mA |
| | Ports P002, P003, P012 to P015, P500 to P502 | Low drive | V_{OH} | $AV_{CC0} - 0.8$ | - | | - | $I_{OH} = -2.0$ mA |
| | | | V_{OL} | - | - | | 0.8 | $I_{OL} = 2.0$ mA |
| | | Middle drive | V_{OH} | $AV_{CC0} - 0.8$ | - | | - | $I_{OH} = -4.0$ mA |
| | | | V_{OL} | - | - | | 0.8 | $I_{OL} = 4.0$ mA |
| | Ports P100 to P107 | Low drive | V_{OH} | $AV_{CC1} - 0.8$ | - | | - | $I_{OH} = -2.0$ mA |
| | | | V_{OL} | - | - | | 0.8 | $I_{OL} = 2.0$ mA |
| | | Middle drive | V_{OH} | $AV_{CC1} - 0.8$ | - | | - | $I_{OH} = -4.0$ mA |
| | | | V_{OL} | - | - | | 0.8 | $I_{OL} = 4.0$ mA |
| | Ports P914, P915 | V_{OH} | $V_{CC_USB} - 0.8$ | - | - | | $I_{OH} = -2.0$ mA | |
| | | V_{OL} | - | - | 0.8 | | $I_{OL} = 2.0$ mA | |
| | Other output pins*4 | Low drive | V_{OH} | $V_{CC} - 0.8$ | - | | - | $I_{OH} = -2.0$ mA |
| | | | V_{OL} | - | - | | 0.8 | $I_{OL} = 2.0$ mA |
| Middle drive*6 | | V_{OH} | $V_{CC} - 0.8$ | - | - | $I_{OH} = -4.0$ mA | | |
| | | V_{OL} | - | - | 0.8 | $I_{OL} = 4.0$ mA | | |

Note 1. SCL0_A, SCL0_B, SCL0_C, SDA0_A, SDA0_B, SDA0_C, SCL1_A, SCL1_B, SCL1_C, SDA1_A, SDA1_B, SDA1_C, SDA1_D (total 13 pins).

Note 2. This is the value when middle driving ability is selected with the Port Drive Capability bit in the PmnPFS register.

Note 3. Based on characterization data, not tested in production.

Note 4. Except for P200, P214, P215, which are input ports.

Note 5. This is the value when middle driving ability for IIC and SPI is selected with the Port Drive Capability bit in PmnPFS register for P407, P408, and P409.

Note 6. Except for P212, P213.

Table 2.7 I/O V_{OH} , V_{OL} (2)Conditions: $V_{CC} = AV_{CC0} = AV_{CC1} = V_{CC_USB} = V_{CC_USB_LDO} = 2.7$ to 4.0 V

| Parameter | | Symbol | Min | Typ | Max | Unit | Test conditions | |
|----------------|--|--|---------------------|------------------|-----|--------------------|--------------------|---------------------------------------|
| Output voltage | IIC*1 | V_{OL} | - | - | 0.4 | V | $I_{OL} = 3.0$ mA | |
| | | $V_{OL}^{*2,*5}$ | - | - | 0.6 | | $I_{OL} = 6.0$ mA | |
| | Ports P407, P408, P409 | Low drive | V_{OH} | $V_{CC} - 0.5$ | - | | - | $I_{OH} = -1.0$ mA |
| | | | V_{OL} | - | - | | 0.5 | $I_{OL} = 1.0$ mA |
| | | Middle drive for IIC Fast mode and SPI*5 | V_{OH} | $V_{CC} - 0.5$ | - | | - | $I_{OH} = -2.0$ mA |
| | | | V_{OL} | - | - | | 0.5 | $I_{OL} = 2.0$ mA |
| | | Middle drive*2,*3 | V_{OH} | $V_{CC} - 1.0$ | - | | - | $I_{OH} = -20$ mA $V_{CC} = 3.3$ V |
| | | | V_{OL} | - | - | | 1.0 | $I_{OL} = 20$ mA $V_{CC} = 3.3$ V |
| | Ports P002, P003, P012 to P015, P500 to P502 | Low drive | V_{OH} | $AV_{CC0} - 0.5$ | - | | - | $I_{OH} = -1.0$ mA |
| | | | V_{OL} | - | - | | 0.5 | $I_{OL} = 1.0$ mA |
| | | Middle drive | V_{OH} | $AV_{CC0} - 0.5$ | - | | - | $I_{OH} = -2.0$ mA |
| | | | V_{OL} | - | - | | 0.5 | $I_{OL} = 2.0$ mA |
| | Ports P100 to P107 | Low drive | V_{OH} | $AV_{CC1} - 0.5$ | - | | - | $I_{OH} = -1.0$ mA |
| | | | V_{OL} | - | - | | 0.5 | $I_{OL} = 1.0$ mA |
| | | Middle drive | V_{OH} | $AV_{CC1} - 0.5$ | - | | - | $I_{OH} = -2.0$ mA |
| | | | V_{OL} | - | - | | 0.5 | $I_{OL} = 2.0$ mA |
| | Ports P914, P915 | V_{OH} | $V_{CC_USB} - 0.5$ | - | - | | $I_{OH} = -1.0$ mA | |
| | | V_{OL} | - | - | 0.5 | | $I_{OL} = 1.0$ mA | |
| | Other output pins*4 | Low drive | V_{OH} | $V_{CC} - 0.5$ | - | | - | $I_{OH} = -1.0$ mA |
| | | | V_{OL} | - | - | | 0.5 | $I_{OL} = 1.0$ mA |
| Middle drive*6 | | V_{OH} | $V_{CC} - 0.5$ | - | - | $I_{OH} = -2.0$ mA | | |
| | | V_{OL} | - | - | 0.5 | $I_{OL} = 2.0$ mA | | |

Note 1. SCL0_A, SCL0_B, SCL0_C, SDA0_A, SDA0_B, SDA0_C, SCL1_A, SCL1_B, SCL1_C, SDA1_A, SDA1_B, SDA1_C, SDA1_D (total 13 pins).

Note 2. This is the value when middle driving ability is selected with the Port Drive Capability bit in the PmnPFS register.

Note 3. Based on characterization data, not tested in production.

Note 4. Except for P200, P214, P215, which are input ports.

Note 5. This is the value when middle driving ability for IIC and SPI is selected with the Port Drive Capability bit in PmnPFS register for P407, P408, and P409.

Note 6. Except for P212, P213.

Table 2.8 I/O V_{OH} , V_{OL} (3)Conditions: $V_{CC} = AV_{CC0} = AV_{CC1} = V_{CC_USB} = V_{CC_USB_LDO} = 1.6$ to 2.7 V

| Parameter | | | Symbol | Min | Typ | Max | Unit | Test conditions |
|---------------------|--|--|----------------|---------------------|-----|--------------------|--------------------|--------------------|
| Output voltage | Ports P407, P408, P409 | Low drive | V_{OH} | $V_{CC} - 0.3$ | - | - | V | $I_{OH} = -0.5$ mA |
| | | | V_{OL} | - | - | 0.3 | | $I_{OL} = 0.5$ mA |
| | | Middle drive for IIC Fast mode and SPI*2 | V_{OH} | $V_{CC} - 0.3$ | - | - | | $I_{OH} = -1.0$ mA |
| | | | V_{OL} | - | - | 0.3 | | $I_{OL} = 1.0$ mA |
| | Ports P002, P003, P012 to P015, P500 to P502 | Low drive | V_{OH} | $AV_{CC0} - 0.3$ | - | - | $I_{OH} = -0.5$ mA | |
| | | | V_{OL} | - | - | 0.3 | $I_{OL} = 0.5$ mA | |
| | | Middle drive | V_{OH} | $AV_{CC0} - 0.3$ | - | - | $I_{OH} = -1.0$ mA | |
| | | | V_{OL} | - | - | 0.3 | $I_{OL} = 1.0$ mA | |
| | Ports P100 to P107 | Low drive | V_{OH} | $AV_{CC0} - 0.3$ | - | - | $I_{OH} = -0.5$ mA | |
| | | | V_{OL} | - | - | 0.3 | $I_{OL} = 0.5$ mA | |
| | | Middle drive | V_{OH} | $AV_{CC0} - 0.3$ | - | - | $I_{OH} = -1.0$ mA | |
| | | | V_{OL} | - | - | 0.3 | $I_{OL} = 1.0$ mA | |
| | Ports P914, P915 | | V_{OH} | $V_{CC_USB} - 0.3$ | - | - | $I_{OH} = -0.5$ mA | |
| | | | V_{OL} | - | - | 0.3 | $I_{OL} = 0.5$ mA | |
| Other output pins*1 | Low drive | V_{OH} | $V_{CC} - 0.3$ | - | - | $I_{OH} = -0.5$ mA | | |
| | | V_{OL} | - | - | 0.3 | $I_{OL} = 0.5$ mA | | |
| | Middle drive*3 | V_{OH} | $V_{CC} - 0.3$ | - | - | $I_{OH} = -1.0$ mA | | |
| | | V_{OL} | - | - | 0.3 | $I_{OL} = 1.0$ mA | | |

Note 1. Except for ports P200, P214, P215, which are input ports.

Note 2. This is the value when middle driving ability for IIC and SPI is selected with the Port Drive Capability bit in the PmnPFS register for P407, P408, and P409.

Note 3. Except for P212, P213.

Table 2.9 I/O other characteristicsConditions: $V_{CC} = AV_{CC0} = AV_{CC1} = V_{CC_USB} = V_{CC_USB_LDO} = 1.6$ to 5.5 V

| Parameter | | Symbol | Min | Typ | Max | Unit | Test conditions |
|---|---|-------------|-----|-----|-----|------------|---|
| Input leakage current | RES, ports P200, P214, P215 | $ I_{in} $ | - | - | 1.0 | μ A | $V_{in} = 0$ V $V_{in} = V_{CC}$ |
| Three-state leakage current (off state) | 5 V-tolerant ports | $ I_{TSI} $ | - | - | 1.0 | μ A | $V_{in} = 0$ V $V_{in} = 5.8$ V |
| | Other ports | | - | - | 1.0 | | |
| Input pull-up resistor | All ports (except for P200, P214, P215, P914, P915) | R_U | 10 | 20 | 50 | k Ω | $V_{in} = 0$ V |
| Input capacitance | P012 to P015, P200, P502, P914, P915 | C_{in} | - | - | 30 | μ F | $V_{in} = 0$ V $f = 1$ MHz $T_a = 25^\circ$ C |
| | Other input pins | | - | - | 15 | | |

2.2.5 Output Characteristics for I/O Pins (Low Drive Capacity)

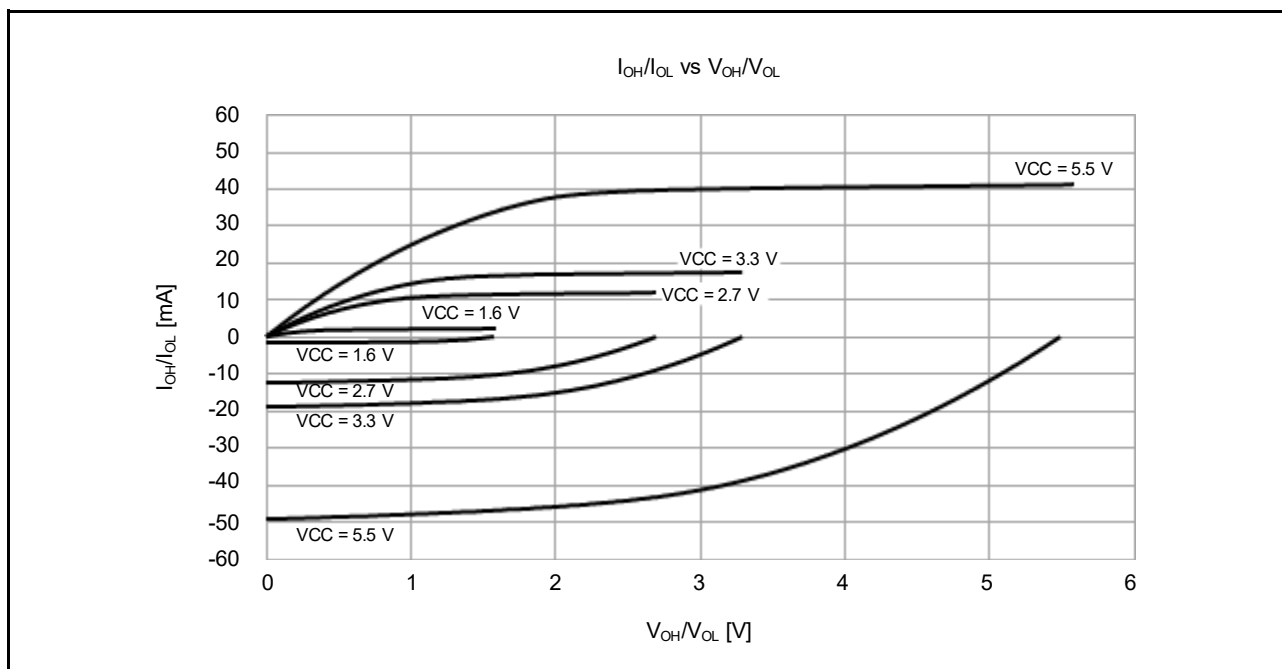

Figure 2.2 V_{OH}/V_{OL} and I_{OH}/I_{OL} voltage characteristics at $T_a = 25^\circ\text{C}$ when low drive output is selected (reference data, except for P914 and P915)

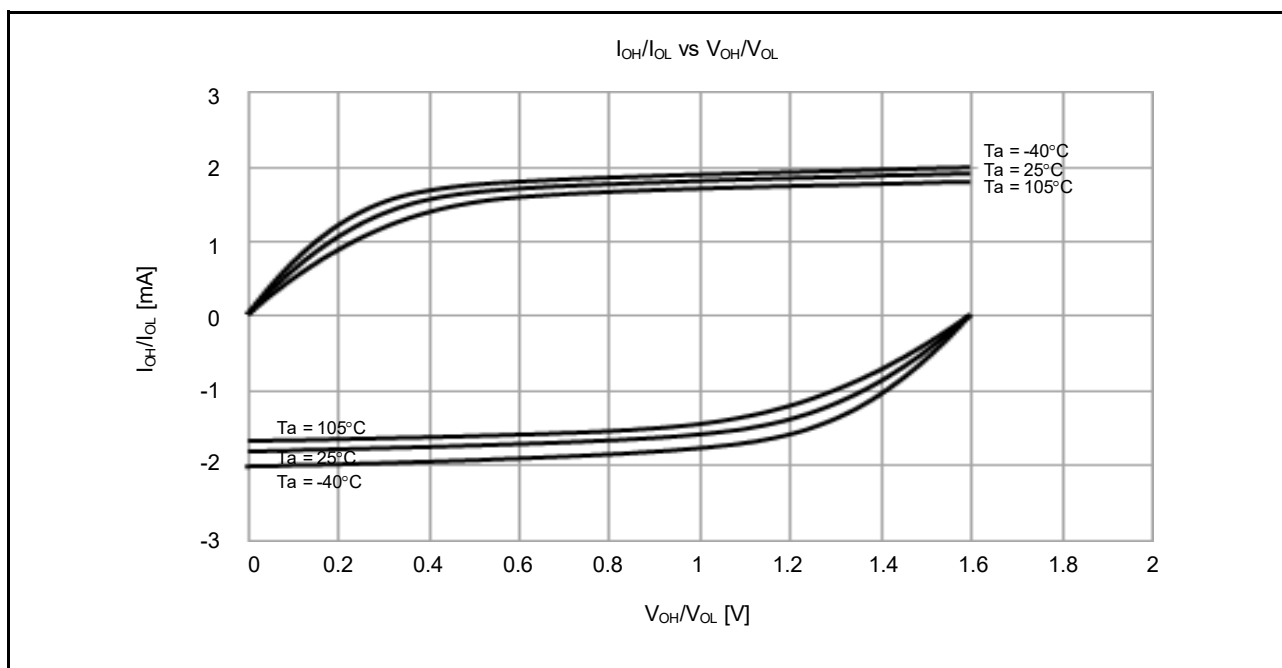

Figure 2.3 V_{OH}/V_{OL} and I_{OH}/I_{OL} temperature characteristics at $V_{CC} = 1.6$ V when low drive output is selected (reference data, except for P914 and P915)

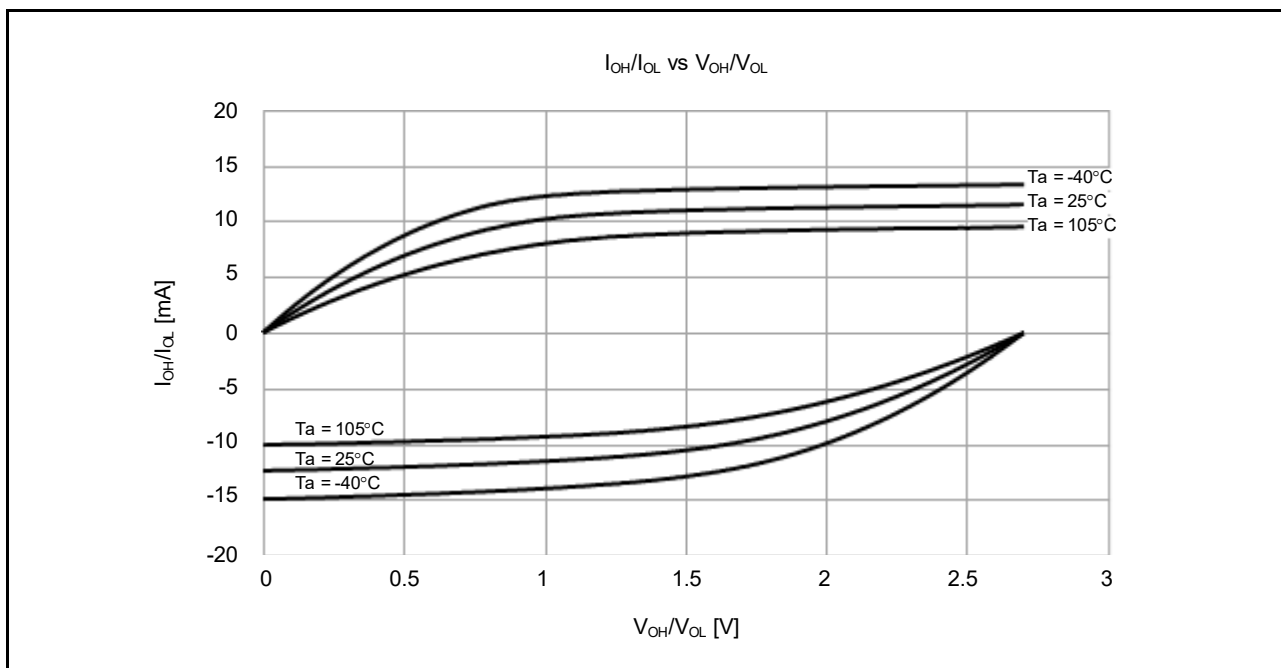

Figure 2.4 V_{OH}/V_{OL} and I_{OH}/I_{OL} temperature characteristics at $V_{CC} = 2.7$ V when low drive output is selected (reference data, except for P914 and P915)

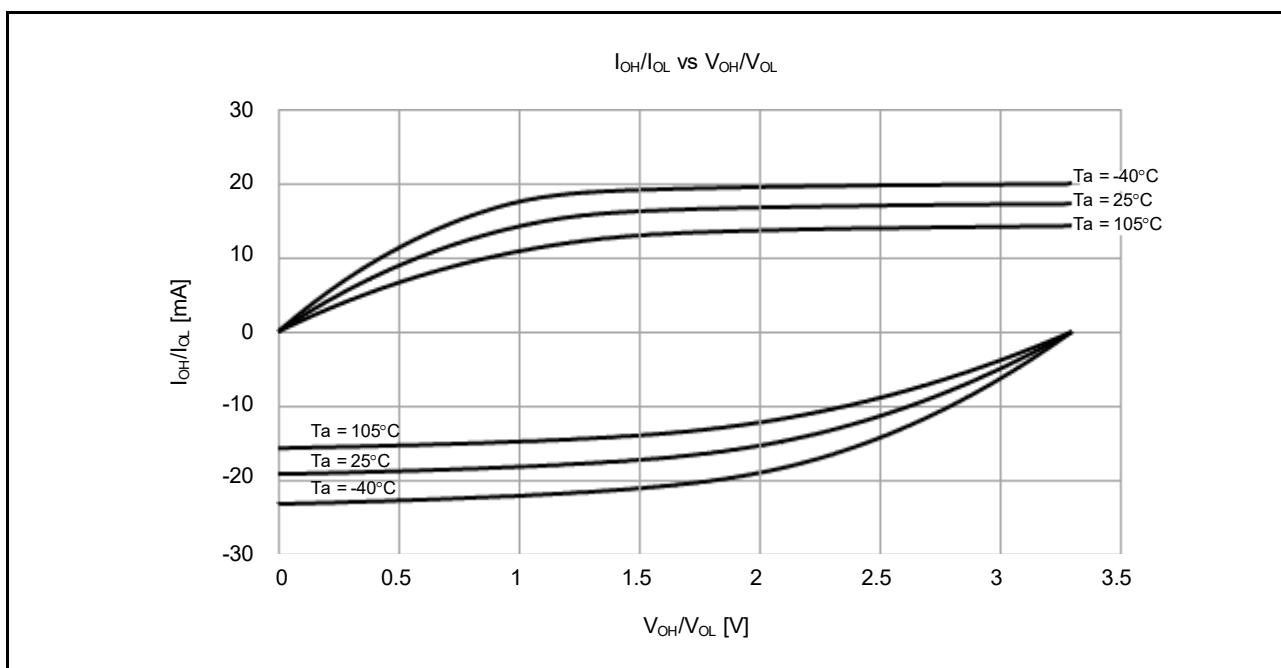

Figure 2.5 V_{OH}/V_{OL} and I_{OH}/I_{OL} temperature characteristics at $V_{CC} = 3.3$ V when low drive output is selected (reference data, except for P914 and P915)

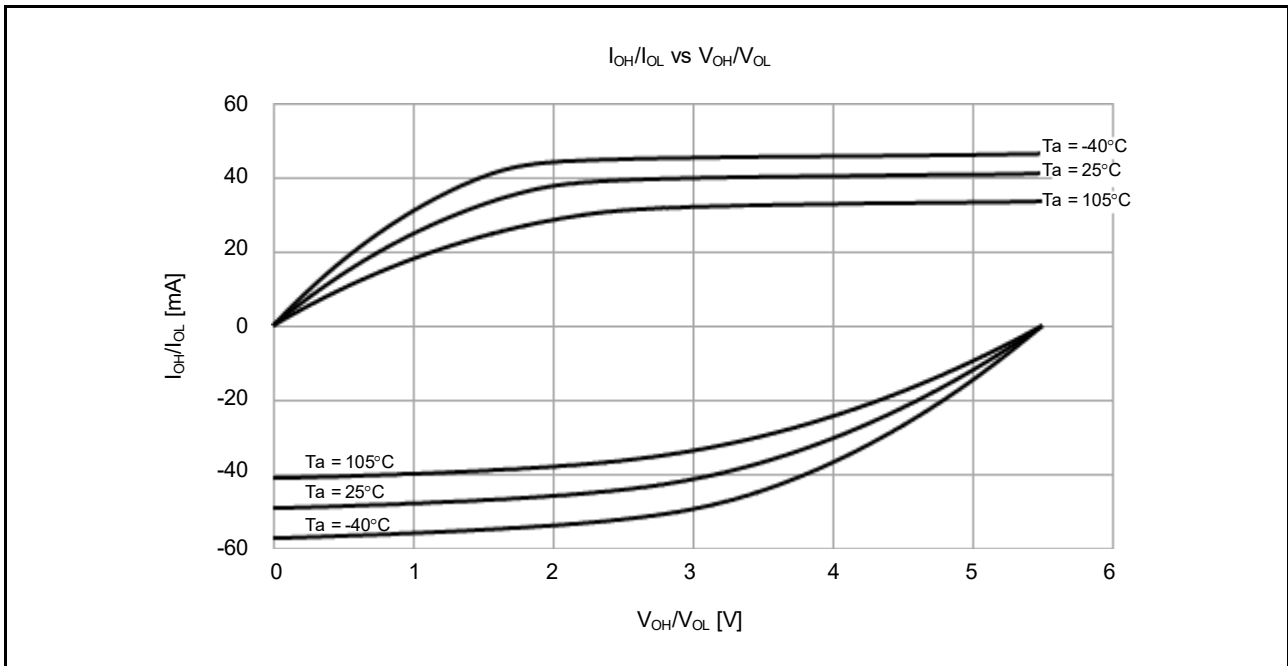

Figure 2.6 V_{OH}/V_{OL} and I_{OH}/I_{OL} temperature characteristics at $V_{CC} = 5.5\text{ V}$ when low drive output is selected (reference data, except for P914 and P915)

2.2.6 Output Characteristics for I/O Pins (Middle Drive Capacity)

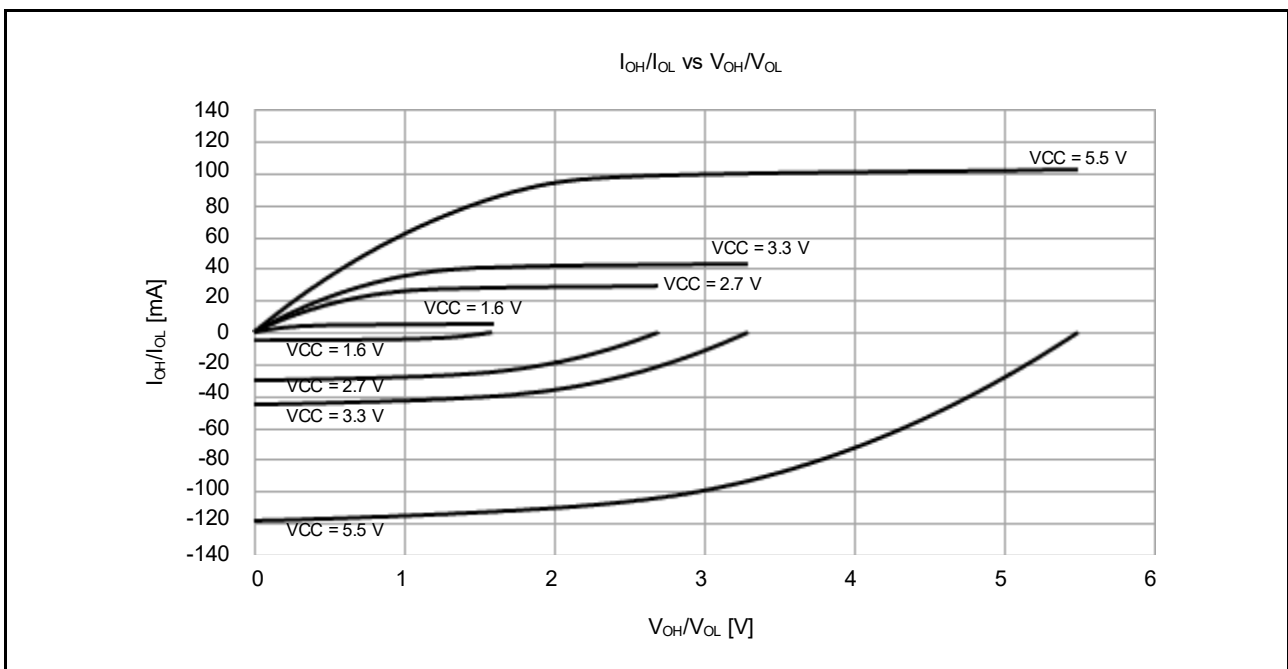

Figure 2.7 V_{OH}/V_{OL} and I_{OH}/I_{OL} voltage characteristics at $T_a = 25^\circ\text{C}$ when middle drive output is selected (reference data, except for P914 and P915)

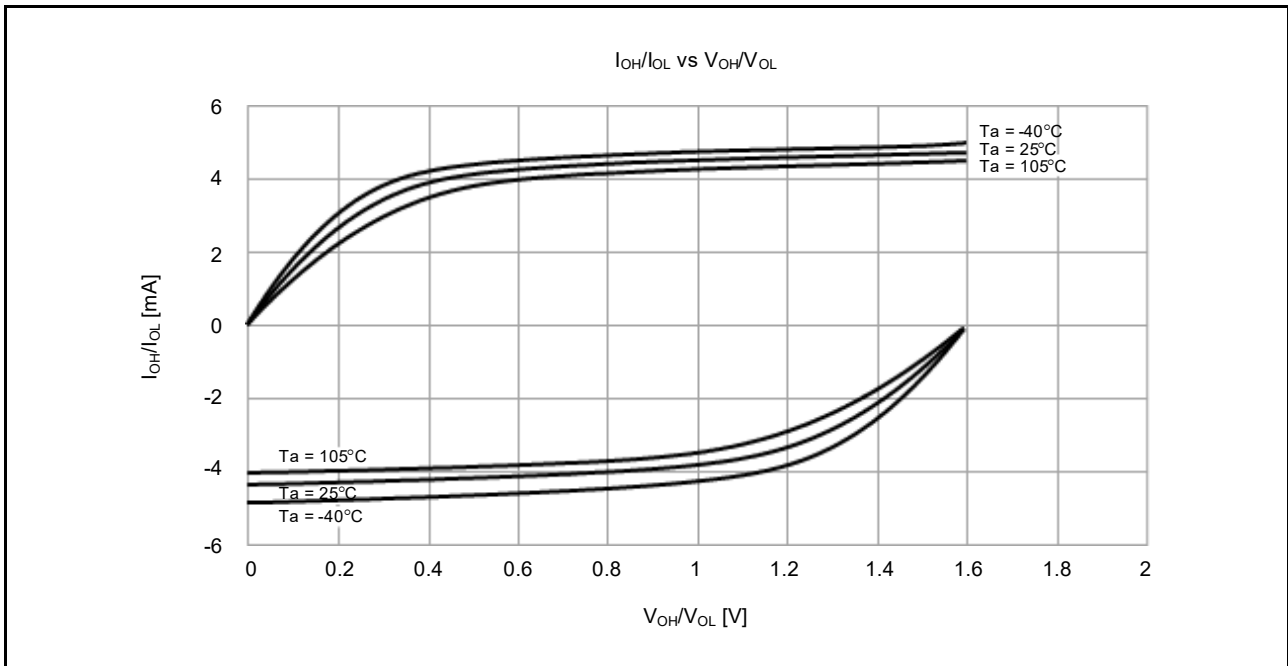

Figure 2.8 V_{OH}/V_{OL} and I_{OH}/I_{OL} temperature characteristics at $V_{CC} = 1.6$ V when middle drive output is selected (reference data, except for P914 and P915)

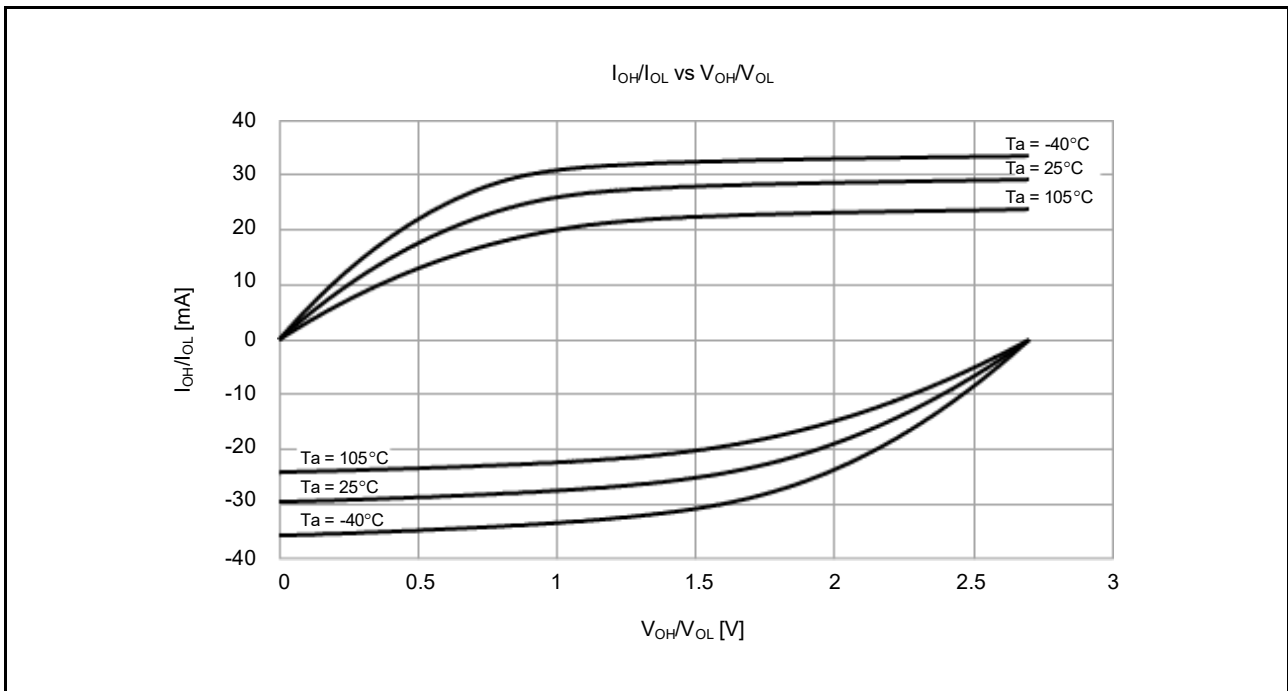

Figure 2.9 V_{OH}/V_{OL} and I_{OH}/I_{OL} temperature characteristics at $V_{CC} = 2.7$ V when middle drive output is selected (reference data, except for P914 and P915)

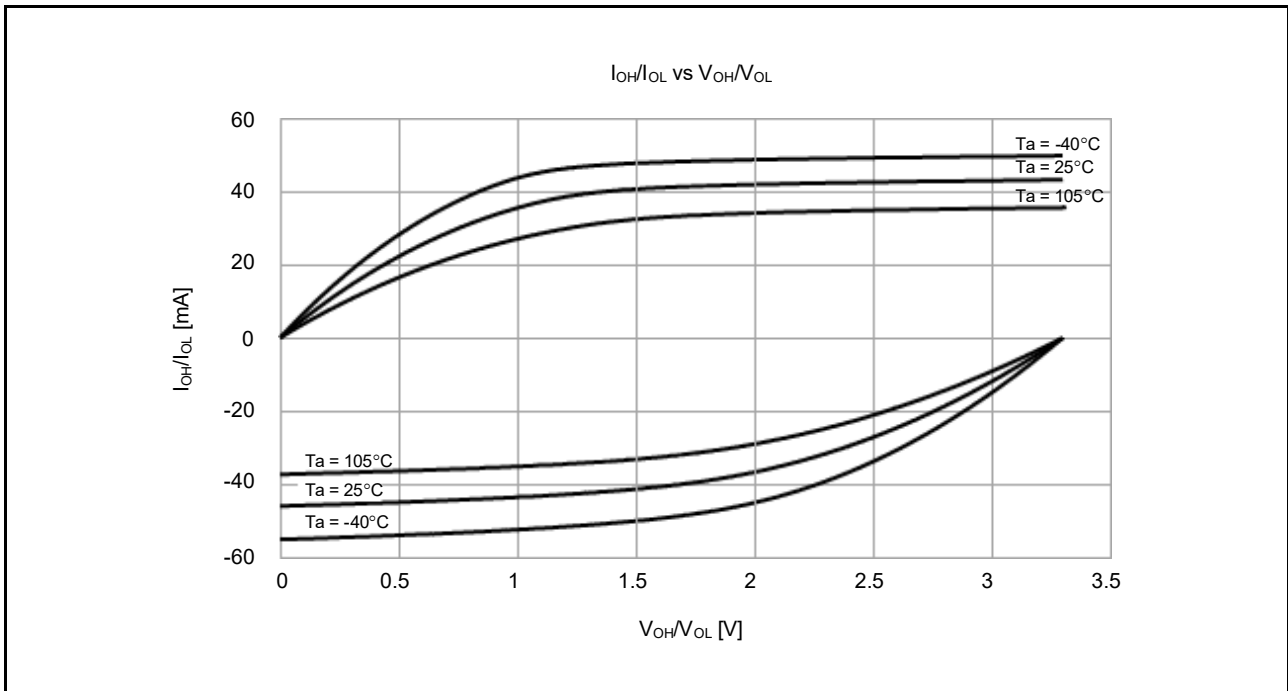

Figure 2.10 VOH/VOL and IOH/IOL temperature characteristics at VCC = 3.3 V when middle drive output is selected (reference data, except for P914 and P915)

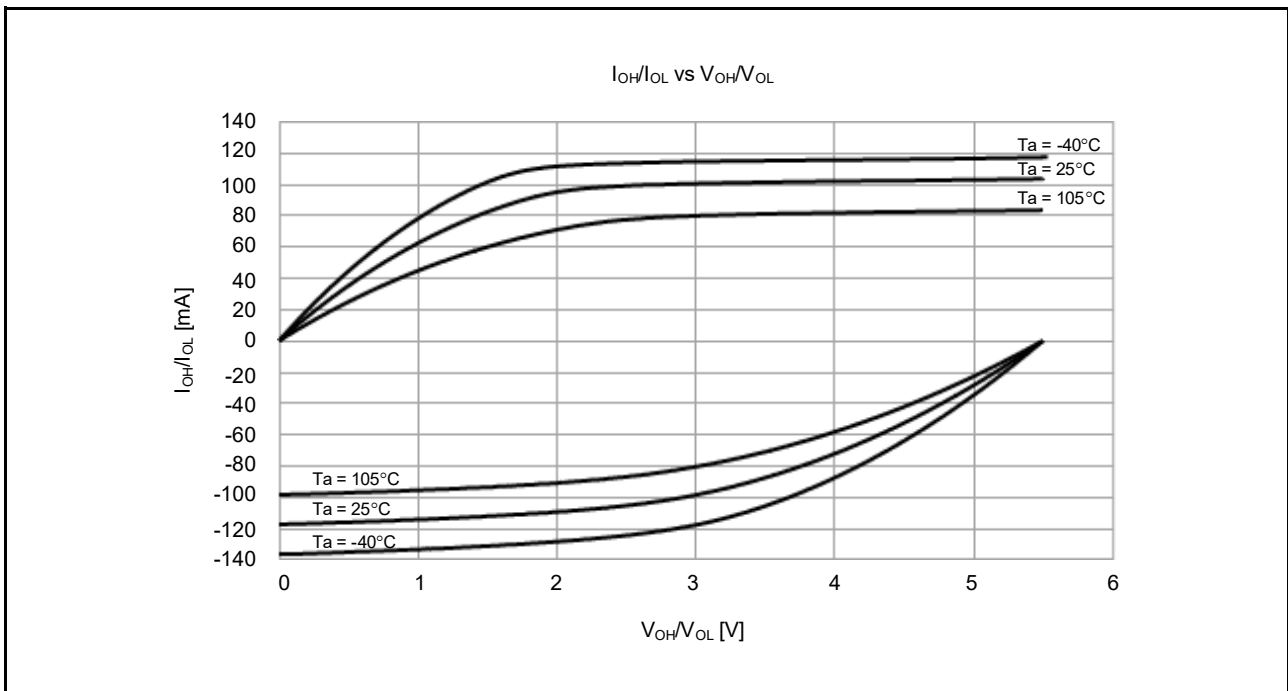

Figure 2.11 VOH/VOL and IOH/IOL temperature characteristics at VCC = 5.5 V when middle drive output is selected (reference data, except for P914 and P915)

2.2.7 Output Characteristics for P407, P408 and P409 I/O Pins (Middle Drive Capacity)

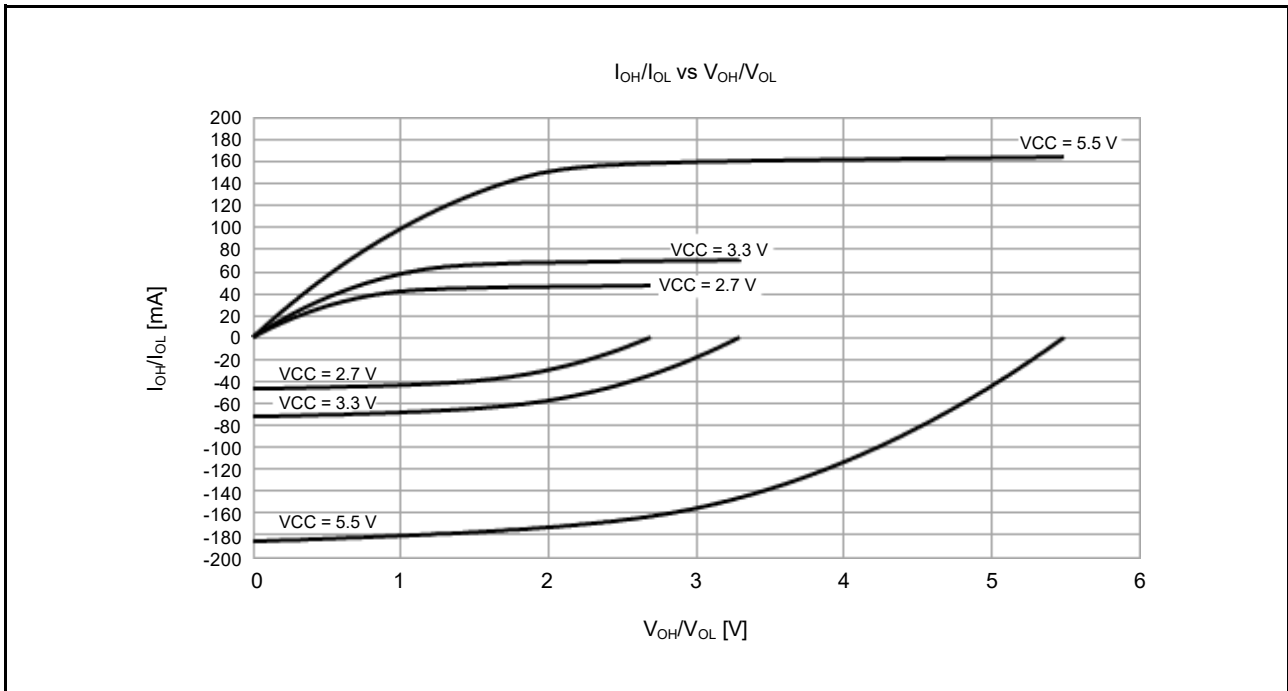

Figure 2.12 V_{OH}/V_{OL} and I_{OH}/I_{OL} voltage characteristics at $T_a = 25^\circ\text{C}$ when middle drive output is selected (reference data)

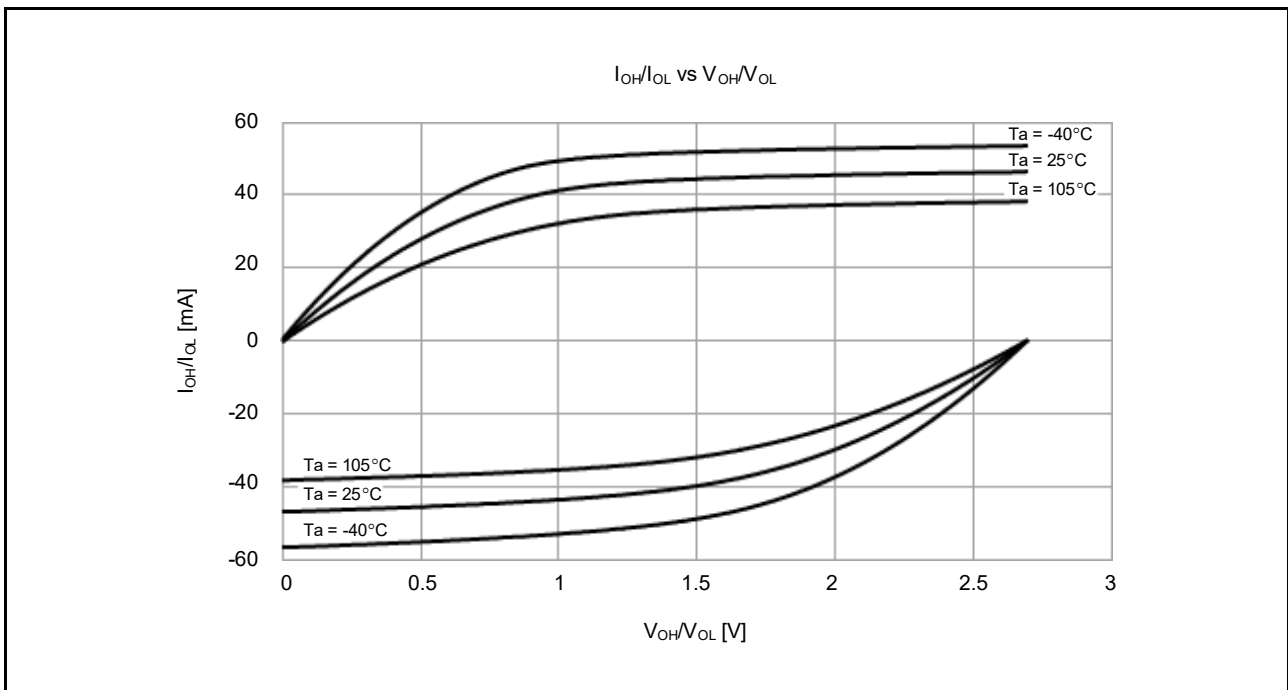

Figure 2.13 V_{OH}/V_{OL} and I_{OH}/I_{OL} temperature characteristics at $V_{CC} = 2.7\text{ V}$ when middle drive output is selected (reference data)

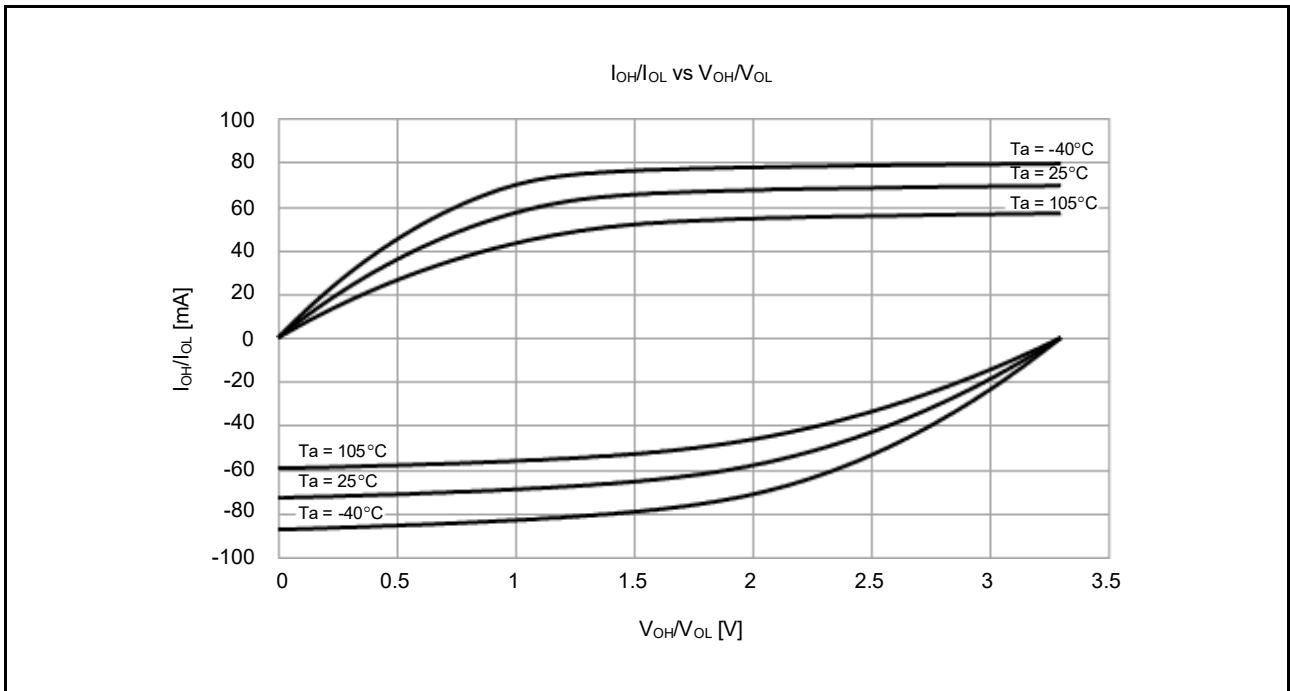

Figure 2.14 V_{OH}/V_{OL} and I_{OH}/I_{OL} temperature characteristics at $V_{CC} = 3.3$ V when middle drive output is selected (reference data)

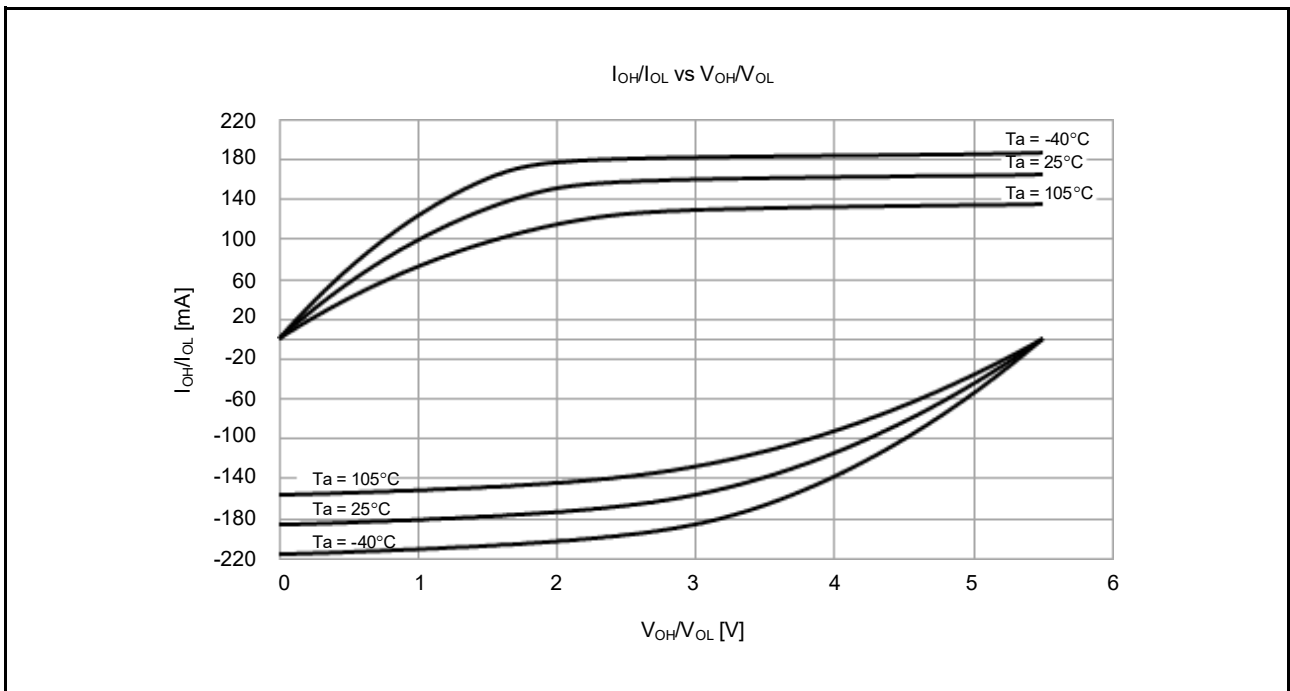

Figure 2.15 V_{OH}/V_{OL} and I_{OH}/I_{OL} temperature characteristics at $V_{CC} = 5.5$ V when middle drive output is selected (reference data)

2.2.8 Output Characteristics for IIC I/O Pins

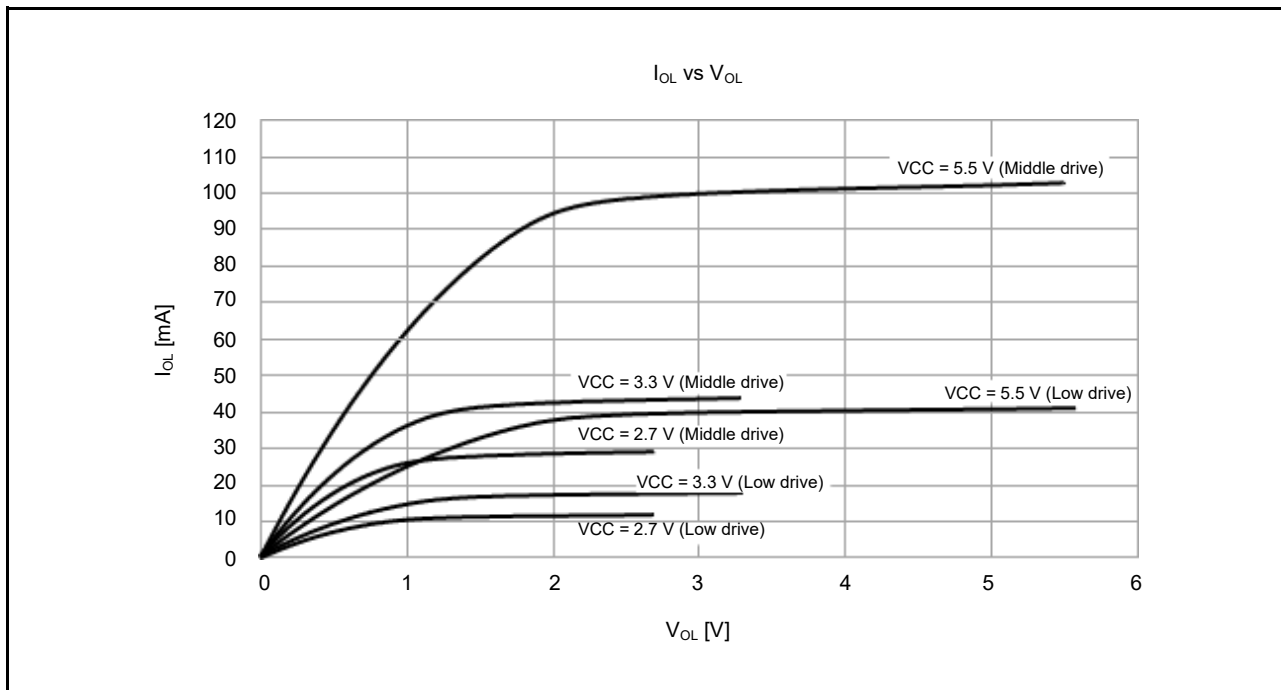

Figure 2.16 V_{OH}/V_{OL} and I_{OH}/I_{OL} voltage characteristics at $T_a = 25^\circ\text{C}$

2.2.9 Operating and Standby Current

Table 2.10 Operating and standby current (1) (1 of 2)

Conditions: VCC = AVCC0 = AVCC1 = 1.6 to 5.5 V

| Parameter | | | | Symbol | Typ*10 | Max | Unit | Test Conditions | | | | | |
|---------------------|-------------------|---|---|---------------------------------|---------------------------------|----------------------------------|---------------|-----------------|----------------------------------|---------------|-----|----|----|
| Supply current*1 | High-speed mode*2 | Normal mode | All peripheral clocks disabled, while (1) code executing from flash*5 | ICLK = 48 MHz | I _{CC} | 5.2 | - | mA | *7, *11 | | | | |
| | | | | ICLK = 32 MHz | | 3.8 | - | | | | | | |
| | | | | ICLK = 16 MHz | | 2.3 | - | | | | | | |
| | | | | ICLK = 8 MHz | | 1.6 | - | | | | | | |
| | | | All peripheral clocks disabled, CoreMark code executing from flash*5 | ICLK = 48 MHz | | 12.1 | - | | | | | | |
| | | | | ICLK = 32 MHz | | 8.3 | - | | | | | | |
| | | | | ICLK = 16 MHz | | 4.6 | - | | | | | | |
| | | | | ICLK = 8 MHz | | 2.8 | - | | | | | | |
| | | | All peripheral clocks enabled, while (1) code executing from flash*5 | ICLK = 48 MHz | | 12.6 | - | | | *9, *11 | | | |
| | | | | ICLK = 32 MHz | | 10.9 | - | | | *8, *11 | | | |
| | | | | ICLK = 16 MHz | | 5.9 | - | | | | | | |
| | | | | ICLK = 8 MHz | | 3.4 | - | | | | | | |
| | | | All peripheral clocks enabled, code executing from flash*5 | ICLK = 48 MHz | | - | 28.5 | | | *9, *11 | | | |
| | | | | Sleep mode | | All peripheral clocks disabled*5 | ICLK = 48 MHz | | | 2.7 | - | *7 | |
| | | | | | | | ICLK = 32 MHz | | | 2.1 | - | | |
| | | | | | | | ICLK = 16 MHz | | | 1.5 | - | | |
| | | | | ICLK = 8 MHz | 1.1 | | - | | | | | | |
| | | | | All peripheral clocks enabled*5 | ICLK = 48 MHz | 9.8 | - | *9 | | | | | |
| | | | | | ICLK = 32 MHz | 8.9 | - | *8 | | | | | |
| | | | | | ICLK = 16 MHz | 5.0 | - | | | | | | |
| | | ICLK = 8 MHz | 2.9 | | - | | | | | | | | |
| | | Increase during BGO operation*6 | | 2.5 | - | - | | | | | | | |
| Middle-speed mode*2 | Normal mode | All peripheral clocks disabled, while (1) code executing from flash*5 | ICLK = 12 MHz | I _{CC} | 1.6 | - | mA | *7, *11 | | | | | |
| | | | ICLK = 8 MHz | | 1.3 | - | | | | | | | |
| | | | All peripheral clocks disabled, CoreMark code executing from flash*5 | | ICLK = 12 MHz | 3.4 | | | - | | | | |
| | | | | | ICLK = 8 MHz | 2.6 | | | - | | | | |
| | | | All peripheral clocks enabled, while (1) code executing from flash*5 | | ICLK = 12 MHz | 4.3 | | | - | *8, *11 | | | |
| | | | | | ICLK = 8 MHz | 3.1 | | | - | | | | |
| | | | All peripheral clocks enabled, code executing from flash*5 | | ICLK = 12 MHz | - | | | 12.6 | | | | |
| | | | | | Sleep mode | | | | All peripheral clocks disabled*5 | ICLK = 12 MHz | 1.0 | - | *7 |
| | | | | | ICLK = 8 MHz | 0.9 | | | | - | | | |
| | | All peripheral clocks enabled*5 | ICLK = 12 MHz | | 3.6 | - | | | | *8 | | | |
| | | | ICLK = 8 MHz | | 2.7 | - | | | | | | | |
| | | | | | Increase during BGO operation*6 | | | | 2.5 | - | - | | |

Table 2.10 Operating and standby current (1) (2 of 2)

Conditions: VCC = AVCC0 = AVCC1 = 1.6 to 5.5 V

| Parameter | | | | | Symbol | Typ*10 | Max | Unit | Test Conditions |
|---------------------|--------------------|---|---|-----------------|-----------------|--------|-----|---------|-----------------|
| Supply current*1 | Low-speed mode*3 | Normal mode | All peripheral clocks disabled, while (1) code executing from flash*5 | ICLK = 1 MHz | I _{CC} | 0.3 | - | mA | *7, *11 |
| | | | All peripheral clocks disabled, CoreMark code executing from flash*5 | ICLK = 1 MHz | | 0.4 | - | | |
| | | | All peripheral clocks enabled, while (1) code executing from flash*5 | ICLK = 1 MHz | | 0.5 | - | | *8, *11 |
| | | | All peripheral clocks enabled, code executing from flash*5 | ICLK = 1 MHz | | - | 2.5 | | |
| | | Sleep mode | All peripheral clocks disabled*5 | ICLK = 1 MHz | | 0.2 | - | | *7 |
| | | | All peripheral clocks enabled*5 | ICLK = 1 MHz | | 0.4 | - | | *8 |
| | Low-voltage mode*3 | Normal mode | All peripheral clocks disabled, while (1) code executing from flash*5 | ICLK = 4 MHz | I _{CC} | 1.5 | - | mA | *7, *11 |
| | | | All peripheral clocks disabled, CoreMark code executing from flash*5 | ICLK = 4 MHz | | 2.2 | - | | |
| | | | All peripheral clocks enabled, while (1) code executing from flash*5 | ICLK = 4 MHz | | 2.5 | - | | *8, *11 |
| | | | All peripheral clocks enabled, code executing from flash*5 | ICLK = 4 MHz | | - | 7.0 | | |
| Sleep mode | | All peripheral clocks disabled*5 | ICLK = 4 MHz | 1.3 | | - | *7 | | |
| | | All peripheral clocks enabled*5 | ICLK = 4 MHz | 2.3 | | - | *8 | | |
| Subosc-speed mode*4 | Normal mode | All peripheral clocks disabled, while (1) code executing from flash*5 | ICLK = 32.768 kHz | I _{CC} | 6.5 | - | μA | *8, *11 | |
| | | All peripheral clocks enabled, while (1) code executing from flash*5 | ICLK = 32.768 kHz | | 12.1 | - | | | |
| | | All peripheral clocks enabled, code executing from flash*5 | ICLK = 32.768 kHz | | - | 190.0 | | | |
| | Sleep mode | All peripheral clocks disabled*5 | ICLK = 32.768 kHz | | 4.5 | - | | *8 | |
| | | All peripheral clocks enabled*5 | ICLK = 32.768 kHz | | 10.2 | - | | *8 | |

Note 1. Supply current values do not include output charge/discharge current from all pins. The values apply when internal pull-up MOSs are in the off state.

Note 2. The clock source is HOCO.

Note 3. The clock source is MOCO.

Note 4. The clock source is the sub-clock oscillator.

Note 5. This does not include BGO operation.

Note 6. This is the increase for programming or erasure of the flash memory for data storage during program execution.

Note 7. FCLK, PCLKB, and PCLKD are set to divided by 64.

Note 8. FCLK, PCLKB, and PCLKD are the same frequency as that of ICLK.

Note 9. FCLK and PCLKB are set to be divided by 2 and PCLKD is the same frequency as that of ICLK.

Note 10. VCC = 3.3 V.

Note 11. The flash cache is operating.

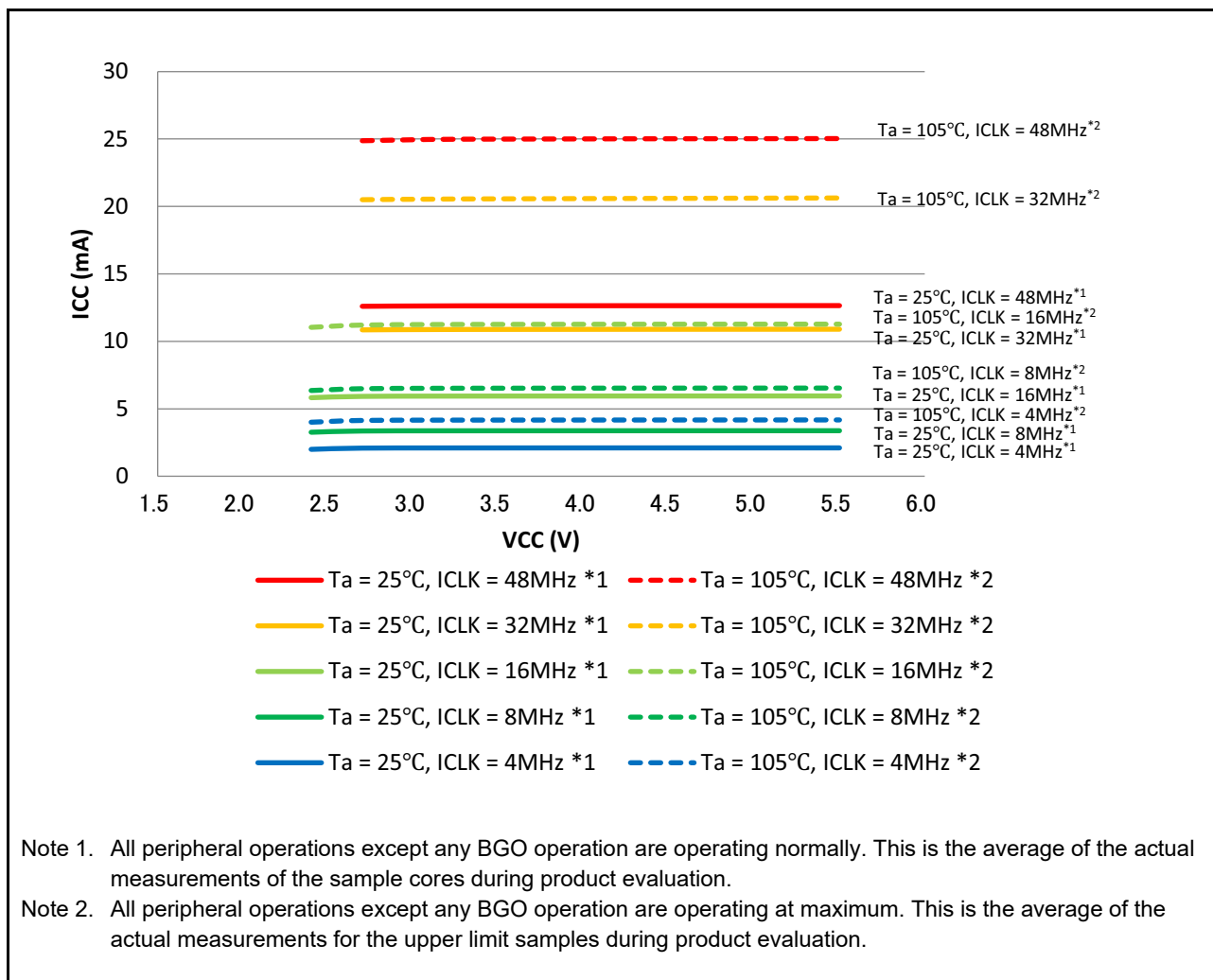

Figure 2.17 Voltage dependency in high-speed operating mode (reference data)

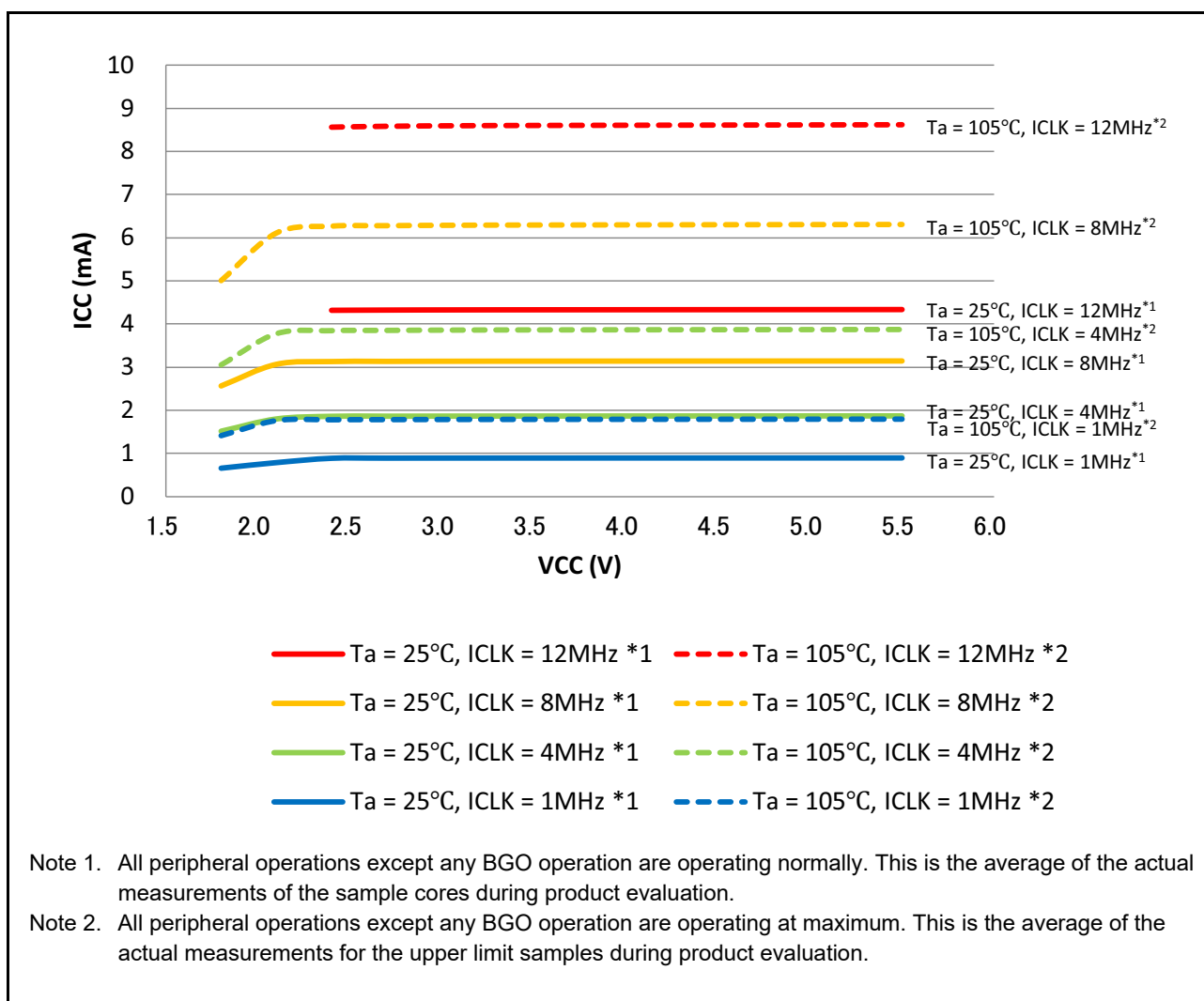

Figure 2.18 Voltage dependency in middle-speed operating mode (reference data)

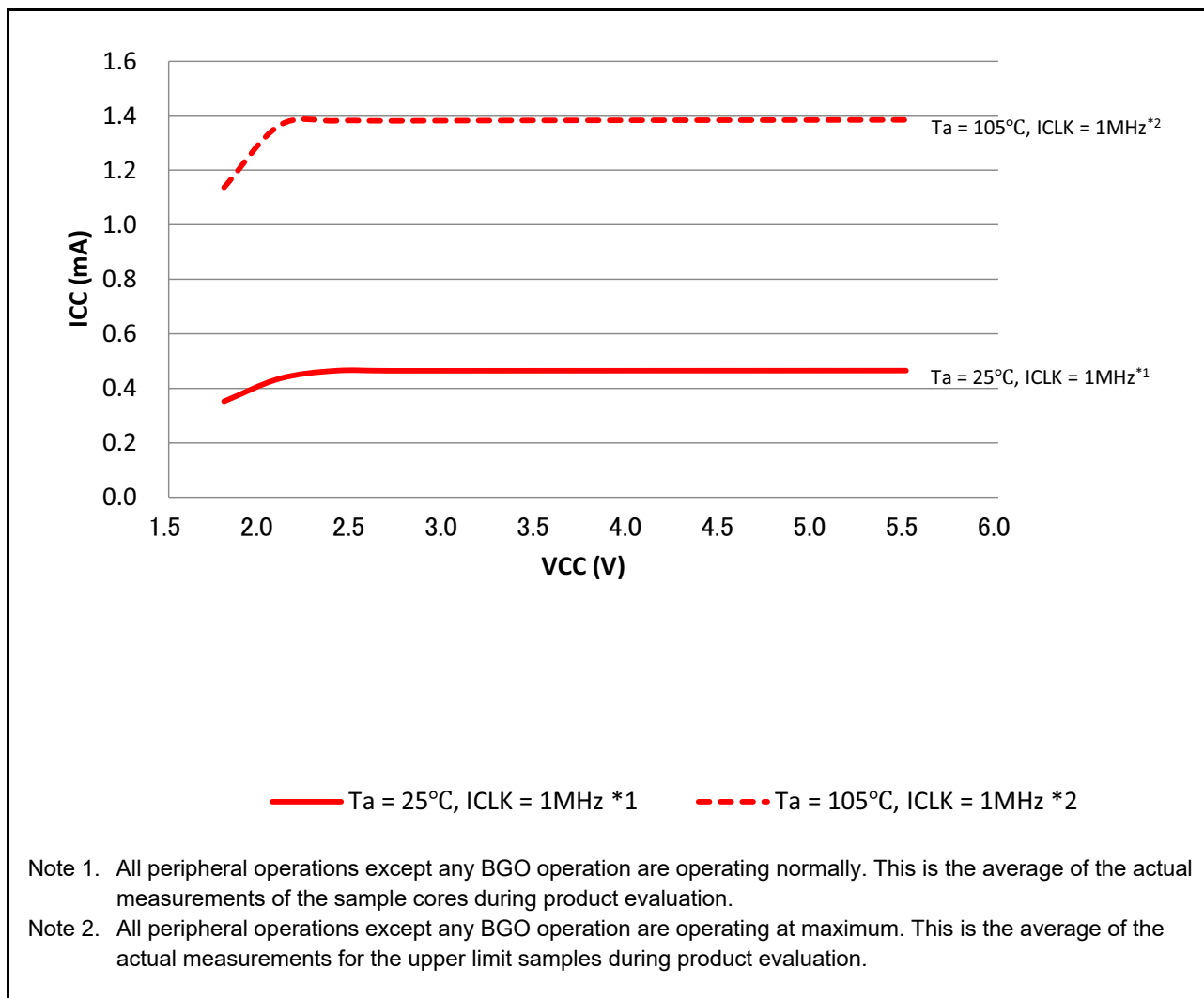

Figure 2.19 Voltage dependency in low-speed operating mode (reference data)

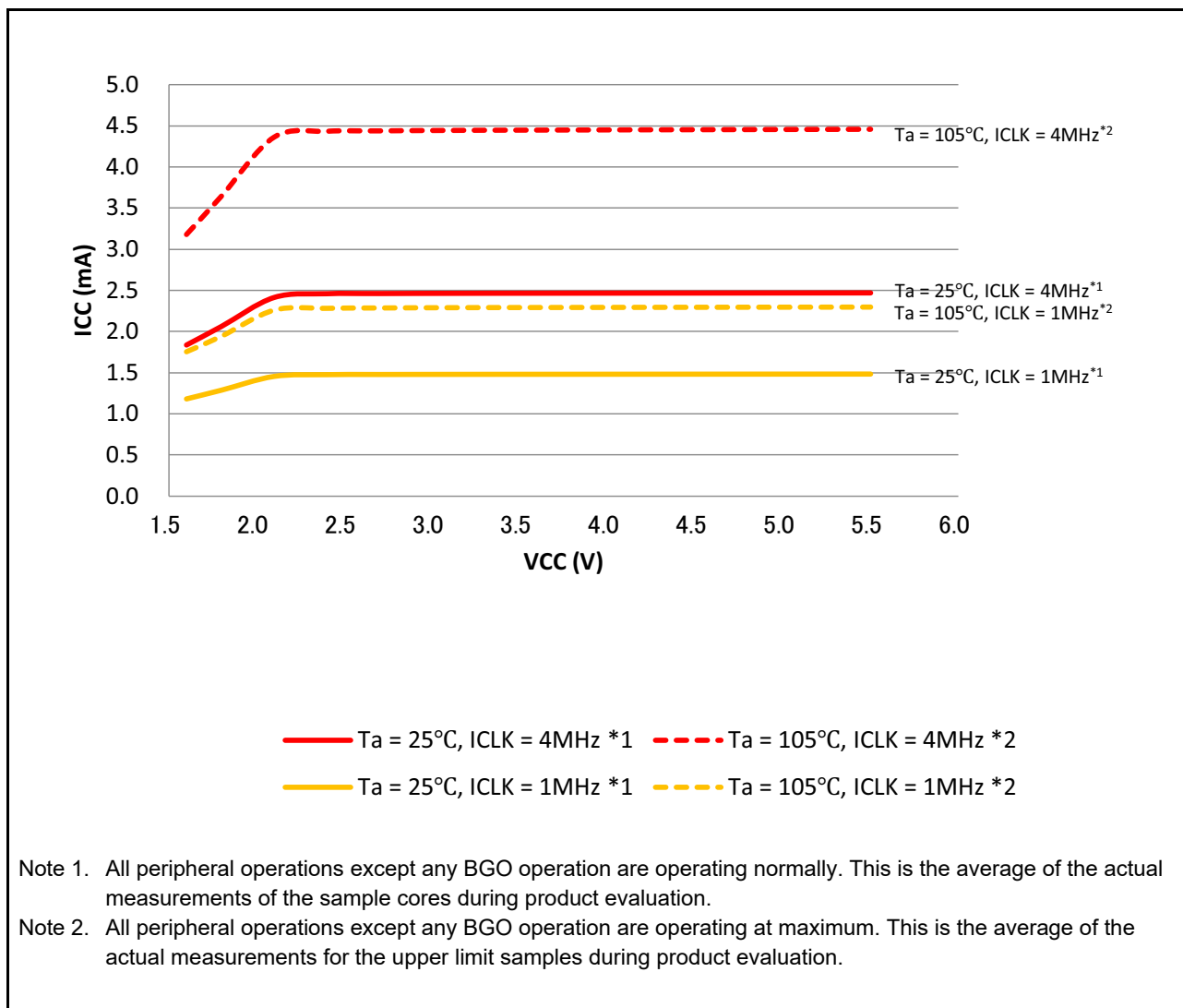

Figure 2.20 Voltage dependency in low-voltage operating mode (reference data)

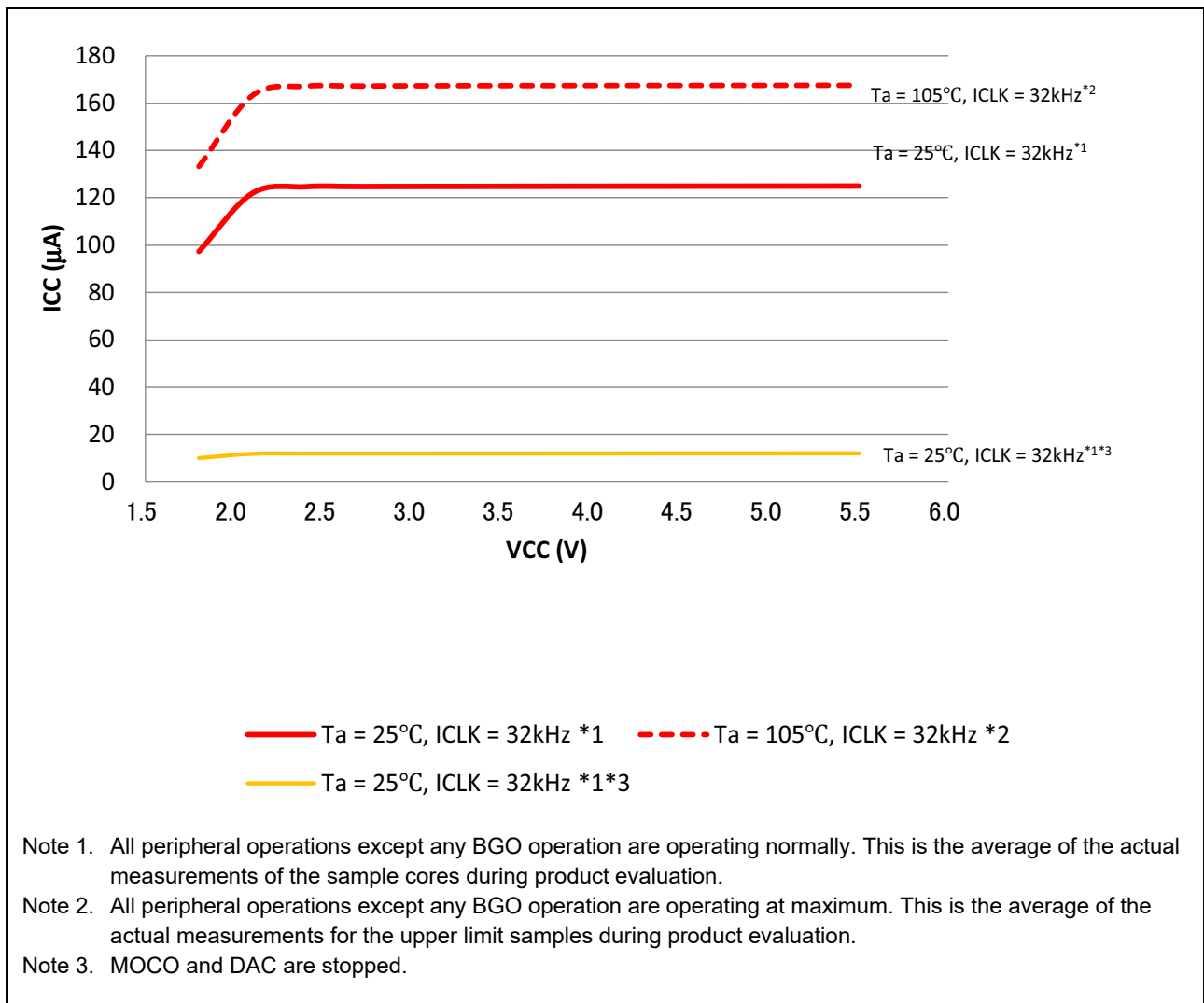

Figure 2.21 Voltage dependency in subosc-speed operating mode (reference data)

Table 2.11 Operating and standby current (2)

Conditions: VCC = AVCC0 = AVCC1 = 1.6 to 5.5 V

| Parameter | Symbol | Typ*3 | Max | Unit | Test conditions | | |
|------------------|---|------------------------|-----------------|------|---|----|---|
| Supply current*1 | Software Standby mode*2 | T _a = 25°C | I _{CC} | 0.5 | 2.0 | µA | - |
| | | T _a = 55°C | 0.8 | 7.0 | | | |
| | | T _a = 85°C | 1.8 | 17.0 | | | |
| | | T _a = 105°C | 4.4 | 45.0 | | | |
| | Increment for RTC operation with low-speed on-chip oscillator*4 | | 0.4 | - | - | | |
| | Increment for RTC operation with sub-clock oscillator*4 | | 0.5 | - | SOMCR.SODRV[1:0] are 11b (Low power mode 3) | | |
| | | | 1.3 | - | SOMCR.SODRV[1:0] are 00b (normal mode) | | |

Note 1. Supply current values do not include output charge/discharge current from all pins. The values apply when internal pull-up MOS transistors are in the off state.

Note 2. The IWDT and LVD are not operating.

Note 3. VCC = 3.3 V.

Note 4. Includes the low-speed on-chip oscillator or sub-oscillation circuit current.

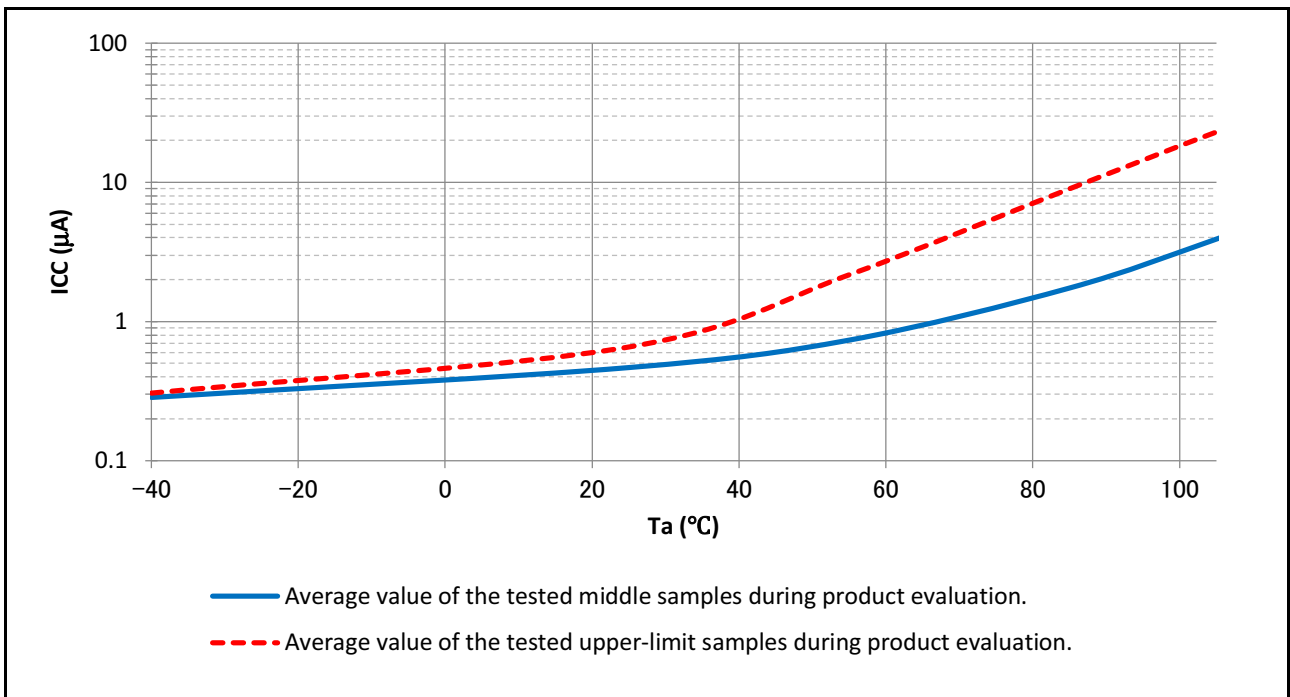
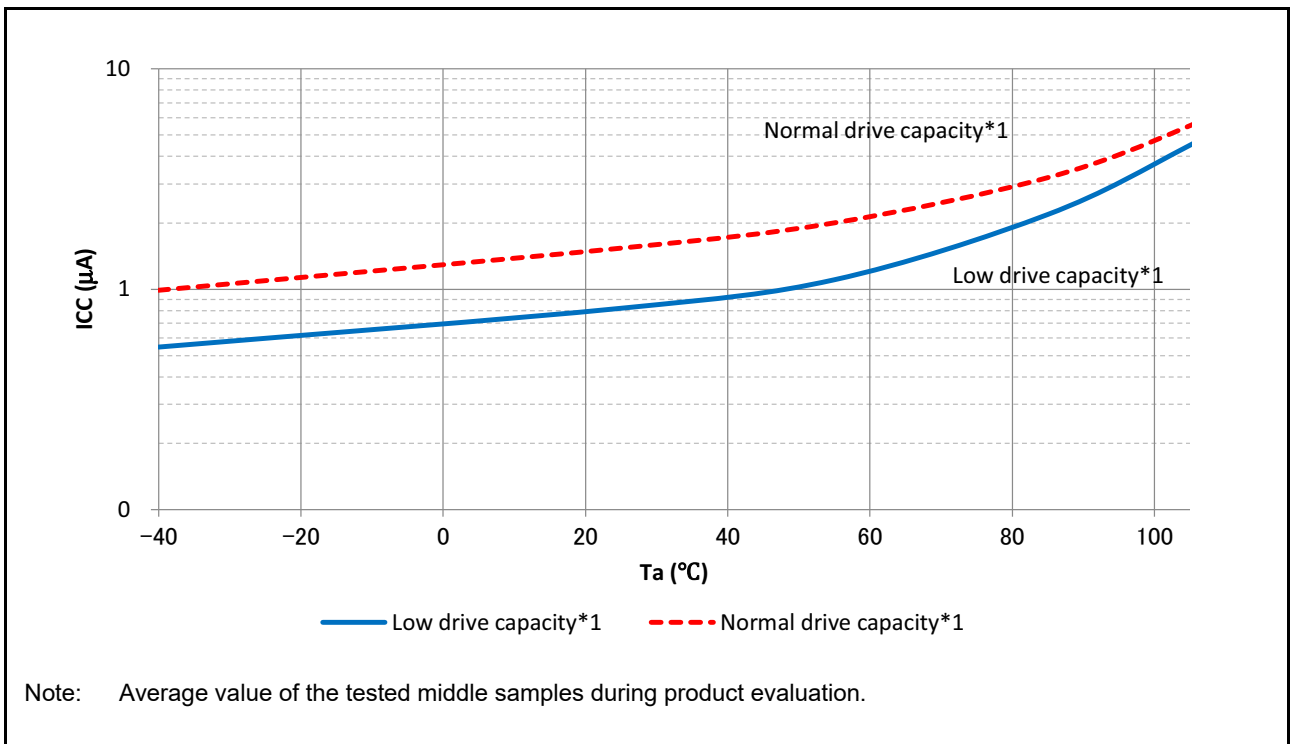

Figure 2.22 Temperature dependency in Software Standby mode (reference data)



Note: Average value of the tested middle samples during product evaluation.

Figure 2.23 Temperature dependency of RTC operation (reference data)

Table 2.12 Operating and standby current (3)

Conditions: VCC = AVCC0 = AVCC1 = 1.6 to 5.5 V

| Parameter | | Symbol | Min | Typ | Max | Unit | Test conditions | |
|---|---|----------------------|------------------|-------------------------------|------|---------------|--|---|
| Analog power supply current | During 16-bit A/D conversion | I _{AVCC0} | - | - | 1.5 | mA | - | |
| | During 8-bit D/A conversion (per channel) *1 | | - | - | 1.6 | mA | - | |
| | During 12-bit D/A conversion (per channel) *1 | | - | - | 0.9 | mA | - | |
| | Waiting for 16-bit A/D, 8-bit D/A and 12-bit D/A conversion (all units) *5 | | - | - | 2.0 | μA | - | |
| | During 24-bit sigma-delta A/D conversion (at normal mode) | I _{AVCC1} | - | - | 1.29 | mA | - | |
| | During 24-bit sigma-delta A/D conversion (at low-power conversion) | | - | - | 1.06 | mA | G _{SET1} = 8, or G _{TOTAL} = 24,32 | |
| | Waiting for 24-bit sigma-delta A/D conversion*6 | | - | - | 0.9 | mA | G _{SET1} , G _{TOTAL} = the others | |
| | | | - | - | 1.0 | μA | - | |
| Reference power supply current | During 16-bit A/D conversion | I _{REFH0} | - | - | 80 | μA | - | |
| | Waiting for 16-bit A/D conversion | | - | - | 60 | nA | - | |
| | During 12-bit D/A conversion | I _{REFH} | - | - | 650 | μA | - | |
| | Waiting for 12-bit D/A conversion | | - | - | 100 | nA | - | |
| | During 24-bit sigma-delta A/D conversion | I _{REFI} | - | - | 30 | μA | External VREF mode | |
| Temperature Sensor (TSN) operating current | I _{TNS} | - | 75 | - | μA | - | | |
| Low-power Analog Comparator (ACMPLP) operating current | Window comparator (high-speed mode) | I _{CMPLP} | - | 15 | - | μA | - | |
| | Comparator (high-speed mode) | | - | 10 | - | μA | - | |
| | Comparator (low-speed mode) | | - | 2 | - | μA | - | |
| High-speed analog comparator (ACMPHS) operating current | I _{CPMHS} | - | 70 | 100 | μA | AVCC0 ≥ 2.7 V | | |
| Operational Amplifier (OPAMP) operating current | Low power mode | I _{AMP} | 1 unit operating | - | 10 | 16 | μA | - |
| | | | 2 unit operating | - | 19 | 30 | μA | - |
| | | | 3 unit operating | - | 28 | 44 | μA | - |
| | Middle speed mode | | 1 unit operating | - | 280 | 360 | μA | - |
| | | | 2 unit operating | - | 530 | 690 | μA | - |
| | | | 3 unit operating | - | 770 | 1020 | μA | - |
| | High speed mode | | 1 unit operating | - | 0.74 | 0.91 | mA | - |
| | | | 2 unit operating | - | 1.41 | 1.74 | mA | - |
| | | | 3 unit operating | - | 2.07 | 2.57 | mA | - |
| Internal reference voltage for ADC16 operating current | I _{VREFADC} | - | 65 | 130 | μA | - | | |
| USBFS operating current | During USB communication under the following settings and conditions: • Function controller is in Full-Speed mode and - Bulk OUT transfer is (64 bytes) × 1 - Bulk IN transfer is (64 bytes) × 1 • Host device is connected by a 1-meter USB cable from the USB port. | I _{USBF} *2 | - | 3.6 (VCC) 1.1 (VCC_USB)*4 | - | mA | - | |
| | During suspended state under the following setting and conditions: • Function controller is in Full-Speed mode (the USB_DP pin is pulled up) • Software Standby mode • Host device is connected through a 1-meter USB cable from the USB port. | I _{SUSP} *3 | - | 0.35 (VCC) 170 (VCC_USB)*4 | - | μA | - | |

Note 1. The reference power supply current is included in the power supply current value for D/A conversion.

Note 2. Current is consumed only by the USBFS.

Note 3. Includes the current supplied from the pull-up resistor of the USB_DP pin to the pull-down resistor of the host device, in addition to the current consumed by the MCU in the suspended state.

Note 4. When VCC = VCC_USB = 3.3 V.

Note 5. When the MCU is in Software Standby mode or the MSTPCRD.MSTPD16 (ADC160 module-stop bit) is in the module-stop

state.

Note 6. When the MCU is in the MSTPCRD.MSTPD17 (SDADC24 module-stop bit) is in the module-stop state.

2.2.10 VCC Rise and Fall Gradient and Ripple Frequency

Table 2.13 Rise and fall gradient characteristics

Conditions: VCC = AVCC0 = AVCC1 = 0 to 5.5 V

| Parameter | Symbol | Min | Typ | Max | Unit | Test conditions | |
|------------------------------|--|-------|------|-----|------|-----------------|---|
| Power-on VCC rising gradient | Voltage monitor 0 reset disabled at startup | SrVCC | 0.02 | - | 2 | ms/V | - |
| | Voltage monitor 0 reset enabled at startup*1, *2 | | | | - | | |
| | SCI/USB boot mode*2 | | | | 2 | | |

Note 1. When OFS1.LVDAS = 0.

Note 2. At boot mode, the reset from voltage monitor 0 is disabled regardless of the value of OFS1.LVDAS bit.

Table 2.14 Rising and falling gradient and ripple frequency characteristics

Conditions: VCC = AVCC0 = AVCC1 = 1.6 to 5.5 V

The ripple voltage must meet the allowable ripple frequency $f_{r(VCC)}$ within the range between the VCC upper limit (5.5 V) and lower limit (1.6 V).

When the VCC change exceeds $VCC \pm 10\%$, the allowable voltage change rising and falling gradient $dt/dVCC$ must be met.

| Parameter | Symbol | Min | Typ | Max | Unit | Test conditions |
|--|--------------|-----|-----|-----|------|--|
| Allowable ripple frequency | $f_{r(VCC)}$ | - | - | 10 | kHz | Figure 2.24 $V_{r(VCC)} \leq VCC \times 0.2$ |
| | | - | - | 1 | MHz | Figure 2.24 $V_{r(VCC)} \leq VCC \times 0.08$ |
| | | - | - | 10 | MHz | Figure 2.24 $V_{r(VCC)} \leq VCC \times 0.06$ |
| Allowable voltage change rising and falling gradient | $dt/dVCC$ | 1.0 | - | - | ms/V | When VCC change exceeds $VCC \pm 10\%$ |

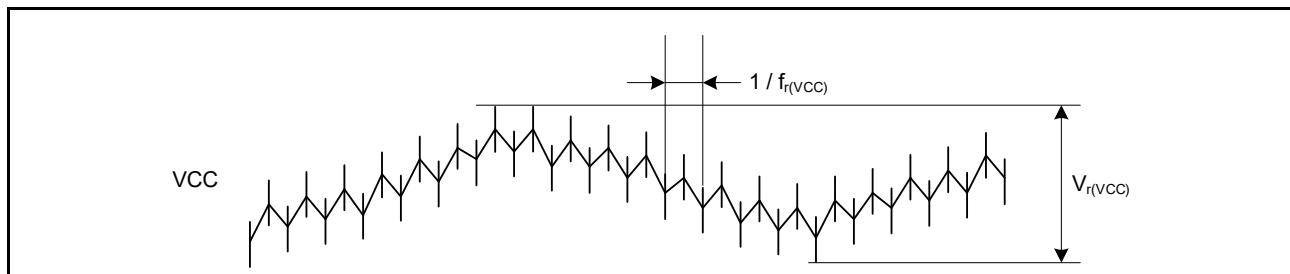

Figure 2.24 Ripple waveform

2.3 AC Characteristics

2.3.1 Frequency

Table 2.15 Operation frequency in high-speed operating mode

Conditions: VCC = AVCC0 = AVCC1 = 2.4 to 5.5 V

| Parameter | | | Symbol | Min | Typ | Max*7 | Unit |
|---------------------|--------------------------------------|--------------|--------|----------|-----|-------|------|
| Operation frequency | System clock (ICLK)*6 | 2.7 to 5.5 V | f | 0.032768 | - | 48 | MHz |
| | | 2.4 to 2.7 V | | 0.032768 | - | 16 | |
| | FlashIF clock (FCLK)*1,*2,*6 | 2.7 to 5.5 V | | 0.032768 | - | 32 | |
| | | 2.4 to 2.7 V | | 0.032768 | - | 16 | |
| | Peripheral module clock (PCLKB)*5,*6 | 2.7 to 5.5 V | | - | - | 32 | |
| | | 2.4 to 2.7 V | | - | - | 16 | |
| | Peripheral module clock (PCLKD)*3,*6 | 2.7 to 5.5 V | | - | - | 64*4 | |
| | | 2.4 to 2.7 V | | - | - | 16 | |

- Note 1. The lower-limit frequency of FCLK is 1 MHz while programming or erasing the flash memory. When using FCLK for programming or erasing the flash memory at below 4 MHz, the frequency can be set to 1 MHz, 2 MHz, or 3 MHz. A non-integer frequency such as 1.5 MHz cannot be set.
- Note 2. The frequency accuracy of FCLK must be $\pm 3.5\%$ during programming or erasing the flash memory. Confirm the frequency accuracy of the clock source.
- Note 3. The lower-limit frequency of PCLKD is 1 MHz when the ADC16 is in use.
- Note 4. The upper-limit frequency of PCLKD is 32 MHz when the ADC16 is in use.
- Note 5. The lower-limit frequency of PCLKB is 1 MHz when the SDADC24 is in use.
- Note 6. See section 9, Clock Generation Circuit in User's Manual for the relationship of frequencies between ICLK, PCLKB, PCLKD, and FCLK.
- Note 7. The maximum value of operation frequency does not include internal oscillator errors. For details on the range for guaranteed operation, see [Table 2.20, Clock timing](#).

Table 2.16 Operation frequency in middle-speed mode

Conditions: VCC = AVCC0 = AVCC1 = 1.8 to 5.5 V

| Parameter | | | Symbol | Min | Typ | Max*6 | Unit |
|---------------------|--------------------------------------|--------------|--------|----------|-----|-------|------|
| Operation frequency | System clock (ICLK)*5 | 2.7 to 5.5 V | f | 0.032768 | - | 12 | MHz |
| | | 2.4 to 2.7 V | | 0.032768 | - | 12 | |
| | | 1.8 to 2.4 V | | 0.032768 | - | 8 | |
| | FlashIF clock (FCLK)*1,*2,*5 | 2.7 to 5.5 V | | 0.032768 | - | 12 | |
| | | 2.4 to 2.7 V | | 0.032768 | - | 12 | |
| | | 1.8 to 2.4 V | | 0.032768 | - | 8 | |
| | Peripheral module clock (PCLKB)*4,*5 | 2.7 to 5.5 V | | - | - | 12 | |
| | | 2.4 to 2.7 V | | - | - | 12 | |
| | | 1.8 to 2.4 V | | - | - | 8 | |
| | Peripheral module clock (PCLKD)*3,*5 | 2.7 to 5.5 V | | - | - | 12 | |
| | | 2.4 to 2.7 V | | - | - | 12 | |
| | | 1.8 to 2.4 V | | - | - | 8 | |

- Note 1. The lower-limit frequency of FCLK is 1 MHz while programming or erasing the flash memory. When using FCLK for programming or erasing the flash memory at below 4 MHz, the frequency can be set to 1 MHz, 2 MHz, or 3 MHz. A non-integer frequency such as 1.5 MHz cannot be set.
- Note 2. The frequency accuracy of FCLK must be $\pm 3.5\%$ while programming or erasing the flash memory. Confirm the frequency accuracy of the clock source.
- Note 3. The lower-limit frequency of PCLKD is 1 MHz when the ADC16 is in use.
- Note 4. The lower-limit frequency of PCLKB is 1 MHz when the SDADC24 is in use.
- Note 5. See section 9, Clock Generation Circuit in User's Manual for the relationship of frequencies between ICLK,

PCLKB, PCLKD, and FCLK.

Note 6. The maximum value of operation frequency does not include internal oscillator errors. For details on the range for guaranteed operation, see [Table 2.20, Clock timing](#).

Table 2.17 Operation frequency in low-speed mode

Conditions: VCC = AVCC0 = AVCC1 = 1.8 to 5.5 V

| Parameter | | | Symbol | Min | Typ | Max*6 | Unit |
|---------------------|--------------------------------------|--------------|--------|----------|-----|-------|------|
| Operation frequency | System clock (ICLK)*5 | 1.8 to 5.5 V | f | 0.032768 | - | 1 | MHz |
| | FlashIF clock (FCLK) *1,*2,*5 | 1.8 to 5.5 V | | 0.032768 | - | 1 | |
| | Peripheral module clock (PCLKB)*4,*5 | 1.8 to 5.5 V | | - | - | 1 | |
| | Peripheral module clock (PCLKD)*3,*5 | 1.8 to 5.5 V | | - | - | 1 | |

Note 1. The lower-limit frequency of FCLK is 1 MHz while programming or erasing the flash memory.

Note 2. The frequency accuracy of FCLK must be $\pm 3.5\%$ while programming or erasing the flash memory. Confirm the frequency accuracy of the clock source.

Note 3. The lower-limit frequency of PCLKD is 1 MHz when the ADC16 is in use.

Note 4. The lower-limit frequency of PCLKB is 1 MHz when the SDADC24 is in use.

Note 5. See section 9, Clock Generation Circuit in User's Manual for the relationship of frequencies between ICLK, PCLKB, PCLKD, and FCLK.

Note 6. The maximum value of operation frequency does not include internal oscillator errors. For details on the range for guaranteed operation, see [Table 2.20, Clock timing](#).

Table 2.18 Operation frequency in low-voltage mode

Conditions: VCC = AVCC0 = AVCC1 = 1.6 to 5.5 V

| Parameter | | | Symbol | Min | Typ | Max*6 | Unit |
|---------------------|--------------------------------------|--------------|--------|----------|-----|-------|------|
| Operation frequency | System clock (ICLK)*5 | 1.6 to 5.5 V | f | 0.032768 | - | 4 | MHz |
| | FlashIF clock (FCLK)*1,*2,*5 | 1.6 to 5.5 V | | 0.032768 | - | 4 | |
| | Peripheral module clock (PCLKB)*4,*5 | 1.6 to 5.5 V | | - | - | 4 | |
| | Peripheral module clock (PCLKD)*3,*5 | 1.6 to 5.5 V | | - | - | 4 | |

Note 1. The lower-limit frequency of FCLK is 1 MHz while programming or erasing the flash memory. When using FCLK for programming or erasing the flash memory at below 4 MHz, the frequency can be set to 1 MHz, 2 MHz, or 3 MHz. A non-integer frequency such as 1.5 MHz cannot be set.

Note 2. The frequency accuracy of FCLK must be $\pm 3.5\%$ during programming or erasing the flash memory. Confirm the frequency accuracy of the clock source.

Note 3. The lower-limit frequency of PCLKD is 1 MHz when the ADC16 is in use.

Note 4. The lower-limit frequency of PCLKB is 1 MHz when the SDADC24 is in use.

Note 5. See section 9, Clock Generation Circuit in User's Manual for the relationship of frequencies between ICLK, PCLKB, PCLKD, and FCLK.

Note 6. The maximum value of operation frequency does not include internal oscillator errors. For details on the range for guaranteed operation, see [Table 2.20, Clock timing](#).

Table 2.19 Operation frequency in Subosc-speed mode

Conditions: VCC = AVCC0 = AVCC1 = 1.8 to 5.5 V

| Parameter | | | Symbol | Min | Typ | Max | Unit |
|---------------------|--------------------------------------|--------------|--------|---------|--------|---------|------|
| Operation frequency | System clock (ICLK)*4 | 1.8 to 5.5 V | f | 27.8528 | 32.768 | 37.6832 | kHz |
| | FlashIF clock (FCLK)*1,*4 | 1.8 to 5.5 V | | 27.8528 | 32.768 | 37.6832 | |
| | Peripheral module clock (PCLKB)*3,*4 | 1.8 to 5.5 V | | - | - | 37.6832 | |
| | Peripheral module clock (PCLKD)*2,*4 | 1.8 to 5.5 V | | - | - | 37.6832 | |

Note 1. Programming and erasing the flash memory is not possible.

Note 2. The ADC16 cannot be used.

Note 3. The SDADC24 cannot be used.

Note 4. See section 9, Clock Generation Circuit in User's Manual for the relationship of frequencies between ICLK, PCLKB, PCLKD, and FCLK.

2.3.2 Clock Timing

Table 2.20 Clock timing (1 of 2)

| Parameter | Symbol | Min | Typ | Max | Unit | Test conditions |
|---|--|--------------|--------|--|---------|---|
| EXTAL external clock input cycle time | t_{Xcyc} | 50 | - | - | ns | Figure 2.25 |
| EXTAL external clock input high pulse width | t_{XH} | 20 | - | - | ns | |
| EXTAL external clock input low pulse width | t_{XL} | 20 | - | - | ns | |
| EXTAL external clock rising time | t_{Xr} | - | - | 5 | ns | |
| EXTAL external clock falling time | t_{Xf} | - | - | 5 | ns | |
| EXTAL external clock input wait time*1 | t_{EXWT} | 0.3 | - | - | μ s | - |
| EXTAL external clock input frequency | f_{EXTAL} | - | - | 20 | MHz | $2.4 \leq VCC \leq 5.5$ |
| | | - | - | 8 | | $1.8 \leq VCC < 2.4$ |
| | | - | - | 1 | | $1.6 \leq VCC < 1.8$ |
| Main clock oscillator oscillation frequency | f_{MAIN} | 1 | - | 20 | MHz | $2.4 \leq VCC \leq 5.5$ |
| | | 1 | - | 8 | | $1.8 \leq VCC < 2.4$ |
| | | 1 | - | 4 | | $1.6 \leq VCC < 1.8$ |
| LOCO clock oscillation frequency | f_{LOCO} | 27.8528 | 32.768 | 37.6832 | kHz | - |
| LOCO clock oscillation stabilization time | t_{LOCO} | - | - | 100 | μ s | Figure 2.26 |
| IWDT-dedicated clock oscillation frequency | f_{ILOCO} | 12.75 | 15 | 17.25 | kHz | - |
| MOCO clock oscillation frequency | f_{MOCO} | 6.8 | 8 | 9.2 | MHz | - |
| MOCO clock oscillation stabilization time | t_{MOCO} | - | - | 1 | μ s | - |
| HOCO clock oscillation frequency | f_{HOCO24} | 23.64 | 24 | 24.36 | MHz | $T_a = -40$ to -20°C $1.8 \leq VCC \leq 5.5$ |
| | | 22.68 | 24 | 25.32 | | $T_a = -40$ to 85°C $1.6 \leq VCC < 1.8$ |
| | | 23.76 | 24 | 24.24 | | $T_a = -20$ to 85°C $1.8 \leq VCC \leq 5.5$ |
| | | 23.52 | 24 | 24.48 | | $T_a = 85$ to 105°C $2.4 \leq VCC \leq 5.5$ |
| | f_{HOCO32} | 31.52 | 32 | 32.48 | | $T_a = -40$ to -20°C $1.8 \leq VCC \leq 5.5$ |
| | | 30.24 | 32 | 33.76 | | $T_a = -40$ to 85°C $1.6 \leq VCC < 1.8$ |
| | | 31.68 | 32 | 32.32 | | $T_a = -20$ to 85°C $1.8 \leq VCC \leq 5.5$ |
| | | 31.36 | 32 | 32.64 | | $T_a = 85$ to 105°C $2.4 \leq VCC \leq 5.5$ |
| | f_{HOCO48}^{*3} | 47.28 | 48 | 48.72 | | $T_a = -40$ to -20°C $1.8 \leq VCC \leq 5.5$ |
| | | 47.52 | 48 | 48.48 | | $T_a = -20$ to 85°C $1.8 \leq VCC \leq 5.5$ |
| | | 47.04 | 48 | 48.96 | | $T_a = 85$ to 105°C $2.4 \leq VCC \leq 5.5$ |
| | f_{HOCO64}^{*4} | 63.04 | 64 | 64.96 | | $T_a = -40$ to -20°C $2.4 \leq VCC \leq 5.5$ |
| 63.36 | | 64 | 64.64 | $T_a = -20$ to 85°C $2.4 \leq VCC \leq 5.5$ | | |
| 62.72 | | 64 | 65.28 | $T_a = 85$ to 105°C $2.4 \leq VCC \leq 5.5$ | | |
| HOCO clock oscillation stabilization time*5, *6 | Except low-voltage mode | t_{HOCO24} | - | - | μ s | Figure 2.27 |
| | | t_{HOCO32} | - | - | | |
| | | t_{HOCO48} | - | - | | |
| | t_{HOCO64} | - | - | | | |
| Low-voltage mode | t_{HOCO24} t_{HOCO32} t_{HOCO48} t_{HOCO64} | - | - | 100.9 | | |
| Sub-clock oscillator oscillation frequency | f_{SUB} | - | 32.768 | - | kHz | - |

Table 2.20 Clock timing (2 of 2)

| Parameter | Symbol | Min | Typ | Max | Unit | Test conditions |
|--|--------------|-----|-----|-----|------|-----------------|
| Sub-clock oscillation stabilization time*2 | t_{SUBOSC} | - | 0.5 | - | s | Figure 2.28 |

- Note 1. Time until the clock can be used after the Main Clock Oscillator stop bit (MOSCCR.MOSTP) is set to 0 (operating) when the external clock is stable.
- Note 2. After changing the setting of the SOSCCR.SOSTP bit to start sub-clock oscillator operation, only start using the sub-clock oscillator after the sub-clock oscillation stabilization wait time elapsed. Use the oscillator wait time value recommended by the oscillator manufacturer.
- Note 3. The 48-MHz HOCO can be used within a VCC range of 1.8 V to 5.5 V.
- Note 4. The 64-MHz HOCO can be used within a VCC range of 2.4 V to 5.5 V.
- Note 5. This is a characteristic when the HOCO.CR.HCSTP bit is cleared to 0 (oscillation) in the MOCO stop state. When the HOCO.CR.HCSTP bit is set to 0 (oscillation) during MOCO oscillation, this specification is shortened by 1 μ s.
- Note 6. Check OSCSF.HOCOSF to confirm whether stabilization time has elapsed.

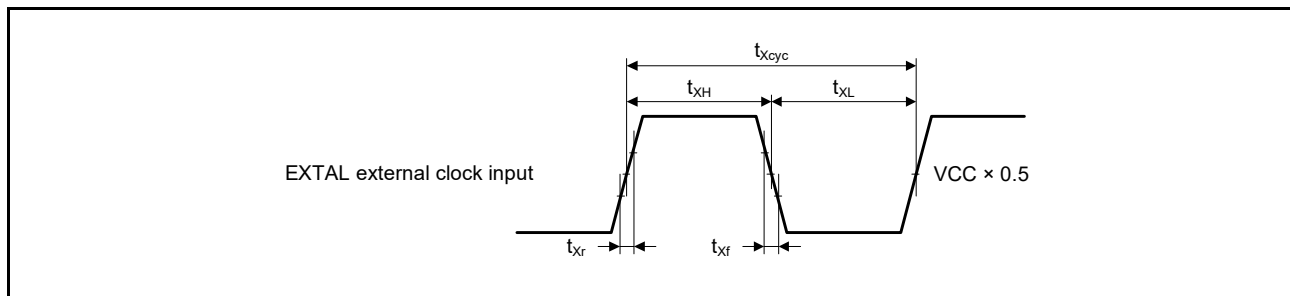

Figure 2.25 EXTAL external clock input timing

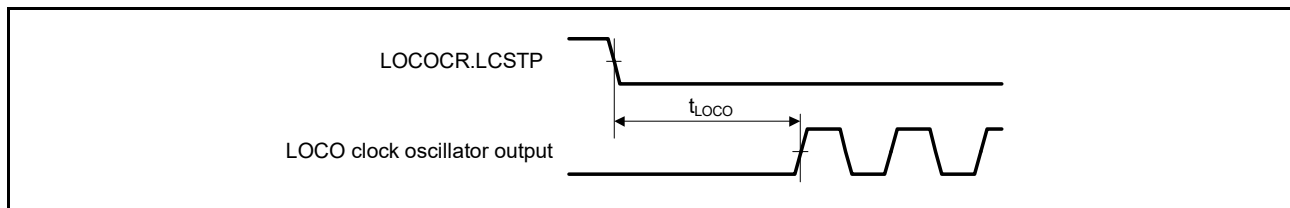

Figure 2.26 LOCO clock oscillator start timing

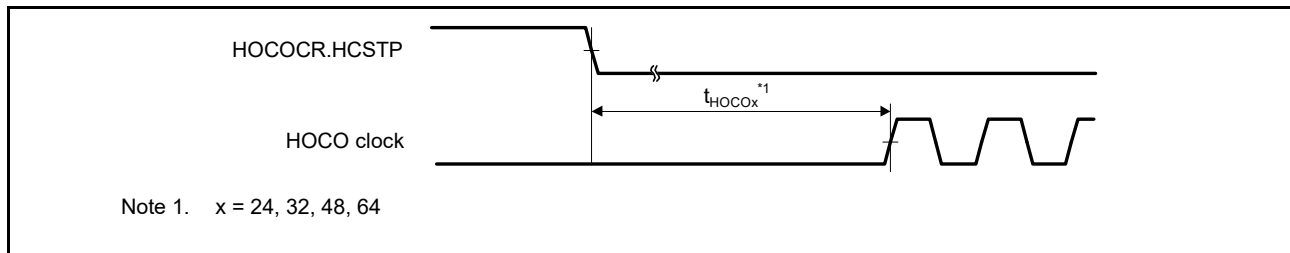

Figure 2.27 HOCO clock oscillator start timing (started by setting the HOCO.CR.HCSTP bit)

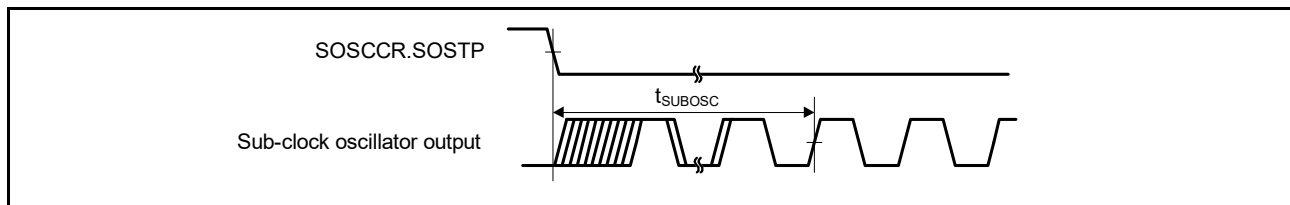

Figure 2.28 Sub-clock oscillator start timing

2.3.3 Reset Timing

Table 2.21 Reset timing

| Parameter | | Symbol | Min | Typ | Max | Unit | Test conditions |
|---|-----------------|--------------|-----|------|-----|---------|-----------------|
| RES pulse width | At power-on | t_{RESWP} | 3 | - | - | ms | Figure 2.29 |
| | Not at power-on | t_{RESW} | 30 | - | - | μ s | Figure 2.30 |
| Wait time after RES cancellation (at power-on) | LVD0 enabled*1 | t_{RESWT} | - | 0.7 | - | ms | Figure 2.29 |
| | LVD0 disabled*2 | | - | 0.3 | - | | |
| Wait time after RES cancellation (during powered-on state) | LVD0 enabled*1 | t_{RESWT2} | - | 0.5 | - | ms | Figure 2.30 |
| | LVD0 disabled*2 | | - | 0.1 | - | | |
| Wait time after internal reset cancellation (Watchdog timer reset, SRAM parity error reset, SRAM ECC error reset, bus master MPU error reset, bus slave MPU error reset, stack pointer error reset, software reset) | LVD0 enabled*1 | t_{RESWT3} | - | 0.6 | - | ms | Figure 2.31 |
| | LVD0 disabled*2 | | - | 0.15 | - | | |

Note 1. When OFS1.LVDAS = 0.

Note 2. When OFS1.LVDAS = 1.

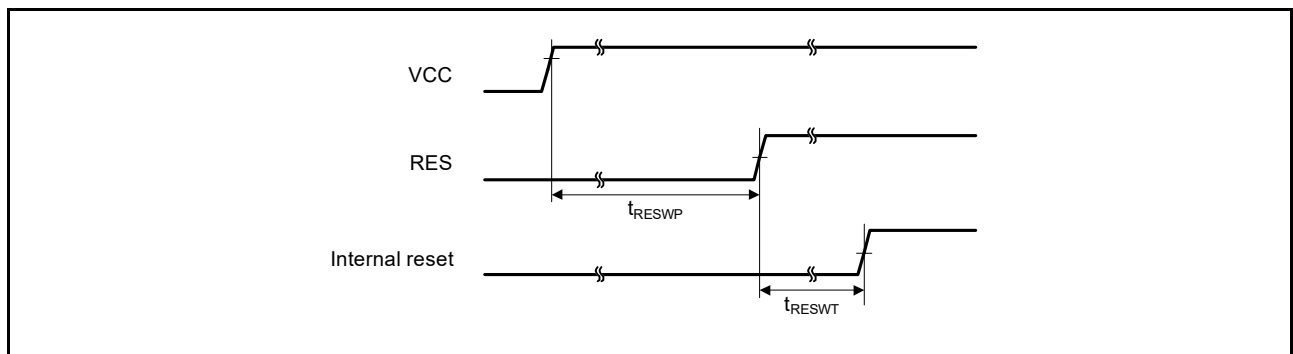

Figure 2.29 Reset input timing at power-on

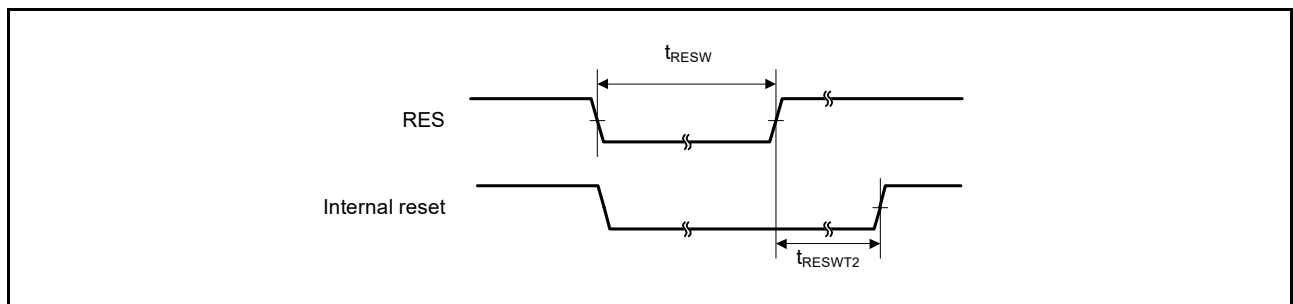

Figure 2.30 Reset input timing (1)

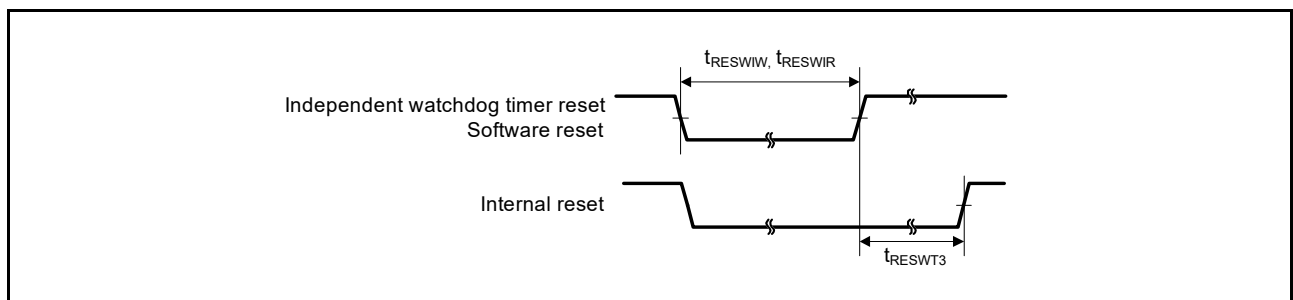

Figure 2.31 Reset input timing (2)

2.3.4 Wakeup Time

Table 2.22 Timing of recovery from low power modes (1)

| Parameter | | | | Symbol | Min | Typ | Max | Unit | Test conditions |
|--|-----------------|--|---|--------------------|-----|-----|-----|------|-----------------|
| Recovery time from Software Standby mode*1 | High-speed mode | Crystal resonator connected to main clock oscillator | System clock source is main clock oscillator (20 MHz)*2 | t _{SBYMC} | - | 2 | 3 | ms | Figure 2.32 |
| | | External clock input to main clock oscillator | System clock source is main clock oscillator (20 MHz)*3 | t _{SBYEX} | - | 14 | 25 | μs | |
| | | System clock source is HOCO*4 (HOCO clock is 32 MHz) | | t _{SBYHO} | - | 43 | 52 | μs | |
| | | System clock source is HOCO*4 (HOCO clock is 48 MHz) | | t _{SBYHO} | - | 44 | 52 | μs | |
| | | System clock source is HOCO*5 (HOCO clock is 64 MHz) | | t _{SBYHO} | - | 82 | 110 | μs | |
| | | System clock source is MOCO | | t _{SBYMO} | - | 16 | 25 | μs | |

Note 1. The division ratio of ICK, FCK, and PCKx is the minimum division ratio within the allowable frequency range. The recovery time is determined by the system clock source.

Note 2. The Main Clock Oscillator Wait Control Register (MOSCWTCR) is set to 05h.

Note 3. The Main Clock Oscillator Wait Control Register (MOSCWTCR) is set to 00h.

Note 4. The HOCO Clock Wait Control Register (HOCOWTCR) is set to 05h.

Note 5. The HOCO Clock Wait Control Register (HOCOWTCR) is set to 06h.

Table 2.23 Timing of recovery from low power modes (2)

| Parameter | | | | Symbol | Min | Typ | Max | Unit | Test conditions |
|--|-------------------|--|---|--------------------|-----|-----|-----|------|-----------------|
| Recovery time from Software Standby mode*1 | Middle-speed mode | Crystal resonator connected to main clock oscillator | System clock source is main clock oscillator (12 MHz)*2 | t _{SBYMC} | - | 2 | 3 | ms | Figure 2.32 |
| | | External clock input to main clock oscillator | System clock source is main clock oscillator (12 MHz)*3 | t _{SBYEX} | - | 2.9 | 10 | μs | |
| | | System clock source is HOCO*4 | | t _{SBYHO} | - | 38 | 50 | μs | |
| | | System clock source is MOCO (8 MHz) | | t _{SBYMO} | - | 3.5 | 5.5 | μs | |

Note 1. The division ratio of ICK, FCK, and PCKx is the minimum division ratio within the allowable frequency range. The recovery time is determined by the system clock source.

Note 2. The Main Clock Oscillator Wait Control Register (MOSCWTCR) is set to 05h.

Note 3. The Main Clock Oscillator Wait Control Register (MOSCWTCR) is set to 00h.

Note 4. The system clock is 12 MHz.

Table 2.24 Timing of recovery from low power modes (3)

| Parameter | | | | Symbol | Min | Typ | Max | Unit | Test conditions |
|--|----------------|--|--|-------------|-----|-----|-----|---------|-----------------|
| Recovery time from Software Standby mode*1 | Low-speed mode | Crystal resonator connected to main clock oscillator | System clock source is main clock oscillator (1 MHz)*2 | t_{SBYMC} | - | 2 | 3 | ms | Figure 2.32 |
| | | External clock input to main clock oscillator | System clock source is main clock oscillator (1 MHz)*3 | t_{SBYEX} | - | 28 | 50 | μ s | |
| | | System clock source is MOCO (1 MHz) | | t_{SBYMO} | - | 25 | 35 | μ s | |

Note 1. The division ratio of ICK, FCK, and PCKx is the minimum division ratio within the allowable frequency range. The recovery time is determined by the system clock source.

Note 2. The Main Clock Oscillator Wait Control Register (MOSCWTCR) is set to 05h.

Note 3. The Main Clock Oscillator Wait Control Register (MOSCWTCR) is set to 00h.

Table 2.25 Timing of recovery from low power modes (4)

| Parameter | | | | Symbol | Min | Typ | Max | Unit | Test conditions |
|--|------------------|--|--|-------------|-----|-----|-----|---------|-----------------|
| Recovery time from Software Standby mode*1 | Low-voltage mode | Crystal resonator connected to main clock oscillator | System clock source is main clock oscillator (4 MHz)*2 | t_{SBYMC} | - | 2 | 3 | ms | Figure 2.32 |
| | | External clock input to main clock oscillator | System clock source is main clock oscillator (4 MHz)*3 | t_{SBYEX} | - | 108 | 130 | μ s | |
| | | System clock source is HOCO (4 MHz) | | t_{SBYHO} | - | 108 | 130 | μ s | |

Note 1. The division ratio of ICK, FCK, and PCKx is the minimum division ratio within the allowable frequency range. The recovery time is determined by the system clock source.

Note 2. The Main Clock Oscillator Wait Control Register (MOSCWTCR) is set to 05h.

Note 3. The Main Clock Oscillator Wait Control Register (MOSCWTCR) is set to 00h.

Table 2.26 Timing of recovery from low power modes (5)

| Parameter | | | Symbol | Min | Typ | Max | Unit | Test conditions |
|--|-------------------|--|-------------|-----|------|-----|------|-----------------|
| Recovery time from Software Standby mode*1 | Subosc-speed mode | System clock source is sub-clock oscillator (32.768 kHz) | t_{SBYSC} | - | 0.85 | 1 | ms | Figure 2.32 |
| | | System clock source is LOCO (32.768 kHz) | t_{SBYLO} | - | 0.85 | 1.2 | ms | |

Note 1. The sub-clock oscillator or LOCO itself continues oscillating in Software Standby mode during Subosc-speed mode.

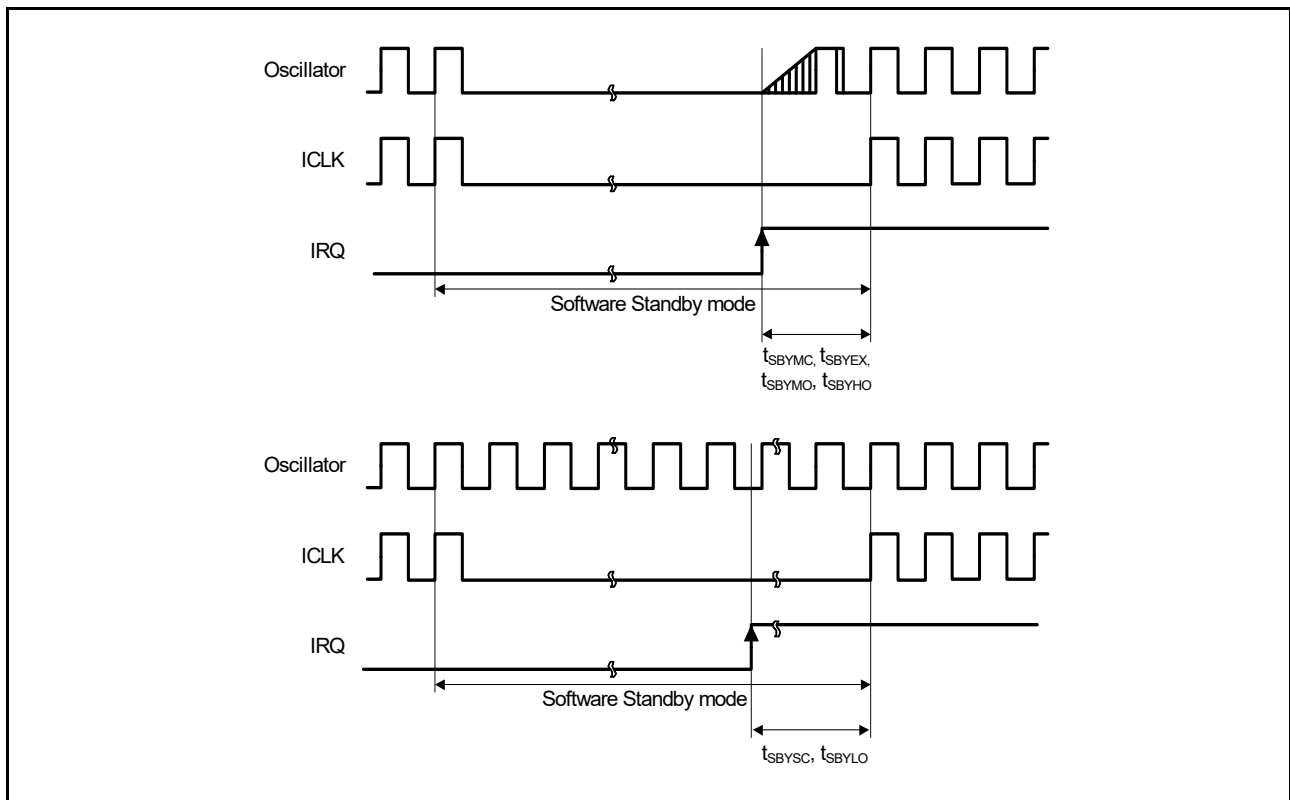

Figure 2.32 Software Standby mode cancellation timing

Table 2.27 Timing of recovery from low power modes (6)

| Parameter | | Symbol | Min | Typ | Max | Unit | Test conditions |
|---|--|-----------|-----|-----|-----|---------|-----------------|
| Recovery time from Software Standby mode to Snooze mode | High-speed mode System clock source is HOCO | t_{SNZ} | - | 36 | 45 | μs | Figure 2.33 |
| | Middle-speed mode System clock source is MOCO (8 MHz) | t_{SNZ} | - | 1.3 | 3.6 | μs | |
| | Low-speed mode System clock source is MOCO (1 MHz) | t_{SNZ} | - | 10 | 13 | μs | |
| | Low-voltage mode System clock source is HOCO (4 MHz) | t_{SNZ} | - | 87 | 110 | μs | |

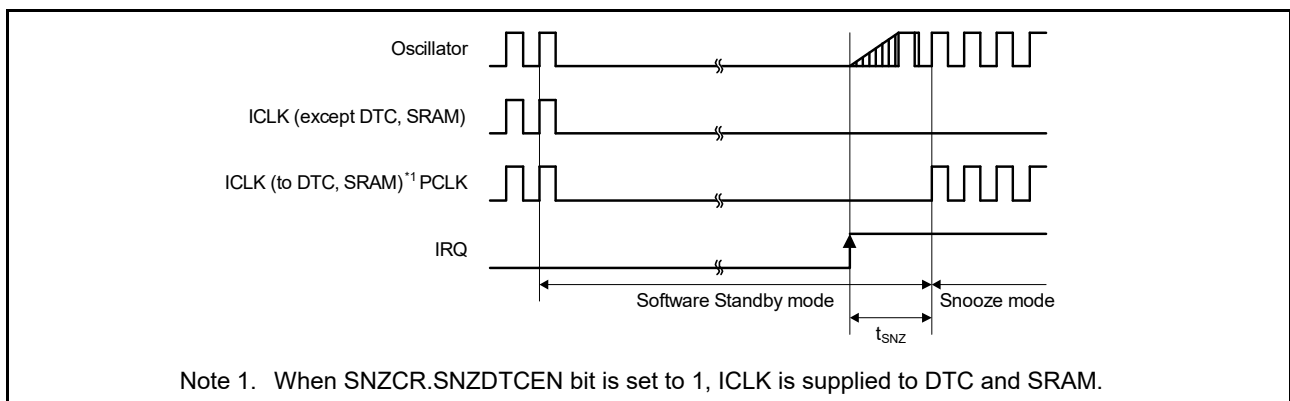

Figure 2.33 Recovery timing from Software Standby mode to Snooze mode

2.3.5 NMI and IRQ Noise Filter

Table 2.28 NMI and IRQ noise filter

| Parameter | Symbol | Min | Typ | Max | Unit | Test conditions | |
|-----------------|-------------------|------------------------------------|-----|-----|------|-----------------------------|---|
| NMI pulse width | t_{NMIW} | 200 | - | - | ns | NMI digital filter disabled | $t_{\text{Pcyc}} \times 2 \leq 200$ ns |
| | | $t_{\text{Pcyc}} \times 2^{*1}$ | - | - | | | $t_{\text{Pcyc}} \times 2 > 200$ ns |
| | | 200 | - | - | | NMI digital filter enabled | $t_{\text{NMICK}} \times 3 \leq 200$ ns |
| | | $t_{\text{NMICK}} \times 3.5^{*2}$ | - | - | | | $t_{\text{NMICK}} \times 3 > 200$ ns |
| IRQ pulse width | t_{IRQW} | 200 | - | - | ns | IRQ digital filter disabled | $t_{\text{Pcyc}} \times 2 \leq 200$ ns |
| | | $t_{\text{Pcyc}} \times 2^{*1}$ | - | - | | | $t_{\text{Pcyc}} \times 2 > 200$ ns |
| | | 200 | - | - | | IRQ digital filter enabled | $t_{\text{IRQCK}} \times 3 \leq 200$ ns |
| | | $t_{\text{IRQCK}} \times 3.5^{*3}$ | - | - | | | $t_{\text{IRQCK}} \times 3 > 200$ ns |

Note: 200 ns minimum in Software Standby mode.

Note: If the clock source is switched, add 4 clock cycles of the switched source.

Note 1. t_{Pcyc} indicates the PCLKB cycle.

Note 2. t_{NMICK} indicates the cycle of the NMI digital filter sampling clock.

Note 3. t_{IRQCK} indicates the cycle of the IRQ_i digital filter sampling clock (i = 0 to 7).

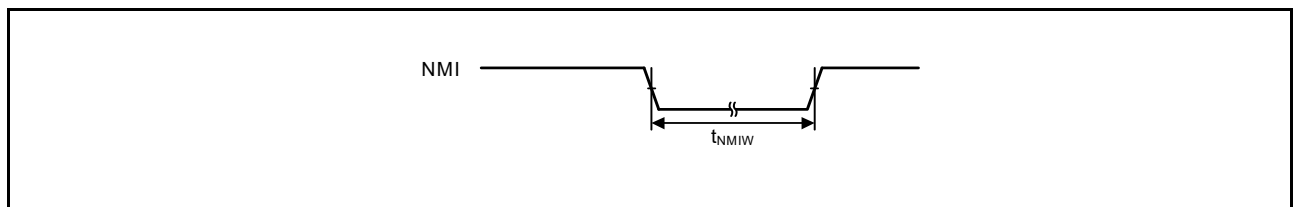

Figure 2.34 NMI interrupt input timing

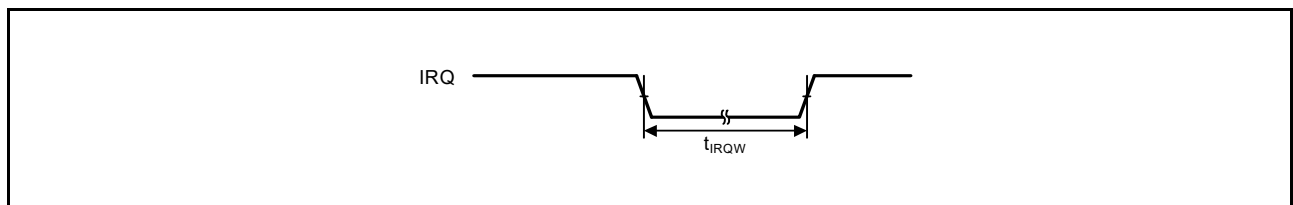

Figure 2.35 IRQ interrupt input timing

2.3.6 I/O Ports, POEG, GPT, AGT, KINT, and ADC16 Trigger Timing

Table 2.29 I/O Ports, POEG, GPT, AGT, KINT, and ADC16 trigger timing

| Parameter | | Symbol | Min | Max | Unit | Test conditions | |
|-----------|--|--|------------------------------|------|-------------|-----------------|-------------|
| I/O Ports | Input data pulse width | t_{PRW} | 1.5 | - | t_{Pcyc} | Figure 2.36 | |
| POEG | POEG input trigger pulse width | t_{POEW} | 3 | - | t_{Pcyc} | Figure 2.37 | |
| GPT | Input capture pulse width | Single edge | 1.5 | - | t_{PDcyc} | Figure 2.38 | |
| | | Dual edge | 2.5 | - | | | |
| AGT | AGTIO, AGTEE input cycle | $2.7\text{ V} \leq V_{CC} \leq 5.5\text{ V}$ | t_{ACYC}^{*1} | 250 | - | ns | Figure 2.39 |
| | | $2.4\text{ V} \leq V_{CC} < 2.7\text{ V}$ | | 500 | - | | |
| | | $1.8\text{ V} \leq V_{CC} < 2.4\text{ V}$ | | 1000 | - | | |
| | | $1.6\text{ V} \leq V_{CC} < 1.8\text{ V}$ | | 2000 | - | | |
| | AGTIO, AGTEE input high-level width, low-level width | $2.7\text{ V} \leq V_{CC} \leq 5.5\text{ V}$ | t_{ACKWH} , t_{ACKWL} | 100 | - | ns | |
| | | $2.4\text{ V} \leq V_{CC} < 2.7\text{ V}$ | | 200 | - | | |
| | | $1.8\text{ V} \leq V_{CC} < 2.4\text{ V}$ | 400 | - | ns | | |
| | | $1.6\text{ V} \leq V_{CC} < 1.8\text{ V}$ | 800 | - | ns | | |
| | AGTIO, AGTO, AGTOA, AGTOB output cycle | $2.7\text{ V} \leq V_{CC} \leq 5.5\text{ V}$ | t_{ACYC2} | 62.5 | - | ns | |
| | | $2.4\text{ V} \leq V_{CC} < 2.7\text{ V}$ | | 125 | - | | |
| | | $1.8\text{ V} \leq V_{CC} < 2.4\text{ V}$ | | 250 | - | | |
| | | $1.6\text{ V} \leq V_{CC} < 1.8\text{ V}$ | | 500 | - | | |
| ADC16 | 16-bit A/D converter trigger input pulse width | t_{TRGW} | 1.5 | - | t_{Pcyc} | Figure 2.40 | |
| KINT | KRn (n = 00 to 07) pulse width | t_{KR} | 250 | - | ns | Figure 2.41 | |

Note: t_{Pcyc} : PCLKB cycle, t_{PDcyc} : PCLKD cycle.

Note 1. Constraints on input cycle:

When not switching the source clock: $t_{Pcyc} \times 2 < t_{ACYC}$ should be satisfied.

When switching the source clock: $t_{Pcyc} \times 6 < t_{ACYC}$ should be satisfied.

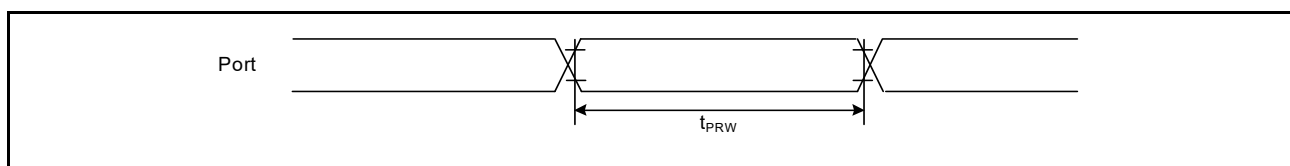

Figure 2.36 I/O ports input timing

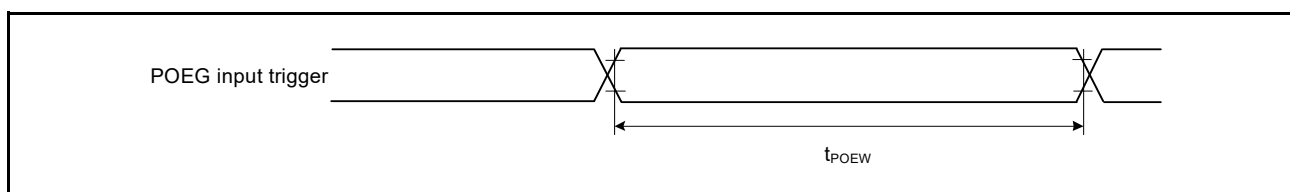

Figure 2.37 POEG input trigger timing

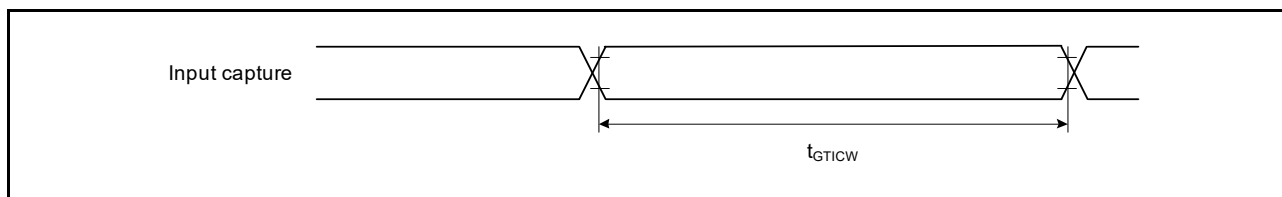

Figure 2.38 GPT input capture timing

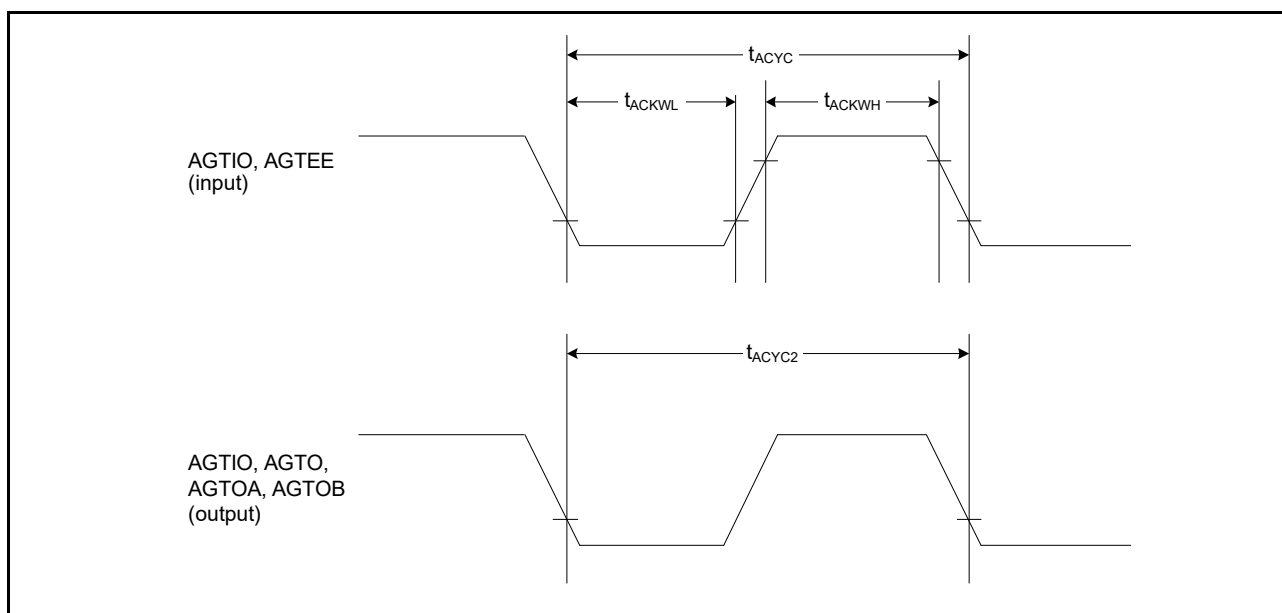

Figure 2.39 AGT I/O timing

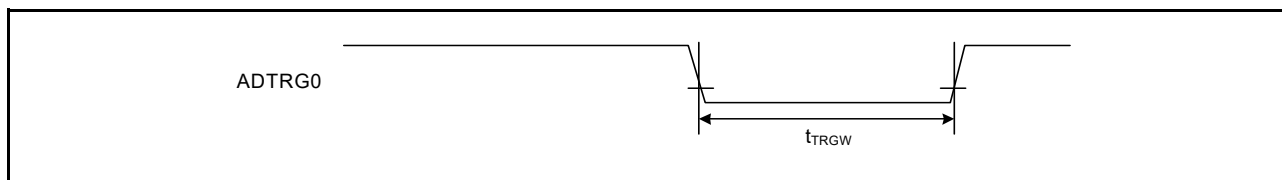

Figure 2.40 ADC16 trigger input timing

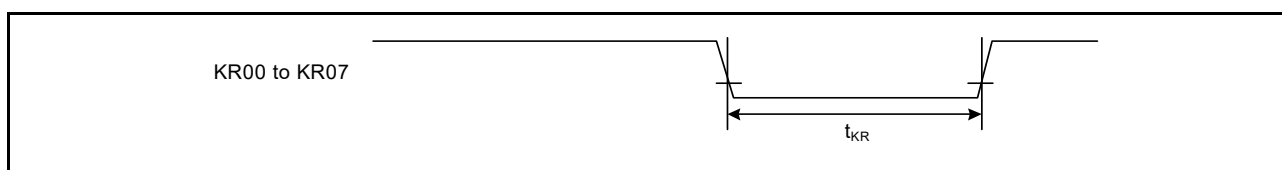

Figure 2.41 Key interrupt input timing

2.3.7 CAC Timing

Table 2.30 CAC timing
 Conditions: $V_{CC} = AV_{CC0} = AV_{CC1} = 1.6$ to 5.5 V

| Parameter | | Symbol | Min | Typ | Max | Unit | Test conditions |
|-----------|--------------------------|---------------------------------|--------------|--|-----|------|-----------------|
| CAC | CACREF input pulse width | $t_{Pcyc} * 1 \leq t_{cac} * 2$ | t_{CACREF} | $4.5 \times t_{cac} + 3 \times t_{Pcyc}$ | - | - | ns |
| | | $t_{Pcyc} * 1 > t_{cac} * 2$ | | $5 \times t_{cac} + 6.5 \times t_{Pcyc}$ | - | - | ns |

Note 1. t_{Pcyc} : PCLKB cycle.

Note 2. t_{cac} : CAC count clock source cycle.

2.3.8 SCI Timing

Table 2.31 SCI timing (1)

Conditions: $V_{CC} = AV_{CC0} = AV_{CC1} = 1.6$ to 5.5 V

| Parameter | | | Symbol | Min | Max | Unit*1 | Test conditions | |
|----------------------------------|------------------------------|-------------------|--|--|-----|------------|-----------------|----|
| SCI | Input clock cycle | Asynchronous | t_{Scyc} | 4 | - | t_{Pcyc} | Figure 2.42 | |
| | | Clock synchronous | | 6 | - | | | |
| | Input clock pulse width | | t_{SCKW} | 0.4 | 0.6 | t_{Scyc} | | |
| | Input clock rise time | | t_{SCKr} | - | 20 | ns | | |
| | Input clock fall time | | t_{SCKf} | - | 20 | ns | | |
| | Output clock cycle | Asynchronous | t_{Scyc} | 6 | - | t_{Pcyc} | | |
| | | Clock synchronous | | 4 | - | | | |
| | Output clock pulse width | | t_{SCKW} | 0.4 | 0.6 | t_{Scyc} | | |
| | Output clock rise time | | t_{SCKr} | $1.8 \text{ V} \leq V_{CC} \leq 5.5 \text{ V}$ | - | 20 | | ns |
| | | | | $1.6 \text{ V} \leq V_{CC} < 1.8 \text{ V}$ | - | 30 | | |
| | Output clock fall time | | t_{SCKf} | $1.8 \text{ V} \leq V_{CC} \leq 5.5 \text{ V}$ | - | 20 | | ns |
| | | | | $1.6 \text{ V} \leq V_{CC} < 1.8 \text{ V}$ | - | 30 | | |
| | Transmit data delay (master) | Clock synchronous | t_{TXD} | $1.8 \text{ V} \leq V_{CC} \leq 5.5 \text{ V}$ | - | 40 | | ns |
| | | | | $1.6 \text{ V} \leq V_{CC} < 1.8 \text{ V}$ | - | 45 | | |
| Transmit data delay (slave) | Clock synchronous | t_{TXD} | $2.7 \text{ V} \leq V_{CC} \leq 5.5 \text{ V}$ | - | 55 | ns | | |
| | | | $2.4 \text{ V} \leq V_{CC} < 2.7 \text{ V}$ | - | 60 | | | |
| | | | $1.8 \text{ V} \leq V_{CC} < 2.4 \text{ V}$ | - | 100 | | | |
| | | | $1.6 \text{ V} \leq V_{CC} < 1.8 \text{ V}$ | - | 125 | | | |
| Receive data setup time (master) | Clock synchronous | t_{RXS} | $2.7 \text{ V} \leq V_{CC} \leq 5.5 \text{ V}$ | 45 | - | ns | | |
| | | | $2.4 \text{ V} \leq V_{CC} < 2.7 \text{ V}$ | 55 | - | | | |
| | | | $1.8 \text{ V} \leq V_{CC} < 2.4 \text{ V}$ | 90 | - | | | |
| | | | $1.6 \text{ V} \leq V_{CC} < 1.8 \text{ V}$ | 110 | - | | | |
| Receive data setup time (slave) | Clock synchronous | t_{RXS} | $2.7 \text{ V} \leq V_{CC} \leq 5.5 \text{ V}$ | 40 | - | ns | | |
| | | | $1.6 \text{ V} \leq V_{CC} < 2.7 \text{ V}$ | 45 | - | | | |
| Receive data hold time (master) | Clock synchronous | t_{RXH} | 5 | - | ns | | | |
| Receive data hold time (slave) | Clock synchronous | t_{RXH} | 40 | - | ns | | | |

Note 1. t_{Pcyc} : PCLKB cycle.

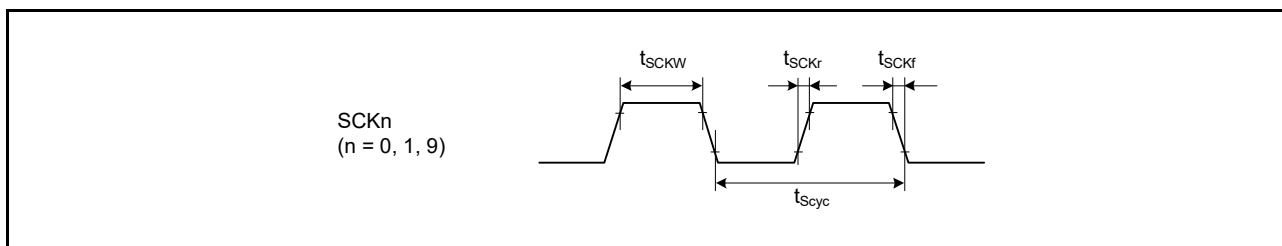

Figure 2.42 SCK clock input timing

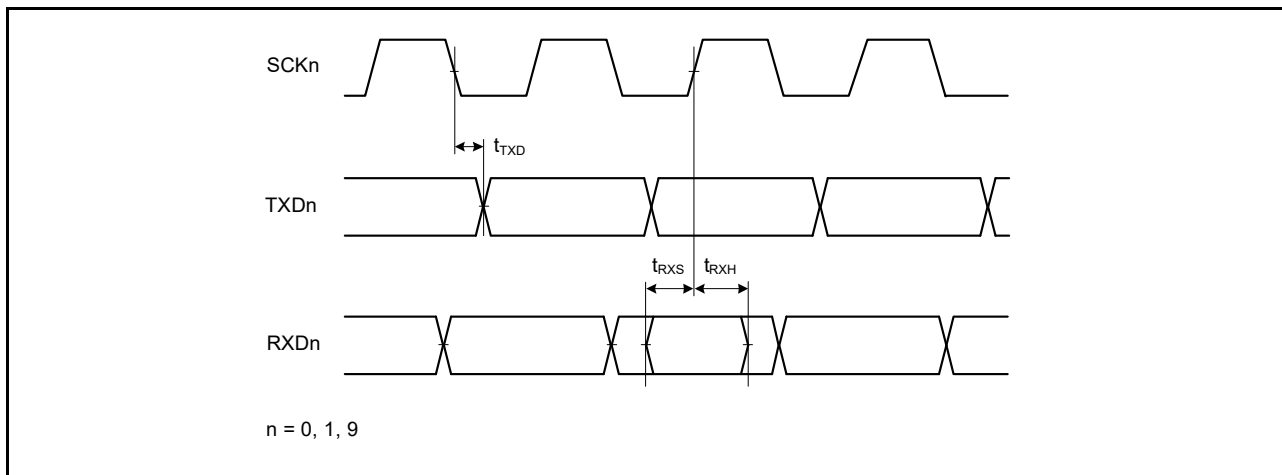

Figure 2.43 SCI input/output timing in clock synchronous mode

Table 2.32 SCI timing (2)

Conditions: VCC = AVCC0 = AVCC1 = 1.6 to 5.5 V

| Parameter | | | Symbol | Min | Max | Unit*1 | Test conditions | |
|--|---------------------------------|---|---|---|------------------|-------------|-----------------|----------------------------|
| Simple SPI | SCK clock cycle output (master) | | t_{SPcyc} | 4 | 65536 | t_{Pcyc} | Figure 2.44 | |
| | SCK clock cycle input (slave) | | | 6 | 65536 | | | |
| | SCK clock high pulse width | | t_{SPCKWH} | 0.4 | 0.6 | t_{SPcyc} | | |
| | SCK clock low pulse width | | t_{SPCKWL} | 0.4 | 0.6 | t_{SPcyc} | | |
| | SCK clock rise and fall time | | t_{SPCKr} t_{SPCKf} | $1.8\text{ V} \leq VCC \leq 5.5\text{ V}$ | - | 20 | ns | |
| | | | | $1.6\text{ V} \leq VCC < 1.8\text{ V}$ | - | 30 | | |
| | Data input setup time | Master | $2.7\text{ V} \leq VCC \leq 5.5\text{ V}$ | t_{SU} | 45 | - | ns | Figure 2.45 to Figure 2.48 |
| | | | $2.4\text{ V} \leq VCC < 2.7\text{ V}$ | | 55 | - | | |
| | | | $1.8\text{ V} \leq VCC < 2.4\text{ V}$ | | 80 | - | | |
| | | | $1.6\text{ V} \leq VCC < 1.8\text{ V}$ | | 110 | - | | |
| | | Slave | $2.7\text{ V} \leq VCC \leq 5.5\text{ V}$ | | 40 | - | | |
| | | | $1.6\text{ V} \leq VCC < 2.7\text{ V}$ | | 45 | - | | |
| | Data input hold time | Master | | t_H | 33.3 | - | ns | |
| | | Slave | | | 40 | - | | |
| SS input setup time | | | t_{LEAD} | 1 | - | t_{SPcyc} | | |
| SS input hold time | | | t_{LAG} | 1 | - | t_{SPcyc} | | |
| Data output delay | Master | $1.8\text{ V} \leq VCC \leq 5.5\text{ V}$ | t_{OD} | - | 40 | ns | | |
| | | $1.6\text{ V} \leq VCC < 1.8\text{ V}$ | | - | 50 | | | |
| | Slave | $2.4\text{ V} \leq VCC \leq 5.5\text{ V}$ | | - | 65 | | | |
| | | $1.8\text{ V} \leq VCC < 2.4\text{ V}$ | | - | 100 | | | |
| | | $1.6\text{ V} \leq VCC < 1.8\text{ V}$ | | - | 125 | | | |
| Data output hold time | Master | $2.7\text{ V} \leq VCC \leq 5.5\text{ V}$ | t_{OH} | -10 | - | ns | | |
| | | $2.4\text{ V} \leq VCC < 2.7\text{ V}$ | | -20 | - | | | |
| | | $1.8\text{ V} \leq VCC < 2.4\text{ V}$ | | -30 | - | | | |
| | | $1.6\text{ V} \leq VCC < 1.8\text{ V}$ | | -40 | - | | | |
| | Slave | | | | -10 | | - | |
| | Data rise and fall time | Master | | $1.8\text{ V} \leq VCC \leq 5.5\text{ V}$ | t_{Dr}, t_{Df} | | - | 20 |
| $1.6\text{ V} \leq VCC < 1.8\text{ V}$ | | | - | 30 | | | | |
| Slave | | $1.8\text{ V} \leq VCC \leq 5.5\text{ V}$ | - | 20 | | | | |
| | | $1.6\text{ V} \leq VCC < 1.8\text{ V}$ | - | 30 | | | | |
| Simple SPI | Slave access time | | t_{SA} | - | 6 | t_{Pcyc} | Figure 2.48 | |
| | Slave output release time | | t_{REL} | - | 6 | t_{Pcyc} | | |

Note 1. t_{Pcyc} : PCLKB cycle.

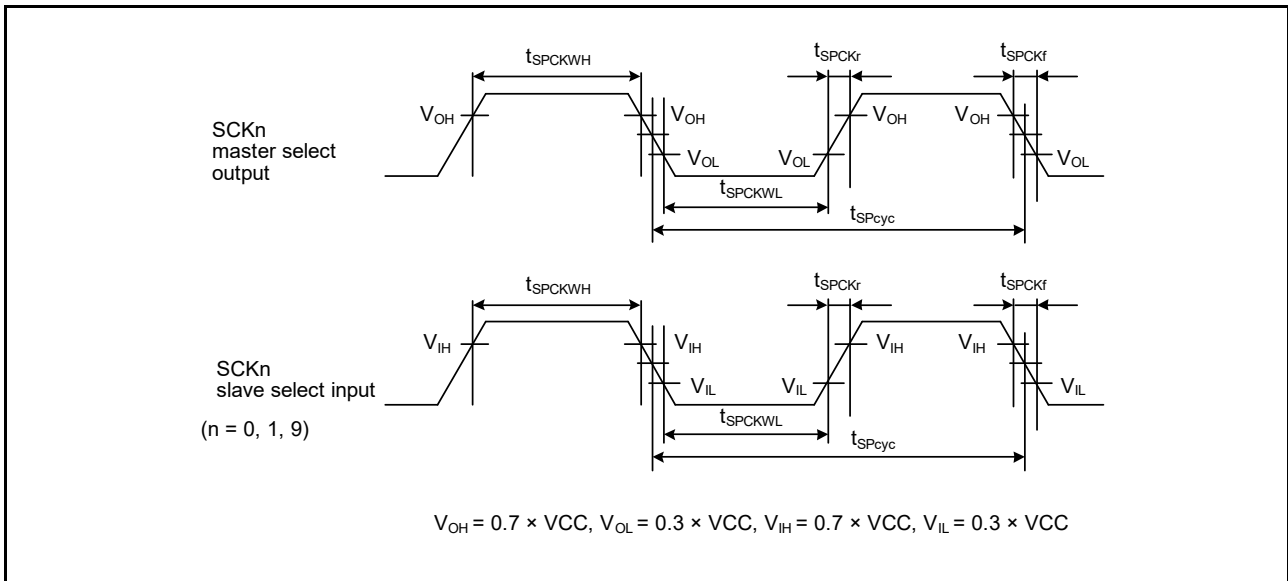

Figure 2.44 SCI simple SPI mode clock timing

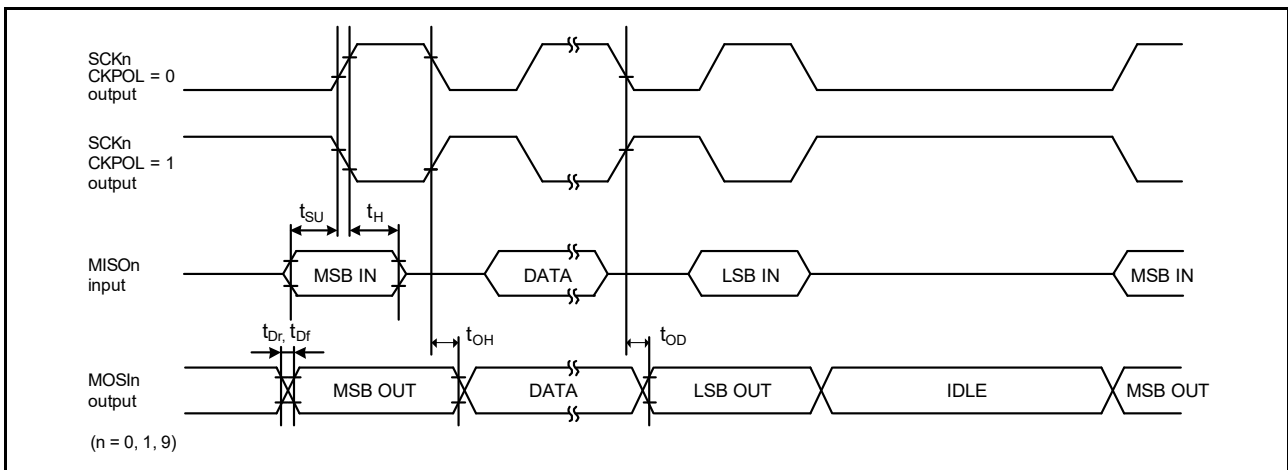

Figure 2.45 SCI simple SPI mode timing (master, CKPH = 1)

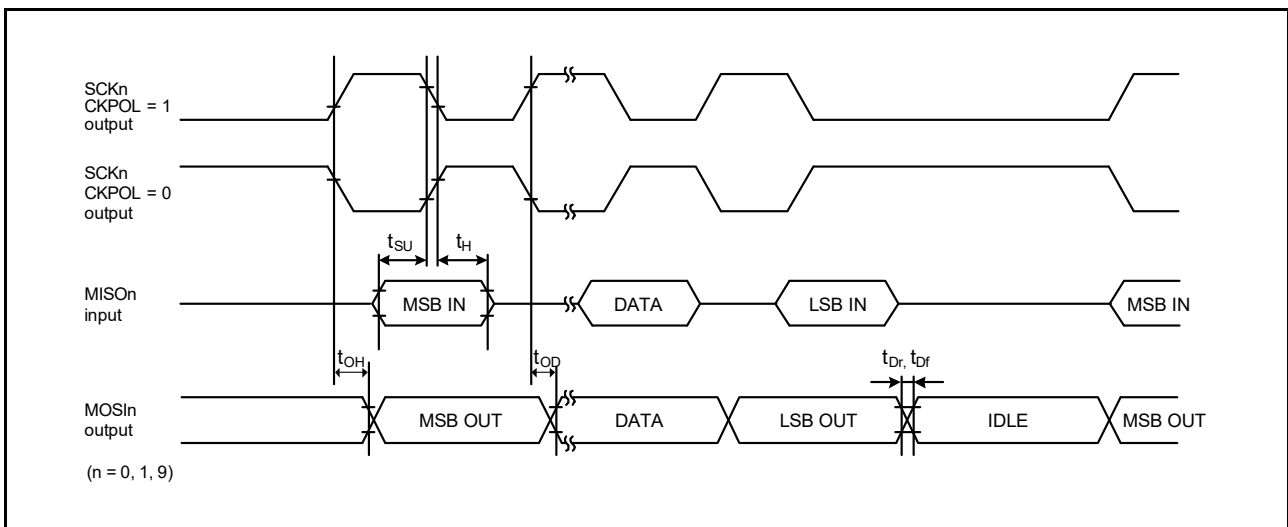

Figure 2.46 SCI simple SPI mode timing (master, CKPH = 0)

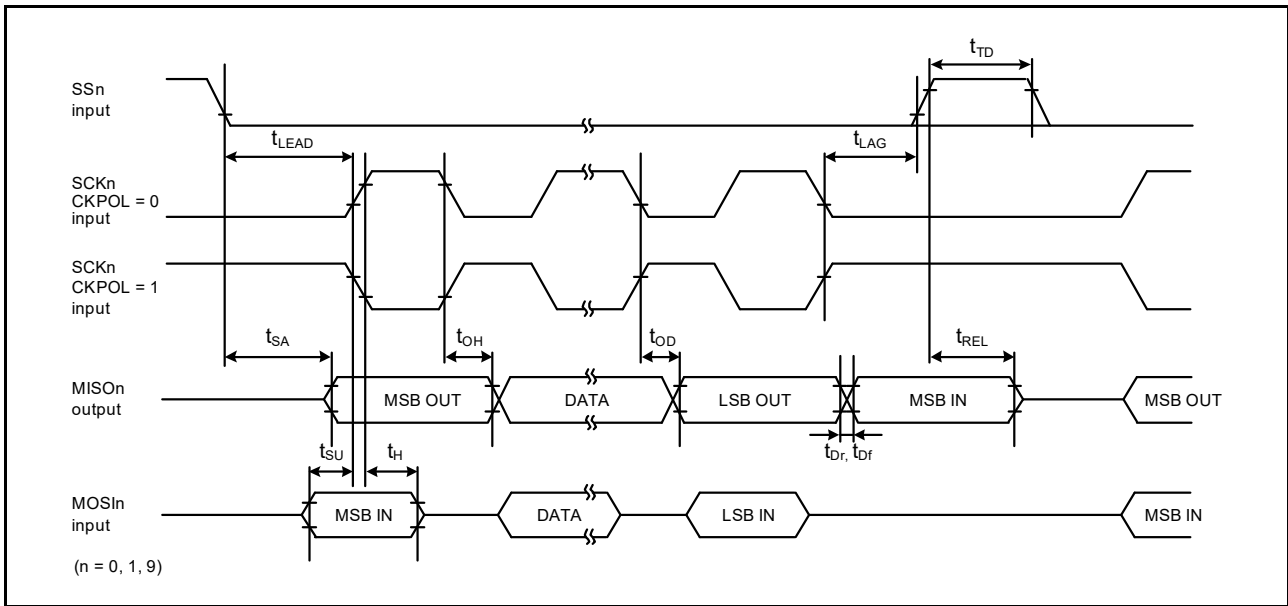

Figure 2.47 SCI simple SPI mode timing (slave, CKPH = 1)

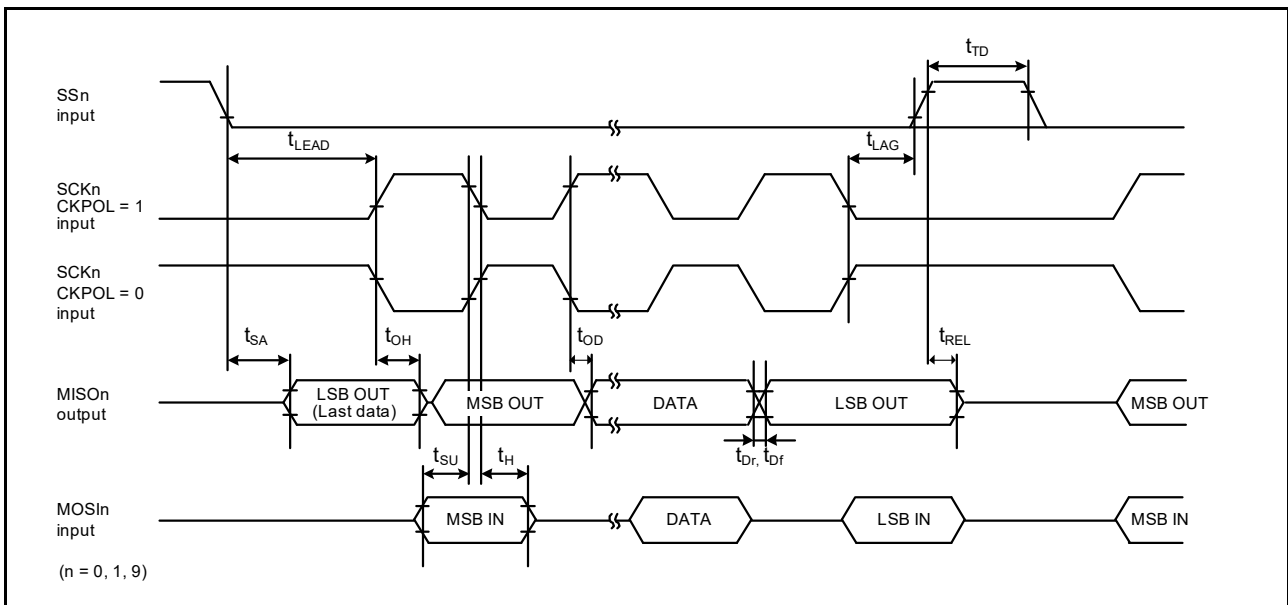

Figure 2.48 SCI simple SPI mode timing (slave, CKPH = 0)

Table 2.33 SCI timing (3)

Conditions: VCC = AVCC0 = AVCC1 = 2.7 to 5.5 V

| Parameter | Symbol | Min | Max | Unit | Test conditions | |
|----------------------------|------------------------------------|------------------------------|-----|---------------------------------------|-----------------|-------------|
| Simple IIC (Standard mode) | SDA input rise time | t _{Sr} | - | 1000 | ns | Figure 2.49 |
| | SDA input fall time | t _{Sf} | - | 300 | ns | |
| | SDA input spike pulse removal time | t _{SP} | 0 | 4 × t _{IIcCyc} ^{*1} | ns | |
| | Data input setup time | t _{SDAS} | 250 | - | ns | |
| | Data input hold time | t _{SDAH} | 0 | - | ns | |
| | SCL, SDA capacitive load | C _b ^{*2} | - | 400 | pF | |

Table 2.33 SCI timing (3)

Conditions: VCC = AVCC0 = AVCC1 = 2.7 to 5.5 V

| Parameter | Symbol | Min | Max | Unit | Test conditions | |
|------------------------|------------------------------------|------------|-----|----------------------------|-----------------|-------------|
| Simple IIC (Fast mode) | SDA input rise time | t_{Sr} | - | 300 | ns | Figure 2.49 |
| | SDA input fall time | t_{Sf} | - | 300 | ns | |
| | SDA input spike pulse removal time | t_{SP} | 0 | $4 \times t_{IICcyc}^{*1}$ | ns | |
| | Data input setup time | t_{SDAS} | 100 | - | ns | |
| | Data input hold time | t_{SDAH} | 0 | - | ns | |
| | SCL, SDA capacitive load | C_b^{*2} | - | 400 | pF | |

Note 1. t_{IICcyc} : Clock cycle selected by the SMR.CKS[1:0] bits.

Note 2. C_b indicates the total capacity of the bus line.

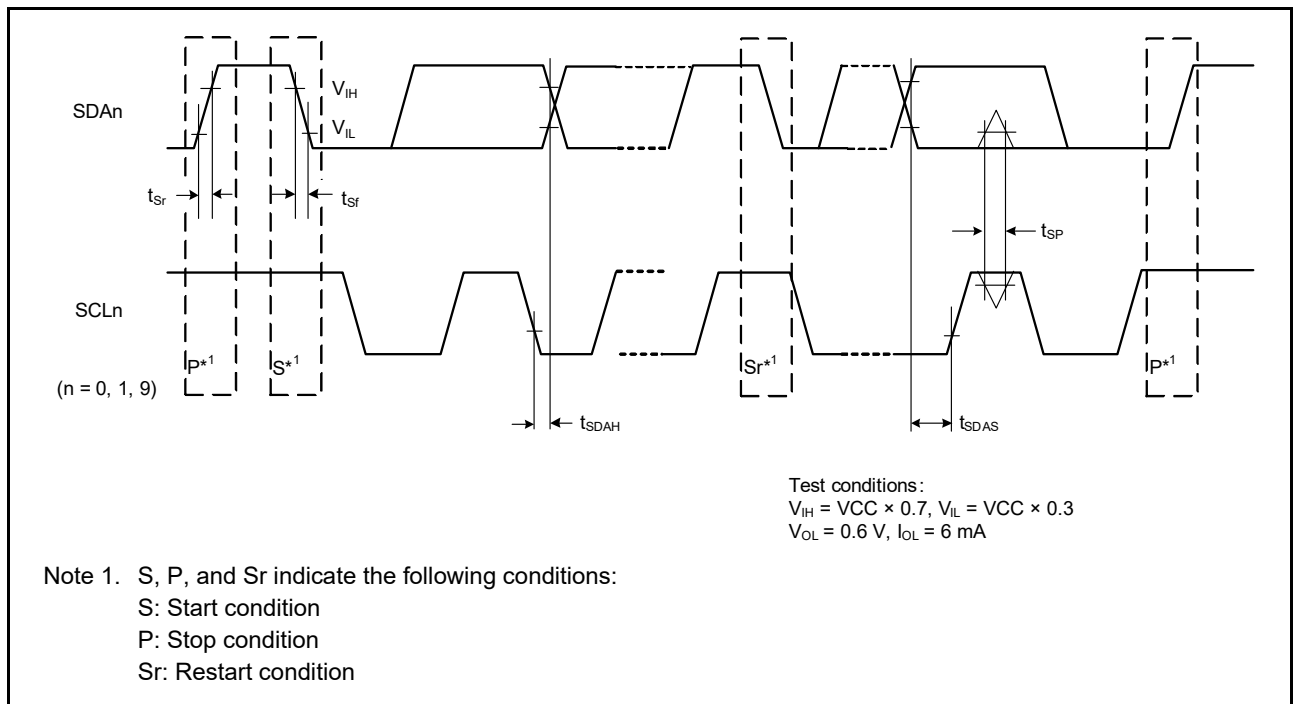

Figure 2.49 SCI simple IIC mode timing

2.3.9 SPI Timing

Table 2.34 SPI timing (1 of 2)

Conditions: Middle drive output is selected in the Port Drive Capability bit in the PmnPFS register.

| Parameter | | Symbol | Min | Max | Unit*1 | Test conditions | | |
|--------------------------------|-------------------------------|--------------|------------------------------|---|--|-----------------|--|----|
| SPI | RSPCK clock cycle | Master | t_{SPCyc} | 2 | 4096 | t_{PCyc} | Figure 2.50 C = 30 pF | |
| | | Slave | | 6 | 4096 | | | |
| RSPCK clock high pulse width | Master | t_{SPCKWH} | | $(t_{SPCyc} - t_{SPCKr} - t_{SPCKf}) / 2 - 3$ | - | ns | | |
| | Slave | | | $3 \times t_{PCyc}$ | - | | | |
| RSPCK clock low pulse width | Master | t_{SPCKWL} | | $(t_{SPCyc} - t_{SPCKr} - t_{SPCKf}) / 2 - 3$ | - | ns | | |
| | Slave | | | $3 \times t_{PCyc}$ | - | | | |
| RSPCK clock rise and fall time | Output | | t_{SPCKr} , t_{SPCKf} | $2.7 V \leq VCC \leq 5.5 V$ | - | 10 | | ns |
| | | | | $2.4 V \leq VCC < 2.7 V$ | - | 15 | | |
| | | | | $1.8 V \leq VCC \leq 2.4 V$ | - | 20 | | |
| | | | | $1.6 V \leq VCC < 1.8 V$ | - | 30 | | |
| | Input | | - | 1 | μs | | | |
| Data input setup time | Master | t_{SU} | | 10 | - | ns | Figure 2.51 to Figure 2.56 C = 30 pF | |
| | Slave | | | $2.4 V \leq VCC \leq 5.5 V$ | 10 | | | - |
| | | | | $1.8 V \leq VCC < 2.4 V$ | 15 | | | - |
| | | | | $1.6 V \leq VCC < 1.8 V$ | 20 | | | - |
| Data input hold time | Master (RSPCK is PCLKB/2) | t_{HF} | 0 | - | ns | | | |
| | Master (RSPCK is not PCLKB/2) | t_H | t_{PCyc} | - | | | | |
| | Slave | t_H | 20 | - | | | | |
| SSL setup time | Master | | t_{LEAD} | $1.8 V \leq VCC \leq 5.5 V$ | $-30 + N \times t_{SPCyc}^{*2}$ | - | | ns |
| | | | | $1.6 V \leq VCC < 1.8 V$ | $-50 + N \times t_{SPCyc}^{*2}$ | - | | |
| | Slave | | $6 \times t_{PCyc}$ | - | ns | | | |
| SSL hold time | Master | t_{LAG} | | $-30 + N \times t_{SPCyc}^{*3}$ | - | ns | | |
| | Slave | | | $6 \times t_{PCyc}$ | - | ns | | |
| Data output delay | Master | | t_{OD} | $2.7 V \leq VCC \leq 5.5 V$ | - | 14 | ns | |
| | | | | $2.4 V \leq VCC < 2.7 V$ | - | 20 | | |
| | | | | $1.8 V \leq VCC < 2.4 V$ | - | 25 | | |
| | | | | $1.6 V \leq VCC < 1.8 V$ | - | 30 | | |
| | Slave | | | $2.7 V \leq VCC \leq 5.5 V$ | - | 50 | | |
| | | | | $2.4 V \leq VCC < 2.7 V$ | - | 60 | | |
| | | | | $1.8 V \leq VCC < 2.4 V$ | - | 85 | | |
| | | | | $1.6 V \leq VCC < 1.8 V$ | - | 110 | | |
| Data output hold time | Master | t_{OH} | | 0 | - | ns | | |
| | Slave | | | 0 | - | | | |
| Successive transmission delay | Master | t_{TD} | | $t_{SPCyc} + 2 \times t_{PCyc}$ | $8 \times t_{SPCyc} + 2 \times t_{PCyc}$ | ns | | |
| | Slave | | | $6 \times t_{PCyc}$ | - | | | |

Table 2.34 SPI timing (2 of 2)

Conditions: Middle drive output is selected in the Port Drive Capability bit in the PmnPFS register.

| Parameter | | Symbol | Min | Max | Unit*1 | Test conditions | | |
|---------------------------|----------------------------------|--|--|----------------------|---------------------------|---|--|---|
| SPI | MOSI and MISO rise and fall time | Output | $2.7 \text{ V} \leq \text{VCC} \leq 5.5 \text{ V}$ | t_{Dr}, t_{Df} | - | 10 | ns Figure 2.51 to Figure 2.56 C = 30 pF | |
| | | | $2.4 \text{ V} \leq \text{VCC} < 2.7 \text{ V}$ | | - | 15 | | |
| | | | $1.8 \text{ V} \leq \text{VCC} < 2.4 \text{ V}$ | | - | 20 | | |
| | | | $1.6 \text{ V} \leq \text{VCC} < 1.8 \text{ V}$ | | - | 30 | | |
| | | Input | | | - | 1 | | μs |
| | SSL rise and fall time | Output | $2.7 \text{ V} \leq \text{VCC} \leq 5.5 \text{ V}$ | t_{SSLr}, t_{SSLf} | - | 10 | | ns Figure 2.55 and Figure 2.56 C = 30 pF |
| | | | $2.4 \text{ V} \leq \text{VCC} < 2.7 \text{ V}$ | | - | 15 | | |
| | | | $1.8 \text{ V} \leq \text{VCC} < 2.4 \text{ V}$ | | - | 20 | | |
| | | $1.6 \text{ V} \leq \text{VCC} < 1.8 \text{ V}$ | | - | 30 | | | |
| | Input | | | - | 1 | μs | | |
| Slave access time | | $2.4 \text{ V} \leq \text{VCC} \leq 5.5 \text{ V}$ | t_{SA} | - | $2 \times t_{Pcyc} + 100$ | ns Figure 2.55 and Figure 2.56 C = 30 pF | | |
| | | $1.8 \text{ V} \leq \text{VCC} < 2.4 \text{ V}$ | | - | $2 \times t_{Pcyc} + 140$ | | | |
| | | $1.6 \text{ V} \leq \text{VCC} < 1.8 \text{ V}$ | | - | $2 \times t_{Pcyc} + 180$ | | | |
| Slave output release time | | $2.4 \text{ V} \leq \text{VCC} \leq 5.5 \text{ V}$ | t_{REL} | - | $2 \times t_{Pcyc} + 100$ | | ns | |
| | | $1.8 \text{ V} \leq \text{VCC} < 2.4 \text{ V}$ | | - | $2 \times t_{Pcyc} + 140$ | | | |
| | | $1.6 \text{ V} \leq \text{VCC} < 1.8 \text{ V}$ | | - | $2 \times t_{Pcyc} + 180$ | | | |

Note 1. t_{Pcyc} : PCLKB cycle.

Note 2. N is set as an integer from 1 to 8 by the SPCKD register.

Note 3. N is set as an integer from 1 to 8 by the SSLND register.

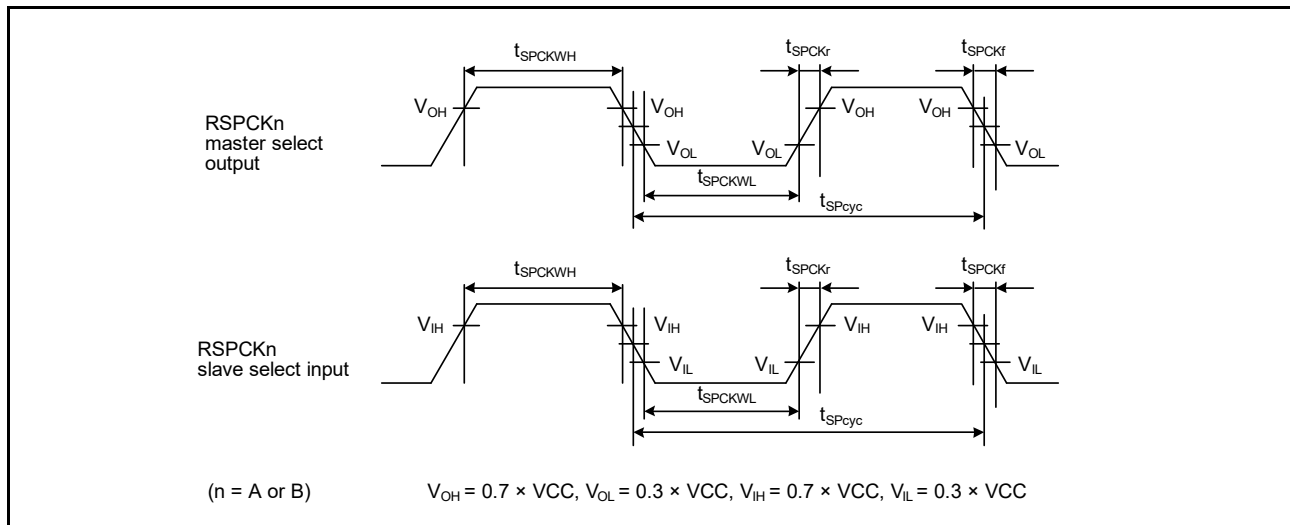
**Figure 2.50 SPI clock timing**

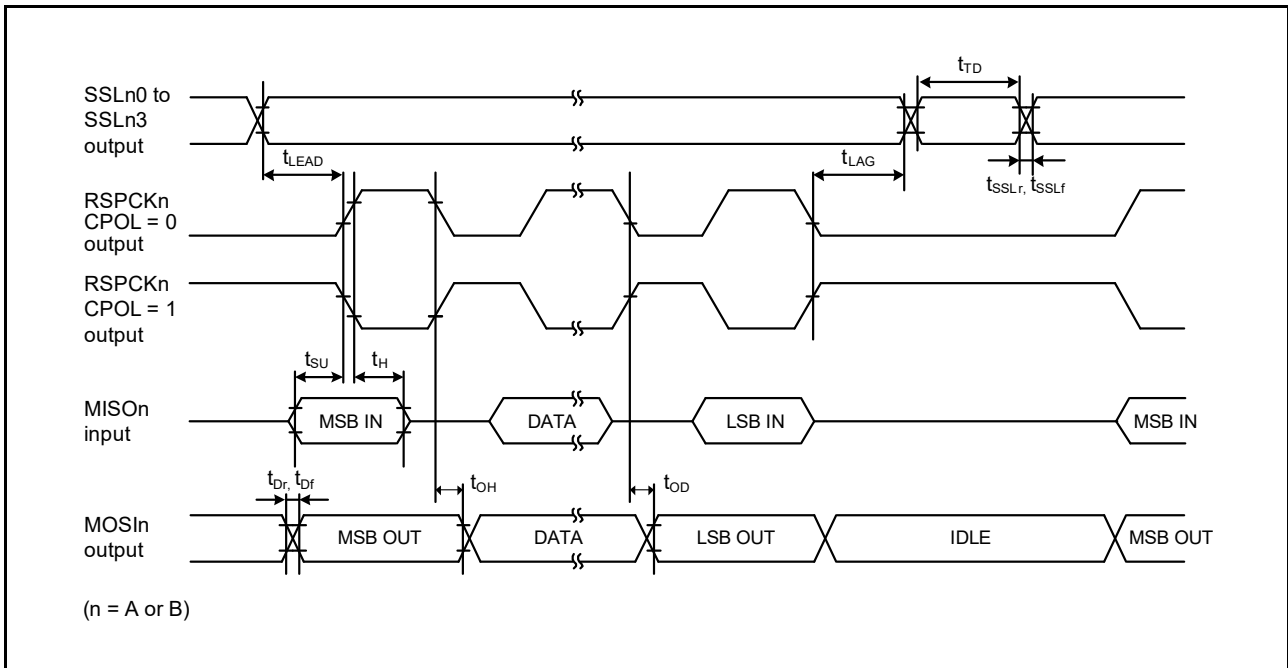

Figure 2.51 SPI timing (master, CPHA = 0) (bit rate: PCLKB division ratio is set to any value other than 1/2)

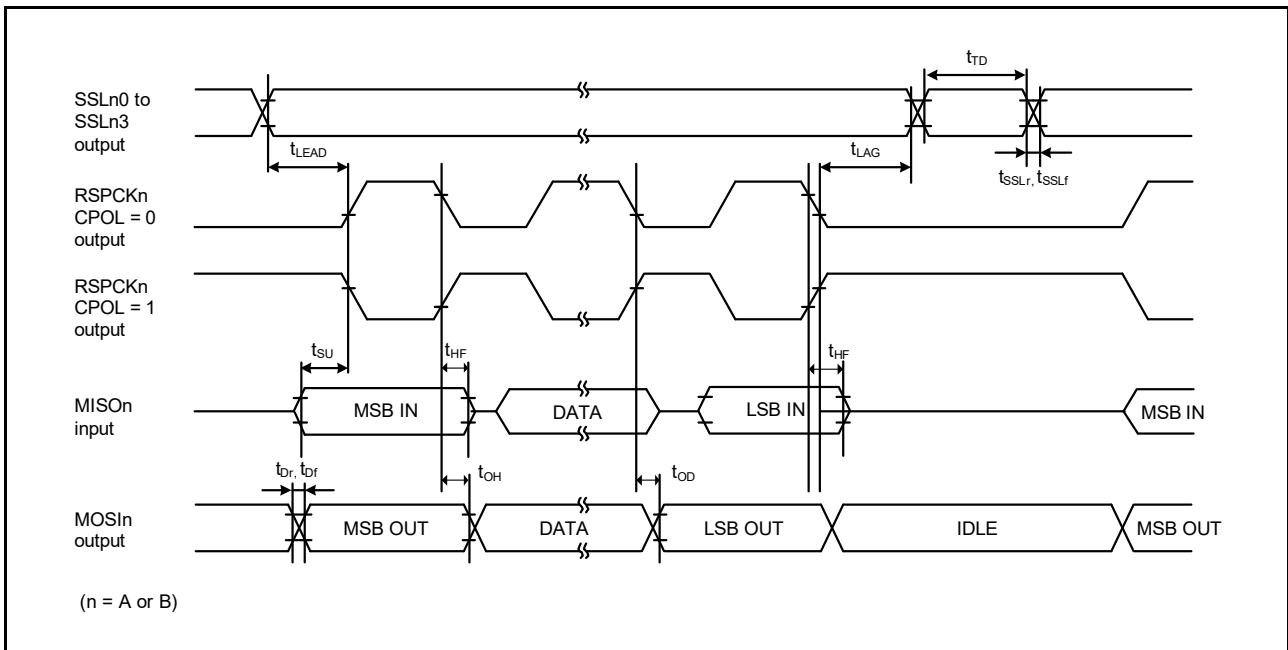

Figure 2.52 SPI timing (master, CPHA = 0) (bit rate: PCLKB division ratio is set to 1/2)

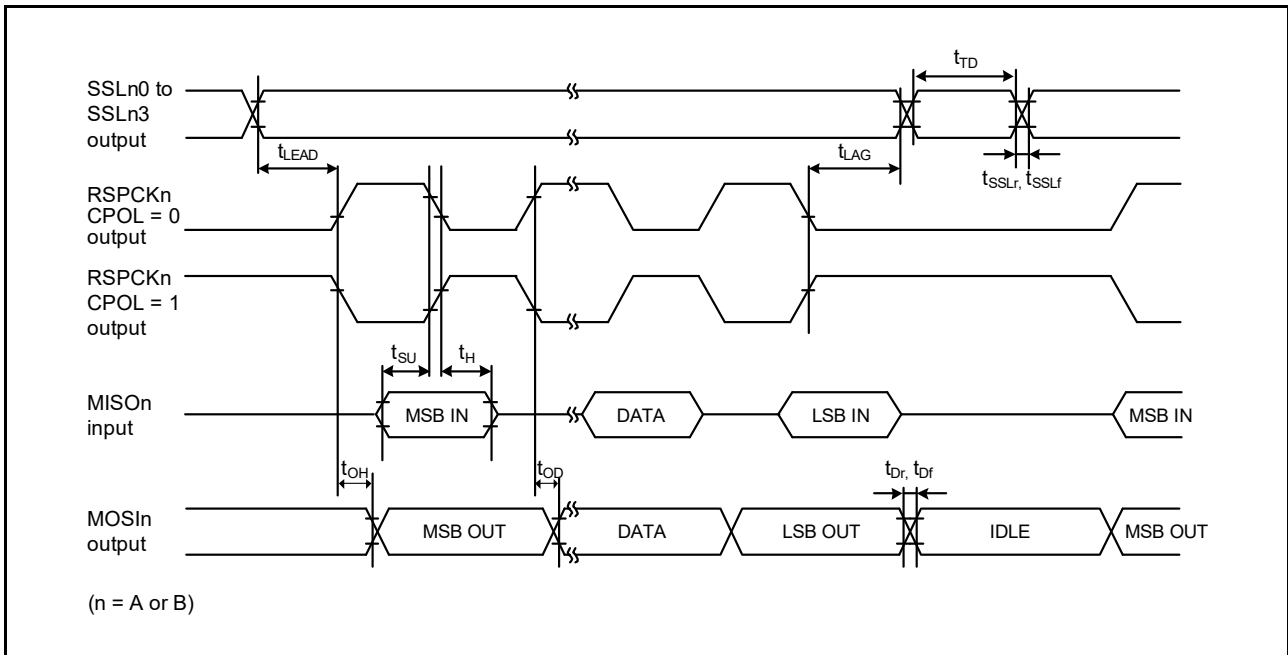

Figure 2.53 SPI timing (master, CPHA = 1) (bit rate: PCLKB division ratio is set to any value other than 1/2)

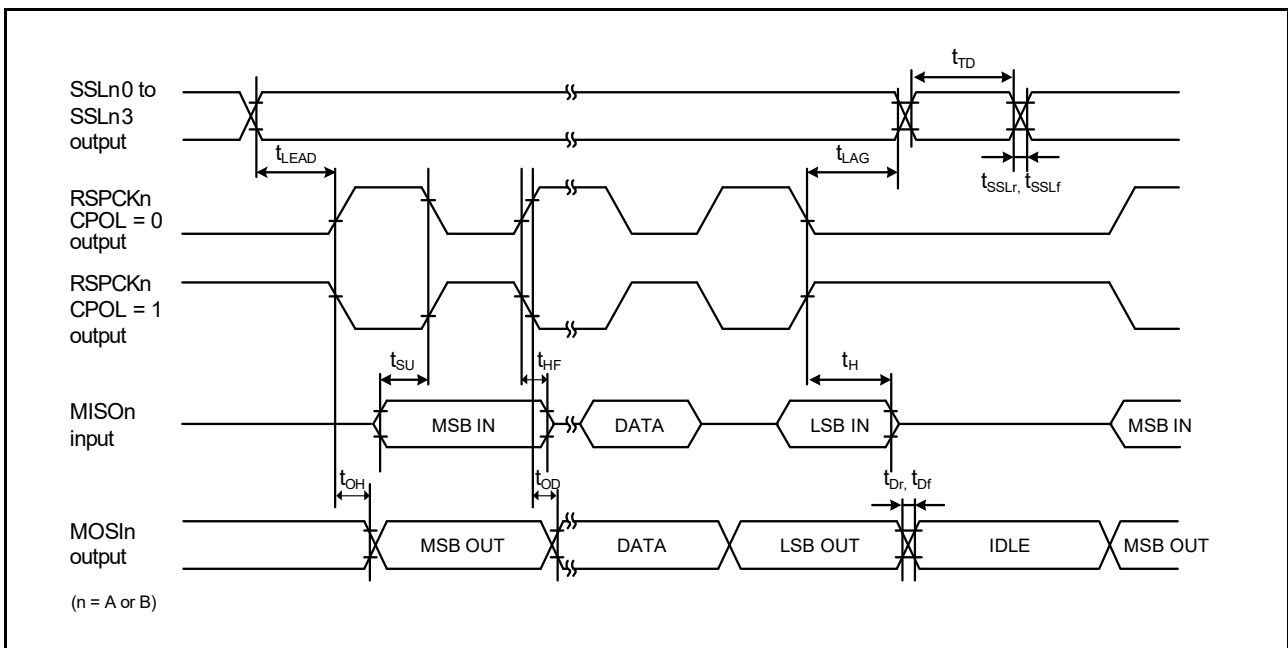

Figure 2.54 SPI timing (master, CPHA = 1) (bit rate: PCLKB division ratio is set to 1/2)

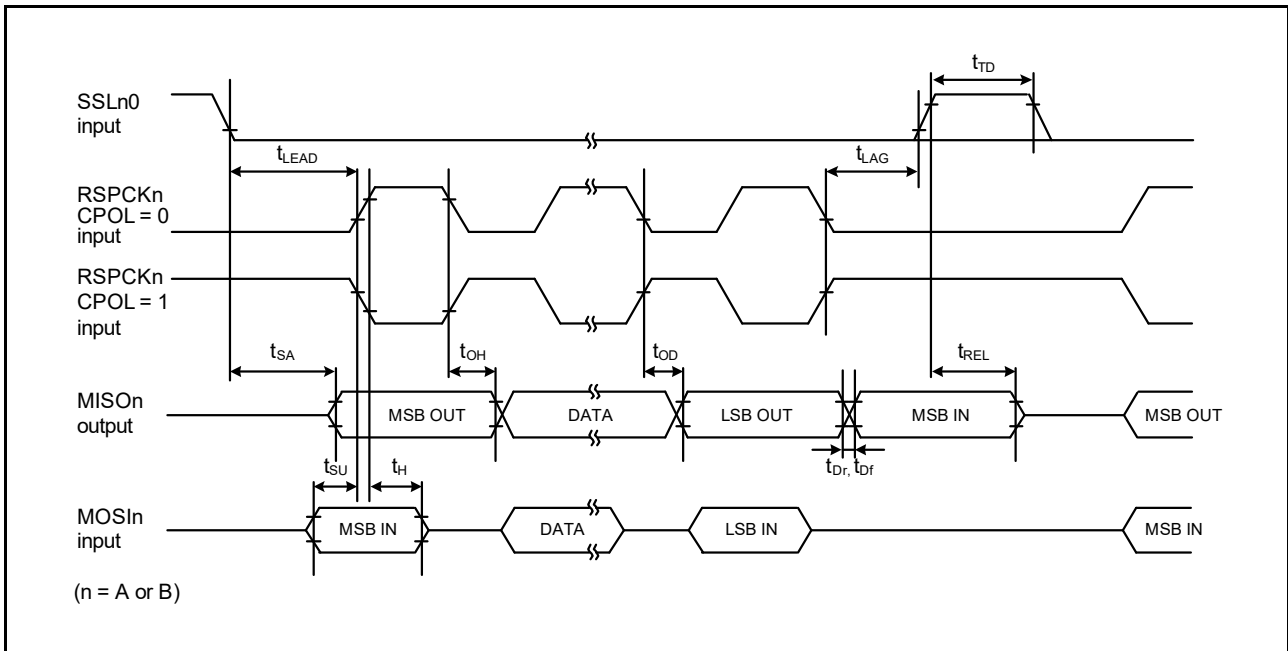

Figure 2.55 SPI timing (slave, CPHA = 0)

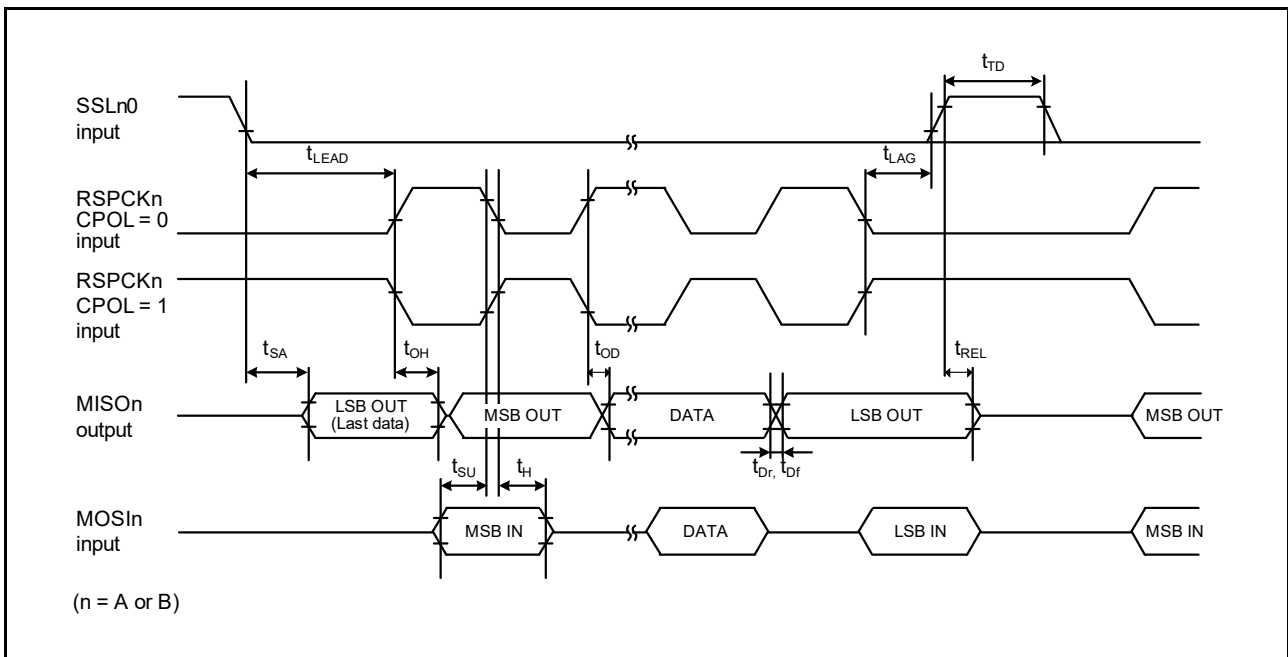

Figure 2.56 SPI timing (slave, CPHA = 1)

2.3.10 IIC Timing

Table 2.35 IIC timing

Conditions: VCC = AVCC0 = AVCC1 = 2.7 to 5.5 V

| Parameter | | Symbol | Min*1 | Max | Unit | Test conditions |
|----------------------------------|---|------------|---|---------------------------|------|-----------------|
| IIC (Standard mode, SMBus) | SCL input cycle time | t_{SCL} | $6 (12) \times t_{IICcyc} + 1300$ | - | ns | Figure 2.57 |
| | SCL input high pulse width | t_{SCLH} | $3 (6) \times t_{IICcyc} + 300$ | - | ns | |
| | SCL input low pulse width | t_{SCLL} | $3 (6) \times t_{IICcyc} + 300$ | - | ns | |
| | SCL, SDA input rise time | t_{Sr} | - | 1000 | ns | |
| | SCL, SDA input fall time | t_{Sf} | - | 300 | ns | |
| | SCL, SDA input spike pulse removal time | t_{SP} | 0 | $1 (4) \times t_{IICcyc}$ | ns | |
| | SDA input bus free time (when wakeup function is disabled) | t_{BUF} | $3 (6) \times t_{IICcyc} + 300$ | - | ns | |
| | SDA input bus free time (when wakeup function is enabled) | t_{BUF} | $3 (6) \times t_{IICcyc} + 4 \times t_{Pcyc} + 300$ | - | ns | |
| | START condition input hold time (when wakeup function is disabled) | t_{STAH} | $t_{IICcyc} + 300$ | - | ns | |
| | START condition input hold time (when wakeup function is enabled) | t_{STAH} | $1 (5) \times t_{IICcyc} + t_{Pcyc} + 300$ | - | ns | |
| | Repeated START condition input setup time | t_{STAS} | 1000 | - | ns | |
| | STOP condition input setup time | t_{STOS} | 1000 | - | ns | |
| | Data input setup time | t_{SDAS} | $t_{IICcyc} + 50$ | - | ns | |
| | Data input hold time | t_{SDAH} | 0 | - | ns | |
| | SCL, SDA capacitive load | C_b | - | 400 | pF | |
| IIC (Fast mode) | SCL input cycle time | t_{SCL} | $6 (12) \times t_{IICcyc} + 600$ | - | ns | Figure 2.57 |
| | SCL input high pulse width | t_{SCLH} | $3 (6) \times t_{IICcyc} + 300$ | - | ns | |
| | SCL input low pulse width | t_{SCLL} | $3 (6) \times t_{IICcyc} + 300$ | - | ns | |
| | SCL, SDA input rise time | t_{Sr} | - | 300 | ns | |
| | SCL, SDA input fall time | t_{Sf} | - | 300 | ns | |
| | SCL, SDA input spike pulse removal time | t_{SP} | 0 | $1 (4) \times t_{IICcyc}$ | ns | |
| | SDA input bus free time (When wakeup function is disabled) | t_{BUF} | $3 (6) \times t_{IICcyc} + 300$ | - | ns | |
| | SDA input bus free time (When wakeup function is enabled) | t_{BUF} | $3 (6) \times t_{IICcyc} + 4 \times t_{Pcyc} + 300$ | - | ns | |
| | START condition input hold time (When wakeup function is disabled) | t_{STAH} | $t_{IICcyc} + 300$ | - | ns | |
| | START condition input hold time (When wakeup function is enabled) | t_{STAH} | $1 (5) \times t_{IICcyc} + t_{Pcyc} + 300$ | - | ns | |
| | Repeated START condition input setup time | t_{STAS} | 300 | - | ns | |
| | STOP condition input setup time | t_{STOS} | 300 | - | ns | |
| | Data input setup time | t_{SDAS} | $t_{IICcyc} + 50$ | - | ns | |
| | Data input hold time | t_{SDAH} | 0 | - | ns | |
| | SCL, SDA capacitive load | C_b | - | 400 | pF | |

Note: t_{IICcyc} : IIC internal reference clock (IIC ϕ) cycle, t_{Pcyc} : PCLKB cycle

Note 1. Values in parentheses apply when ICMR3.NF[1:0] is set to 11b while the digital filter is enabled with ICFER.NFE set to 1.

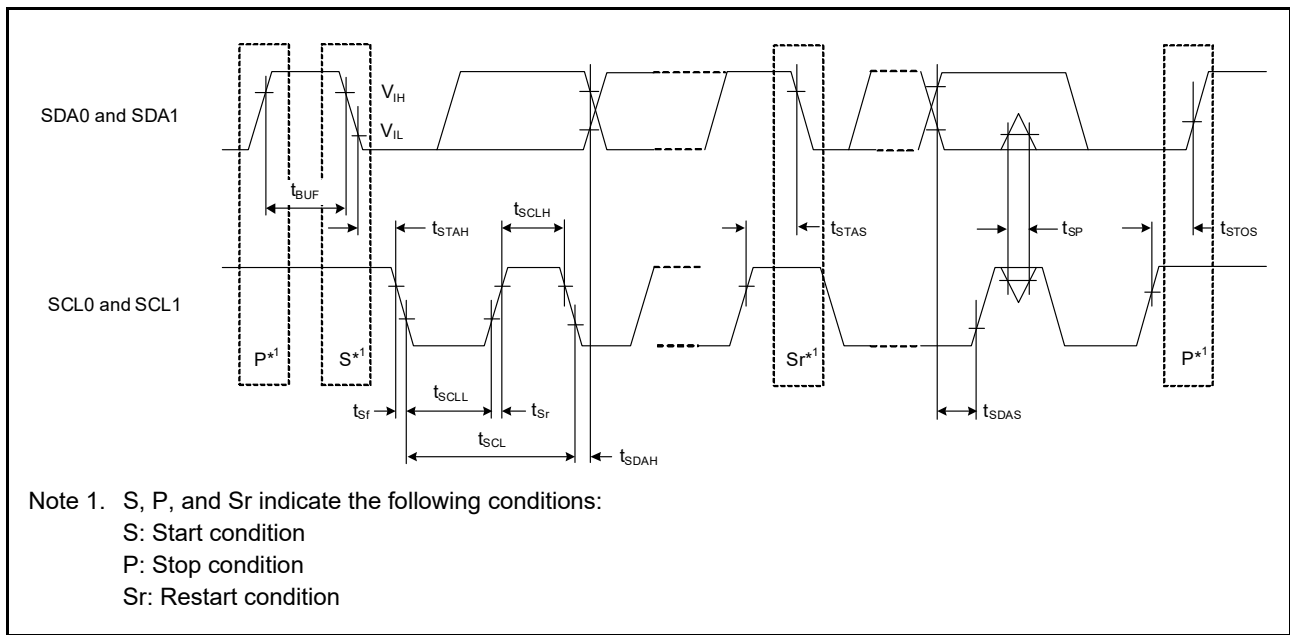

Figure 2.57 I²C bus interface input/output timing

2.3.11 CLKOUT Timing

Table 2.36 CLKOUT timing

| Parameter | Symbol | Min | Max | Unit | Test conditions | |
|-------------------------------|------------------|---------------------|------|------|-----------------|-------------|
| CLKOUT pin output cycle*1 | t _{Cyc} | 2.7 V ≤ VCC ≤ 5.5 V | 62.5 | - | ns | Figure 2.58 |
| | | 1.8 V ≤ VCC < 2.7 V | 125 | - | | |
| | | 1.6 V ≤ VCC < 1.8 V | 250 | - | | |
| CLKOUT pin high pulse width*2 | t _{CH} | 2.7 V ≤ VCC ≤ 5.5 V | 15 | - | ns | |
| | | 1.8 V ≤ VCC < 2.7 V | 30 | - | | |
| | | 1.6 V ≤ VCC < 1.8 V | 150 | - | | |
| CLKOUT pin low pulse width*2 | t _{CL} | 2.7 V ≤ VCC ≤ 5.5 V | 15 | - | ns | |
| | | 1.8 V ≤ VCC < 2.7 V | 30 | - | | |
| | | 1.6 V ≤ VCC < 1.8 V | 150 | - | | |
| CLKOUT pin output rise time | t _{Cr} | 2.7 V ≤ VCC ≤ 5.5 V | - | 12 | ns | |
| | | 1.8 V ≤ VCC < 2.7 V | - | 25 | | |
| | | 1.6 V ≤ VCC < 1.8 V | - | 50 | | |
| CLKOUT pin output fall time | t _{Cf} | 2.7 V ≤ VCC ≤ 5.5 V | - | 12 | ns | |
| | | 1.8 V ≤ VCC < 2.7 V | - | 25 | | |
| | | 1.6 V ≤ VCC < 1.8 V | - | 50 | | |

Note 1. When the EXTAL external clock input or an oscillator is used with division by 1 (the CKOCR.CKOSSEL[2:0] bits are 011b and the CKOCR.CKODIV[2:0] bits are 000b) to output from CLKOUT, specifications in Table 2.36 should be satisfied with 45% to 55% of input duty cycle.

Note 2. When MOCO is selected as the clock output source (the CKOCR.CKOSSEL[2:0] bits are 001b), set the clock output division ratio to be divided by 2 (the CKOCR.CKODIV[2:0] bits are 001b).

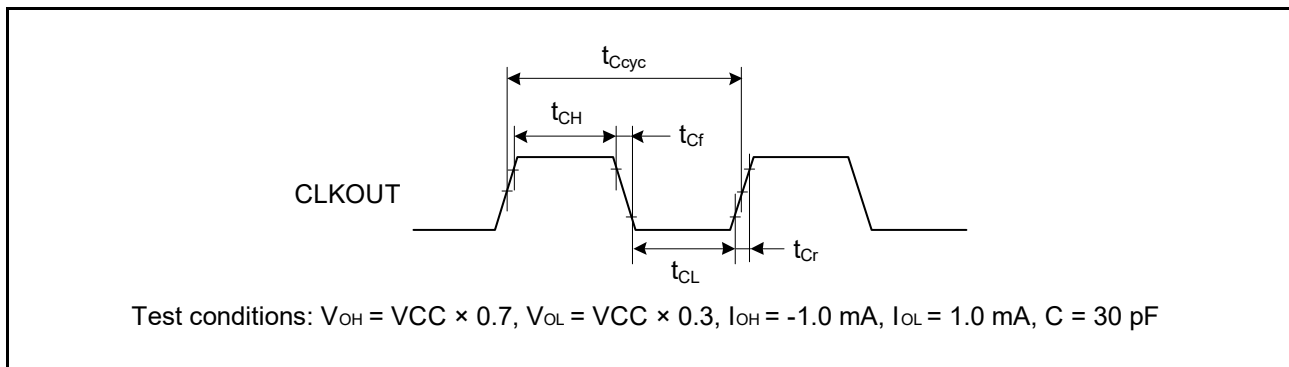

Figure 2.58 CLKOUT output timing

2.4 USB Characteristics

2.4.1 USBFS Timing

Table 2.37 USB characteristics

Conditions: $V_{CC} = AV_{CC0} = AV_{CC1} = V_{CC_USB} = 3.0 \text{ to } 3.6 \text{ V}$, $T_a = -20 \text{ to } +85^\circ\text{C}$

| Parameter | Symbol | Min | Max | Unit | Test conditions | | |
|--|--------------------------------|----------------|---------------------|---------------------|-----------------|---------------------------------------|--|
| Input characteristics | Input high level voltage | V_{IH} | 2.0 | - | V | - | |
| | Input low level voltage | V_{IL} | - | 0.8 | V | - | |
| | Differential input sensitivity | V_{DI} | 0.2 | - | V | USB_DP - USB_DM | |
| | Differential common mode range | V_{CM} | 0.8 | 2.5 | V | - | |
| Output characteristics | Output high level voltage | V_{OH} | 2.8 | V_{CC_USB} | V | $I_{OH} = -200 \mu\text{A}$ | |
| | Output low level voltage | V_{OL} | 0.0 | 0.3 | V | $I_{OL} = 2 \text{ mA}$ | |
| | Cross-over voltage | V_{CRS} | 1.3 | 2.0 | V | Figure 2.59, Figure 2.60, Figure 2.61 | |
| | Rise time | FS | t_r | 4 | 20 | ns | (Adjusting the resistance of external elements is not required.) |
| | | LS | | 75 | 300 | | |
| | Fall time | FS | t_f | 4 | 20 | ns | |
| | | LS | | 75 | 300 | | |
| | Rise/fall time ratio | FS | t_r/t_f | 90 | 111.11 | % | |
| LS | | | 80 | 125 | | | |
| Output resistance | Z_{DRV} | 28 | 44 | Ω | | | |
| VBUS characteristics | VBUS input voltage | V_{IH} | $V_{CC} \times 0.8$ | - | V | - | |
| | | V_{IL} | - | $V_{CC} \times 0.2$ | V | - | |
| Pull-up, pull-down | Pull-down resistor | R_{PD} | 14.25 | 24.80 | k Ω | - | |
| | Pull-up resistor | R_{PUI} | 0.9 | 1.575 | k Ω | During idle state | |
| | | R_{PUA} | 1.425 | 3.09 | k Ω | During reception | |
| Battery charging specification version 1.2 | D+ sink current | I_{DP_SINK} | 25 | 175 | μA | - | |
| | D- sink current | I_{DM_SINK} | 25 | 175 | μA | - | |
| | DCD source current | I_{DP_SRC} | 7 | 13 | μA | - | |
| | Data detection voltage | V_{DAT_REF} | 0.25 | 0.4 | V | - | |
| | D+ source voltage | V_{DP_SRC} | 0.5 | 0.7 | V | Output current = 250 μA | |
| | D- source voltage | V_{DM_SRC} | 0.5 | 0.7 | V | Output current = 250 μA | |

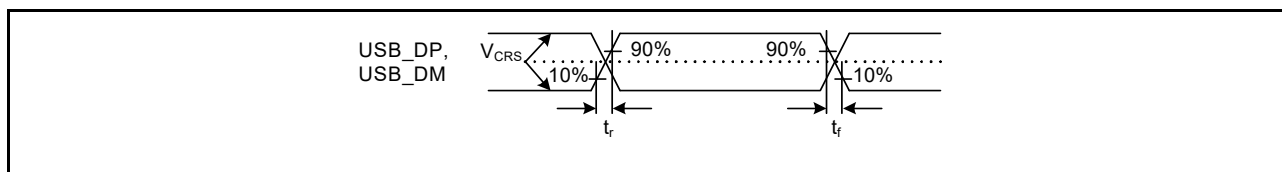

Figure 2.59 USB_DP and USB_DM output timing

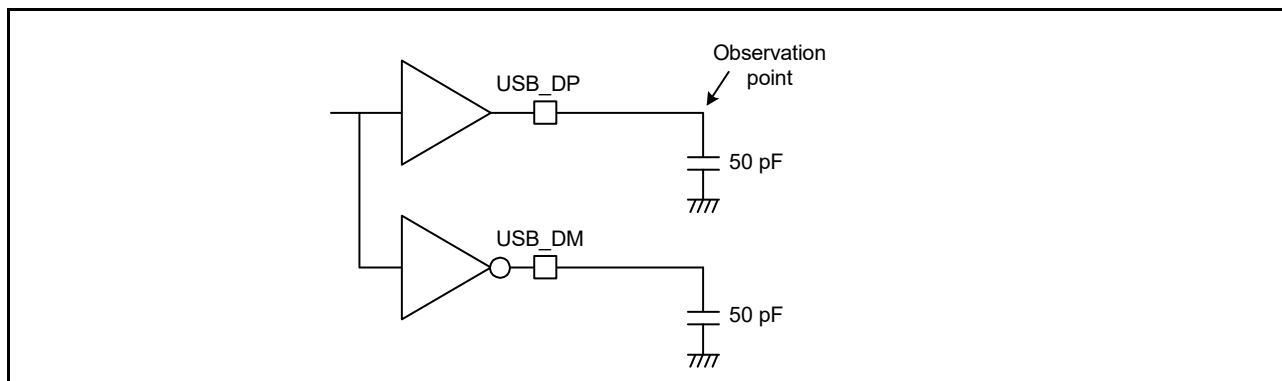

Figure 2.60 Test circuit for Full-Speed (FS) connection

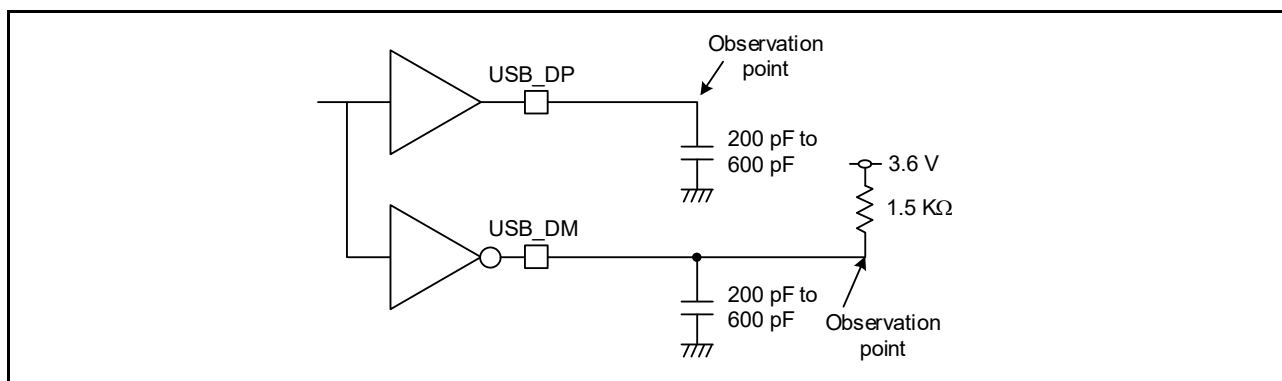

Figure 2.61 Test circuit for Low-Speed (LS) connection

2.4.2 USB External Supply

Table 2.38 USB regulator

| Parameter | | Min | Typ | Max | Unit | Test conditions |
|------------------------|--|-----|-----|-----|------|-----------------|
| VCC_USB supply current | $3.8\text{ V} \leq \text{VCC_USB_LDO} < 4.5\text{ V}$ | - | - | 50 | mA | - |
| | $4.5\text{ V} \leq \text{VCC_USB_LDO} \leq 5.5\text{ V}$ | - | - | 100 | mA | - |
| VCC_USB supply voltage | | 3.0 | - | 3.6 | V | - |

2.5 ADC16 Characteristics

Table 2.39 16-bit A/D conversion, power supply, and input range conditions

Conditions: $V_{CC} = AV_{CC0} = AV_{CC1} = 1.7$ to 5.5 V, $V_{REFH0} = 1.7$ to 5.5 V, $V_{SS} = AV_{SS0} = AV_{SS1} = V_{REFL0} = 0$ V
Reference voltage range applied to the V_{REFH0} and V_{REFL0} .

| Parameter | Min | Typ | Max | Unit | Test conditions | |
|----------------------------------|-----|------------|---------------|-------------|-----------------|--|
| High-potential reference voltage | 1.5 | 3.3 | AV_{CC0} | V | - | |
| Low-potential reference voltage | - | AV_{SS0} | - | V | - | |
| Analog input voltage range | 0 | - | V_{REFH0} | V | - | |
| Input common-mode range | Acm | 0 | $V_{REFH0}/2$ | V_{REFH0} | V | Differential analog input |
| Analog input capacitance*2 | Cs | - | - | 4.3 | pF | - |
| Analog input resistance*1 | Rs | - | - | 0.7 | k Ω | High-precision channel 2.7 V $\leq AV_{CC0} \leq 5.5$ V |
| | | - | - | 1.5 | | High-precision channel 1.7 V $\leq AV_{CC0} < 2.7$ V |
| | | - | - | 2.5 | | Normal-precision channel 2.7 V $\leq AV_{CC0} \leq 5.5$ V |
| | | - | - | 3.8 | | Normal-precision channel 1.7 V $\leq AV_{CC0} < 2.7$ V |

Note 1. These values are based on simulation. They are not production tested.

Note 2. Except for I/O input capacitance (C_{in}), see [section 2.2.4, I/O VOH, VOL, and Other Characteristics](#).

Figure 2.62 shows the equivalent circuit for analog input.

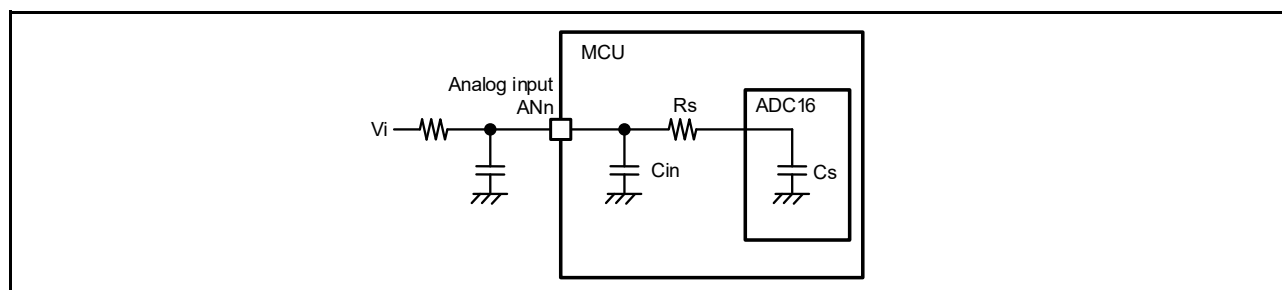

Figure 2.62 Equivalent circuit for analog input

Table 2.40 16-bit A/D conversion, timing parameters (1 of 2)

Conditions: $V_{CC} = AV_{CC0} = AV_{CC1} = 1.7$ to 5.5 V, $V_{REFH0} = 1.7$ to 5.5 V, $V_{SS} = AV_{SS0} = AV_{SS1} = V_{REFL0} = 0$ V
Reference voltage range applied to the V_{REFH0} and V_{REFL0} .

| Parameter | Symbol | Min | Typ | Max | Unit | Test conditions |
|-----------------|--------|-----|-----|------------------------------|------|---|
| Frequency | ADCLK | 1 | - | 32 | MHz | 3.0 V $\leq AV_{CC0} \leq 5.5$ V, 3.0 V $\leq V_{REFH0}$ |
| | | 1 | - | 24 | | 2.7 V $\leq AV_{CC0} \leq 5.5$ V, 2.7 V $\leq V_{REFH0}$ |
| | | 1 | - | 16 | | 2.4 V $\leq AV_{CC0} \leq 5.5$ V, 1.5 V $\leq V_{REFH0}$ |
| | | 1 | - | 8 | | 1.8 V $\leq AV_{CC0} \leq 5.5$ V, 1.5 V $\leq V_{REFH0}$ |
| | | 1 | - | 4 | | 1.7 V $\leq AV_{CC0} \leq 5.5$ V, 1.5 V $\leq V_{REFH0}$ |
| Conversion rate | F_s | - | - | $1 / (t_{SPL} + 18 / ADCLK)$ | S/s | - |

Table 2.40 16-bit A/D conversion, timing parameters (2 of 2)

Conditions: VCC = AVCC0 = AVCC1 = 1.7 to 5.5 V, VREFH0 = 1.7 to 5.5 V, VSS = AVSS0 = AVSS1 = VREFL0 = 0 V
Reference voltage range applied to the VREFH0 and VREFL0.

| Parameter | Symbol | Min | Typ | Max | Unit | Test conditions |
|--|--------|------|-----|-----|------|---|
| Sampling time*1 Permissible signal source impedance Max = 0.5 kΩ | tsPL | 0.25 | - | - | μs | High-precision channel 2.7 V ≤ AVCC0 ≤ 5.5 V |
| | | 3 | - | - | | High-precision channel 1.7 V ≤ AVCC0 < 2.7 V |
| | | 3 | - | - | | Normal-precision channel 2.7 V ≤ AVCC0 ≤ 5.5 V |
| | | 10 | - | - | | Normal-precision channel 1.7 V ≤ AVCC0 < 2.7 V |
| Settling time*1 | tSTART | - | - | 1 | μs | 2.7 V ≤ AVCC0 ≤ 5.5 V |
| | | - | - | 3.2 | | 1.8 V ≤ AVCC0 < 2.7 V |
| | | - | - | 8.9 | | 1.7 V ≤ AVCC0 < 1.8 V |

Note 1. These values are based on simulation. They are not production tested.

Table 2.41 16-bit A/D conversion, linearity parameters

Conditions: VCC = AVCC0 = AVCC1 = 1.7 to 5.5 V, VREFH0 = 1.7 to 5.5 V, VSS = AVSS0 = AVSS1 = VREFL0 = 0 V
External clock input used. Reference voltage range applied to the VREFH0 and VREFL0.

| Parameter | Symbol | Min | Typ | Max | Unit | Test conditions |
|------------------------------|--------|-----|----------|------|------|---------------------------------------|
| Resolution | - | - | 16 | - | Bit | - |
| Integral non-linearity *1 | INL | - | ± 4 | ± 8 | LSB | 2.7 V ≤ AVCC0 ≤ 5.5 V, 2.7 V ≤ VREFH0 |
| | | - | - | ± 16 | | 1.7 V ≤ AVCC0 < 2.7 V |
| Differential non-linearity*1 | DNL | - | -1 to +2 | - | LSB | - |
| Offset error*1 | Ofst | - | ± 4 | - | LSB | - |
| Gain error*1 | Gerr | - | - | ±0.1 | % | 2.7 V ≤ VREFH0 |

Note: The characteristics apply when no pin functions other than 16-bit A/D converter input are used. Offset error, full-scale error, DNL differential non-linearity error, and INL integral non-linearity error do not include quantization errors.

Note 1. These values are based on simulation. They are not production tested.

Table 2.42 16-bit A/D conversion, dynamic parameters (1) (1 of 2)

Conditions: VCC = AVCC0 = AVCC1 = 1.7 to 5.5 V, VREFH0 = 1.7 to 5.5 V, VSS = AVSS0 = AVSS1 = VREFL0 = 0 V
External clock input used. Reference voltage range applied to VREFH0 and VREFL0.

| Parameter | Symbol | Min | Typ | Max | Unit | Test conditions |
|----------------------------------|--------|-----|-----|-----|------|--|
| Signal-to-noise and distortion*2 | SINAD | 67 | 81 | - | dB | Differential input, Fin = 1 kHz, VREFH0 = 1.7 V to 5.5 V, AVCC0 = 1.7 V to 5.5 V |
| | | 78 | 81 | - | | Differential input, Fin = 1 kHz, VREFH0 = 3.3 V, AVCC0 = 3.3 V |
| | | - | 92 | - | | Differential input, Fin = 1 kHz, VREFH0 = 3.3 V, AVCC0 = 3.3 V, ADADC.ADC[2:0] = 101b |
| | | 61 | 75 | - | | Single input, Fin = 1 kHz, VREFH0 = 1.7 V to 5.5 V, AVCC0 = 1.7 V to 5.5 V |
| | | 72 | 75 | - | | Single input, Fin = 1 kHz, VREFH0 = 3.3 V, AVCC0 = 3.3 V |

Table 2.42 16-bit A/D conversion, dynamic parameters (1) (2 of 2)

Conditions: VCC = AVCC0 = AVCC1 = 1.7 to 5.5 V, VREFH0 = 1.7 to 5.5 V, VSS = AVSS0 = AVSS1 = VREFL0 = 0 V
External clock input used. Reference voltage range applied to VREFH0 and VREFL0.

| Parameter | Symbol | Min | Typ | Max | Unit | Test conditions |
|---------------------------------|--------|------|------|-----|------|--|
| Effective number of bits*2 | ENOB | 11 | 13.2 | - | bit | Differential input, Fin = 1 kHz, VREFH0 = 1.7 V to 5.5 V, AVCC0 = 1.7 V to 5.5 V |
| | | 12.7 | 13.2 | - | | Differential input, Fin = 1 kHz, VREFH0 = 3.3 V, AVCC0 = 3.3 V |
| | | - | 15 | - | | Differential input, Fin = 1 kHz, VREFH0 = 3.3 V, AVCC0 = 3.3 V, ADADC.ADC[2:0] = 101b |
| | | 10 | 12.2 | - | | Single input, Fin = 1 kHz, VREFH0 = 1.7 V to 5.5 V, AVCC0 = 1.7 V to 5.5 V |
| | | 11.7 | 12.2 | - | | Single input, Fin = 1 kHz, VREFH0 = 3.3 V, AVCC0 = 3.3 V |
| Total harmonic distortion*1, *2 | THD | - | -100 | - | dB | Differential input, Fin = 1 kHz, AVCC0 = 3.3 V |
| | | - | -90 | - | | Single input, Fin = 1 kHz, AVCC0 = 3.3 V |
| Common mode rejection ratio*2 | CMRR | - | 100 | - | dB | Differential input, Acm = 0 to VREFH0 at 1 kHz, AVCC0 = 3.3 V |

Note: The characteristics apply when no pin functions other than 16-bit A/D converter input are used.

Note 1. THD = HD2 + HD3 + HD4 + HD5.

Note 2. These values are based on simulation. They are not production tested.

Table 2.43 16-bit A/D conversion, dynamic parameters (2)

Conditions: VCC = AVCC0 = AVCC1 = 1.7 to 5.5 V, VSS = AVSS0 = AVSS1 = VREFL0 = 0 V
External clock input used.

| Parameter | Symbol | Min | Typ | Max | Unit | Test conditions |
|----------------------------------|--------|-----|------|-----|------|--|
| Signal-to-noise and distortion*1 | SINAD | - | 78.6 | - | dB | Differential input, Fin = 1 kHz, AVCC0 = 3.3 V, VREFADC output = 2.5 V |
| | | - | 76.6 | - | | Differential input, Fin = 1 kHz, AVCC0 = 3.3 V, VREFADC output = 2.0 V |
| | | - | 74.2 | - | | Differential input, Fin = 1 kHz, AVCC0 = 3.3 V, VREFADC output = 1.5 V |
| Effective number of bits*1 | ENOB | - | 12.8 | - | bit | Differential input, Fin = 1 kHz, AVCC0 = 3.3 V, VREFADC output = 2.5 V |
| | | - | 12.4 | - | | Differential input, Fin = 1 kHz, AVCC0 = 3.3 V, VREFADC output = 2.0 V |
| | | - | 12.0 | - | | Differential input, Fin = 1 kHz, AVCC0 = 3.3 V, VREFADC output = 1.5 V |

Note: The characteristics apply when no pin functions other than 16-bit A/D converter input are used.

Note 1. These values are based on simulation. They are not production tested.

Table 2.44 16-bit A/D converter channel classification

| Classification | Channel | Conditions |
|--|----------------------------|----------------------|
| High-precision channel | AN000 to AN008 | AVCC0 = 1.7 to 5.5 V |
| Normal-precision channel | AN016 to AN023 | |
| Internal reference voltage input channel | Internal reference voltage | AVCC0 = 2.0 to 5.5 V |
| Temperature sensor input channel | Temperature sensor output | AVCC0 = 2.0 to 5.5 V |

Table 2.45 Internal reference voltage for 16-bit ADC (VREFADC) characteristics

Conditions: VCC = AVCC0 = AVCC1 = 1.7 V to 5.5 V, VSS = AVSS0 = AVSS1 = VREFL0 = 0 V

| Parameter | Min | Typ | Max | Unit | Test conditions |
|--|------|-----|------|------|---|
| Output voltage range | 1.41 | 1.5 | 1.59 | V | VREFAMPCNT.VREFADCG[1:0] = 00b AVCC0 ≥ 1.7 V |
| | 1.88 | 2 | 2.12 | | VREFAMPCNT.VREFADCG[1:0] = 10b AVCC0 ≥ 2.2 V |
| | 2.35 | 2.5 | 2.65 | | VREFAMPCNT.VREFADCG[1:0] = 11b AVCC0 ≥ 2.7 V |
| BGR stabilization time*2 (after BGR is enabled) | - | - | 150 | μs | VREFAMPCNT.BGREN = 1 |
| VREF AMP stabilization time*2 (after VREFAMP is enabled) | - | - | 1500 | μs | VREFAMPCNT.VREFADCEN = 1 |
| Detect over current*2 | - | 20 | 40 | mA | - |
| Load capacitance*1 | 0.75 | 1 | 1.25 | μF | - |

Note 1. Connect capacitors as stabilization capacitance between the VREFH0 and VREFL0 pins when VREFADC is used.

Note 2. These values are based on simulation. They are not production tested.

Table 2.46 A/D internal reference voltage characteristics

Conditions: VCC = AVCC0 = AVCC1 = VREFH0 = 2.0 to 5.5 V*1

| Parameter | Min | Typ | Max | Unit | Test conditions |
|--|------|------|------|------|-----------------|
| Internal reference voltage input channel*2 | 1.36 | 1.43 | 1.50 | V | - |
| Sampling time*3 | 5.0 | - | - | μs | - |

Note 1. The internal reference voltage cannot be selected for input channels when AVCC0 < 2.0 V.

Note 2. The 16-bit A/D internal reference voltage indicates the voltage when the internal reference voltage is input to the 16-bit A/D converter.

Note 3. This is a parameter for ADC16 when the internal reference voltage is selected for an analog input channel in ADC16.

2.6 SDADC24 Characteristics

Table 2.47 Analog inputs characteristics (1 of 2)

Conditions: VCC = AVCC0 = AVCC1 = 2.7 to 5.5 V, VSS = AVSS0 = AVSS1 = 0 V

| Parameter | Symbol | Min | Typ | Max | Unit | Test conditions | |
|---|----------------------------------|------------------|---|-----|---|-----------------|---|
| Full-scale range | F _{SR} | - | ± 0.8 / G _{TOTAL} | - | V | - | |
| Analog input in differential input mode | Differential input voltage range | V _{ID} | -0.8 / G _{TOTAL} | - | 0.8 / G _{TOTAL} | V | V _{ID} = ANSDnP - ANSDnN, or AMP0O - AMP1O (n = 0 to 3), d _{OFR} = 0 mV |
| | Input voltage range | V _I | 0.2 | - | 1.8 | V | V _I = ANSDnP, ANSDnN, AMP0O, or AMP1O (n = 0 to 3) |
| | Common mode Input voltage range | V _{COM} | 0.2 + (V _{ID} × G _{SET1}) / 2 | 1.0 | 1.8 - (V _{ID} × G _{SET1}) / 2 | V | d _{OFR} = 0 mV |

Table 2.47 Analog inputs characteristics (2 of 2)

Conditions: VCC = AVCC0 = AVCC1 = 2.7 to 5.5 V, VSS = AVSS0 = AVSS1 = 0 V

| Parameter | | Symbol | Min | Typ | Max | Unit | Test conditions |
|---|-----------------------|--------|-----|-----|-----|------|---|
| Analog Input in single-ended input mode | Input voltage range*1 | V_I | 0.2 | - | 1.8 | V | $V_I = \text{ANSdnP, ANSDnN, AMP0O, or AMP1O}$ (n = 0 to 3), $V_{\text{COM}} = 1.0 \text{ V}$, $d_{\text{OFR}} = 0 \text{ mV}$, $G_{\text{SET1}} = 1, G_{\text{SET2}} = 1$, OSR = 256 |

Note 1. The single-ended input mode supports only $d_{\text{OFR}} = 0 \text{ mV}$, $G_{\text{SET1}} = 1$, $G_{\text{SET2}} = 1$ and OSR = 256.**Table 2.48 Programmable gain instrumentation amplifier and sigma-delta A/D converter (1)**

Conditions: VCC = AVCC0 = AVCC1 = 2.7 to 5.5 V, VSS = AVSS0 = AVSS1 = 0 V

| Parameter | | Symbol | Min | Typ | Max | Unit | Test conditions |
|-------------------------|-------------------------------|--------------------|-----------------------------|------------------------------|-----------------------------|-------|---|
| Resolution | | RES | - | 24 | - | bits | - |
| Over sampling frequency | Normal A/D conversion mode | F_{OS} | - | 1 | - | MHz | - |
| | Low-power A/D conversion mode | | - | 0.125 | - | | |
| Output data rate | | f_{DATA1} | 0.48828 | - | 15.625 | ksp/s | Normal A/D conversion mode |
| | | f_{DATA2} | 61.03615 | - | 1953.125 | sps | Low-power A/D conversion mode |
| Gain Setting range | | G_{TOTAL} | 1 | - | 32 | V/V | $G_{\text{TOTAL}} = G_{\text{SET1}} \times G_{\text{SET2}}$ |
| 1st Gain Setting range | | G_{SET1} | - | 1, 2, 3, 4, 8 | - | V/V | - |
| 2nd Gain Setting range | | G_{SET2} | - | 1, 2, 4, 8 | - | V/V | - |
| Offset adjust bit range | | d_{OFB} | - | 5 | - | bits | - |
| Offset adjust range | | d_{OFR} | $-164.06 / G_{\text{SET1}}$ | - | $+164.06 / G_{\text{SET1}}$ | mV | Referred to input |
| Offset adjust step | | d_{OFS} | - | $350 / 32 / G_{\text{SET1}}$ | - | mV | Referred to input |

Table 2.49 Programmable gain instrumentation amplifier and sigma-delta A/D converter (2)

Conditions: VCC = AVCC0 = AVCC1 = 2.7 to 5.5 V, VSS = AVSS0 = AVSS1 = 0 V

The electrical specifications are applied at differential input mode, external clock input used, $F_{\text{OS}} = 1 \text{ MHz}$, $d_{\text{OFR}} = 0 \text{ mV}$, unless otherwise specified.

| Parameter | Symbol | Min | Typ | Max | Unit | Test conditions | |
|--|--------|-----|-----|-----|------|--|---------------------------------------|
| Signal to Noise Ratio*1,*3 $V_{\text{ID}} = 0 \text{ V}$ | SNR | 83 | 86 | - | dB | $G_{\text{SET1}} = 1$, $G_{\text{SET2}} = 1$ | OSR = 256 |
| | | 81 | 84 | - | dB | $G_{\text{SET1}} = 8$, $G_{\text{SET2}} = 4$ | OSR = 1024 |
| Signal to Noise and Distortion Ratio*1, *2,*3 $f_{\text{in}} = 50 \text{ Hz}$ | SINAD | 82 | 85 | - | dB | $G_{\text{SET1}} = 1$, $G_{\text{SET2}} = 1$ | OSR = 256 |
| | | 79 | 82 | - | dB | $G_{\text{SET1}} = 8$, $G_{\text{SET2}} = 4$ | OSR = 1024 |
| | | 74 | 80 | - | dB | $G_{\text{SET1}} = 1$, $G_{\text{SET2}} = 1$ | OSR = 256, Single-ended input mode |

Note: The characteristics apply when no pin functions other than 24-bit sigma-delta A/D converter input are used.

Note 1. SNR and SINAD are the ratio to Full-Scale Range (FSR) of analog inputs. These do not include the noise of analog inputs.

Note 2. When V_{ID} is equal to $\pm 0.8 / G_{\text{TOTAL}}$ actually, the digital output may overflow due to Gain Error (E_G), Offset Error (E_{OS}), and so forth. As a result, SINAD is degraded. See Table 33.7 Input voltage for the SDADC24 and results of A/D conversion in User's Manual for the relation between analog input and digital output.

Note 3. Not production tested but is guaranteed by the design and characterization.

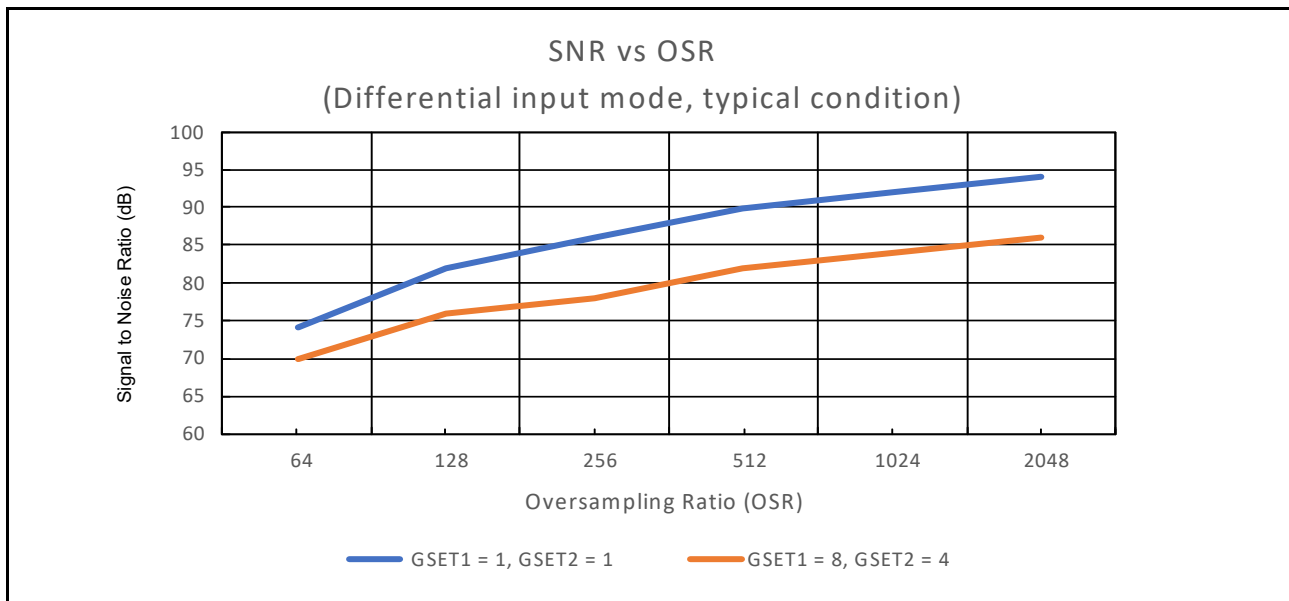

Figure 2.63 SNR vs. OSR (reference data)

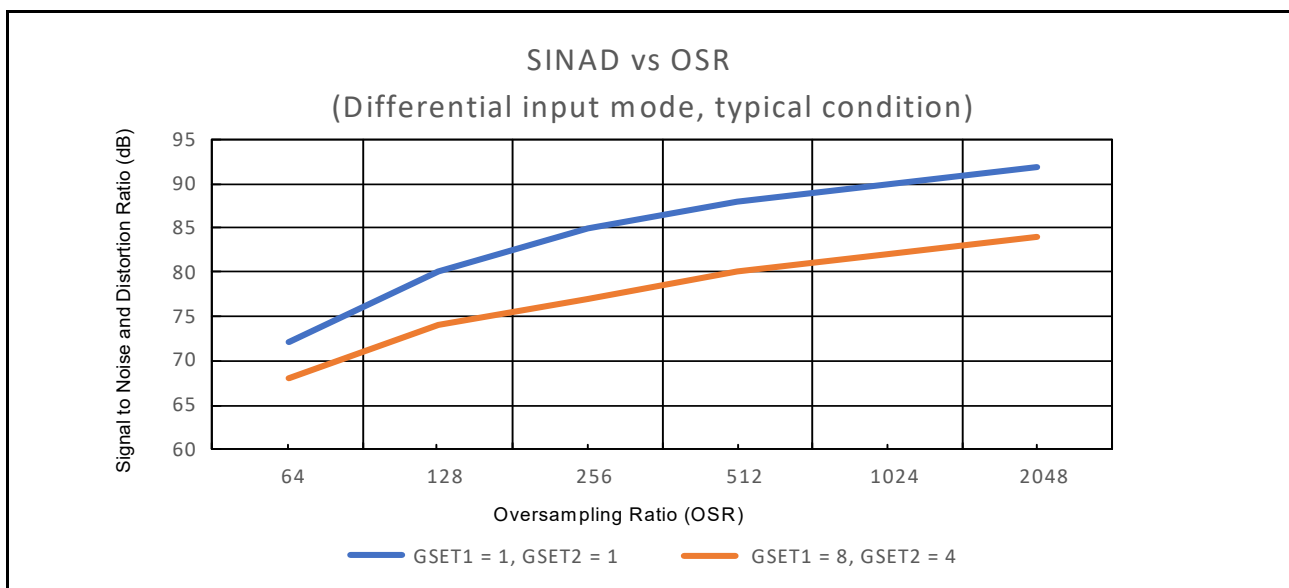

Figure 2.64 SINAD vs. OSR (reference data)

Table 2.50 Programmable gain instrumentation amplifier and sigma-delta A/D converter (3) (1 of 2)

Conditions: VCC = AVCC0 = AVCC1 = 2.7 to 5.5 V, VSS = AVSS0 = AVSS1 = 0 V

The electrical specifications are applied at the differential input mode, with external clock input used, Fos = 1 MHz, OSR = 256, and d_{OFFR} = 0 mV, unless otherwise specified.

| Parameter | Symbol | Min | Typ | Max | Unit | Test conditions |
|---|----------------|------|-----|-----|------|--|
| Gain error*2 (excluding SINC3 frequency response characteristic) | E _G | -0.5 | - | 0.5 | % | After internal calibration, excluding SBIAS error or VREF1 error, G _{SET1} = 1, G _{SET2} = 1 |
| | | -3 | - | 3 | | Single-ended input mode, excluding SBIAS error or VREF1 error, G _{SET1} = 1, G _{SET2} = 1 |

Table 2.50 Programmable gain instrumentation amplifier and sigma-delta A/D converter (3) (2 of 2)

Conditions: VCC = AVCC0 = AVCC1 = 2.7 to 5.5 V, VSS = AVSS0 = AVSS1 = 0 V

The electrical specifications are applied at the differential input mode, with external clock input used, Fos = 1 MHz, OSR = 256, and d_{OFR} = 0 mV, unless otherwise specified.

| Parameter | Symbol | Min | Typ | Max | Unit | Test conditions |
|--|---------------------|------|-----|-----|------------|--|
| Gain drift*1, *2 | dE _G | - | 6 | 22 | ppm/°C | Excluding SBIAS error or VREFI error, G _{SET1} = 1, G _{SET2} = 1 |
| Offset error*2 | E _{OS} | -1 | - | 1 | mV | After internal calibration, G _{SET1} = 1, G _{SET2} = 1, referred to input |
| | | -50 | - | 50 | | Single-ended input mode, including SBIAS error, G _{SET1} = 1, G _{SET2} = 1, referred to input |
| Offset drift*1, *2 | dE _{OS} | - | 2 | 6 | μV/°C | Referred to input |
| | | - | - | 120 | | Single-ended input mode, including SBIAS error, G _{SET1} = 1, G _{SET2} = 1 |
| Integral non-linearity*2 | INL | - | 15 | - | ppm of FSR | Input = DC, OSR = 2048 |
| Common mode Rejection ratio*2 | CMRR | - | 80 | - | dB | V _{COM} = 1.0 ± 0.8 V, f _{in} = 50 Hz, G _{SET1} = 1, G _{SET2} = 1 |
| Power supply Rejection ratio*2 | PSRR | - | 70 | - | dB | AVCC1 = 5.0 V + 0.1 V _{pp_ripple} , f _{in} = 50 Hz, G _{SET1} = 1, G _{SET2} = 1, excluding SBIAS error or VREFI error |
| Input absolute current*2 | I _{IN} | - | 2 | - | nA | V _I = 1 V |
| Input offset current*2 | I _{INOFFR} | - | 1 | - | nA | V _{ID} = 0 V, V _{COM} = 1 V |
| Input impedance*2 | Z _{IN} | - | 500 | - | Mohm | V _{ID} = 1 V, V _{COM} = 1 V |
| Offset adjust gain error*2 | d _{OFGE} | -5 | - | 5 | % | Including SBIAS error, d _{OFR} ≠ 0 mV |
| Offset adjust integral non-linearity*2 | d _{OFINL} | -0.5 | - | 0.5 | LSB | d _{OFR} ≠ 0 mV |

Note: The characteristics apply when no pin functions other than 24-bit sigma-delta A/D converter input are used.

Note 1. Gain drift is calculated by (Max (EG (T (-40°C) to T (125°C))) - Min (EG (T (-40°C) to T (125°C)))) / (125°C - (-40°C))

Offset drift is calculated by (Max (EOS (T (-40°C) to T (125°C))) - Min (EOS (T (-40°C) to T (125°C)))) / (125°C - (-40°C)).

Note 2. Not production tested but is guaranteed by the design and characterization.

Table 2.51 2.1 V LDO linear regulator for ADC (ADREG) characteristics

Conditions: VCC = AVCC0 = AVCC1 = 2.7 to 5.5 V, VSS = AVSS0 = AVSS1 = 0 V

Connect the ADREG pin to a AVSS1 pin by a 0.47 μF (-50% to +20%) capacitor.

| Parameter | Symbol | Min | Typ | Max | Unit | Test conditions |
|----------------------|--------------------|-----|-----|-----|------|-----------------|
| ADREG output voltage | V _{ADREG} | - | 2.1 | - | V | - |

Table 2.52 ADC external reference voltage (VREFI) characteristics

Conditions: VCC = AVCC0 = AVCC1 = 2.7 to 5.5 V, VSS = AVSS0 = AVSS1 = 0 V

| Parameter | Symbol | Min | Typ | Max | Unit | Test conditions |
|-------------------------------------|--------------------|-----|-----|-----|------|-----------------------|
| External reference voltage range*1 | VREFI | 0.8 | - | 2.4 | V | SDADCSTC1.VREFSEL = 1 |
| External reference voltage step | VR _{STEP} | - | 0.2 | - | V | SDADCSTC1.VREFSEL = 1 |
| External reference voltage accuracy | VR _A | -3 | - | 3 | % | SDADCSTC1.VREFSEL = 1 |

Note 1. Select the reference voltage input value with STC1.VSBIAS[3:0].

Table 2.53 Sensor bias (SBIAS) characteristics

Conditions: VCC = AVCC0 = AVCC1 = 2.7 to 5.5 V, VSS = AVSS0 = AVSS1 = 0 V

Connect the SBIAS/VREF1 pin to a AVSS1 pin by a 0.22 μ F (-20% to +20%)

| Parameter | Symbol | Min | Typ | Max | Unit | Test conditions |
|----------------------------------|---------------------|-----|-----|-----|---------|--|
| Output voltage range*2 | SBIAS | 0.8 | - | 2.2 | V | - |
| Output voltage step | SV _{STEP} | - | 0.2 | - | V | - |
| Output voltage accuracy*1 | SV _A | -3 | - | 3 | % | SI _{OUT} = 1 mA |
| Output current*1 | SI _{OUT} | - | - | 10 | mA | - |
| Short current*1 | SI _{SHORT} | - | 35 | 65 | mA | SBIAS = 0 V |
| Load regulation*1 | SL _R | - | - | 15 | mV | 1 mA \leq SI _{OUT} \leq 5 mA |
| | | - | - | 20 | mV | 1 mA \leq SI _{OUT} \leq 10 mA |
| Power supply rejection ratio*1 | SPSRR | - | 50 | - | dB | AVCC1 = 5.0 V + 0.1 V _{pp_ripple} , f = 100 Hz, SI _{OUT} = 2.5 mA |
| Transition time of one step*1,*3 | ST _{TS} | - | - | 80 | μ s | SBIAS < SV _A \pm 3% |
| | | - | - | - | - | 1 mA \leq SI _{OUT} \leq SI _{OUT_MAX} |

Note 1. Not production tested but is guaranteed by the design and characterization.

Note 2. Select the reference voltage output value for the sensor with STC1.VSBIAS[3:0].

Note 3. The load current of more than 1 mA is required because the output stage of SBIAS is Pch open drain. When the original load current is small, additional external load resistance is required.

2.7 DAC12 Characteristics

Table 2.54 12-bit D/A conversion characteristics

Conditions: VCC = AVCC0 = AVCC1 = 1.7 V to 5.5 V, VREFH = 1.7 V to 5.5 V, VSS = AVSS0 = AVSS1 = VREFL = 0 V

| Parameter | | Min | Typ | Max | Unit | Test conditions |
|--------------------------------------|---------------------------------------|-----|-----|-----------|------------|---|
| Resolution | | - | - | 12 | bit | - |
| Charge pump stabilization time*1 | | - | - | 100 | μ s | - |
| SW stabilization time*1 | | - | - | 50 | μ s | - |
| Conversion time*1 | DAC Ref. = AVCC or VREFH \geq 2.7 V | - | - | 1.0 | μ s | Cl _{oad} = 38 pF, @ 1 LSB step Cl _{oad} = 8 pF, @ full range |
| | DAC Ref. = AVCC or VREFH < 2.7 V | - | - | 1.2 | μ s | - |
| Wake-up time*1 | | - | - | 1.0 | μ s | - |
| Absolute accuracy | | - | - | \pm 12 | LSB | 2-M Ω resistive load |
| DNL differential non-linearity error | DAC Ref. = AVCC or VREFH \geq 2.7 V | - | - | \pm 1.0 | LSB | - |
| | DAC Ref. = AVCC or VREFH < 2.7 V | - | - | \pm 2.0 | LSB | - |
| INL integral non-linearity error | | - | - | \pm 7.0 | LSB | - |
| RO output resistance | | - | 3.5 | - | k Ω | - |
| Load resistance | | 2 | 2 | - | M Ω | - |
| Load capacitance | 1 LSB step | - | 38 | - | pF | - |
| | Full range | - | 8 | - | pF | - |

Note 1. These values are based on simulation. They are not production tested.

2.8 DAC8 Characteristics

Table 2.55 8-bit D/A conversion characteristics

Conditions: VCC = AVCC0 = AVCC1 = 1.7 V to 5.5 V, VSS = AVSS0 = AVSS1 = 0 V

| Parameter | | Min | Typ | Max | Unit | Test conditions |
|----------------------------------|----------------------|-----|-----|-------|------|-----------------------|
| Resolution | | - | - | 8 | bit | - |
| Charge pump stabilization time*1 | | - | - | 100 | μs | - |
| Switch stabilization time*1 | | - | - | 50 | μs | - |
| Conversion time*1 | AVCC0 = 2.7 to 5.5 V | - | - | 3.0 | μs | 35-pF capacitive load |
| | AVCC0 = 1.7 to 2.7 V | - | - | 6.0 | μs | |
| Absolute accuracy | AVCC0 = 2.7 to 5.5 V | - | - | ± 3.0 | LSB | 2-MΩ resistive load |
| | AVCC0 = 1.7 to 2.7 V | - | - | ± 3.5 | | |
| | AVCC0 = 2.7 to 5.5 V | - | - | ± 2.0 | LSB | 4-MΩ resistive load |
| | AVCC0 = 1.7 to 2.7 V | - | - | ± 2.5 | | |
| RO output resistance | | - | 7.4 | - | kΩ | - |

Note 1. These values are based on simulation. They are not production tested.

2.9 TSN Characteristics

Table 2.56 TSN characteristics

Conditions: VCC = AVCC0 = AVCC1 = 2.0 to 5.5 V

| Parameter | Symbol | Min | Typ | Max | Unit | Test conditions |
|-------------------------------|--------------------|-----|-------|-----|-------|-----------------|
| Relative accuracy | - | - | ± 1.5 | - | °C | 2.4 V or above |
| | | - | ± 2.0 | - | °C | Below 2.4 V |
| Temperature slope | - | - | -3.65 | - | mV/°C | - |
| Output voltage (at 25°C) | - | - | 1.05 | - | V | VCC = 3.3 V |
| Temperature sensor start time | t _{START} | - | - | 5 | μs | - |
| Sampling time | - | 5 | - | - | μs | - |

2.10 OSC Stop Detect Characteristics

Table 2.57 Oscillation stop detection circuit characteristics

| Parameter | Symbol | Min | Typ | Max | Unit | Test conditions |
|----------------|-----------------|-----|-----|-----|------|-----------------|
| Detection time | t _{dr} | - | - | 1 | ms | Figure 2.65 |

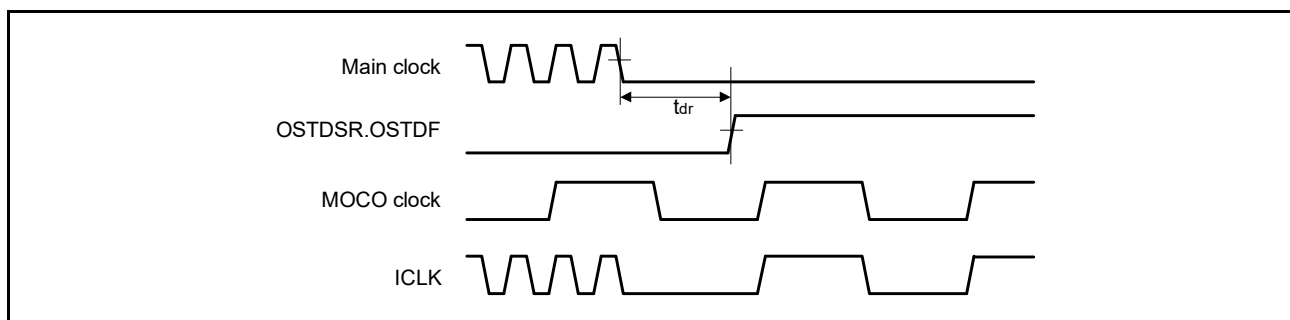
Figure 2.65 Oscillation stop detection timing

2.11 POR and LVD Characteristics

Table 2.58 Power-on reset circuit and voltage detection circuit characteristics (1)

| Parameter | | Symbol | Min | Typ | Max | Unit | Test Conditions |
|------------------------------------|------------------------------------|---------------|------|------|------|---|--|
| Voltage detection level*1 | Power-on reset (POR) | V_{POR} | 1.27 | 1.42 | 1.57 | V | Figure 2.66 , Figure 2.67 |
| | Voltage detection circuit (LVD0)*2 | V_{det0_0} | 3.68 | 3.85 | 4.00 | V | Figure 2.68 At falling edge VCC |
| | | V_{det0_1} | 2.68 | 2.85 | 2.96 | | |
| | | V_{det0_2} | 2.38 | 2.53 | 2.64 | | |
| | | V_{det0_3} | 1.78 | 1.90 | 2.02 | | |
| | | V_{det0_4} | 1.60 | 1.69 | 1.82 | | |
| | Voltage detection circuit (LVD1)*3 | V_{det1_0} | 4.13 | 4.29 | 4.45 | V | Figure 2.69 At falling edge VCC |
| | | V_{det1_1} | 3.98 | 4.16 | 4.30 | | |
| | | V_{det1_2} | 3.86 | 4.03 | 4.18 | | |
| | | V_{det1_3} | 3.68 | 3.86 | 4.00 | | |
| | | V_{det1_4} | 2.98 | 3.10 | 3.22 | | |
| | | V_{det1_5} | 2.89 | 3.00 | 3.11 | | |
| | | V_{det1_6} | 2.79 | 2.90 | 3.01 | | |
| | | V_{det1_7} | 2.68 | 2.79 | 2.90 | | |
| | | V_{det1_8} | 2.58 | 2.68 | 2.78 | | |
| | | V_{det1_9} | 2.48 | 2.58 | 2.68 | | |
| | | V_{det1_A} | 2.38 | 2.48 | 2.58 | | |
| | | V_{det1_B} | 2.10 | 2.20 | 2.30 | | |
| | | V_{det1_C} | 1.84 | 1.96 | 2.05 | | |
| | | V_{det1_D} | 1.74 | 1.86 | 1.95 | | |
| V_{det1_E} | | 1.63 | 1.75 | 1.84 | | | |
| V_{det1_F} | 1.60 | 1.65 | 1.73 | | | | |
| Voltage detection circuit (LVD2)*4 | V_{det2_0} | 4.11 | 4.31 | 4.48 | V | Figure 2.70 At falling edge VCC | |
| | V_{det2_1} | 3.97 | 4.17 | 4.34 | | | |
| | V_{det2_2} | 3.83 | 4.03 | 4.20 | | | |
| | V_{det2_3} | 3.64 | 3.84 | 4.01 | | | |

Note 1. These characteristics apply when noise is not superimposed on the power supply. When a setting causes this voltage detection level to overlap with that of the voltage detection circuit, it cannot be specified whether LVD1 or LVD2 is used for voltage detection.

Note 2. # in the symbol $V_{det0_#}$ denotes the value of the OFS1.VDSEL1[2:0] bits.

Note 3. # in the symbol $V_{det1_#}$ denotes the value of the LVDLVLR.LVD1LVL[4:0] bits.

Note 4. # in the symbol $V_{det2_#}$ denotes the value of the LVDLVLR.LVD2LVL[2:0] bits.

Table 2.59 Power-on reset circuit and voltage detection circuit characteristics (2)

| Parameter | Symbol | Min | Typ | Max | Unit | Test Conditions | |
|--|-----------------|----------------|-----|-----|---------|---|---|
| Wait time after power-on reset cancellation | LVD0: enable | t_{POR} | - | 1.7 | - | ms | - |
| | LVD0: disable | t_{POR} | - | 1.3 | - | ms | - |
| Wait time after voltage monitor 0, 1, 2 reset cancellation | LVD0: enable*1 | $t_{LVD0,1,2}$ | - | 0.6 | - | ms | - |
| | LVD0: disable*2 | $t_{LVD1,2}$ | - | 0.2 | - | ms | - |
| Response delay*3 | t_{det} | - | - | 350 | μ s | Figure 2.66, Figure 2.67 | |
| Minimum VCC down time | t_{VOFF} | 450 | - | - | μ s | Figure 2.66, VCC = 1.0 V or above | |
| Power-on reset enable time | t_W (POR) | 1 | - | - | ms | Figure 2.67, VCC = below 1.0 V | |
| LVD operation stabilization time (after LVD is enabled) | T_d (E-A) | - | - | 300 | μ s | Figure 2.69, Figure 2.70 | |
| Hysteresis width (POR) | V_{PORH} | - | 110 | - | mV | - | |
| Hysteresis width (LVD0, LVD1 and LVD2) | V_{LVH} | - | 60 | - | mV | LVD0 selected | |
| | | - | 100 | - | | V_{det1_0} to V_{det1_2} selected | |
| | | - | 60 | - | | V_{det1_3} to V_{det1_9} selected | |
| | | - | 50 | - | | V_{det1_A} to V_{det1_B} selected | |
| | | - | 40 | - | | V_{det1_C} to V_{det1_F} selected | |
| | | - | 60 | - | | LVD2 selected | |

Note 1. When OFS1.LVDAS = 0.

Note 2. When OFS1.LVDAS = 1.

Note 3. The minimum VCC down time indicates the time when VCC is below the minimum value of voltage detection levels V_{POR} , V_{det0} , V_{det1} , and V_{det2} for the POR/LVD.

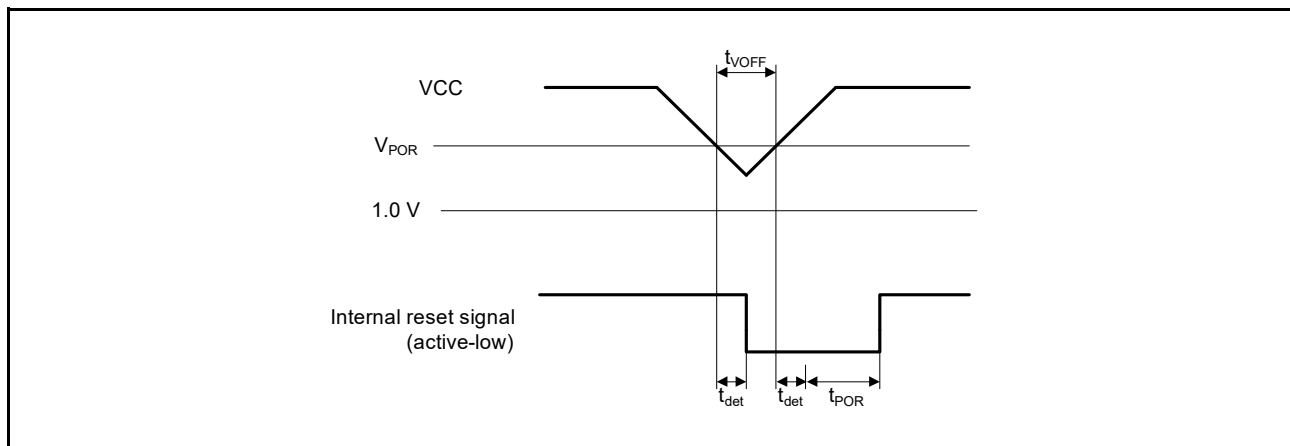
**Figure 2.66 Voltage detection reset timing**

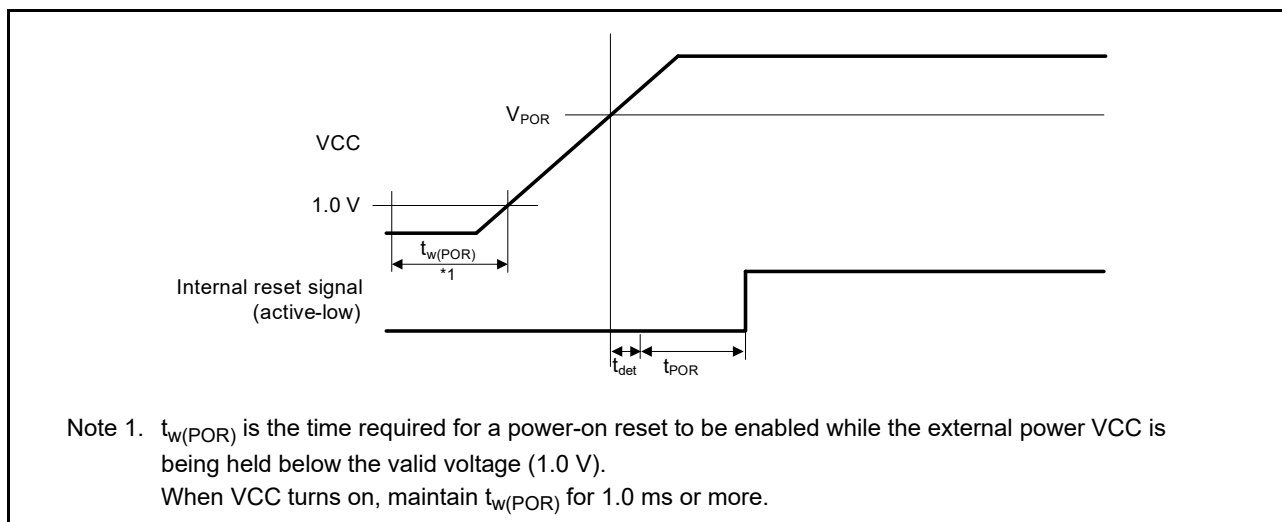

Figure 2.67 Power-on reset timing

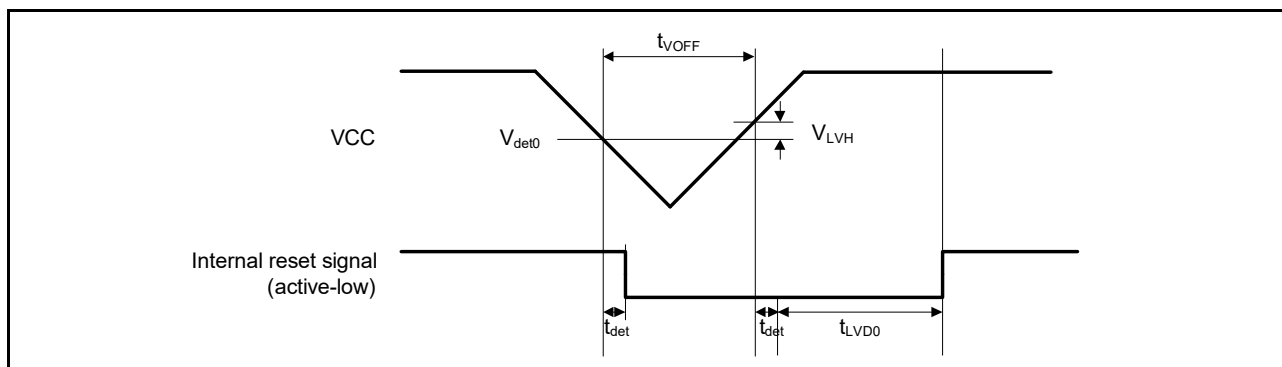

Figure 2.68 Voltage detection circuit timing (V_{det0})

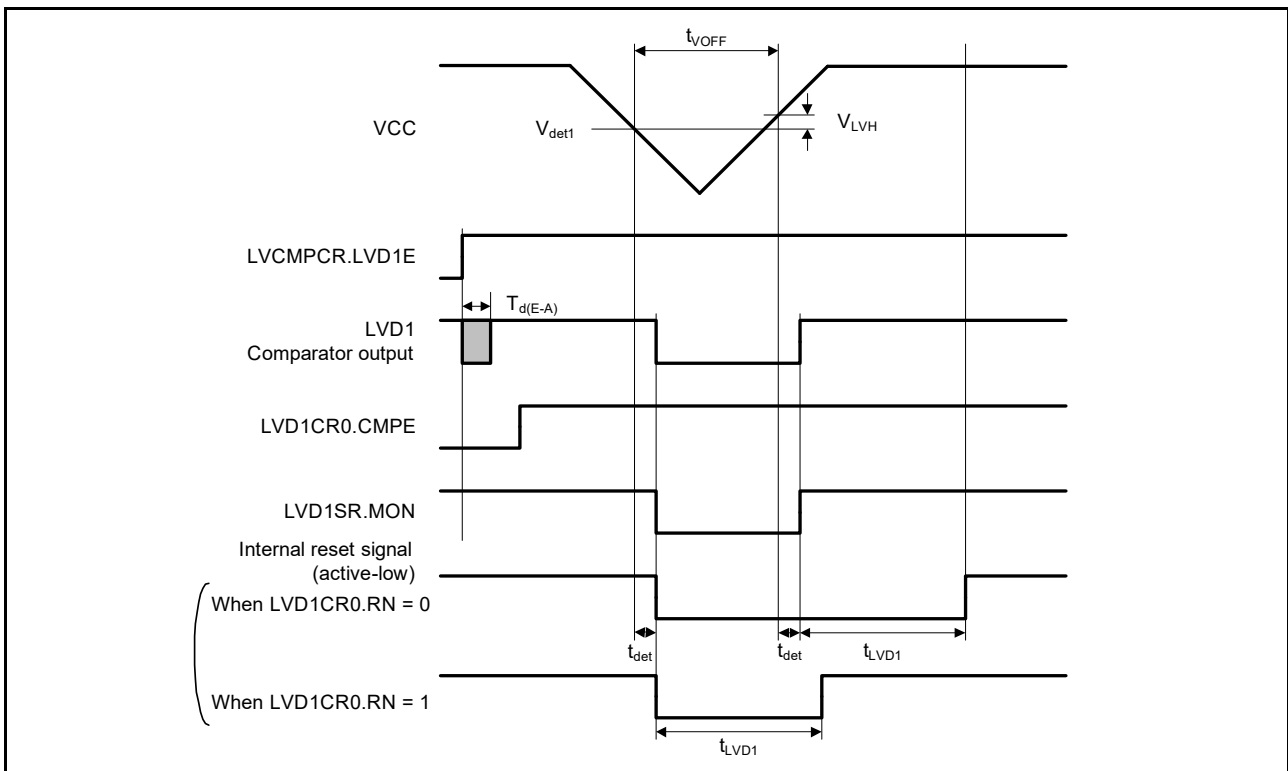

Figure 2.69 Voltage detection circuit timing (V_{det1})

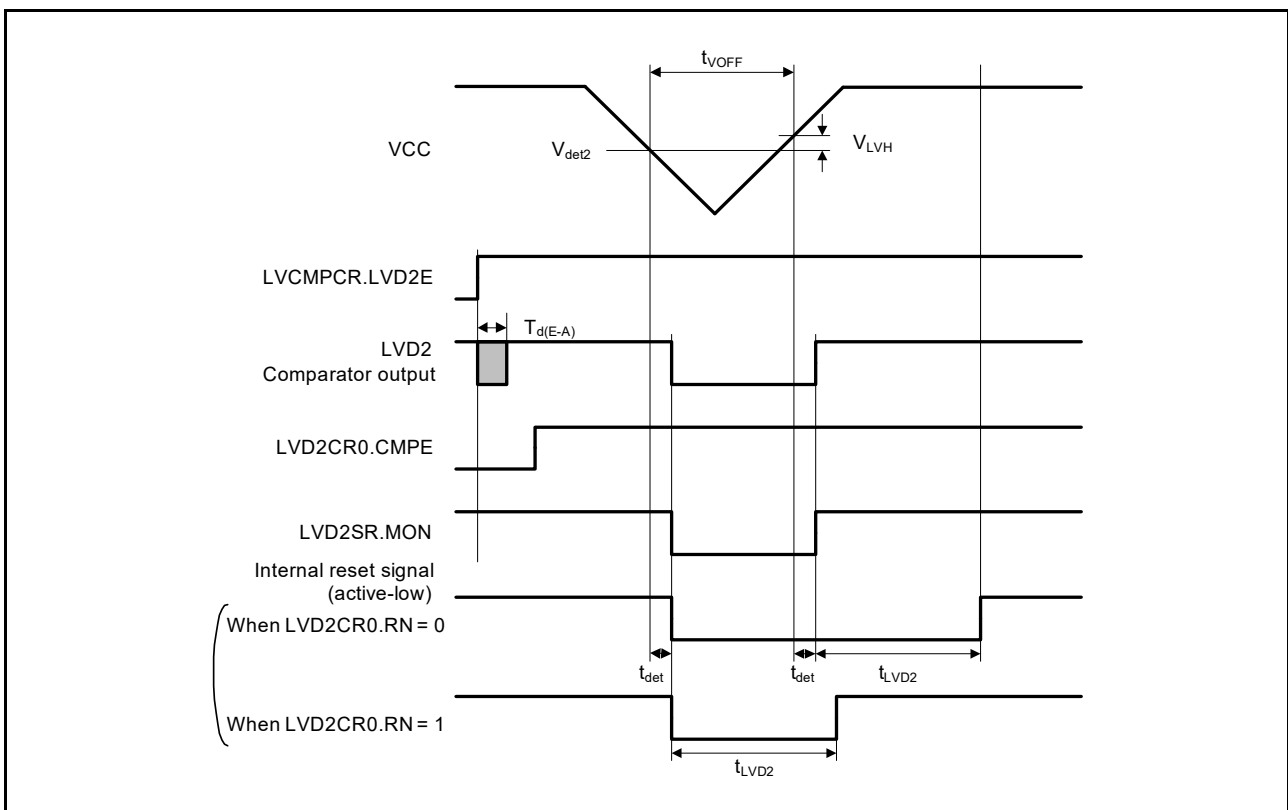

Figure 2.70 Voltage detection circuit timing (V_{det2})

2.12 CTSU Characteristics

Table 2.60 CTSU characteristics

Conditions: VCC = AVCC0 = AVCC1 = 1.8 to 5.5 V

| Parameter | Symbol | Min | Typ | Max | Unit | Test conditions |
|---|--------------------|-----|-----|-----|------|--|
| External capacitance connected to TSCAP pin | C _{tscap} | 9 | 10 | 11 | nF | - |
| TS pin capacitive load | C _{base} | - | - | 50 | pF | - |
| Permissible output high current | ΣI_{OH} | - | - | -24 | mA | When the mutual capacitance method is applied and TS07 to TS14 are not used for transmit channel |
| | | - | - | -14 | | When the mutual capacitance method is applied and TS07 to TS14 are used for transmit channel |

2.13 Comparator Characteristics

Table 2.61 ACMPHS characteristics

Conditions: VCC = AVCC0 = AVCC1 = 2.7 to 5.5 V, VSS = AVSS0 = AVSS1 = 0 V

| Parameter | Symbol | Min | Typ | Max | Unit | Test conditions |
|--|---------------------|------|------|-------|------|--------------------------|
| Input offset voltage | V _{IOCOMP} | - | ± 5 | ± 40 | mV | - |
| Input voltage range | V _{ICPM} | 0 | - | AVCC0 | V | - |
| Internal reference voltage input*3 | V _{ref} | 1.36 | 1.43 | 1.50 | V | AVCC0 ≥ 2.0 V |
| Input signal cycle | t _{PCMP} | 10 | - | - | μs | - |
| Output delay time | T _d | - | 50 | 100 | ns | Input amplitude ± 100 mV |
| Stabilization wait time during input channel switching*1 | T _{WAIT} | 300 | - | - | ns | Input amplitude ± 100 mV |
| Operation stabilization wait time*2 | T _{cmp} | 1 | - | - | μs | 3.3 V ≤ AVCC0 ≤ 5.5 V |
| | | 3 | - | - | μs | 2.7 V ≤ AVCC0 < 3.3 V |

Note 1. Period from when the comparator input channel is switched until the switched result reflects in its output.

Note 2. Period from when comparator operation is enabled (CPMCTL.HCMPON = 1) until the comparator satisfies the DC/AC characteristics.

Note 3. The internal reference voltage cannot be selected for input channels when AVCC0 < 2.0 V.

Table 2.62 ACMPLP characteristics

Conditions: VCC = AVCC0 = AVCC1 = 1.8 to 5.5 V, VSS = AVSS0 = AVSS1 = 0 V

| Parameter | Symbol | Min | Typ | Max | Unit | Test conditions | |
|------------------------------|--|------------------|-------|------|-------------|-----------------|---|
| Input voltage range | IVREF0 | V _{REF} | 0 | - | VCC - 1.4*1 | V | - |
| | IVREF1 (Standard mode) | | 0 | - | VCC - 1.4 | V | |
| | IVREF1 (Window mode) | | 1.4*1 | - | VCC | V | |
| | IVCMP0, IVCMP1 | V _I | 0 | - | VCC | V | |
| Internal reference voltage*2 | - | 1.36 | 1.43 | 1.50 | V | VCC ≥ 2.0 V | |
| Output delay | Comparator high-speed mode (Standard mode) | T _d | - | - | 1.2 | μs | VCC = 3.0 V Slew rate of input signal > 50 mV/μs |
| | Comparator high-speed mode (Window mode) | | - | - | 2.0 | μs | |
| | Comparator low-speed mode (Standard mode) | | - | - | 5.0 | μs | |

Table 2.62 ACMPLP characteristicsConditions: $V_{CC} = AV_{CC0} = AV_{CC1} = 1.8$ to 5.5 V, $V_{SS} = AV_{SS0} = AV_{SS1} = 0$ V

| Parameter | | Symbol | Min | Typ | Max | Unit | Test conditions |
|-----------------------------------|--|-----------|-----|-----|-----|---------|-----------------|
| Offset voltage | Comparator high-speed mode (Standard mode) | - | - | - | 50 | mV | - |
| | Comparator high-speed mode (Window mode) | - | - | - | 60 | mV | |
| | Comparator low-speed mode (Standard mode) | - | - | - | 40 | mV | |
| Operation stabilization wait time | | T_{cmp} | 100 | - | - | μ s | - |

Note 1. In window mode, be sure to satisfy the following condition: $V_{IVREF1} - V_{IVREF0} \geq 0.2$ V.Note 2. The internal reference voltage cannot be selected for input channels when $V_{CC} < 2.0$ V.

2.14 OPAMP Characteristics

Table 2.63 OPAMP characteristics (1 of 3)Conditions: $V_{CC} = AV_{CC0} = AV_{CC1} = 1.7$ V to 5.5 V, $V_{SS} = AV_{SS0} = AV_{SS1} = 0$ V

| Parameter | Symbol | Conditions | Min | Typ | Max | Unit |
|----------------------------------|----------------|---|-------|-----|-------|---------|
| Supply voltage range | AVCC0 | Low power mode | 1.7 | - | 5.5 | V |
| | | Middle-speed mode | 2.1 | - | 5.5 | V |
| | | High-speed mode | 2.4 | - | 5.5 | V |
| Charge pump stabilization time*1 | - | - | - | - | 100 | μ s |
| SW stabilization time*1 | - | - | - | - | 50 | μ s |
| Input voltage range | V_{icm1} | Low power mode | AVSS0 | - | AVCC0 | V |
| | V_{icm2} | Middle-speed mode | | | | |
| | V_{icm3} | High-speed mode | | | | |
| Output voltage range | V_{olh1} | Low power mode, I _{load} = 100 μ A | AVSS0 | - | AVCC0 | V |
| | V_{olh2} | Middle-speed mode, I _{load} = 100 μ A | | | | |
| | V_{olh3} | High-speed mode, I _{load} = 100 μ A | | | | |
| Input offset trimming range*1 | $V_{offadj2l}$ | Middle-speed mode, V _{in} = 0.1 V, T _j = 25°C | -3 | - | 3 | mV |
| | $V_{offadj2h}$ | Middle-speed mode, V _{in} = AVCC0 - 0.1 V, T _j = 25°C | | | | |
| | $V_{offadj3l}$ | High-speed mode, V _{in} = 0.1 V, T _j = 25°C | | | | |
| | $V_{offadj3h}$ | High-speed mode, V _{in} = AVCC0 - 0.1 V, T _j = 25°C | | | | |

Table 2.63 OPAMP characteristics (2 of 3)

Conditions: VCC = AVCC0 = AVCC1 = 1.7 V to 5.5 V, VSS = AVSS0 = AVSS1 = 0 V

| Parameter | Symbol | Conditions | Min | Typ | Max | Unit |
|--------------------------|---------------------|---|------|-----|-----|--------|
| Input offset*1 | V _{ioff1a} | Low power mode, V _{in} < AVCC0 - 1.0 V | -5.0 | - | 5.0 | mV |
| | V _{ioff1b} | Low power mode, V _{in} ≥ AVCC0 - 1.0 V | -8.0 | - | 8.0 | |
| | V _{ioff2a} | Middle-speed mode, V _{in} < AVCC0 - 1.2 V | -3.0 | - | 3.0 | |
| | V _{ioff2b} | Middle-speed mode, V _{in} ≥ AVCC0 - 1.2 V | -3.0 | - | 3.0 | |
| | V _{ioff3a} | High-speed mode, V _{in} < AVCC0 - 1.2 V | -2.5 | - | 2.5 | |
| | V _{ioff3b} | High-speed mode, V _{in} ≥ AVCC0 - 1.2 V | -2.5 | - | 2.5 | |
| Offset drift*1 | Drift1a | Low power mode, V _{in} < AVCC0 - 1.0 V | -70 | - | 70 | μV/°C |
| | Drift1b | Low power mode, V _{in} ≥ AVCC0 - 1.0 V | -70 | - | 70 | |
| | Drift2a | Middle-speed mode, V _{in} < AVCC0 - 1.2 V | -30 | - | 30 | |
| | Drift2b | Middle-speed mode, V _{in} ≥ AVCC0 - 1.2 V | -30 | - | 30 | |
| | Drift3a | High-speed mode, V _{in} < AVCC0 - 1.2 V | -30 | - | 30 | |
| | Drift3b | High-speed mode, V _{in} ≥ AVCC0 - 1.2 V | -30 | - | 30 | |
| Open gain*1 | Av1 | Low power mode | 70 | 130 | - | dB |
| | Av2 | Middle-speed mode | 70 | 120 | - | |
| | Av3 | High-speed mode | 60 | 130 | - | |
| Gain bandwidth product*1 | GBW1 | Low power mode | - | 90 | - | kHz |
| | GBW2 | Middle-speed mode | - | 2 | - | MHz |
| | GBW3 | High-speed mode | - | 4.8 | - | MHz |
| Phase margin*1 | PM1 | Low power mode | 35 | - | - | deg |
| | PM2 | Middle-speed mode | 35 | - | - | |
| | PM3 | High-speed mode | 35 | - | - | |
| Gain margin*1 | GM1 | Low power mode | 10 | - | - | dB |
| | GM2 | Middle-speed mode | 10 | - | - | |
| | GM3 | High-speed mode | 10 | - | - | |
| Input noise density*1 | V _{ind11} | Low power mode, f = 10 Hz | - | 860 | - | nV/√Hz |
| | V _{ind12} | Low power mode, f = 1 kHz | - | 260 | - | |
| | V _{ind21} | Middle-speed mode, f = 1 kHz | - | 50 | - | |
| | V _{ind22} | Middle-speed mode, f = 100 kHz | - | 30 | - | |
| | V _{ind31} | High-speed mode, f = 1 kHz | - | 40 | - | |
| | V _{ind32} | High-speed mode, f = 100 kHz | - | 20 | - | |

Table 2.63 OPAMP characteristics (3 of 3)

Conditions: VCC = AVCC0 = AVCC1 = 1.7 V to 5.5 V, VSS = AVSS0 = AVSS1 = 0 V

| Parameter | Symbol | Conditions | Min | Typ | Max | Unit |
|--------------------------------|----------------------|---|------|-------|------|---------|
| Power supply rejection ratio*1 | PSRR1 | Low power mode | - | 90 | - | dB |
| | PSRR2 | Middle-speed mode | - | 90 | - | |
| | PSRR3 | High-speed mode | - | 90 | - | |
| Common mode rejection ratio*1 | CMRR1 | Low power mode | - | 90 | - | dB |
| | CMRR2 | Middle-speed mode | - | 90 | - | |
| | CMRR3 | High-speed mode | - | 90 | - | |
| Settling time*1 | T _{set1} | Low power mode | - | 70 | 200 | μs |
| | T _{set2} | Middle-speed mode | - | 2.8 | 8 | |
| | T _{set3} | High-speed mode | - | 1.2 | 3.2 | |
| Slew rate*1 | SR1 | Low power mode | 0.02 | 0.05 | - | V/μs |
| | SR2 | Middle-speed mode | 0.8 | 1.3 | - | |
| | SR3 | High-speed mode | 1.8 | 3.0 | - | |
| Turn on time*1 | T _{tum1} | Low power mode, AMPENx = 0 → 1, IREFEN = 0 → 1 | - | 80 | 220 | μs |
| | T _{tum2} | Middle-speed mode, AMPENx = 0 → 1, IREFEN = 0 → 1 | - | 3 | 10 | |
| | T _{tum3} | High-speed mode, AMPENx = 0 → 1, IREFEN = 0 → 1 | - | 1.3 | 4 | |
| Input offset trimming step*1 | V _{iofst2} | Middle-speed mode, Vin < AVCC0 - 1.2 V | 0.3 | 0.459 | 0.58 | mV/code |
| | | Middle-speed mode, Vin ≥ AVCC0 - 1.2 V | 0.24 | - | 0.56 | |
| | V _{iofst3} | High-speed mode, Vin < AVCC0 - 1.2 V | 0.35 | 0.52 | 0.65 | |
| | | High-speed mode, Vin ≥ AVCC0 - 1.2 V | 0.28 | - | 0.61 | |
| Wait time after trimming*1 | T _{tum_tm2} | Middle-speed mode | - | - | 1.5 | μs |
| | T _{tum_tm3} | High-speed mode | - | - | 1 | |
| Load current | I _{load} | - | - | - | 100 | μA |
| Load capacitance | C _L | - | - | - | 20 | pF |

Note 1. These values are based on simulation. They are not production tested.

2.15 Flash Memory Characteristics

2.15.1 Code Flash Memory Characteristics

Table 2.64 Code flash characteristics (1)

| Parameter | Symbol | Min | Typ | Max | Unit | Conditions |
|-------------------------------|-----------------------------------|------------------|----------|-----|-------|------------------------|
| Reprogramming/erasure cycle*1 | N _{PEC} | 1000 | - | - | Times | - |
| Data hold time | After 1000 times N _{PEC} | t _{DRP} | 20*2, *3 | - | Year | T _a = +85°C |

Note 1. The reprogram/erase cycle is the number of erasures for each block. When the reprogram/erase cycle is n times (n = 1,000), erasing can be performed n times for each block. For instance, when 4-byte programming is performed 256 times for different addresses in 1-KB blocks, and then the entire block is erased, the reprogram/erase cycle is counted as one. However, programming the same address for several times as one erasure is not enabled (overwriting is prohibited).

Note 2. Characteristic when using the flash memory programmer and the self-programming library provided by Renesas Electronics.

Note 3. This result is obtained from reliability testing.

Table 2.65 Code flash characteristics (2)

High-speed operating mode

Conditions: VCC = AVCC0 = AVCC1 = 2.7 to 5.5 V

| Parameter | | Symbol | FCLK = 1 MHz | | | FCLK = 32 MHz | | | Unit |
|--|--------|-------------------|--------------|------|------|---------------|------|------|------|
| | | | Min | Typ | Max | Min | Typ | Max | |
| Programming time | 8-byte | t _{P8} | - | 116 | 998 | - | 54 | 506 | μs |
| Erase time | 2-KB | t _{E2K} | - | 9.03 | 287 | - | 5.67 | 222 | ms |
| Blank check time | 8-byte | t _{BC8} | - | - | 56.8 | - | - | 16.6 | μs |
| | 2-KB | t _{BC2K} | - | - | 1899 | - | - | 140 | μs |
| Erase suspended time | | t _{SED} | - | - | 22.5 | - | - | 10.7 | μs |
| Startup area switching setting time | | t _{SAS} | - | 21.9 | 585 | - | 12.1 | 447 | ms |
| Access window time | | t _{AWS} | - | 21.9 | 585 | - | 12.1 | 447 | ms |
| OCD/serial programmer ID setting time | | t _{OSIS} | - | 21.9 | 585 | - | 12.1 | 447 | ms |
| Flash memory mode transition wait time 1 | | t _{DIS} | 2 | - | - | 2 | - | - | μs |
| Flash memory mode transition wait time 2 | | t _{MS} | 5 | - | - | 5 | - | - | μs |

Note: Does not include the time until each operation of the flash memory is started after instructions are executed by software.

Note: The lower-limit frequency of FCLK is 1 MHz during programming or erasing the flash memory. When using FCLK at below 4 MHz, the frequency can be set to 1 MHz, 2 MHz, or 3 MHz. A non-integer frequency such as 1.5 MHz cannot be set.

Note: The frequency accuracy of FCLK must be ± 3.5% during programming or erasing the flash memory. Confirm the frequency accuracy of the clock source.

Table 2.66 Code flash characteristics (3)

Middle-speed operating mode

Conditions: VCC = AVCC0 = AVCC1 = 1.8 to 5.5 V, Ta = -40 to +85°C

| Parameter | | Symbol | FCLK = 1 MHz | | | FCLK = 8 MHz | | | Unit |
|--|--------|-------------------|--------------|------|------|--------------|------|------|------|
| | | | Min | Typ | Max | Min | Typ | Max | |
| Programming time | 8-byte | t _{P8} | - | 157 | 1411 | - | 101 | 966 | μs |
| Erase time | 2-KB | t _{E2K} | - | 9.10 | 289 | - | 6.10 | 228 | ms |
| Blank check time | 8-byte | t _{BC8} | - | - | 87.7 | - | - | 52.5 | μs |
| | 2-KB | t _{BC2K} | - | - | 1930 | - | - | 414 | μs |
| Erase suspended time | | t _{SED} | - | - | 32.7 | - | - | 21.6 | μs |
| Startup area switching setting time | | t _{SAS} | - | 22.8 | 592 | - | 14.2 | 465 | ms |
| Access window time | | t _{AWS} | - | 22.8 | 592 | - | 14.2 | 465 | ms |
| OCD/serial programmer ID setting time | | t _{OSIS} | - | 22.8 | 592 | - | 14.2 | 465 | ms |
| Flash memory mode transition wait time 1 | | t _{DIS} | 2 | - | - | 2 | - | - | μs |
| Flash memory mode transition wait time 2 | | t _{MS} | 720 | - | - | 720 | - | - | ns |

Note: Does not include the time until each operation of the flash memory is started after instructions are executed by software.

Note: The lower-limit frequency of FCLK is 1 MHz during programming or erasing the flash memory. When using FCLK at below 4 MHz, the frequency can be set to 1 MHz, 2 MHz, or 3 MHz. A non-integer frequency such as 1.5 MHz cannot be set.

Note: The frequency accuracy of FCLK must be ± 3.5% during programming or erasing the flash memory. Confirm the frequency accuracy of the clock source.

2.15.2 Data Flash Memory Characteristics

Table 2.67 Data flash characteristics (1)

| Parameter | | Symbol | Min | Typ | Max | Unit | Conditions |
|-------------------------------|--|-------------------|----------|---------|-----|-------|------------|
| Reprogramming/erasure cycle*1 | | N _{DPEC} | 100000 | 1000000 | - | Times | - |
| Data hold time | After 10000 times of N _{DPEC} | t _{DDRP} | 20*2, *3 | - | - | Year | Ta = +85°C |
| | After 100000 times of N _{DPEC} | | 5*2, *3 | - | - | Year | |
| | After 1000000 times of N _{DPEC} | | - | 1*2, *3 | - | Year | |

Note 1. The reprogram/erase cycle is the number of erasure for each block. When the reprogram/erase cycle is n times ($n = 100,000$), erasing can be performed n times for each block. For instance, when 1-byte programming is performed 1,000 times for different addresses in 1-byte blocks, and then the entire block is erased, the reprogram/erase cycle is counted as one. However, programming the same address for several times as one erasure is not enabled. (overwriting is prohibited.)

Note 2. Characteristics when using the flash memory programmer and the self-programming library provided by Renesas Electronics.

Note 3. These results are obtained from reliability testing.

Table 2.68 Data flash characteristics (2)

High-speed operating mode

Conditions: VCC = AVCC0 = AVCC1 = 2.7 to 5.5 V

| Parameter | | Symbol | FCLK = 4 MHz | | | FCLK = 32 MHz | | | Unit |
|-------------------------------|--------|-------------|--------------|------|------|---------------|------|------|---------|
| | | | Min | Typ | Max | Min | Typ | Max | |
| Programming time | 1-byte | t_{DP1} | - | 52.4 | 463 | - | 42.1 | 387 | μ s |
| Erase time | 1-KB | t_{DE1K} | - | 8.98 | 286 | - | 6.42 | 237 | ms |
| Blank check time | 1-byte | t_{DBC1} | - | - | 24.3 | - | - | 16.6 | μ s |
| | 1-KB | t_{DBC1K} | - | - | 1872 | - | - | 512 | μ s |
| Suspended time during erasing | | t_{DSED} | - | - | 13.0 | - | - | 10.7 | μ s |
| Data flash STOP recovery time | | t_{DSTOP} | 5 | - | - | 5 | - | - | μ s |

Note: Does not include the time until each operation of the flash memory is started after instructions are executed by software.

Note: The lower-limit frequency of FCLK is 1 MHz during programming or erasing the flash memory. When using FCLK at below 4 MHz, the frequency can be set to 1 MHz, 2 MHz, or 3 MHz. A non-integer frequency such as 1.5 MHz cannot be set.

Note: The frequency accuracy of FCLK must be $\pm 3.5\%$ during programming or erasing the flash memory. Confirm the frequency accuracy of the clock source.

Table 2.69 Data flash characteristics (3)

Middle-speed operating mode

Conditions: VCC = AVCC0 = AVCC1 = 1.8 to 5.5 V, Ta = -40 to +85°C

| Parameter | | Symbol | FCLK = 4 MHz | | | FCLK = 8 MHz | | | Unit |
|-------------------------------|--------|-------------|--------------|------|------|--------------|------|------|---------|
| | | | Min | Typ | Max | Min | Typ | Max | |
| Programming time | 1-byte | t_{DP1} | - | 94.7 | 886 | - | 89.3 | 849 | μ s |
| Erase time | 1-KB | t_{DE1K} | - | 9.59 | 299 | - | 8.29 | 273 | ms |
| Blank check time | 1-byte | t_{DBC1} | - | - | 56.2 | - | - | 52.5 | μ s |
| | 1-KB | t_{DBC1K} | - | - | 2.17 | - | - | 1.51 | ms |
| Suspended time during erasing | | t_{DSED} | - | - | 23.0 | - | - | 21.7 | μ s |
| Data flash STOP recovery time | | t_{DSTOP} | 720 | - | - | 720 | - | - | ns |

Note: Does not include the time until each operation of the flash memory is started after instructions are executed by software.

Note: The lower-limit frequency of FCLK is 1 MHz during programming or erasing the flash memory. When using FCLK at below 4 MHz, the frequency can be set to 1 MHz, 2 MHz, or 3 MHz. A non-integer frequency such as 1.5 MHz cannot be set.

Note: The frequency accuracy of FCLK must be $\pm 3.5\%$ during programming or erasing the flash memory. Confirm the frequency accuracy of the clock source.

2.15.3 Serial Wire Debug (SWD)

Table 2.70 SWD characteristics (1) (1 of 2)

Conditions: VCC = AVCC0 = AVCC1 = 2.4 to 5.5 V

| Parameter | Symbol | Min | Typ | Max | Unit | Test conditions |
|------------------------------|---------------|-----|-----|-----|------|-----------------|
| SWCLK clock cycle time | $t_{SWCKcyc}$ | 80 | - | - | ns | Figure 2.71 |
| SWCLK clock high pulse width | t_{SWCKH} | 35 | - | - | ns | |
| SWCLK clock low pulse width | t_{SWCKL} | 35 | - | - | ns | |
| SWCLK clock rise time | t_{SWCKr} | - | - | 5 | ns | |
| SWCLK clock fall time | t_{SWCKf} | - | - | 5 | ns | |

Table 2.70 SWD characteristics (1) (2 of 2)

Conditions: VCC = AVCC0 = AVCC1 = 2.4 to 5.5 V

| Parameter | Symbol | Min | Typ | Max | Unit | Test conditions |
|-----------------------|------------|-----|-----|-----|------|-----------------|
| SWDIO setup time | t_{SWDS} | 16 | - | - | ns | Figure 2.72 |
| SWDIO hold time | t_{SWDH} | 16 | - | - | ns | |
| SWDIO data delay time | t_{SWDD} | 2 | - | 70 | ns | |

Table 2.71 SWD characteristics (2)

Conditions: VCC = AVCC0 = AVCC1 = 1.6 to 2.4 V

| Parameter | Symbol | Min | Typ | Max | Unit | Test conditions |
|------------------------------|---------------|-----|-----|-----|------|-----------------|
| SWCLK clock cycle time | $t_{SWCKcyc}$ | 250 | - | - | ns | Figure 2.71 |
| SWCLK clock high pulse width | t_{SWCKH} | 120 | - | - | ns | |
| SWCLK clock low pulse width | t_{SWCKL} | 120 | - | - | ns | |
| SWCLK clock rise time | t_{SWCKr} | - | - | 5 | ns | |
| SWCLK clock fall time | t_{SWCKf} | - | - | 5 | ns | |
| SWDIO setup time | t_{SWDS} | 50 | - | - | ns | Figure 2.72 |
| SWDIO hold time | t_{SWDH} | 50 | - | - | ns | |
| SWDIO data delay time | t_{SWDD} | 2 | - | 150 | ns | |

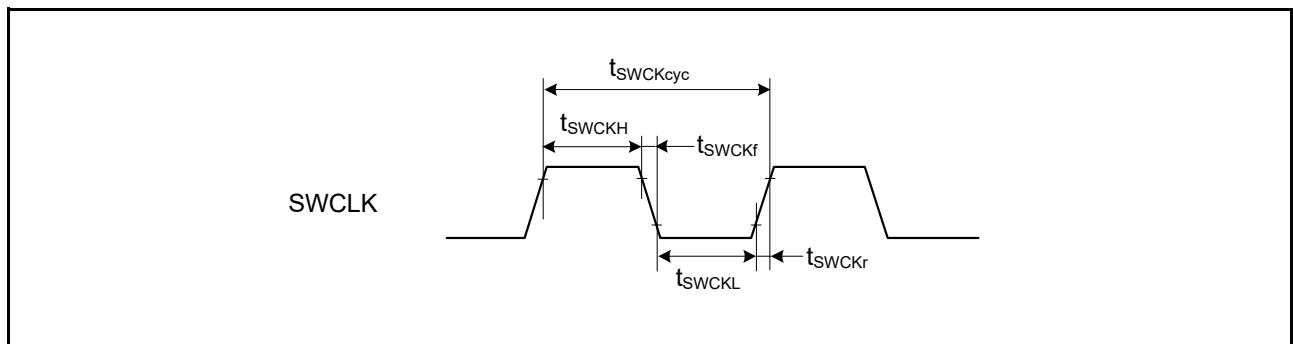

Figure 2.71 SWD SWCLK timing

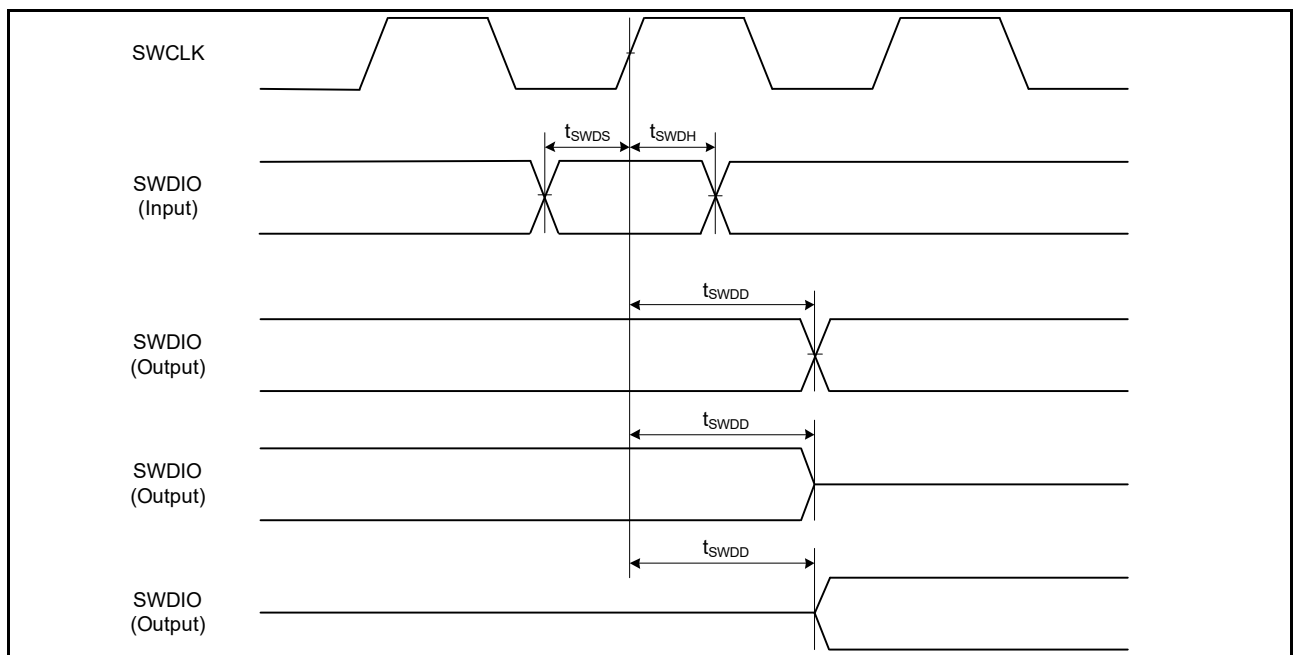

Figure 2.72 SWD input/output timing

Appendix 1. Package Dimensions

Information on the latest version of the package dimensions or mountings is displayed in “Packages” on the Renesas Electronics Corporation website.

| JEITA Package Code | RENESAS Code | Previous Code | MASS (Typ) [g] |
|----------------------|--------------|---------------|----------------|
| P-LFQFP64-10x10-0.50 | PLQP0064KB-C | — | 0.3 |

Unit: mm

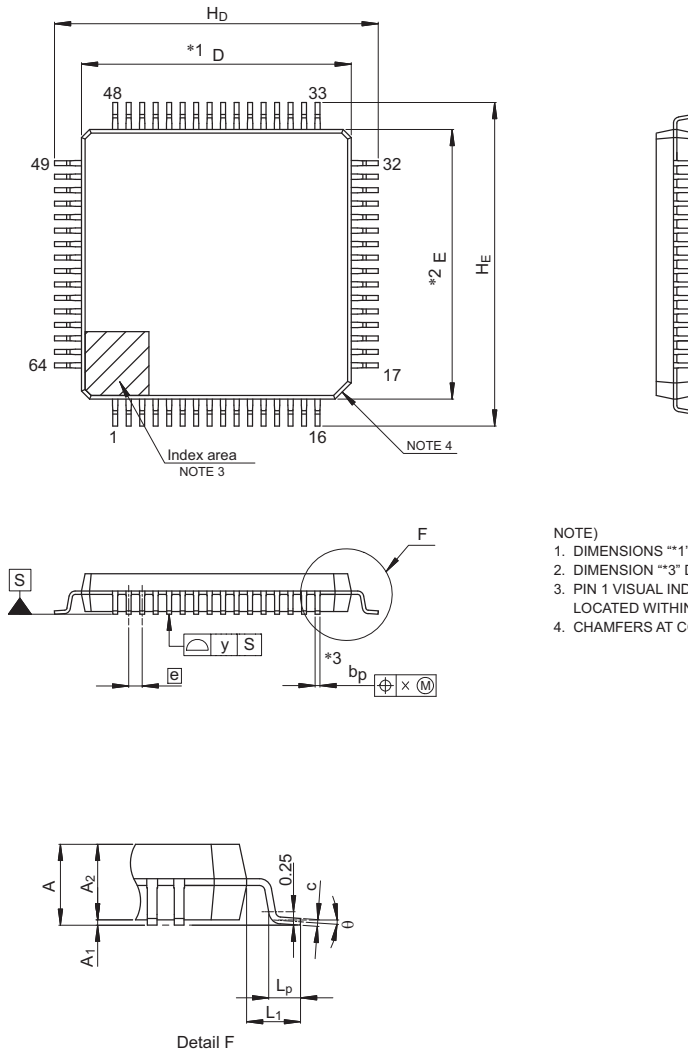

NOTE)

1. DIMENSIONS $*1$ AND $*2$ DO NOT INCLUDE MOLD FLASH.
2. DIMENSION $*3$ DOES NOT INCLUDE TRIM OFFSET.
3. PIN 1 VISUAL INDEX FEATURE MAY VARY, BUT MUST BE LOCATED WITHIN THE HATCHED AREA.
4. CHAMFERS AT CORNERS ARE OPTIONAL, SIZE MAY VARY.

| Reference Symbol | Dimensions in millimeters | | |
|------------------|---------------------------|------|------|
| | Min | Nom | Max |
| D | 9.9 | 10.0 | 10.1 |
| E | 9.9 | 10.0 | 10.1 |
| A ₂ | — | 1.4 | — |
| H _D | 11.8 | 12.0 | 12.2 |
| H _E | 11.8 | 12.0 | 12.2 |
| A | — | — | 1.7 |
| A ₁ | 0.05 | — | 0.15 |
| b _p | 0.15 | 0.20 | 0.27 |
| c | 0.09 | — | 0.20 |
| θ | 0° | 3.5° | 8° |
| e | — | 0.5 | — |
| x | — | — | 0.08 |
| y | — | — | 0.08 |
| L _p | 0.45 | 0.6 | 0.75 |
| L ₁ | — | 1.0 | — |

© 2015 Renesas Electronics Corporation. All rights reserved.

Figure 1.1 LQFP 64-pin

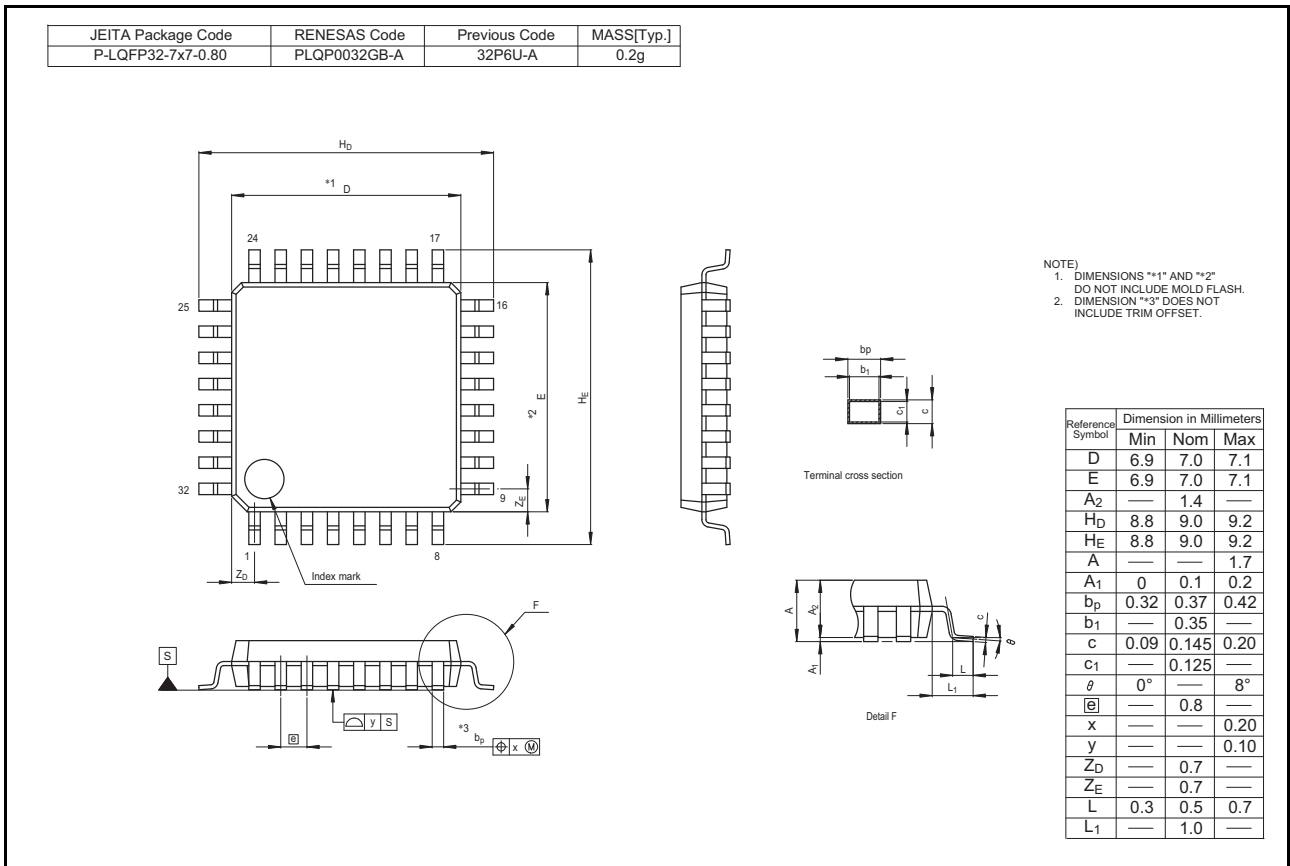

Figure 1.2 LQFP 32-pin

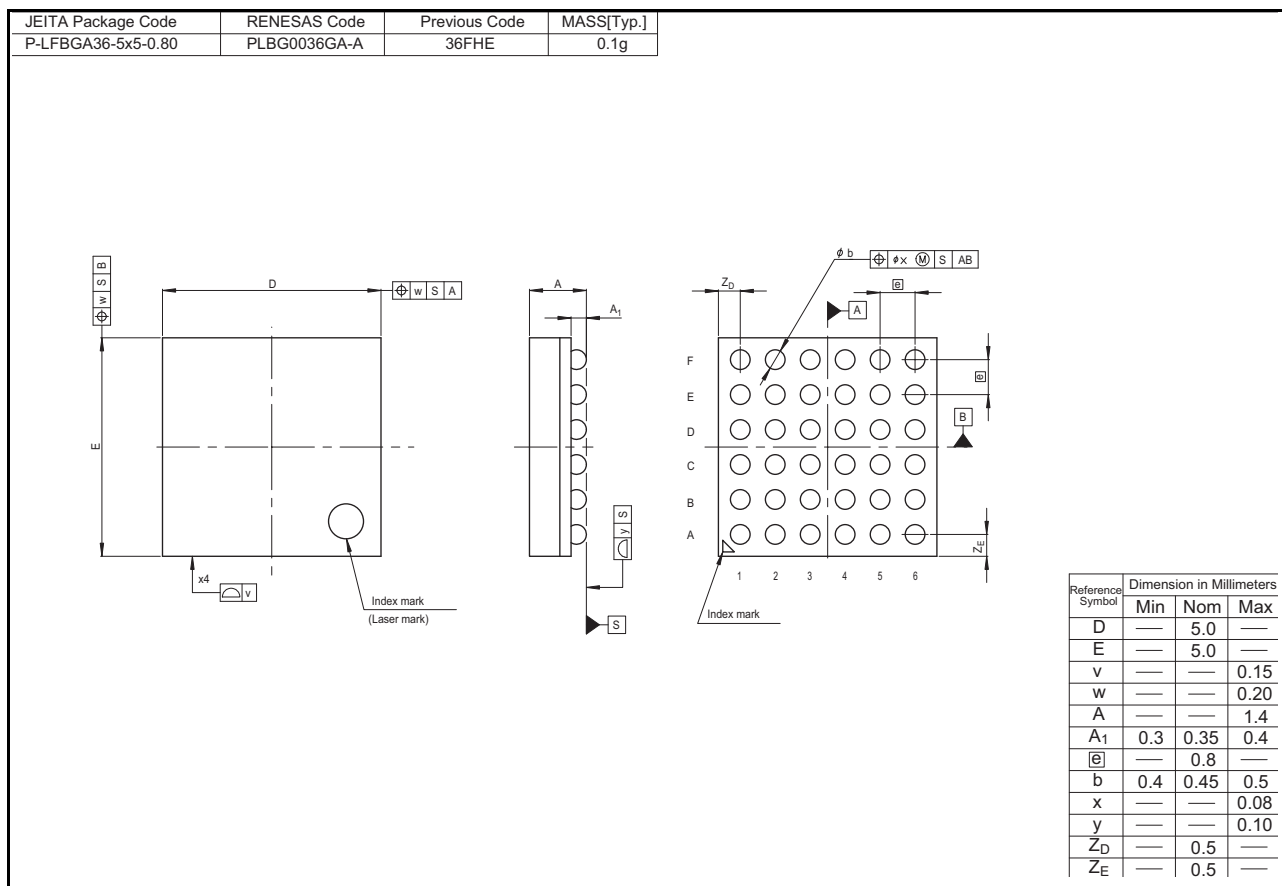
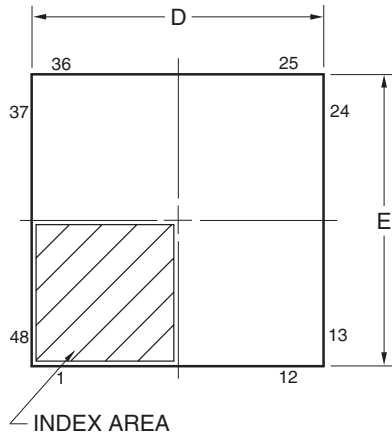
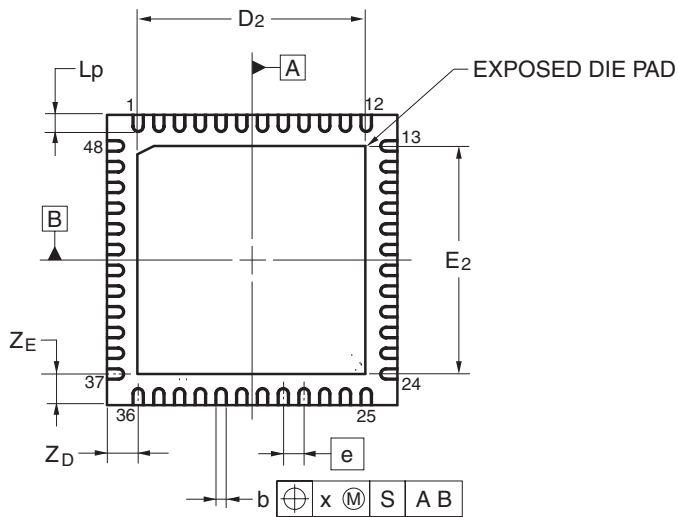
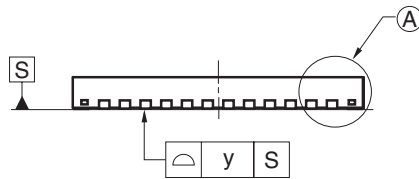
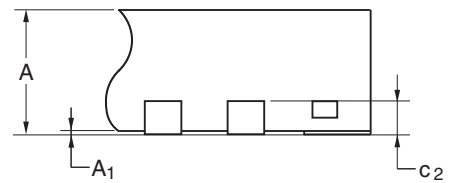

Figure 1.3 BGA 36-pin

| JEITA Package code | RENESAS code | Previous code | MASS(TYP.)[g] |
|--------------------|--------------|---------------------------|---------------|
| P-HWQFN48-7x7-0.50 | PWQN0048KB-A | 48PJN-A P48K8-50-5B4-6 | 0.13 |



DETAIL OF (A) PART



| Reference Symbol | Dimension in Millimeters | | |
|------------------|--------------------------|------|------|
| | Min | Nom | Max |
| D | 6.95 | 7.00 | 7.05 |
| E | 6.95 | 7.00 | 7.05 |
| A | — | — | 0.80 |
| A ₁ | 0.00 | — | — |
| b | 0.18 | 0.25 | 0.30 |
| \bar{e} | — | 0.50 | — |
| L _p | 0.30 | 0.40 | 0.50 |
| x | — | — | 0.05 |
| y | — | — | 0.05 |
| Z _D | — | 0.75 | — |
| Z _E | — | 0.75 | — |
| c ₂ | 0.15 | 0.20 | 0.25 |
| D ₂ | — | 5.50 | — |
| E ₂ | — | 5.50 | — |

©2013 Renesas Electronics Corporation. All rights reserved.

Figure 1.4 QFN 48-pin

| JEITA Package code | RENESAS code | Previous code | MASS(TYP.)[g] |
|--------------------|--------------|----------------|---------------|
| P-HWQFN40-6x6-0.50 | PWQN0040KC-A | P40K8-50-4B4-5 | 0.09 |

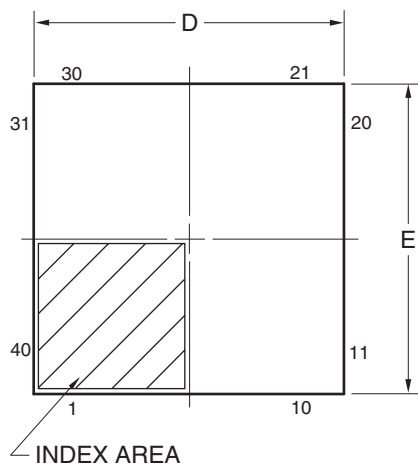

DETAIL OF (A) PART

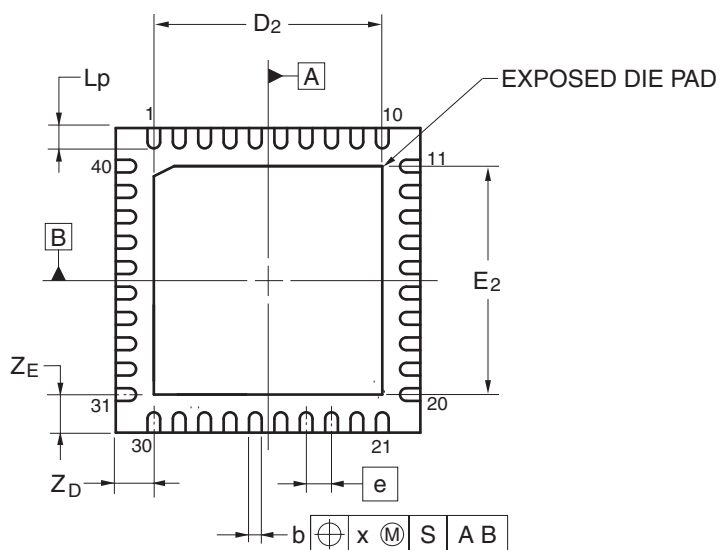
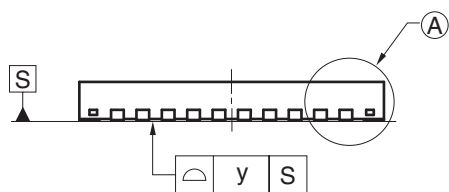
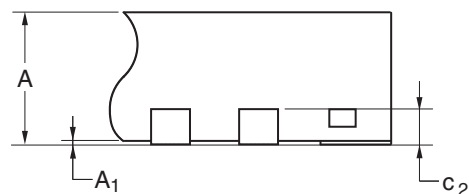

| Reference Symbol | Dimension in Millimeters | | |
|------------------|--------------------------|------|------|
| | Min | Nom | Max |
| D | 5.95 | 6.00 | 6.05 |
| E | 5.95 | 6.00 | 6.05 |
| A | — | — | 0.80 |
| A ₁ | 0.00 | — | — |
| b | 0.18 | 0.25 | 0.30 |
| e | — | 0.50 | — |
| L _p | 0.30 | 0.40 | 0.50 |
| x | — | — | 0.05 |
| y | — | — | 0.05 |
| Z _D | — | 0.75 | — |
| Z _E | — | 0.75 | — |
| c ₂ | 0.15 | 0.20 | 0.25 |
| D ₂ | — | 4.50 | — |
| E ₂ | — | 4.50 | — |

Figure 1.5 QFN 40-pin

Revision History

S1JA Microcontroller Group Datasheet

| Rev. | Date | Summary |
|------|--------------|------------------|
| 1.00 | Dec 5, 2017 | First release |
| 1.10 | Feb 28, 2018 | Updated for 1.10 |
| 1.20 | Nov 26, 2018 | Updated for 1.20 |
| 1.30 | Nov 27, 2018 | Updated for 1.30 |
| 1.40 | Aug 30, 2019 | Updated for 1.40 |

Website and Support

Visit the following vanity URLs to learn about key elements of the Synergy Platform, download components and related documentation, and get support.

| | |
|---------------------------------|--|
| Synergy Software | www.renesas.com/synergy/software |
| Synergy Software Package | www.renesas.com/synergy/ssp |
| Software add-ons | www.renesas.com/synergy/addons |
| Software glossary | www.renesas.com/synergy/softwareglossary |
| Development tools | www.renesas.com/synergy/tools |
| Synergy Hardware | www.renesas.com/synergy/hardware |
| Microcontrollers | www.renesas.com/synergy/mcus |
| MCU glossary | www.renesas.com/synergy/mcuglossary |
| Parametric search | www.renesas.com/synergy/parametric |
| Kits | www.renesas.com/synergy/kits |
| Synergy Solutions Gallery | www.renesas.com/synergy/solutionsgallery |
| Partner projects | www.renesas.com/synergy/partnerprojects |
| Application projects | www.renesas.com/synergy/applicationprojects |
| Self-service support resources: | |
| Documentation | www.renesas.com/synergy/docs |
| Knowledgebase | www.renesas.com/synergy/knowledgebase |
| Forums | www.renesas.com/synergy/forum |
| Training | www.renesas.com/synergy/training |
| Videos | www.renesas.com/synergy/videos |
| Chat and web ticket | www.renesas.com/synergy/resourcelibrary |

Proprietary Notice

All text, graphics, photographs, trademarks, logos, artwork and computer code, collectively known as content, contained in this document is owned, controlled or licensed by or to Renesas, and is protected by trade dress, copyright, patent and trademark laws, and other intellectual property rights and unfair competition laws. Except as expressly provided herein, no part of this document or content may be copied, reproduced, republished, posted, publicly displayed, encoded, translated, transmitted or distributed in any other medium for publication or distribution or for any commercial enterprise, without prior written consent from Renesas.

Arm® and Cortex® are registered trademarks of Arm Limited. CoreSight™ is a trademark of Arm Limited.

CoreMark® is a registered trademark of the Embedded Microprocessor Benchmark Consortium.

Magic Packet™ is a trademark of Advanced Micro Devices, Inc.

SuperFlash® is a registered trademark of Silicon Storage Technology, Inc. in several countries including the United States and Japan.

Other brands and names mentioned in this document may be the trademarks or registered trademarks of their respective holders.

S1JA Microcontroller Group Datasheet

Publication Date: Rev.1.40 Aug 30, 2019

Published by: Renesas Electronics Corporation

General Precautions

1. Precaution against Electrostatic Discharge (ESD)

A strong electrical field, when exposed to a CMOS device, can cause destruction of the gate oxide and ultimately degrade the device operation. Steps must be taken to stop the generation of static electricity as much as possible, and quickly dissipate it when it occurs. Environmental control must be adequate. When it is dry, a humidifier should be used. This is recommended to avoid using insulators that can easily build up static electricity. Semiconductor devices must be stored and transported in an anti-static container, static shielding bag or conductive material. All test and measurement tools including work benches and floors must be grounded. The operator must also be grounded using a wrist strap. Semiconductor devices must not be touched with bare hands. Similar precautions must be taken for printed circuit boards with mounted semiconductor devices.

2. Processing at power-on

The state of the product is undefined at the time when power is supplied. The states of internal circuits in the LSI are indeterminate and the states of register settings and pins are undefined at the time when power is supplied. In a finished product where the reset signal is applied to the external reset pin, the states of pins are not guaranteed from the time when power is supplied until the reset process is completed. In a similar way, the states of pins in a product that is reset by an on-chip power-on reset function are not guaranteed from the time when power is supplied until the power reaches the level at which resetting is specified.

3. Input of signal during power-off state

Do not input signals or an I/O pull-up power supply while the device is powered off. The current injection that results from input of such a signal or I/O pull-up power supply may cause malfunction and the abnormal current that passes in the device at this time may cause degradation of internal elements. Follow the guideline for input signal during power-off state as described in your product documentation.

4. Handling of unused pins

Handle unused pins in accordance with the directions given under handling of unused pins in the manual. The input pins of CMOS products are generally in the high-impedance state. In operation with an unused pin in the open-circuit state, extra electromagnetic noise is induced in the vicinity of the LSI, an associated shoot-through current flows internally, and malfunctions occur due to the false recognition of the pin state as an input signal become possible.

5. Clock signals

After applying a reset, only release the reset line after the operating clock signal becomes stable. When switching the clock signal during program execution, wait until the target clock signal is stabilized. When the clock signal is generated with an external resonator or from an external oscillator during a reset, ensure that the reset line is only released after full stabilization of the clock signal. Additionally, when switching to a clock signal produced with an external resonator or by an external oscillator while program execution is in progress, wait until the target clock signal is stable.

6. Voltage application waveform at input pin

Waveform distortion due to input noise or a reflected wave may cause malfunction. If the input of the CMOS device stays in the area between V_{IL} (Max.) and V_{IH} (Min.) due to noise, for example, the device may malfunction. Take care to prevent chattering noise from entering the device when the input level is fixed, and also in the transition period when the input level passes through the area between V_{IL} (Max.) and V_{IH} (Min.).

7. Prohibition of access to reserved addresses

Access to reserved addresses is prohibited. The reserved addresses are provided for possible future expansion of functions. Do not access these addresses as the correct operation of the LSI is not guaranteed.

8. Differences between products

Before changing from one product to another, for example to a product with a different part number, confirm that the change will not lead to problems. The characteristics of a microprocessing unit or microcontroller unit products in the same group but having a different part number might differ in terms of internal memory capacity, layout pattern, and other factors, which can affect the ranges of electrical characteristics, such as characteristic values, operating margins, immunity to noise, and amount of radiated noise. When changing to a product with a different part number, implement a system-evaluation test for the given product.

Notice

1. Descriptions of circuits, software and other related information in this document are provided only to illustrate the operation of semiconductor products and application examples. You are fully responsible for the incorporation or any other use of the circuits, software, and information in the design of your product or system. Renesas Electronics disclaims any and all liability for any losses and damages incurred by you or third parties arising from the use of these circuits, software, or information.
2. Renesas Electronics hereby expressly disclaims any warranties against and liability for infringement or any other claims involving patents, copyrights, or other intellectual property rights of third parties, by or arising from the use of Renesas Electronics products or technical information described in this document, including but not limited to, the product data, drawings, charts, programs, algorithms, and application examples.
3. No license, express, implied or otherwise, is granted hereby under any patents, copyrights or other intellectual property rights of Renesas Electronics or others.
4. You shall not alter, modify, copy, or reverse engineer any Renesas Electronics product, whether in whole or in part. Renesas Electronics disclaims any and all liability for any losses or damages incurred by you or third parties arising from such alteration, modification, copying or reverse engineering.
5. Renesas Electronics products are classified according to the following two quality grades: "Standard" and "High Quality". The intended applications for each Renesas Electronics product depends on the product's quality grade, as indicated below.
"Standard": Computers; office equipment; communications equipment; test and measurement equipment; audio and visual equipment; home electronic appliances; machine tools; personal electronic equipment; industrial robots; etc.
"High Quality": Transportation equipment (automobiles, trains, ships, etc.); traffic control (traffic lights); large-scale communication equipment; key financial terminal systems; safety control equipment; etc.
Unless expressly designated as a high reliability product or a product for harsh environments in a Renesas Electronics data sheet or other Renesas Electronics document, Renesas Electronics products are not intended or authorized for use in products or systems that may pose a direct threat to human life or bodily injury (artificial life support devices or systems; surgical implantations; etc.), or may cause serious property damage (space system; undersea repeaters; nuclear power control systems; aircraft control systems; key plant systems; military equipment; etc.). Renesas Electronics disclaims any and all liability for any damages or losses incurred by you or any third parties arising from the use of any Renesas Electronics product that is inconsistent with any Renesas Electronics data sheet, user's manual or other Renesas Electronics document.
6. When using Renesas Electronics products, refer to the latest product information (data sheets, user's manuals, application notes, "General Notes for Handling and Using Semiconductor Devices" in the reliability handbook, etc.), and ensure that usage conditions are within the ranges specified by Renesas Electronics with respect to maximum ratings, operating power supply voltage range, heat dissipation characteristics, installation, etc. Renesas Electronics disclaims any and all liability for any malfunctions, failure or accident arising out of the use of Renesas Electronics products outside of such specified ranges.
7. Although Renesas Electronics endeavors to improve the quality and reliability of Renesas Electronics products, semiconductor products have specific characteristics, such as the occurrence of failure at a certain rate and malfunctions under certain use conditions. Unless designated as a high reliability product or a product for harsh environments in a Renesas Electronics data sheet or other Renesas Electronics document, Renesas Electronics products are not subject to radiation resistance design. You are responsible for implementing safety measures to guard against the possibility of bodily injury, injury or damage caused by fire, and/or danger to the public in the event of a failure or malfunction of Renesas Electronics products, such as safety design for hardware and software, including but not limited to redundancy, fire control and malfunction prevention, appropriate treatment for aging degradation or any other appropriate measures. Because the evaluation of microcomputer software alone is very difficult and impractical, you are responsible for evaluating the safety of the final products or systems manufactured by you.
8. Please contact a Renesas Electronics sales office for details as to environmental matters such as the environmental compatibility of each Renesas Electronics product. You are responsible for carefully and sufficiently investigating applicable laws and regulations that regulate the inclusion or use of controlled substances, including without limitation, the EU RoHS Directive, and using Renesas Electronics products in compliance with all these applicable laws and regulations. Renesas Electronics disclaims any and all liability for damages or losses occurring as a result of your noncompliance with applicable laws and regulations.
9. Renesas Electronics products and technologies shall not be used for or incorporated into any products or systems whose manufacture, use, or sale is prohibited under any applicable domestic or foreign laws or regulations. You shall comply with any applicable export control laws and regulations promulgated and administered by the governments of any countries asserting jurisdiction over the parties or transactions.
10. It is the responsibility of the buyer or distributor of Renesas Electronics products, or any other party who distributes, disposes of, or otherwise sells or transfers the product to a third party, to notify such third party in advance of the contents and conditions set forth in this document.
11. This document shall not be reprinted, reproduced or duplicated in any form, in whole or in part, without prior written consent of Renesas Electronics.
12. Please contact a Renesas Electronics sales office if you have any questions regarding the information contained in this document or Renesas Electronics products.

(Note 1) "Renesas Electronics" as used in this document means Renesas Electronics Corporation and also includes its directly or indirectly controlled subsidiaries.

(Note 2) "Renesas Electronics product(s)" means any product developed or manufactured by or for Renesas Electronics.

(Rev.4.0-1 November 2017)



SALES OFFICES

Renesas Electronics Corporation

<http://www.renesas.com>

Refer to "<http://www.renesas.com/>" for the latest and detailed information.

Renesas Electronics Corporation

TOYOSU FORESIA, 3-2-24 Toyosu, Koto-ku, Tokyo 135-0061, Japan

Renesas Electronics America Inc.

1001 Murphy Ranch Road, Milpitas, CA 95035, U.S.A.
Tel: +1-408-432-8888, Fax: +1-408-434-5351

Renesas Electronics Canada Limited

9251 Yonge Street, Suite 8309 Richmond Hill, Ontario Canada L4C 9T3
Tel: +1-905-237-2004

Renesas Electronics Europe GmbH

Arcadiastrasse 10, 40472 Düsseldorf, Germany
Tel: +49-211-6503-0, Fax: +49-211-6503-1327

Renesas Electronics (China) Co., Ltd.

Room 101-T01, Floor 1, Building 7, Yard No. 7, 8th Street, Shangdi, Haidian District, Beijing 100085, China
Tel: +86-10-8235-1155, Fax: +86-10-8235-7679

Renesas Electronics (Shanghai) Co., Ltd.

Unit 301, Tower A, Central Towers, 555 Langao Road, Putuo District, Shanghai 200333, China
Tel: +86-21-2226-0888, Fax: +86-21-2226-0999

Renesas Electronics Hong Kong Limited

Unit 1601-1611, 16/F., Tower 2, Grand Century Place, 193 Prince Edward Road West, Mongkok, Kowloon, Hong Kong
Tel: +852-2265-6688, Fax: +852 2886-9022

Renesas Electronics Taiwan Co., Ltd.

13F, No. 363, Fu Shing North Road, Taipei 10543, Taiwan
Tel: +886-2-8175-9600, Fax: +886 2-8175-9670

Renesas Electronics Singapore Pte. Ltd.

80 Bendemeer Road, Unit #06-02 Hyflux Innovation Centre, Singapore 339949
Tel: +65-6213-0200, Fax: +65-6213-0300

Renesas Electronics Malaysia Sdn.Bhd.

Unit No 3A-1 Level 3A Tower 8 UOA Business Park, No 1 Jalan Pengerucara U1/51A, Seksyen U1, 40150 Shah Alam, Selangor, Malaysia
Tel: +60-3-5022-1288, Fax: +60-3-5022-1290

Renesas Electronics India Pvt. Ltd.

No.777C, 100 Feet Road, HAL 2nd Stage, Indiranagar, Bangalore 560 038, India
Tel: +91-80-67208700

Renesas Electronics Korea Co., Ltd.

17F, KAMCO Yangjae Tower, 262, Gangnam-daero, Gangnam-gu, Seoul, 06265 Korea
Tel: +82-2-558-3737, Fax: +82-2-558-5338

Renesas Synergy™ Platform
S1JA Microcontroller Group



Компания «Океан Электроники» предлагает заключение долгосрочных отношений при поставках импортных электронных компонентов на взаимовыгодных условиях!

Наши преимущества:

- Поставка оригинальных импортных электронных компонентов напрямую с производств Америки, Европы и Азии, а так же с крупнейших складов мира;
- Широкая линейка поставок активных и пассивных импортных электронных компонентов (более 30 млн. наименований);
- Поставка сложных, дефицитных, либо снятых с производства позиций;
- Оперативные сроки поставки под заказ (от 5 рабочих дней);
- Экспресс доставка в любую точку России;
- Помощь Конструкторского Отдела и консультации квалифицированных инженеров;
- Техническая поддержка проекта, помощь в подборе аналогов, поставка прототипов;
- Поставка электронных компонентов под контролем ВП;
- Система менеджмента качества сертифицирована по Международному стандарту ISO 9001;
- При необходимости вся продукция военного и аэрокосмического назначения проходит испытания и сертификацию в лаборатории (по согласованию с заказчиком);
- Поставка специализированных компонентов военного и аэрокосмического уровня качества (Xilinx, Altera, Analog Devices, Intersil, Interpoint, Microsemi, Actel, Aeroflex, Peregrine, VPT, Syfer, Eurofarad, Texas Instruments, MS Kennedy, Miteq, Cobham, E2V, MA-COM, Hittite, Mini-Circuits, General Dynamics и др.);

Компания «Океан Электроники» является официальным дистрибьютором и эксклюзивным представителем в России одного из крупнейших производителей разъемов военного и аэрокосмического назначения «JONHON», а так же официальным дистрибьютором и эксклюзивным представителем в России производителя высокотехнологичных и надежных решений для передачи СВЧ сигналов «FORSTAR».



JONHON

«JONHON» (основан в 1970 г.)

Разъемы специального, военного и аэрокосмического назначения:

(Применяются в военной, авиационной, аэрокосмической, морской, железнодорожной, горно- и нефтедобывающей отраслях промышленности)

«FORSTAR» (основан в 1998 г.)

ВЧ соединители, коаксиальные кабели,
кабельные сборки и микроволновые компоненты:

(Применяются в телекоммуникациях гражданского и специального назначения, в средствах связи, РЛС, а так же военной, авиационной и аэрокосмической отраслях промышленности).



Телефон: 8 (812) 309-75-97 (многоканальный)

Факс: 8 (812) 320-03-32

Электронная почта: ocean@oceanchips.ru

Web: <http://oceanchips.ru/>

Адрес: 198099, г. Санкт-Петербург, ул. Калинина, д. 2, корп. 4, лит. А